

Vacuum pumps

VGA
VGC

Pump ranges

These operating instructions concern the following oil flooded rotary vane vacuum pumps:
VGA (ultimate vacuum 20 mbar, abs.)
VGC (ultimate vacuum 2 mbar, abs.)
The vacuum capacities at atmosphere are 4, 6, 10 and 15 m³/hr operating on 50 cycles. The pumping curves showing capacity against vacuum can be seen in data sheets D 146 (VGA) and D 147 (VGC).

Description

VGA and VGC vacuum pumps are fitted as standard with a micro fine filter on the pump inlet. On the exhaust side of the pump an oil mist eliminator is fitted which has the function of re-circulating oil back into the circulation system as well as providing high efficiency separation on the pump exhaust. Both the motor and pump have a common shaft.

A standard built-in non-return valve on the inlet of the pump, seals the pump from the process when the pump is stopped. This prevents oil moving into the pumping cylinder when the pump is stationary. Excessive oil in the cylinder could cause an hydraulic lock when the pump is started and hence undue stress on the rotor blades.

The gas ballast valve (U) which is fitted as standard (at VGA optional) avoids any condensation of a small amount of water vapour inside the pump and hence emulsification of the oil. The gas ballast vapour handling capacity can be increased if required, to tolerate higher vapour loads than normal.

Optional extras: The following standard optional extras can be supplied if required: Vacuum regulating valve (ZRV), additional non-return valve (ZRK), dust inlet filter, high vacuum suction filter (ZVF), hose connection (ZSA) and motor starter (ZMS).

Suitability

These models can be used for the evacuation of a closed system or for a permanent vacuum from:

50 Hz → VGA: 20 to 500 mbar (abs.) • VGC: 2 to 200 mbar (abs.)

60 Hz → VGA: 20 to 400 mbar (abs.) • VGC: 2 to 150 mbar (abs.)

When permanently operating the pumps outside these ranges, there may be oil seepage at the exhaust port. If closed systems are evacuated from atmospheric pressure down to a suction pressure close to the ultimate vacuum, there is no problem with the oil system, providing the vacuum limit can be achieved within a 10 minute pump down time.

! The ambient and suction temperatures must be between 5 and 40°C. For temperatures outside this range please contact your supplier.

These pumps can tolerate small amounts of water vapour but water, other liquids, aggressive gases or vapours, may not be handled.

The standard versions may not be handled in explosion areas.

The back pressure on the exhaust port must not exceed + 0.1 bar.

! For all applications where an unplanned shut down of the vacuum pump could possibly cause harm to persons or installations, the corresponding safety backup system must be installed.

Handling and Setting up (pictures 1 and 2)

! Pumps that have reached operating temperature may have a surface temperature at position (Q) of more than 70°C. WARNING! Do Not Touch.

Oil filler port (H), oil sight glass (I) and oil drain plug (K) must all be easily accessible. The cooling air entries (E) and the cooling air exits (F) must have a minimum distance of 15 cm from any obstruction. The discharged cooling air must not be re-circulated. For maintenance purposes we recommend a space of 0.3 m in front of the filter (D) and oil tank cover (T).

The VGA and VGC pumps can only be operated reliably if they are installed horizontally.

! For installations that are higher than 1000 m above sea level there will be a loss in capacity. For further advice please contact your supplier.

When installed on a solid base, the pumps may be installed without fixing down. If the pumps are installed on a base plate, we would recommend fitting anti-vibration mounts. This range of vacuum pumps are almost vibration free when in operating.

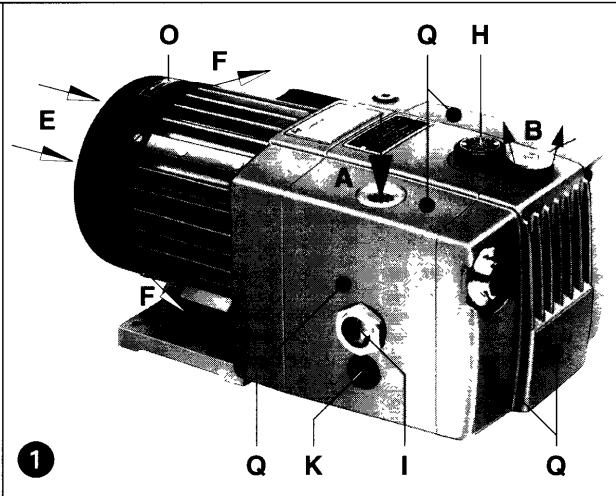

1

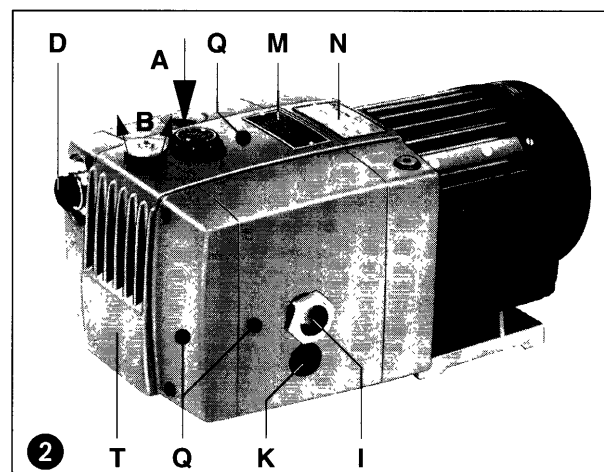

2

VGA 4

VGA 6

VGA 10

VGA 15

VGC 4

VGC 6

VGC 10

VGC 15

YE 146

1.8.96

Rietschle
Postfach 1260
D-79642 Schopfheim
Tel 07622/392-0
Fax 07622/392300
Telex 773225

Rietschle (UK) Ltd.
P W D C
Paddock Wood,
Kent TN12 6UU
Tel. 01892/835237
Fax 01892/834643

Installation (pictures 1 and 2)

! For operating and installation follow any relevant national standards that are in operation.

1 The vacuum connection at (A) The air handled can be exhausted into the atmosphere through the exhaust port (B).

! Long and/or small bore pipework should be avoided as this tends to reduce the capacity of the pump.

2. The lubricating oil (recommended brands see under servicing) can be put into the pump at the oil filler port (H) of the oil separator housing, until the oil level can be seen at the upper mark of the oil sight glass (I). After filling, make sure both oil filler ports are closed

3 The electrical data can be found on the data plate (N). The motors correspond to DIN/VDE 0530 and have IP 54 protection and insulation class F. The connection diagram can be found in the terminal box on the motor (unless a special plug connection is fitted) Check the electrical data of the motor for compatibility with your available supply (voltage, frequency, permissible current etc.).

4. Connect the motor via a motor starter. It is advisable to use thermal overload motor starters to protect the motor and wiring. All cabling used on starters should be secured with good quality cable clamps. We recommend that motor starters should be used that are fitted with a time delayed trip resulting from running beyond the amperage setting. When the unit is started cold, overamperage may occur for a short time.

! The electrical installation may only be made by a qualified electrician under the observance of EN 60204. The main switch must be planned through the operator.

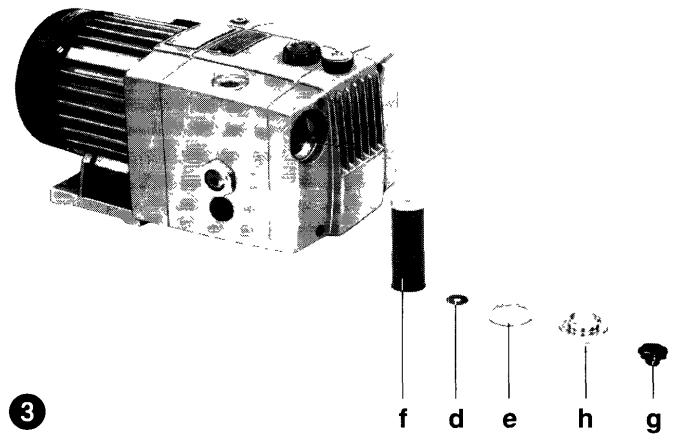

Initial Operation (picture 1)

1. Initially, switch the pump on and off for a few seconds to check the direction of rotation against the direction arrow (O).

2. Run the pump for two minutes with correct rotation. Stop pump and top up the oil using the oil filler port (H) to the correct level (see sight glass (I)). On no account open the oil filler port when the pump is operating.

3. Connect the suction pipe at (A).

4. Vacuum regulating valve (optional extra VGA):

The vacuum can be adjusted by turning the regulating valve according to the symbols, as indicated on the top of the regulating valve.

Potential risks for operating personnel

1. **Noise Emission:** The worst noise levels considering direction and intensity measured according to DIN 45635 part 3 (as per 3. GSGV) are shown in the table at the back. When working permanently in the vicinity of an operating pump, we recommend wearing ear protection to avoid any damage to hearing.

2. **Oil Aerosol in the Exhaust Stream:** Even with the high efficiency oil mist eliminator, the exhausted air could still contain extremely low amounts of oil aerosol which can occasionally be detected by smell. Permanent breathing of these aerosols may result in health problems, therefore it is extremely important to make sure that the installation area is well ventilated.

Maintenance and Servicing

! When maintaining these units and having such situations where personnel could be hurt by moving parts or by live electrical parts the pump must be isolated by totally disconnecting the electrical supply. It is imperative that the unit cannot be re-started during the maintenance operation.

Do not maintain a pump that is at its normal operating temperature as there is a danger from hot parts or hot lubricant.

1. **Air filtration (picture 3)**

! The capacity of the pump can become reduced if the air inlet filters are not maintained correctly.

The filter cartridges (f) must be cleaned regularly depending upon the amount of contamination. Cleaning can be carried out by blowing out with compressed air. Replace filters if contaminated completely.

The filter cartridges (f) can be removed from the filter housing by unscrewing the fixing knobs (g) and removing the filter cover (h) with gaskets (d/e). Cleaning or replacing the filter cartridges (f). Re-assemble in reverse order.

2. **Lubrication (pictures 1 and 2)**

Check the oil level regularly depending upon the operating hours. First oil change after 500 operating hours (see oil drain plug (K)). Further changes every 500 operating hours. The oil change times should be shortened if the application is dusty.

Only oils corresponding to DIN 51506 group VC/VCL or a synthetic oil (obtainable from Rietschle) should be used. The viscosity must correspond to ISO-VG 46 according to DIN 51519.

The recommended Rietschle Oil types are: MULTI-LUBE 46 (mineral oil); SUPER-LUBE 46 (synthetic oil) (see oil type plate (M)).

When the oil is under a high thermal load, e.g. ambient or suction temperatures over 30°C, unfavourable cooling or operating with increased speed etc., the oil change time can be extended by using the recommended synthetic oil.

! Old and used oil must be disposed of corresponding with the relevant health, safety and environmental laws.

! If the oil brand is changed, the old oil must be drained completely from the oil tank.

3. **Oil separation (picture 4)**

! Extremely blocked filter elements will result in an increased pump temperature and will cause discolouration of the lubricant.

The oil mist eliminator element may become contaminated after a long period of operation which can result in high pump temperature and motor overload. We therefore recommend to change the oil separator element (L) every 3000 operating hours. It is not possible to clean these elements.

To change separator: Unscrew the fixing knobs (g). Remove the filter cover (h). Unscrew oil tank cover (T) Exchange the elements (L). If possible re-use the o-ring (L₁) for reassembly. Re-assemble in reverse order.

Trouble Shooting

1. Motor starter cuts out vacuum pump:

- 1.1 Check that incoming voltage and frequency corresponds with the motor data plate.
- 1.2 Check the connections on the motor terminal block
- 1.3 Incorrect setting on the motor starter.
- 1.4 Motor starter trips too fast.
Solution: Use a motor starter with a time delay trip (version as per IEC 947-4)
- 1.5 The vacuum pump or the lubricating oil is too cold
- 1.6 The viscosity of lubricant is too high.
- 1.7 Oil mist eliminator element is blocked or contaminated.
- 1.8 Back pressure on the exhaust pipework is excessive.

2. Insufficient suction capacity:

- 2.1 Inlet filters are obscured.
- 2.2 Suction pipe work is too long or too small.

3. Vacuum pump does not reach ultimate vacuum:

- 3.1 Check for leaks on the suction side of the pump or on the system
- 3.2 Viscosity of lubricant incorrect.

4. Vacuum pump operates at an abnormally high temperature:

- 4.1 Ambient or suction temperature too high.
- 4.2 Cooling air flow is restricted.
- 4.3 Problem as per 1.6, 1.7 and 1.8.

5. Exhausted air contains visible oil mist:

- 5.1 Oil mist eliminator element is fitted incorrectly.
- 5.2 Incorrect oil brand is used.
- 5.3 Problem as per 1.7, 1.8, 4.1 and 4.2.

6. Unit emits abnormal noise:

Note: A knocking noise from the rotor blades is normal when starting cold, as long as it disappears within two minutes with increasing operating temperature.

- 6.1 The pump cylinder is worn.
Solution: send your complete unit off for repair to the supplier or approved Service Agent.
- 6.2 The vacuum regulating valve (if fitted) is noisy.
Solution: replace valve.
- 6.3 Blades are damaged.
- 6.4 Problem as per 1.5 and 1.6.

7. Water in lubricant i.e. Emulsification:

- 7.1 Pump pulls in water because of the application.
Solution: Fit water separators on to the vacuum side.
- 7.2 Unit handles more water vapour than the gas ballast is designed for.
Solution: Consult supplier for the provision of an increased gas ballast capability.
- 7.3 Pump operates only for a short time and does not reach normal operating temperature.
Solution: Run the pump with closed suction until the oil has been cleaned.

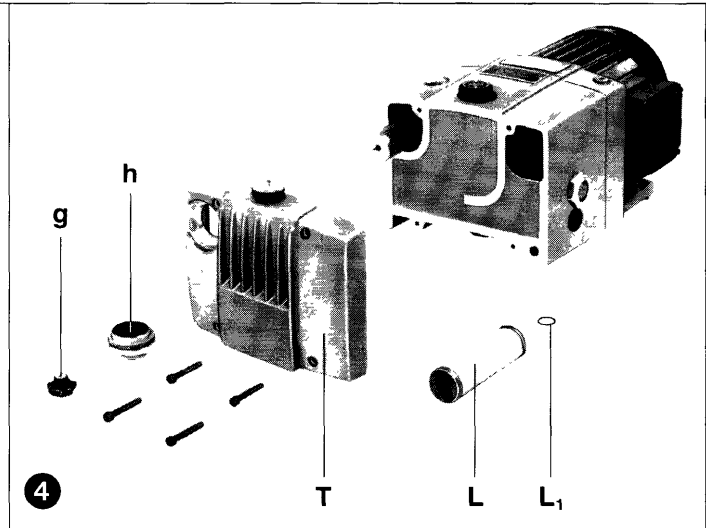

Appendix:

Repair on Site: For all repairs on site an electrician must disconnect the motor so that an accidental start of the unit cannot happen.

All engineers are recommended to consult the original manufacturer or one of the subsidiaries, agents or service agents. The address of the nearest repair workshop can be obtained from the manufacturer on application

After a repair or before re-installation follow the instructions as shown under the headings "Installation and Initial Operation".

Storage: VGA and VGC units must be stored in dry ambient conditions with normal humidity. If a pump needs to be stocked for a period longer than 3 months we would recommend using an anticorrosion oil rather than the normal lubricant.

Disposal: The fast wearing parts (as listed in the spare parts lists) should be disposed of with due regard to health and safety regulations.

VGA / VGC			4	6	10	15
Noise level (max.)	dB(A)	50 Hz	64	68	69	71
		60 Hz	64,5	68,5	69,5	71,5
Weight (max.)	kg		11,5	12,6	15,5	19,6
Length	mm	3 ~	344	344	362	404
		1 ~	356	376	402	426
Width	mm	3 ~	196	196	216	246
		1 ~	216	216	216	270
Height	mm	3 ~	180	180	184	192
		1 ~	200	200	200	192

Spare part list → VGA / VGC

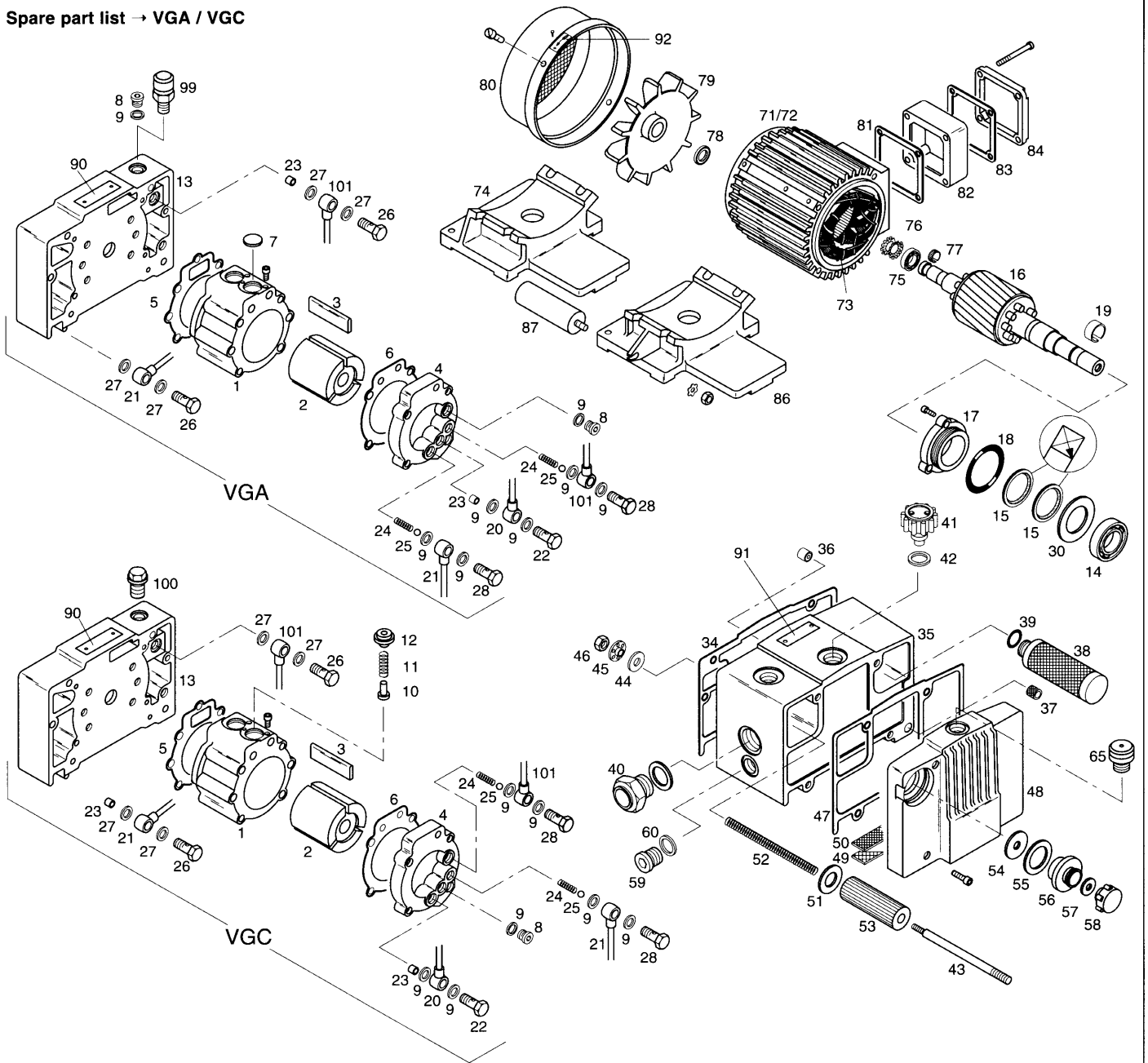

Basic unit

- 1 Housing
- 2 Rotor
- 3 V Blade
- 4 Housing cover
- 5 D Gasket
- 6 D Gasket
- 7 Cover
- 8 Lock plug M10 x 1
- 9 D Sealing ring
- 10 Valve plate
- 11 Spring
- 12 Valve guide

Pipe work

- 20 Suction
- 21 Resuction
- 22 Banjo bolt M10 x 1
- 23 Nozzle
- 24 Spring
- 25 Ball
- 26 Banjo bolt M8 x 1
- 27 D Sealing ring
- 28 Banjo bolt M10 x 1
- 101 Fresh air supply

Oil tank

- 34 D Gasket
- 35 Oil tank
- 36 Nozzle
- 37 V Suction mesh
- 38 V Oil separator element
- 39 D O-Ring
- 40 V Hex-oil sight glass
- 41 Oil filler plug
- 42 D Sealing ring
- 43 Filter bolt
- 44 D Valve disc

Connection cover

- 13 Connection cover
- 14 V Deep groove ball bearing
- 15 D Shaft seal
- 16 Motor shaft
- 17 Bearing cover
- 18 D O-Ring
- 19 V Tolerance ring
- 30 Disc

- 45 Valve plate
- 46 Hexhead screw
- 47 D Gasket
- 48 Oil tank cover
- 49 V Grill
- 50 V Mesh
- 51 D Sealing ring
- 52 Spring
- 53 V Filter cartridge
- 54 D Sealing ring
- 55 D Sealing ring
- 56 Filter cover
- 57 D Sealing ring
- 58 Filter knob
- 59 Lock plug G³/₈
- 60 D Sealing ring
- 65 Silencer

Drive

- 71 Motor housing cpl.
- 72 Motor housing
- 73 Stator
- 74 Foot (3 -)

- 75 V Deep groove ball bearing
- 76 V Spring
- 77 V Tolerance ring
- 78 D INA-sleeve
- 79 Fan
- 80 Fan cover
- 81 Gasket
- 82 Terminal box
- 83 Gasket
- 84 Terminal box cover
- 86 Foot (1 -)
- 87 Condenser (1 -)

Labels

- 90 Data plate
- 91 Oil type plate
- 92 Direction arrow

Gas ballast (at VGA optional)

- 99 Vent filter
- 100 Gas ballast screw

To order please indicate: model, serial-no., item-no., motor (kW, V, Hz)

V = Fast-wearing parts

D = Seals

Daten

Rietschle

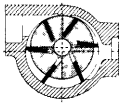

Vakuumpumpen

Vacuum Pumps

Pompes à vide

Pompe per vuoto

VGA

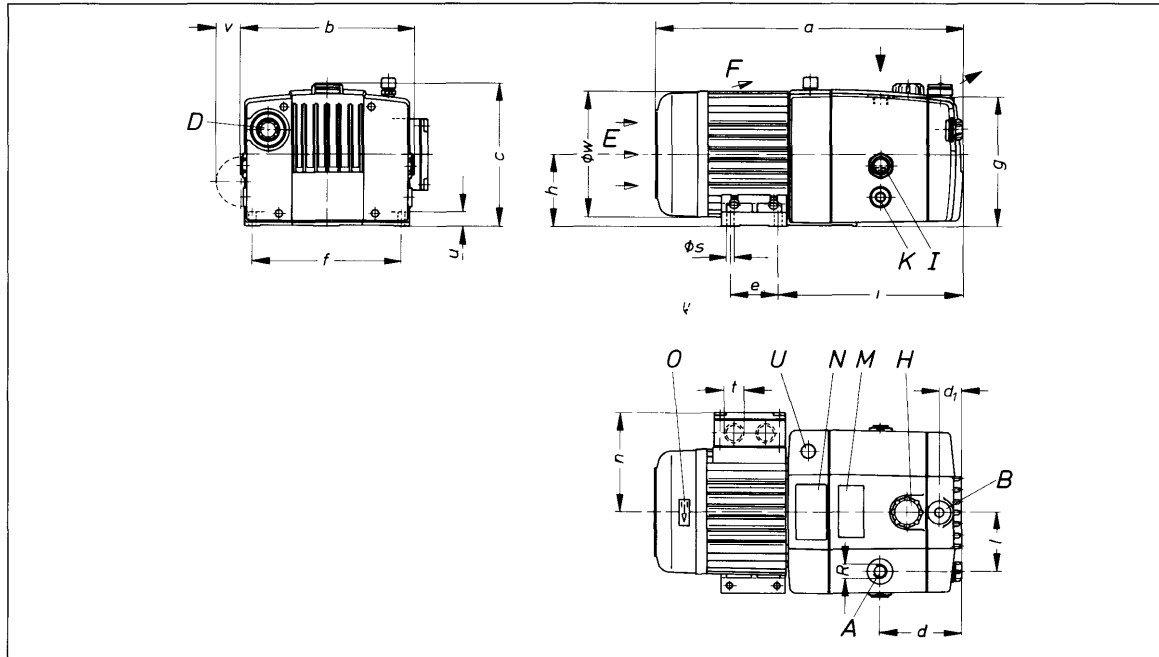

A	Vakuump-Anschluß	Vacuum connection	Raccord du vide	Attacco tubaz. aspirante
B	Abluft-Austritt	Exhaust	Refolement	Scarico aria
D	Luftfilter	Inlet filter	Filtre à air	Filtro aria
E	Kühlluft-Eintritt	Cooling air entry	Entrée air refroidissement	Entrata aria di raffredd.
F	Kühlluft-Austritt	Cooling air exit	Sortie air refroidissement	Uscita aria di raffredd
H	Öleinfüllung	Oil filler	Remplissage d'huile	Foro riempimento olio
I	Öl-Kontrolle	Oil control	Voyant d'huile	Spia livello olio
K	Öl-Ablass	Oil drain	Vidange d'huile	Scarico olio
M	Ölempfehlungsschild	Oil type plate	Etiquette huile	Targhetta oli consigliati
N	Datenschild	Data plate	Etiquette caractéristique	Targhetta dati
O	Pfeilschild	Rotation arrow	Flèche sens de rotation	Freccia senso di rotazione
U	Gasballastventil (wahlweise)	Gasballast valve (optional)	Lest d'air compact (option)	Valvola zavorra gas (opzione)

VGA		4	6	10	15
[mm]	a	3 ~ 344	344	362	404
		1 ~ 356	376	402	426
	b	204	204	204	248
	c	3 ~ 180	180	184	192
		1 ~ 200	200	200	192
	d	70	70	94	90
	d ₁	26	26	26	30
	e	90	90	90	45
	f	112	112	112	200
	g	3 ~ 170	170	174	176
		1 ~ 190	190	190	176
	h	3 ~ 95	95	100	100
		1 ~ 115	115	115	100
	i	186	186	211	230
	l	68	68	68	86
	n	3 ~ 94	94	114	122
		1 ~ 114	114	114	122
	s	7	7	7	9
	t	3 ~ Pg 11	Pg 11	Pg 13,5	Pg 13,5
		1 ~ Pg 13,5	Pg 13,5	Pg 13,5	Pg 13,5
u	12	12	12	26	
v	-	-	-	24	
Ø w	3 ~ 143	143	162	162	
	1 ~ 162	162	162	162	
R	G 3/8	G 3/8	G 3/8	G 1/2	

- VGA 4
- VGA 6
- VGA 10
- VGA 15

D 146

1.9.94

Werner Rietschle
 Maschinen- und
 Apparatebau GmbH
 Postfach 1260
 D-79642 Schopfheim
 Tel. 07622/392-0
 Fax 07622/392300
 Telex 773 225

VGA		4	6	10	15
m ³ /h	50 Hz	4,0	6,0	10,0	15,0
	60 Hz	4,8	7,2	12,0	18,0
mbar (abs.)*		20			
3 ~	50 Hz	230/400 V ± 10%			
	60 Hz	220/380 V			
1 ~	50 Hz	230 V ± 10%			
	60 Hz	220 V			
kW (50 Hz)	3 ~	0,2	0,32	0,37	0,55
	1 ~	0,2	0,32	0,37	0,55
kW (60 Hz)	3 ~	0,24	0,38	0,44	0,65
	1 ~	0,24	0,38	0,44	0,65
A (50 Hz)	3 ~	1,38/0,8	1,38/0,8	1,9/1,1	2,4/1,35
	1 ~	2,2	3,0	3,2	#
A (60 Hz)	3 ~	2,0/1,15	2,1/1,2	2,1/1,2	3,1/1,8
	1 ~	3,2	3,7	3,9	#
min ⁻¹	50 Hz	2870			
	60 Hz	3480			
dB(A)	50 Hz	63	67	68	69,5
	60 Hz	63,5	67,5	68,5	70
kg		11,5	12,6	15,5	19,6
l		0,62	0,57	0,7	1,1
ZRV		12/1	12/1	12/1	13/1
ZRK		12(03)	12(03)	12(03)	13(03)
ZVF		20(51)	20(51)	20(51)	20(52)
ZSA		12(12)	12(12)	12(12)	13(18)
ZMS (50 Hz)	3 ~	16/06	16/10	24/16	24/16
	1 ~	24	40	40	#
ZMS (60 Hz)	3 ~	24/16	24/16	24/16	40/24
	1 ~	40	40	40	#

m ³ /h	Saugvermögen	Capacity	Débit	Portata
mbar (abs.)*	Enddruck	Ultimate pressure	Pression absolue	Pressione finale
mbar (abs.)	Ansaugdruck	Suction pressure	Pression d'aspiration	Pressione di aspirazione
3 ~/1 ~	Motorausführung	Motor version	Exécution moteur	Esecuzione motore
kW	Motorleistung	Motor rating	Puissance moteur	Potenza motore
A	Stromaufnahme	Amperage nominal	Intensité absorbée	Corrente nominale
min ⁻¹	Drehzahl	Motor speed	Nombre de tours	Nr. giri
dB(A)	mittl. Schallpegel	Noise level	Niveau sonore moyen	Rumorosità media
kg	max. Gewicht	Weight	Poids max.	Peso max.
l	Ölefüllmenge	Oil capacity	Charge d'huile	Quantità olio
	Zubehör	Optional extras	Accessoires	Accessori
ZRV	Vakuum-Regulierventil	Vacuum regulation valve	Valve de réglage du vide	Valvola regolazione vuoto
ZRK	Rückschlagventil	Non return valve	Clapet anti-retour	Valvola di non ritorno
ZVF	Vakuumdichtes Ansaugfilter	Vacuum tight suction filter	Filtre d'aspiration étanche	Filtro ermetico sull'aspirazione
ZSA	Schlauchanschluß	Pipe connection	Embout	Attacco tubazione
ZMS	Motorschutzschalter	Motor starter	Disjoncteur moteur	Salva motore

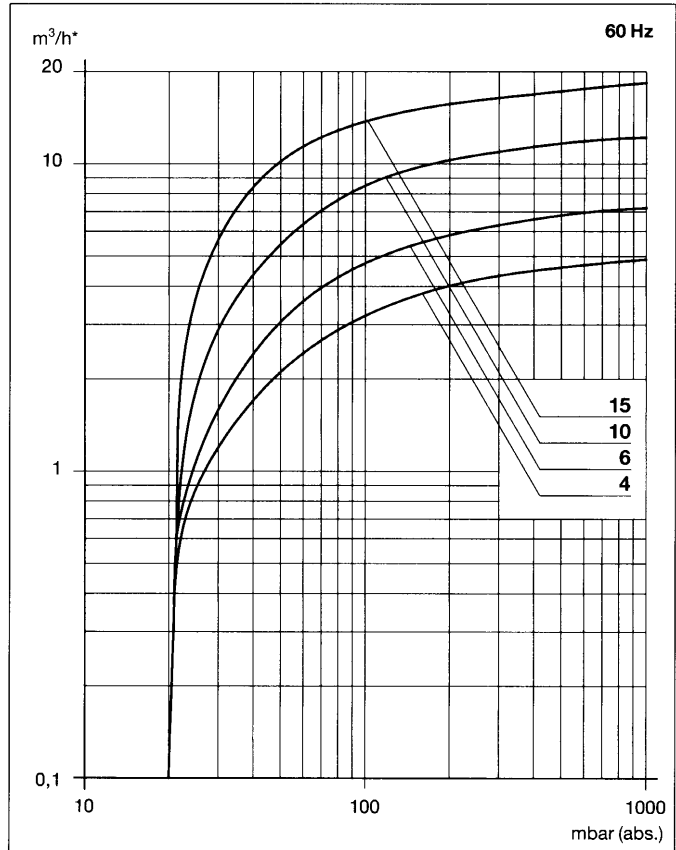
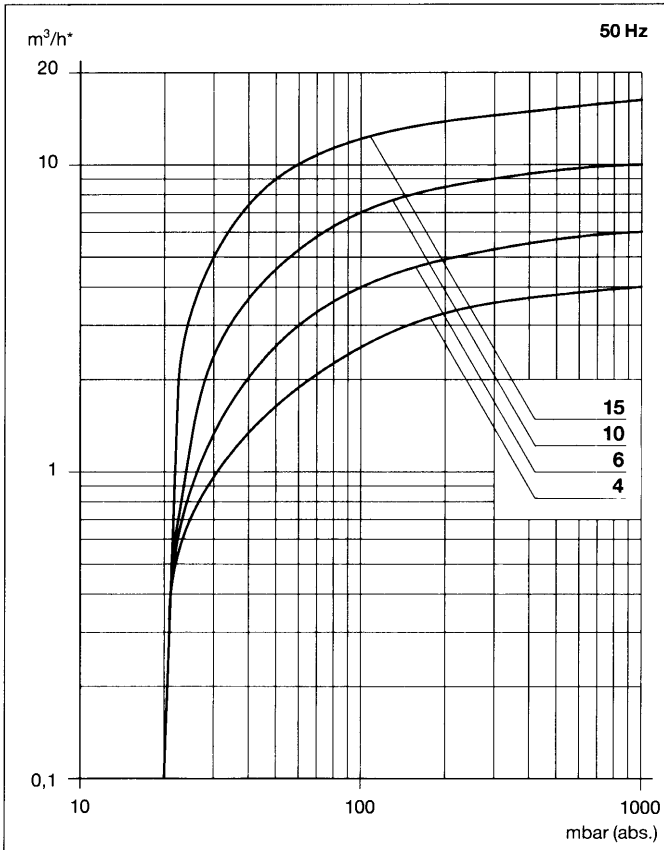

#auf Anfrage / on request / sur demande / a richiesta

*bezogen auf den Zustand im Sauganschluß / related to suction conditions at inlet connection / relatif à l'état régnant à l'aspiration / riferito alle condizioni in aspirazione
 Kennlinien und Tabellenangaben beziehen sich auf betriebswarme Vakuumpumpen / Curves and tables refer to vacuum pump at normal operating temperature / Les courbes et tableaux sont établis, pompe à température de fonctionnement / Le curve caratteristiche ed i dati riportati nelle tabelle si riferiscono alle pompe per vuoto con funzionamento a regime
 Technische Änderungen vorbehalten! / We reserve the right to alter technical information! / Sous réserve de modification technique! / Salvo modifiche tecniche!