



## US201/A/B/C

CMOS IC

### HIGH-SIDE POWER SWITCHES WITH FLAG

#### DESCRIPTION

The UTC **US201/A/B/C** series are 80mΩ high-side power switches. There's internal single low voltage N-Channel MOSFET which makes it an ideal for all USB applications. This MOSFET should be driven by a charge pump circuitry inside. Its switch on resistance is as low as 80mΩ which we know specially meets the drop voltage for USB applications.

The flag pin can output an open-drain fault flag to next controller.

There're lots internal special ways for protecting the chip's operation.

When in hot-plug events, there's large current which can create the upstream voltage droop to match the USB's voltage droop requirements and soft-start for isolating the power source.

As soon as the die temperature is higher than 130°C, the internal shutdown circuit will work.

Only when there's a normal input voltage in the V<sub>IN</sub> pin, the UVLO (under-voltage lockout, 1.3V/2.5V typ.) can make sure the chip is still in the off state.

Because of the requirement of USB power the fault current should be ensured less than 0.6A/1.1A (UTC **US201/A**, single port) and 1.3A /1.5A (UTC **US201B/C**, dual ports).

#### FEATURES

- \* 80mΩ(Typ) N-Channel MOSFET
- \* Supply Current:
  - Switch On : 25μA(Typ)
  - Switch Off : 1μA (Typ)
- \* Load Current 500mA for US201 and 1.0A for US201A/B/C
- \* Input Voltage from 2V ~ 5.5V
- \* In Off-State: Output Voltage can be Higher than Input

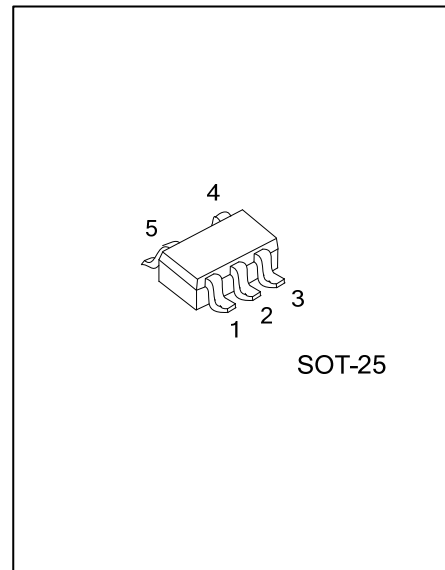

#### ORDERING INFORMATION

Ordering Number		Package	Packing
Lead Free	Halogen Free		
US201XXL-AF5-R	US201XXG-AF5-R	SOT-25	Tape Reel

<p>US201XXL-AF5-R</p> <p>(1)Packing Type (2)Package Type (3)Lead Free (4) Logic Level Enable Pin (5)Current Code</p>	<p>(1) R: Tape Reel (2) AF5: SOT-25 (3) G: Halogen Free, L: Lead Free (4) H: Active High, L: Active Low (5) Blank: 0.6A, A: 1.1A , B: 1.3A, C: 1.5A</p>
--	---

■ MARKING

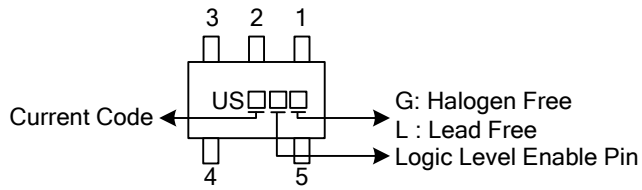

■ PIN CONFIGURATION

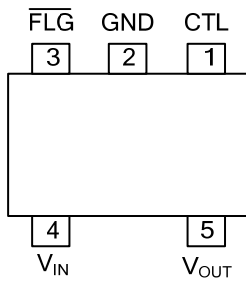

■ PIN DESCRIPTION

PIN NO	PIN NAME	DESCRIPTION
1	CTL	Enable Input pin, H: High active, L: Low active
2	GND	Ground
3	FLG	Open-drain fault flag output
4	V <sub>IN</sub>	Power input voltage
5	V <sub>OUT</sub>	Output voltage

■ BLOCK DIAGRAM

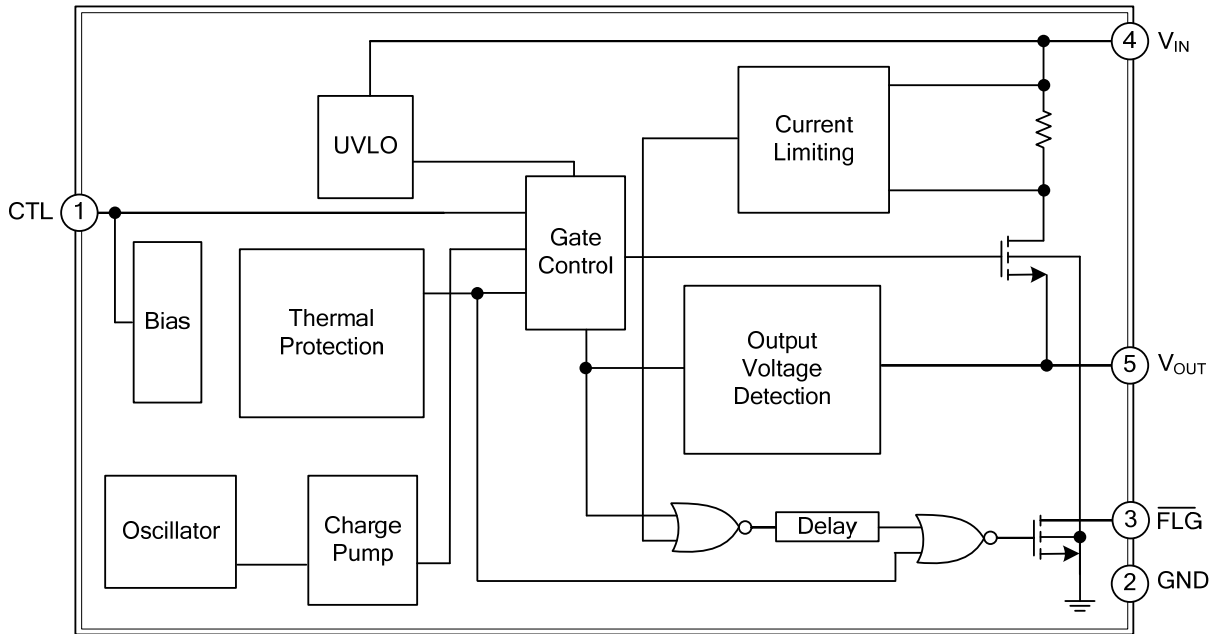

■ ABSOLUTE MAXIMUM RATING(Ta=25°C, unless otherwise specified)

PARAMETER		SYMBOL	RATINGS	UNIT
Supply Voltage		V <sub>CC</sub>	6.5	V
			+2 ~ +5.5 (Note 2)	V
Input/Output Pins	CTL	V <sub>CTL</sub>	-0.3~ +6.5	V
			0 ~ +5.5 (Note 2)	V
	FLG	V <sub>FLG</sub>	6.5	V
Power Dissipation (Ta=25°C)		P <sub>D</sub>	0.25	W
Junction Temperature		T <sub>J</sub>	150	°C
			-20 ~ +100 (Note 2)	°C
Storage Temperature		T <sub>STG</sub>	-65 ~ +150	°C

Note: 1. Absolute maximum ratings are those values beyond which the device could be permanently damaged.

Absolute maximum ratings are stress ratings only and functional device operation is not implied.

2. The device is not guaranteed to function when it's beyond its operating conditions.

■ THERMAL DATA

PARAMETER	SYMBOL	RATINGS	UNIT
Junction to Ambient	θ <sub>JA</sub>	250	°C/W

## ■ ELECTRICAL CHARACTERISTICS

PARAMETER	SYMBOL	TEST CONDITIONS	MIN	TYP	MAX	UNIT	
<b>ENABLE INPUT</b>							
CTL Threshold	Low	$V_{IL}$	$V_{IN}=2V\sim 5.5V$ , Switch OFF		0.8	V	
	High	$V_{IH}$	$V_{IN}=2V\sim 5.5V$ , Switch ON		2.0	V	
CTL Input Current	$I_{I(CTL)}$	$V_{CTL}=0V\sim 5.5V$		0.01		$\mu A$	
<b>UNDER VOLTAGE LOCK</b>							
Under-Voltage Lockout	$V_{UVLO}$	$V_{IN}$ increasing	US201/ US201A		1.3	V	
			US201B/ US201C		2.5		
Under-Voltage Hysteresis	$\Delta V_{UVLO}$	$V_{IN}$ decreasing		0.1		V	
<b>SUPPLY CURRENT</b>							
Supply Current		$I_{SW(ON)}$	Switch on, $V_{OUT}=\text{OPEN}$		25	45	$\mu A$
		$I_{SW(OFF)}$	Switch off, $V_{OUT}=\text{OPEN}$		0.1	1	$\mu A$
Output Leakage Current	$I_{O(LEAK)}$	$V_{CTL}=0V$ , $R_{LOAD}=0\Omega$		0.5	10	$\mu A$	
<b>CURRENT LIMIT</b>							
Current Limit	$I_{LIMIT}$		US201	0.6	0.8	1.1	A
			US201A	1.1	1.5	1.9	A
			US201B	1.3	1.7	2.1	A
			US201C	1.5	2.0	2.4	A
Short Circuit Fold-Back Current	$I_{SC(FB)}$	$V_{OUT}=0V$ , measured prior to thermal shutdown	US201		0.8		A
			US201A		1.0		A
			US201B		1.0		A
			US201C		1.3		A
<b>POWER SWITCH</b>							
Switch ON Resistance	$R_{DS(ON)}$	$I_{OUT}=500mA$	US201		80	110	$m\Omega$
		$I_{OUT}=1.0A$	US201A/B/C		80	110	$m\Omega$
Output Turn-ON Rise Time	$t_{ON(RISE)}$	10% ~ 90% of $V_{OUT}$ rising		400		$\mu s$	
<b>OVER CURRENT FLAG</b>							
FLAG OFF Current	$I_{FLG(OFF)}$	$V_{FLG}=5V$		0.01	1	$\mu A$	
FLAG Output Resistance	$R_{FLG}$	$I_{SINK}=1mA$		20	400	$\Omega$	
FLAG Delay Time	$t_D$	From fault condition to $\overline{FLG}$ assertion	2	10	15	ms	
<b>THERMAL SHUTDOWN</b>							
Thermal Shutdown Protection	$T_{SD}$			130		$^{\circ}C$	
Thermal Shutdown Hysteresis	$\Delta T_{SD}$			20		$^{\circ}C$	

## ■ TEST CIRCUIT

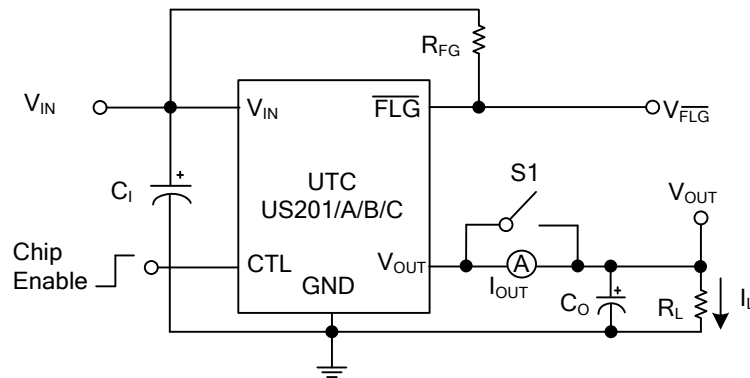

Turn-On & Off Response, Flag Response

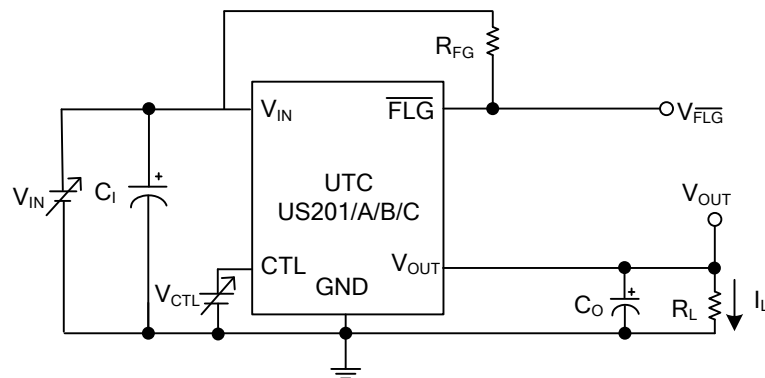

UVLO at Rising & Falling

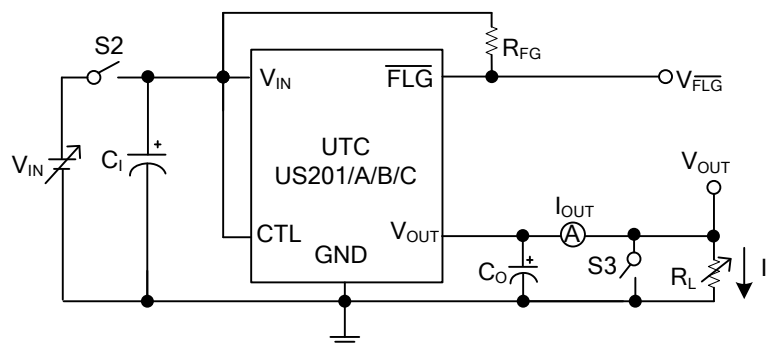

Current Limit vs. Input Voltage, Inrush Current Response, Current Limit Transient Response

## ■ TYPICAL APPLICATION CIRCUIT

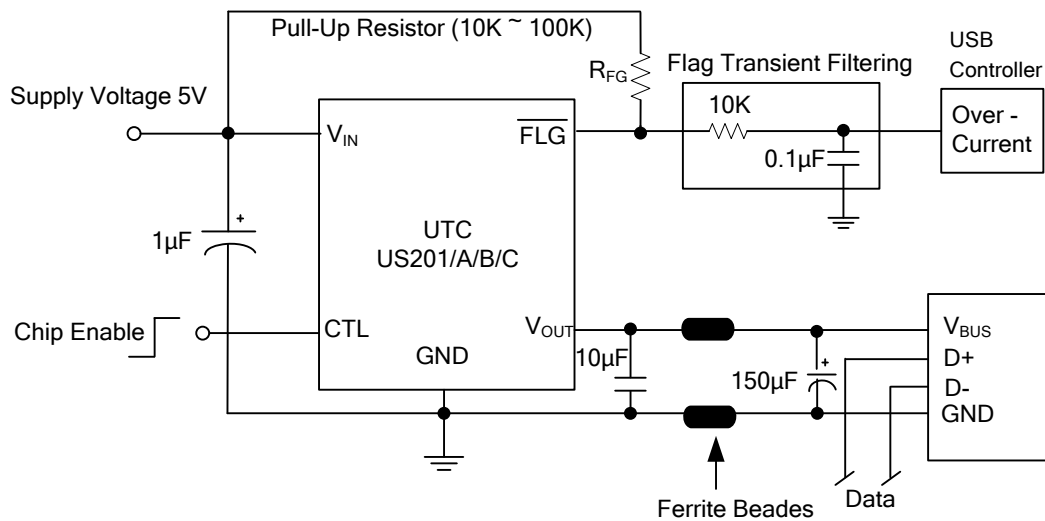

Note. A low-ESR  $150\mu\text{F}$  aluminum electrolytic or tantalum between  $V_{OUT}$  and GND is strongly recommended to meet the 330mV maximum droop requirement in the hub  $V_{BUS}$ .

UTC assumes no responsibility for equipment failures that result from using products at values that exceed, even momentarily, rated values (such as maximum ratings, operating condition ranges, or other parameters) listed in products specifications of any and all UTC products described or contained herein. UTC products are not designed for use in life support appliances, devices or systems where malfunction of these products can be reasonably expected to result in personal injury. Reproduction in whole or in part is prohibited without the prior written consent of the copyright owner. The information presented in this document does not form part of any quotation or contract, is believed to be accurate and reliable and may be changed without notice.