

B5b-436-30

DESCRIPTION

- Super bright LED Lamp
- Round type
- T1-3/4 (5mm) diameter
- Lens color: Water Clear
- With Flange
- Solder leads without stand-off

FEATURES

- Emitted color: Super Red
- High Luminous intensity
- Technology: GaAlAs
- Peak wavelength $\lambda_p = 660 \text{ nm}$
- Viewing angle: 8°

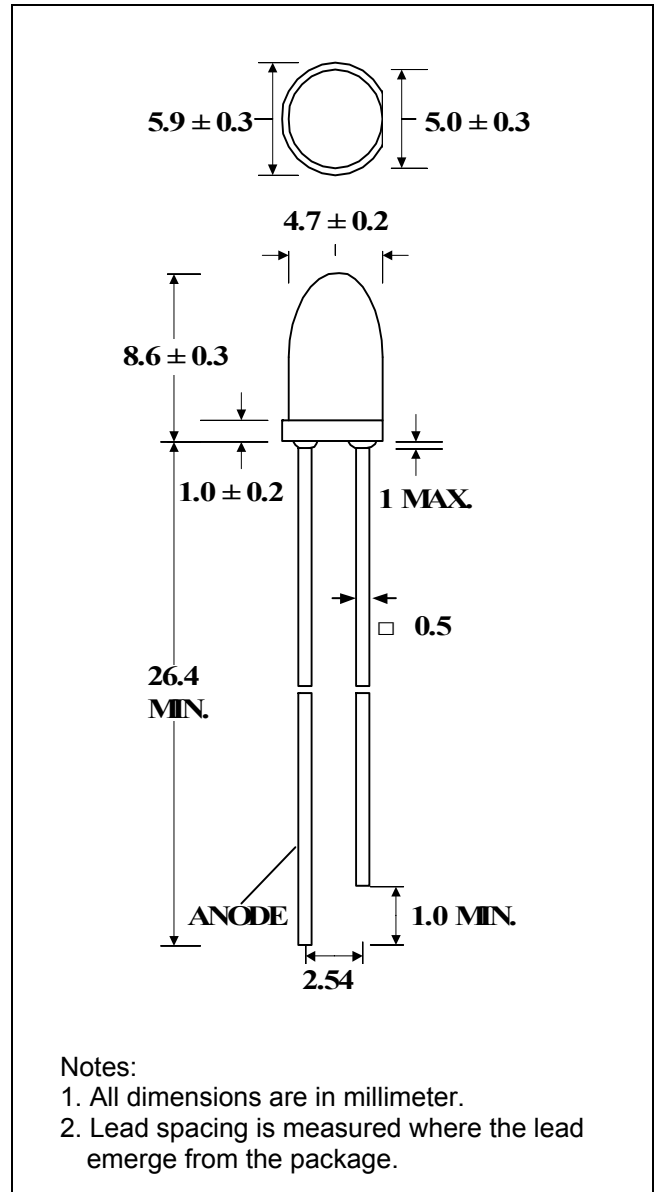

SELECTION GUIDE

Chip Material	Chip Emitted	Lens Color	Viewing Angle
GaAlAs	Super Red	Water Clear	8°

B5b-436-30

ABSOLUTE MAXIMUM RATINGS

(Ta=25 °C)

PARAMETER	SYMBOL	MAX. RATING	Unit
Power Dissipation	P_D	80	mW
Peak Forward Current (1/10 Duty Cycle @1KHz)	I_{PF}	50	mA
Continuous Forward Current	I_{AF}	30	mA
Reverse Voltage	V_R	5.0	V
Operating Temperature Range	T_{OPR}	-40~+85	°C
Storage Temperature Range	T_{STG}	-40~+85	°C

Solder temperature 1.6 mm from body for 3 seconds at 260 °C

OPTICAL-ELECTRICAL CHARACTERISTICS

PARAMETER	SYMBOL	TEST CONDITION	MIN	TYP	MAX	UNIT
Luminous Intensity	I_V	$I_F = 20\text{mA}$	2300	3500		mcd
Forward Voltage	V_F	$I_F = 20\text{mA}$		1.9	2.4	V
Reverse Current	I_R	$V_R = 5\text{V}$			10	uA
Viewing Angle	$2\theta_{1/2}$	$I_F = 20\text{mA}$		8		deg.
Peak Wavelength	λ_P	$I_F = 20\text{mA}$		660		nm
Dominant Wavelength	λ_D	$I_F = 20\text{mA}$		645		nm
Spectrum Radiation Bandwidth	$\Delta\lambda$	$I_F = 20\text{mA}$		25		nm

*Tolerance of Viewing Angle: -10 / +5 deg.

B5b-436-30

TYPICAL OPTICAL-ELECTRICAL CHARACTERISTIC CURVES

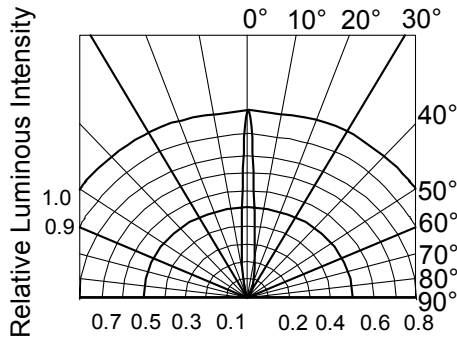

RADIATION DIAGRAM

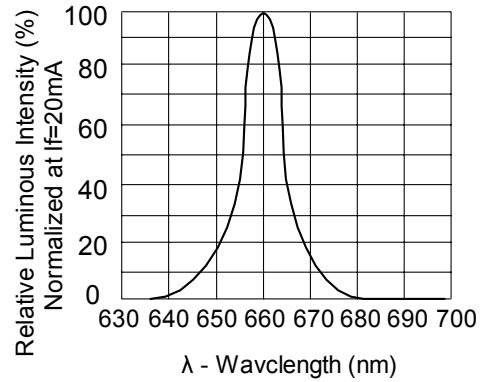

RELATIVE LUMINOUS INTENSITY Vs. WAVELENGTH

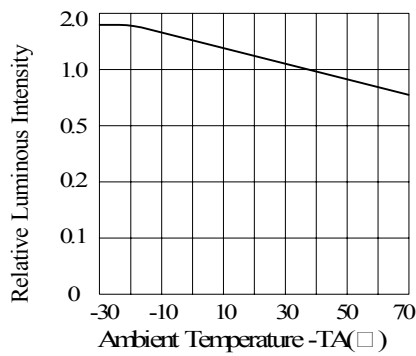

LUMINOUS INTENSITY Vs. AMBIENT TEMPERATURE

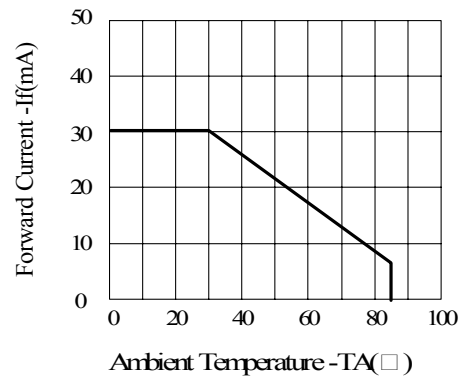

FORWARD CURRENT Vs. AMBIENT TEMPERATURE

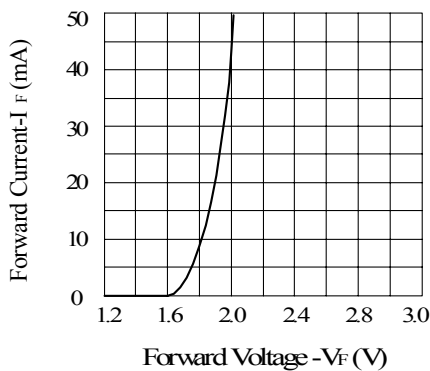

FORWARD CURRENT Vs. FORWARD VOLTAGE

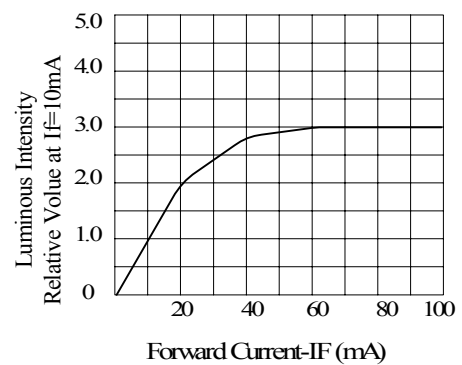

LUMINOUS INTENSITY Vs. FORWARD CURRENT