



SAA7803

One chip CD audio device

Rev. 01 — 19 April 2005

Objective data sheet

1. General description

The SAA7803 has the same features and pinning as the SAA7804 and SAA7806 devices. The SAA7803 is a multi chip module containing two additional memories, flash and SRAM, to support code development.

This IC is intended for development use only and may therefore not comply with all aspects of the Philips Semiconductors general quality specification for integrated circuits (SNW-FQ-611). This IC can therefore also not be the subject of any existing or future quality agreement. All warranties are hereby disclaimed and Philips accepts no liability or indemnity whatsoever as to the use of this IC. This IC contains multiple memories along side the audio device resulting in higher levels of emitted noise which may fail FCC certification in some application. For production the SAA7804 or SAA7806 must be used.

2. Features

2.1 Hardware features

- Channel decoder based on SAA7817 IC design
- Digital servo based on SAA7824 IC design
- 32-bit embedded ARM7 RISC microprocessor supporting both 32-bit and 16-bit Thumb® instruction sets
- Mask programmed internal program ROM for microprocessor
- Additional memory for code development
- Register structure redesigned to utilize the complete 32-bit bandwidth of the integrated microprocessor bus architecture
- Programmable clock frequency for ARM® microprocessor - allowing users to trade-off power consumption and processing power depending on requirements
- Microprocessor access to digital representations of the diode input signals from the optical pick up; the microprocessor can also generate the servo output signals RA, FO, SL and allows the possibility of additional servo algorithms or a complete servo implementation in software
- Microprocessor access to audio streams; both from the internal CD decoder and an external stereo auxiliary input (e.g. an analog source from a tuner; converted to digital via on-chip ADCs) to allow audio processing algorithms in the ARM microprocessor; e.g. bass boost and volume control
- Two general purpose analog inputs (A_IN_1 and A_IN_2) allowing the ARM microprocessor access to other external analog signals; e.g. low cost keypad; temperature sensor; via on-chip ADCs
- Two analog inputs for external audio sources (e.g. tuner) which can be accessed by the ARM for audio processing

- Slave I²S-bus mode in which the channel decoder can synchronize the CD playback speed to an input I²S-bus clock
- Integrated digital HF/mirror detector with measurement of minimum and maximum peak values, amplitude and offset
- Integrated LCD controller/driver (pins multiplexed with General Purpose Input/Outputs (GPIOs))
- Integrated CD-TEXT decoder
- 1 ×, 2 ×, 4 × or 6 × decode speed, CLV or CAV modes
- QFP100 package with 0.65 mm pin pitch
- Separate left and right channel digital silence detect available on KILL pins
- Digital silence detection available on loopback data from external source as well as internal data
- 'Filterless' pseudo-bitstream audio DAC; THD = -80 dB and S/N = 90 dB; with minimal external components
- Separate line and headphone outputs for audio DAC
- Selectable quiescent current for headphone buffers - allows users to choose between low-power consumption or lower distortion performance
- Loop back mode allowing the use of integrated DAC with external I²S-bus/EIAJ sources
- Compatible with voltage mode mechanisms
- On-chip buffering and filtering of the diode signals from the mechanism in order to optimize the signals for the decoder and servo parts
- LF (servo) signals converted to digital representations by sigma delta ADCs shared between pairs of channels to minimize DC offset between channels
- HF part summed from signals D1 to D4 and converted to digital signals by HF 6-bit ADC
- Digitally controlled selectable DC offset cancellation of quiescent mechanism voltages and dark currents; additional fine DC offset cancellation in digital domain
- Eye pattern monitor system to observe selectable points within the analog preamplifier
- Current and average jitter values available via registers
- On-chip laser power control; up to maximum currents of 120 mA
- Laser on-off control; including 'soft' start control - zero to nominal output power in 1 ms
- Monitor control and feedback circuit to maintain nominal output power throughout the life of laser
- Configured for Nsub monitor diode
- JTAG interface for device access and ARM code development (compatible with ARM multi-ICE)
- All digital input pins 5 V tolerant.

2.2 Read formats

- CD-R
- CD-RW
- CD-DA (red book)
- CD-ROM.

3. Ordering information

Table 1: Ordering information

Type number	Package		Version
	Name	Description	
SAA7803H	QFP100	plastic quad flat package; 100 leads (lead length 1.95 mm); body 14 × 20 × 2.8 mm	SOT317-2

4. Block diagram

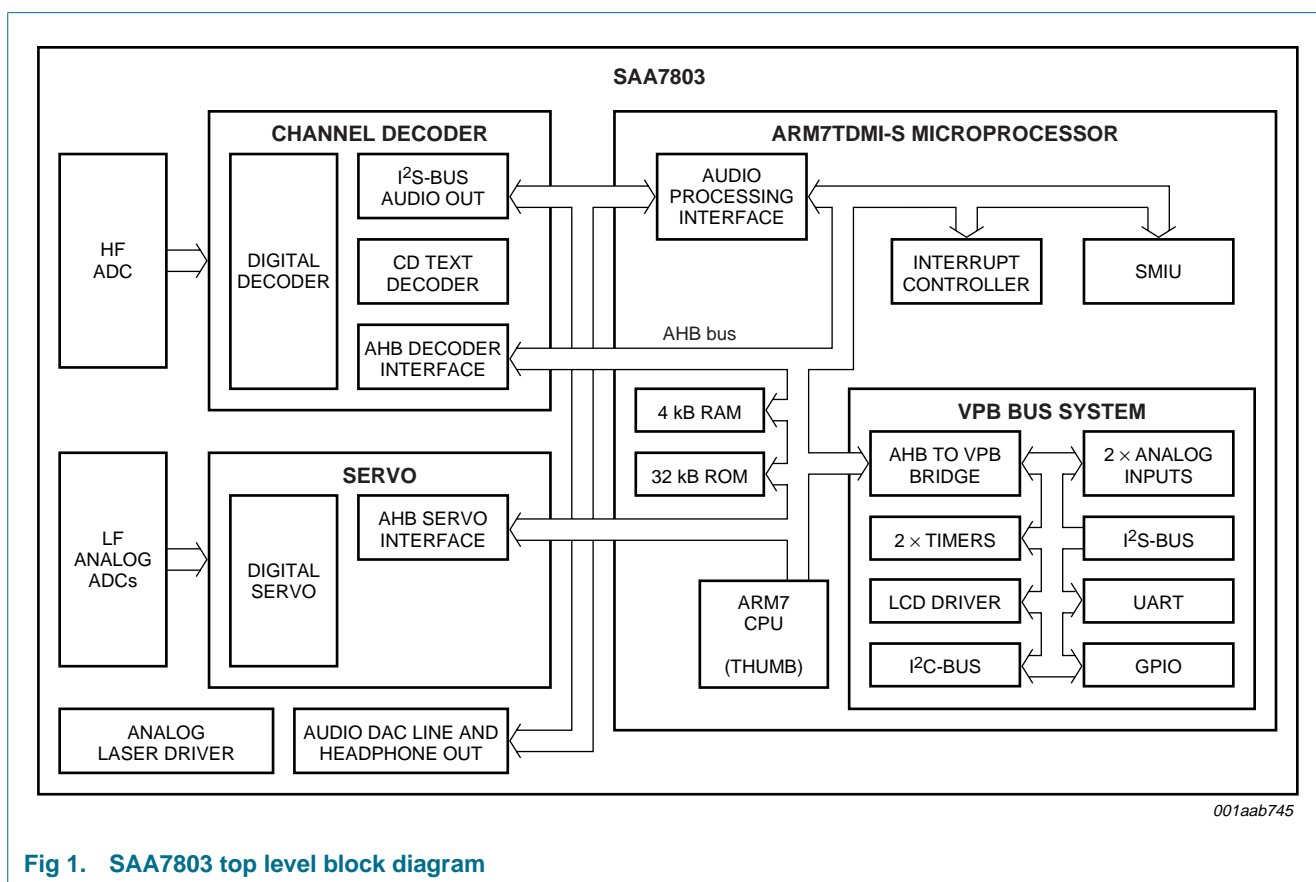

Fig 1. SAA7803 top level block diagram

5. Pinning information

5.1 Pinning

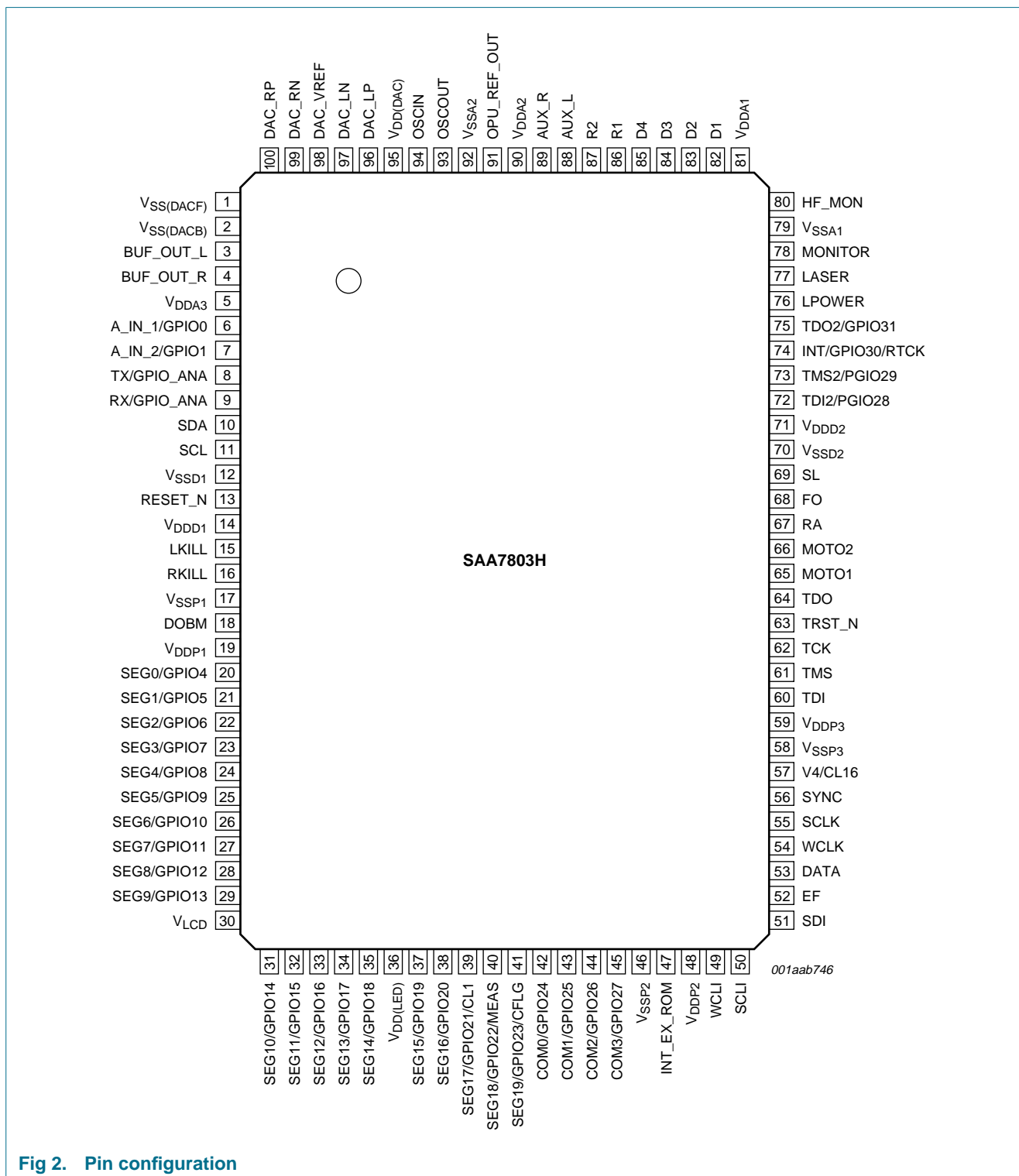

Fig 2. Pin configuration

5.2 Pin description

Table 2: Pin description

Symbol	Pin	Type	Description
V _{SS(DACF)}	1	P	audio DAC floating ground
V _{SS(DACB)}	2	P	audio DAC and buffer shared ground
BUF_OUT_L	3	AO	audio buffer left output
BUF_OUT_R	4	AO	audio buffer right output
V _{DDA3}	5	P	positive supply voltage 3 for audio buffer
A_IN_1/GPIO0	6	AIBTS	analog input 1 or general purpose I/O 0
A_IN_2/GPIO1	7	AIBTS	analog input 2 or general purpose I/O 1
TX/GPIO_ANA	8	AIBTS	UART transmit or general purpose I/O
RX/GPIO_ANA	9	AIBTS	UART receive or general purpose I/O
SDA	10	B	I ² C-bus interface data I/O line (open drain output)
SCL	11	B	I ² C-bus interface clock line
V _{SSD1}	12	P	digital core ground 1
RESET_N	13	IUH	Power-on reset (active LOW)
V _{DDD1}	14	P	digital core supply 1
LKILL	15	BTSU	kill output for left channel (configurable as open drain)
RKILL	16	BTSU	kill output for right channel (configurable as open drain)
V _{SSP1}	17	P	digital ground 1 for periphery (pads)
DOBM	18	OS	biphase mark output (no external buffer required)
V _{DDP1}	19	P	digital supply 1 for periphery (pads)
SEG0/GPIO4	20	AIBTS	LCD segment drive or general purpose I/O 4
SEG1/GPIO5	21	AIBTS	LCD segment drive or general purpose I/O 5
SEG2/GPIO6	22	AIBTS	LCD segment drive or general purpose I/O 6
SEG3/GPIO7	23	AIBTS	LCD segment drive or general purpose I/O 7
SEG4/GPIO8	24	AIBTS	LCD segment drive or general purpose I/O 8
SEG5/GPIO9	25	AIBTS	LCD segment drive or general purpose I/O 9
SEG6/GPIO10	26	AIBTS	LCD segment drive or general purpose I/O 10
SEG7/GPIO11	27	AIBTS	LCD segment drive or general purpose I/O 11
SEG8/GPIO12	28	AIBTS	LCD segment drive or general purpose I/O 12
SEG9/GPIO13	29	AIBTS	LCD segment drive or general purpose I/O 13
V _{LCD}	30	P	LCD supply voltage (5 V)
SEG10/GPIO14	31	AOBS	LCD segment drive or general purpose I/O 14
SEG11/GPIO15	32	AOBS	LCD segment drive or general purpose I/O 15
SEG12/GPIO16	33	AOBS	LCD segment drive or general purpose I/O 16
SEG13/GPIO17	34	AOBS	LCD segment drive or general purpose I/O 17
SEG14/GPIO18	35	AOBS	LCD segment drive or general purpose I/O 18
V _{DD(LED)}	36	P	LED supply voltage (3.3 V)
SEG15/GPIO19	37	AOBS	LCD segment drive or general purpose I/O 19
SEG16/GPIO20	38	AOBS	LCD segment drive or general purpose I/O 20
SEG17/GPIO21/CL1	39	AOBS	LCD segment drive or general purpose I/O 21 or clock output for sampling channel decoder telemetry outputs

Table 2: Pin description ...continued

Symbol	Pin	Type	Description
SEG18/GPIO22/MEAS	40	AOBS	LCD segment drive or general purpose I/O 22 or channel decoder telemetry output
SEG19/GPIO23/CFLG	41	AOBS	LCD segment drive or general purpose I/O 23 or channel decoder correction statistics
COM0/GPIO24	42	AIBTS	LCD back plane drive or general purpose I/O 24
COM1/GPIO25	43	AIBTS	LCD back plane drive or general purpose I/O 25
COM2/GPIO26	44	AIBTS	LCD back plane drive or general purpose I/O 26
COM3/GPIO27	45	AIBTS	LCD back plane drive or general purpose I/O 27
V _{SSP2}	46	P	digital ground 2 for periphery (pads)
INT_EX_ROM	47	ID	development ROM select (LOW = internal ROM)
V _{DDP2}	48	P	digital supply 2 for periphery (pads)
WCLI	49	I	serial word clock input (loopback)
SCLI	50	I	serial bit clock input (loopback)
SDI	51	I	serial data input (loopback)
EF	52	BTS	C1 and C2 error flag
DATA	53	OTS	serial data output
WCLK	54	BTS	word clock output
SCLK	55	BTS	serial clock output
SYNC	56	OTS	EFM frame synchronization
V4/CL16	57	BTS	versatile pin 4 or clock output 16.9344 MHz
V _{SSP3}	58	P	digital ground 3 for periphery (pads)
V _{DDP3}	59	P	digital supply 3 for periphery (pads)
TDI	60	IU	JTAG1 test data input
TMS	61	IU	JTAG1 test mode select
TCK	62	IDH	JTAG1 test clock
TRST_N	63	IU	JTAG1 asynchronous reset (active LOW)
TDO	64	OTS	JTAG1 test data output
MOTO1	65	OTS	motor output 1
MOTO2	66	OTS	motor output 2
RA	67	OTS	radial actuator
FO	68	OTS	focus actuator
SL	69	OTS	sledge actuator
V _{SSD2}	70	P	digital core ground 2
V _{DD2}	71	P	digital core supply 2
TDI2/GPIO28	72	BTSU	JTAG2 test data input or general purpose I/O 28
TMS2/GPIO29	73	BTSU	JTAG2 test mode select or general purpose I/O 29
INT/GPIO30/RTCK	74	BTS	external interrupt or general purpose I/O 30
TDO2/GPIO31	75	BTS	JTAG2 test data output or general purpose I/O 31
LPOWER	76	P	laser power supply
LASER	77	P	laser drive
MONITOR	78	AI	laser monitor diode

Table 2: Pin description ...continued

Symbol	Pin	Type	Description
V _{SSA1}	79	P	analog ground
HF_MON	80	AO	HF monitor output signal
V _{DDA1}	81	P	analog supply
D1	82	AI	diode voltage input (central diode signal input)
D2	83	AI	diode voltage input (central diode signal input)
D3	84	AI	diode voltage input (central diode signal input)
D4	85	AI	diode voltage input (central diode signal input)
R1	86	AI	diode voltage input (satellite diode signal input)
R2	87	AI	diode voltage input (satellite diode signal input)
AUX_L	88	AI	headphone buffer left input/auxiliary audio left input
AUX_R	89	AI	headphone buffer right input/auxiliary audio right input
V _{DDA2}	90	P	analog supply voltage
OPU_REF_OUT	91	AO	OPU reference voltage
V _{SSA2}	92	P	analog ground
OSCOU	93	AO	crystal or resonator output
OSCIN	94	AI	crystal or resonator input
V _{DD(DAC)}	95	P	audio DAC positive supply
DAC_LP	96	AO	audio DAC left channel differential output (positive)
DAC_LN	97	AO	audio DAC left channel differential output (negative)
DAC_VREF	98	AIO	audio DAC decoupling point (10 μ F and 100 nF in parallel to ground)
DAC_RN	99	AO	audio DAC right channel differential output (negative)
DAC_RP	100	AO	audio DAC right channel differential output (positive)

Table 3: Pin type definition [1]

Type	Definition	Type	Definition
AI	analog input	ID	digital input with pull-down
AIO	analog input/output	IDH	digital input with pull-down, hysteresis
AO	analog output	IU	digital input with pull-up
AOBS	analog output, digital bidirectional, slew rate limited	IUH	digital input with pull-up, hysteresis
B	digital bidirectional	OS	digital output
BTS	digital bidirectional, 3-stateable, slew-rate limited	OTS	digital output, 3-stateable, slew rate limited
BTSU	digital bidirectional, 3-stateable, slew-rate limited, pull-up	P	power connection
I	digital input		

- [1] All digital inputs are TTL levels.
 All digital outputs are CMOS levels.
 All digital inputs and bidirectional pins are 5 V tolerant.

6. Functional description

6.1 Analog data acquisition

The input signals from the OPU photo diodes contain information used in the servo loops and the high frequency data from which the audio samples are reconstructed. The SAA7803 contains all the necessary circuitry to process the photodiode signals directly and hence removes the need for a separate external diode signal preamplifier.

6.1.1 LF acquisition

The LF signal path acquires the photodiode voltage signals and converts them into 4 MHz Pulse Density Modulation (PDM) digital data streams. These streams are processed within the digital servo to control the focus, radial and sled loops.

The servo processing makes use of the difference calculations $D1 - D2$, $D3 - D4$ and $R1 - R2$. Ideally these differences should be zero when the quantities are equal due to the laser illumination. However in a practical system, errors reduce the accuracy of the signal processing. Two main forms of errors exist - DC offsets and relative gain mismatch between the 'difference' channels.

The DC offsets are minimized in SAA7803 by DC offset compensation circuitry which allows the DC present in the PDM streams to be measured when the laser is switched off, and then subtracted in the digital domain from the signals when the laser is on.

Relative gain mismatch is minimized by using carefully scaled circuitry in the time continuous parts of the signal path, and by time sharing circuitry in the time discrete parts. A simplified block diagram of the LF acquisition path is shown in Figure 3.

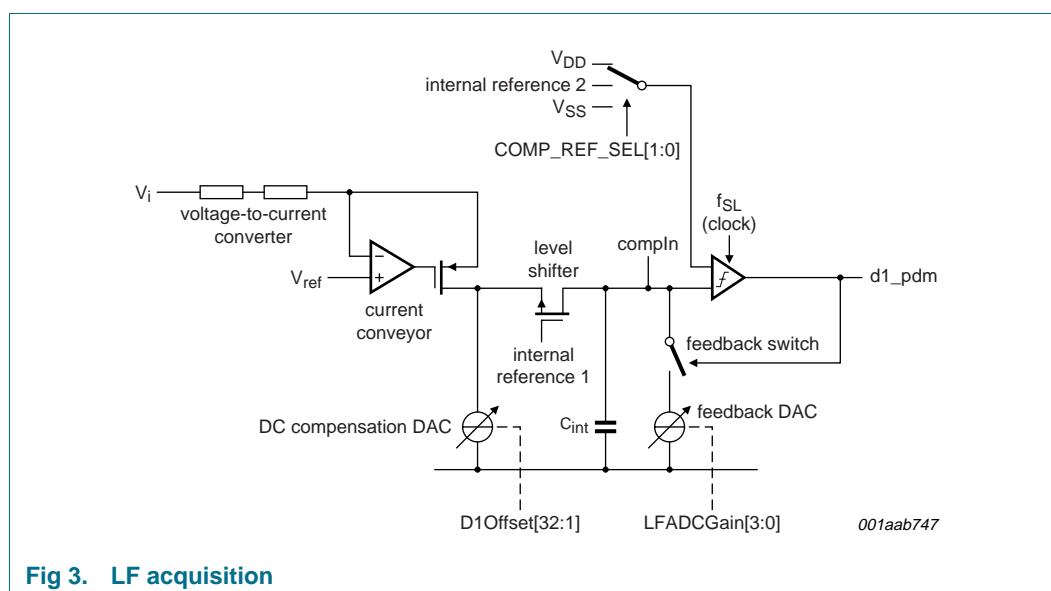

Fig 3. LF acquisition

The output of the OPU is converted to a current across the input resistor. The current conveyor provides a low input impedance and a high output impedance and sets a virtual earth at the end of the V-to-I converter to the same voltage as V_{ref} (1.6 V).

The level shifter's purpose is to act as a summing node for the DC cancellation and to produce a current that is referenced to an internal bias voltage and therefore independent of V_{ref} .

The output current charges an integration capacitor. When the voltage reaches $V_{DDA}/2$ the comparator switches and sends a feedback current that is in the opposite polarity to the input current to try to discharge the capacitor.

The register LFACTGain defines the amount of feedback current and therefore sets the gain of the ADC. The output of the ADC is a PDM waveform which is passed through a low-pass filter (in the digital domain) and the average value at the output of the filter is in proportion to the voltage between V_i and V_{ref} .

The same ADC structures are used for the auxiliary analog inputs, AUX_L and AUX_R and the general purpose analog inputs, A_IN_1 and A_IN_2. The ADCs used by the auxiliary analog inputs are multiplexed with the D1 and D2 inputs whereas the general purpose analog inputs have dedicated ADCs.

6.1.2 HF acquisition

The HF data (EFM) signal is obtained by summing the signals from the three or four central diodes of the OPU, filtering the signals and converting to a digital representation via a 6-bit RF ADC. [Figure 4](#) shows a simplified block diagram of the HF path.

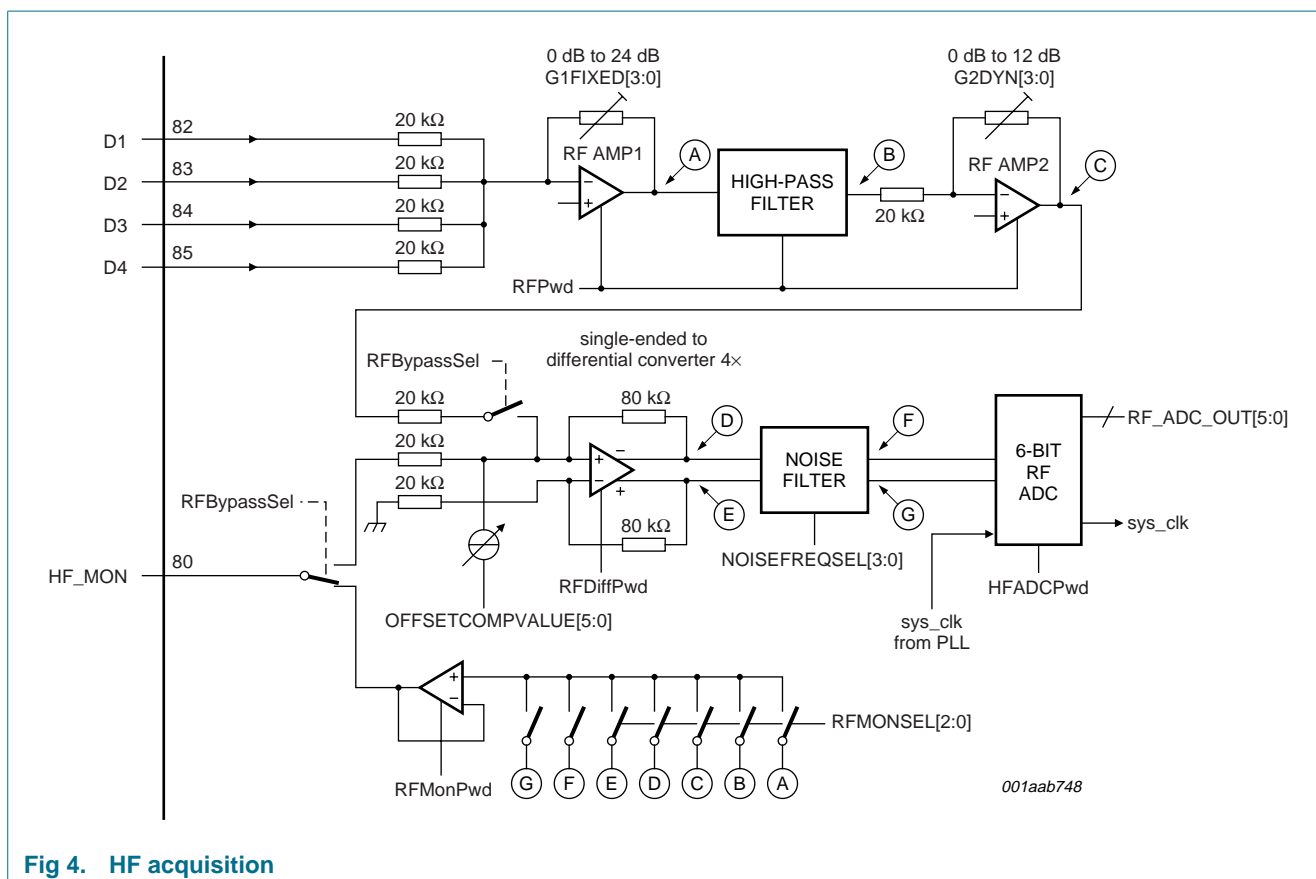

Fig 4. HF acquisition

The four diode signals D1, D2, D3 and D4 are summed in the first RF amplifier. The gain of the first amplifier is controlled by G1FIXED[3:0] (FIXED = static), register AGCGain, bits 7:4.

A second gain stage has been added to lessen the gain bandwidth requirements of a single gain stage operational amplifier and also to act with the dynamic Automatic Gain Control (AGC). The gain of this amplifier is set with G2DYN[3:0] (DYN = dynamic) register AGCGain, bits 3:0 and can be changed on the fly from the ARM microprocessor. The gain range was chosen to accommodate 12 dB of gain needed to boost the signal as the laser tracks across a finger print defect on the disc.

CD-R, CD-RW and finger prints not only reduces the AC signal amplitude compared to a perfect pressed disk, but also reduces the DC pedestal voltage. The high-pass filter will remove all DC present at the input but offsets would be added by the second and third gain stages.

A 5-bit plus sign DAC controlled by register OffsetComp, bits 5:0, OFFSETCOMPVALUE[5:0] adds a current to compensate for this offset. The amount of current will reduce in linear dB states and will track the AC gain.

To help users of the IC setup the correct gain and DC offset for each particular mechanism, an eye pattern monitor facility has been included. This consists of a high frequency buffer amplifier whose input can be selected to monitor various important nodes within the analog RF path. The monitor point is controlled by register RFControl1, bits 6:4 RFMONSEL. The output of the buffer drives pin HF_MON (pin 80).

This register also controls the roll-off frequency of the noise filter which precedes the 6-bit ADC in the RF path.

Various blocks within the analog RF path can be powered down if required, including the complete path. These power-down bits are controlled by register RFControl2, bits 5:0.

In addition, the 6-bit RF ADC can be tested stand alone in application mode or a separate external RF path IC can be connected to SAA7803 by selecting bit 1 of register 'RFBypassSel'. The input for the RF signal is then through pin HF_MON. In this mode the center diode summing circuit, RF amp1, high-pass filter and RF amp2 are all bypassed.

6.2 Analog clock generation

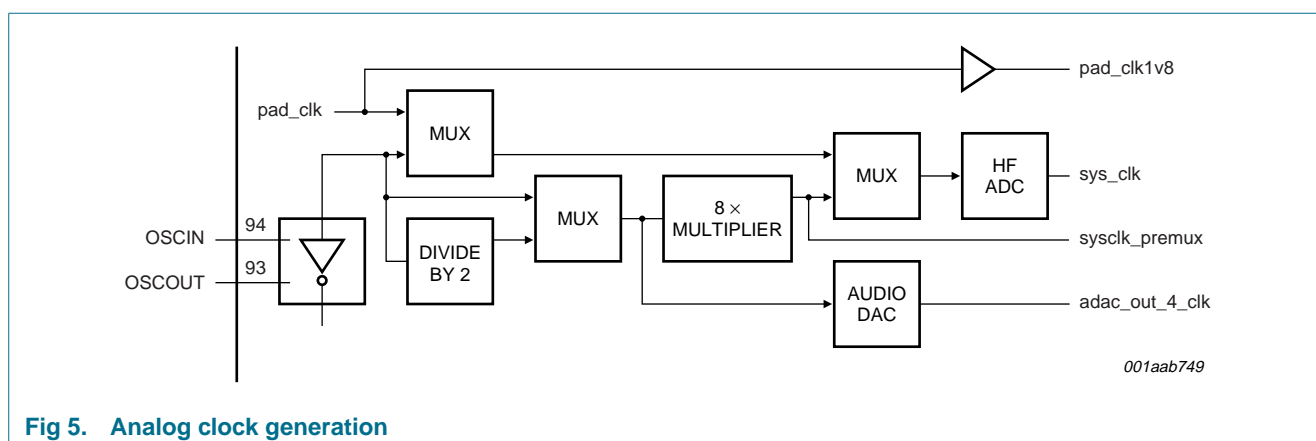

Fig 5. Analog clock generation

Sys_clk is the primary clock used by the channel decoder and ARM clock generators. This clock operates at 67 MHz with either an 8 MHz or 16 MHz crystal or resonator. The divide-by-2 is selected when a 16 MHz crystal or resonator is used.

6.3 General purpose analog inputs

The two general-purpose ADC inputs (A_IN_1, pin 6 and A_IN_2, pin 7) can be used for giving the ARM microprocessor access to external analog sources, e.g. for monitoring temperature and to provide simple resistor-ladder keypad functionality. These inputs use an additional pair of sigma delta ADCs identical to those used for the LF diode inputs.

The general purpose analog inputs have separate interrupt request lines and use address space in the servo registers for storing the converted digital values. The output of the general-purpose ADCs are low-pass filtered and can have fine offset compensation added before being passed to a decimation filter. The digital values from the decimation filter are then captured in the servo registers with 10-bit resolution per channel. See [Figure 6](#).

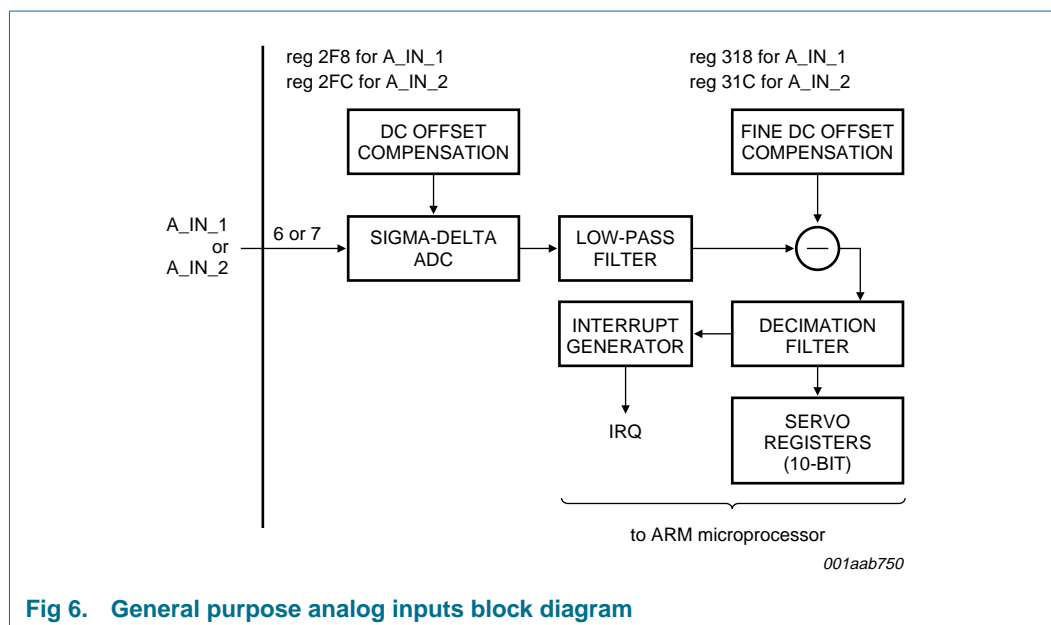

Fig 6. General purpose analog inputs block diagram

6.4 Auxiliary analog inputs

Two further analog inputs, AUX_L and AUX_R, are available with sufficient resolution for inputting external audio sources, e.g. for allowing ARM access to an external audio source for sound processing algorithms.

This allows audio processing of external audio sources via the AUX pins, whilst simultaneously using the general purpose inputs for keyboard and temperature inputs.

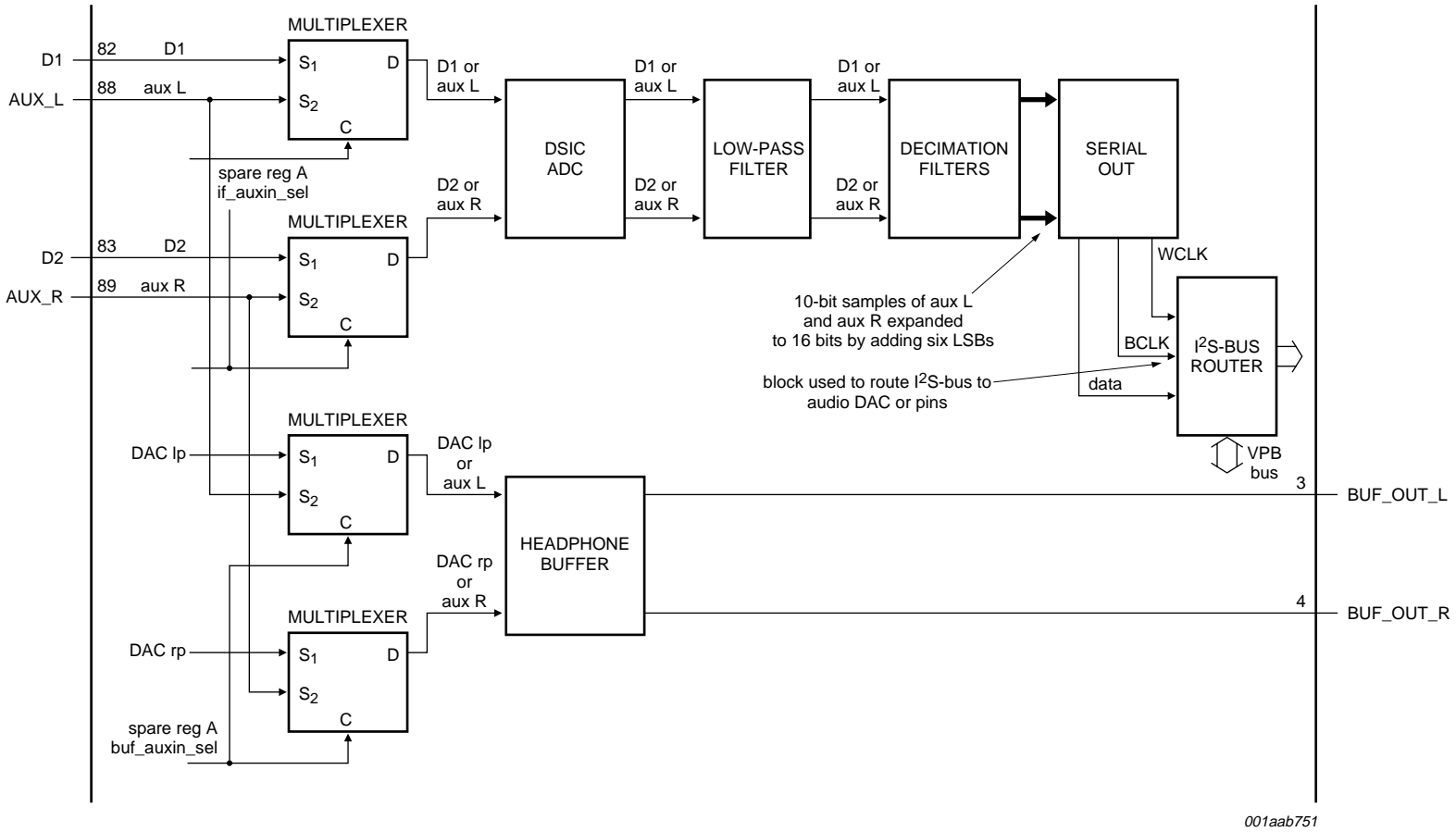

Fig 7. Auxiliary analog input

Since these two inputs share one pair of the LF sigma-delta ADCs used in the LF path (for inputs D1 and D2) a multiplexer is used to control the data source into the ADCs. For this reason, D1 and D2 cannot be used at the same time as AUX_IN_L and AUX_IN_R. A further multiplexer is used to switch the input pads from the headphone input buffer modes to auxiliary input modes. This path has a specification of SNR = 55 dB and THD < 0.3 % and can be used for tuner input processing. These performance figures are below that available when the normal CD-Audio path is used i.e. SNR > 80 dB and THD < 0.01 %. Please ensure that the signal applied to the auxiliary inputs is bandwidth limited to 20 kHz or aliasing may occur. The auxiliary inputs do have an adjustable second order anti-alias filter, but, please be aware that this may not provide enough stop band rejection in all cases.

The audio data is converted to a pulse density modulated digital stream for both input channels. This data is then low-pass filtered and decimated to produce 10-bit representations of the analog inputs.

The auxiliary input is different from the general purpose analog inputs in that the parallel data is converted to an I²S-bus format stream and then sent to the I²S-bus handler block which makes the data available to the ARM microprocessor. The I²S-bus handler contains a variable size data FIFO which means the ARM microprocessor does not have to service the audio data with as high a priority as it would if it were directly registered. See [Figure 7](#).

6.5 AHB core clock generation

Two independent clock dividers are used within SAA7803, one for CD-Slim and the other for the ARM Advanced High performance Bus (AHB) core. [Figure 8](#) gives a top level description of the SAA7803 clocking, AHB fixed clock frequencies are given. A more detailed description of the CD-Slim clocking is given in [Figure 10](#).

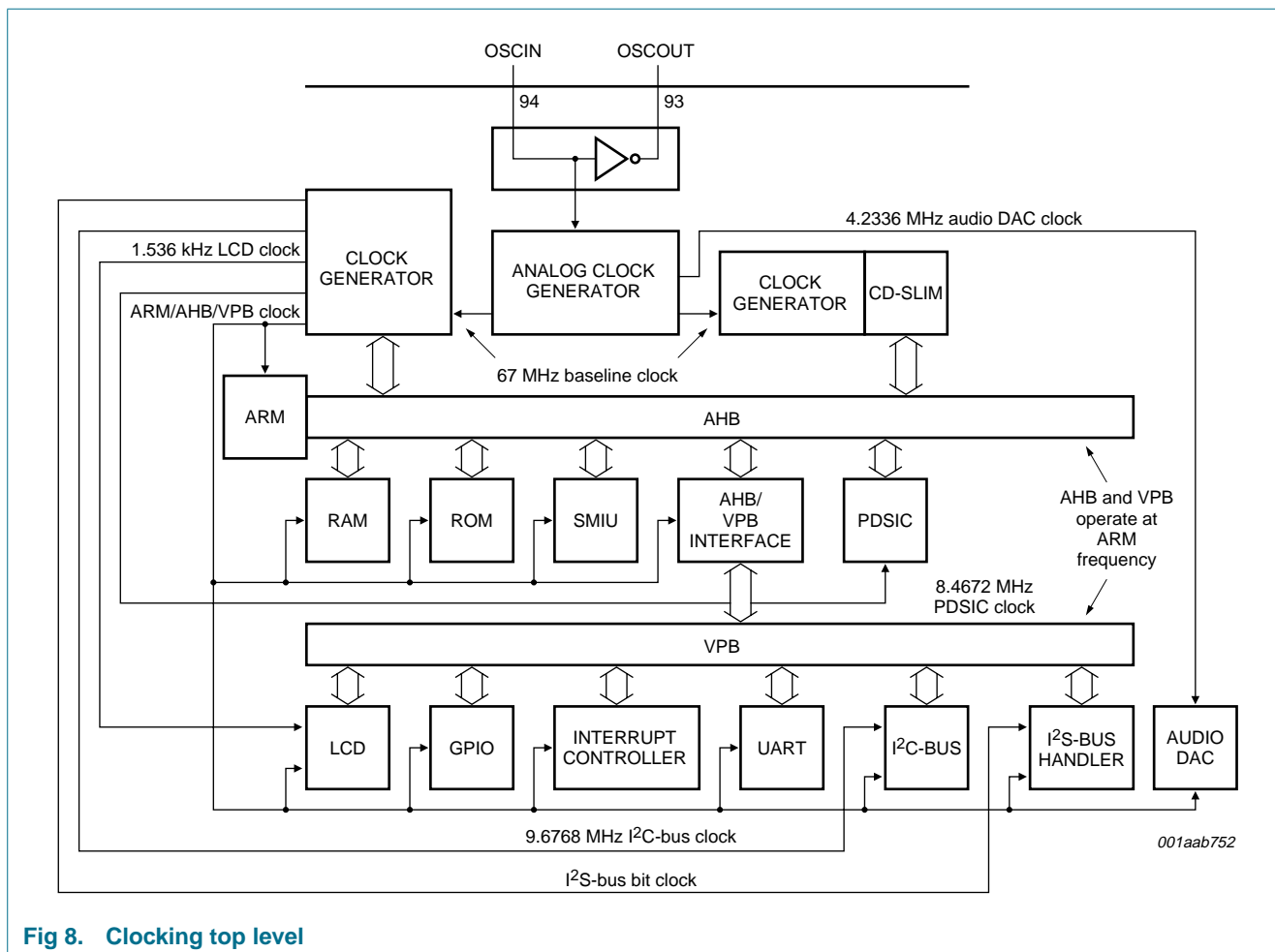

Fig 8. Clocking top level

6.6 Channel decoder

6.6.1 Features

The channel decoder in the SAA7803 is derived from the design used in the SAA7817 DVD decoder IC. The design has been optimized for CD decode functionality (i.e. EFMPlus demodulation has been removed) and has the following features:

- 1-channel interface to the on-chip 6-bit 67 MHz AD converter
- Signal conditioning logic with high-pass filter, DC offset cancellation (Analog Offset Cancellation; AOC) and AGC logic
- HF defect detection circuitry with automatic hold of AGC, AOC, High-Pass Filter (HPF), PLL and slicer on defect detection
- Digital equalizer, noise filter, PLL and slicer
- RL2PB mechanism
- EFM demodulator with sync interpolation
- CD-TEXT and subcode Q-channel extraction blocks with software-interface via registers

- Decoding, de-interleaving and Reed-Solomon error correction according to CD CIRC standards
- On-chip de-interleaving SRAM memory
- Audio processing back-end with interpolate / hold, mute, kill and silence detect logic; and de-emphasis and $4 \times$ upsample filter
- Two data-output interfaces: I²S-bus and EBU
- One serial subcode output interface
- Motor control for CLV or open loop or software controlled regulation with 1 or 2 motor pins (no onboard tacho)
- 8-bit register map; with AHB slave interface
- An interrupt output with associated interrupt, status and interrupt enable registers for full interrupt driven operation
- Debug information available via pin MEAS, pin CFLG and parallel debug-bus.

6.6.2 Block diagram

Refer to [Figure 9](#). The incoming diode signals are first added and processed in the analog front-end in order to create a proper RF (HF) signal. This analog signal is converted to digital by the ADC. This signal is then resampled from the ADC clock to the system clock domain via the int/dump block.

Offset and gain on the RF signal are regulated via the AGC/AOC loop (via the analog front-end). Remaining offset which is not removed by the analog front-end can be removed via the digital HPF. The RF signal is then sliced by the bit detector. Clock recovery is done by a full-digital PLL with noise filter, equalizer and sample rate convertor. A defect detector makes it possible to hold AGC, AOC, HPF, slicer and PLL during black / white dots. At this point in the data path, RF-samples are converted into a bitstream. The RL2 pushback will avoid RL3s in the RF being accidentally translated into RL1 or RL2 in the bitstream.

The channel bit stream is demodulated to bytes by the EFM demodulator. Q-channel subcode and CD-TEXT information is extracted via the Q-subcode and CD-TEXT decoder, available for readout through the subcpu interface. The main data stream is error-corrected by the ERCO, while the memproc takes care of the CIRC de-interleaving and buffering of data in a FIFO. At the back-end of the channel decoder, corrupted audio-samples can be interpolated and held, while a burst of errors can trigger the mute block. Detection of digital silence can be used to kill the internal / external audio DAC.

Pre-emphasis on the audio-disc can be removed via the de-emphasis filter, and the data can be $4 \times$ upsampled before sending to the audio DAC. CD-data is outputted via the I²S-bus and/or the EBU outputs. Motor control can be frequency regulated on incoming RF bit rate, with additional phase regulation on FIFO filling, or can be fully controlled via software. CLV support is guaranteed in this way, CAV support must be regulated and steered via software in open loop (no tacho available).

Debug information is available via registers, via the dedicated serial lines MEAS and CFLG and via a parallel debug bus (not available when used in an application).

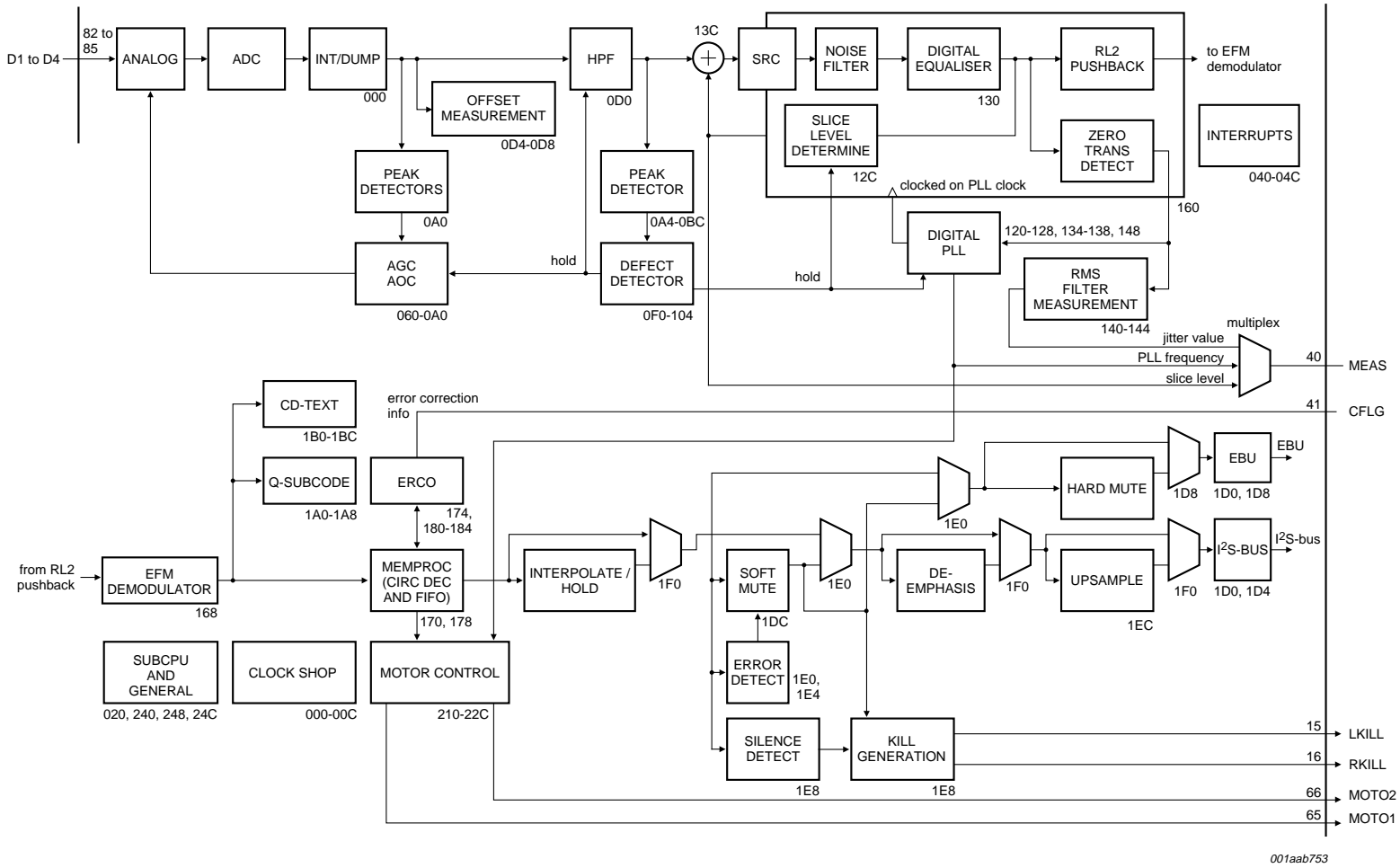

The numbers next to each functional block refer to the local address (hexadecimal) of the registers that control specific logic.

Fig 9. Channel decoder top level diagram

6.6.3 Clock control

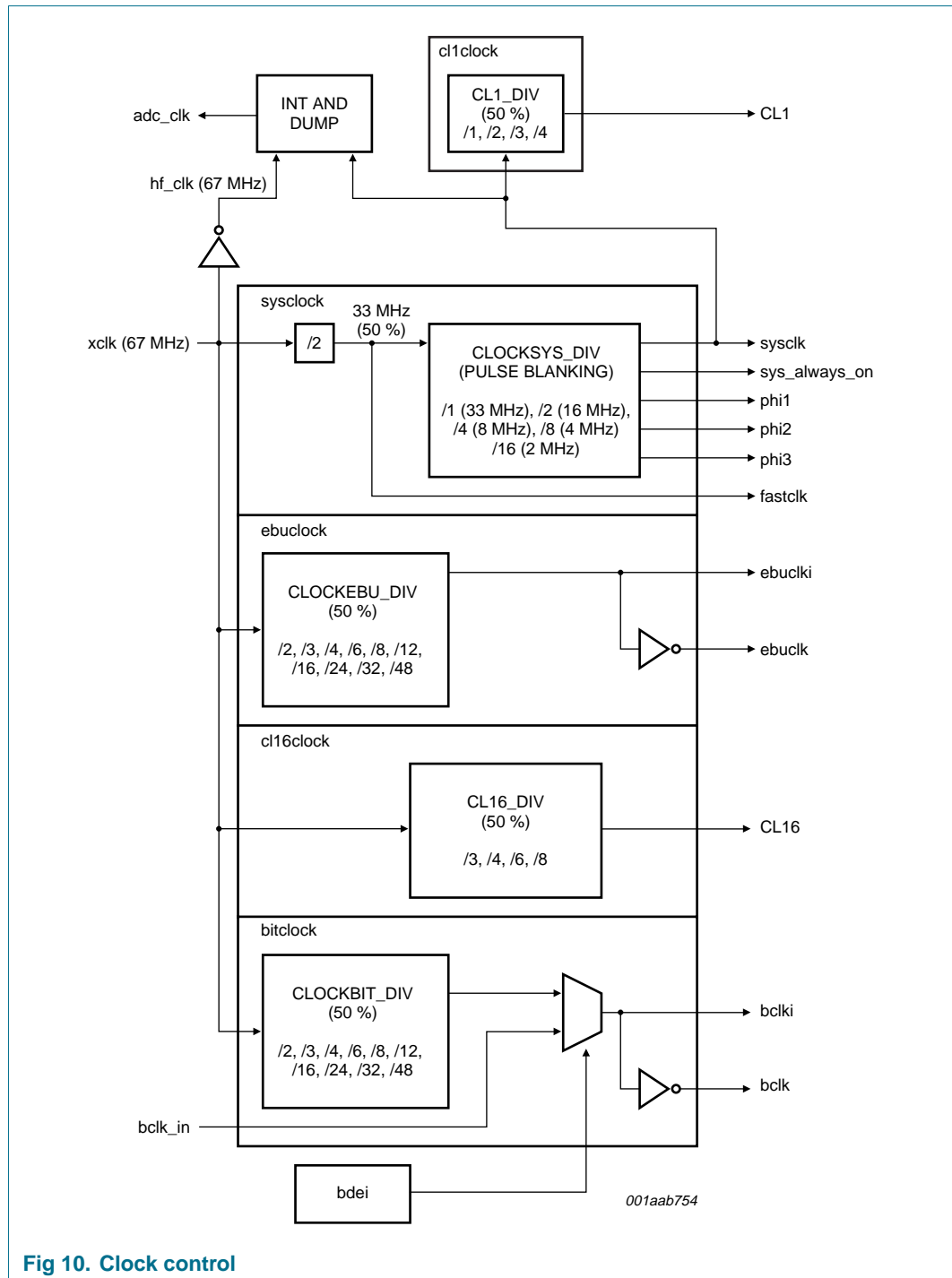

The clock control block defines the clock frequencies for four clock domains.

6.6.3.1 Signal xclk

Most internal clocks are derived from xclk. This clock is the output of the clock multiplier in the analog part and has a fixed frequency of $67.7376 \text{ MHz} = 8.4672 \text{ (crystal oscillator)} \times 8$. If a 16 MHz crystal is used, the crystal clock is divided by 2 inside the analog block. Crystal selection is done via `AnaClockPLLControl(Sel16)`.

6.6.3.2 Sysclock domain

The main part of the internal channel decoder blocks run on the sysclk or derivatives. Sysclk is derived from xclk divided by 2 (50 % duty cycle) and can be further divided down via register `SysclockConfig(SYSDIV)`. This register also provides the possibility to power-down the majority of the clocks (for sleep mode). The choice of the sysclk frequency in an application is determined by the expected input bit rate on the RF stream. The relation between this incoming bitstream frequency f_{bit} and the system clock is expressed in a $f_{\text{bit}}/f_{\text{sysclk}}$ ratio. There are 2 limiting factors:

- The HF-PLL operation range is between $0.25 \times f_{\text{bit}}/f_{\text{sysclk}}$ and $2 \times f_{\text{bit}}/f_{\text{sysclk}}$.
- The decoder and error corrector throughput rate is limited to $1.7 \times f_{\text{bit}}/f_{\text{sysclk}}$.

This brings the constraint to $0.25 < f_{\text{bit}}/f_{\text{sysclk}} < 1.7$

6.6.3.3 Bit clock domain

The I²S-bus back-end logic runs on this clock. Bclk is also output as part of the I²S-bus interface. In audio slave mode this clock needs to be programmed exactly at $44100 \times 2 \times 16/24/32 \text{ Hz}$ (depending on I²S-bus-mode), to get a $1 \times$ data rate to the audio DAC. In master mode with gated bclk, bclk must be programmed at a higher rate than the required outgoing bit rate for that disc speed, to avoid FIFO overflow in the decoder. (For instance at $N=1$, the incoming RF bit rate is 4.3218 MHz, which corresponds to an output bit rate of 1.4112 MHz. This means that bclk > 1.4112 MHz is high enough when I²S-bus-16 is chosen, while I²S-bus-32 requires at least 2.8224 MHz bclk.

The bclk division is selected via register `BitClockConfig`. Also bclk gating can be enabled via the same register.

6.6.3.4 EBU clock domain

The EBU back-end runs on this clock. The EBU (or SPDIF) interface is only enabled during audio slave mode. The ebuclk needs to be exactly $44100 \times 64 = 2.8224 \text{ MHz}$ for $1 \times$ operation. Ebuclk division is selected via register `EBUClockConfig`.

There are a few other clocks controlled by the clock control block:

- The hf_clk is fixed at 67.7376 MHz, and is used to clock in the samples from the ADC, which is clocked by the xclk with the same clock frequency
- The bclk_in is the incoming I²S-bus bit clock, which is used when I²S-bus is programmed to receive bclk rather than transmitting it (programmed via register `IISConfig`)
- The CL1 clock can be used to monitor the CFLG and MEAS debug lines; the frequency can be programmed via register `CLClockConfig`
- The CL16 clock can be used to clock an external audio DAC or audio filter IC; the frequency can be programmed via register `CLClockConfig`.

6.6.4 Decoder to ARM microprocessor interface

The decoder core is internally connected to the ARM core via the AHB interface for register access to the decoder internal configuration registers.

6.6.4.1 Programming interface

Decoder registers are programmed through the AHB interface. (A full description of the interface itself is not described in this document.)

For the application, it should be noted that the interface supports 32-bit registers, while the decoder only contains 8-bit registers. As a result, the decoder registers are treated as 32-bit registers of which the 24 MSBs are not used.

The register address map occupied by the decoder are from relative address 000h to address 374h, and can be split in 2 parts:

000h - 24Ch; the decoder's own registers, which are used to configure the channel decoder; the functionality they control is described in detail in this section

2A0h - 374h; the decoder immigrant registers, which are not used to control the decoder channel decoder; they control other parts of the SAA7803, which do not have their own AHB interface.

6.6.4.2 Interrupt strategy

The channel decoder contains 2 interrupt registers. InterruptStatus1 contains all interrupts that operate as set / reset latches (set by hardware, reset by reading from the register). InterruptStatus2 contains all interrupts that operate as feedthroughs (set by hardware, reset by hardware or by accessing other registers).

Every interrupt bit can be enabled or disabled separately by writing to the corresponding enable bit in the InterruptEnable1 and InterruptEnable2 registers. If one or more interrupt bits in the status registers are set, and at least one of them has its corresponding enable turned on, the interrupt line of the decoder to the microprocessor will go active (LOW). When an interrupt bit's corresponding enable is turned off, the interrupt status bit will behave the same as described above, the difference is that it will not trigger the interrupt line. In this mode the interrupt could still be processed if polling on the status register is used rather than real interrupt handling in the microprocessor.

6.6.5 EFM bit detection and demodulation

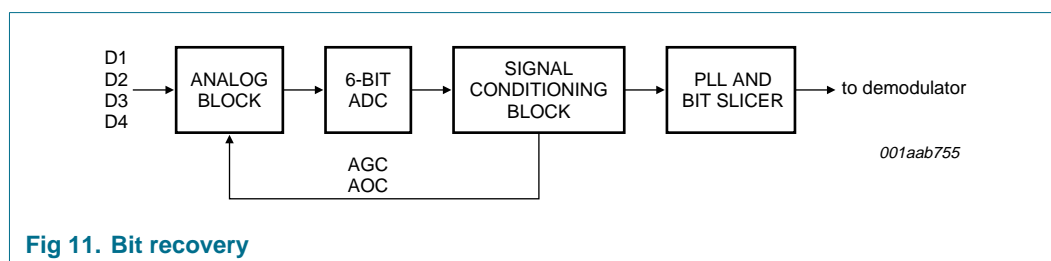

Fig 11. Bit recovery

A block diagram of the bit recovery is shown in [Figure 11](#).

The HF signal is combined from the 4 diode inputs inside the analog block. It is preprocessed (LPF, HPF, offset removal and gain adjustment) and then sampled by a 6-bit ADC.

On the sampled HF, bit recovery is done by a full digital PLL and slicer.

Before the sampled signal enters the PLL section, it is preprocessed by a signal conditioning block. This consists of an integrate and dump block, a high-pass filter and logic for gain control and offset control on the RF-signal in the analog section.

For good playability on defects, a defect detector is used to hold the PLL, slicer, AGC, offset cancellation and high-pass filter during defects.

The detected bits are then sent to the demodulator for sync extraction and EFM demodulation. For playing on damaged or out-of-spec disks, flywheels are used to make the sync extraction more robust.

6.6.5.1 Signal conditioning

This device has a number of blocks which process the incoming 6-bit HF-signal:

- Integrate and dump block to adapt the frequency of the AD converter to the system clock
- Peak detection logic for amplitude measurement
- Peak detection logic for DC offset measurement
- Digital high-pass filter with configurable cutoff frequency
- DC and gain control logic for on-board variable gain and offset control (in the analog section)
- A defect detector.

All blocks can be configured under microprocessor control.

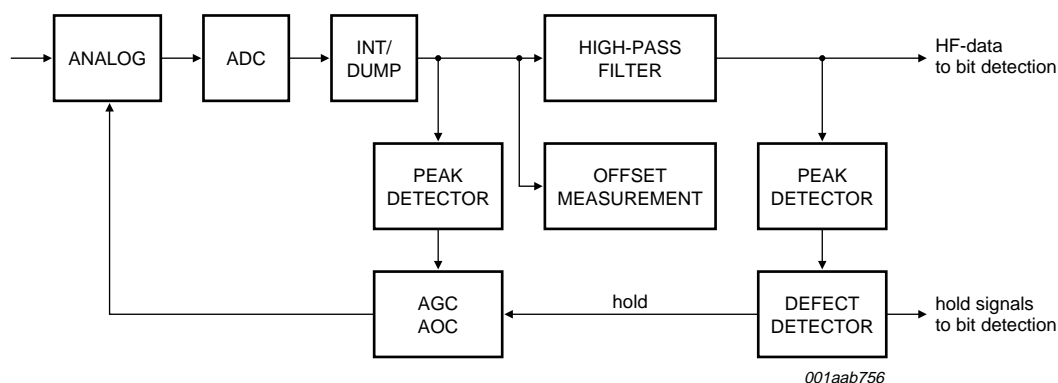

Fig 12. Signal conditioning

Integrate and dump block: The ADC delivers one sample every $xclk$ period (equal to one sample every hf_clk period). The sample rate needs to be adapted from this $xclk$ rate to the lower $sysclk$ rate. For more information on $sysclk$ speed, see [Section 6.6.3 "Clock control" on page 17](#).

The integrate and dump block converts the incoming samples at the hf_clk frequency into a stream of one sample per sysclk period. It averages a number of samples to achieve this. If the division factor for the system clock is 2, 4, 8, 16, or 32, an average of 2, 4, 8, 16 or 32 incoming samples is taken and passed on further. The result is a gain in the number of effective bits of the analog-to-digital conversion.

High-pass filter: A first order IIR high-pass filter with a variable 3 dB point is implemented. This can be used to filter the remaining DC jump on defects (analog HPF will have filtered off most). The cutoff frequency of the digital high-pass filter can be changed on the fly, by writing to register HighPassFiltCont.

It is possible to reset the state of the high-pass filter, via bit 6 of register HighPassFiltCont. The input and the output of the high-pass filter is 8 bits wide.

The high-pass filter is implemented in a '1 minus low pass' structure. It is possible to hold the low-pass filter on defects. For more information, see [Section "Defect Detector" on page 25](#).

The high-pass filter is driven by the system clock. Its bandwidth is also proportional to the sysclk.

An approximate formula for the cutoff frequency, f_c , of the high-pass filter is

$$f_{c,HPF} = \frac{HPSet[5:0]}{2\pi \times 2^{11}} \times f_{sysclk}$$

Peak detectors: There are 2 types of peak detectors present in the signal conditioning block.

The first type works on an immediate attack / slow decay basis, and is used for measuring peaks, amplitude and offset for readback by software sending peak information to the defect detector.

The second type works on the principle of detecting maximum and minimum peaks within a window, and is used for the AGC and AOC control logic.

Both sets of peak detectors will look at the RF after it has passed an optional noise filter. This noise filter is an LPF with a programmable high cutoff frequency. This bandwidth is programmed via register PDBandwidth(NOISEFILTERBW) for the noise filter before the peak detectors of AGC/AOC and measurement read back. The defect detector peak detector has its own noise filter which is programmed via register DefectDetPeakBW(NOISEFILTBW).

Peak detector with decay filter: The functional schematic of this peak detection is shown in [Figure 13](#).

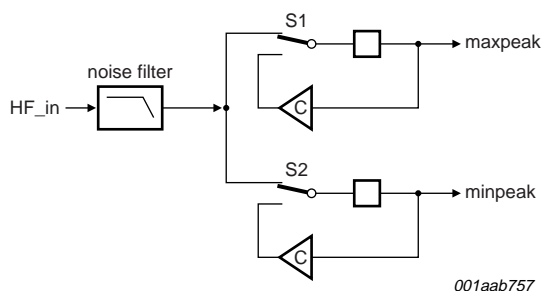

Fig 13. Peak detection diagram with decay filter

The minimum and maximum peaks of the incoming signal are measured. Switch S1 takes the largest value at its inputs. Switch S2 takes the minimum value at its inputs. The time constant of the decay filters has to be long. The same bandwidth is used for the decay filters of both the minimum and maximum peak detectors. The decay filter for the maximum peak responds to the smallest value possible. The decay filter for the minimum peak responds to the largest value possible.

The decay bandwidth of the measurement readback decay filter is controlled via register PDBandwidth(DECAYBW), the bandwidth of the defect detector is controlled via register DefectDetPeakBW(DECAYBW).

The following settings of the decay filters are possible: $C = 1 - 2^{-m}$, for $m = 6$ to 21 , where $m = \text{DECAYBW}[3:0] + 6$.

The corresponding bandwidths of the decay filter are shown in [Table 4](#), when the frequency of the system clock is 10 MHz.

Table 4: Time constants of the decay filters, at sysclk = 10 MHz

m	t (μs)	m	t (μs)	m	t (ms)	m	t (ms)
6	6.35	10	102.4	14	1.64	18	26.21
7	12.75	11	204.7	15	3.28	19	52.43
8	25.55	12	409.6	16	6.55	20	104.8
9	51.15	13	819.2	17	13.11	21	209.7

Peak detector based on window: The functional schematic of this peak detection is shown in [Figure 14](#).

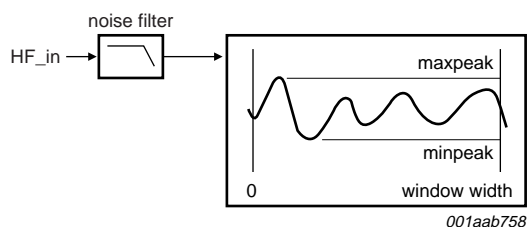

Fig 14. Peak detection diagram with window

The minimum and maximum peaks of the incoming signal are measured during a programmable window period. The highest and lowest value samples within this window are used to update maxpeak and minpeak.

The window width of the measurement is controlled via AGCAOControl(PDMEASWINDOW).

AGC and AOC control block: The AGC control block controls the RF amplitude at the input of the ADC by controlling the gain of an on-chip analog gain amplifier. The AOC control block controls the RF offset at the input of the ADC by adding or subtracting offset just before the ADC. Both AGC and AOC loops are built up in the same manner and are pictured in [Figure 15](#) with their relative position within the signal conditioning block.

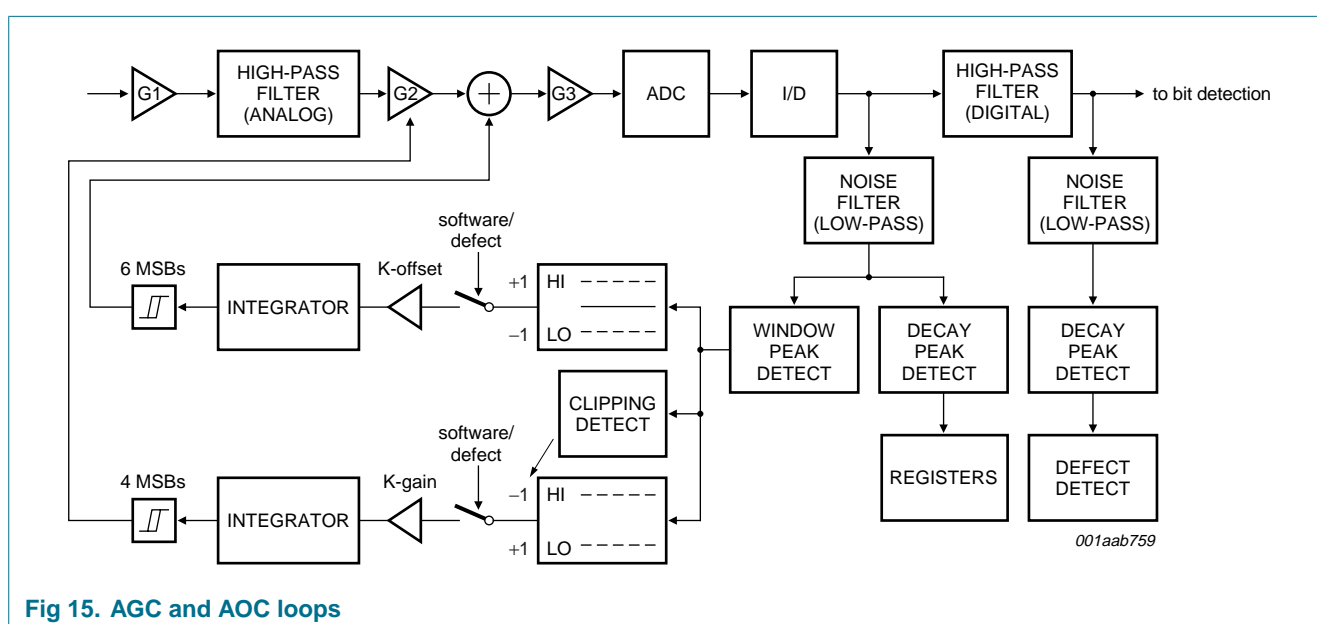

Fig 15. AGC and AOC loops

First, the maximum and minimum peaks on the envelope of the RF signal after the ADC are measured via a noise filter and the window peak detector (see [Section "Peak detectors" on page 21](#)). After that, the amplitude is calculated as $\text{maxpeak} - \text{minpeak}$, and the offset as $(\text{maxpeak} + \text{minpeak}) / 2$.

For tuning the loops, it is possible to read back the HFMaxPeak, HFMinPeak, HFAmplitude and HFOffset, as measured by the decay peak detector, from registers.

AGC control: The RF-amplitude at the ADC input can be changed with 2 gain amplifiers in the analog part: G1 (fixed) and G2 (dynamic). G1 has a gain-range from 0 dB to 24 dB in 16 steps of 1.6 dB, while G2 has a range from 0 dB to 12 dB in 16 steps of 0.8 dB. Both gains can be programmed via register AGCGain. G1 will stay fixed, while G2 can be regulated in hardware as soon as the AGC is turned on.

The AGC will regulate the gain such that the measured amplitude stays between a programmed upper threshold (AGCThrHi) and lower threshold (AGCThrLo). If amplitude is smaller, gain will increase; if amplitude is too large, gain will decrease. Whenever clipping is detected on one or two sides, gain will decrease as well. These gain changes are not sent to the analog gain amplifier directly, but are integrated over time. Only if on average a gain increase or decrease is requested, this will result in a real gain increase or decrease on the amplifier (the gain can also be read back via register AGCGain).

Together with the noise filter on the peak detector this prevents noise occurring on the RF which would result in volatile gain regulation. To decrease volatile behavior even further a hysteresis window with a width of one gain step has been added between the integrator and G2. The bandwidth of the gain loop will determine how fast it reacts on fingerprints and scratches, and can be programmed via register AGCIntegBW. It is also possible to limit the range of G2 by programming a maximum and minimum boundary (in register AGCGainBound).

AOC control: Most RF-offset at the ADC input will be removed by the analog HPF (first order HPF with 3 dB point around 3.6 kHz). The remaining offset (mainly introduced by the analog front-end itself), can be removed by adding or subtracting a fixed offset in the analog part. This offset subtraction or addition has a range of 32 steps in each direction, with approximately 1.4 LSBs per step (referenced to the RF-ADC). This leads to a full correction range of ± 42 LSB steps (more than the whole ADC range). This offset compensation value can be programmed via register OffsetComp, and will be regulated in hardware as soon as the AOC is turned on.

The AOC will regulate the offset compensation value such that the measured offset stays within a programmed window (OffsetBound). If offset is above this window, OFFSETCOMPVALUE will decrease; if it is below, it will increase. If an inversion occurs on the RF signal between analog and digital, this reaction of the loop can be inverted by programming OffsetBound(OffsetInv).

These offset changes are not sent to the analog offset subtraction directly, but are integrated over time. Only if on average an offset increase or decrease is requested, this will result in a real offset increase or decrease on the analog addition (can also be read back via register OffsetComp). Together with the noise filter on the peak detector this prevents noise occurring on the RF which would result in a volatile offset regulation. To decrease volatile behavior even further a hysteresis window with a width of one offset step has been added between the integrator and OffsetCompValue. The bandwidth of the offset loop will determine how fast it reacts on fingerprints and other defects, and can be programmed via register OffsetIntegBW. It is also possible to limit the range of the OFFSETCOMPVALUE by programming a maximum and minimum boundary (in register OffsetCompBoundHi and OffsetCompBoundLo).

AGC and AOC in general and rules of thumb: The AGC and AOC hardware regulation loops can be enabled and disabled separately by register AGCAOCControl. This register also allows the use of a slow AGC and / or AOC loop. In that case the programmed loop bandwidth is decreased with an extra factor of 128. In this mode the loops will be too slow to react on defects, but can be used for a slow software-like gain and / or offset regulation to regulate the average gain and offset over the disc nicely within a specified range.

An important feature is the AGCAOCControl(DISHOLDNOLock) bit, which disables holding of the AGC and AOC loops during defects (triggered by the defect detector, see [Section "Defect Detector"](#)) while the HF-PLL is not in lock. This feature avoids permanent lockups of the loops caused by a small amplitude triggering the defect detector, which in turn would hold the AGC loop.

As rule of thumb, the following should be taken into account:

The amplitude thresholds should be programmed not too close to each other, to allow at least 2 gain steps (1.6 dB) to go from lower to higher boundary and vice versa. This is to avoid a volatile AGC.

The offset boundary should be programmed not too tight, ± 8 is a good value. This is to avoid a volatile AOC.

The BW of the loops should never be programmed too high ('fast') with respect to the peak detector measurement window, to avoid an unstable loop. If the PDwindow = 2^n sysclk's wide, the BW of the loops should never be higher than $2^{-(n+1)}$.

Defect Detector: The purpose of the defect detector is to detect the presence of black or white dots in the RF-stream, and to freeze some signal conditioning and bit recovery logic during these defects. This will prevent the control loops drifting away from their optimal point of operation whilst there is no RF present, so they can recover quickly when good RF is present again.

The detection of a defect is based on amplitude. The amplitude is measured via a set of peak detectors with decay, as described in [Section "Peak detectors" on page 21](#). The programming of the decay bandwidth and noise filter bandwidth is done by register DefectDetPeakBW.

Two thresholds can be programmed. A low threshold will trigger a 'defect-detected' signal as soon as amplitude goes below this threshold. A high threshold will clear this 'defect-detected' signal again as soon as amplitude goes above this threshold. Together these thresholds add an hysteresis to the defect detection, which avoids a jittery 'defect-detected' signal (switching on/off many times) when amplitude is on the edge. Thresholds are programmed in register DefectDetThres.

The defect-detected signal can be used to hold the PLL, slicer, AGC, AOC and HPF during a defect. Which feature(s) will be held can be programmed in register DefectDetEnables. The same register can be used via software to force the PLL, slicer and HPF into hold mode. The AGC and AOC can be held in software by just disabling the loops in register AGCAOControl.

Two special features exist on the defect detector:

- It is possible to delay the enabling and disabling of hold features at the beginning and end of a defect. This can be done by programming a start and / or stop delay (in number of sysclks) via register DefectDetStartStopDelay. Whenever the defect detector detects the start of a defect, the detector will wait for the start delay before triggering a defect-detected-processed signal. When the defect detector detects the end of a defect, the detector will wait for the programmed stop delay before clearing the defect-detected-processed signal again. This also means that defects which are smaller than the start delay are ignored and, that if the defect contains zones with good RF amplitude but smaller than the stop delay, they are ignored as well. In reality all hold features are triggered by the defect-detected-processed signal, rather than the defect-detected signal; but after rest of the decoder, both delays are zero, so both signals are equal.
- It is possible to program a time-window after the end of a defect, during which higher PLL and / or slicer bandwidths can be used (to speed-up the recovery of these loops after the defect). This window can be programmed via register DefectDetHighBWDelay, the programming of the bandwidths is explained in [Section 6.6.5.2 "Bit detector" on page 26](#).

The detection of the beginning or end of a defect, with and without start and stop delays, can be used to generate an interrupt. This is programmed in register InterruptEnable1.

6.6.5.2 Bit detector

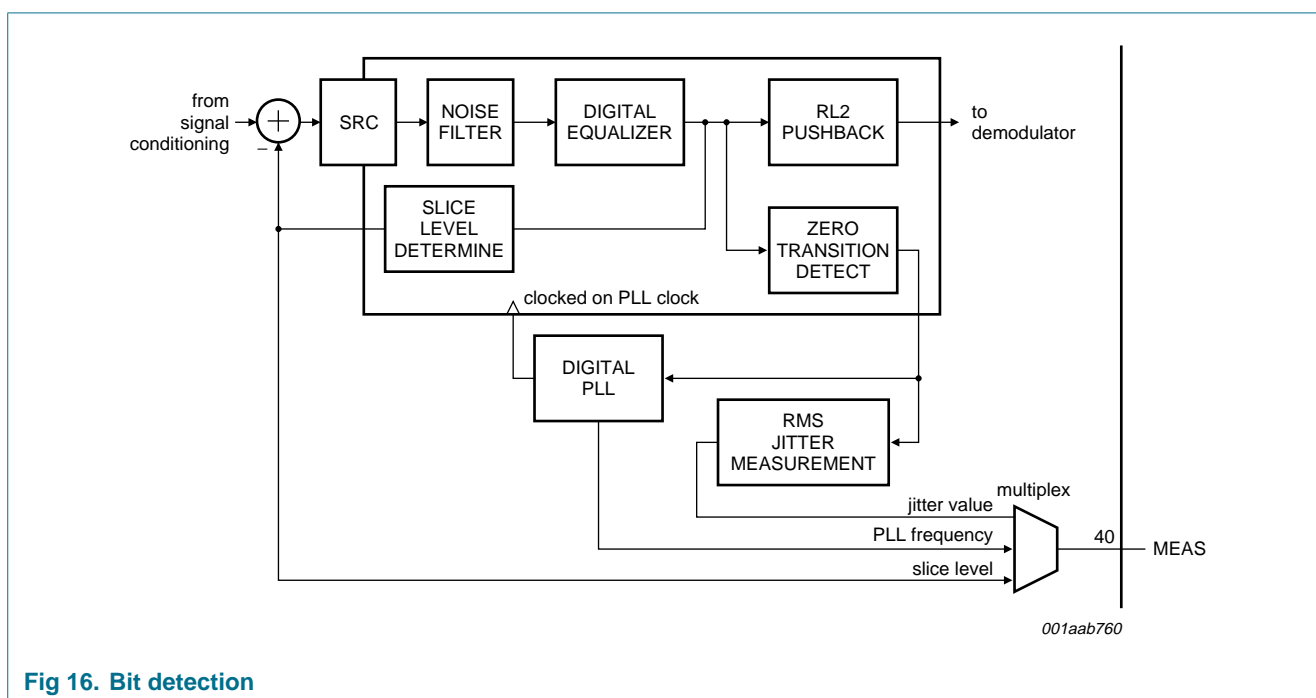

Fig 16. Bit detection

The bit detector block contains the slice level circuitry, a noise filter to limit HF-EFM signal noise contribution, an equalizer, a zero-transition detector, a run length pushback circuit, a digital PLL and jitter measurement logic.

All processing is done using the bit clock, and bandwidths are proportional to the channel bit rate. To achieve this, RF data is resampled in the system clock domain to the bit clock domain by using a sample-rate convertor. Blocks can be configured under microprocessor control and are described in detail in the next paragraphs.

Noise filter: The digital noise filter runs on the channel bit clock frequency f_b . It will limit the bandwidth of the incoming signal to $\frac{1}{4}$ of the channel bit clock frequency:

Pass band: $0f_b$ to $0.22f_b$

Stop band: $0.28f_b$ to $(f_b - 0.28f_b)$

Rejection: -28 dB.

Slice level determination: The slice level determination circuit compensates the incoming signal asymmetry component. Bandwidth of the slice level determination circuit is programmable via register SlicerBandwidth. Also the higher bandwidths for use after a defect (see [Section "Defect Detector"](#)) are programmed in this register. The bandwidth is proportional to the channel bit clock frequency. The slice level, or asymmetry, can be read back via register SlicerAssym.

Equalizer: In the bit detection circuit, a programmable equalizer is used, it boosts the high frequency content of the incoming signal.

A five-tap presentable, asymmetrical equalizer is built in. The equalizer block diagram is given in [Figure 17](#).

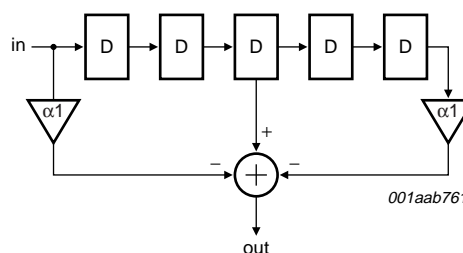

Fig 17. Equalizer

The first and last tap can be programmed via register PLLEqualiser.

Usable EFM bit clock range: The channel bit clock frequency should always obey the following constraints:

It should be less than $2 \times f_{\text{sys}}$

It should be larger than $0.25 \times f_{\text{sys}}$

Or: $0.25 < f_{\text{bit}} < 2$.

Only in this range a reliable bit detection is possible. If input channel bit rate is above $2 \times f_{\text{sys}}$ then the PLL will saturate to two times the system clock frequency f_{sys} .

Remark: While these are theoretical limits, a real-life application should keep a safety margin. When the bit clock is relatively low, the internal filter will filter off more noise, yielding a better performance. If the theoretical upper limit is approached, playability (e.g. black dot performance) will drop significantly. The decoder will only be able to correct the biggest correctable burst error of 16 frames if $f_{\text{bit}}/f_{\text{sys}} < 1.7$.

Taken this restriction on the decoder into account, the range is:

$0.25 < f_{\text{bit}}/f_{\text{sys}} < 1.7$.

Digital HF PLL: The digital PLL will recover the channel bit clock. The capture range of the PLL itself is very limited. To overcome this difficulty, two capture aids are present. When using automatic locking, the PLL will switch state based on the difference between expected distance and actual distance between syncs.

In total, three different PLL operation modes exist:

In-lock (normal operation); the PLL frequency matches the frequency of the channel bits with an accuracy error less than 1 %

Inner lock aid (capture aid 1); the PLL frequency matches the frequency of the channel bits with an accuracy error between 1 % and 10 %

Outer lock aid (capture aid 2); the PLL frequency deviates more than 10 % from the channel bit frequency.

First, PLL operation during in-lock is explained. This is the normal on-track situation. After this, the lock-detection and the two capture aids are explained.

PLL in-lock characteristics: The PLL behavior during in-lock can best be explained in the frequency domain. PLL operation is completely linear during in-lock situations. The open-loop response of the PLL (Bode diagram) is given in [Figure 18](#).

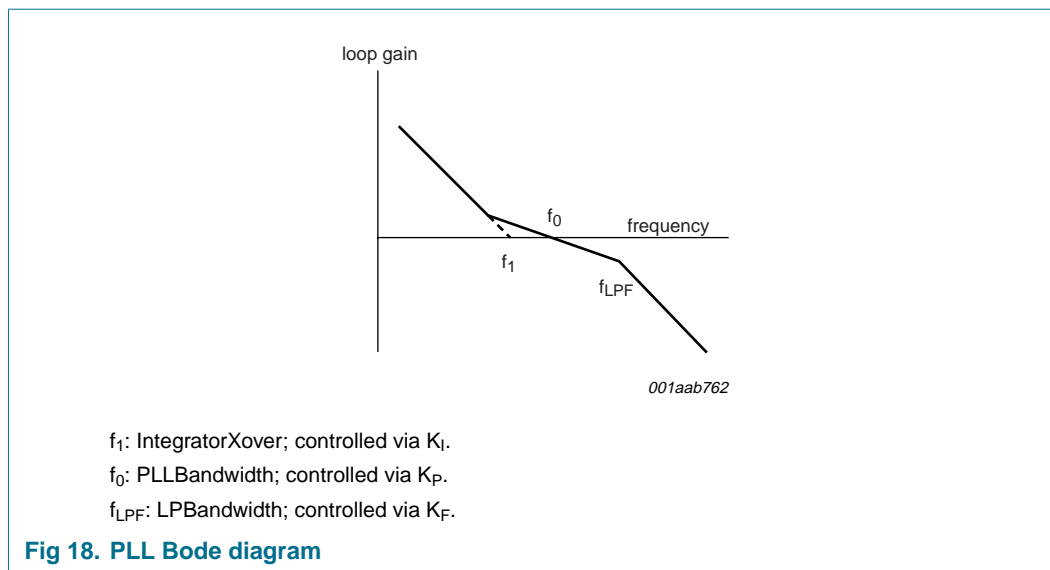

The frequencies f_0 , f_1 and f_{LPF} are programmable using register PLLBandWidth. The higher bandwidths for use after a defect (see [Section "Defect Detector" on page 25](#)) are programmed in register PLLBandWidthHigh.

When the PLL is in-lock the recovered PLL clock equals the channel bit clock.

Detection of PLL lock: The PLL locking state is determined by the distance between detected syncs. This means that the sync detection is actually doing the control of the automatic PLL locking.

The PLL switches from outer lock to inner lock when successive syncs are detected to be 588 ± 25 channel bits apart. Internally this is also called a winsync (sync falls in a wider window). The number of missed winsyncs is kept in a 3 bit confidence counter, and the PLL will go out of outer lock when 7 consecutive out-of-window syncs are found.

The PLL switches from inner lock to in-lock when successive syncs are detected 588 ± 1 channel bits apart. The number of consecutive missed syncs is kept in a bit counter, and saturates on either 16 or 61, depending on the value of bit lock 16 or 61 in register DemodControl. When the saturation level is reached, the PLL is set out of lock.

The PLL frequency (inner) and phase (in) lock status can be read out in register PLLLockStatus.

PLL outer lock aid: The outer lock aid has no limitation on capture range, and will bring the PLL within the range of the inner lock aid. The PLL will first regulate it's frequency based on detecting RL3s as the smallest possible RLs (fast but rough regulation), and next on detecting RL11s as the largest possible RLs (slow but more accurate).

PLL inner lock aid: The inner lock aid has a capture range of $\pm 4\%$, and will bring the PLL frequency to the phase-lock point. It will regulate the PLL frequency such that 588 bits are detected between 2 EFM-syncs.

Influencing PLL behavior: Programmability and observability is built into the PLL mainly for debugging purposes, and also to make difficult applications possible. The PLL operation can be influenced in two ways. First, it is possible to hand-select the state the PLL is in (in-lock, inner lock, outer lock, outer lock with only RL3 regulation). Second, it is possible to pre-set the PLL frequency to a certain value.

Overruling the PLL's state:

PLL state can be:

- In-lock
- Inner lock
- Outer lock
- Outer lock with RL3 regulation only
- Hold.

Normally, selection is done automatically using the lock detectors. Selection can be overruled via register PLLLockAidControl. When LOCKMODE is left to '0', user can still select lockstate, but hardware will overwrite this if hardware selected lockstate means closer to lock.

Table 5: PLL states

LOCKMODE	PLLLockControl	Meaning
0	00000	automatic lock behavior
1	00001	force HF PLL into in-lock
1	00110	force HF PLL into inner lock aid
1	00100	force HF PLL into outer lock aid
1	01000	force HF PLL into hold mode
1	10100	force HF PLL into outer lock aid with RL3 regulation only
x	others	reserved

Remark: During PLL hold' the frequency will not change and the frequency pre-set may be used.

Writing the PLL frequency: It is possible to preset the PLL frequency to a certain value. This is done by writing the integrator value of the PLL in register PLLIntegrator. The relationship between the bit frequency, the integrator value, and the sysclk frequency is

$$\text{given by: } f_{channelbit} = \frac{PLLFreq[7:0] + 4}{128} \times f_{sysclk}$$

The real-time value of the PLL frequency can be read on the same address.

6.6.5.3 Limiting the PLL frequency range

The range over which the PLL can capture the input frequency can be limited. The minimum and maximum PLL frequencies are set in bits MININTFREQ respectively MAXINTFREQ of register PLLMinMaxBounds.

6.6.5.4 Run length 2 pushback detector

If this circuit is switched on, all run length 1 (RL1) and run length 2 (RL2) symbols (invalid run lengths) are pushed back to run length 3 (RL3). For RL2s, the circuit will determine the transition that was most likely to be in error, and shift transition on that edge. This feature should always be turned on, but can be deselected via register RL2PushBack.

6.6.5.5 Available signals for monitoring

The operation of the bit detector can be monitored by the microprocessor and using an external pin. Several signals are made available for measurement.

PLL frequency signal: The first signal that can be monitored is the PLL frequency signal. Monitoring via the microprocessor is done by reading the register PLLIntegrator.

Asymmetry signal: The second signal that can be monitored is the 8-bit asymmetry signal. The signal is in 2-complement form and can be read from register SlicerAssym.

Jitter signal: A jitter measurement is done internally. The zero-crossing jitter is available in register PLLJitter.

The jitter measurement is done in two steps.

First, the distance between the EFM zero transition and the bit clock zero transition is measured.

Table 6: Jitter input calculation

Distance ($\times f_{\text{bit}}$)	Average distance (bit clocks)	Jitter filter input (5-bit decimal integer)
$< \frac{2}{16}$	$\frac{1}{16}$	1
$\frac{2}{16}$ to $\frac{4}{16}$	$\frac{3}{16}$	9
$\frac{4}{16}$ to $\frac{6}{16}$	$\frac{5}{16}$	25
$> \frac{6}{16}$	$\frac{7}{16}$	49

Second, the calculated jitter for the zero transition is averaged using a 10-bit low-pass filter. The top 8 bits of the filter output can be read back from register PLLJitter. To obtain the jitter in % of the channel bit clock, the following formula applies:

$$jitter = \sqrt{\frac{jitter[7:0] - 2.83}{1024}} \times 100 \%$$

This jitter measurement is also available via the telemetry signal on pin MEAS. On this signal, the full 10-bit output of the filter is available - see [Section 6.6.5.6 "Format of the measurement signal on MEAS pin"](#).

It is also possible to read out an average jitter value via register PLLAverageJitter. This value is an average over a period of 8000 bit clocks on the normal jitter value. The formula to transform this into % is the same:

$$average\ jitter = \sqrt{\frac{average\ jitter[7:0] - 2.83}{1024}} \times 100 \%$$

Use of jitter measurement: The jitter measurement is an absolute-reference jitter measurement. It gives the average square value of the bit detection jitter. The jitter is measured directly before the bit detection in this device, and contains contributions due to various imperfections of the complete signal path: (Note that bit-to-clock jitter is measured.)

- Disc
- Analog preamplifier
- AD converter
- Limited bandwidths in this device
- Limited PLL performance
- Influenced by internal noise filter, asymmetry compensation, equalizer.

The jitter measurement is absolute-reference, because it relates directly to the EFM bit error rate if the disc noise is gaussian.

Internal lock flags: The fourth signal that can be monitored are three flags in the PLLLockStatus register: the internally generated inner lock signal FLOCK, the internally generated lock signal INLOCK and a LONGSYM(bol) flag when run length 14 is detected. (Too high run length).

In automatic mode, the FLock and INLOCK flags determine what type of PLL capture mode is used.

Table 7: Determining the current PLL capture mode

FLOCK FLag	INLOCK Flag	Capture mode
0	0	outer lock aid
1	0	inner lock aid
x	1	in-lock

6.6.5.6 Format of the measurement signal on MEAS pin

On this serial bus, which is output via pin MEAS and should be monitored using CL1 (available via another pin), three measurement signals are multiplexed together. [Figure 19](#) gives details on the format.

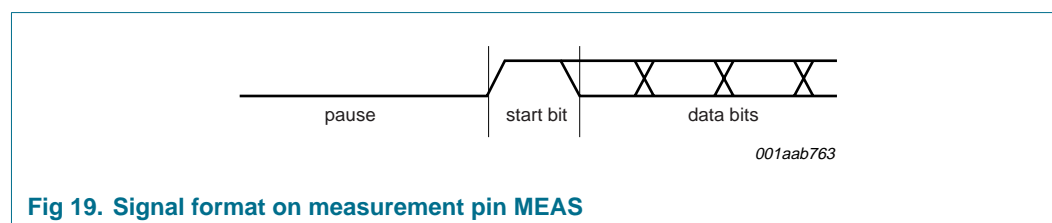

Fig 19. Signal format on measurement pin MEAS

The data is sent in a serial format. It consists of a pause, followed by a start bit. The start bit is followed by data bits. The bit length is four system clock periods, the frame length is 64 bits and the data format is shown in [Table 8](#).

Table 8: Data format on measurement pin MEAS

Bit number	Value	Description	Note
0	1	start bit	[1]
1 to 10	jitter[9:0]	first sample of jitter word	[2]
11	0		
12	1	intermediate start bit	
13 to 22	pllfreq[9:0]	PLL frequency word	
23	0		
24	1	intermediate start bit	
25 to 32	asym[7:0]	slicer level	
33 to 35	0		
36	1	intermediate start bit	
37 to 46	jitter[9:0]	second sample of jitter word	[2]
47 to 63	0	pause	

[1] The start bit is always preceded by 17 pause bits. The intermediate start bits at bit locations 12, 24 and 36 guarantee that no other '1'-value is preceded by 17 '0'-bits. This allows a simple start bit detection circuit.

[2] The jitter word is sampled twice in every frame. The jitter in % is calculated with the following formula:

$$jitter = \sqrt{\frac{jitter[9:0] - 12.81}{4096}} \times 100 \%$$

6.6.5.7 Demodulator

The demodulator block performs the following functions

- EFM demodulation using a logic array
- sync detection and synchronization
- sync protection.

6.6.5.8 EFM demodulation

Each EFM word of 14 channel bits (which are separated from each other by three merging bits) is demodulated into one data byte using the standard logic array demodulation as described in the CD red book.

6.6.5.9 Sync detection and synchronization

The EFM sync pattern is a unique pattern which is not used anywhere else in the EFM data stream. It consists of 24 bits: RL11 - RL11 - RL 2. An internal sync pulse is generated when two successive RL11s are detected. A subsync pulse occurs when the beginning of a new subcode frame is seen. This is done by analyzing the subcode information: when two successive subcodes are subcode-sync-code S0 and S1, subsync will be activated.

6.6.5.10 Sync protection

The subsync pulse is protected by an interpolation counter, this counter uses the fact that a subcode frame is always 98 subcode symbols long.

The sync signal itself is also interpolated. If after 33 data bytes (= 1 EFM-frame), no new sync is detected, it is assumed that the bit detector has failed to correctly achieve it, and the sync signal is generated anyway, this is generally called an 'interpolated sync'. If

furthermore a new sync is detected in the data shortly after a previous sync signal (interpolated or real) no new sync signal will be generated, because this means the frame has 'slipped'. After enough data byte periods, the sync signals are allowed to pass again.

There is a small chance it is possible to detect 'false' syncs, causing corrupted EFM bits to form by accident in the combination RL11-RL11. If two (or three) of such false syncs are detected at the correct distance from each other, this would cause a false resync of the demodulator. Such resync could lead to a large number of samples being corrupted at the output of the CIRC decoder. Chance of false sync detection is highest during defects (black and white dots).

To prevent such false demodulator resyncs, two features have been built in, which are both programmable via register DemodControl:

- **ROBUSTCNTRESYNC**; this feature should always be turned on; when it is on, the demodulator will look for three (instead of two) consecutive syncs with correct in-between distance before resyncing; this will improve robustness to false syncs substantially
- **SYNCGATING**; when '1', the sync-detection is turned off during a defect, to avoid the detection of false syncs; when '0', sync detection is left on all the time; it should be noted that the defect detector needs to be setup properly before this feature can be used; therefore this feature is turned off by default after reset.

6.6.6 CD decoding

6.6.6.1 General

The decoder block performs all processing related to error correction and CIRC de-interleaving and uses an internal SRAM FIFO which provides the necessary data capacity for doing this. It also extracts the Q-channel subcode and the CD-TEXT information from the data stream and delivers it to the application via a register interface.

6.6.6.2 Q-channel subcode interface

The channel decoder contains an internal buffer which stores the Q-channel bytes of a CD-subcode-frame. This subcode can be retrieved by the microprocessor by accessing the registers SubcodeQStatus, SubcodeQData and SubcodeQReadend.

To start retrieving the subcode, the microprocessor must read the register SubcodeQStatus first. This register contains various status bits that indicate the status of the Q-subcode that may be read. When, after reading the register SubcodeQStatus, the QREADY bit is found '1', the Q-subcode interface will be blocked (indicated by QBUSY going to '1') to prevent a new subcode overwriting the current one. Bit QCRCOK indicates if the current subcode frame had correct data content by a hardware CRC check.

After reading SubcodeQStatus with QREADY = '1', the microprocessor may retrieve as many subcode bytes as required (max. 10) by issuing subsequent reads to register SubcodeQData.

The content of the Q-channel subcode in the main data area is described in [Table 9](#). For description of the content during the lead-in area, see CD red book.

Table 9: Subcode Q-channel frame content

Address/Byte	Name	Description	Remark
1	CONTROL/MODE		
2	TNO		
3	POINT		
4	REL MIN	Mod100	relative time
5	REL SEC	Mod 60	
6	REL FRAME	Mod 75	
7	ZERO	0 or incremented modulo 10	
8	ABS MIN	Mod100	absolute time
9	ABS SEC	Mod 60	
10	ABS FRAME	Mod 75	

After finishing subcode read the microprocessor must release the interface to allow the decoder to capture new subcode information. This is done by issuing a read to register SubcodeQReadend.

The availability of a new subcode frame will also trigger an interrupt if bit InterruptEnable2(SUBCODEREADYENABLE) is set.

6.6.6.3 CD-TEXT interface

The channel decoder contains an internal buffer which stores CD-TEXT information (format 4, available in the lead-in area). The buffer can hold one CD-TEXT pack for readback, while it receives at the same time the next pack.

The operation of the CD-TEXT readback interface is controlled via register CDTEXTControl. Bit FREEZEEN determines whether or not the internal buffer is frozen during readback (such that the next pack can not overwrite the current one before the microprocessor has finished reading). Bit CRCFAILEN determines whether or not packs with a failing CRC check are made available for readback.

This subcode can be retrieved by the microprocessor, by accessing the registers CDTEXTStatus, CDTEXTData and CDTEXTReadEnd.

To start retrieving the CD-TEXT pack, the microprocessor must read the register CDTEXTStatus first. This register contains various status bits that indicate the status of the CD-TEXT pack that may be read. When, after reading the register CDTEXTStatus, the TEXTREADY bit is found '1', the CD-TEXT interface will be blocked (indicated by TEXTBUSY going to '1') to prevent new subcodes overwriting the current one; at least if CDTEXTControl(FREEZEEN) is turned on. Bit TEXTCRCOK indicates if the current CD-TEXT pack had correct data content by a hardware CRC check.

After reading CDTEXTStatus with TEXTREADY = '1', the microprocessor may retrieve as many CD-TEXT bytes as required (maximum 16) by issuing subsequent reads to register CDTEXTData.

After finishing CD-TEXT read the microprocessor must release the interface to allow the decoder to capture new CD-TEXT information. This is done by issuing a read to register CDTEXTReadEnd.

Remark: If CDTEXTControl(FREEZEEN) is disabled, the interface is not held during readback, which means that the current CD-TEXT pack can be overwritten by the next one before all bytes of the current pack are read out. Such an event will be indicated by setting CDTEXTReadEnd(BUFFEROVERFLOW) to '1', so that it can be noticed by software at the end of the pack-read.

The availability of a new CD-TEXT pack will also trigger an interrupt if bit InterruptEnable1(CDTEXTREADYENABLE) is set.

6.6.6.4 Main data decoding

Data processing: The CD main data is de-interleaved and error-corrected according the CD red book CIRC decoding standards and uses an internal SRAM as buffer and FIFO. The C1 correction will correct up to two errors / EFM-frame, and will flag all uncorrectable frames as an erasure. The C2 error correction will correct up to two errors or four erasures, and will also flag all uncorrectable frames as an erasure.

The decoding operation is controlled by the DecoMode register. There are basically two decode operation modes:

- In flush mode, the de-interleaver tables are emptied, and all internal pointers are reset. No data is written into the buffer, no corrections are done, and no data is output
- In play mode, de-interleaver tables are filled, C1 / C2 corrections are done, and data is output (when available).

During flush mode, no data is output from the device. During play mode, data is output via the I²S-bus interface as soon as it is available in the internal FIFO.

[Figure 20](#) shows the operation of the FIFO and corrections during CD playback.

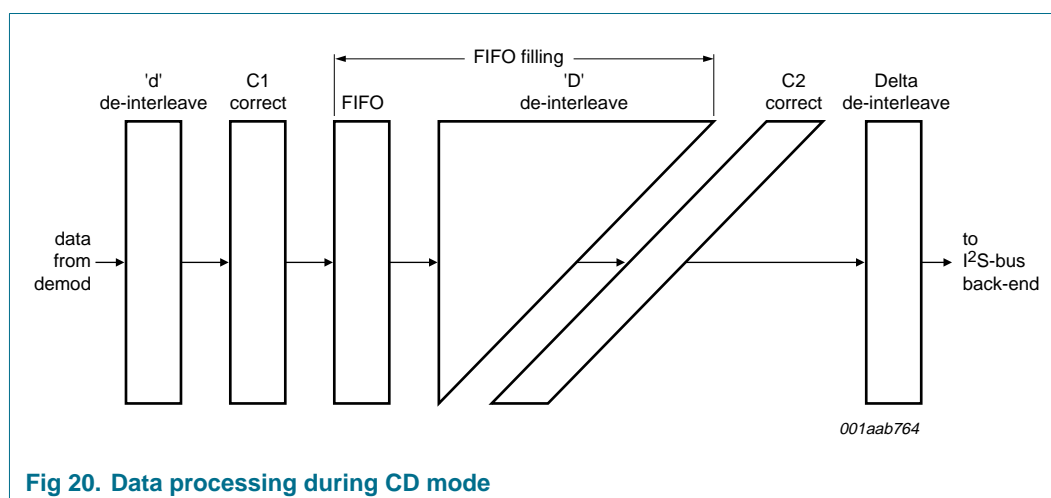

Fig 20. Data processing during CD mode

De-interleaving of the data is done in accordance with the red book specification. De-interleaving is performed by the SRAM FIFO address calculation functions in the memory processor. Two corrections are done - C1 followed by C2.

Data latency and FIFO operation: The system data latency is a function of the minimum amount of data required in the FIFO to perform the de-interleaving operation. The latency is quoted in the number of C1 frames (24 bytes of user data). The latency of the CIRC decoder is 118 frames.

The FIFO filling is defined as this 'data latency' plus the number of extra frames stored in the FIFO. The filling of the FIFO must be maintained within certain limits. 118 frames is the minimum required for de-interleaving and 128 is the physical maximum limit determined by the size of SRAM used. This results in a usable FIFO size of 11 frames. The status of FIFO filling can be read back via register FIFOFill.

The FIFO filling must have a correct value. This can be achieved in 2 ways:

- Master (Flow Control) mode: this mode is selected when using a gated bit clock (bclk) at the I²S-bus interface, see [Section 6.6.7.9 "I²S-bus interface" on page 41](#) for more information. As soon as a frame is available in the FIFO, it is output via the I²S-bus interface. When FIFO underflow is imminent, the decoder will gate off the output interface by disabling bclk.
- Slave (audio) mode: In this case, the bit clock is continuously clocking. The application is responsible for matching the input rate (EFM bit rate coming from the disc) to the selected output rate (I²S-bus bclk speed), and keeping FIFO filling between 118 and 128. This is done by regulating the disc speed. See [Section 6.6.8 "Motor" on page 44](#) for more details.

The FIFO is only storing data, not subcode. This means that the data will be delayed as it comes from the demodulator, but the subcode is sent straight over the I²S-bus interface. The difference in delay between subcode and data is always fixed. It is absolutely fixed in master mode, but can have small local variations during slave mode.

Safe and unsafe correction modes: The CD CIRC decoding standard uses a Reed-Solomon error correction scheme. Reed-Solomon error correction has always a very small chance of miscorrection, which means that a corrupted codeword is modified into a valid but wrong codeword. The chance of such miscorrections increases exponentially for every extra byte that needs to be corrected in a codeword, and is the highest when doing the maximum number of corrections possible with a certain Reed-Solomon correction scheme.

Miscorrections should be avoided, since they will result in corrupted data being sent to the back-end, without their corresponding invalid flag being set. Certainly for CD-Audio this is a problem, since unflagged wrong data will not get interpolated, which can result in audible clicks.

Both C1 and C2 correction logic can be programmed to operate in an 'unsafe' or 'safe' mode via register ErcoControl. In unsafe mode, the maximum number of corrections will always be done (if required). In safe mode, corrections will not be done when they are considered at risk, which means there is a realistic chance they could lead to a miscorrection.

For C1, unsafe mode will allow two bytes per codeword to be corrected, safe mode only one. For C2, both modes will allow up to four erasures per codeword to be corrected. When there are more than four erasures and therefore erco switches back to error correction, unsafe mode will allow two bytes to be corrected, safe mode only one.

Remark: From experiments and theory it is advised to use C1 unsafe and C2 safe for CD-Audio as a good trade-off between safety and maximum error correction capability. For CD-ROM C1unsafe and C2unsafe can be used, if there is at least a C3 error correction and if the flywheels in the CD-ROM block decoder are robust to possible invalid but unflagged headers.

6.6.6.5 Error corrector statistics

CFLG: The error corrector outputs status information on the CFLG pin. The format of this information is serial, similar to that used on the MEAS pin.

The serial format consists of a pause bit followed by a start bit. This start bit is followed by the data bits. The format of the data is explained in [Table 10](#). The bit length is 7 sysclk periods and the frame length is 11 bits.

Table 10: Format description of CFLG serial bus

Bit no	Value	Meaning	Note
0	1	start bit	[1]
1 to 3	CORMODE[2:0]	type of correction	[2]
4	FLAGFAIL	failure flag set because correction at risk	[3]
5	CORFAIL	failure flag set because correction impossible	[3]
9 and 6 to 8	ERRORCOUNT[3:0]	number of errors corrected	[4]
10	0	pause bit	[1]

[1] The repetition rate on the CFLG signal is not fixed. May be longer or shorter depending on disc speed and output interface speed. There is always at least one pause bit.

[2] CORMODE definition:
 '000': C1 correction
 '011': C2 correction
 '100': corrector not active
 Others: not used

[3] CORFAIL and FLAGFAIL indicate failure status on previous codeword

[4] ERRORCOUNT indicates the number of errors found in the Chien search.

BLER counters: There is also a set of two BLER counters which count the number of frames (C1 / C2) with at least one error (for C2, erasures coming from C1 will also be counted). It doesn't matter whether the frame was correctable or not.

These registers are reset on read, and the user is responsible for reading them in regular intervals. The BLER counters can be read on C1Bler and C2Bler.

6.6.7 Audio back-end and data output interfaces

The channel decoder back-end is shown in [Figure 21](#).

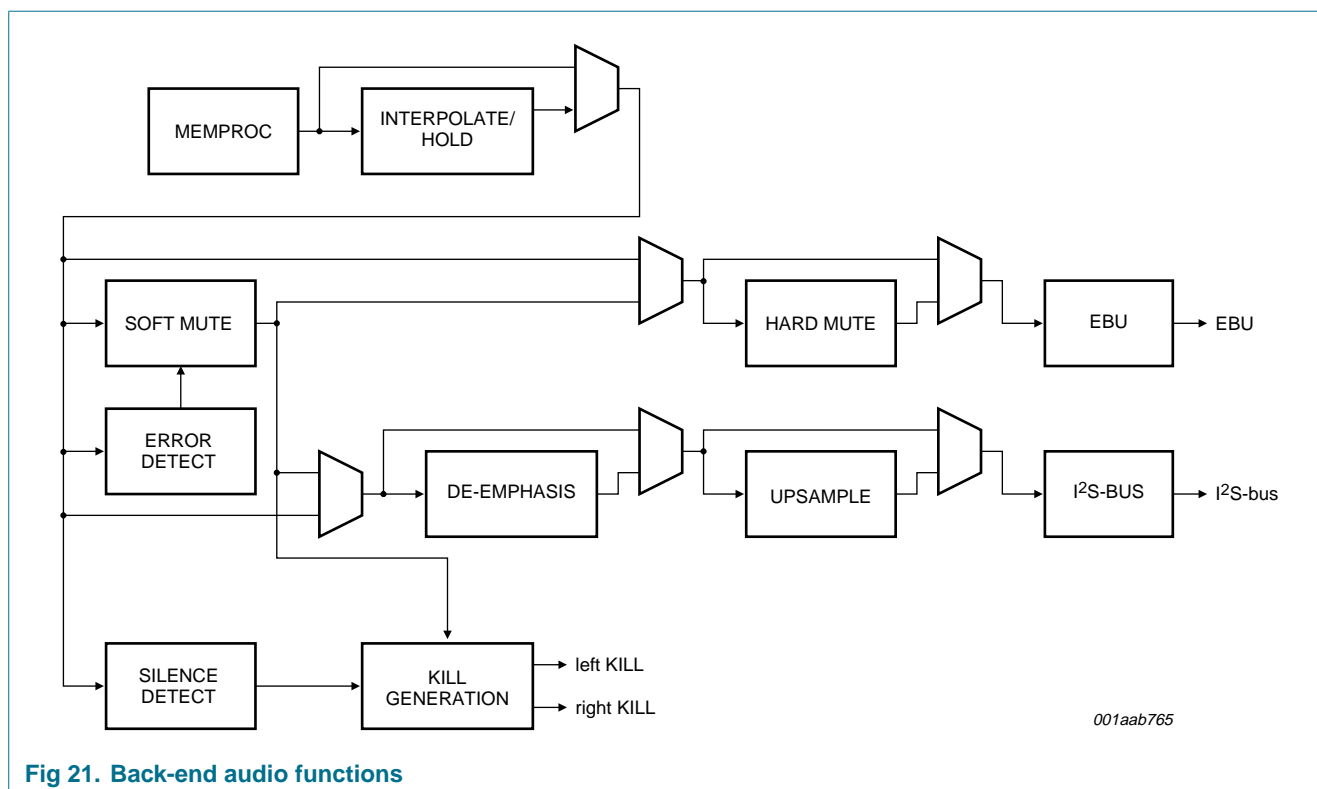

Fig 21. Back-end audio functions

Decoded and error corrected CD-data streams into the audio back-end from the memory processor to the output interfaces. Some audio filtering can also be done (in case of playing CD-DA).

6.6.7.1 Audio processing

The following audio features are present at the back-end:

- Interpolate / hold for I²S-bus and EBU
- Soft mute for I²S-bus and EBU
- Hard mute for EBU
- De-emphasis filter for I²S-bus
- Upsample filter for I²S-bus
- Error detection
- Silence detection
- Kill generation.

Some status bits concerning these audio features can be read back via register MuteKillStatus.

6.6.7.2 Interpolate and hold

On CD audio disks with many (large) defects, where C1 / C2 correction can not correct all errors, the audio data can be interpolated / held, to avoid audible clicks and plops when playing back the disk. This feature is enabled by setting FilterConfig(INTERPOLATEEN).

The principle is depicted in [Figure 22](#).

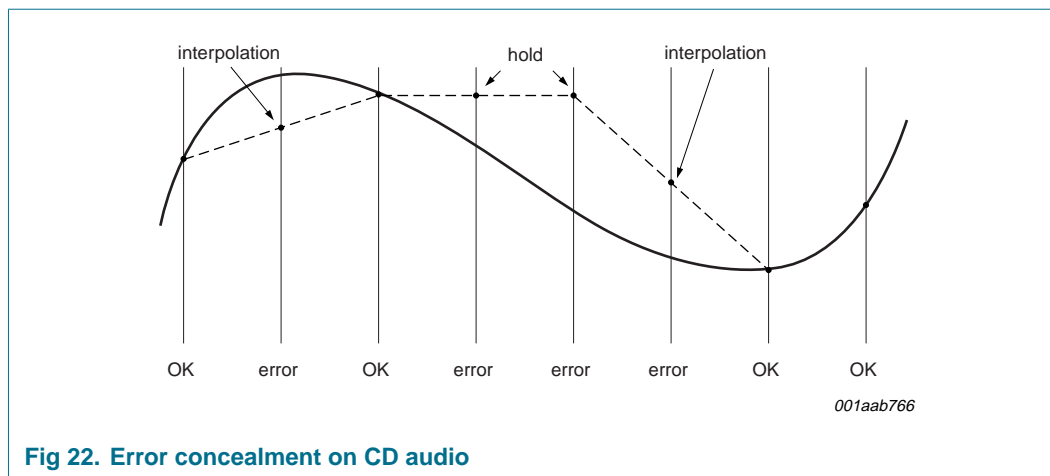

Fig 22. Error concealment on CD audio

Audio samples flagged as uncorrectable, neighbored by 2 good samples - or a held and a good sample, will be interpolated. Audio samples flagged as uncorrectable, which are not followed by a good sample, will hold the previous (correct or held) sample value.

This feature is enabled or disabled for I²S-bus and EBU together.

6.6.7.3 Soft mute and error detection

The audio data going to the I²S-bus and/or EBU interface can be processed by a soft mute block. This block can ramp the audio volume down from 0 dB to -90 dB, making use of 64 stages of about 1.5 dB each. The current stage can be monitored and changed in software by reading or writing register MuteVolume. This allows the implementation of a software mute-scheme. If the hardware mute logic is triggered by the error detection block (see [Section 6.6.7.4](#)), it will ramp the volume down from maximum till fully muted in 3/N ms, with N the X-rate of the disc. The mute logic can be enabled separately for the I²S-bus and EBU outputs, by setting the corresponding bits in register MuteConfig.

The back-end also contains an error detection block, that scans the data for a programmable number (via register MuteOnDefectDelay) of consecutive corrupted stereo samples. If such a pattern is found, and MuteConfig(MUTEERREN) is turned on, the softmute will be triggered to start its volume ramp down. This detection will also trigger a InterruptStatus1(AUDIOERRORDETECTED) interrupt.

6.6.7.4 Hard mute on EBU

The EBU can be hard muted (EBU main data and flags set to 0, status and user channel still valid) by setting EBUConfig(EBUHARDMUTE).

6.6.7.5 Silence detection and kill generation

The silence detector looks for 250 ms of digital silence (2's complement data = all '1's or all '0's) on either one or both channels and can trigger the kill-logic when it is found. Enabling of this feature is done via KillConfig(KILLSILENCEEN).

The kill-logic generates a left and a right kill signal, which are brought out of the channel decoder and can be used to gate the left and the right channel of an audio DAC. The kill signals can be triggered on both channels together by the detection of stereo-silence, or on each channel separately by the detection of mono-silence. Which operation is active depends on the setup in register KillConfig. It is also possible to set the left and right kill signals in software by writing directly to the KILLLEFT and KILLRIGHT bits in this register.

Another condition that will set both left and right kill signals is the soft mute block reaching 'fully muted' (volume-stage 0).

6.6.7.6 De-emphasis filter

This feature only affects the I²S-bus, not the EBU output. The de-emphasis filter can be used to remove pre-emphasis from tracks which have been recorded making use of the standard emphasis as described in the CD red book. The de-emphasis filter has the inverse response of the emphasis characteristics as described in the standard; see [Figure 23](#).

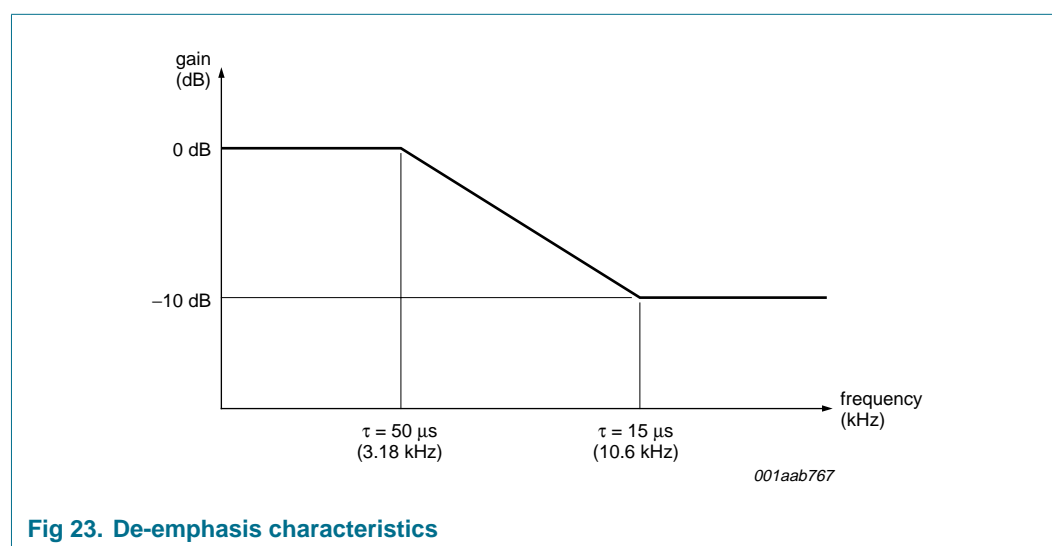

Fig 23. De-emphasis characteristics

Control over the de-emphasis filter is done via FilterConfig(DEEMPHCONTROL). The filter can be enabled or disabled under software control, or be fully automatic in hardware. In the latter case, the filter will be turned on when a pre-emphasis bit is detected in the control byte of the Q-channel subcode, and turned off when this bit is missing.

There are two possible detection modes:

- According to red book; only a pre-emphasis bit is checked (so is allowed to change) during the lead-in area, and during pauses between tracks
- According to orange book; pre-emphasis is checked on every subcode frame.

6.6.7.7 Upsample filter (four times)

This feature only affects the I²S-bus, not the EBU output. When it is enabled, the audio data will be upsampled by a factor of four. The upsampling provides the frequency response described in [Table 11](#).

Table 11: Upsample filter frequency response

Pass band	Stop band	Attenuation
0 kHz to 9 kHz	-	≤ 0.001 dB
9 kHz to 20 kHz	-	≤ 0.03 dB
-	24 kHz	≥ 25 dB
-	24 kHz to 27 kHz	≥ 38 dB
-	27 kHz to 35 kHz	≥ 40 dB

Table 11: Upsample filter frequency response ...continued

Pass band	Stop band	Attenuation
-	35 kHz to 64 kHz	≥ 50 dB
-	64 kHz to 68 kHz	≥ 31 dB
-	68 kHz	≥ 35 dB
-	69 kHz to 88 kHz	≥ 40 dB

When upsampling is enabled, the audio data output rate on the I²S-bus interface will be four times higher than without upsampling. Therefore the I²S-bus word clock (pin WCLK) frequency has to be four times higher. This means that the I²S-bus bit clock (bclk) speed needs to be programmed to be four times higher speed than normally required for that bit-rate when upsampling would be disabled.

Another result of the upsampling is that every sample will have 18 bits precision instead of 16 after the upsample filter. To make use of this extra bit-precision, the user should select 24-bit or 32-bit I²S-bus format. When using 16-bit I²S-bus format, the two lowest bits will not be output.

6.6.7.8 Data output interfaces

There are three interfaces via which data can be output from the channel decoder block.

- Main data can be output via I²S-bus
- Subcode can be output via the subcode interface
- Main data + subcode can be output via EBU/SPDIF.

All interfaces can be used at the same time if needed, although there are a few restrictions on the EBU, see [Section 6.6.7.10 “EBU interface” on page 42](#).

6.6.7.9 I²S-bus interface

The I²S-bus is a 6 wire interface (four main and two subcode). It supports 16-bit, 24-bit and 32-bit I²S-bus and EIAJ (Sony) modes. Timing is shown in [Figure 24](#). The required format can be selected in register IISFormat.

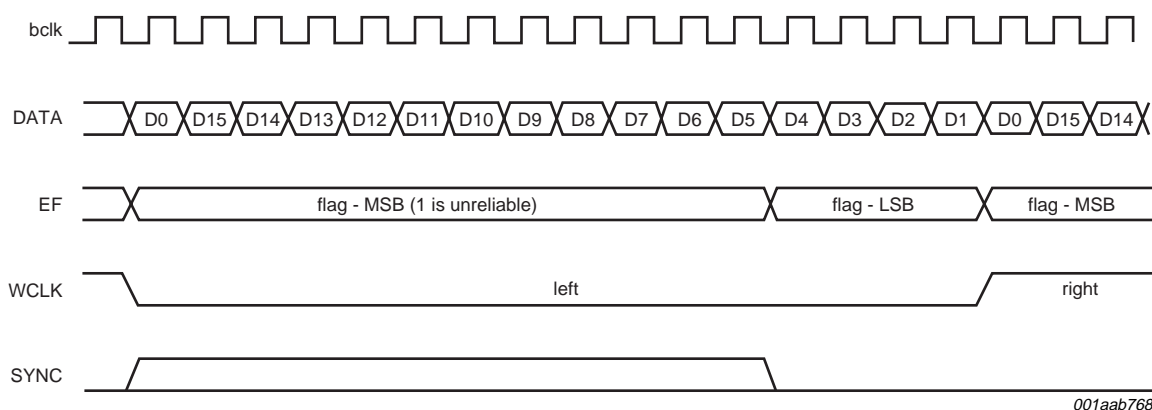
Fig 24. I²S-bus format 1; 16 clocks per word

Compliant with the I²S-bus specification, the I²S-bus signals WCLK, DATA, EF and SYNC are all clocked on the falling edge of the I²S-bus bit clock signal bclk:

- Bclk: all other I²S-bus signals are clocked on bclk
- WCLK: indicates the start of a new 16/18-bit word on the data line, and differentiates between left and right sample
- DATA: 16/18-bit data words are outputted via this line, 1-bit / bclk-period
- Error Flag (EF): contains the byte reliability flag; bytes that are indicated as erasures (possible errors) after C1 and C2 correction, are flagged.
- SYNC: indicates that the serial subcode line contains the MSB of a subcode word; it will be asserted every six WCLK periods for half a WCLK period. If a subcode sync is transferred on the subcode line, this signal will be asserted for a full WCLK period.

The I²S-bus interface can either work in master or slave mode. In master mode, the bclk can be gated off by the channel decoder. In slave mode, the bclk is continuously running. To prevent the internal FIFO from overflow, the filling of the buffer must be regulated (see [Section "Data latency and FIFO operation" on page 35](#)).

Bclk and WCLK can either be input (generated outside the channel decoder) or output (generated internally in the clock control block). Selection can be done via bits WCLKSEL and BCLKSEL in register IISConfig.

The I²S-bus output rate is determined by the speed of the bclk, which is configured via register BitClockConfig. The I²S-bus interface can be configured to run at 1 × or 2 × CD.

In case of gated bit clock, when BitClockConfig(BCLKGEN) is '1', the speed must be configured such that the maximum rate available on the bus is 20 % higher than the average data throughput rate. Or in other words: the bus should have at least 20 % idle time in between 2 bursts of data.

Default after reset, the I²S-bus pins on the IC will be put into 3-state. They can be activated via register IISConfig. This register also contains the possibility to kill the I²S-bus interface, such that all data line outputs go LOW.

6.6.7.10 EBU interface

The channel decoder contains a digital one wire EBU or SPDIF output interface. It formats data according to the IEC60958 specification. The EBU rate can be selected to be 1 × or 2 × CD, by programming register EBUClockConfig.

For proper operation of the EBU interface, the I²S-bus bit clock must be internally generated, bit clock gating must be disabled and the following relationship between EBUClk, bclk, WCLK and I²S-bus format must be true:

$$EBUClk = WCLK \times 64$$

Some fields in the user channel of the EBU-stream can be filled in by software, configured via register EBUConfig.

Bit IISConfig(KILLEBU) contains the possibility to 'kill' the EBU interface, so that the line outputs go LOW.

6.6.7.11 Subcode interface

Subcode data is output via the IISSubo (pin V4) port. This data can be sampled using the I²S-bus SYNC signal (see [Section 6.6.7.9 "I²S-bus interface" on page 41](#)). The SYNC indicates that the serial subcode line IISSubo contains the MSB of a subcode word. It will be asserted every six WCLK-periods for half a WCLK-period. If a subcode SYNC is transferred on the subcode line, this signal will be asserted for a full WCLK period.

During normal operation (upsampling disabled), the subcode output via IISSubo will have the format as shown in [Figure 25](#).

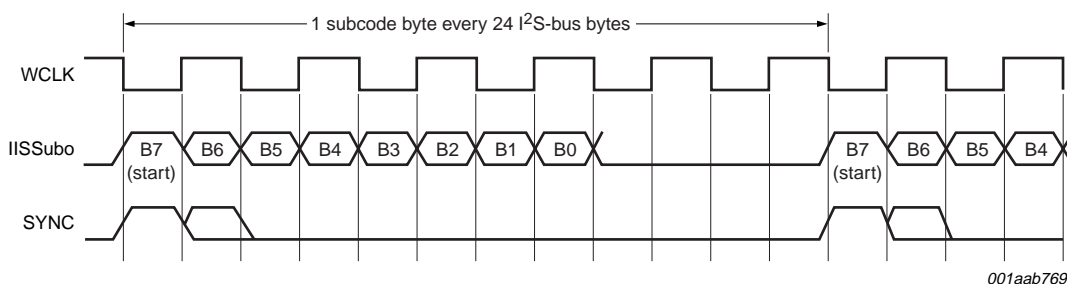

Fig 25. Subcode output; upsampling disabled

When upsampling is enabled, the I²S-bus interface will run at four times the non-upsampled rate. The subcode bit period however will stay at the non-upsampled rate as shown in [Figure 26](#). This means that the IISSubo and SYNC signal will appear to be four times slower relative to the WCLK. In this case the receiver must use the WCLK divided by four to sample the subcode.

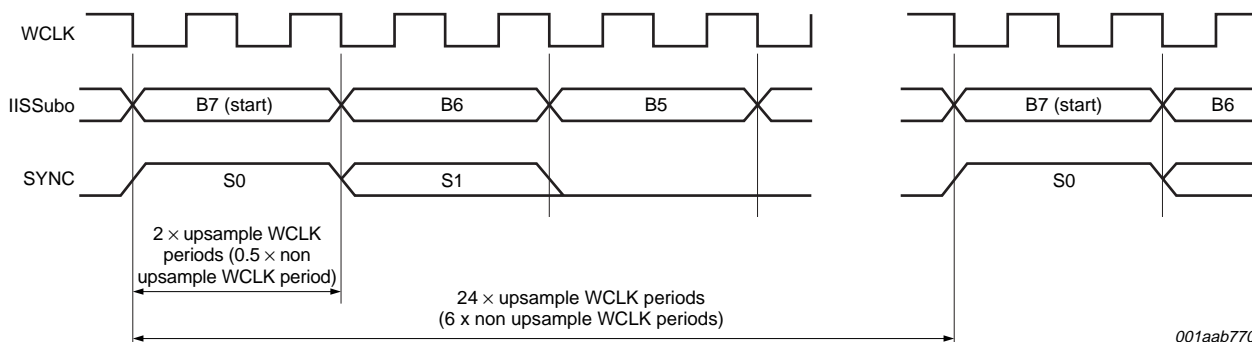

Fig 26. Subcode output; upsampling enabled

When slave mode is used, without bclk gating, it is also possible to use the IISSubo output port as a true single-line interface. In that case the receiver needs to sample the data on the line with a frequency equal to $f_{WCLK} \times 2$ (since subcode is output at a rate of one bit per half WCLK). Two characteristics of the interface can be used in this case to synchronize the bit and byte detection in the stream in the absence of a SYNC signal:

- The first bit (P-bit) of a subcode-byte is used as a start-bit and therefore always '1', (so no real P-channel information is available on the interface). Between two subcode bytes there are four zero-bits; this can be used to identify the start of the subcode bytes within the stream.

- The subcode syncs S0 and S1 are presented as all zeros on the interface (even P-channel), such that the last subcode byte of a subcode-frame, and the first byte of the next frame are separated by 28 zero-bits. This can be used to identify the start of the subcode-frames within the stream.

6.6.8 Motor

A block diagram of the motor interface is given in [Figure 27](#).

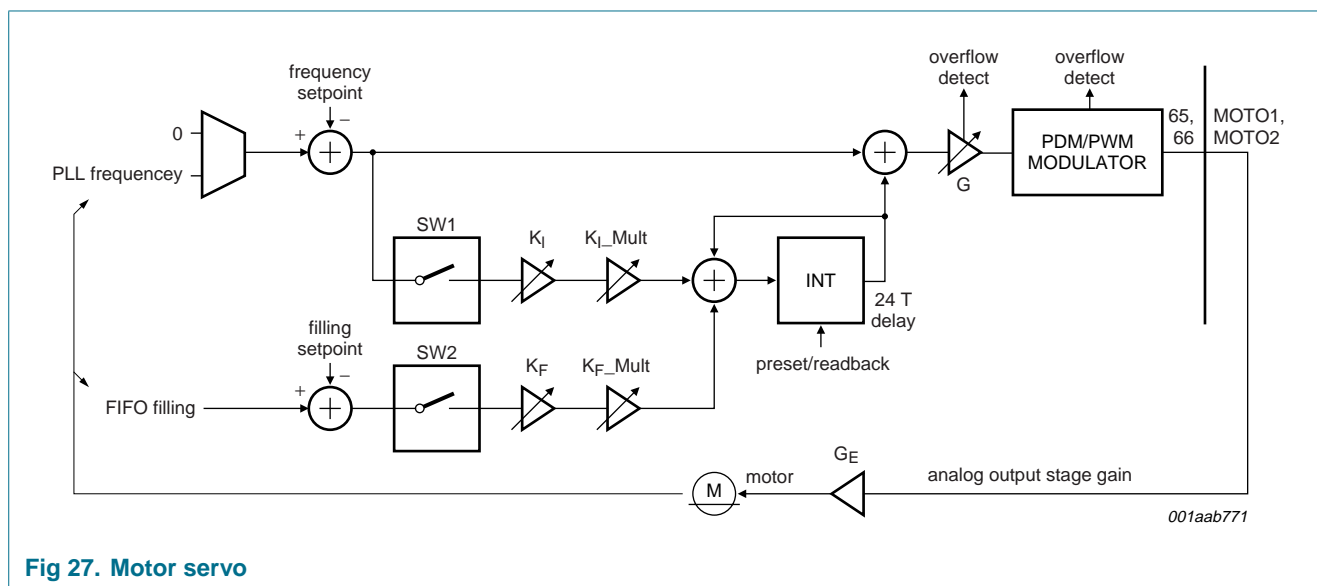

Fig 27. Motor servo

The motor interface consists of a PI filter and a PDM/PWM modulator. When put in a closed loop, the motor controller can control both speed, frequency and position error (FIFOFILL). It can be operated as a P, I or PI controller, by switching on and off the appropriate switches (*SW1* and *SW2*).

The frequency and position error integrator gain, K_I and K_F , and gain G are programmable. Frequency and filling set points are also programmable.

The frequency input source can be selected between PLL frequency and 0 Hz. The position input source is always FIFO filling.

When operated in a stable operation point in closed loop, the motor controller will regulate the frequency input source and the FIFO filling to their respective set points, this is implemented by speeding up or slowing down the motor by changing the DC content in the PDM/PWM output motor signals.

All motor parameters can be configured by programming the motor registers.

6.6.8.1 Frequency set point

When operating the motor in CLV mode, based on EFM, for a certain overspeed, the motor frequency set point to be programmed is given by

$$\text{motor frequency set point [7:0]} = 256 \times \left(1 - \frac{N \times 4.3218 \times 10^6}{2.667 \times f_{\text{sys}}} \right) \text{ where } f_{\text{sys}} \text{ is the system}$$

clock frequency and N the overspeed factor.

The set point can be programmed via register MotorFreqSet. The selection of the motor frequency input is programmed via MotorGainSet2(MotorFreqSource).

6.6.8.2 Position error

The position error will be used to fine tune the motor speed during 'slave mode', where the incoming EFM bit rate is locked on the programmed fixed I²S-bus bclk output speed. The set point must be chosen between 118 and 128, since this is the usable FIFO size in the decoder. See [Section "Data latency and FIFO operation" on page 35](#) for more information.

The set point can be programmed via register MotorFifoSet.

6.6.8.3 Motor control loop gains (K_P , K_F and K_I)

The control loop gains are all programmable through registers MotorGainSet1 and MotorGainSet2. To be able to set integrator bandwidth low enough at high system clock speeds an extra divider for the factors K_I and K_F is added. These factors can be written through the register MotorMultiplier.

The resulting $K_{I(tot)}$ is then the K_I multiplied by K_{I_Mult} . The resulting $K_{F(tot)}$ is then the K_F multiplied by K_{F_Mult} . The integrator bandwidth must be scaled with the same factor K_{I_Mult} .

Please note the following:

- K_{F_Mult} operates by sampling the input; e.g. for $K_{F_Mult} = 1$, every sample of the input is passed through the integrator circuit, for a K_{F_Mult} of 0.5, every second sample is passed through, for a K_{F_Mult} of 0.25, every fourth sample is passed through, and so on
- For a DC input signal, $K_F \times K_{F_Mult}$ should always give the same result. If however, the input varies quickly, the $K_F \times K_{F_Mult}$ combinations with the same product will not always give the same result, especially for low values of K_{F_Mult} , where the sampling in the extreme becomes 1 out of every 128 samples. (The input samples to the block that performs the K_{F_Mult} multiplication occur at a rate of 1 sample every 24 system clock periods.). Sub-sampling might affect the actual resulting gain.

6.6.8.4 Operation modes

The motor controller mode is programmed via register MotorControl. It can operate in open loop by just sending a fixed power to the motor for start-up and stopping, closed loop, or shut down. It also selects between PDM and PWM format.

Motor start and stop modes will put a fixed duty cycle PWM or fixed density PDM signal on the motor outputs. During start or stop, motor speed can be monitored by reading MotorIntLSB and MotorIntMSB.

MotorOv: When not setting the appropriate gains in the loop, an overflow might occur inside the PDM/PWM modulator block, or in the programmable gain stage. This is signalled by the MotorOv interrupt, which can be read back on InterruptStatus2. The interrupt disappears when the overflow disappears.

MotorOv can also automatically open *SW1* and *SW2*. This is enabled by writing a '1' to bit OVFSW in register MotorControl.

6.6.8.5 Writing and reading motor integrator value

It is possible to obtain the integrator value by reading the registers MotorIntLSB and MotorIntMSB. The integrator can be written at the same location. By opening all switches, the user can bypass the whole control and filter part, and just use the block as a DAC for the motor drivers. The control part can then be done in software.

6.6.8.6 Some notes on application motor servo

The motor servo can be used to control the motor during CLV playback and also during CAV or pseudo-CLV lock-to-disc or jump mode.

- In CLV mode, both SW1 and SW2 must be closed
- In CAV / pseudo-CLV mode, SW2 **must** be open and SW1 **may** be open
- The motor servo will revolve the disc at the speed corresponding to the frequency set point; in CLV mode with lock to EFM, the frequency set point must be set equal to the desired readout frequency of the HF-PLL
- Accelerating the disc must be done in one of the start modes
- Braking the disc must be done in one of the stop modes.

6.7 Digital Servo - PDSIC

The digital servo block on SAA7803 is an evolution of the design used for the SAA7824 IC, and is referred to as Parallel Digital Servo IC (PDSIC). The 'parallel' description refers to the microprocessor interface to the servo block; this is now a high speed parallel interface, whereas it was previously a serial interface (e.g. SAA7824 3/4 wire, I²C-bus). The other features of the PDSIC are:

- Programmable ADC for CD-RW playback compatibility
- Diode signal processing
- Signal conditioning
- Focus and radial control system
- Access control
- Sledge control
- Shock detector
- Defect detector
- Off-track counting and detection
- Automatic closed-loop gain control available for focus and radial loops
- High level features.

6.7.1 PDSIC Registers and servo RAM control

The servo block is controlled by two parts of the design - the servo control registers which are used to control the writing of commands and parameters to the servo; and the servo RAM. The servo RAM has two roles: storage of the servo parameters and capture of commands and parameters during the command process.

All of the servo write commands consist of a command byte followed by a number of parameter bytes (between 1 and 7), all of which have to be loaded into the PDSIC using a serial communication interface.

The command byte is the first to be loaded and can be considered as two nibbles. The upper (most significant) nibble represents the command itself whilst the lower (least significant) nibble tells the PDSIC how many parameter bytes to expect. The command byte gets placed into memory location 31h (called oldcom).

Subsequently, parameter bytes get loaded sequentially and these get placed into a stack space that has been reserved within the memory (locations 30h to 2Bh). With each parameter byte that is loaded, the value in oldcom is decremented. In other words, the byte count decreases until it reaches 0, then the PDSIC knows it has a complete servo command with a command byte and its full complement of parameter bytes. At this point, the PDSIC acts upon the command and the appropriate function is carried out based upon the values in the stack space.

There are two special case servo commands: Write_parameter (opcode = A2h) and Write_decoder_reg (opcode = D1h).

Write_parameter allows the microprocessor to write directly to any memory location. It carries two parameter bytes; the memory address and the data that is to be written. When this command is executed the command byte is loaded into oldcom and the first parameter byte (<RAM_address>) is loaded onto the stack. The second parameter byte (<data>) is loaded directly into the location specified by <RAM_address>.

Write_decoder_reg allows decoder registers to be written to when the I²C-bus interface is being used. This command carries only one parameter byte, which is the decoder register / data pair (2 nibbles). When this command is received by the PDSIC, the register / data pair is loaded into memory location 4Dh.

The servo read commands operate slightly differently in that they carry no parameter bytes and the lower nibble of the command byte is always 0 to indicate this. When the PDSIC receives a read command it will make certain information available (mostly from memory, although some status information is retrieved from the decoder) on the serial interface for collection by the microprocessor.

If a sequence of values are being read from the servo RAM (e.g. a series of values related to a PID loop), it is important to ensure that the values are consistent with each other, i.e. to ensure the servo has not updated some of the values during the period they are read. Therefore, an interrupt signal is available from the servo to the ARM which raises an IRQ when it is safe to read related values. This can also be monitored by the state of the servo register bits SRV_FC0 and SRV_FC1 shown in [Table 13](#). The interrupt generator monitors these signals and raises an IRQ whenever the correct state is achieved. Applying a pulse to the 'inreq_clr' register bit will then clear the interrupt. If the interrupt is not cleared, it will automatically be reset when the valid reading state is no longer true.

[Figure 28](#) shows the operation of the IRQ signal. Int #1 shows the full duration of an interrupt that does not get cleared by the ARM. Int #2 and Int #3 are shown being cleared by pulses being written to the inreq_clr register. The time between interrupts is approximately 15 μ s and the total interrupt cycle time is approximately 60 μ s.

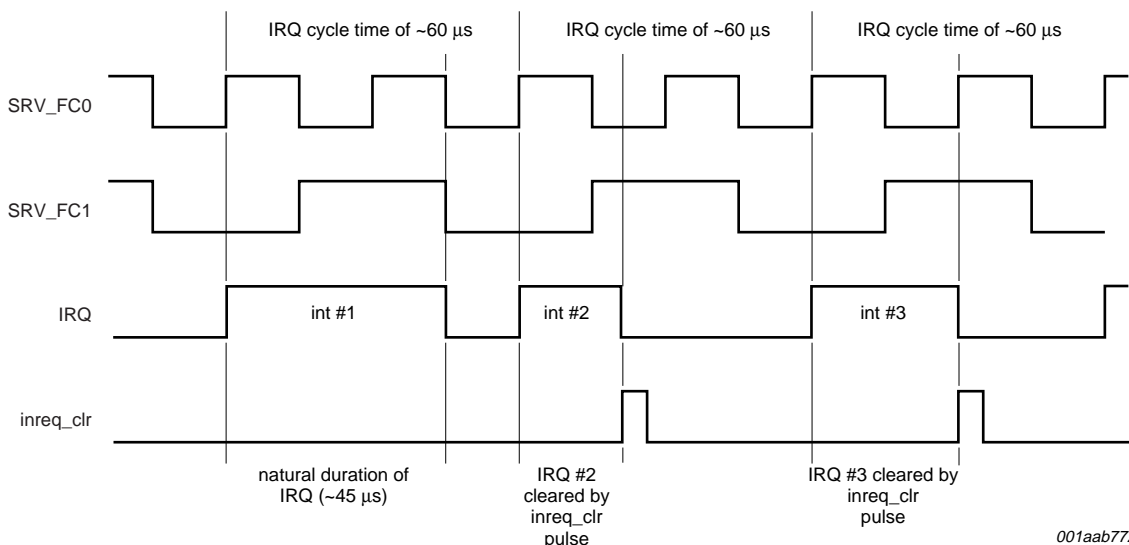

Fig 28. Function of servo IRQ signal

From a system perspective, the simplest configuration provides an LF path that is equivalent to the hardware servo (DSICS) of the other audio devices such as SAA7826, which uses the onboard hardware servo controller logic. However, an alternative setup will provide additional fine DC-offset compensation (in addition to the coarse compensation already found in the analog ADCs) and the potential for full software servo control via the ARM microprocessor.

6.7.2 Diode signal processing

The photo detector in conventional two-stage three-beam compact disc systems normally contains six discrete diodes. Four of these diodes (three for single focault systems) carry the Central Aperture (CA) signal while the other two diodes (satellite diodes) carry the radial tracking information. The CA signals are summed into an HF signal for the decoder function and are also differenced (after analog to digital conversion) to produce the low frequency focus control signals.

The low frequency content of the six (five if single focault) photodiode inputs are converted to PDM bit streams by a multiplexed 6-bit ADC followed by a digital PDM generation circuit. This supports a range of OPUs in voltage mode mechanisms by having sixteen selectable gain ranges in two sets, one set for D1 to D4 and the other for R1 and R2.

6.7.3 Signal conditioning

The digital codes retrieved from the ADC and PDM generator are applied to logic circuitry to obtain the various control signals. The signals from the central aperture diodes are processed to obtain a normalized Focus Error (FE) signal:

$$FE_n = \frac{D1 - D2}{D1 + D2} - \frac{D3 - D4}{D3 + D4} \quad \text{where the detector set-up is assumed to be as shown in}$$

[Figure 20](#).

In the case of a single focault focusing method, the signal conditioning can be switched under software control such that the signal processing is as follows:

$$FE_n = 2 \times \frac{D1 - D2}{D1 + D2}$$

The error signal, FE_n , is further processed by a Proportional Integral and Differential (PID) filter section.

An internal flag is generated by means of the central aperture signal and an adjustable reference level. This signal is used to provide extra protection for the Track-Loss (TL) generation, the focus start-up procedure and the dropout detection.

The radial or tracking error signal is generated by the satellite detector signals R1 and R2. The Radial Error (RE) signal can be formulated as follows:

$$RE_s = (R1 - R2) \times re_gain + (R1 + R2) \times re_offset$$

where the index 's' indicates the automatic scaling operation which is performed on the radial error signal. This scaling is necessary to avoid non-optimum dynamic range usage in the digital representation and reduces the radial bandwidth spread. Furthermore, the radial error signal will be made free from offset during start-up of the disc.

The four signals from the central aperture detectors, together with the satellite detector signals generate a Track Position Indicator (TPI) which can be formulated as follows:

$$TPI = \text{sign}[(D1 + D2 + D3 + D4) - (R1 + R2) \times \text{sum_gain}]$$

where the weighting factor sum_gain is generated internally by the SAA7803 during initialization.

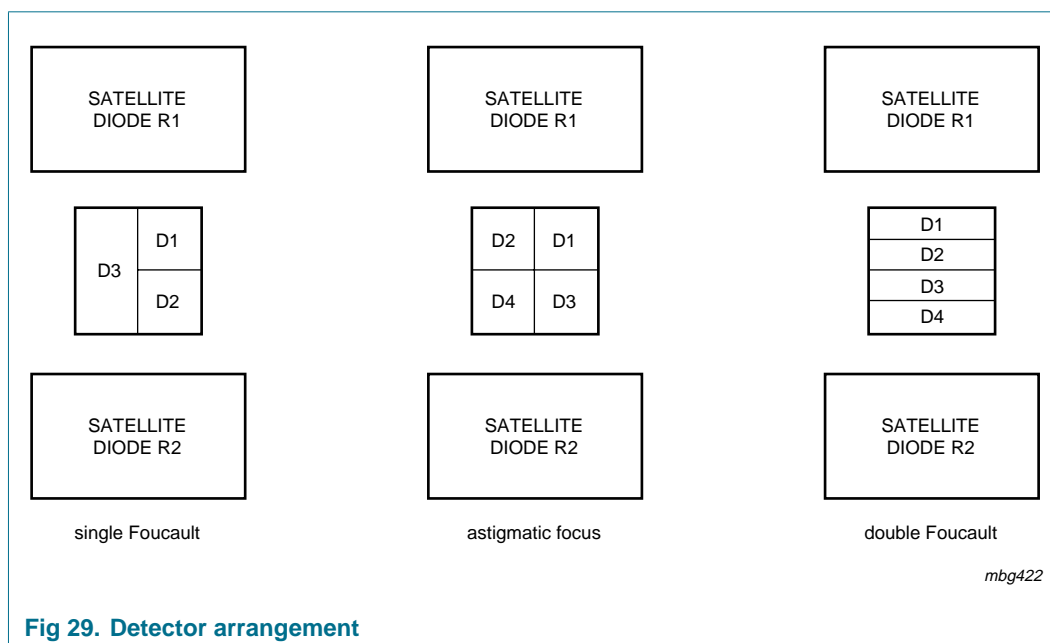

Fig 29. Detector arrangement

6.7.4 Focus servo system

6.7.4.1 Focus start-up

Five initially loaded coefficients influence the start-up behavior of the focus controller. The automatically generated triangular voltage can be influenced by 3 parameters; for height (ramp_height) and DC offset (ramp_offset) of the triangle and its steepness (ramp_incr).

For protection against false focus point detections, two parameters are available which are an absolute level on the CA signal (CA_start) and a level on the FE_n signal (FE_start). When this CA level is reached then focus has been achieved.

When focus is achieved and the level on the FE_n signal is reached, the focus PID is enabled to switch on when the next zero crossing is detected in the FE_n signal.

6.7.4.2 Focus position control loop

The focus control loop contains a digital PID controller which has 5 parameters that are available to the user. These coefficients influence the integrating (foc_int), proportional (foc_lead_length, part of foc_parm3) and differentiating (foc_pole_lead, part of foc_parm1) action of the PID and a digital low-pass filter (foc_pole_noise, part of foc_parm2) following the PID. The fifth coefficient foc_gain influences the loop gain. [Figure 30](#) shows the transfer function of the controller, and the coefficients which determine the behavior.

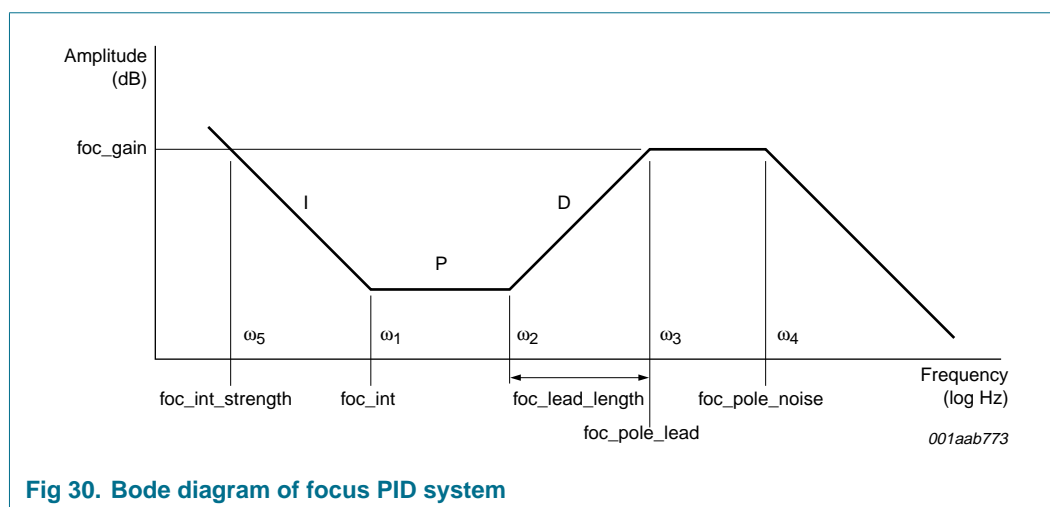

Fig 30. Bode diagram of focus PID system

A simplified block diagram of the focus PID system is given in [Figure 31](#).

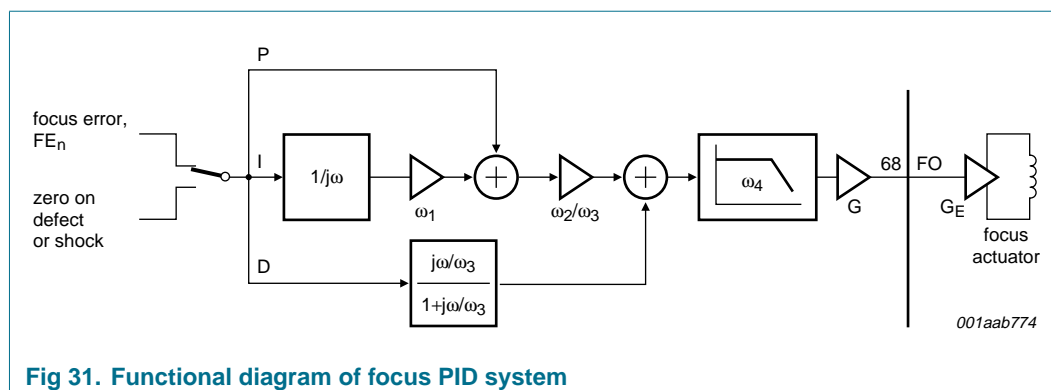

Fig 31. Functional diagram of focus PID system

By using a zero error signal, the actuator position can be held. This action is taken if a defect or shock is encountered. The PID is followed by a low-pass filter to reduce audible noise in the control loop.

The desired frequencies for the loop (ω_1 to ω_4) are used to calculate the coefficient values. Full tables are given in the *Hardware Software Interface (HSI) specification*. An explanation of the parameters in these diagrams is given in [Table 12](#).

Table 12: Focus PID parameters [1]

Parameter	Controlled by	Comment
ω_1	-	focus integrator bandwidth
ω_2	-	beginning of focus lead
ω_3	foc_parm1	foc_pole_lead; end of focus lead (differentiating part)
ω_4	foc_parm2	foc_pole_noise; low-pass function following PID
ω_3/ω_2	foc_parm3	foc_lead_length; lead length (proportional part)
$\omega_5 = (\omega_1 \cdot \omega_2 / \omega_3)$	foc_int_strength	integrator strength
G	foc_gain	focus loop gain
G_E	end stage gain	defined as peak-to-peak voltage swing over focus actuator

[1] Refer to Table 3 of the *HSI specification*.

6.7.4.3 Dropout detection

This detector can be influenced by one parameter (CA_drop). Focus will be lost and the integrator of the PID will hold if the CA signal drops below this programmable absolute CA level. When focus is lost it is assumed, initially, to be caused by a black dot.

6.7.4.4 Focus loss detection and fast restart

Whenever focus is lost for longer than approximately 3 ms, it is assumed that the focus point is lost. A fast restart procedure is initiated which is capable of restarting the focus loop within 200 ms to 300 ms depending on the programmed coefficients of the microprocessor.

6.7.4.5 Focus loop gain switching

The gain of the focus control loop (foc_gain) can be multiplied by a factor of 2 or divided by a factor of 2 during normal operation. The integrator value of the PID is corrected accordingly. The differentiating (foc_pole_lead) action of the PID can be switched at the same time as the gain switching is performed.

6.7.4.6 Focus automatic gain control loop

The loop gain of the focus control loop can be corrected automatically to eliminate tolerances in the focus loop. This gain control injects a signal into the loop which is used to correct the loop gain. Since this decreases the optimum performance, the gain control should only be activated for a short time (for example, when starting a new disc).

6.7.5 Radial servo system

6.7.5.1 Radial PID - on-track mode

When the radial servo is in on-track mode (i.e. normal play mode), a PID controller is active for the fast actuator, while the sledge is steered using either a PI or pulsed-mode system. A simplified diagram of the radial PID system is given in [Figure 32](#):

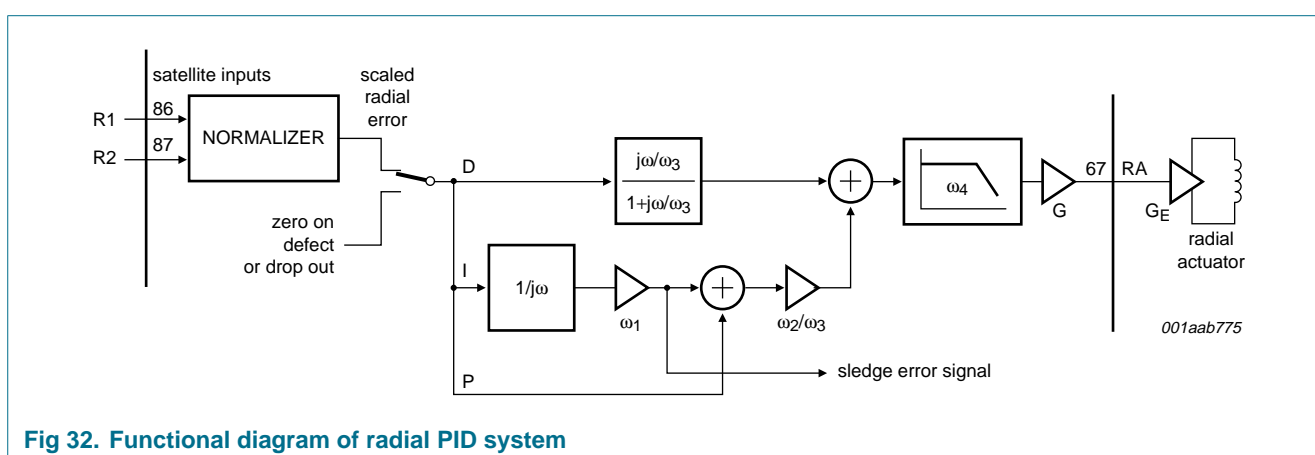

Fig 32. Functional diagram of radial PID system

An explanation of the different parameters is given below. The frequency response of this system is given in [Figure 33](#):

Table 13: Radial PID parameters [1]

Parameter	Controlled by	Comment
ω_1	-	radial integrator bandwidth
ω_2	-	beginning of radial lead
ω_3	rad_parm_play	end of radial lead (differentiating part)
ω_4	rad_pole_noise	low-pass function following PID
ω_3/ω_2	rad_length_lead	lead length (proportional part)
$\omega_5 = (\omega_1 \cdot \omega_2 / \omega_3)$	rad_int_strength	integrator strength
G	rad_gain	radial loop gain
G_E	end stage gain	defined as peak-to-peak voltage swing over radial actuator

[1] Refer to Table 2 of the *HSI specification*.

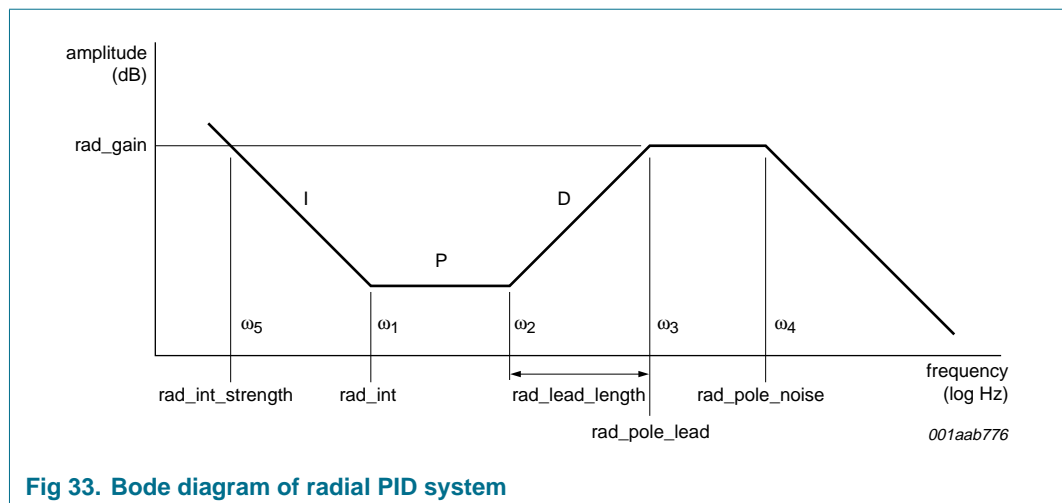

6.7.5.2 Level initialization

During start-up an automatic adjustment procedure is activated to set the values of the radial error gain (re_gain), offset (re_offset) and satellite sum gain (sum_gain) for TPI level generation. The initialization procedure runs in a radial open loop situation and is ≤ 300 ms. This start-up time period may coincide with the last part of the motor start-up time period:

- Automatic gain adjustment: as a result of this initialization the amplitude of the RE signal is adjusted to within $\pm 10\%$ around the nominal RE amplitude
- Offset adjustment: the additional offset in RE due to the limited accuracy of the start-up procedure is less than ± 50 nm
- TPI level generation: the accuracy of the initialization procedure is such that the duty factor range of TPI becomes $0.4 < \text{duty factor} < 0.6$ (default duty factor = TPI HIGH/TPI period).

6.7.5.3 Sledge control

The microprocessor can move the sledge in both directions via the steer sledge command.

6.7.5.4 Tracking control

The actuator is controlled using a PID loop filter with user defined coefficients and gain. For stable operation between the tracks, the S-curve is extended over 0.75 of the track. On request from the microprocessor, S-curve extension over 2.25 tracks is used, automatically changing to access control when exceeding those 2.25 tracks.

Both modes of S-curve extension use a track-count mechanism. In this mode, track counting results in an 'automatic return-to-zero track' to avoid major disturbances in the audio output and providing improved shock resistance. The sledge is continuously controlled, or provided with step pulses to reduce power consumption using the filtered value of the radial PID output. Alternatively, the microprocessor can read the average voltage on the radial actuator and provide the sledge with step pulses to reduce power consumption. Filter coefficients of the continuous sledge control can be preset by the user.

6.7.5.5 Access

The access procedure is divided into two different modes (see [Table 14](#)), depending on the requested jump size.

Table 14: Access types

Access type	Jump size	Access speed
Actuator jump	brake_distance [1]	decreasing velocity
Sledge jump	brake_distance - 32768	maximum power to sledge

[1] Microprocessor presettable.

The access procedure makes use of a track counting mechanism, a velocity signal based on a fixed number of tracks passed within a fixed time interval, a velocity set point calculated from the number of tracks to go and a user programmable parameter indicating the maximum sledge performance.

If the number of tracks remaining is greater than the brake_distance then the sledge jump mode should be activated or, the actuator jump should be performed. The requested jump size together with the required sledge breaking distance at maximum access speed defines the brake_distance value.

During the actuator jump mode, velocity control with a PI controller is used for the actuator. The sledge is then continuously controlled using the filtered value of the radial PID output. All filter parameters (for actuator and sledge) are user programmable.

In the sledge jump mode, maximum power (user programmable) is applied to the sledge in the correct direction while the actuator becomes idle (the contents of the actuator integrator leaks to zero just after the sledge jump mode is initiated). The actuator can be electronically damped during sledge jump. The gain of the damping loop is controlled via the hold_mult parameter.

The fast track jumping circuitry can be enabled or disabled via the xtra_preset parameter.

6.7.5.6 Radial automatic gain control loop

The loop gain of the radial control loop can be corrected automatically to eliminate tolerances in the radial loop. This gain control injects a signal into the loop which is used to correct the loop gain. Since this decreases the optimum performance, the gain control should only be activated for a short time (for example, when starting a new disc).

This gain control differs from the level initialization. The level initialization should be performed first. The disadvantage of using the level initialization without the gain control is that only tolerances from the front-end are reduced.

6.7.6 Off-track counting

The Track Position Indicator (TPI) is a flag which is used to indicate whether the radial spot is positioned on the track, with a margin of $\frac{1}{4}$ of the track-pitch. In combination with the Radial Polarity flag (RP) the relative spot position over the tracks can be determined.

These signals can have uncertainties caused by:

- Disc defects such as scratches and fingerprints
- The HF information on the disc, which is considered as noise by the detector signals.

In order to determine the spot position with sufficient accuracy, extra conditions are necessary to generate a Track Loss signal (TL) and an off-track counter value. These extra conditions influence the maximum speed and this implies that, internally, one of the following three counting states is selected:

- Protected state; used in normal play situations; a good protection against false detection caused by disc defects is important in this state
- Slow counting state; used in low velocity track jump situations; in this state a fast response is important rather than the protection against disc defects (if the phase relationship between TL and RP of $\frac{1}{2}\pi$ radians is affected too much, then the direction cannot be determined accurately)
- Fast counting state; used in high velocity track jump situations; highest obtainable velocity is the most important feature in this state.

6.7.7 Defect detection

A defect detection circuit is incorporated into the SAA7803. If a defect is detected, the radial and focus error signals may be zeroed, resulting in better playability. The defect detector can be switched off, applied only to focus control or applied to both focus and radial controls under software control (part of foc_parm1).

The defect detector has programmable set points selectable by the parameter defect_parm.

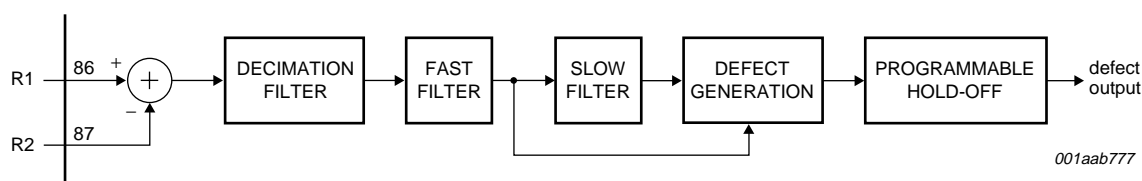

Fig 34. Defect detector diagram

6.7.8 Off-track detection

During active radial tracking, off-track detection has been released by continuously monitoring the off-track counter value. The off-track flag becomes valid whenever the off-track counter value is not equal to zero. Depending on the type of extended S-curve, the off-track counter is reset after 0.75 extend or at the original track in the 2.25 track extend mode.

6.7.9 High level features

6.7.9.1 Automatic error handling

Three watchdogs are present:

- Focus: detects focus dropout of longer than 3 ms, sets focus lost interrupt, switches off radial and sledge servos, disables drive to disc motor
- Radial play: started when radial servo is in on-track mode and a first subcode frame is found; detects when maximum time between two subcode frames exceeds the time set by playwatchtime parameter; then sets radial error interrupt, switches radial and sledge servos off, puts disc motor in jump mode

- Radial jump: active when radial servo is in long jump or short jump modes; detects when the off-track counter value decreases by less than 4 tracks between two readings (time interval set by jumpwatchtime parameter); then sets radial jump error, switches radial and sledge servos off to cancel jump.

The focus watchdog is always active, the radial watchdogs are selectable via the radcontrol parameter.

6.7.9.2 Automatic sequencers and timer interrupts

Two automatic sequencers are implemented (and must be initialized after power-on):

- Autostart sequencer: controls the start-up of focus, radial and motor
- Autostop sequencer: brakes the disc and shuts down servos.

When the automatic sequencers are not used it is possible to generate timer interrupts, defined by the time_parameter coefficient.

6.7.10 Driver interface

The control signals (pins RA, FO and SL) for the mechanism actuators are pulse density modulated. The modulating frequency can be set to either 1.0584 MHz or 2.1168 MHz; controlled via the xtra_preset parameter. An analog representation of the output signals can be achieved by connecting a first-order low-pass filter to the outputs.

During reset (i.e. pin RESET_N is held LOW) the RA, FO, and SL pins are high-impedance. At all other times, when the laser is switched off, the RA and FO pins output a 2 MHz, 50 % duty cycle signal.

6.8 Laser interface

The laser diode pre-amp function is built onto the SAA7803 and is illustrated in [Figure 35](#). The current can be regulated, up to 120 mA, in four steps ranging from 58 % up to full power. The voltage derived from the monitor diode is maintained at a steady state by the laser drive circuitry, regulating the current through the laser diode.

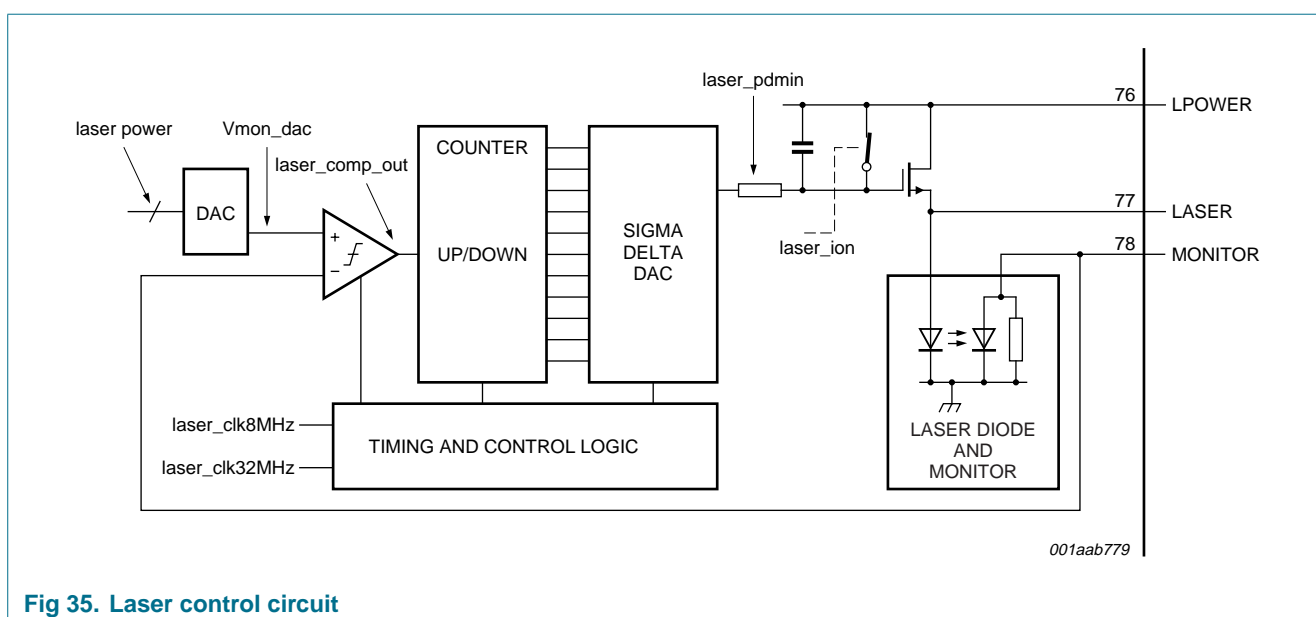

Fig 35. Laser control circuit

6.9 ARM7 system

The following diagram identifies the component parts which make up the system. The following sections give you a top-level description of the individual blocks.

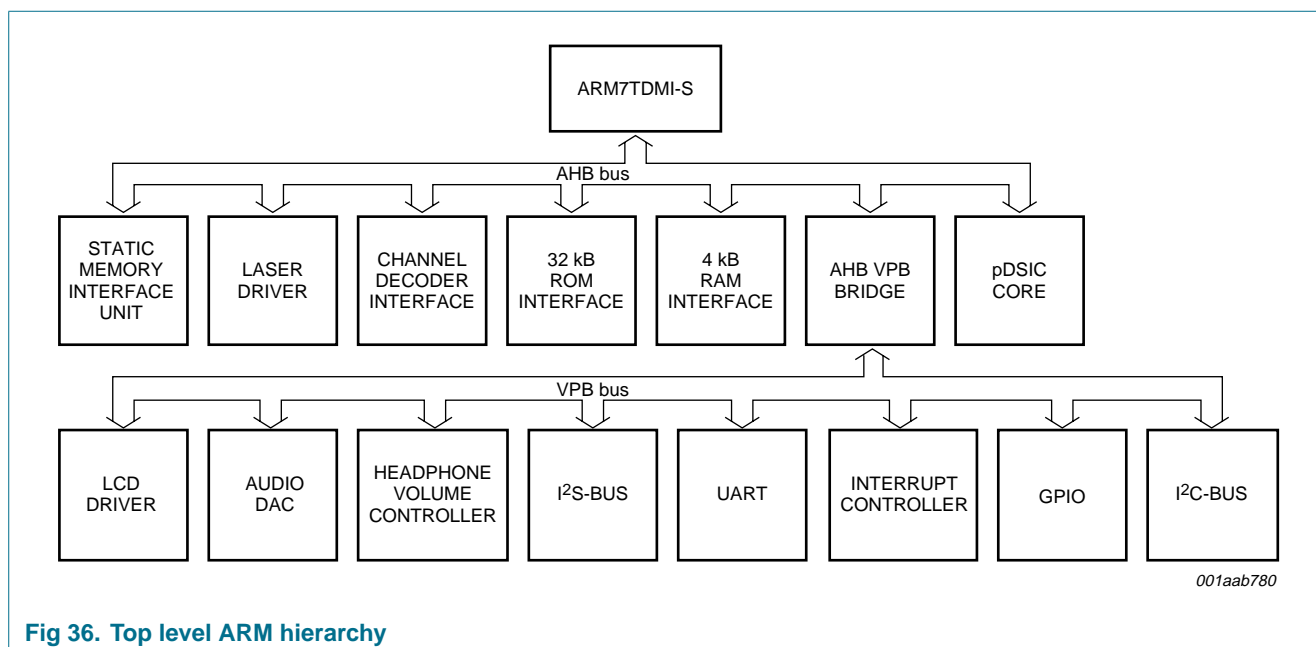

Fig 36. Top level ARM hierarchy

6.9.1 ARM7TDMI-S™ microprocessor

The ARM7TDMI-S processor is a member of the ARM family of 32-bit microprocessors. The ARM processor offers a high performance for low power consumption and low gate count. The ARM architecture is based upon Reduced Instruction Set Computer (RISC) principles. RISC provides the following key benefits:

- High instruction throughput
- Excellent real time interrupt response.

Table 15: Performance characteristics for ARM7TDMI-S

Process technology (μm)	Performance (MIPS/MHz)	Power consumption (mW/MHz)	Maximum operating frequency (MHz)	Typical operating frequency requirements for SAA7803
0.18	0.9	0.39	67	2 MHz ^[1]

[1] The frequency of operation will depend on the performance required for the SAA7803 application and the software complexity.

The ARM7TDMI-S processor has 2 instruction sets:

- The 32-bit ARM instruction set
- The 16-bit ARM Thumb instruction.

The ARM uses a 3 stage pipeline to increase the throughput of the flow of instructions to the processor. This allows several operations to operate simultaneously and the processor and memory systems to operate continuously.

The 3 stage pipelines can be defined in the following stages:

- Fetch cycle; this is used to fetch the instruction from the memory
- Decode cycle; this is used to decode the registers, used in the instructions fetched
- Execute cycle; this is used to fetch the data from register banks, the shift and ALU operations are performed and the data is written back into the memory.

The microprocessors have traditionally the same width for the instructions and data. The 32-bit architecture can be more efficient in performance and could also address a much larger address space compared to 16-bit architectures. The code density for 16-bit architecture would be much higher than 32-bit and the performance would be greater than half the 32-bit performance.

The ARM Thumb instructions concept addresses the issues when 16-bit instructions are used but the performance required is for 32-bit architecture. Therefore the aim of Thumb instruction set can be summarized as follows:

- Higher performance for 16-bit architecture if 16-bit instructions are to be used.
- The code density achieved for 16-bit instructions in a 32-bit architecture is a much more efficient usage of memory space.

6.9.2 Static Memory Interface Unit (SMIU)

The AHB SRAM controller implements an AHB slave interface to an external SRAM. This interface is only available in the development version of this device. The specification of this interface is:

- 32-bit AHB interface width
- 67 MHz maximum AHB operating frequency
- Configured for low latency
- 1 kB memory word depth
- 32-bit data.

6.9.3 ROM Interface

The ROM interface provides an interface between the onboard 4 kB SRAM memory and the ARM via the AHB bus. The specification of this interface is:

- 32-bit AHB interface width
- 67 MHz Maximum AHB operating frequency
- Configured for low latency
- 8 kB memory word depth
- 32-bit data.

The low latency architecture is optimized for low speed operation. No wait states are used and the ROM control signals are taken directly from the AHB bus. This means that the maximum frequency is likely to be limited by the speed at which the control signals arrive from the AHB master

6.9.4 RAM interface

The RAM interface provides an interface between the onboard 32 kB SRAM memory and the ARM via the AHB bus. The specification of this interface is:

- 32-bit AHB interface width
- 67 MHz maximum AHB operating frequency
- Configured for low latency
- 1 kB memory word depth
- 32-bit data.

6.9.5 I²C-bus interface

This interface can be used as an I²C-bus slave or master and is fully compliant with the I²C-bus specification. The specification of this interface is:

- Master/slave configurations
- Address 30h
- 67 MHz maximum AHB operating frequency
- 25 MHz I²C-bus operating frequency
- 4 byte RX FIFO depth
- 4 byte TX FIFO depth
- Maximum I²C-bus frequency of 400 kHz
- Compatible with 7-bit and 10-bit addressing.

6.9.6 General purpose I/Os

The GPIOs are linked to the VLSI Peripheral Bus (VPB). This interface provides individual control over each bidirectional pin. Each pin can be configured to be an input, output or bidirectional:

- 32 bidirectional I/Os.

6.9.7 Interrupt controller

- 12 dedicated internal interrupts
- 1 external interrupt which has programmable polarity
- Two interrupt types available Interrupt Request (IRQ) and Fast Interrupt Request (FIQ)
- Interrupts can be defined as IRQ or FIQ
- One of 16 priority levels can be assigned to an interrupt
- Interrupt priority threshold level
- All interrupts can be masked.

6.9.8 Universal asynchronous receiver transceiver

- 4 byte TX FIFO depth
- 4 byte RX FIFO depth
- Both RX and TX can have specific fill levels set before an interrupt is triggered
- Format of data character to be transmitted or received can be defined.

7. Code development

The SAA7803 is the firmware development platform for the SAA7804 and SAA7806 devices. [Figure 37](#) indicates the concept behind the MCM architecture. Further detail is given in the following sections.

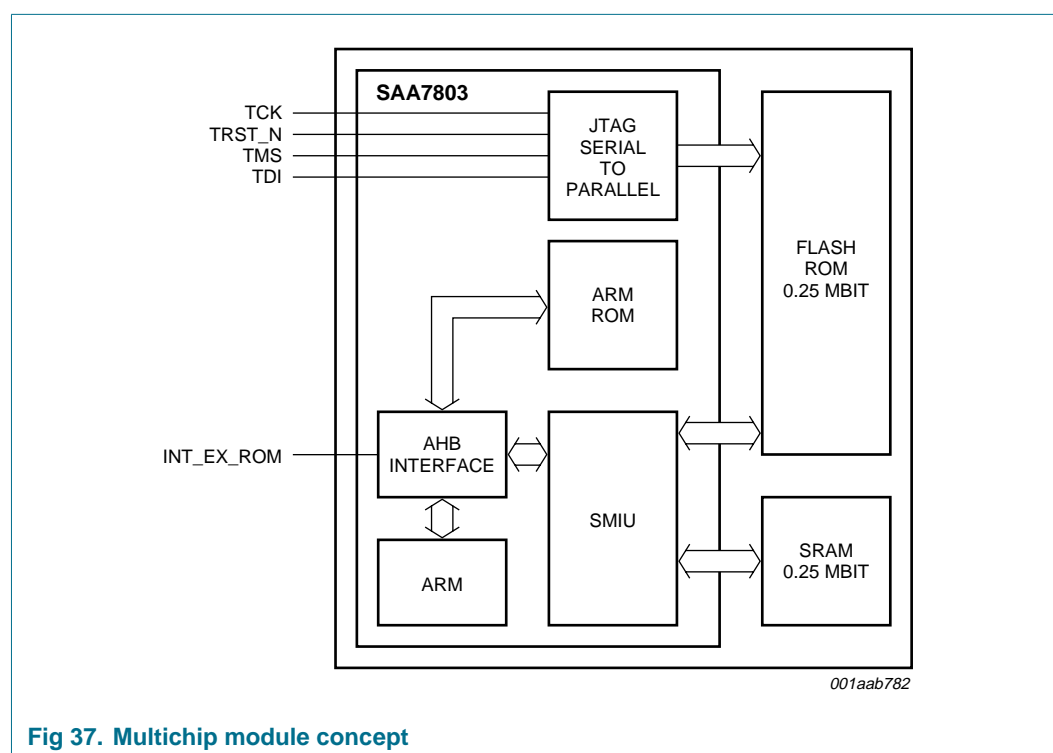

Fig 37. Multichip module concept

7.1 Memory

The development memories are organized differently from the SAA7804 and SAA7806 ARM ROM, the address range is identical i.e. 8 kB locations but the development memories are 16 bits wide rather than the 32-bit width of the ARM ROM. The SMIU compensates for this variation in location widths, avoiding the need for different address ranges between the software for the mask programmable ARM ROM and the development software. Pin INT_EX_ROM is used to select between the onboard ARM ROM memory and the MCMs external memories.

7.2 Transfer and execution of code

Code is transferred to the development memory via a JTAG interface using the protocol specified in the IEEE1149.1 standard. A detailed description of the download and transfer stages is not given since customer software has been developed to facilitate this task.

Two types of external memory are used in the MCM. Development code is initially streamed to the flash ROM and then transferred to the SRAM from where it is executed. Code is executed from the SRAM to take advantage of its superior access times.

7.3 Operating speeds

Code execution using development memory is slower than execution from the mask programmed ROM. The reasons for this are:

- The SMIU interface to development memory requires additional clock cycles to fetch instructions
- Development memory locations are only 16 bits wide whereas masked programmed ROM locations are 32 bits wide.

8. Limiting values

Table 16: Limiting values

In accordance with the Absolute Maximum Rating System (IEC 60134).

Symbol	Parameter	Conditions	Min	Max	Unit
V _{DD}	digital supply voltage		-0.5	+2.5	V
V _{DDP}	periphery supply voltage		-0.5	+3.6	V
V _{DDA}	analog supply voltage		-0.5	+3.6	V
V _{LCD}	analog LCD supply voltage		-0.5	+5.5	V
V _I	input voltage				
	analog inputs		-0.5	V _{DDA} + 0.5	V
	5 V tolerant digital inputs		[1] -0.5	5.5	V
	receiver input	transient	[2] -0.5	<tbid>	V
T _{stg}	storage temperature		-55	+125	°C
P _{tot}	total power dissipation	playing disc at 1 × with headphones enabled	-	274	mW

[1] All digital input and bidirectional pins are 5 V tolerant

[2] Maximum absolute voltage at receiver inputs during transient conditions. Transient voltage time durations are limited to t_{settle,CM} (10 ms maximum).

9. Recommended operating conditions

Table 17: Recommended operating conditions

Symbol	Parameter	Conditions	Min	Typ	Max	Unit
V _{DDD}	digital supply voltage		1.65	1.80	1.95	V
V _{DDP}	pad supply voltage		3.0	3.3	3.6	V
V _{DDA}	analog supply voltage		3.0	3.3	3.6	V
V _{LCD}	analog LCD supply voltage		4.5	5.0	5.5	V
T _{amb}	ambient temperature		-	25	-	°C

10. Characteristics

Table 18: Characteristics

V_{DDP} = V_{DDA} = 3.0 V to 3.6 V; V_{DDD} = 1.65 V to 1.95 V; T_{amb} = 25 °C; unless otherwise specified.

Symbol	Parameter	Conditions	Min	Typ	Max	Unit
Supply						
V _{DDD}	supply voltage, digital regulator		1.65	1.8	1.95	V
V _{DDP}	supply voltage, digital pads		3.0	3.3	3.6	V
V _{DDA}	supply voltage, analog		3.0	3.3	3.6	V
I _{DDD}	supply current, digital	V _{DDD} = 1.8 V	[1] 9.6	15.5	42.4	mA
I _{DDA}	supply current, analog	V _{DDA} = 3.3 V	[2] [3] 63.6	63.6	63.6	mA
I _{DDP}	supply current, peripheral	V _{DDP} = 3.3 V	[2] [4] 11.1	11.1	11.1	mA
Voltage regulator						
V _{DDD}	supply voltage, digital core		1.65	1.8	1.95	V
V _{DDD(TX)}	supply voltage, analog transmitter		1.65	1.8	1.95	V
V _{DDD(RX)}	supply voltage, analog receiver		1.65	1.8	1.95	V
Analog section (V_{DDA} = 3.3 V; V_{SSA} = 0)						
LF Path; input pins R1 and R2						
ΔV _{i(p)}	peak signal amplitude voltage range (16 steps)	unidirectional	20	-	960	mV
		bidirectional	±20	-	±960	mV
G _{tol}	gain tolerance absolute		-20	-	+20	%
ΔG _{tol(ch)}	relative gain tolerance between channels within a pair		-3	0	+3	%
ΔV _{offset(DC)}	DC offset cancellation range	relative to full-scale				
		unidirectional	-	±66	-	%
		bidirectional	-	±33	-	%
ΔG _t	cancellation accuracy	relative to full-scale	-	± 4.1	-	%
f _s	sample frequency		-	4.2336	-	MHz
f _i	input frequency (2f _s)		-	8.4672	-	MHz
B	recovered bandwidth		20	-	-	kHz
S/N	signal to noise ratio	0 kHz to 20 kHz	55	-	-	dB
THD	total harmonic distortion	0 kHz to 20 kHz	-	-	-30	dB
R _{i(v)}	input resistance in voltage mode	B = 0 kHz to 20 kHz	20	-	-	kΩ

Table 18: Characteristics ...continued $V_{DDP} = V_{DDA} = 3.0\text{ V to }3.6\text{ V}$; $V_{DDD} = 1.65\text{ V to }1.95\text{ V}$; $T_{amb} = 25\text{ }^\circ\text{C}$; unless otherwise specified.

Symbol	Parameter	Conditions	Min	Typ	Max	Unit
$R_{i(v)(tol)}$	voltage mode resistance tolerance		-30	-	+30	%
$V_{cm(min)}$	minimum input common mode range		-	1.6	-	V
V_{IO}	input offset relative to pin OPU_REF_OUT		-30	-	+30	mV
HF Path; input pins D1, D2, D3 and D4						
$V_{i(ADC)}$	6-bit ADC input range	peak-to-peak differential	1.4	1.4	1.4	V
$V_{cm(ADC)}$	6-bit ADC common mode voltage		2	-	-	V
B	bandwidth	up to $6 \times (2\text{ MHz} \times X\text{-rate})$	12	-	-	MHz
$t_{d(\phi)(f)}$	phase delay flatness	up to $6 \times (10\text{ ns}/X\text{-rate})$	-	-	1.66	ns
S/N	signal to noise ratio	100 Hz to 12 MHz	-	-	28	dB
$V_{o(p-p)}$	output swing (peak-to-peak value)	at 6 MHz	-	-	1	V
d	distortion	at 6 MHz	-	-	-35	dB
PSRR	power supply rejection		40	-	-	dB
ΔG	total gain range		2.4	-	38.4	dB
Z_i	input impedance	nominal	20	20	20	k Ω
B_{mon}	HF monitor bandwidth	-3 dB point	27	-	46	MHz
Audio DAC; Input/Output pin DAC_VREF; output pins DAC_LN, DAC_LP, DAC_RN and DAC_RP						
S/N_{AW}	A-weighted signal-to-noise ratio		-	90	-	dB
THD	total harmonic distortion	at 1 kHz	-	-	-80	dB
Audio feature; Input pins AUX_L and AUX_R						
S/N	signal to noise ratio	0 kHz to 20 kHz	55	-	-	dB
THD	total harmonic distortion	0 kHz to 20 kHz	-	-	-30	dB
Headphone buffer; input pins AUX_L and AUX_R; output pins BUF_OUT_L and BUF_OUT_R						
G	gain		-39	-	+6	dB
S/N_{AW}	A-weighted signal-to-noise ratio		90	-	-	dB
THD_{DAC}	total harmonic distortion (DAC input)	at 1 kHz	-	-	-80	dB
THD_{AUX}	total harmonic distortion (AUX input)	at 1 kHz	-	-	-80	dB
$V_{O/P(p-p)}$	O/P voltage swing (peak-to-peak value)		-	2.2	-	V
Z_i	input impedance		32	-	-	k Ω
Laser driver; input pin MONITOR						
$I_{(o)max}$	output current		120	-	-	mA
t_{su}	time for laser to reach final value		1	-	-	ms
V_{window}	voltage excursion (noise)		-1	-	+1	mV

Table 18: Characteristics ...continued
 $V_{DDP} = V_{DDA} = 3.0\text{ V to }3.6\text{ V}$; $V_{DDD} = 1.65\text{ V to }1.95\text{ V}$; $T_{amb} = 25\text{ °C}$; unless otherwise specified.

Symbol	Parameter	Conditions	Min	Typ	Max	Unit
V_O	output voltage					
		sel180 = 0	145	-	155	mV
		sel180 = 1	175	-	185	mV
Output pin: OPU_REF_OUT						
$V_{I(\text{ref})}$	band gap reference voltage		-	1.6	-	V
Oscillator						
Input pin OSCIN (external clock)						
V_I	input voltage		-	$V_{DDA}/2$	-	V
t_H	input HIGH time	relative to period	45	-	55	%
I_{LI}	input leakage current		-20	-	+20	mA
C_I	input capacitance		-	-	7	pF
Output pin: OSCOUT						
f_{OSCOUT}	oscillator frequency	crystal	[5] 8.4672	-	16.9344	MHz
		resonator	8.4672	-	16.9344	MHz
g_m	mutual conductance at start-up		17	-	-	mS
C_F	feedback capacitance		-	-	2	pF
C_O	output capacitance		-	-	7	pF
R_{bias}	internal bias resistor		-	200	-	k Ω
Pinning characteristics						
General						
I_{OZ}	3-state output leakage current	$V_O = 0\text{ V}$ or $V_O = V_{\text{DDE}}$	-	-	1	μA
I_{lu}	I/O latch-up current	$-0.5 \times V_{\text{DDP}} < V < 1.5 \times V_{\text{DDP}}$; $T_j < 125\text{ °C}$	100	-	-	mA
V_{esd}	human body model		-	-	<td>	kV
	machine model		-	-	<td>	V
Power						
I_{max}	maximum continuous current		-	-	98	mA
Digital pins						
DC specifications input and bi-directional pins						
V_{IH}	HIGH-level input voltage		2.0	-	-	V
V_{IL}	LOW-level input voltage		-	-	0.8	V
I_{IL}	LOW-level input current	$V_I = 0\text{ V}$; no pull up	-	-	1	μA
I_{IH}	HIGH-level input current	$V_I = V_{\text{DDP}}$	-	-	1	μA
<i>Parameter for pin types with hysteresis (pin types IDH and IUH)</i>						
V_{hys}	hysteresis voltage		0.4	-	-	V
<i>Parameter for pin types with pull-down (types ID and IDH)</i>						
I_{pd}	pull-down current	$V_I = V_{\text{DDP}}$	20	50	75	mA
		$V_I = 5\text{ V}$	20	50	75	mA

Table 18: Characteristics ...continued

$V_{DDP} = V_{DDA} = 3.0\text{ V to }3.6\text{ V}$; $V_{DDD} = 1.65\text{ V to }1.95\text{ V}$; $T_{amb} = 25\text{ }^{\circ}\text{C}$; unless otherwise specified.

Symbol	Parameter	Conditions	Min	Typ	Max	Unit
<i>Parameter for pin types with pull-up (types BTSU, IU and IUH)</i>						
I_{pu}	pull-up current	$V_I = 0\text{ V}$	-13	-50	-40	mA
		$V_{DDP} < V_I < 5.0\text{ V}$	0	0	0	mA
DC specifications output and bi-directional pins						
V_{OH}	HIGH-level output voltage		$V_{DDP} - 0.4$	-	-	V
V_{OL}	LOW-level output voltage		-	-	0.4	V
I_{OL}	LOW-level output current	$V_{OL} = 0.4\text{ V}$				
		5 ns slew rate output	4	-	-	mA
		12 mA output	11	-	-	mA
		27 mA output	27	-	-	mA
I_{OH}	HIGH-level output current	$V_{OH} = V_{DDP} - 0.4\text{ V}$				
		5 ns slew rate output	-5	-	-	mA
		12 mA output	-13	-	-	mA
		27 mA output	-28	-	-	mA
$I_{OH(sc)}$	HIGH-level short-circuit current	short period of time; $V_{OH} = 0\text{ V}$	-	-	-45	mA
$I_{OL(sc)}$	LOW-level short-circuit current	short period of time; $V_{OL} = V_{DDP}$	-	-	50	mA
AC specifications input pins						
t_r, t_f	rise and fall time		-	6	200	ns
AC specifications output and bi-directional pins						
<i>Parameter for pin types with slew rate limited output (types BTS, BTSU and OTS)</i>						
t_{THL}, t_{TLH}	transition times	$C_L = 30\text{ pF}$; transition times read at 10 % and 90 % of output slope; 5 ns slew rate output	-	4.0	-	ns
<i>Parameter for pin types with slew rate limited output and 12 mA source or sink current (type AOBS)</i>						
t_{THL}, t_{TLH}	transition times	$C_L = 30\text{ pF}$; transition times read at 10 % and 90 % of output slope; 5 ns slew rate output; 12 mA output	-	2.9	-	ns
<i>Parameter for pin types with 27 mA source or sink current (type OS)</i>						
t_{THL}, t_{TLH}	transition times	$C_L = 30\text{ pF}$; transition times read at 10 % and 90 % of output slope; 27 mA output	-	3.8	-	ns

[1] V_{DDD1} and V_{DDD2} .

[2] Minimum value is initial reset value; primary clock = 67 MHz; AHB and decoder = 4 MHz.
Typical and maximum value with playing CD at 1 ×; headphone buffer enabled; primary clock = 67 MHz.
For typical value AHB = 16 MHz and decoder = 4 MHz; for maximum value, AHB = 67 MHz and decoder = 4 MHz.

[3] V_{DDA1} , V_{DDA2} , V_{DDA3} and $V_{DD(DAC)}$.

[4] V_{DDP1} , V_{DDP2} and V_{DDP3} .

[5] It is recommended that the nominal running series resistance of the crystal or ceramic resonator is $\leq 60\ \Omega$.

11. Application information

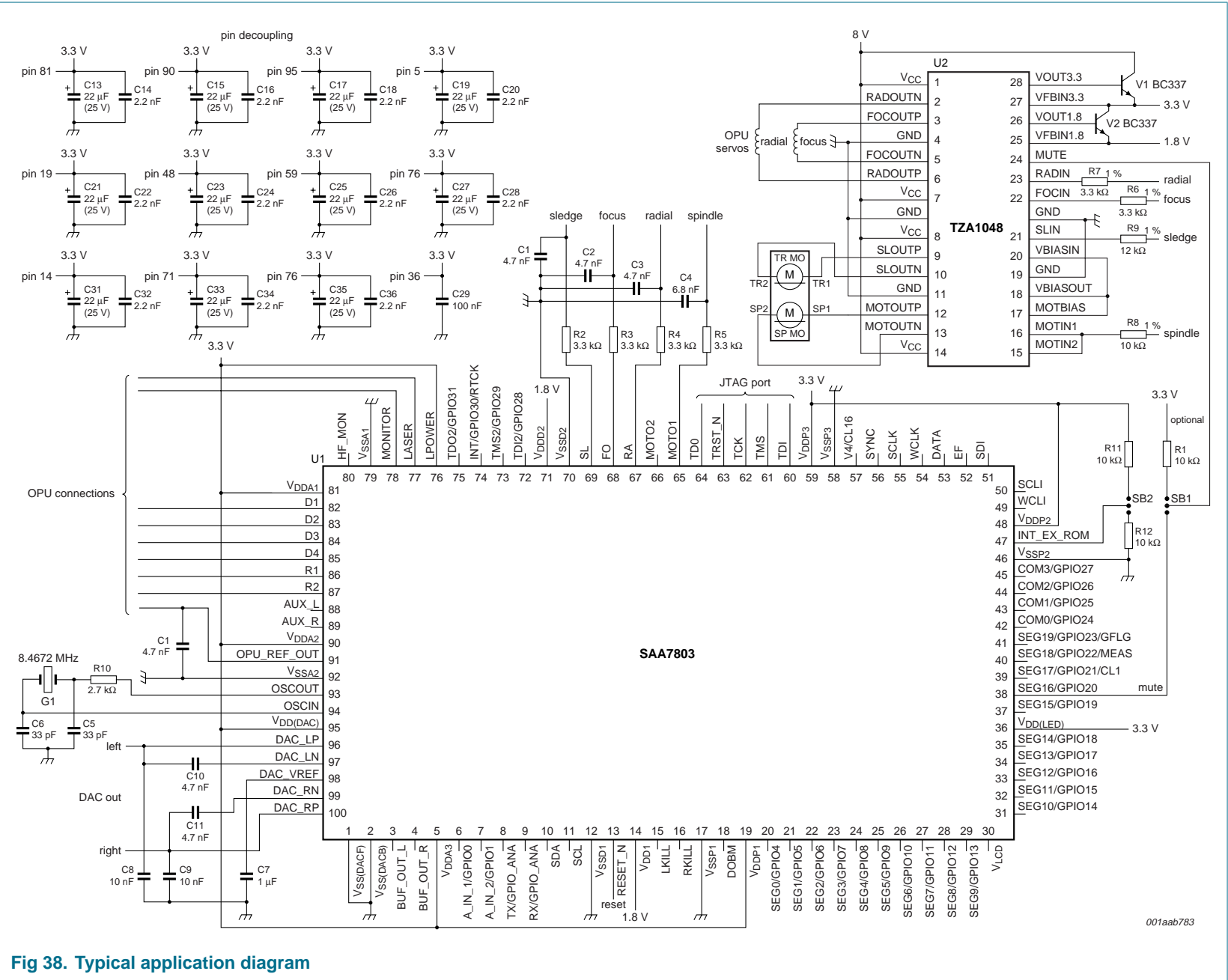

001aa783

Fig 38. Typical application diagram

12. Package outline

QFP100: plastic quad flat package; 100 leads (lead length 1.95 mm); body 14 x 20 x 2.8 mm

SOT317-2

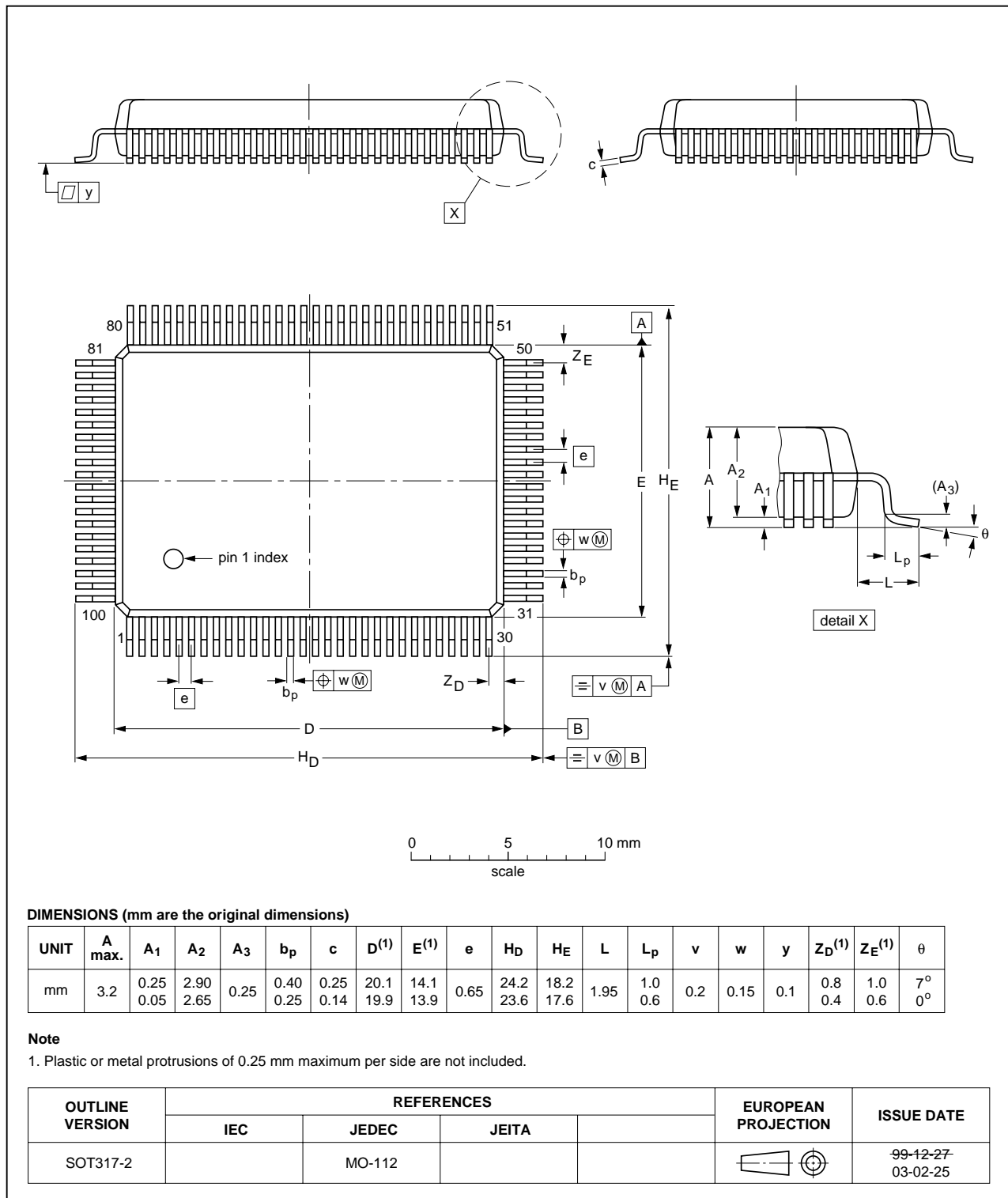

Fig 39. Package outline SOT317-2 (QFP100)

13. Soldering

13.1 Introduction to soldering surface mount packages

This text gives a very brief insight to a complex technology. A more in-depth account of soldering ICs can be found in our *Data Handbook IC26; Integrated Circuit Packages* (document order number 9398 652 90011).

There is no soldering method that is ideal for all surface mount IC packages. Wave soldering can still be used for certain surface mount ICs, but it is not suitable for fine pitch SMDs. In these situations reflow soldering is recommended.

13.2 Reflow soldering

Reflow soldering requires solder paste (a suspension of fine solder particles, flux and binding agent) to be applied to the printed-circuit board by screen printing, stencilling or pressure-syringe dispensing before package placement. Driven by legislation and environmental forces the worldwide use of lead-free solder pastes is increasing.

Several methods exist for reflowing; for example, convection or convection/infrared heating in a conveyor type oven. Throughput times (preheating, soldering and cooling) vary between 100 seconds and 200 seconds depending on heating method.

Typical reflow peak temperatures range from 215 °C to 270 °C depending on solder paste material. The top-surface temperature of the packages should preferably be kept:

- below 225 °C (SnPb process) or below 245 °C (Pb-free process)
 - for all BGA, HTSSON..T and SSOP..T packages
 - for packages with a thickness ≥ 2.5 mm
 - for packages with a thickness < 2.5 mm and a volume ≥ 350 mm³ so called thick/large packages.
- below 240 °C (SnPb process) or below 260 °C (Pb-free process) for packages with a thickness < 2.5 mm and a volume < 350 mm³ so called small/thin packages.

Moisture sensitivity precautions, as indicated on packing, must be respected at all times.

13.3 Wave soldering

Conventional single wave soldering is not recommended for surface mount devices (SMDs) or printed-circuit boards with a high component density, as solder bridging and non-wetting can present major problems.

To overcome these problems the double-wave soldering method was specifically developed.

If wave soldering is used the following conditions must be observed for optimal results:

- Use a double-wave soldering method comprising a turbulent wave with high upward pressure followed by a smooth laminar wave.
- For packages with leads on two sides and a pitch (e):
 - larger than or equal to 1.27 mm, the footprint longitudinal axis is **preferred** to be parallel to the transport direction of the printed-circuit board;

- smaller than 1.27 mm, the footprint longitudinal axis **must** be parallel to the transport direction of the printed-circuit board.

The footprint must incorporate solder thieves at the downstream end.

- For packages with leads on four sides, the footprint must be placed at a 45° angle to the transport direction of the printed-circuit board. The footprint must incorporate solder thieves downstream and at the side corners.

During placement and before soldering, the package must be fixed with a droplet of adhesive. The adhesive can be applied by screen printing, pin transfer or syringe dispensing. The package can be soldered after the adhesive is cured.

Typical dwell time of the leads in the wave ranges from 3 seconds to 4 seconds at 250 °C or 265 °C, depending on solder material applied, SnPb or Pb-free respectively.

A mildly-activated flux will eliminate the need for removal of corrosive residues in most applications.

13.4 Manual soldering

Fix the component by first soldering two diagonally-opposite end leads. Use a low voltage (24 V or less) soldering iron applied to the flat part of the lead. Contact time must be limited to 10 seconds at up to 300 °C.

When using a dedicated tool, all other leads can be soldered in one operation within 2 seconds to 5 seconds between 270 °C and 320 °C.

13.5 Package related soldering information

Table 19: Suitability of surface mount IC packages for wave and reflow soldering methods

Package [1]	Soldering method	
	Wave	Reflow [2]
BGA, HTSSON..T [3], LBGA, LFBGA, SQFP, SSOP..T [3], TFBGA, VFBGA, XSON	not suitable	suitable
DHVQFN, HBCC, HBGA, HLQFP, HSO, HSOP, HSQFP, HSSON, HTQFP, HTSSOP, HVQFN, HVSON, SMS	not suitable [4]	suitable
PLCC [5], SO, SOJ	suitable	suitable
LQFP, QFP, TQFP	not recommended [5] [6]	suitable
SSOP, TSSOP, VSO, VSSOP	not recommended [7]	suitable
CWQCCN..L [8], PMFP [9], WQCCN..L [8]	not suitable	not suitable

[1] For more detailed information on the BGA packages refer to the *(LF)BGA Application Note (AN01026)*; order a copy from your Philips Semiconductors sales office.

[2] All surface mount (SMD) packages are moisture sensitive. Depending upon the moisture content, the maximum temperature (with respect to time) and body size of the package, there is a risk that internal or external package cracks may occur due to vaporization of the moisture in them (the so called popcorn effect). For details, refer to the Drypack information in the *Data Handbook IC26; Integrated Circuit Packages; Section: Packing Methods*.

[3] These transparent plastic packages are extremely sensitive to reflow soldering conditions and must on no account be processed through more than one soldering cycle or subjected to infrared reflow soldering with peak temperature exceeding 217 °C ± 10 °C measured in the atmosphere of the reflow oven. The package body peak temperature must be kept as low as possible.

- [4] These packages are not suitable for wave soldering. On versions with the heatsink on the bottom side, the solder cannot penetrate between the printed-circuit board and the heatsink. On versions with the heatsink on the top side, the solder might be deposited on the heatsink surface.
- [5] If wave soldering is considered, then the package must be placed at a 45° angle to the solder wave direction. The package footprint must incorporate solder thieves downstream and at the side corners.
- [6] Wave soldering is suitable for LQFP, QFP and TQFP packages with a pitch (e) larger than 0.8 mm; it is definitely not suitable for packages with a pitch (e) equal to or smaller than 0.65 mm.
- [7] Wave soldering is suitable for SSOP, TSSOP, VSO and VSSOP packages with a pitch (e) equal to or larger than 0.65 mm; it is definitely not suitable for packages with a pitch (e) equal to or smaller than 0.5 mm.
- [8] Image sensor packages in principle should not be soldered. They are mounted in sockets or delivered pre-mounted on flex foil. However, the image sensor package can be mounted by the client on a flex foil by using a hot bar soldering process. The appropriate soldering profile can be provided on request.
- [9] Hot bar soldering or manual soldering is suitable for PMFP packages.

14. Abbreviations

Table 20: Abbreviations

Acronym	Description
AHB	ARM Advanced High Performance Bus
ARM	Advanced RISC Machines (32-bit microprocessor design)
ARM7TDMI-S	Specific version of ARM microprocessor used in SAA7803 (ARM7 family)
FIFO	First In, First Out
GPIO	General Purpose Input/Output
HSI	Hardware Software Interface specification
I ² C	Inter IC-bus Communication format
I ² S	Inter IC Sound format
LCD	Liquid Crystal Display
MCM	Multi Chip Module
PDSIC	Parallel Digital Servo IC (digital servo block within SAA7803)
RISC	Reduced Instruction Set Computer
Thumb	ARM 16-bit instruction set
UART	Universal Asynchronous Receiver Transmitter
VPB	VLSI Peripheral Bus

15. Revision history

Table 21: Revision history

Document ID	Release date	Data sheet status	Change notice	Doc. number	Supersedes
SAA7803_1	20050419	Objective data sheet	-	9397 750 13695	-

16. Data sheet status

Level	Data sheet status ^[1]	Product status ^[2] ^[3]	Definition
I	Objective data	Development	This data sheet contains data from the objective specification for product development. Philips Semiconductors reserves the right to change the specification in any manner without notice.
II	Preliminary data	Qualification	This data sheet contains data from the preliminary specification. Supplementary data will be published at a later date. Philips Semiconductors reserves the right to change the specification without notice, in order to improve the design and supply the best possible product.
III	Product data	Production	This data sheet contains data from the product specification. Philips Semiconductors reserves the right to make changes at any time in order to improve the design, manufacturing and supply. Relevant changes will be communicated via a Customer Product/Process Change Notification (CPCN).

[1] Please consult the most recently issued data sheet before initiating or completing a design.

[2] The product status of the device(s) described in this data sheet may have changed since this data sheet was published. The latest information is available on the Internet at URL <http://www.semiconductors.philips.com>.

[3] For data sheets describing multiple type numbers, the highest-level product status determines the data sheet status.

17. Definitions

Short-form specification — The data in a short-form specification is extracted from a full data sheet with the same type number and title. For detailed information see the relevant data sheet or data handbook.

Limiting values definition — Limiting values given are in accordance with the Absolute Maximum Rating System (IEC 60134). Stress above one or more of the limiting values may cause permanent damage to the device. These are stress ratings only and operation of the device at these or at any other conditions above those given in the Characteristics sections of the specification is not implied. Exposure to limiting values for extended periods may affect device reliability.

Application information — Applications that are described herein for any of these products are for illustrative purposes only. Philips Semiconductors make no representation or warranty that such applications will be suitable for the specified use without further testing or modification.

customers using or selling these products for use in such applications do so at their own risk and agree to fully indemnify Philips Semiconductors for any damages resulting from such application.

Right to make changes — Philips Semiconductors reserves the right to make changes in the products - including circuits, standard cells, and/or software - described or contained herein in order to improve design and/or performance. When the product is in full production (status 'Production'), relevant changes will be communicated via a Customer Product/Process Change Notification (CPCN). Philips Semiconductors assumes no responsibility or liability for the use of any of these products, conveys no license or title under any patent, copyright, or mask work right to these products, and makes no representations or warranties that these products are free from patent, copyright, or mask work right infringement, unless otherwise specified.

18. Disclaimers

Life support — These products are not designed for use in life support appliances, devices, or systems where malfunction of these products can reasonably be expected to result in personal injury. Philips Semiconductors

19. Trademarks

Thumb — is a registered trademark of ARM Limited.

ARM — is a registered trademark of ARM Limited.

ARM7TDMI-S — is a trademark of ARM Limited.

20. Contact information

For additional information, please visit: <http://www.semiconductors.philips.com>

For sales office addresses, send an email to: sales.addresses@www.semiconductors.philips.com

21. Contents

1	General description	1	6.6.7.1	Audio processing	38
2	Features	1	6.6.7.2	Interpolate and hold	38
2.1	Hardware features	1	6.6.7.3	Soft mute and error detection	39
2.2	Read formats	2	6.6.7.4	Hard mute on EBU	39
3	Ordering information	3	6.6.7.5	Silence detection and kill generation	39
4	Block diagram	3	6.6.7.6	De-emphasis filter	40
5	Pinning information	4	6.6.7.7	Upsample filter (four times)	40
5.1	Pinning	4	6.6.7.8	Data output interfaces	41
5.2	Pin description	5	6.6.7.9	I ² S-bus interface	41
6	Functional description	8	6.6.7.10	EBU interface	42
6.1	Analog data acquisition	8	6.6.7.11	Subcode interface	43
6.1.1	LF acquisition	8	6.6.8	Motor	44
6.1.2	HF acquisition	9	6.6.8.1	Frequency set point	44
6.2	Analog clock generation	10	6.6.8.2	Position error	45
6.3	General purpose analog inputs	11	6.6.8.3	Motor control loop gains (K_B , K_F and K_I)	45
6.4	Auxiliary analog inputs	11	6.6.8.4	Operation modes	45
6.5	AHB core clock generation	13	6.6.8.5	Writing and reading motor integrator value	46
6.6	Channel decoder	14	6.6.8.6	Some notes on application motor servo	46
6.6.1	Features	14	6.7	Digital Servo - PDSIC	46
6.6.2	Block diagram	15	6.7.1	PDSIC Registers and servo RAM control	46
6.6.3	Clock control	17	6.7.2	Diode signal processing	48
6.6.3.1	Signal xclk	18	6.7.3	Signal conditioning	48
6.6.3.2	Sysclock domain	18	6.7.4	Focus servo system	50
6.6.3.3	Bit clock domain	18	6.7.4.1	Focus start-up	50
6.6.3.4	EBU clock domain	18	6.7.4.2	Focus position control loop	50
6.6.4	Decoder to ARM microprocessor interface	19	6.7.4.3	Dropout detection	51
6.6.4.1	Programming interface	19	6.7.4.4	Focus loss detection and fast restart	51
6.6.4.2	Interrupt strategy	19	6.7.4.5	Focus loop gain switching	51
6.6.5	EFM bit detection and demodulation	19	6.7.4.6	Focus automatic gain control loop	52
6.6.5.1	Signal conditioning	20	6.7.5	Radial servo system	52
6.6.5.2	Bit detector	26	6.7.5.1	Radial PID - on-track mode	52
6.6.5.3	Limiting the PLL frequency range	29	6.7.5.2	Level initialization	53
6.6.5.4	Run length 2 pushback detector	30	6.7.5.3	Sledge control	53
6.6.5.5	Available signals for monitoring	30	6.7.5.4	Tracking control	53
6.6.5.6	Format of the measurement signal on MEAS pin	31	6.7.5.5	Access	54
6.6.5.7	Demodulator	32	6.7.5.6	Radial automatic gain control loop	54
6.6.5.8	EFM demodulation	32	6.7.6	Off-track counting	54
6.6.5.9	Sync detection and synchronization	32	6.7.7	Defect detection	55
6.6.5.10	Sync protection	32	6.7.8	Off-track detection	55
6.6.6	CD decoding	33	6.7.9	High level features	55
6.6.6.1	General	33	6.7.9.1	Automatic error handling	55
6.6.6.2	Q-channel subcode interface	33	6.7.9.2	Automatic sequencers and timer interrupts	56
6.6.6.3	CD-TEXT interface	34	6.7.10	Driver interface	56
6.6.6.4	Main data decoding	35	6.8	Laser interface	56
6.6.6.5	Error corrector statistics	37	6.9	ARM7 system	57
6.6.7	Audio back-end and data output interfaces	37	6.9.1	ARM7TDMI-S™ microprocessor	57
			6.9.2	Static Memory Interface Unit (SMIU)	58
			6.9.3	ROM Interface	58

continued >>

6.9.4	RAM interface	59
6.9.5	I ² C-bus interface	59
6.9.6	General purpose I/Os	59
6.9.7	Interrupt controller	59
6.9.8	Universal asynchronous receiver transceiver	60
7	Code development	60
7.1	Memory	60
7.2	Transfer and execution of code	61
7.3	Operating speeds	61
8	Limiting values	61
9	Recommended operating conditions	62
10	Characteristics	62
11	Application information	66
12	Package outline	67
13	Soldering	68
13.1	Introduction to soldering surface mount packages	68
13.2	Reflow soldering	68
13.3	Wave soldering	68
13.4	Manual soldering	69
13.5	Package related soldering information	69
14	Abbreviations	70
15	Revision history	71
16	Data sheet status	72
17	Definitions	72
18	Disclaimers	72
19	Trademarks	72
20	Contact information	72



© Koninklijke Philips Electronics N.V. 2005

All rights are reserved. Reproduction in whole or in part is prohibited without the prior written consent of the copyright owner. The information presented in this document does not form part of any quotation or contract, is believed to be accurate and reliable and may be changed without notice. No liability will be accepted by the publisher for any consequence of its use. Publication thereof does not convey nor imply any license under patent- or other industrial or intellectual property rights.

Date of release: 19 April 2005
Document number: 9397 750 13695

Published in The Netherlands

www.DataSheet4U.com