

# REVISED DATA-INTERFACE STANDARDS

Prepared by  
Dennis Morgan

Revised data-interface standards  
permit faster data rates and longer cables.  
New IC's simplify their implementation.

The purpose of this application note is to provide a brief overview, and comparison, of the communication interface standards RS232-C, RS422, RS423, RS449 and RS485 for the hardware designer. A listing of the standards' specifications, and a listing of appropriate Motorola devices are included. When more detailed information is required, the appropriate standard should be consulted.

## INTRODUCTION

EIA standard RS232-C was developed in 1969 in order to provide an industry wide standard for the interconnection of computers and computer related equipment. In that standard are defined the electrical characteristics (voltage levels, impedances, etc.), connector pin-out (25-pin connector), and a definition of the signals on the connector. Since 1969, advancements in distributed processing, as well as the growing number of intelligent peripherals are demanding more of data communications equipment, in particular longer lines and higher data rates.

For example, remote terminal clusters that interface with a host computer over a high speed data communication channel (Figure 1) have become common in systems for interactive design, and commercial applications such as banking. The distance between such terminals and a concentrator can easily be hundreds of feet, but the RS232-C standard recommends a maximum of 50 feet. And while a data link between the concentrator and modem may be only a few feet long, data rates above 20 Kilobaud present a problem for RS232-C.

Furthermore, industrial applications often demand system performance in an environment with high electrical noise levels. In such cases a balanced line reduces the effects of interference, but the RS232-C interface provides only asymmetrical (single wire) links.

For situations where RS232-C provisions are not adequate, several new specifications (RS422, RS423, and RS485) define new electrical characteristics which allow much higher performance (See Figure 2 and Table 1). RS423 provides higher data rates (to 100 Kbaud) and

longer lines (to 1200 meters), but still suffers the disadvantages of single line systems (susceptibility to noise). The need for the advantages of a balanced (2-wire) system precipitated RS422, with a resulting higher data rate (10 Mbaud). RS485 has since been developed to fill the need for two wire balanced party-line systems, involving more than one driver. The salient features of the standards are compared in Table 1.

RS449 was developed to provide a new definition for the connector (37 pins vs. 25 pins) as well as for the signal lines. This standard is intended to be used with RS422 and RS423, and can be used with RS485.

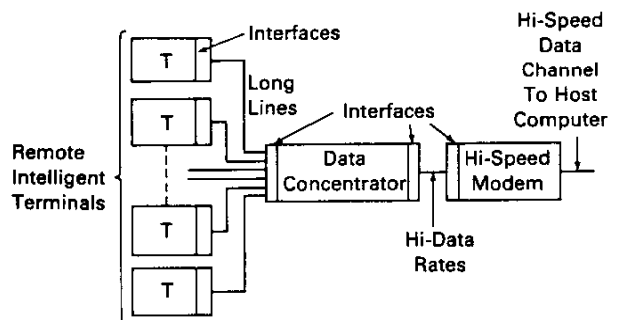
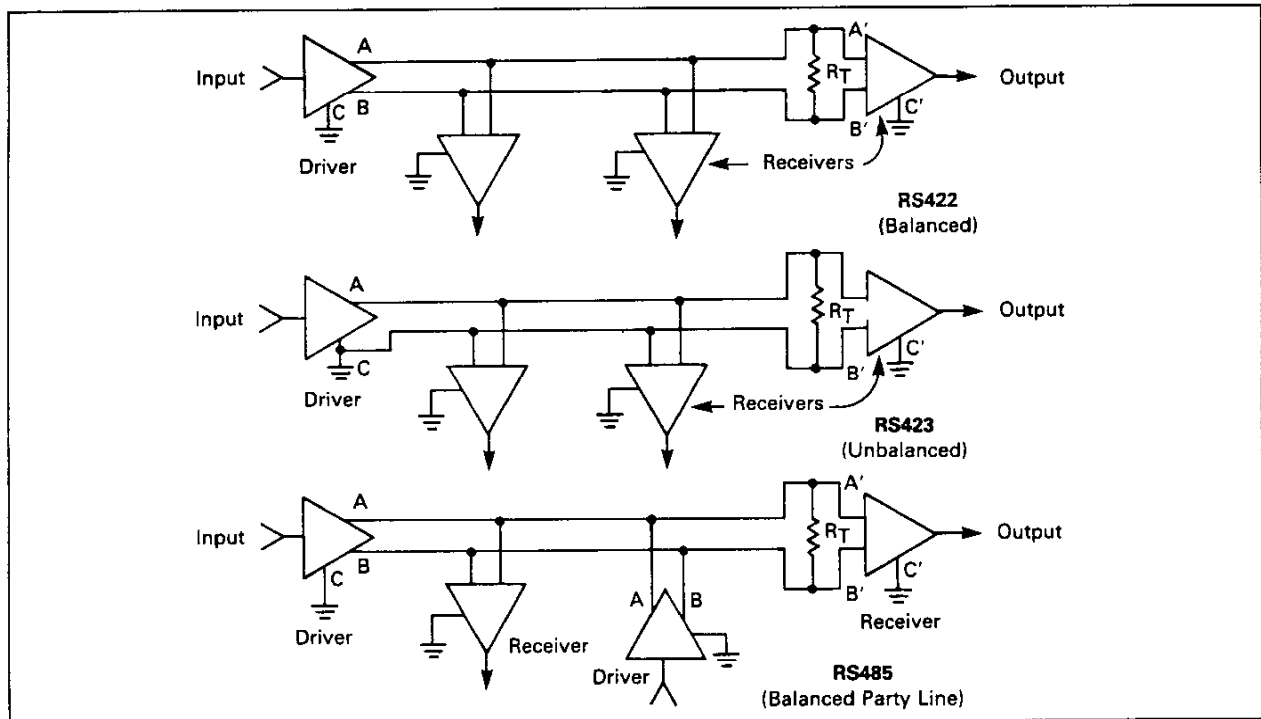

**FIGURE 1 — Remote-data-communications systems may use interface standards RS422 and 423 where lines are long, or where data rates are high.**

**TABLE 1**  
**Comparison of the Interface Standards**

Parameter	RS232-C (Aug. 1969)	RS422-A (Dec. 1978)	RS423-A (Dec. 1978)	RS485 (Apr. 1983)
<b>GENERAL</b> Type	Unbalanced single line	Balanced diff.	Unbalanced single line	Balanced diff. party line
Line length (recommended max — may be exceeded with proper design.)	50 ft. (15 m)	1200 m (4000 ft.) See Figure 3	1200 m (4000 ft.) See Figure 4	Application dependent — see text
Max. Frequency	20 Kbaud	10 Mbaud	100 Kbaud	10 Mbaud
Transition time*	$\leq 4\%$ of $\tau$ or $\leq 1.0$ ms (in undefined area between "0" and "1")	Greater of 20 ns or $\leq 0.1\tau$ (time for 10–90% of final values)	Lesser of $0.3\tau$ and 300 $\mu$ s (time for 10–90% of final values)	$\leq 0.3\tau$ (54 $\Omega$ , 50 pF load) (time for 10–90% of final values)
Max dV/dt	30 V/ $\mu$ s	See transition time	See Figure 4	See transition time
Mark (Data = 1) Space (Data = 0)	< -3.0 V > +3.0 V	A < B A > B	A = Negative A = Positive	A < B A > B
<b>DRIVERS</b> Open circuit output voltage ( $V_O$ )	$3.0 \text{ V} <  V_O  < 25 \text{ V}$	$ V_{O1}  \leq 6.0 \text{ V}$ $ V_{O2} ,  V_{O3}  \leq 6.0 \text{ V}$	$4.0 \text{ V} \leq  V_O  \leq 6.0 \text{ V}$	$1.5 \text{ V} \leq  V_O  \leq 6.0 \text{ V}$ $ V_{Oa} ,  V_{Ob}  \leq 6.0 \text{ V}$
$V_t$ (Loaded output)	$5.0 \text{ V} <  V_O  < 15 \text{ V}$ (3.0 k $\Omega$ to 7.0 k $\Omega$ load)	> 2.0 V or $\frac{1}{2}V_O <  V_t  < 6.0 \text{ V}$ 100 $\Omega$ balanced load	$ V_t  \geq 0.9 V_O $ (450 $\Omega$ load)	$1.5 \text{ V} \leq V_t \leq 5.0 \text{ V}$
Short circuit I	$\leq 500 \text{ mA}$	$\leq 150 \text{ mA}$	$\leq 150 \text{ mA}$	$\leq 250 \text{ mA}$
Output leakage ( $V_O$ applied to unpowered or Hi-Z output)	> 300 $\Omega$ , $ V_O  < 2.0 \text{ V}$	$\leq 100 \mu\text{A}$ $-0.25 \text{ V} < V_O < 6.0 \text{ V}$	< 100 $\mu\text{A}$ $ V_O  \leq 6.0 \text{ V}$	See text
Output Z	—	< 100 $\Omega$ balanced	< 50 $\Omega$	—
<b>RECEIVERS</b> Min. receiver input for proper response	> $\pm 3.0 \text{ V}$	200 mV differential	200 mV differential	200 mV differential
Input Z	3.0 k to 7.0 k $\Omega$ , 2500 pF	$\geq 4.0 \text{ k}\Omega$	$\geq 4.0 \text{ k}\Omega$	See text
Common mode voltage for balanced receiver	—	$-7.0 \text{ V} < V_{cm} < +7.0 \text{ V}$	—	$-7.0 \text{ V} \leq V_{cm} \leq +7.0 \text{ V}$

\* $\tau$  is one bit period

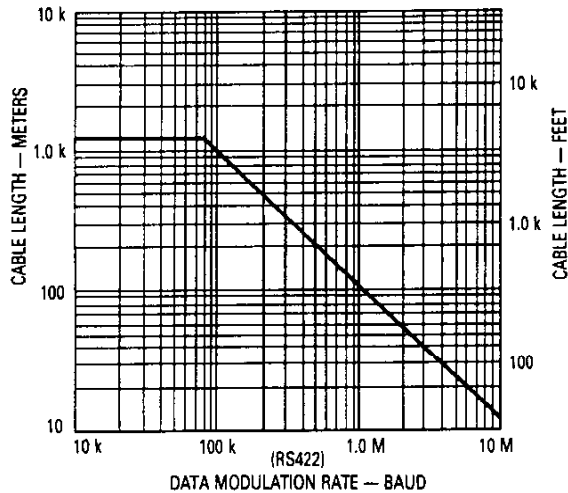

**FIGURE 2 — Basic configuration of the various newer systems are depicted. Balanced systems are typically better in electrically noisy environments.**

## HOW LONG CAN THE CABLE BE?

Maximum cable length is related to the parameters of the cable (characteristic impedance, capacitance/length, dc resistance), the driver(s) (voltage swing, output impedance, pulse shape), and receiver(s) (input impedance, sensitivity, and hysteresis), as well as to data rate and interference factors. The basic guideline is that the data pulses, sent out by a distantly located driver, altered by the characteristics of the cable, and distorted by outside influences (motors, radio transmitters, etc.), must still be recognizable by the receivers. If not, something must be changed (use of a modem, shielded cable, slower data rate, etc.).

Figure 3 relates recommended cable length to data rate for an RS422 balanced line system.



**FIGURE 3 — Permissible cable length depends on the data modulation rate.** The graph is valid for twisted-pair cable, 24 AWG, and a balanced interface.

For an RS423 unbalanced system, cable length is related to the slope ( $dV/dt$ ) of the pulse edges, according to Figure 4. The value of  $dV/dt$  to be used is that of the fastest 0.1 V increment observed in the system. While Figure 4 indicates that slower rise times allow longer cable lengths, Figure 5 indicates that slower rise times forces slower data rates, since rise and fall times are limited to 30% of bit times (maximum allowable  $t_r$  and  $t_f = 300 \mu s$ ). Thus, some systems may require a compromise between data rate and cable length. If it is desired to increase (slow down) the rise and fall times so as to be able to operate over a certain cable length, linear wave shaping of the output (available on the MC3488) is preferable over capacitive loading of the output. Capacitive loading (exponential wave shaping) reduces the allowable bit rate by a factor of 2.7 compared to linear wave shaping. For example, a 10 V signal with linear wave shape and a 10–90% rise time of  $30 \mu s$  has a  $dV/dt$  of  $0.267 V/\mu s$  ( $8.0 V/30 \mu s$ ). An exponentially shaped signal with the same maximum  $dV/dt$  has a 10–90% rise time of  $82 \mu s$ . So the data rate for linear wave shaping is 10 Kbaud, but only 3.7 Kbaud for exponential wave shaping (Figure 5).

The graphs in Figures 3, 4, and 5 are based on a 24 AWG twisted pair cable, with a capacitance of  $52.5 pF/m$  ( $16 pF/ft.$ ). Cables with lower resistance permit longer

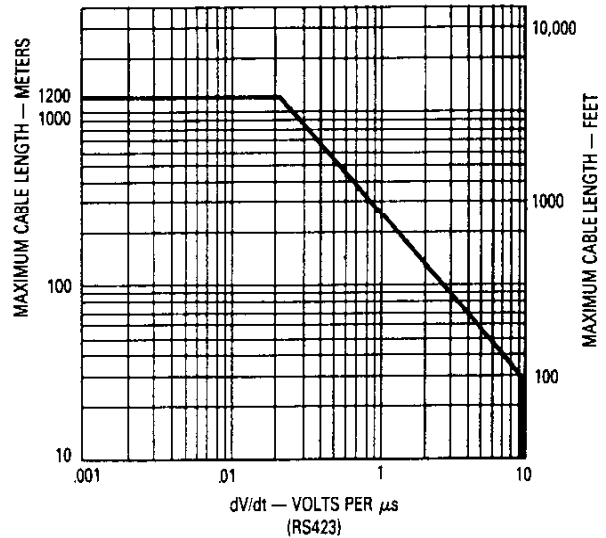

**FIGURE 4 — Pulse slopes also determine how long interconnecting cables can be.** Here,  $dV/dt$  is defined as the steepest part of the pulse slopes.

lengths, while higher capacitance shortens the permissible length. If more than 1200 meters of cable are needed, a modem may have to be inserted in the system.

The reader should be aware that the maximum cable lengths recommended in standards RS232-C, RS422, and RS423 are just that — recommendations. Longer lengths may be used if the system is properly engineered for the environment and the application.

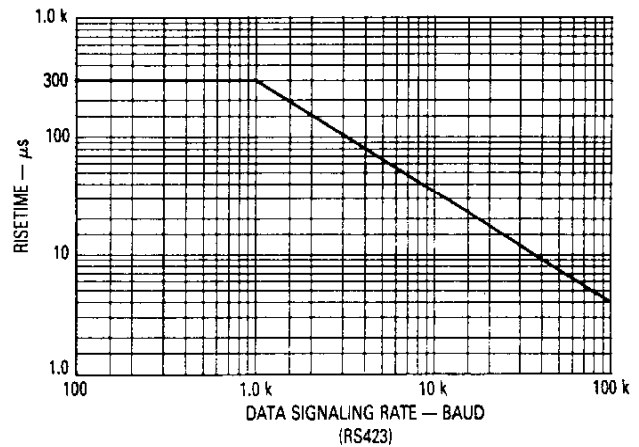

**FIGURE 5 — The maximum data-modulation rate is limited by the 10-to-90% rise time of the pulses.** If the data rate is too high, near-end crosstalk may result.

RS485 does not provide graphs (such as Figures 3 and 4) or specific numbers for maximum cable lengths, but rather provides general guidelines for selecting a cable for the particular application. The factors to be considered are:

- Data rate;
- Minimum signal voltage required at each receiver;
- Signal rise/fall time at each receiver;
- Maximum acceptable signal distortion;
- Required cable length;

The maximum allowable cable loop resistance is calculated from:

$$R_{loop} = \frac{R_{term} (1.5 V - V_{id})}{V_{id}}$$

where:  $R_{term}$  = cable terminating resistance, usually equal to the cable characteristic impedance;

$V_{id}$  = minimum signal differential voltage required at the receivers.

Using technical data on a selected cable (usually available from the cable manufacturers), the designer must determine if its dc resistance and 10–90% rise time fall within the requirements of the system. If the cable proves unsatisfactory, either a different cable must be chosen, or a slower data rate must be used.

### INPUT IMPEDANCE — SOMETHING DIFFERENT

While the receiver input impedance is defined in a fairly straightforward manner for RS232-C devices ( $3.0 k \leq Z \leq 7.0 k\Omega$ ), and RS422 and RS423 devices ( $Z \geq 4.0 k\Omega$ ), it is defined somewhat differently for RS485 devices. The load presented to the line by a receiver, or a passive generator, is defined in terms of a Unit Load (U.L.) which is defined by the graph of Figure 6. The slope of the upper and lower limits represent a dynamic impedance of  $15 k\Omega$ . The static impedance is  $12 k\Omega$  at  $+12 V$ , and  $8.75 k\Omega$  at  $-7.0 V$ . The number of unit loads a receiver (or passive generator) represents is determined by measuring the minimum static impedance within the  $-7.0 V$  to  $+12 V$  range, and comparing with Figure 6. For example, if a receiver draws  $2.0 mA$  at  $+12 V$  and  $-1.0$

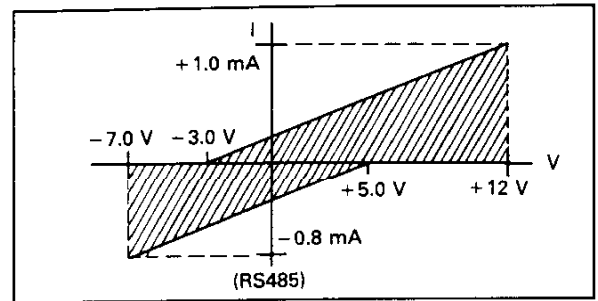

FIGURE 6 — Unit Load definition

mA at  $-7.0 V$ , it is considered to be 2 Unit Loads. If a device draws  $0.5 mA$  at  $+12 V$ , and  $-0.4 mA$  at  $-7.0 V$ , it represents 0.5 Unit Load.

The above definition permits greater flexibility for the system designer, since each load is not restricted as to its own characteristics. All that is required is that its

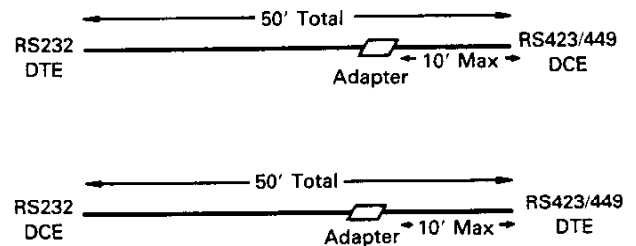

FIGURE 7 — Adapters can be used to interconnect equipment that works to different RS standards. See Figure 8.

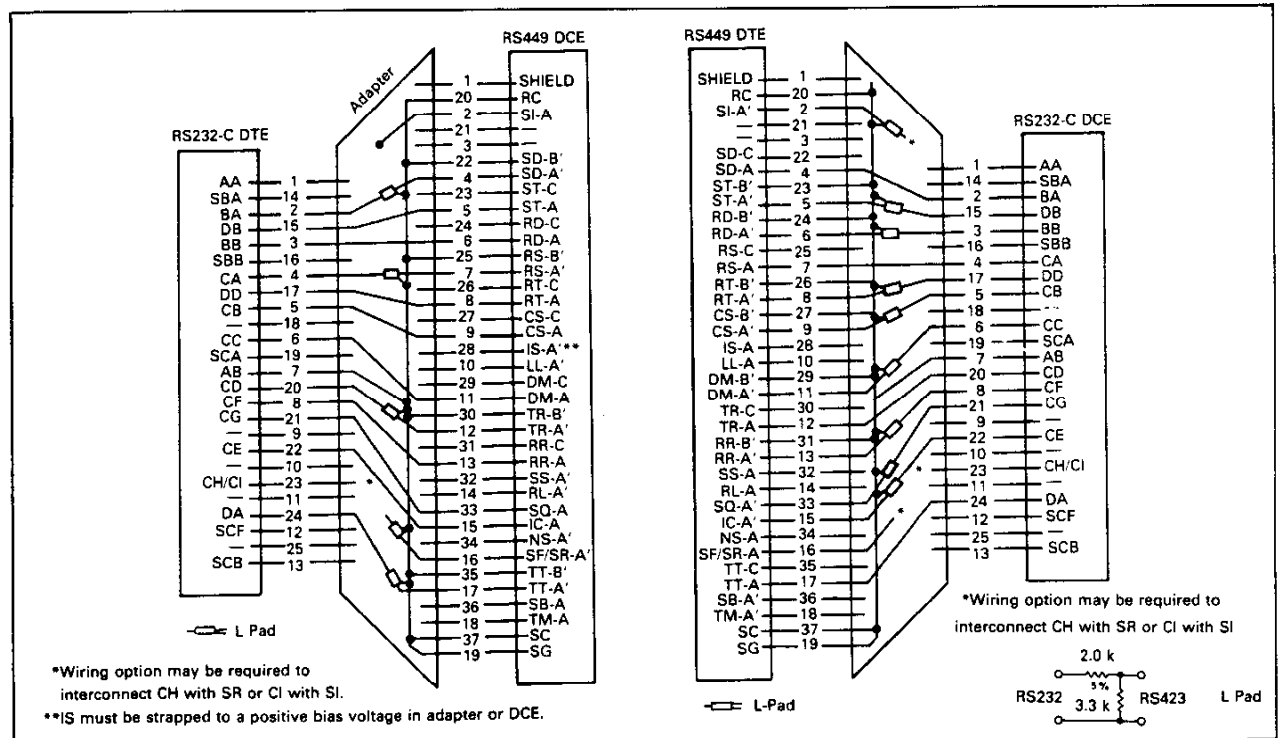

FIGURE 8 — Interconnection Between RS232-C and RS449 is in RS449 and IE Bulletin No. 12. The necessary described 37–25 pin adapters are depicted above.

unit load equivalency be known. The requirement on the drivers is that they be capable of driving 32 unit loads, plus an effective termination resistance of 60 ohms.

Note that output leakage limits are not specified for RS485 passive drivers. (A passive driver is one that is unpowered or has its output in a Hi-Z condition). The only requirement is that the unit load equivalency of a passive driver be known, so as to be included in the 32 U.L. limit mentioned above.

### RS449

RS449 was developed (in conjunction with RS422 and RS423) to provide an update of the functional description of the various interconnecting lines originally defined in RS232-C. Where RS232-C defines 20 lines associated with a 25-pin connector, RS449 defines 30 lines associated with a 37-pin connector and a 9-pin connector (the smaller connector is used only with secondary channels). RS449 does not define electrical characteristics, but states that those characteristics defined in RS422 and RS423 are to be used. The connector pin assignments are such that either a single line (RS423) or balanced line (RS422) system will be accommodated.

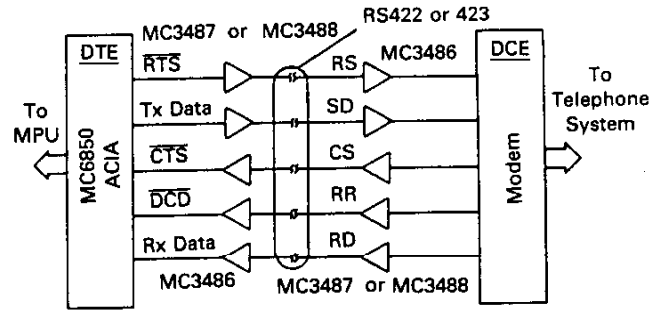

- ACIA — Asynchronous Communication Interface Adapter
- DCE — Data Communications Equipment
- DTE — Data Terminal Equipment
- RTS — Request to send — DTE asks DCE for permission to send data.
- CTS — Clear to Send — DCE grants DTE permission to send data.
- DCD — Data Carrier Detect — DCE indicates to DTE that received signal is present.
- Tx Data — Data from DTE to DCE.
- Rx Data — Data from DCE to DTE.

**FIGURE 9 — A typical application involving an ACIA and a modem.**

**TABLE 2.**  
**Equivalency Table**

RS449		RS232C	
		AA	Protective Ground
SG	Signal Ground	AB	Signal Ground
SC	Send Common		
RC	Receive Common		
IS	Terminal In Service	CE	Ring Indicator
IC	Incoming Call	CD	Data Terminal Ready
TR	Terminal Ready	CC	Data Set Ready
DM	Data Mode		
SD	Send Data	BA	Transmitted Data
RD	Receive Data	BB	Received Data
TT	Terminal Timing	DA	Transmitter Signal Element Timing (DTE Source)
ST	Send Timing	DB	Transmitter Signal Element Timing (DCE Source)
RT	Receive Timing	DD	Receiver Signal Element Timing
RS	Request To Send	CA	Request To Send
CS	Clear To Send	CB	Clear To Send
RR	Receiver Ready	CF	Received Line Signal Detector
SQ	Signal Quality	CG	Signal Quality Detector
NS	New Signal		
SF	Select Frequency	CH	Data Signal Rate Selector (DTE Source)
SR	Signaling Rate Selector	CI	Data Signal Rate Selector (DCE Source)
SI	Signaling Rate Indicator		
SSD	Secondary Send Data	SBA	Secondary Transmitted Data
SRD	Secondary Receive Data	SBB	Secondary Received Data
SRS	Secondary Request To Send	SCA	Secondary Request To Send
SCS	Secondary Clear To Send	SCB	Secondary Clear To Send
SRR	Secondary Receiver Ready	SCF	Secondary Received Line Signal Detector
LL	Local Loopback		
RL	Remote Loopback		
TM	Test Mode		
SS	Select Standby		
SB	Standby Indicator		

When a user wishes to connect a piece of equipment designed to RS232-C to one designed to RS449, an equivalency table (Table 2) indicates which lines in the two systems are to be connected to each other. The unused lines on the RS449 side are to either be left open (if an output) or tied to a voltage (if an input). EIA Industrial Bulletin No. 12 further explains the above interconnection by schematically depicting the required 37 pin-to-25 pin adapter (Figure 8), and the correct location for the adapter (Figure 7). The adapter can include "L pads" (resistor dividers) which reduce the higher RS232-C output voltages to RS423 input voltages (see Table 1). (If the MC3486 is used as the RS423 receiver, the L pad is not necessary.)

## CONCLUSION

The new RS standards, and the devices designed to perform according to the standards, have permitted an increase in cable lengths of 80 times, and a data rate increase of 500 times, while maintaining industry-wide compatibility. The cost of the newer drivers and receivers, however, is not very different from that used for RS232-C.

## ACKNOWLEDGMENT

Figures 3, 4, 5, 6, 8 and Table 2 were copied from the RS standards with permission of the Electronic Industries Association, 2001 Eye St. NW, Washington, DC, 20006.

TABLE 3. Drivers

RS Std.	Device #	Drivers per pkg.	Power Supplies	Input	Prop. Delay	Rise/Fall time	Hi-Z Output	Comments
232-C	MC1488	4	±9 to ±13.2	TTL	175/350 ns	Adjustable	No	Inverting
232-C	MC3488	2	±10.8 to ±13.2	TTL/CMOS		Adjustable	No	Inverting
422	AM26LS31	4	+5	TTL	20 ns		Yes	
422	MC3487	4	+5	TTL	20 ns	20 ns	Yes	
423	MC3488	2	±10.8 to ±13.2	TTL/CMOS		Adjustable	No	Inverting
485	SN75172	4	+5	TTL	25/65 ns	75 ns	Yes	
485	SN75174	4	+5	TTL	25/65 ns	75 ns	Yes	

TABLE 4. Receivers

RS Std.	Device #	Rcvrs. per pkg.	Power Supplies	Input Hysteresis	Prop. Delay	Output Level	Hi-Z Output	Comments
232-C	MC1489	4	+5	0.25 V-1.15 V	85 ns	TTL	No	Inverting
422/423	MC3486	4	+5	30 mV typical	35 ns	LSTTL	Yes	
422/423	AM26LS32	4	+5	30 mV typical	30 ns	LSTTL	Yes	
485	SN75173	4	+5	50 mV typical	35 ns	LSTTL	Yes	
485	SN75175	4	+5	50 mV typical	35 ns	LSTTL	Yes	

## BUILD A FAST INTERFACE — FAST

The various communications standards are easily implemented using the Motorola parts listed in Tables 3 and 4. The drivers (except MC1488) employ high impedance inputs to minimize loading, and can be connected directly to most Microprocessor I/O devices such as a PIA, ACIA, or synchronous serial data adapter. Figure 9 briefly depicts an application of this type. All drivers or receivers within an IC package operate independent of each other, except for the Hi-Z function.

Hysteresis is provided in the receivers to enhance noise immunity, since input edges may be degraded as they travel the length of the cable. This feature aids in providing clean edges at the receiver outputs.

## REFERENCES

- RS232-C, Electronic Industries Association, Wash., D.C.
- RS422, EIA, Washington, D.C.
- RS423, EIA, Washington, D.C.
- RS449, EIA, Washington, D.C.
- RS485, EIA, Washington, D.C.
- Industrial Electronic Bulletin No. 12, EIA, Wash., D.C.
- Line Driver and Receiver Considerations, AN-708A, Motorola, Inc. 1978

Copies of the EIA standards may be obtained for a small fee by writing to the following address:

Electronic Industries Association  
 Engineering Dept.  
 2001 Eye St., NW  
 Washington, D.C. 20006  
 202-457-4900

Motorola reserves the right to make changes without further notice to any products herein to improve reliability, function or design. Motorola does not assume any liability arising out of the application or use of any product or circuit described herein; neither does it convey any license under its patent rights nor the rights of others. Motorola and M are registered trademarks of Motorola, Inc. Motorola, Inc. is an Equal Employment Opportunity/Affirmative Action Employer.



**MOTOROLA Semiconductor Products Inc.**

P.O. BOX 20912 • PHOENIX, ARIZONA 85036 • A SUBSIDIARY OF MOTOROLA INC.