

# FU-632SEA-3MxxA/FU-632SEA-6MxxA

1.55  $\mu\text{m}$  EAM/DFB-LD MODULE WITH SINGLEMODE FIBER PIGTAIL(WDM)

## DESCRIPTION

Module type FU-632SEA-6MxxA is an electro-absorption modulator integrated with 1.55 $\mu\text{m}$  DFB-LD module with single mode optical fiber.

This module is suitable to a light source in 2.5Gb/s digital optical communication systems where the distance is shorter than 640km.

This module is prepared in accordance with ITU-T recommendation wavelength channel plan for Dense-WDM transmission.

## FEATURES

- Input impedance is 50 $\Omega$
- Integrated Electroabsorption Modulator(EAM)
- Distributed feedback (DFB) Laser Diode
- Emission wavelength is the 1.55 $\mu\text{m}$  band
- Single-mode optical fiber pig-tail
- Built-in optical isolator
- Built-in thermal electric cooler
- Butterfly package

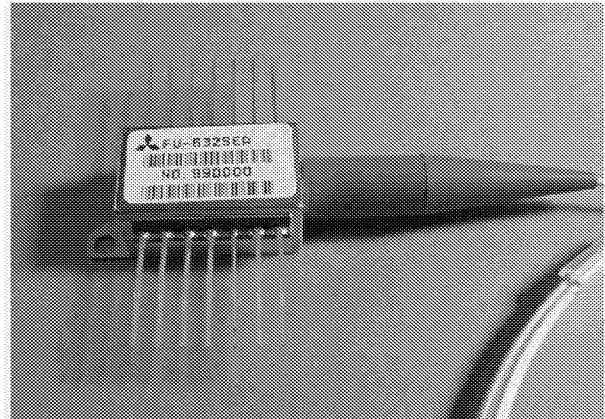

## APPLICATION

- 2.5Gbps,640ps/nm WDM application
- 2.5Gbps,1280ps/nm WDM application

## ABSOLUTE MAXIMUM RATINGS (T<sub>id</sub>=T<sub>set</sub>)

Parameter		Symbol	Conditions	Rating	Unit
Laser diode	Optical output power	Pf	CW	6	mW
	Forward current	I <sub>f</sub>	CW	200	mA
	Reverse voltage	V <sub>rl</sub>	CW	2	V
Modulator	Reverse voltage	V <sub>rm</sub>	-	5	V
	Forward voltage	V <sub>fm</sub>	-	1	V
Photodiode for monitoring	Reverse voltage	V <sub>rd</sub>	-	20	V
	Forward current	I <sub>fd</sub>	-	2	mA
Thermoelectric cooler(Note 1)	Current	I <sub>pe</sub>	-	1.5	A
	Voltage	V <sub>pe</sub>	-	3	V
Operating case temperature		T <sub>c</sub>	-	-20 to 70	°C
Storage temperature		T <sub>stg</sub>	-	-40 to 85	°C

Note 1. Even if the thermoelectric cooler(TEC) is operated within the rated conditions, uncontrolled current loading or operation without heat sink may easily damage the module by exceeding the storage temperature range. Thermistor resistance should be properly monitored by the feedback circuit during TEC operation to avoid the catastrophic damage.

# FU-632SEA-3MxxA/FU-632SEA-6MxxA

1.55 μm EAM/DFB-LD MODULE WITH SINGLEMODE FIBER PIGTAIL(WDM)

**ELECTRICAL/OPTICAL CHARACTERISTICS** (T<sub>ld</sub>=T<sub>set</sub>, T<sub>c</sub>=25°C unless otherwise noted)

Parameter	Symbol	Test Conditions	Limits			Unit
			Min.	Typ.	Max.	
Laser operating Temperature	T <sub>set</sub>	CW, I <sub>f</sub> =I <sub>op</sub>	15	-	35	°C
Threshold current	I <sub>th</sub>	CW, V <sub>m</sub> =0V	5	-	30	mA
Operating current	I <sub>op</sub>	CW, V <sub>m</sub> =0V	50	60	100	mA
Operating voltage	V <sub>op</sub>	CW, V <sub>m</sub> =0V, I <sub>f</sub> =I <sub>op</sub>	-	-	1.7	V
Input impedance	Z <sub>in</sub>	I <sub>f</sub> =I <sub>op</sub>	-	50	-	Ω
Optical output power from fiber end	P <sub>f</sub>	CW, V <sub>m</sub> =0V, I <sub>f</sub> =I <sub>op</sub>	1.2	-	-	mW
Light emission central spectral wavelength	λ <sub>c</sub>	CW, V <sub>m</sub> =0V, I <sub>f</sub> =I <sub>op</sub> , T <sub>ld</sub> =T <sub>set</sub>	see Table 1.			nm
Center wavelength drift with case temperature	Δλ <sub>c</sub> /ΔT <sub>c</sub>	CW, V <sub>m</sub> =0V, APC T <sub>ld</sub> =T <sub>set</sub> , T <sub>c</sub> =-20~70°C	-1	-	0	pm/°C
Side mode suppression ratio	S <sub>r</sub>	(Note3,5)	35	40	-	dB
Spectral width	Δλ	(Note3,5)	-	3	10	MHz
Relative intensity noise	RIN	CW, V <sub>m</sub> =0V, I <sub>f</sub> =I <sub>op</sub> , 2.5GHz	-	-155	-140	dB/Hz
Power penalty	P <sub>p</sub>	(Note4,5)	-	-	1.0	dB
		-3MxxA series @6400ps/nm				
Power penalty	P <sub>p</sub>	(Note4,5)	-	-	1.0	dB
		-6MxxA series @12800ps/nm				
Extinction ratio	Ex	(Note3,5)	11	-	-	dB
Rise/Fall time	tr/tf	(Note3,5), 10-90%	-	-	120	ps
Cutoff frequency	f <sub>c</sub>	I <sub>f</sub> =I <sub>op</sub> , V <sub>m</sub> =-1V	3.5	-	-	GHz
RF return loss	S <sub>11</sub>	I <sub>f</sub> =I <sub>op</sub> , V <sub>m</sub> =-1V, 0~2GHz	10	-	-	dB
		I <sub>f</sub> =I <sub>op</sub> , V <sub>m</sub> =-1V, 2~3GHz	7	-	-	dB
		I <sub>f</sub> =I <sub>op</sub> , V <sub>m</sub> =-1V, 3~5GHz	3	-	-	dB
Tracking error	E <sub>r</sub>	T <sub>c</sub> =-20~70°C, APC, ATC (Note6)	-	0.3	0.5	dB
Monitor current	I <sub>mon</sub>	CW, I <sub>f</sub> =I <sub>op</sub> , V <sub>m</sub> =0V	0.05	-	1.0	mA
Dark current(PD)	I <sub>d</sub>	V <sub>rd</sub> =5V, T <sub>ld</sub> =25°C	-	-	0.1	mA
Capacitance(PD)	C <sub>t</sub>	V <sub>rd</sub> =5V, T <sub>ld</sub> =25°C, f=1MHz	-	10	-	pF
Optical isolation	I <sub>so</sub>	T <sub>c</sub> =25°C	35	-	-	dB
		T <sub>c</sub> =-20~70°C	23	-	-	dB

Note 2. V<sub>m</sub> is EAM bias level at CW condition, V<sub>pp</sub> and V<sub>off</sub> are EAM amplitude and EAM high level offset voltage respectively at modulated condition.

- 2.48832Gb/s, NRZ, PRBS<sup>23</sup>-1, I<sub>f</sub>=I<sub>op</sub>, V<sub>pp</sub>=2.5V, V<sub>off</sub>=-0.2V, T<sub>ld</sub>=T<sub>set</sub>, Back to back.
- 2.48832Gb/s, NRZ, PRBS<sup>23</sup>-1, I<sub>f</sub>=I<sub>op</sub>, V<sub>pp</sub>=2.5V, V<sub>off</sub>=-0.2V, T<sub>ld</sub>=T<sub>set</sub>, dispersion=6400ps/nm for FU-632SEA-3MxxA series, or dispersion=12800ps/nm for FU-632SEA-6MxxA series.
- Optical return loss of the connectors should be greater than 40dB in order to get specified performance.
- E<sub>r</sub>=MAX{|10×log(P<sub>f</sub>(T<sub>c</sub>)/P<sub>f</sub>(25°C))|}

# FU-632SEA-3MxxA/FU-632SEA-6MxxA

1.55 μm EAM/DFB-LD MODULE WITH SINGLEMODE FIBER PIGTAIL(WDM)

## THERMAL CHARACTERISTICS (T<sub>ld</sub>=T<sub>set</sub>, T<sub>c</sub>=-20~70°C)

Parameter	Symbol	Test Conditions	Limits			Unit
			Min.	Typ.	Max.	
Thermistor resistance	R <sub>th</sub>	T <sub>ld</sub> =25°C	9.5	10	10.5	kΩ
B constant of R <sub>th</sub>	B	-	-	3950	-	K
Cooler current	I <sub>pe</sub>	I <sub>f</sub> =I <sub>op</sub> , T <sub>ld</sub> =T <sub>set</sub> , T <sub>c</sub> =70°C	-	0.7	1.2	A
Cooler voltage	V <sub>pe</sub>	I <sub>f</sub> =I <sub>op</sub> , T <sub>ld</sub> =T <sub>set</sub> , T <sub>c</sub> =70°C	-	1.7	2.5	V

## FIBER PIGTAIL SPECIFICATIONS

Parameter	Limits	Unit
Type	SM	-
Mode field diameter	9.5 ± 1	μm
Cladding diameter	125 ± 2	μm
Secondary coating outer diameter	0.9 ± 0.1	mm
Optical return loss of connector	40 (min)	dB

## DOCUMENTATION (T<sub>ld</sub>=T<sub>set</sub>)

- Fiber output power vs. Laser forward current at V<sub>m</sub>=0V, T<sub>ld</sub>=T<sub>set</sub> and T<sub>c</sub>=25°C.
- BER curves at 2.48832Gb/s modulation at T<sub>ld</sub>=T<sub>set</sub> and T<sub>c</sub>=25°C.
- Threshold current (I<sub>th</sub>) at T<sub>ld</sub>=T<sub>set</sub> and T<sub>c</sub>=25°C.
- Laser forward current (I<sub>op</sub>) at P<sub>f</sub>=1.2mW, V<sub>m</sub>=0V, T<sub>ld</sub>=T<sub>set</sub> and T<sub>c</sub>=25°C.
- Laser forward voltage (V<sub>op</sub>) at P<sub>f</sub>=1.2mW, V<sub>m</sub>=0V, T<sub>ld</sub>=T<sub>set</sub> and T<sub>c</sub>=25°C.
- Laser operating temperature (T<sub>set</sub>) at λ<sub>c</sub>. (Note 7)
- Monitor current (I<sub>mon</sub>) at P<sub>f</sub>=1.2mW, V<sub>m</sub>=0V, T<sub>ld</sub>=T<sub>set</sub> and T<sub>c</sub>=25°C.
- Thermistor resistance (R<sub>th</sub>) at λ<sub>c</sub>. (Note 7).
- Cooler current (I<sub>pe</sub>) at P<sub>f</sub>=1.2mW, V<sub>m</sub>=0V, T<sub>ld</sub>=T<sub>set</sub> and T<sub>c</sub>=70°C.
- Cooler voltage (V<sub>pe</sub>) at P<sub>f</sub>=1.2mW, V<sub>m</sub>=0V, T<sub>ld</sub>=T<sub>set</sub> and T<sub>c</sub>=70°C.

Note: 7. T<sub>set</sub> is attached as a reference data. R<sub>th</sub> should be used in order to tune the wavelength to the specified value accurately.

# FU-632SEA-3M<sub>xx</sub>A/FU-632SEA-6M<sub>xx</sub>A

1.55 μm EAM/DFB-LD MODULE WITH SINGLEMODE FIBER PIGTAIL(WDM)

**Table 1.** (All wavelengths are referred to vacuum. Tolerance is  $\lambda_c \pm 0.05\text{nm}$ .)

$\lambda_c$ (nm)	6400ps/nm	12800ps/nm
1530.33	FU-632SEA-3M11A	FU-632SEA-6M11A
1531.12	FU-632SEA-3M13A	FU-632SEA-6M13A
1531.90	FU-632SEA-3M15A	FU-632SEA-6M15A
1532.68	FU-632SEA-3M17A	FU-632SEA-6M17A
1533.47	FU-632SEA-3M19A	FU-632SEA-6M19A
1534.25	FU-632SEA-3M21A	FU-632SEA-6M21A
1535.04	FU-632SEA-3M23A	FU-632SEA-6M23A
1535.82	FU-632SEA-3M25A	FU-632SEA-6M25A
1536.61	FU-632SEA-3M27A	FU-632SEA-6M27A
1537.40	FU-632SEA-3M29A	FU-632SEA-6M29A
1538.19	FU-632SEA-3M31A	FU-632SEA-6M31A
1538.98	FU-632SEA-3M33A	FU-632SEA-6M33A
1539.77	FU-632SEA-3M35A	FU-632SEA-6M35A
1540.56	FU-632SEA-3M37A	FU-632SEA-6M37A
1541.35	FU-632SEA-3M39A	FU-632SEA-6M39A
1542.14	FU-632SEA-3M41A	FU-632SEA-6M41A
1542.94	FU-632SEA-3M43A	FU-632SEA-6M43A
1543.73	FU-632SEA-3M45A	FU-632SEA-6M45A
1544.53	FU-632SEA-3M47A	FU-632SEA-6M47A
1545.32	FU-632SEA-3M49A	FU-632SEA-6M49A
1546.12	FU-632SEA-3M51A	FU-632SEA-6M51A
1546.92	FU-632SEA-3M53A	FU-632SEA-6M53A
1547.72	FU-632SEA-3M55A	FU-632SEA-6M55A
1548.51	FU-632SEA-3M57A	FU-632SEA-6M57A
1549.32	FU-632SEA-3M59A	FU-632SEA-6M59A
1550.12	FU-632SEA-3M61A	FU-632SEA-6M61A
1550.92	FU-632SEA-3M63A	FU-632SEA-6M63A
1551.72	FU-632SEA-3M65A	FU-632SEA-6M65A
1552.52	FU-632SEA-3M67A	FU-632SEA-6M67A
1553.33	FU-632SEA-3M69A	FU-632SEA-6M69A
1554.13	FU-632SEA-3M71A	FU-632SEA-6M71A
1554.94	FU-632SEA-3M73A	FU-632SEA-6M73A
1555.75	FU-632SEA-3M75A	FU-632SEA-6M75A
1556.55	FU-632SEA-3M77A	FU-632SEA-6M77A
1557.36	FU-632SEA-3M79A	FU-632SEA-6M79A
1558.17	FU-632SEA-3M81A	FU-632SEA-6M81A
1558.98	FU-632SEA-3M83A	FU-632SEA-6M83A
1559.79	FU-632SEA-3M85A	FU-632SEA-6M85A
1560.61	FU-632SEA-3M87A	FU-632SEA-6M87A
1561.42	FU-632SEA-3M89A	FU-632SEA-6M89A
1562.23	FU-632SEA-3M91A	FU-632SEA-6M91A

# FU-632SEA-3MxxA/FU-632SEA-6MxxA

1.55 μm EAM/DFB-LD MODULE WITH SINGLEMODE FIBER PIGTAIL(WDM)

## OUTLINE DIAGRAM

(Unit: mm)

NOTES 1. TOLERANCES UNLESS NOTED±0.5

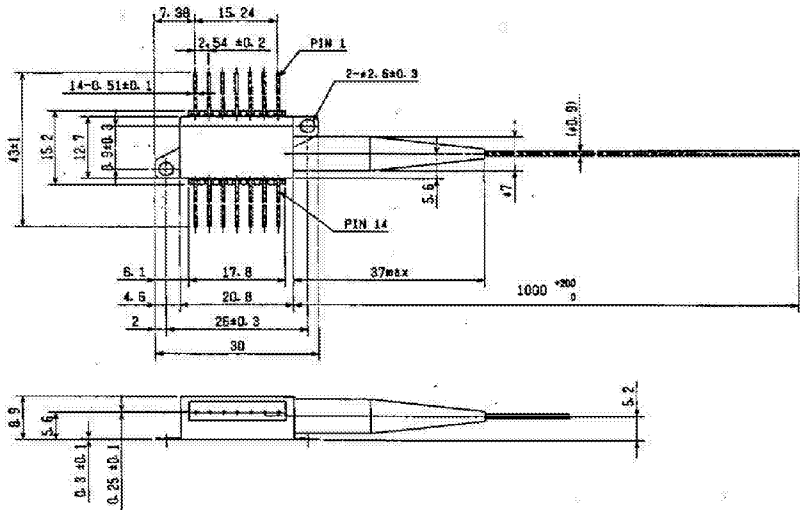

PIN	FUNCTION
1	THERMISTOR
2	THERMISTOR
3	LD BIAS
4	PD ANODE
5	PD CATHODE
6	COOLER ANODE
7	COOLER CATHODE
8	GND
9	GND
10	NC
11	LD CATHODE, GND
12	EA ANODE
13	LD CATHODE, GND
14	NC

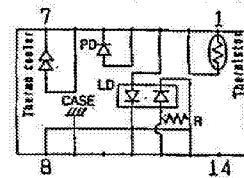

FU-632SEA-3MxxA/FU-632SEA-6MxxA