

MSM5416125A**131,072-Word × 16-Bit DYNAMIC RAM : FAST PAGE MODE TYPE****DESCRIPTION**

The OKI MSM5416125A is a 128K-word × 16-bit dynamic RAM fabricated in OKI's CMOS silicon gate technology. The MSM5416125A achieves high integration, high-speed operation, and low-power consumption due to quadruple polysilicon double metal CMOS. The MSM5416125A has conventional two $\overline{\text{CAS}}$ type 256K × 16 DRAM compatible pinout. The MSM5416125A is available in a 40-pin plastic SOJ or 44/40-pin plastic TSOP.

FEATURES

- Fast Page Mode Operation
- Byte wide control: 2 $\overline{\text{CAS}}$ control
- 131,072-word × 16-bit organization
- Pin compatible with 2 $\overline{\text{CAS}}$ type 256K × 16 DRAM
- Single 5 V power supply, ±10% tolerance
- $\overline{\text{CAS}}$ before $\overline{\text{RAS}}$ refresh, Hidden refresh, $\overline{\text{RAS}}$ only refresh capability
- Refresh: 512 cycles/8 ms
- Package options:
 - 40-pin 400 mil plastic SOJ (SOJ40-P-400-1.27) (Product : MSM5416125A-xxJS)
 - 44/40-pin 400 mil plastic TSOP (Type II) (TSOPII44/40-P-400-0.80-K) (Product:MSM5416125A-xxTS-K)
 xx indicates speed rank.

PRODUCT FAMILY

Family	Access Time (Max.)				Cycle Time (Min.)	Power Dissipation	
	t _{RAC}	t _{AA}	t _{CAC}	t _{OEA}	t _{RC}	Operating (Max.)	Standby (Max.)
MSM5416125A-40	40 ns	22 ns	14 ns	14 ns	80 ns	770 mW	11 mW
MSM5416125A-45	45 ns	24 ns	14 ns	14 ns	90 ns	715 mW	
MSM5416125A-50	50 ns	26 ns	14 ns	14 ns	100 ns	660 mW	
MSM5416125A-60	60 ns	30 ns	15 ns	15 ns	120 ns	605mW	

PIN CONFIGURATION (TOP VIEW)

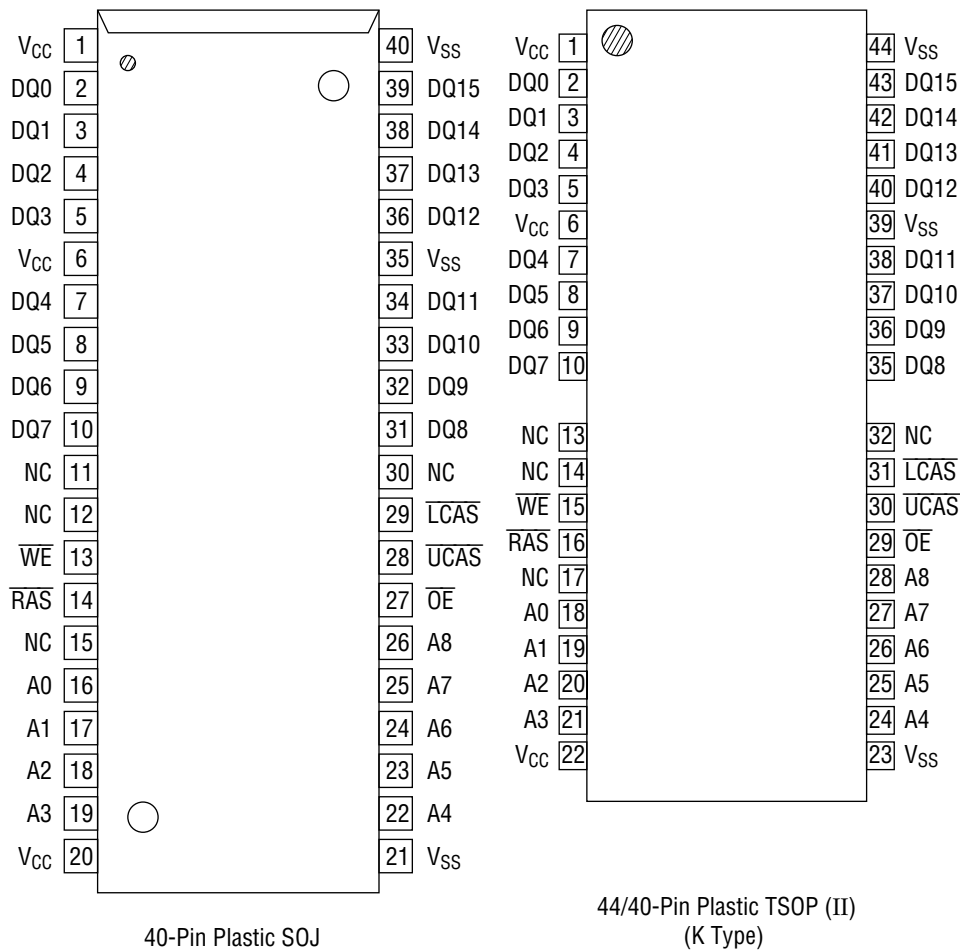

40-Pin Plastic SOJ

44/40-Pin Plastic TSOP (II)
(K Type)

Pin Name	Function
A0 - A8	Address Input Row Address : A0 - A8 Column Address : A0 - A7
RAS	Row Address Strobe
LCAS	Lower Byte Column Address Strobe
UCAS	Upper Byte Column Address Strobe
DQ0 - DQ15	Data - Input / Data - Output
WE	Write Enable
OE	Output Enable
V _{CC}	Power Supply (5 V)
V _{SS}	Ground (0 V)
NC	No Connection

Note: The same power supply voltage must be provided to every V_{CC} pin, and the same GND voltage level must be provided to every V_{SS} pin.

BLOCK DIAGRAM

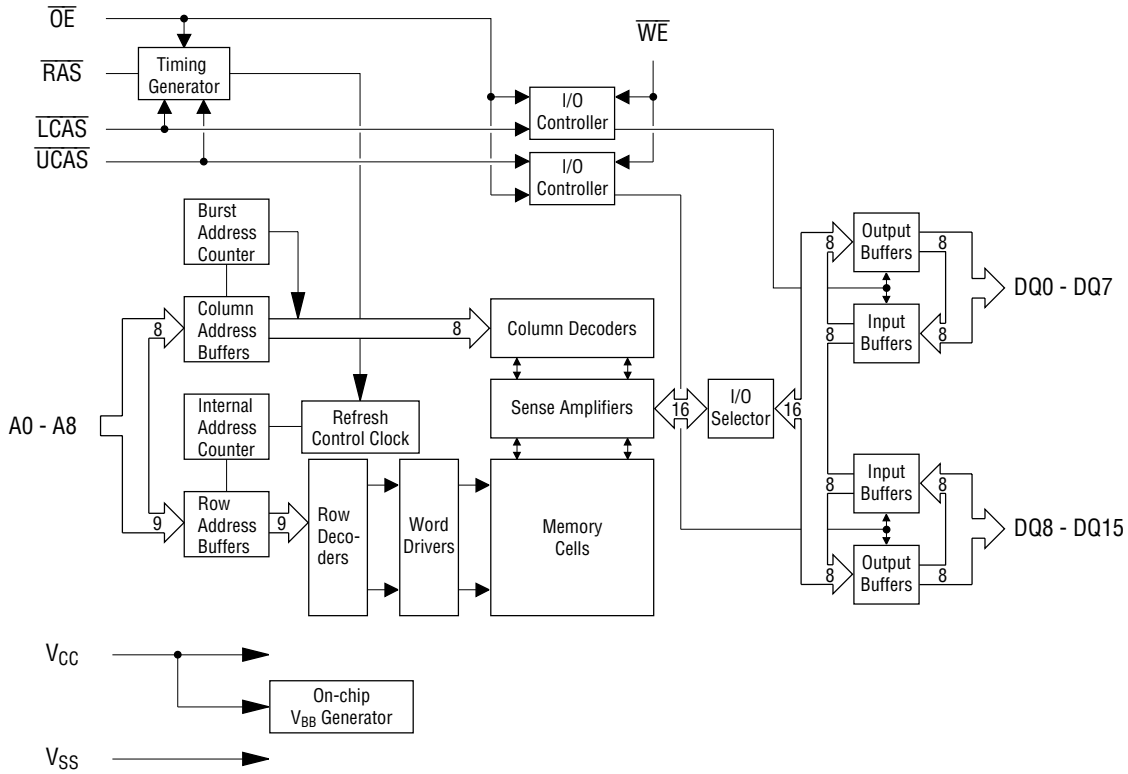

FUNCTION TABLE

Input Pin					DQ Pin		Function Mode
\overline{RAS}	\overline{LCAS}	\overline{UCAS}	\overline{WE}	\overline{OE}	DQ0 - DQ7	DQ8 - DQ15	
H	*	*	*	*	High-Z	High-Z	Standby
L	H	H	*	*	High-Z	High-Z	Refresh
L	L	H	H	L	D _{OUT}	High-Z	Lower Byte Read
L	H	L	H	L	High-Z	D _{OUT}	Upper Byte Read
L	L	L	H	L	D _{OUT}	D _{OUT}	Word Read
L	L	H	L	H	D _{IN}	Don't Care	Lower Byte Write
L	H	L	L	H	Don't Care	D _{IN}	Upper Byte Write
L	L	L	L	H	D _{IN}	D _{IN}	Word Write
L	L	L	H	H	High-Z	High-Z	—

* : "H" or "L"

ELECTRICAL CHARACTERISTICS**Absolute Maximum Ratings**

Parameter	Symbol	Condition	Rating	Unit
Voltage on Any Pin Relative to V_{SS}	V_T	$T_a = 25^\circ\text{C}$	-1.0 to 7.0	V
Short Circuit Output Current	I_{OS}	$T_a = 25^\circ\text{C}$	50	mA
Power Dissipation	P_D	$T_a = 25^\circ\text{C}$	1	W
Operating Temperature	T_{opr}	—	0 to 70	$^\circ\text{C}$
Storage Temperature	T_{stg}	—	-55 to 150	$^\circ\text{C}$

Recommended Operating Conditions $(T_a = 0^\circ\text{C to } 70^\circ\text{C})$

Parameter	Symbol	Min.	Typ.	Max.	Unit
Power Supply Voltage	V_{CC}	4.5	5.0	5.5	V
	V_{SS}	0	0	0	V
Input High Voltage	V_{IH}	2.4	—	6.5	V
Input Low Voltage	V_{IL}	-1.0	—	0.8	V

Capacitance $(V_{CC} = 5\text{ V } \pm 10\%, T_a = 25^\circ\text{C}, f = 1\text{ MHz})$

Parameter	Symbol	Typ.	Max.	Unit
Input Capacitance (A0 - A8)	C_{IN1}	—	7	pF
Input Capacitance ($\overline{\text{RAS}}$, $\overline{\text{LCAS}}$, $\overline{\text{UCAS}}$, $\overline{\text{WE}}$, $\overline{\text{OE}}$)	C_{IN2}	—	7	pF
Output Capacitance (DQ0 - DQ15)	$C_{I/O}$	—	10	pF

DC Characteristics

(V_{CC} = 5 V ±10%, Ta = 0°C to 70°C)

Parameter	Symbol	Condition	MSM5416125A -40		MSM5416125A -45		MSM5416125A -50		MSM5416125A -60		Unit	Note
			Min.	Max.	Min.	Max.	Min.	Max.	Min.	Max.		
			Output High Voltage	V _{OH}	I _{OH} = -1.0 mA	2.4	V _{CC}	2.4	V _{CC}	2.4		
Output Low Voltage	V _{OL}	I _{OL} = 1.0 mA	0	0.4	0	0.4	0	0.4	0	0.4	V	
Input Leakage Current	I _{LI}	0 V ≤ V _I ≤ 6.5 V ; All other pins not under test = 0 V	-10	10	-10	10	-10	10	-10	10	μA	
Output Leakage Current	I _{LO}	DQi Disable 0 V ≤ V _O ≤ 5.5 V	-10	10	-10	10	-10	10	-10	10	μA	
Average Power Supply Current (Operating)	I _{CC1}	$\overline{\text{RAS}}$, $\overline{\text{CAS}}$ Cycling, t _{RC} = Min.	—	140	—	130	—	120	—	110	mA	1, 2
Power Supply Current (Standby)	I _{CC2}	$\overline{\text{RAS}}$, $\overline{\text{CAS}}$ = V _{IH}	—	2	—	2	—	2	—	2	mA	1
Average Power Supply Current (RAS Only Refresh)	I _{CC3}	$\overline{\text{RAS}}$ = Cycling, $\overline{\text{CAS}}$ = V _{IH} , t _{RC} = Min.	—	140	—	130	—	120	—	110	mA	1, 2
Power Supply Current (Standby)	I _{CC5}	$\overline{\text{RAS}}$ = V _{IH} , $\overline{\text{CAS}}$ = V _{IL} , D _{out} = Enable	—	5	—	5	—	5	—	5	mA	1
Average Power Supply Current (CAS before RAS Refresh)	I _{CC6}	$\overline{\text{RAS}}$ = Cycling, $\overline{\text{CAS}}$ before $\overline{\text{RAS}}$	—	140	—	130	—	120	—	110	mA	1, 2
Average Power Supply Current (Fast Page Mode)	I _{CC7}	$\overline{\text{RAS}}$ = V _{IL} , $\overline{\text{CAS}}$ Cycling, t _{PC} = Min.	—	130	—	130	—	120	—	110	mA	1, 3

- Notes :
1. Specified values are obtained with output open.
 2. Address can be changed once or less while $\overline{\text{RAS}}$ = V_{IL}.
 3. Address can be changed once or less while $\overline{\text{CAS}}$ = V_{IH}.

AC Characteristics (1/2)

(V_{CC} = 5 V ±10%, Ta = 0°C to 70°C) Note 1, 2, 3

Parameter	Symbol	MSM5416125A -40		MSM5416125A -45		MSM5416125A -50		MSM5416125A -60		Unit	Note
		Min.	Max.	Min.	Max.	Min.	Max.	Min.	Max.		
		Random Read or Write Cycle Time	t _{RC}	80	—	90	—	100	—		
Read Modify Write Cycle Time	t _{RWC}	115	—	130	—	145	—	165	—	ns	
Fast Page Mode Cycle Time	t _{PC}	28	—	30	—	31	—	33	—	ns	
Fast Page Mode Read Modify Write Cycle Time	t _{PRWC}	60	—	60	—	65	—	80	—	ns	
Access Time from $\overline{\text{RAS}}$	t _{RAC}	—	40	—	45	—	50	—	60	ns	4, 9, 10
Access Time from $\overline{\text{CAS}}$	t _{CAC}	—	14	—	14	—	14	—	15	ns	4, 9
Access Time from Column Address	t _{AA}	—	22	—	24	—	26	—	30	ns	4, 10
Access Time from $\overline{\text{OE}}$	t _{OEa}	—	14	—	14	—	14	—	15	ns	
Access Time from $\overline{\text{CAS}}$ Precharge	t _{CPA}	—	27	—	27	—	29	—	34	ns	4, 9, 10
Output Low Impedance Time from $\overline{\text{CAS}}$	t _{CLZ}	0	—	0	—	0	—	0	—	ns	
Output Buffer Turn-off Delay Time	t _{OFF}	3	8	3	8	3	8	3	10	ns	5
$\overline{\text{OE}}$ to Data Output Buffer Turn-off Delay Time	t _{OEZ}	3	8	3	8	3	8	3	10	ns	5
Transition Time	t _T	2	35	2	35	2	35	2	35	ns	
Refresh Period	t _{REF}	—	8	—	8	—	8	—	8	ms	
$\overline{\text{RAS}}$ Precharge Time	t _{RP}	30	—	35	—	40	—	50	—	ns	
$\overline{\text{RAS}}$ Pulse Width	t _{RAS}	40	10,000	45	10,000	50	10,000	60	10,000	ns	
$\overline{\text{RAS}}$ Pulse Width (Fast Page Mode)	t _{RASP}	40	100,000	45	100,000	50	100,000	60	100,000	ns	
$\overline{\text{RAS}}$ Hold Time	t _{RSH}	14	—	14	—	14	—	15	—	ns	
$\overline{\text{RAS}}$ Hold Time referenced to $\overline{\text{OE}}$	t _{ROH}	8	—	8	—	10	—	10	—	ns	
$\overline{\text{CAS}}$ Precharge Time (Fast Page Mode)	t _{CP}	6	—	6	—	7	—	8	—	ns	14
$\overline{\text{CAS}}$ Pulse Width	t _{CAS}	14	10,000	14	10,000	14	10,000	15	10,000	ns	
$\overline{\text{CAS}}$ Hold Time	t _{CSH}	40	—	45	—	50	—	60	—	ns	
$\overline{\text{CAS}}$ to $\overline{\text{RAS}}$ Precharge Time	t _{CRP}	5	—	5	—	5	—	5	—	ns	12
$\overline{\text{RAS}}$ to $\overline{\text{CAS}}$ Delay Time	t _{RCD}	18	26	18	31	20	36	20	45	ns	9
$\overline{\text{RAS}}$ to Column Address Delay Time	t _{RAD}	13	18	13	21	15	24	15	30	ns	10
Row Address Set-up Time	t _{ASR}	0	—	0	—	0	—	0	—	ns	
Row Address Hold Time	t _{RAH}	8	—	8	—	10	—	10	—	ns	
Column Address Set-up Time	t _{ASC}	0	—	0	—	0	—	0	—	ns	11
Column Address Hold Time	t _{CAH}	6	—	6	—	8	—	10	—	ns	11
Column Address Hold Time from $\overline{\text{RAS}}$	t _{AR}	30	—	30	—	35	—	45	—	ns	
Column Address to $\overline{\text{RAS}}$ Lead Time	t _{RAL}	22	—	24	—	26	—	30	—	ns	

AC Characteristics (2/2)

(V_{CC} = 5 V ±10%, Ta = 0°C to 70°C) Note 1, 2, 3

Parameter	Symbol	MSM5416125A -40		MSM5416125A -45		MSM5416125A -50		MSM5416125A -60		Unit	Note
		Min.	Max.	Min.	Max.	Min.	Max.	Min.	Max.		
		Read Command Set-up Time	t _{RCS}	0	—	0	—	0	—		
Read Command Hold Time	t _{RCH}	0	—	0	—	0	—	0	—	ns	6, 11
Read Command Hold Time referenced to RAS	t _{RRH}	0	—	0	—	0	—	0	—	ns	6
Write Command Set-up Time	t _{WCS}	0	—	0	—	0	—	0	—	ns	8, 11
Write Command Hold Time	t _{WCH}	8	—	8	—	9	—	10	—	ns	11
Write Command Pulse Width	t _{WP}	7	—	8	—	9	—	10	—	ns	
Write Command Hold Time from RAS	t _{WCR}	30	—	30	—	35	—	45	—	ns	
OE Command Hold Time	t _{OEH}	8	—	8	—	9	—	10	—	ns	
Write Command to CAS Lead Time	t _{CWL}	7	—	8	—	9	—	12	—	ns	13
Write Command to RAS Lead Time	t _{RWL}	14	—	14	—	14	—	15	—	ns	
Data-in Set-up Time	t _{DS}	0	—	0	—	0	—	0	—	ns	7, 11
Data-in Hold Time	t _{DH}	7	—	8	—	9	—	10	—	ns	7, 11
Data-in Hold Time referenced to RAS	t _{DHR}	30	—	30	—	35	—	45	—	ns	
OE to Data-in Delay Time	t _{OED}	8	—	8	—	8	—	10	—	ns	
CAS to WE Delay Time	t _{CWD}	28	—	30	—	32	—	35	—	ns	8
Column Address to WE Delay Time	t _{AWD}	38	—	40	—	44	—	50	—	ns	8
RAS to WE Delay Time	t _{RWD}	60	—	65	—	70	—	80	—	ns	8
CAS Active Delay Time from RAS Precharge	t _{RPC}	0	—	0	—	0	—	0	—	ns	11
RAS to CAS Set-up Time (CAS before RAS)	t _{CSR}	10	—	10	—	10	—	10	—	ns	11
RAS to CAS Hold Time (CAS before RAS)	t _{CHR}	10	—	10	—	10	—	10	—	ns	12

- Notes:
1. An initial pause of 200 μ s is required after power-up, followed by any 8 $\overline{\text{RAS}}$ cycles. (Example : $\overline{\text{RAS}}$ -only-refresh) before proper device operation is achieved.
 2. The AC characteristics assume $t_T = 5$ ns.
 3. V_{IH} (Min.) and V_{IL} (Max.) are reference levels for measuring timing of input signals. Also, transition times are measured between V_{IH} and V_{IL} .
 4. This parameter is measured with a load circuit equivalent to 1 TTL load and 50 pF. Output timing reference levels are $V_{OH} = 2.0$ V and $V_{OL} = 0.8$ V.
 5. t_{OFF} (Max.) and t_{OEZ} (Max.) define the time at which the outputs achieve the open circuit condition and are not referenced to output voltage levels.
 6. t_{RCH} or t_{RRH} must be satisfied for a read cycle.
 7. These parameters are referenced to $\overline{\text{UCAS}}$, $\overline{\text{LCAS}}$, leading edge in an early write cycle, and to $\overline{\text{WE}}$ leading edge in an $\overline{\text{OE}}$ control write cycle or a read modify write cycle.
 8. t_{WCS} , t_{CWD} , t_{RWD} and t_{AWD} are not restrictive operating parameters. They are included in the data sheet as electrical characteristics only. If $t_{WCS} \geq t_{WCS}$ (Min.), the cycle is an early write cycle and the data out will remain open circuit (high impedance) throughout the entire cycle. If $t_{CWD} \geq t_{CWD}$ (Min.) , $t_{RWD} \geq t_{RWD}$ (Min.) and $t_{AWD} \geq t_{AWD}$ (Min.) , the cycle is a read modify write cycle and data out will contain data read from the selected cell; if neither of the above sets of conditions is satisfied, the condition of the data out (at access time) is indeterminate.
 9. Operation within the t_{RCD} (Max.) limit insures that t_{RAC} (Max.) can be met. t_{RCD} (Max.) is specified as a reference point only. If t_{RCD} is greater than the specified t_{RCD} (Max.) limit, then access time is controlled by t_{CAC} .
 10. Operation within the t_{RAD} (Max.) limit ensures that t_{RAC} (Max.) can be met. t_{RAD} (Max.) is specified as a reference point only: If t_{RAD} is greater than the specified t_{RAD} (Max.) limit, then access time is controlled by t_{AA} .
 11. These parameters are determined by the falling edge of $\overline{\text{UCAS}}$ or $\overline{\text{LCAS}}$, whichever is earlier.
 12. These parameters are determined by the rising edge of $\overline{\text{UCAS}}$ or $\overline{\text{LCAS}}$, whichever is later.
 13. t_{CWL} should be satisfied by both $\overline{\text{UCAS}}$ and $\overline{\text{LCAS}}$.
 14. t_{CP} is determined by the time both $\overline{\text{UCAS}}$ and $\overline{\text{LCAS}}$ are high.
 15. Input levels at the AC testing are 3.0 V/0.5 V.

TIMING WAVEFORM

Read Cycle

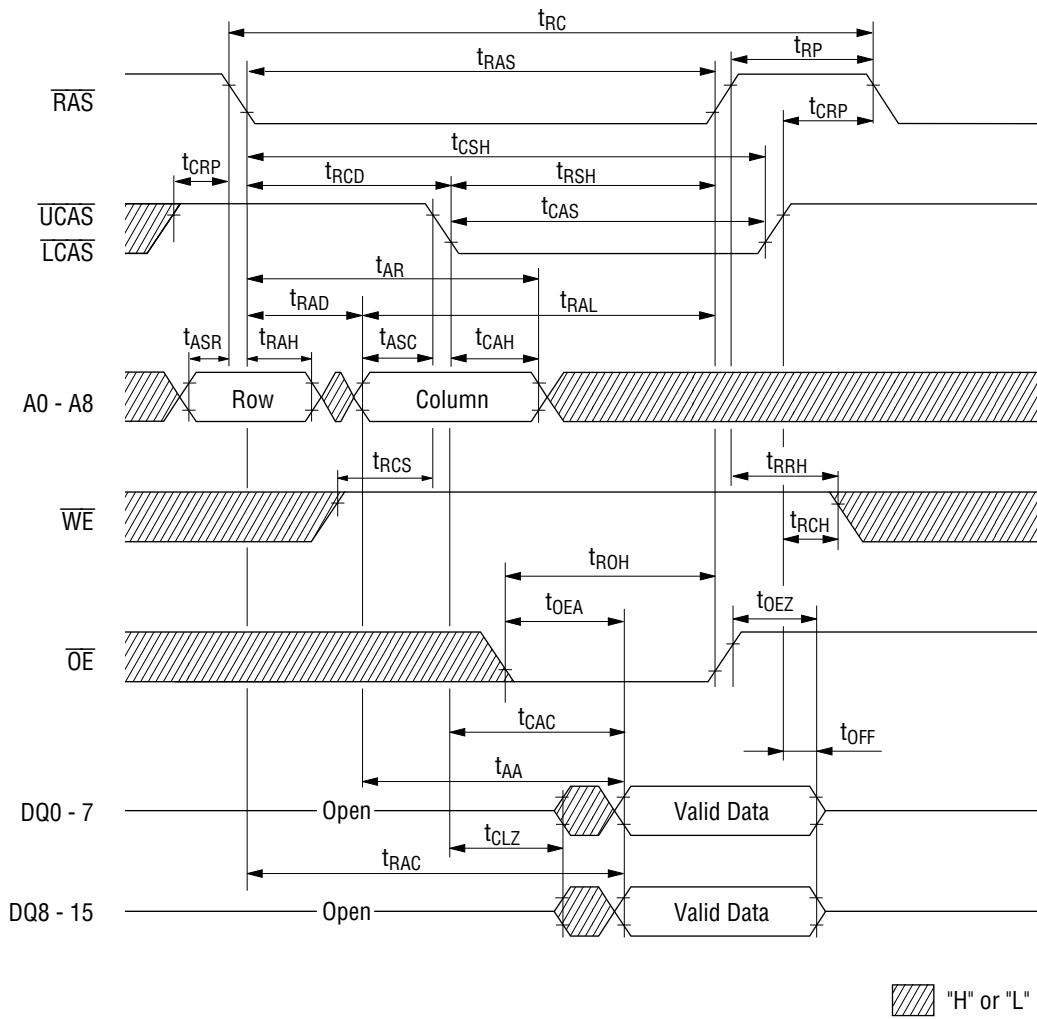

Early Write Cycle ($\overline{\text{LCAS}}$ and $\overline{\text{UCAS}}$ Active)

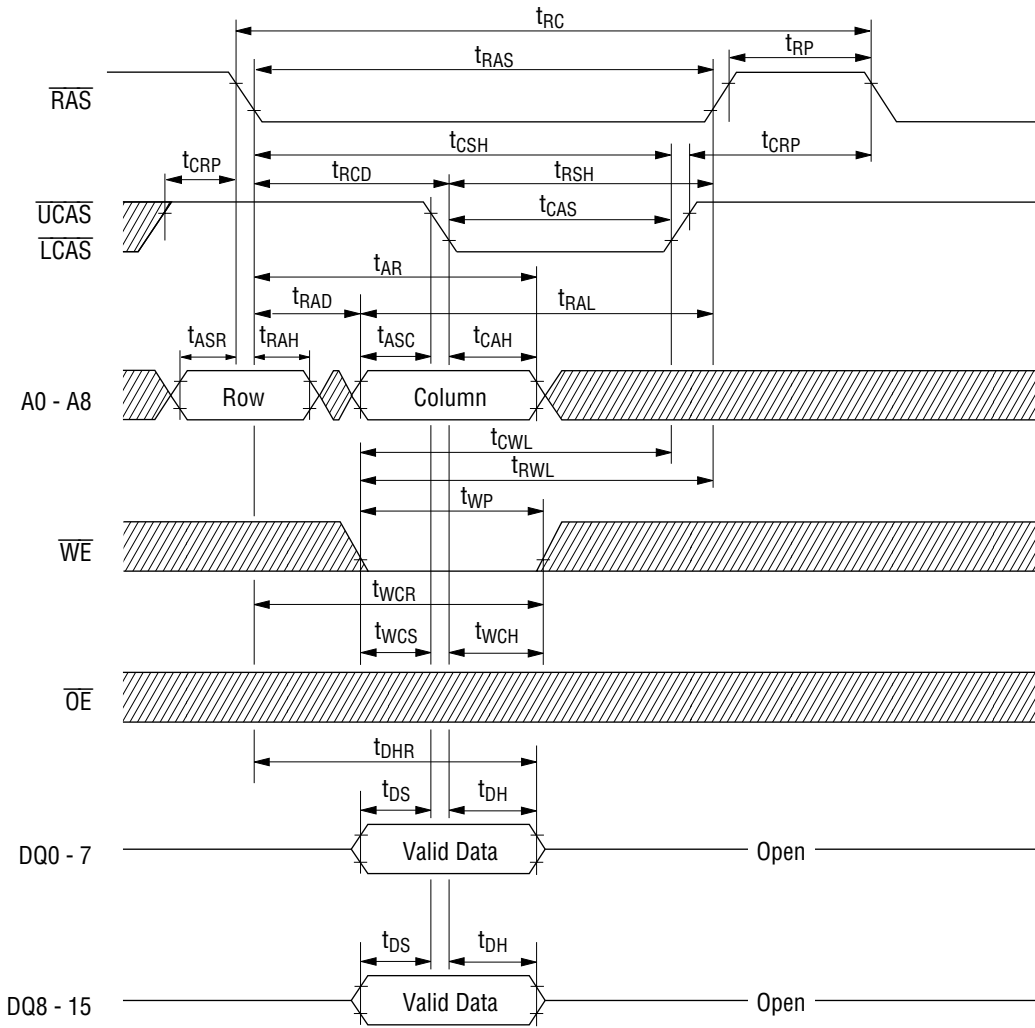

 "H" or "L"

Late Write Cycle ($\overline{\text{LCAS}}$ and $\overline{\text{UCAS}}$ Active)

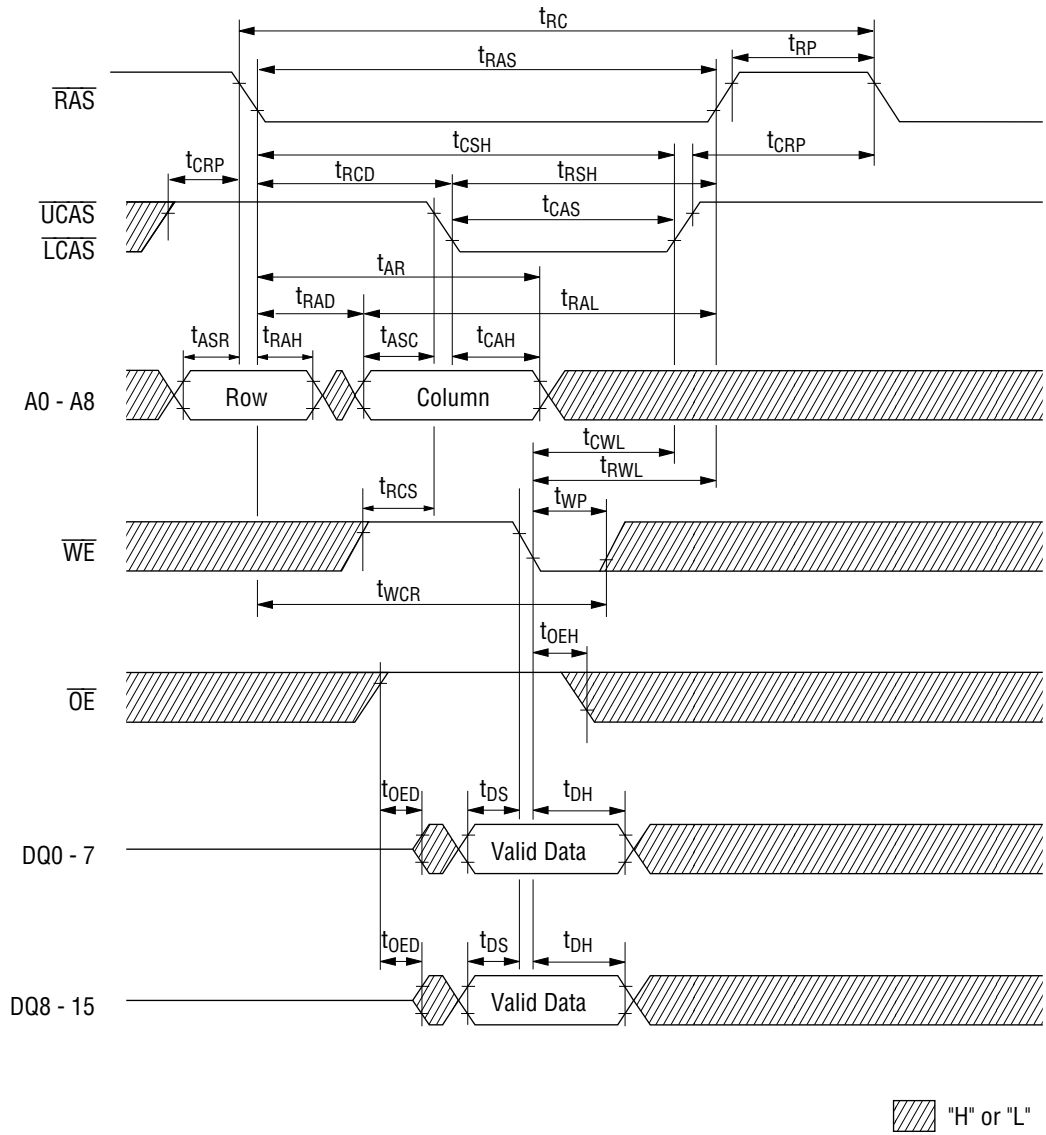

Read Modify Write Cycle ($\overline{\text{LCAS}}$ and $\overline{\text{UCAS}}$ Active)

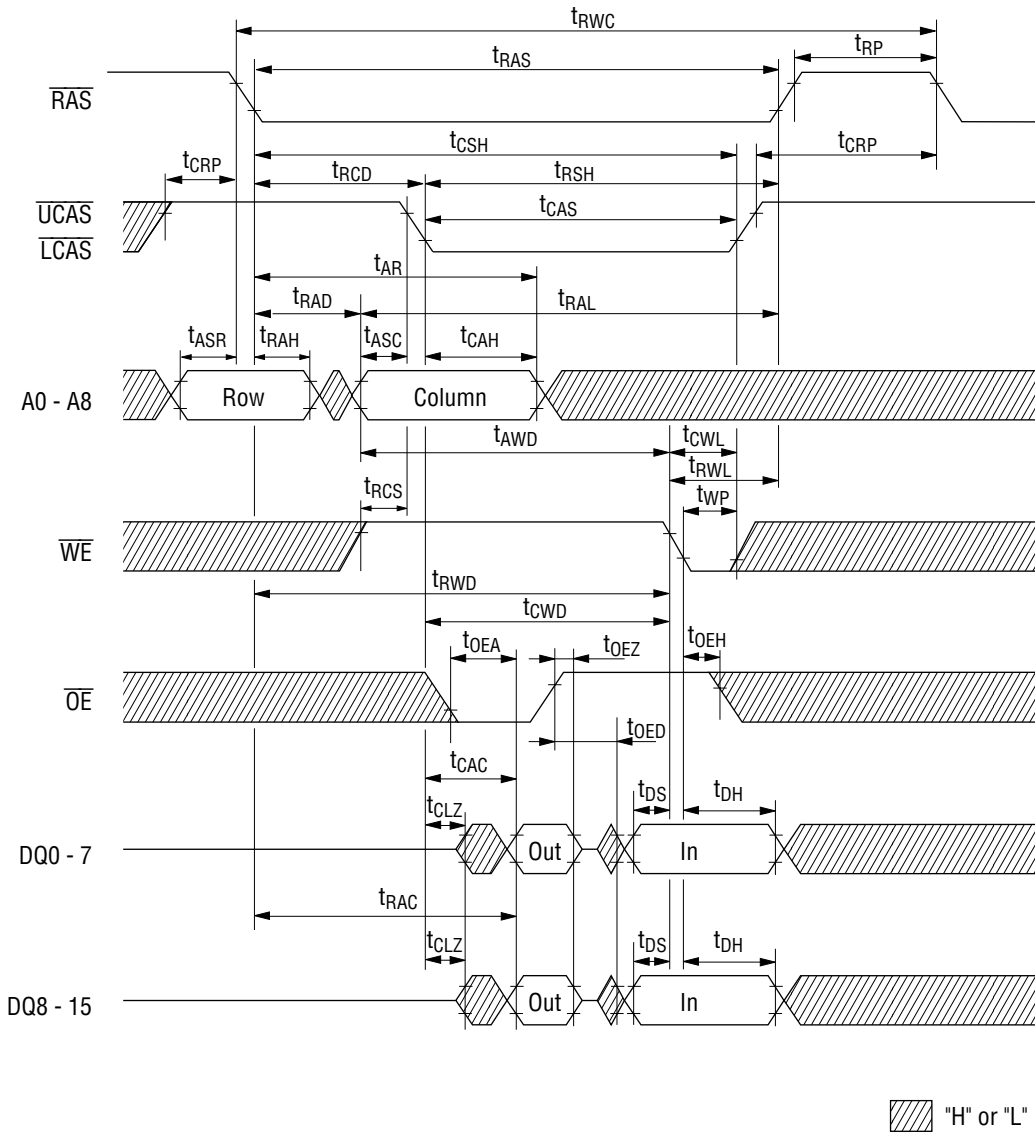

Fast Page Mode Early Write Cycle

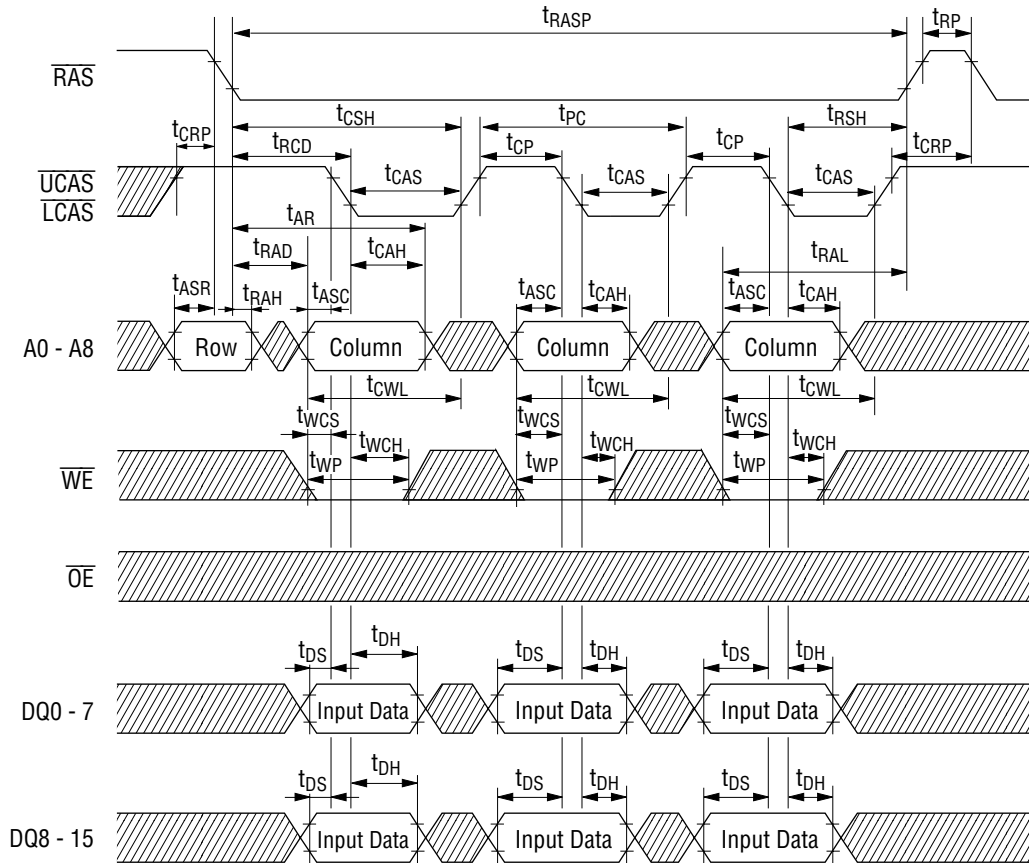

 "H" or "L"

Fast Page Mode Read Modify Write Cycle

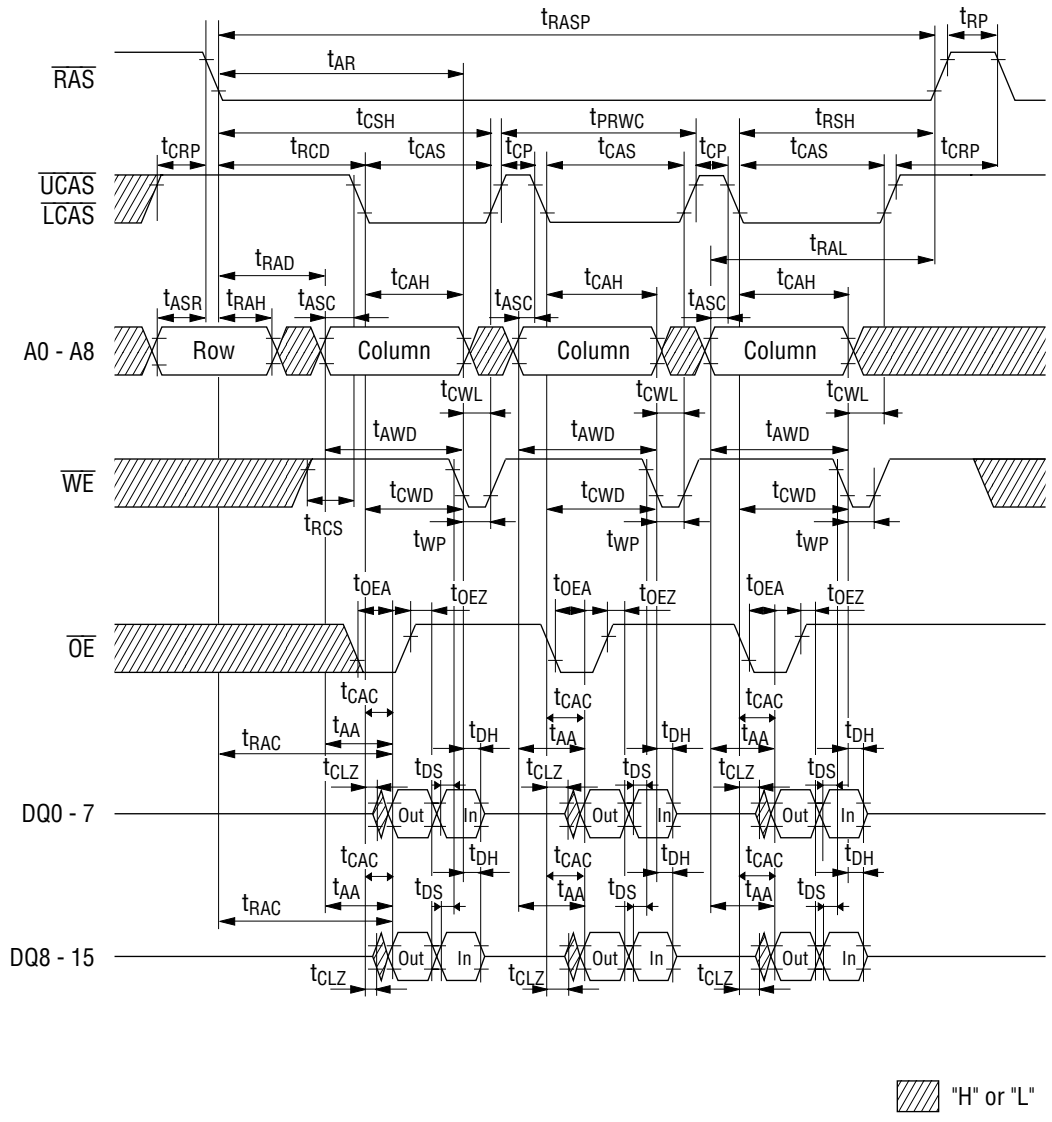

CAS before RAS Refresh Cycle

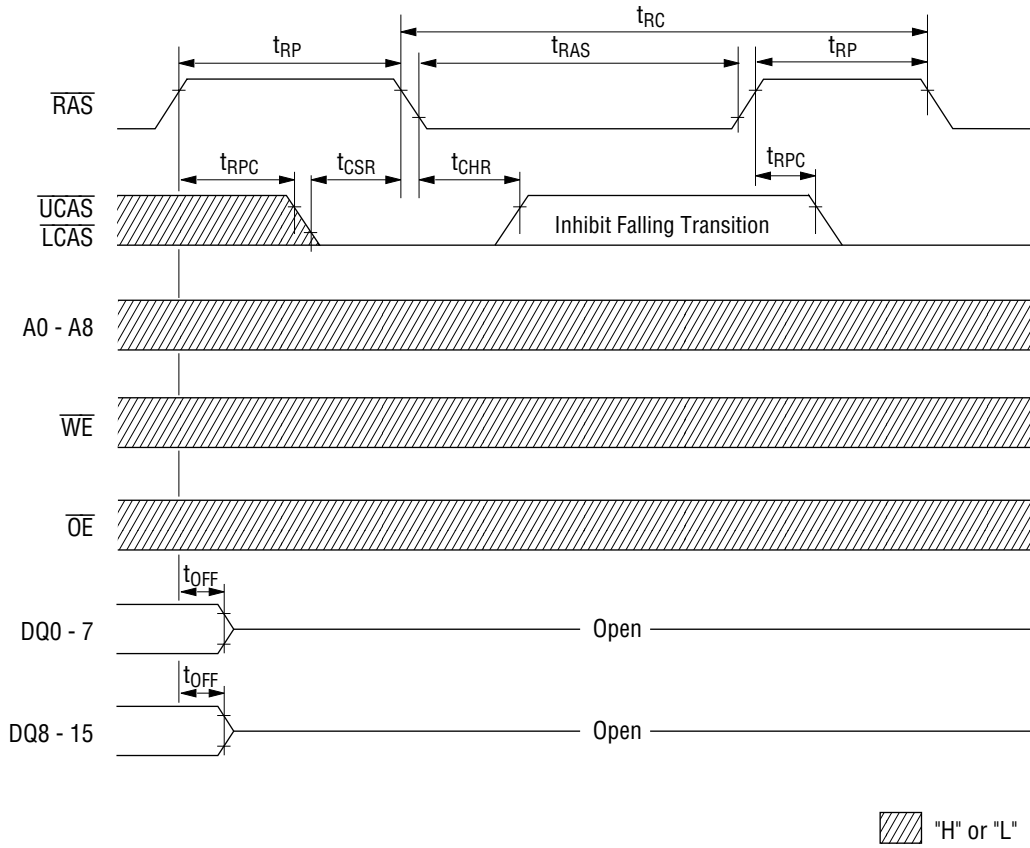

Hidden Refresh Cycle

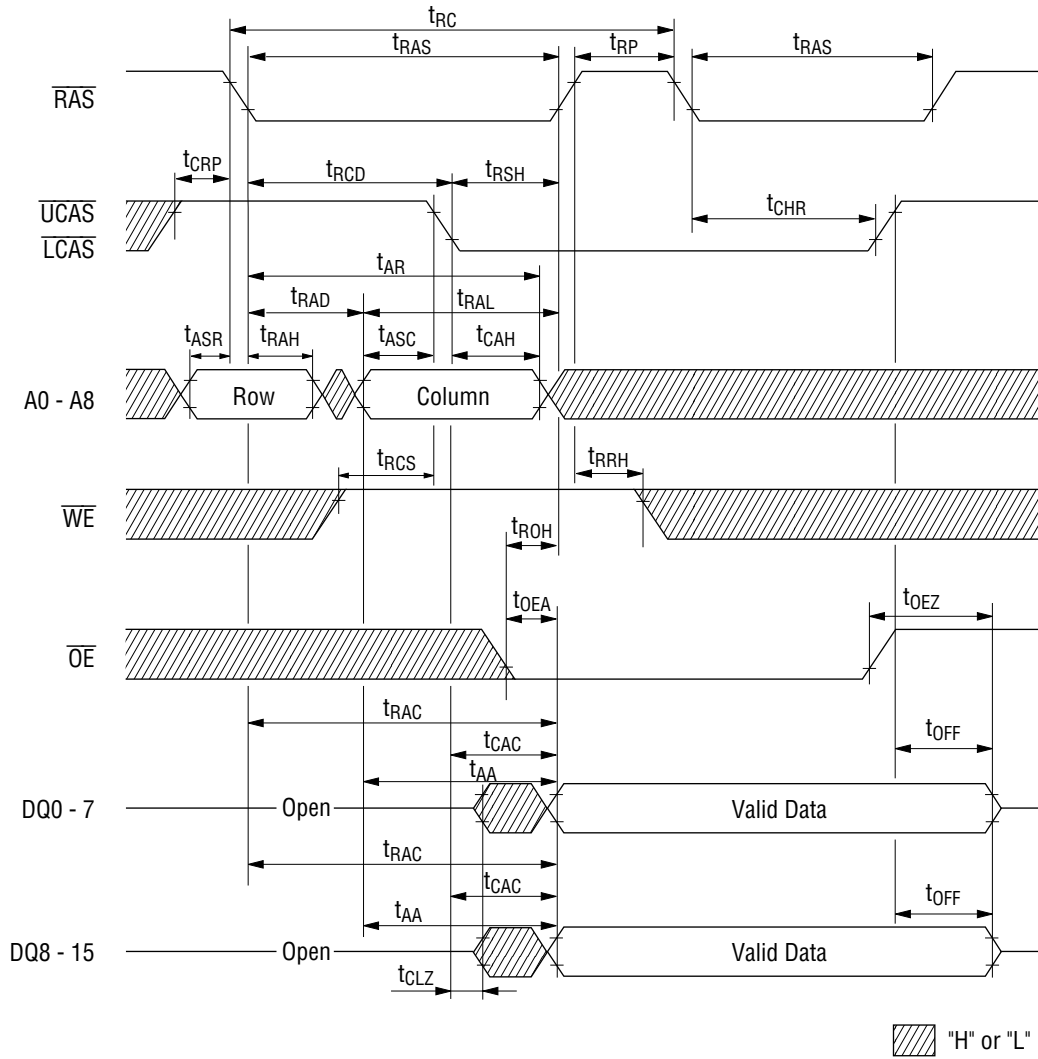

RAS Only Refresh Cycle

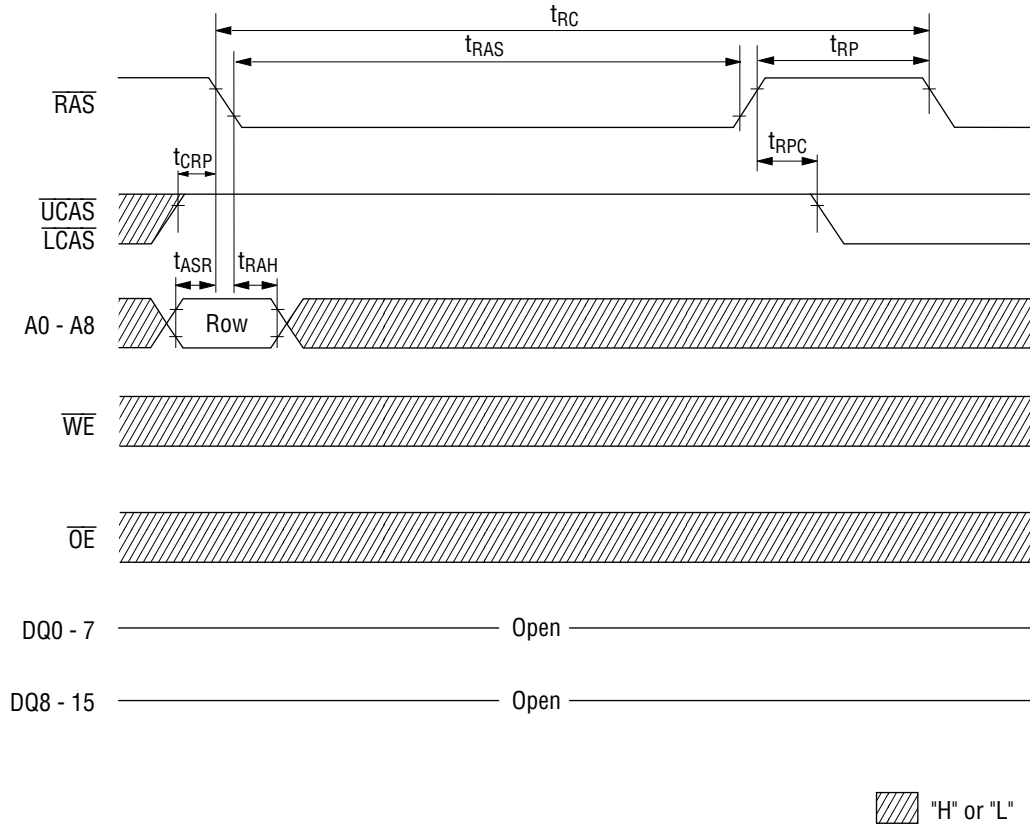

PACKAGE DIMENSIONS

(Unit : mm)

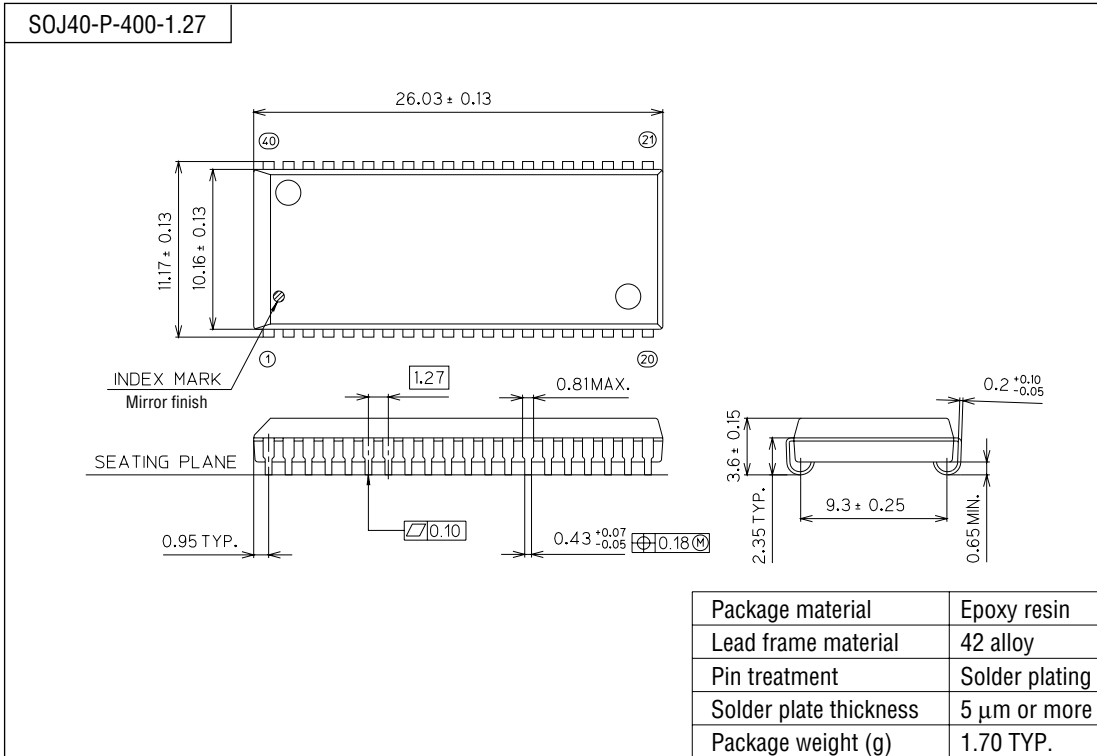

Notes for Mounting the Surface Mount Type Package

The SOP, QFP, TSOP, SOJ, QFJ (PLCC), SHP and BGA are surface mount type packages, which are very susceptible to heat in reflow mounting and humidity absorbed in storage. Therefore, before you perform reflow mounting, contact Oki's responsible sales person for the product name, package name, pin number, package code and desired mounting conditions (reflow method, temperature and times).

(Unit : mm)

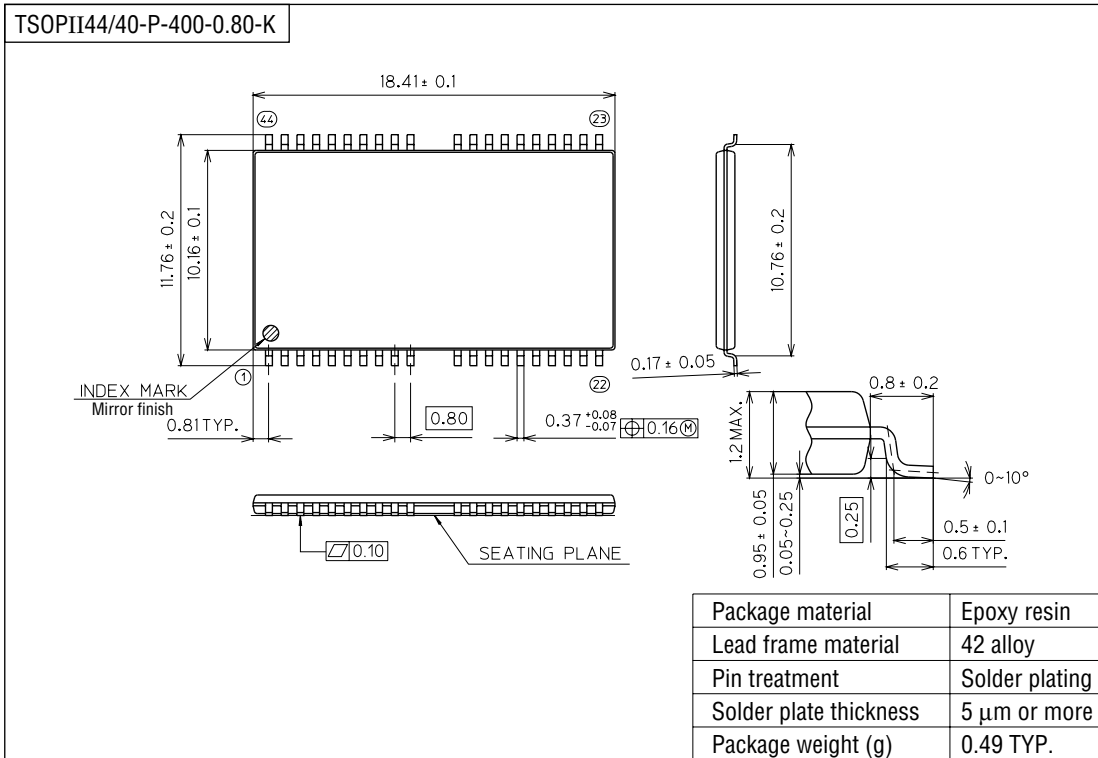

Notes for Mounting the Surface Mount Type Package

The SOP, QFP, TSOP, SOJ, QFJ (PLCC), SHP and BGA are surface mount type packages, which are very susceptible to heat in reflow mounting and humidity absorbed in storage. Therefore, before you perform reflow mounting, contact Oki's responsible sales person for the product name, package name, pin number, package code and desired mounting conditions (reflow method, temperature and times).