

# High Voltage, High Gain BIMOSFET™ Monolithic Bipolar MOS Transistor

**IXBH 42N170**  
**IXBT 42N170**

$$V_{CES} = 1700 \text{ V}$$

$$I_{C25} = 75 \text{ A}$$

$$V_{CE(sat)} = 3.3 \text{ V}$$

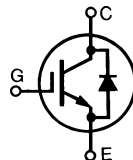

Symbol	Test Conditions	Maximum Ratings	
$V_{CES}$	$T_J = 25^\circ\text{C}$ to $150^\circ\text{C}$	1700	V
$V_{CGR}$	$T_J = 25^\circ\text{C}$ to $150^\circ\text{C}$ ; $R_{GE} = 1 \text{ M}\Omega$	1700	V
$V_{GES}$	Continuous	$\pm 20$	V
$V_{GEM}$	Transient	$\pm 30$	V
$I_{C25}$	$T_C = 25^\circ\text{C}$	75	A
$I_{C90}$	$T_C = 90^\circ\text{C}$	42	A
$I_{CM}$	$T_C = 25^\circ\text{C}$ , 1 ms	180	A
<b>SSOA</b> <b>(RBSOA)</b>	$V_{GE} = 15 \text{ V}$ , $T_{VJ} = 125^\circ\text{C}$ , $R_G = 10 \Omega$ Clamped inductive load	$I_{CM} = 90$ $V_{CES} = 1350$	A V
<b><math>T_{SC}</math></b> <b>(SCSOA)</b>	$V_{GE} = 15 \text{ V}$ , $V_{CES} = 1200 \text{ V}$ , $T_J = 125^\circ\text{C}$ $R_G = 10 \Omega$ non repetitive	10	$\mu\text{s}$
$P_C$	$T_C = 25^\circ\text{C}$	300	W
$T_J$		-55 ... +150	$^\circ\text{C}$
$T_{JM}$		150	$^\circ\text{C}$
$T_{stg}$		-55 ... +150	$^\circ\text{C}$
Maximum Lead temperature for soldering 1.6 mm (0.062 in.) from case for 10 s		300	$^\circ\text{C}$
Maximum Tab temperature for soldering SMD devices for 10 s		260	$^\circ\text{C}$
$M_d$	Mounting torque (M3)	1.13/10	Nm/lb.in.
<b>Weight</b>	TO-247 AD	6	g
	TO-268	4	g

**TO-268**  
**(IXBT)**

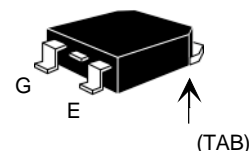

**TO-247 AD (IXBH)**

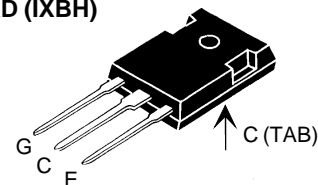

G = Gate, C = Collector,  
E = Emitter, TAB = Collector

### Features

- High Blocking Voltage
- JEDEC TO-268 surface and JEDEC TO-247 AD
- Low conduction losses
- High current handling capability
- MOS Gate turn-on - drive simplicity
- Molding epoxies meet UL 94 V-0 flammability classification

### Applications

- AC motor speed control
- Uninterruptible power supplies (UPS)
- Switched-mode and resonant-mode power supplies
- Capacitor discharge circuits

### Advantages

- Lower conduction losses than MOSFETs
- High power density
- Suitable for surface mounting
- Easy to mount with 1 screw, (isolated mounting screw hole)

Symbol	Test Conditions	Characteristic Values ( $T_J = 25^\circ\text{C}$ , unless otherwise specified)		
		min.	typ.	max.
$BV_{CES}$	$I_C = 250 \mu\text{A}$ , $V_{GE} = 0 \text{ V}$	1700		V
$V_{GE(th)}$	$I_C = 750 \mu\text{A}$ , $V_{CE} = V_{GE}$	2.5		V
$I_{CES}$	$V_{CE} = 0.8 V_{CES}$ $V_{GE} = 0 \text{ V}$	$T_J = 25^\circ\text{C}$		50 $\mu\text{A}$
		$T_J = 125^\circ\text{C}$		1.5 mA
$I_{GES}$	$V_{CE} = 0 \text{ V}$ , $V_{GE} = \pm 20 \text{ V}$			$\pm 100 \text{ nA}$
$V_{CE(sat)}$	$I_C = I_{C90}$ , $V_{GE} = 15 \text{ V}$			3.3 V
		$T_J = 125^\circ\text{C}$	2.9	V

Symbol	Test Conditions	Characteristic Values		
		(T <sub>J</sub> = 25°C, unless otherwise specified)		
		min.	typ.	max.
<b>g<sub>fs</sub></b>	I <sub>C</sub> = I <sub>C90</sub> , V <sub>CE</sub> = 10 V, Pulse test, t ≤ 300 μs, duty cycle ≤ 2 %	25	40	S
<b>C<sub>ies</sub></b>	V <sub>CE</sub> = 25 V, V <sub>GE</sub> = 0 V, f = 1 MHz		4700	pF
<b>C<sub>oes</sub></b>			213	pF
<b>C<sub>res</sub></b>			76	pF
<b>Q<sub>g</sub></b>	I <sub>C</sub> = I <sub>C90</sub> , V <sub>GE</sub> = 15 V, V <sub>CE</sub> = 0.5 V <sub>CES</sub>		169	nC
<b>Q<sub>ge</sub></b>			30	nC
<b>Q<sub>gc</sub></b>			52	nC
<b>t<sub>d(on)</sub></b>	<b>Inductive load, T<sub>J</sub> = 25°C</b> I <sub>C</sub> = I <sub>C90</sub> , V <sub>GE</sub> = 15 V V <sub>CE</sub> = 0.8 V <sub>CES</sub> , R <sub>G</sub> = R <sub>off</sub> = 10 Ω Remarks: Switching times may increase for V <sub>CE</sub> (Clamp) > 0.8 • V <sub>CES</sub> , higher T <sub>J</sub> or increased R <sub>G</sub>		45	ns
<b>t<sub>ri</sub></b>			35	ns
<b>t<sub>d(off)</sub></b>			400	ns
<b>t<sub>fi</sub></b>			1500	ns
<b>E<sub>off</sub></b>			36	mJ
<b>t<sub>d(on)</sub></b>	<b>Inductive load, T<sub>J</sub> = 125°C</b> I <sub>C</sub> = I <sub>C90</sub> , V <sub>GE</sub> = 15 V V <sub>CE</sub> = 0.8 V <sub>CES</sub> , R <sub>G</sub> = R <sub>off</sub> = 10 Ω Remarks: Switching times may increase for V <sub>CE</sub> (Clamp) > 0.8 • V <sub>CES</sub> , higher T <sub>J</sub> or increased R <sub>G</sub>		45	ns
<b>t<sub>ri</sub></b>			38	ns
<b>E<sub>on</sub></b>			50	mJ
<b>t<sub>d(off)</sub></b>			560	ns
<b>t<sub>fi</sub></b>			1900	ns
<b>E<sub>off</sub></b>		45	mJ	
<b>R<sub>thJC</sub></b>				0.42 K/W
<b>R<sub>thCK</sub></b>	(TO-247)		0.25	K/W

Symbol	Test Conditions	Characteristic Values		
		(T <sub>J</sub> = 25°C, unless otherwise specified)		
		min.	typ.	max.
<b>V<sub>F</sub></b>	I <sub>F</sub> = I <sub>C90</sub> , V <sub>GE</sub> = 0 V, Pulse test, t ≤ 300 us, duty cycle d ≤ 2%			4.0 V
<b>I<sub>RM</sub></b>	I <sub>F</sub> = 25A, V <sub>GE</sub> = 0 V, -di <sub>F</sub> /dt = 50 A/us V <sub>R</sub> = 100V		24	A
<b>t<sub>rr</sub></b>			360	ns

### Min. Recommended Footprint

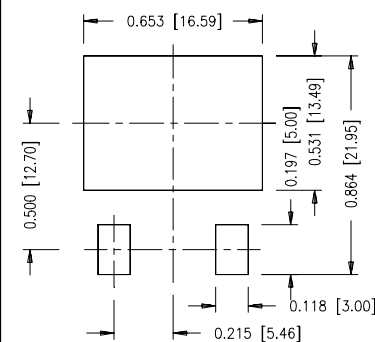

### TO-247 AD Outline

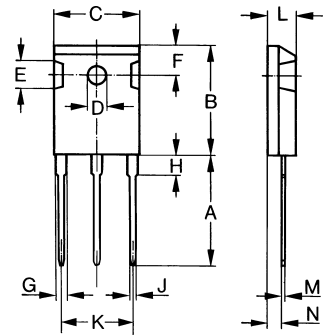

Dim.	Millimeter		Inches	
	Min.	Max.	Min.	Max.
A	19.81	20.32	0.780	0.800
B	20.80	21.46	0.819	0.845
C	15.75	16.26	0.610	0.640
D	3.55	3.65	0.140	0.144
E	4.32	5.49	0.170	0.216
F	5.4	6.2	0.212	0.244
G	1.65	2.13	0.065	0.084
H	-	4.5	-	0.177
J	1.0	1.4	0.040	0.055
K	10.8	11.0	0.426	0.433
L	4.7	5.3	0.185	0.209
M	0.4	0.8	0.016	0.031
N	1.5	2.49	0.087	0.102

### TO-268AA (D<sup>3</sup> PAK)

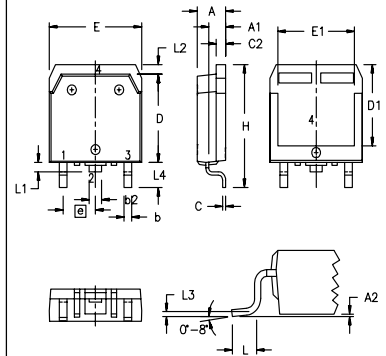

Dim.	Millimeter		Inches	
	Min.	Max.	Min.	Max.
A	4.9	5.1	.193	.201
A <sub>1</sub>	2.7	2.9	.106	.114
A <sub>2</sub>	.02	.25	.001	.010
b	1.15	1.45	.045	.057
b <sub>2</sub>	1.9	2.1	.75	.83
C	.4	.65	.016	.026
D	13.80	14.00	.543	.551
E	15.85	16.05	.624	.632
E <sub>1</sub>	13.3	13.6	.524	.535
e	5.45 BSC		.215 BSC	
H	18.70	19.10	.736	.752
L	2.40	2.70	.094	.106
L <sub>1</sub>	1.20	1.40	.047	.055
L <sub>2</sub>	1.00	1.15	.039	.045
L <sub>3</sub>	0.25 BSC		.010 BSC	
L <sub>4</sub>	3.80	4.10	.150	.161