

Features

- Incorporates the ARM7TDMI® ARM® Thumb® Processor
 - High-performance 32-bit RISC Architecture
 - High-density 16-bit Instruction Set
 - Leader in MIPS/Watt
 - EmbeddedICE™ In-circuit Emulation, Debug Communication Channel Support
- Internal High-speed Flash
 - 128 Kbytes (AT91SAM7L128), Organized in 512 Pages of 256 Bytes Single Plane
 - 64 Kbytes (AT91SAM7L64), Organized In 256 Pages of 256 Bytes Single Plane
 - Single Cycle Access at Up to 15 MHz in Worst Case Conditions
 - 128-bit Read Access
 - Page Programming Time: 4.6 ms, Including Page Auto Erase, Full Erase Time: 10 ms
 - 10,000 Write Cycles, 10-year Data Retention Capability, Sector Lock Capabilities, Flash Security Bit
 - Fast Flash Programming Interface for High Volume Production
- Internal High-speed SRAM, Single-cycle Access at Maximum Speed
 - 6 Kbytes
 - 2 Kbytes Directly on Main Supply That Can Be Used as Backup SRAM
 - 4 Kbytes in the Core
- Memory Controller (MC)
 - Enhanced Embedded Flash Controller, Abort Status and Misalignment Detection
- Enhanced Embedded Flash Controller (EEFC)
 - Interface of the Flash Block with the 32-bit Internal Bus
 - Increases Performance in ARM and Thumb Mode with 128-bit Wide Memory Interface
- Reset Controller (RSTC)
 - Based on Zero-power Power-on Reset and Fully Programmable Brownout Detector
 - Provides External Reset Signal Shaping and Reset Source Status
- Clock Generator (CKGR)
 - Low-power 32 kHz RC Oscillator, 32 kHz On-chip Oscillator, 2 MHz Fast RC Oscillator and one PLL
- Supply Controller (SUPC)
 - Minimizes Device Power Consumption
 - Manages the Different Supplies On Chip
 - Supports Multiple Wake-up Sources
- Power Management Controller (PMC)
 - Software Power Optimization Capabilities, Including Active and Four Low Power Modes:
 - Idle Mode: No Processor Clock
 - Wait Mode: No Processor Clock, Voltage Regulator Output at Minimum
 - Backup Mode: Voltage Regulator and Processor Switched Off
 - Off (Power Down) Mode: Entire Chip Shut Down Except for Force Wake Up Pin (FWUP) that Re-activates the Device. 100 nA Current Consumption.
- In Active Mode, Dynamic Power Consumption <30 mA at 36 MHz
 - Three Programmable External Clock Signals
 - Handles Fast Start Up



AT91 ARM Thumb-based Microcontroller

AT91SAM7L128 AT91SAM7L64

Summary

Preliminary

NOTE: This is a summary document. The complete document is available on the Atmel website at www.atmel.com.

6257AS-ATARM-28-Feb-08





- **Advanced Interrupt Controller (AIC)**
 - Individually Maskable, Eight-level Priority, Vectored Interrupt Sources
 - Two External Interrupt Sources and One Fast Interrupt Source, Spurious Interrupt Protected
- **Debug Unit (DBGU)**
 - Two-wire UART and Support for Debug Communication Channel interrupt, Programmable ICE Access Prevention
- **Periodic Interval Timer (PIT)**
 - 20-bit Programmable Counter plus 12-bit Interval Counter
- **Windowed Watchdog (WDT)**
 - 12-bit Key-protected Programmable Counter
 - Provides Reset or Interrupt Signals to the System
 - Counter may be Stopped While the Processor is in Debug State or in Idle Mode
- **Real-time Clock (RTC)**
 - Two Hundred Year Calendar with Alarm
 - Runs Off the Internal RC or Crystal Oscillator
- **Three Parallel Input/Output Controllers (PIOA, PIOB, PIOC)**
 - Eighty Programmable I/O Lines Multiplexed with up to Two Peripheral I/Os
 - Input Change Interrupt Capability on Each I/O Line
 - Individually Programmable Open-drain, Pull-up resistor and Synchronous Output
- **Eleven Peripheral DMA Controller (PDC) Channels**
- **One Segment LCD Controller**
 - Display Capacity of Forty Segments and Ten Common Terminals
 - Software Selectable LCD Output Voltage (Contrast)
- **Two Universal Synchronous/Asynchronous Receiver Transmitters (USART)**
 - Individual Baud Rate Generator, IrDA[®] Infrared Modulation/Demodulation
 - Support for ISO7816 T0/T1 Smart Card, Hardware Handshaking, RS485 Support
 - Manchester Encoder/Decoder
 - Full Modem Line Support on USART1
- **One Master/Slave Serial Peripheral Interface (SPI)**
 - 8- to 16-bit Programmable Data Length, Four External Peripheral Chip Selects
- **One Three-channel 16-bit Timer/Counter (TC)**
 - Three External Clock Inputs, Two Multi-purpose I/O Pins per Channel
 - Double PWM Generation, Capture/Waveform Mode, Up/Down Capability
- **One Four-channel 16-bit PWM Controller (PWMC)**
- **One Two-wire Interface (TWI)**
 - Master, Multi-Master and Slave Mode Support, All Atmel[®] Two-wire EEPROMs and I²C compatible Devices Supported
 - General Call Supported in Slave Mode
- **One 4-channel 10-bit Analog-to-Digital Converter, Four Channels Multiplexed with Digital I/Os**
- **SAM-BA[®] Boot Assistant**
 - Default Boot Program
 - Interface with SAM-BA Graphic User Interface
 - In Application Programming Function (IAP)
- **IEEE[®] 1149.1 JTAG Boundary Scan on All Digital Pins**
- **Four High-current Drive I/O lines, Up to 4 mA Each**
- **Power Supplies**
 - Embedded 1.8V Regulator, Drawing up to 60 mA for the Core with Programmable Output Voltage
 - Single Supply 1.8V - 3.6V
- **Fully Static Operation: Up to 36 MHz at 85°C, Worst Case Conditions**
- **Available in a 128-lead LQFP Green and a 144-ball LFBGA Green Package**

1. Description

The AT91SAM7L128/64 are low power members of Atmel's Smart ARM Microcontroller family based on the 32-bit ARM7™ RISC processor and high-speed Flash memory.

- AT91SAM7L128 features a 128 Kbyte high-speed Flash and a total of 6 Kbytes SRAM.
- AT91SAM7L64 features a 64 Kbyte high-speed Flash and a total of 6 Kbytes SRAM.

They also embed a large set of peripherals, including a Segment LCD Controller and a complete set of system functions minimizing the number of external components.

These devices provide an ideal migration path for 8-bit microcontroller users looking for additional performance, extended memory and higher levels of system integration with strong constraints on power consumption.

Featuring innovative power reduction modes and ultra-low-power operation, the AT91SAM7L128/64 is tailored for battery operated applications such as calculators, toys, remote controls, medical devices, mobile phone accessories and wireless sensors.

The embedded Flash memory can be programmed in-system via the JTAG-ICE interface or via a parallel interface on a production programmer prior to mounting. Built-in lock bits and a security bit protect the firmware from accidental overwrite and preserve its confidentiality.

The AT91SAM7L128/64 system controller includes a reset controller capable of managing the power-on sequence of the microcontroller and the complete system. Correct device operation can be monitored by a built-in brownout detector and a watchdog running off an integrated oscillator.

By combining the ARM7TDMI processor with on-chip Flash and SRAM, and a wide range of peripheral functions, including USART, SPI, External Bus Timer Counter, RTC and Analog-to-Digital Converters on a monolithic chip, the AT91SAM7L128/64 microcontroller is a powerful device that provides a flexible, cost-effective solution to many embedded control applications.

2. Block Diagram

Figure 2-1. AT91SAM7L128/64 Block Diagram

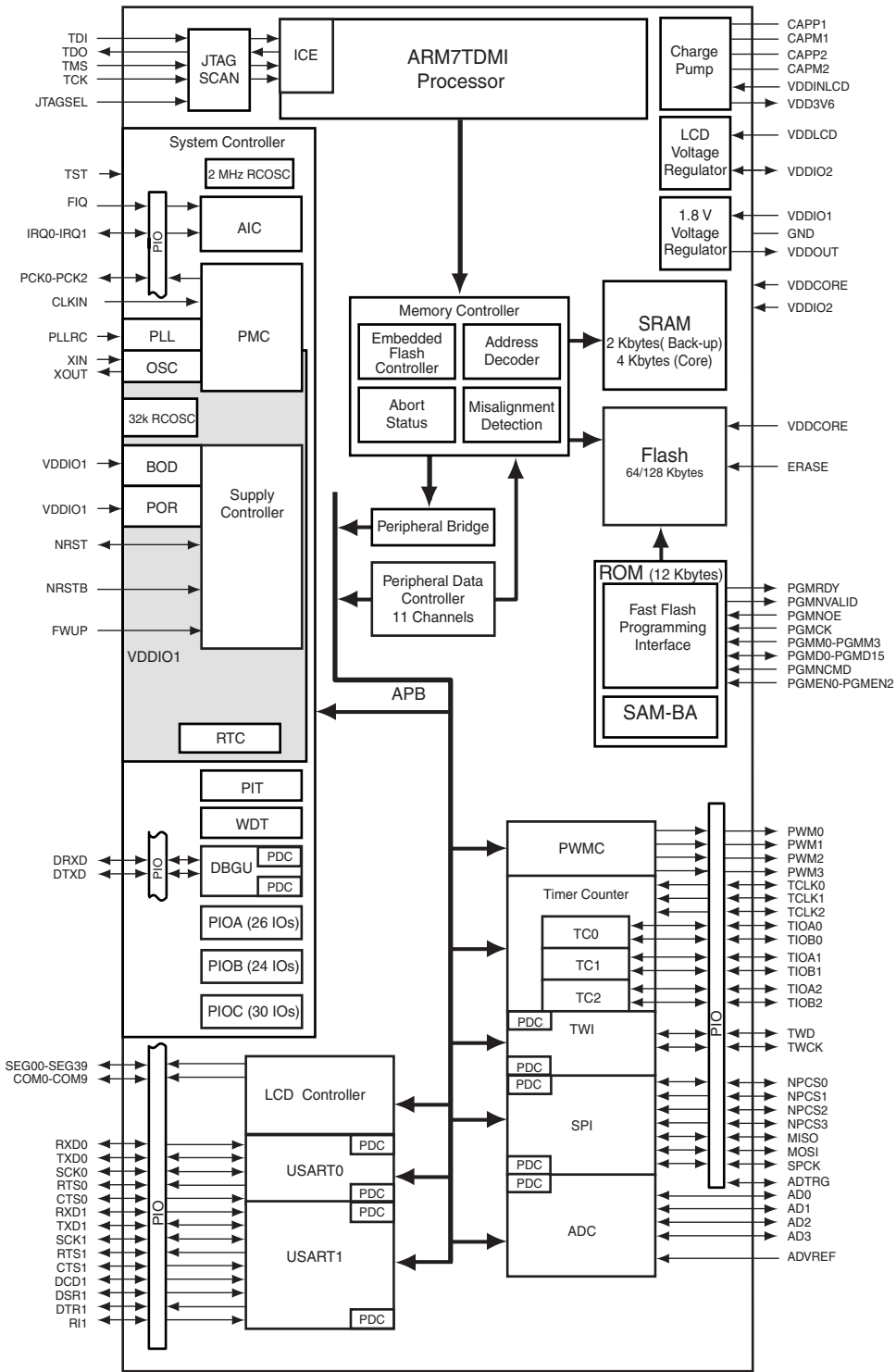

3. Signal Description

Table 3-1. Signal Description List

Signal Name	Function	Type	Active Level	Voltage Reference	Comments
Power					
VDDIO1	I/O Lines (PIOC) and Voltage Regulator Power Supply	Power			From 1.80V to 3.6V
VDDOUT	Voltage Regulator Output	Power			
VDDCORE	Core Power Supply	Power			Connected externally to VDDOUT
VDDINLCD	Charge Pump Power Supply	Power			From 1.80V to 3.6V
VDD3V6	Charge Pump Output	Power			
VDDLCD	LCD Voltage Regulator Power Supply	Power			
VDDIO2	LCD Voltage Regulator Output and LCD I/O Lines Power Supply (PIOA and PIOB)	Power			1.80V to 3.6V
CAPP1	Charge pump capacitor 1	Power			Capacitor needed between CAPP1 and CAPM1.
CAPM1	Charge pump capacitor 1	Power			
CAPP2	Charge pump capacitor 2	Power			Capacitor needed between CAPP2 and CAPM2.
CAPM2	Charge pump capacitor 2	Power			
FWUP	Force Wake-up	Input	Low	VDDIO1	Needs external Pull-up.
WKUP0-15	Wake-up inputs used in Backup mode and Fast Start-up inputs in Wait mode	Input		VDDIO1	
GND	Ground	Ground			
Clocks, Oscillators and PLLs					
XIN	32 kHz Oscillator Input	Input		VDDIO1	
XOUT	32 kHz Oscillator Output	Output		VDDIO1	
CLKIN	Main Clock input	Input		VDDIO1	Should be tied low when not used.
PCK0 - PCK2	Programmable Clock Output	Output			
PLLRC	PLL Filter	Input		VDDCORE	
PLLRCGND	PLL RC Filter Ground	Power			Must not be connected to external Ground.
ICE and JTAG					
TCK	Test Clock	Input		VDDIO1	No internal pull-up resistor
TDI	Test Data In	Input		VDDIO1	No internal pull-up resistor
TDO	Test Data Out	Output		VDDIO1	
TMS	Test Mode Select	Input		VDDIO1	No internal pull-up resistor
JTAGSEL	JTAG Selection	Input		VDDIO1	Internal Pull-down resistor
Flash Memory					
ERASE	Flash and NVM Configuration Bits Erase Command	Input	High	VDDIO1	Internal Pull-down (15 kΩ) resistor



Table 3-1. Signal Description List (Continued)

Signal Name	Function	Type	Active Level	Voltage Reference	Comments
Reset/Test					
NRST	Microcontroller Reset	I/O	Low	VDDIO1	Internal Pull-up (100 kΩ) resistor
TST	Test Mode Select	Input	High	VDDIO1	Internal Pull-down (15 kΩ) resistor
NRSTB	Asynchronous Master Reset	Input	Low	VDDIO1	Internal Pull-up (15 kΩ) resistor
Debug Unit					
DRXD	Debug Receive Data	Input			
DTXD	Debug Transmit Data	Output			
AIC					
IRQ0 - IRQ1	External Interrupt Inputs	Input			
FIQ	Fast Interrupt Input	Input			
PIO					
PA0 - PA25	Parallel IO Controller A	I/O		VDDIO2	Pulled-up input at reset
PB0 - PB23	Parallel IO Controller B	I/O		VDDIO2	Pulled-up input at reset
PC0 - PC29	Parallel IO Controller C	I/O		VDDIO1	Pulled-up input at reset
USART					
SCK0 - SCK1	Serial Clock	I/O			
TXD0 - TXD1	Transmit Data	I/O			
RXD0 - RXD1	Receive Data	Input			
RTS0 - RTS1	Request To Send	Output			
CTS0 - CTS1	Clear To Send	Input			
DCD1	Data Carrier Detect	Input			
DTR1	Data Terminal Ready	Output			
DSR1	Data Set Ready	Input			
RI1	Ring Indicator	Input			
Timer/Counter					
TCLK0 - TCLK2	External Clock Inputs	Input			
TIOA0 - TIOA2	Timer Counter I/O Line A	I/O			
TIOB0 - TIOB2	Timer Counter I/O Line B	I/O			
PWM Controller					
PWM0 - PWM3	PWM Channels	Output			
Serial Peripheral Interface					
MISO	Master In Slave Out	I/O			
MOSI	Master Out Slave In	I/O			
SPCK	SPI Serial Clock	I/O			
NPCS0	SPI Peripheral Chip Select 0	I/O	Low		
NPCS1-NPCS3	SPI Peripheral Chip Select 1 to 3	Output	Low		

Table 3-1. Signal Description List (Continued)

Signal Name	Function	Type	Active Level	Voltage Reference	Comments
Two-Wire Interface					
TWD	Two-wire Serial Data	I/O			
TWCK	Two-wire Serial Clock	I/O			
Analog-to-Digital Converter					
AD0-AD3	Analog Inputs	Input		VDDCORE	
ADTRG	ADC Trigger	Input			
ADVREF	ADC Reference	Analog		VDDCORE	
Fast Flash Programming Interface					
PGMEN0-PGMEN2	Programming Enabling	Input		VDDIO1	
PGMM0-PGMM3	Programming Mode	Input		VDDIO1	
PGMD0-PGMD15	Programming Data	I/O		VDDIO1	
PGMRDY	Programming Ready	Output	High	VDDIO1	
PGMNVALID	Data Direction	Output	Low	VDDIO1	
PGMNOE	Programming Read	Input	Low	VDDIO1	
PGMCK	Programming Clock	Input		VDDIO1	
PGMNCMD	Programming Command	Input	Low	VDDIO1	
Segmented LCD Controller					
COM[9:0]	Common Terminals	Output		VDDIO2	
SEG[39:0]	Segment Terminals	Output		VDDIO2	

4. Package and Pinout

The AT91SAM7L128/64 is available in:

- 20 x 14 mm 128-lead LQFP package with a 0.5 mm lead-pitch
- 10 x 10 mm 144-ball LFBGA package with a 0.8 mm pitch.

The part is also available in die delivery.

4.1 128-lead LQFP Package Outline

Figure 4-1 shows the orientation of the 128-lead LQFP package.

A detailed mechanical description is given in the Mechanical Characteristics section of the product datasheet.

Figure 4-1. 128-lead LQFP Package Outline (Top View)

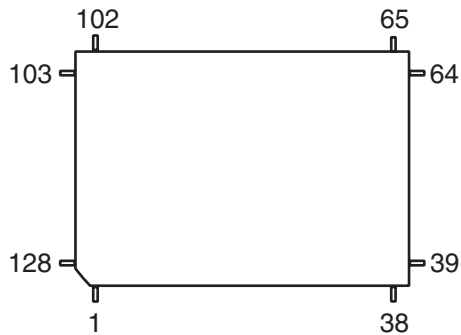

4.2 128-lead LQFP Package Pinout

Table 4-1. Pinout for 128-lead LQFP Package

1	TST	33	VDDLCD	65	PB21	97	PC10/PGMM3
2	VDDCORE	34	VDD3V6	66	PB22	98	PC11/PGMD0
3	PA0	35	CAPM2	67	PB23	99	PC12/PGMD1
4	PA1	36	CAPP2	68	GND	100	VDDCORE
5	PA2	37	CAPM1	69	ADVREF	101	PC13/PGMD2
6	PA3	38	CAPP1	70	AD3	102	PC14/PGMD3
7	PA4	39	VDDINLCD	71	AD2	103	PC15/PGMD4
8	PA5	40	GND	72	AD1	104	PC16/PGMD5
9	PA6	41	PB0	73	AD0	105	PC17/PGMD6
10	PA7	42	PB1	74	VDDOUT	106	PC18/PGMD7
11	PA8	43	PB2	75	VDDIO1	107	PC19/PGMD8
12	PA9	44	PB3	76	GND	108	PC20/PGMD9
13	PA10	45	PB4	77	PC28	109	PC21/PGMD10
14	GND	46	PB5	78	PC29	110	PC22/PGMD11
15	VDDIO2	47	PB6	79	NRST	111	PC23/PGMD12
16	PA11	48	PB7	80	ERASE	112	PC24/PGMD13
17	PA12	49	PB8	81	TCK	113	PC25/PGMD14
18	PA13	50	PB9	82	TMS	114	PC26/PGMD15
19	PA14	51	PB10	83	JTAGSEL	115	PC27
20	PA15	52	PB11	84	VDDCORE	116	TDI
21	PA16	53	PB12	85	VDDIO1	117	TDO
22	PA17	54	PB13	86	GND	118	FWUP
23	PA18	55	VDDIO2	87	PC0/PGMEN0	119	VDDIO1
24	PA19	56	GND	88	PC1/PGMEN1	120	GND
25	PA20	57	PB14	89	PC2/PGMEN2	121	PLLRC
26	PA21	58	PB15	90	PC3/PGMNCMD	122	PLLRCGND
27	PA22	59	PB16	91	PC4/PGMRDY	123	GND
28	VDDCORE	60	PB17	92	PC5/PGMNOE	124	VDDCORE
29	PA23	61	PB18	93	PC6/PGMNVALID	125	CLKIN
30	PA24	62	VDDCORE	94	PC7/PGMM0	126	NRSTB
31	PA25	63	PB19	95	PC8/PGMM1	127	XIN/PGMCK
32	VDDIO2	64	PB20	96	PC9/PGMM2	128	XOUT

4.3 144-ball LFBGA Package Outline

Figure 4-2 shows the orientation of the 144-ball LFBGA package.

A detailed mechanical description is given in the Mechanical Characteristics section of the product datasheet.

Figure 4-2. 144-ball LFBGA Package Outline (Top View)

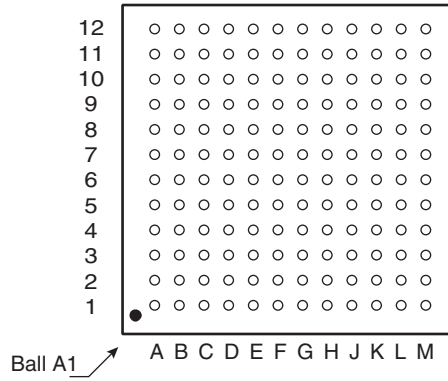

4.4 144-ball LFBGA Pinout

Table 4-2. SAM7L128/64 Pinout for 144-ball LFBGA Package

Pin	Signal Name	Pin	Signal Name	Pin	Signal Name	Pin	Signal Name
A1	XOUT	D1	PA6	G1	VDD3V6	K1	CAPM1
A2	XIN	D2	PA5	G2	PA17	K2	VDDIO2
A3	VDDCORE	D3	PA7	G3	PA16	K3	VDDIO2
A4	GND	D4	NC	G4	PA15	K4	PA25
A5	PLLRCGND	D5	PC26/PGMD15	G5	GND	K5	PB3
A6	PLLRC	D6	PC25/PGMD14	G6	GND	K6	PB10
A7	PC24/PGMD13	D7	PC21/PGMD11	G7	GND	K7	PB13
A8	PC23//PGMD12	D8	PC18/PGMD7	G8	VDDIO1	K8	PB15
A9	PC17/PGMD6	D9	PC6/PGMNVALID	G9	NRST	K9	PB20
A10	NC	D10	PC7/PGMM0	G10	TMS	K10	VDDCORE
A11	PC14	D11	PC4/PGMRDY	G11	ERASE	K11	VDDCORE
A12	PC12	D12	PC3/PGMNCMD	G12	VDDOUT	K12	AD2
B1	PA1	E1	VDDIO2	H1	CAPM2	L1	CAPP1
B2	PA0	E2	PA10	H2	PA22	L2	VDDIO2
B3	NRSTB	E3	PA9	H3	PA19	L3	VDDIO2
B4	TEST	E4	PA11	H4	PA18	L4	PB4
B5	TDO	E5	PA8	H5	GND	L5	PB5
B6	PC27	E6	VDDIO1	H6	GND	L6	PB11
B7	GND	E7	VDDIO1	H7	GND	L7	PB12
B8	NC	E8	VDDIO1	H8	VDDCORE	L8	PB17
B9	PC20/PGMD9	E9	PC5/PGMNOE	H9	PC29	L9	PB19
B10	PC15/PGMD4	E10	PC0/PGMEN0	H10	VDDCORE	L10	PB22
B11	PC13/PGMD2	E11	PC2/PGMEN2	H11	PC28	L11	PB23
B12	PC11/PGMD0	E12	VDDCORE	H12	AD0	L12	AD3
C1	PA3	F1	VDDLCD	J1	CAPP2	M1	VDDINLCD
C2	PA4	F2	PA13	J2	PA23	M2	PB0
C3	PA2	F3	PA14	J3	PA24	M3	PB1
C4	CLKIN	F4	PA12	J4	PA21	M4	PB2
C5	FWUP	F5	GND	J5	PA20	M5	PB6
C6	TDI	F6	GND	J6	PB8	M6	PB7
C7	PC22/PGMD11	F7	GND	J7	PB9	M7	VDDIO2
C8	PC19/PGMD8	F8	VDDIO1	J8	PB14	M8	PB16
C9	PC16/PGMD5	F9	TCK	J9	VDDCORE	M9	PB18
C10	PC9/PGMM2	F10	JTAGSEL	J10	VDDCORE	M10	PB21
C11	PC10/PGMM3	F11	PC1/PGMEN1	J11	VDDCORE	M11	GND
C12	PC8/PGMM1	F12	VDDIO1	J12	AD1	M12	ADVREF

5. Power Considerations

5.1 Power Supplies

The AT91SAM7L128/64 has six types of power supply pins and integrates a voltage regulator, allowing the device to be supplied with only one voltage. The six power supply pin types are:

- VDDOUT pin. It is the output of the voltage regulator. Output voltage can be programmed from 1.55V to 1.80V by steps of 100 mV.
- VDDIO1 pin. It powers the voltage regulator input and all the PIOC IO lines (1.8V-3.6V). VDDIO1 voltage must be above 2.2V to allow the chip to start-up (POR threshold).
- VDDIO2 pin. It powers the PIOA and PIOB I/O lines (1.8V-3.6V). It is also the output of the LCD voltage regulator. The output voltage can be programmed from 2.4V to 3.4V with 16 steps.
- VDDCORE pin. It powers the logic of the device, the PLL, the 2 MHz Fast RC oscillator, the ADC and the Flash memory. It must be connected to the VDDOUT pin with a decoupling capacitor.
- VDDINLCD pin. It powers the charge pump which can be used as LCD Regulator power supply. Voltage ranges from 1.8V to 3.6V.

No separate ground pins are provided for the different power supplies. Only GND pins are provided and should be connected as shortly as possible to the system ground plane.

5.2 Low Power Modes

The various low power modes of the AT91SAM7L128/64 are described below.

5.2.1 Off (Power Down) Mode

In off (power down) mode, the entire chip is shut down. Only a low level on the FWUP pin can wake up the AT91SAM7L128/64 (by a push-button for example). Internally, except for the FWUP pin through VDDIO1, none of the chip is supplied.

Once the internal main power switch has been activated by FWUP, the 32 kHz RC oscillator and the Supply Controller are supplied, then the core and peripherals are reset and the AT91SAM7L128/64 enters in active mode. Refer to the System Controller Block Diagram, [Figure 9-1 on page 30](#).

At first power-up, if FWUP is tied high, the device enters off mode. The PIOA and PIOB pins' states are undefined. PIOC and NRST pins are initialized as high impedance inputs.

Once the device enters active mode, the core and the parallel input/output controller are reset. Then, if the chip enters off mode, PIOA and PIOB pins are configured as inputs with pull-ups and PIOC pins as high impedance inputs.

Current consumption in this mode is typically 100 nA.

5.2.2 Backup Mode

In backup mode, the supply controller, the zero-power power-on reset and the 32 kHz oscillator (software selectable internal RC or external crystal) remain running. The voltage regulator and the core are switched off.

Prior to entering this mode, the RTC, the backup SRAM, the brownout detector, the charge pump, the LCD voltage regulator and the LCD controller can be set on or off separately.

Table 5-1 on page 13 shows an example of backup mode with backup SRAM and RTC running.

When entering this mode, all PIO pins keep their previous states, they are reinitialized as inputs with pull-ups at wake-up.

The AT91SAM7L128/64 can be awakened from this mode through the FWUP pin, an event on WUP0-15 pins, or an RTC alarm or brownout event.

Current consumption is 3.5 μ A typical without the LCD controller running.

5.2.3 Wait Mode

In wait mode, the voltage regulator must be set in deep mode. Voltage regulator output voltage should be set at a minimum voltage to decrease leakage in the digital core. No clock is running in the core. From this mode, a fast start-up is available (refer to Section 5.4 "Fast Start-Up").

In this mode, all PIO pins keep their previous states.

5.2.4 Idle Mode

The processor is in idle mode which means that the processor has no clock but the Master clock (MCK) remains running. The processor can also be wakened by an IRQ or FIQ.

5.2.5 Active Mode

The total dynamic power consumption is less than 30 mA at full speed (36 MHz) when running out of the Flash. The power management controller can be used to adapt the frequency and the regulator output voltage can be adjusted to optimize power consumption.

5.2.6 Low Power Mode Summary Table

The modes detailed above are the main modes. In off mode, no options are available but once the shutdown controller is set to on, each part can be set to on, or off, separately and more modes can be active. The table below shows a summary of the configurations of the low power modes.

Table 5-1. Low Power Mode Configuration Summary

Mode	FWUP	SUPC, 32 kHz Oscillator, POR	RTC	Backup SRAM	Regulator (Deep Mode)	Core	Potential Wake-up Sources	Consumption ⁽²⁾⁽³⁾	Wake-up Time ⁽¹⁾
Off Mode	X						FWUP pin	100 nA typ	< 5 ms
Backup Mode (with SRAM and RTC)	X	X	X	X			FWUP pin WUP0-15 pins BOD alarm RTC alarm	3.5 μ A typ	< 0.5 ms
Wait Mode (with SRAM and RTC)	X	X	X	X	X	X	Fast start-up through WUP0-15 pins	9 μ A typ	< 2 μ s (in case of fast start-up)
Idle Mode	X	X		X	X	X	IRQs FIQ	(4)	(4)

- Notes:
1. When considering wake-up time, the time required to start the PLL is not taken into account. Once started, the AT91SAM7128/L64 works with the 2 MHz Fast RC oscillator. The user has to add the PLL start-up time if it is needed in the system. The wake-up time is defined as the time taken for wake up until the first instruction is fetched.
 2. The external LCD current consumption and the external loads on PIOs are not taken into account in the calculation.
 3. BOD current consumption is not included.
 4. Depends on MCK frequency.

5.3 Wake-up Sources

The wake-up events allow the device to exit from backup mode. When a wake-up event is detected, the supply controller performs a sequence which automatically reenables the voltage regulator and the backup SRAM power supply, if it is not already enabled.

Figure 5-1. Wake Up Sources

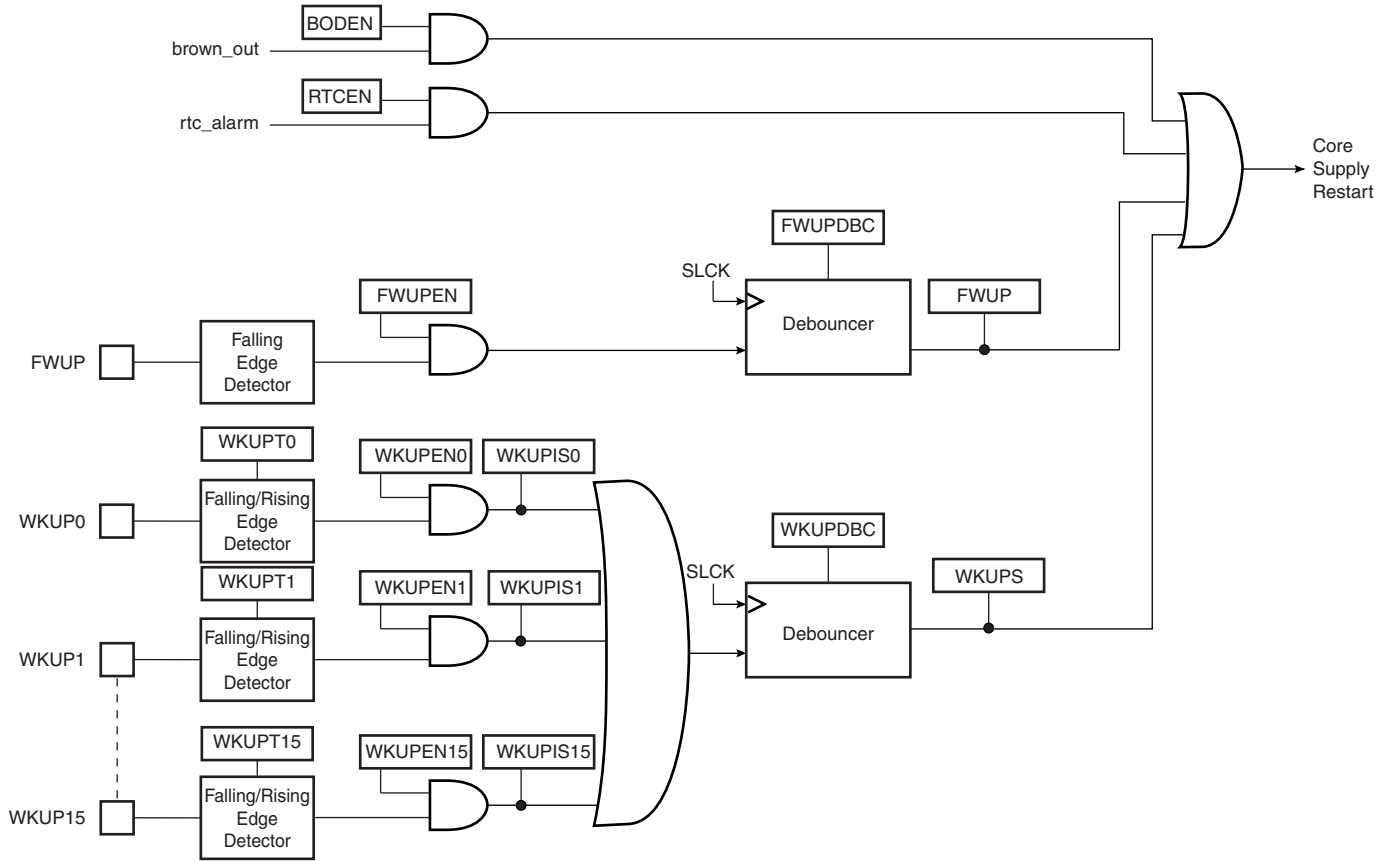

5.4 Fast Start-Up

The SAM7L128/64 allows the processor to restart in a few microseconds while the processor is in wait mode. A fast start up can occur upon detection of a low level on one of the 16 wake-up inputs.

The fast restart circuitry, as shown in Figure 5-2, is fully asynchronous and provides a fast start-up signal to the power management controller. As soon as the fast start-up signal is asserted, the PMC automatically restarts the embedded 2 MHz Fast RC oscillator, switches the master clock on this 2 MHz clock and reenables the processor clock, if it is disabled.

Figure 5-2. Fast Start-Up Circuitry

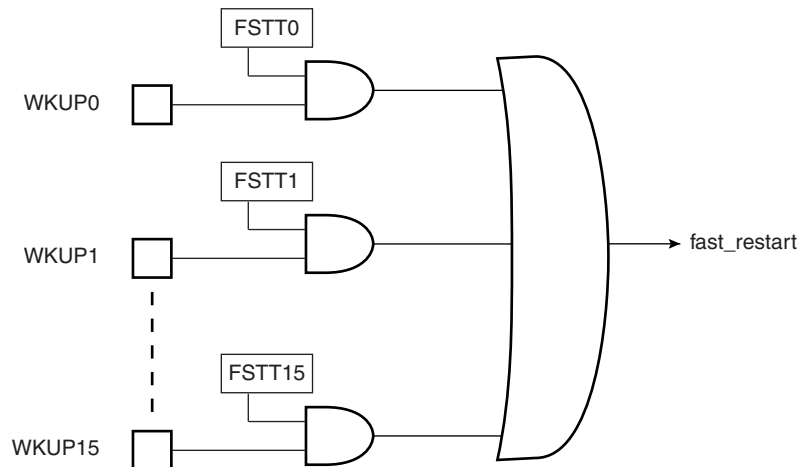

5.5 Voltage Regulator

The AT91SAM7L128/64 embeds a voltage regulator that is managed by the supply controller. This internal regulator is only intended to supply the internal core of AT91SAM7L128/64. It features three different operating modes:

- In normal mode, the voltage regulator consumes less than 30 μA static current and draws 60 mA of output current.
- In deep mode, the current consumption of the voltage regulator is less than 8.5 μA . It can draw up to 1 mA of output current. The default output voltage is 1.80V and the start-up time to reach normal mode is inferior to 400 μs .
- In shutdown mode, the voltage regulator consumes less than 1 μA while its output is driven internally to GND. The default output voltage is 1.80V and the start-up time to reach normal mode is inferior to 400 μs .

Furthermore, in normal and deep modes, the regulator output voltage can be programmed by software with 4 different steps within the range of 1.55V to 1.80V. The default output voltage is 1.80V in both normal and deep modes. The voltage regulator can regulate 1.80V output voltage as long as the input voltage is above 1.95V. Below 1.95V input voltage, the output voltage remains above 1.65V.

Output voltage adjusting ability allows current consumption reduction on VDDCORE and also enables programming a lower voltage when the input voltage is lower than 1.95V.

At 1.55V, the Flash is still functional but with slower read access time. Programming or erasing the Flash is not possible under these conditions. MCK maximum frequency is 25 MHz with VDDCORE at 1.55V (1.45V minimum).

The regulator has an indicator that can be used by the software to show that the output voltage has the correct value (output voltage has reached at least 80% of the typical voltage). This flag is used by the supply controller. This feature is only possible when the voltage regulator is in normal mode at 1.80V.

Adequate output supply decoupling is mandatory for VDDOUT in order to reduce ripple and avoid oscillations. One external 2.2 μF (or 3.3 μF) X7R capacitor must be connected between VDDOUT and GND.

Adequate input supply decoupling is mandatory for VDDIO1 in order to improve startup stability and reduce source voltage drop. The input decoupling capacitor should be placed close to the chip. For example, two capacitors can be used in parallel, 100 nF NPO and 4.7 μ F X7R.

5.6 LCD Power Supply

The AT91SAM7L128/64 embeds an on-chip LCD power supply comprising a regulated charge pump and an adjustable voltage regulator.

The regulated charge pump output delivers 3.6V as long as its input is supplied between 1.8V and 3.6V. The regulated charge pump only requires two external flying capacitors and one external tank capacitor to operate.

Adequate input supply decoupling is mandatory for VDDINLCD in order to improve startup stability and reduce source voltage drop. The input decoupling capacitor should be placed close to the chip.

Current consumption of the charge pump and LCD bias when active is 350 μ A (max case).

The regulated charge pump can be used to supply the LCD voltage regulator or as a 3.6V voltage reference delivering up to 4 mA.

The LCD voltage regulator output voltage is software selectable from 2.4V to 3.4V with 16 levels. Its input should be supplied in the range of 2.5 to 3.6V. The LCD voltage regulator can be supplied by the regulated charge pump output or by an external supply.

When the LCD voltage regulator is not used, its output must be connected to an external source in order to supply the PIOA and PIOB I/O lines.

Figure 5-3 below shows the typical schematics needed:

Figure 5-3. The Charge Pump Supplies the LCD Regulator

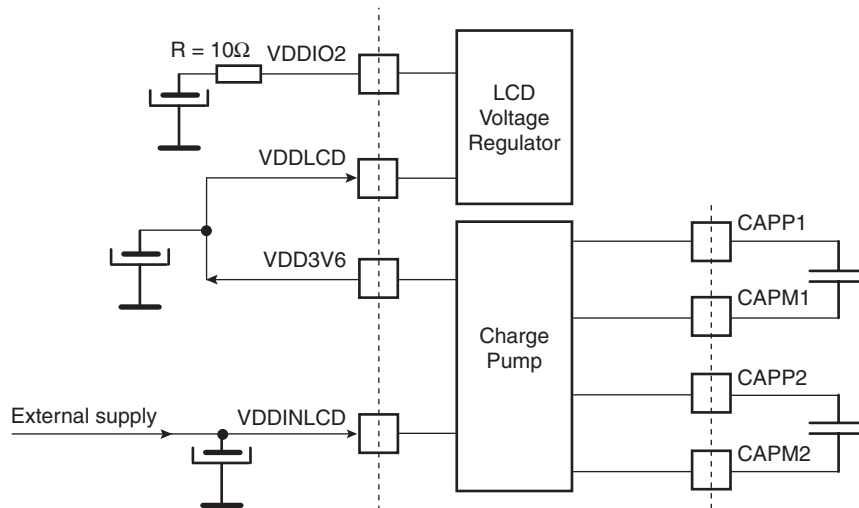
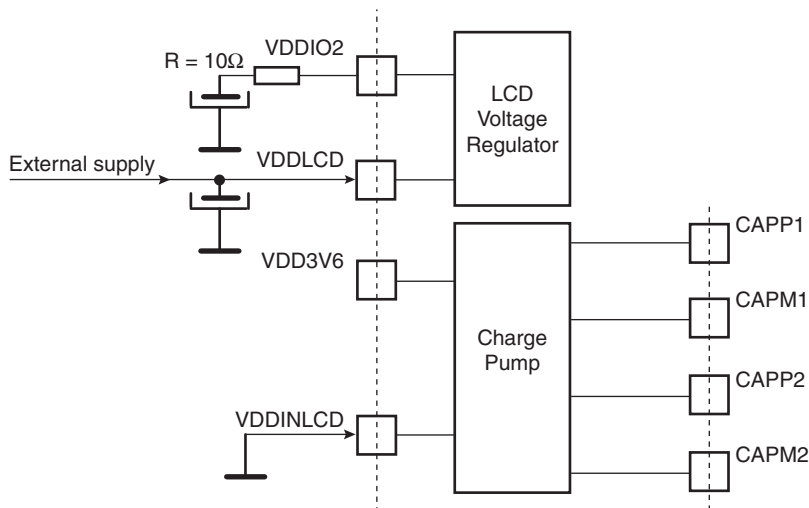
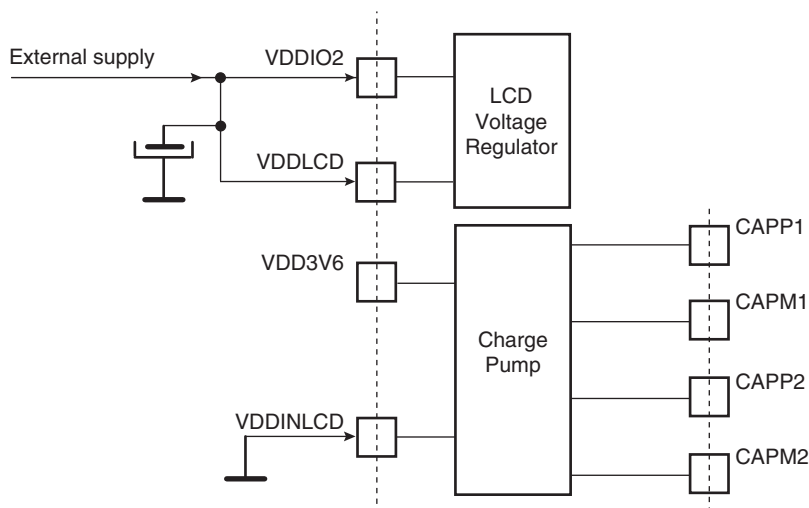

Figure 5-4. The LCD Regulator is Externally Supplied



If the charge pump is not needed, the user can apply an external voltage. See [Figure 5-5](#) below:

Figure 5-5. The Charge Pump and the LCD Regulator are Not Used



Please note that in this topology, switching time enhancement buffers are not available. (Refer [Section 10.13 "Segment LCD Controller"](#).)

5.7 Typical Powering Schematics

The AT91SAM7L128/64 supports a 1.8V-3.6V single supply mode. The internal regulator input connected to the source and its output feeds VDDCORE. Figure 5-6 shows the power schematics to be used.

Figure 5-6. 3.3V System Single Power Supply Schematic

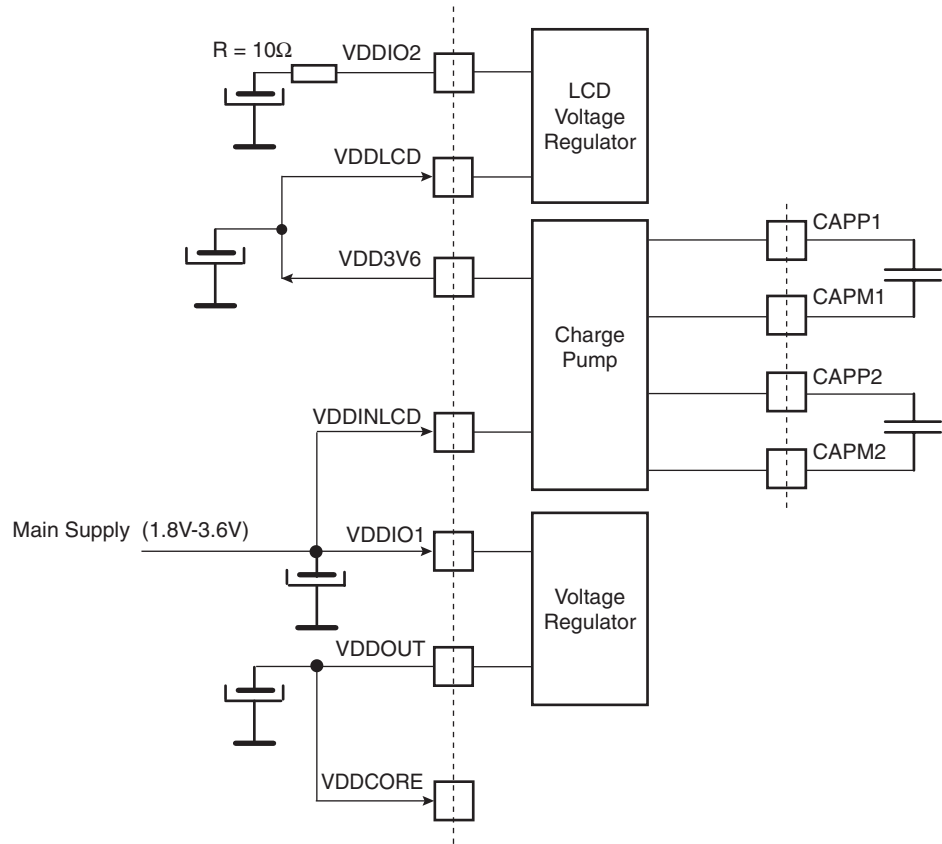

6. I/O Line Considerations

6.1 JTAG Port Pins

TMS, TDI and TCK are schmitt trigger inputs. TMS, TDI and TCK do not integrate a pull-up resistor.

TDO is an output, driven at up to VDDIO, and has no pull-up resistor.

The JTAGSEL pin is used to select the JTAG boundary scan when asserted at a high level. The JTAGSEL pin integrates a permanent pull-down resistor of about 15 k Ω to GND, so that it can be left unconnected for normal operations.

6.2 Test Pin

The TST pin is used for manufacturing test or fast programming mode of the AT91SAM7L128/64 when asserted high. The TST pin integrates a permanent pull-down resistor of about 15 k Ω to GND, so that it can be left unconnected for normal operations.

To enter fast programming mode, the TST and CLKIN pins must be tied high while FWUP is tied low.

6.3 NRST Pin

The NRST pin is bidirectional. It is handled by the on-chip reset controller and can be driven low to provide a reset signal to the external components or asserted low externally to reset the microcontroller. There is no constraint on the length of the reset pulse and the reset controller can guarantee a minimum pulse length.

The NRST pin integrates a permanent pull-up resistor to VDDIO1 of about 100 k Ω .

6.4 NRSTB Pin

The NRSTB pin is input only and enables asynchronous reset of the AT91SAM7L128/64 when asserted low. The NRSTB pin integrates a permanent pull-up resistor of about 15 k Ω . This allows connection of a simple push button on the NRSTB pin as a system-user reset.

In all modes, this pin will reset the chip. It can be used as an external system reset source.

In harsh environments, it is recommended to add an external capacitor (10 nF) between NRSTB and VDDIO1.

NRSTB pin must not be connected to VDDIO1. There must not be an external pull-up on NRSTB.

6.5 ERASE Pin

The ERASE pin is used to reinitialize the Flash content and some of its NVM bits. It integrates a permanent pull-down resistor of about 15 k Ω to GND, so that it can be left unconnected for normal operations.

This pin is debounced by SCLK to improve the glitch tolerance. When the ERASE pin is tied high during less than 100 ms, it is not taken into account. The pin must be tied high during more than 220 ms to perform the reinitialization of the Flash.

6.6 PIO Controller Lines

All the I/O lines; PA0 to PA25, PB0 to PB23, PC0 to PC29 integrate a programmable pull-up resistor. Programming of this pull-up resistor is performed independently for each I/O line through the PIO controllers. All I/Os have input schmitt triggers.

Typical pull-up value is 100 k Ω .

Maximum frequency is:

- 36 MHz under 25 pF of load on PIOC
- 36 MHz under 25 pF of load on PIOA and PIOB

6.7 I/O Line Current Drawing

The PIO lines PC5 to PC8 are high-drive current capable. Each of these I/O lines can drive up to 4 mA permanently. The remaining I/O lines can draw only 2 mA.

Each I/O is designed to achieve very small leakage. However, the total current drawn by all the I/O lines cannot exceed 150 mA.

7. Processor and Architecture

7.1 ARM7TDMI Processor

- RISC processor based on ARMv4T Von Neumann Architecture
 - Runs at up to 36 MHz, providing 0.9 MIPS/MHz
- Two instruction sets
 - ARM® high-performance 32-bit instruction set
 - Thumb high code density 16-bit instruction set
- Three-stage pipeline architecture
 - Instruction Fetch (F)
 - Instruction Decode (D)
 - Execute (E)

7.2 Debug and Test Features

- Integrated embedded in-circuit emulator
 - Two watchpoint units
 - Test access port accessible through a JTAG protocol
 - Debug communication channel
- Debug Unit
 - Two-pin UART
 - Debug communication channel interrupt handling
 - Chip ID Register
- IEEE1149.1 JTAG Boundary-scan on all digital pins

7.3 Memory Controller

- Programmable Bus Arbiter
 - Handles requests from the ARM7TDMI and the Peripheral DMA Controller
- Address decoder provides selection signals for
 - Five internal 1 Mbyte memory areas
 - One 256 Mbyte embedded peripheral area
- Abort Status Registers
 - Source, Type and all parameters of the access leading to an abort are saved
 - Facilitates debug by detection of bad pointers
- Misalignment Detector
 - Alignment checking of all data accesses
 - Abort generation in case of misalignment
- Remap Command
 - Remaps the SRAM in place of the embedded non-volatile memory
 - Allows handling of dynamic exception vectors
 - Peripheral protection against write and/or user access
- Enhanced Embedded Flash Controller

- Embedded Flash interface, up to three programmable wait states
- Prefetch buffer, buffering and anticipating the 16-bit requests, reducing the required wait states
- Key-protected program, erase and lock/unlock sequencer
- Single command for erasing, programming and locking operations
- Interrupt generation in case of forbidden operation

7.4 Peripheral DMA Controller

- Handles data transfer between peripherals and memories
- Eleven channels
 - Two for each USART
 - Two for the Debug Unit
 - Two for the Serial Peripheral Interface
 - Two for the Two Wire Interface
 - One for the Analog-to-digital Converter
- Low bus arbitration overhead
 - One Master Clock cycle needed for a transfer from memory to peripheral
 - Two Master Clock cycles needed for a transfer from peripheral to memory
- Next Pointer management for reducing interrupt latency requirements

8. Memories

- 128 Kbytes of Flash Memory (AT91SAM7L128)
 - Single plane
 - One bank of 512 pages of 256 bytes
 - Fast access time, 15 MHz single-cycle access in Worst Case conditions
 - Page programming time: 4.6 ms, including page auto-erase
 - Page programming without auto-erase: 2.3 ms
 - Full chip erase time: 10 ms
 - 10,000 write cycles, 10-year data retention capability
 - 16 lock bits, each protecting 16 lock regions of 32 pages
 - Protection Mode to secure contents of the Flash
- 64 Kbytes of Flash Memory (AT91SAM7L64)
 - Single plane
 - One bank of 256 pages of 256 bytes
 - Fast access time, 15 MHz single-cycle access in Worst Case conditions
 - Page programming time: 4.6 ms, including page auto-erase
 - Page programming without auto-erase: 2.3 ms
 - Full chip erase time: 10 ms
 - 10,000 write cycles, 10-year data retention capability
 - 8 lock bits, each protecting 8 lock regions of 32 pages
 - Protection Mode to secure contents of the Flash
- 6 Kbytes of Fast SRAM
 - Single-cycle access at full speed
 - 2 Kbytes of Backup SRAM
 - 4 Kbytes of Core SRAM

Figure 8-1. Memory Mapping

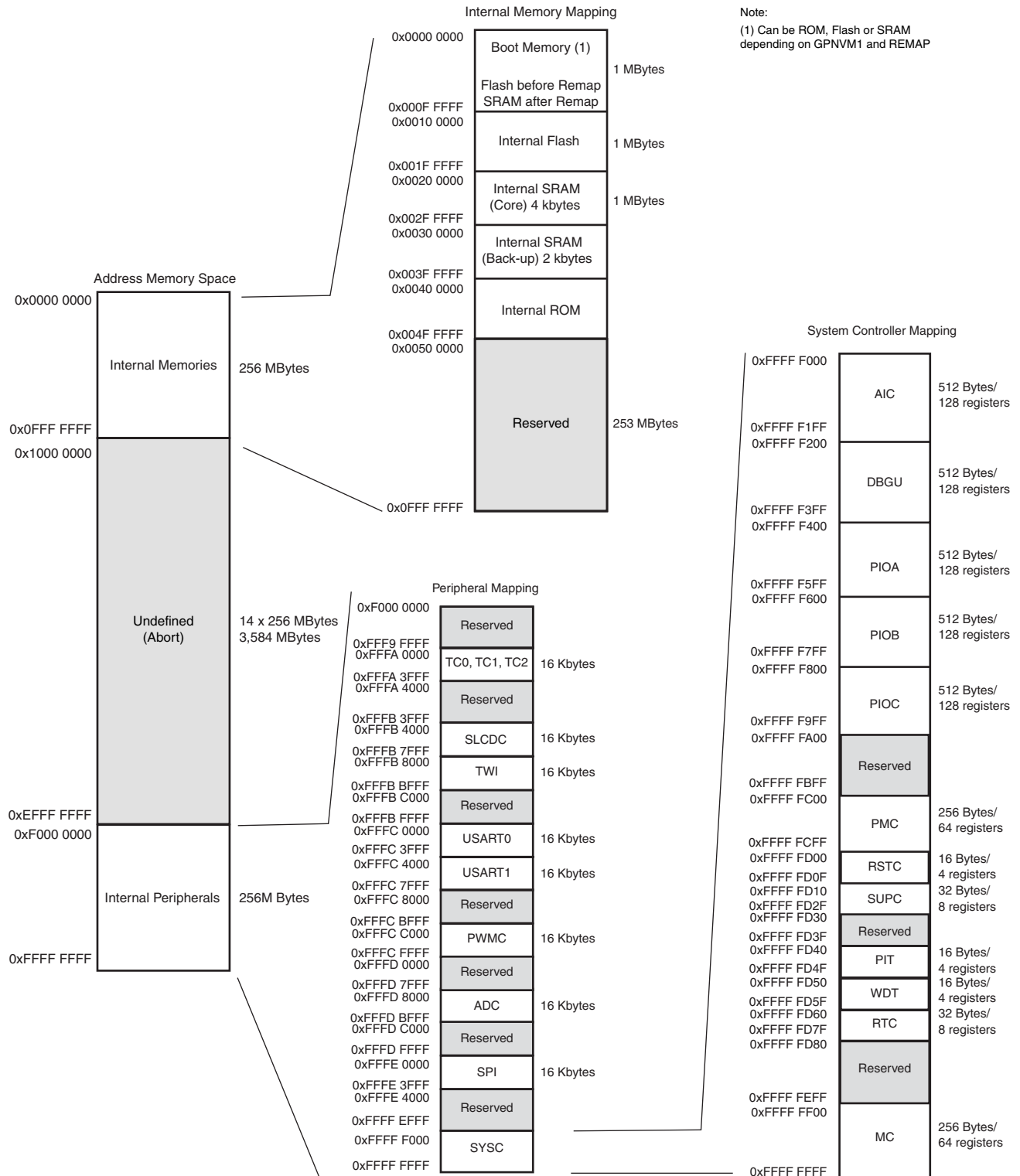

Note:
(1) Can be ROM, Flash or SRAM depending on GPNVM1 and REMAP

8.1 Embedded Memories

8.1.1 Internal Memories

8.1.1.1 Internal SRAM

The AT91SAM7L128/64 embeds a high-speed 4-Kbyte SRAM bank and a 2-Kbyte backup SRAM bank. The backup SRAM is directly supplied on 1.8V-3.6V supply domain.

The 4-Kbyte Core SRAM is supplied by VDDCORE which is connected to the output of the voltage regulator.

After reset and until the Remap Command is performed, the 4-Kbyte Core SRAM is only accessible at address 0x0020 0000. The 2-Kbyte Backup SRAM is accessible at address 0x0030 0000.

After remap, the 4-Kbyte Core SRAM also becomes available at address 0x0.

The user can see the 6 Kbytes of SRAM contiguously at address 0x002F F000.

8.1.1.2 Internal ROM

The AT91SAM7L128/64 embeds an Internal ROM. The ROM is always mapped at address 0x0040 0000. The ROM contains the FFPI and SAM-BA program.

ROM size is 12 Kbytes.

8.1.1.3 Internal Flash

- The AT91SAM7L128 features one bank of 128 Kbytes of Flash.
- The AT91SAM7L64 features one bank of 64 Kbytes of Flash.

At any time, the Flash is mapped to address 0x0010 0000.

A general purpose NVM (GPNVM1) bit is used to boot either on the ROM (default) or from the Flash.

This GPNVM1 bit can be cleared or set respectively through the commands “Clear General-purpose NVM Bit” and “Set General-purpose NVM Bit” of the EEFC User Interface.

Setting the GPNVM Bit 1 selects the boot from the Flash, clearing it selects the boot from the ROM. Asserting ERASE clears the GPNVM Bit 1 and thus selects the boot from the ROM by default.

Figure 8-2. Internal Memory Mapping with GPNVM Bit 1 = 0 (default)

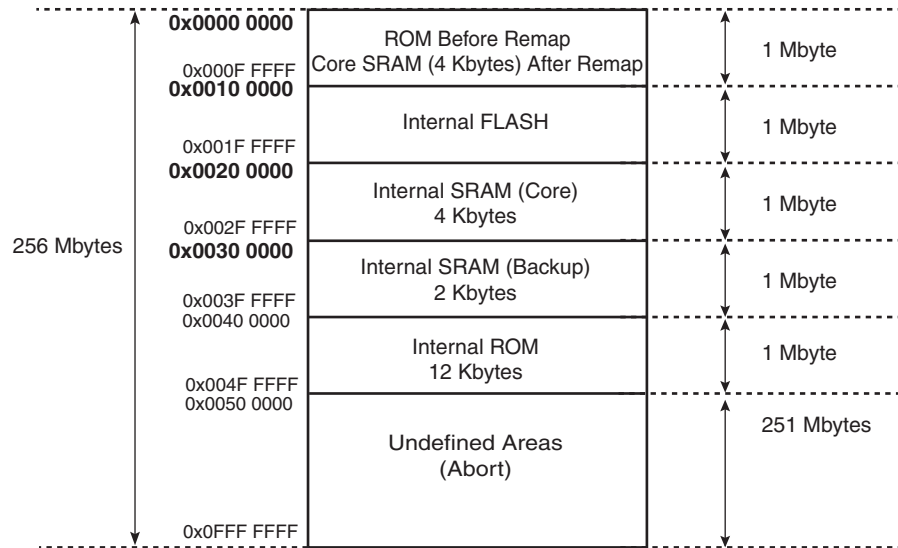
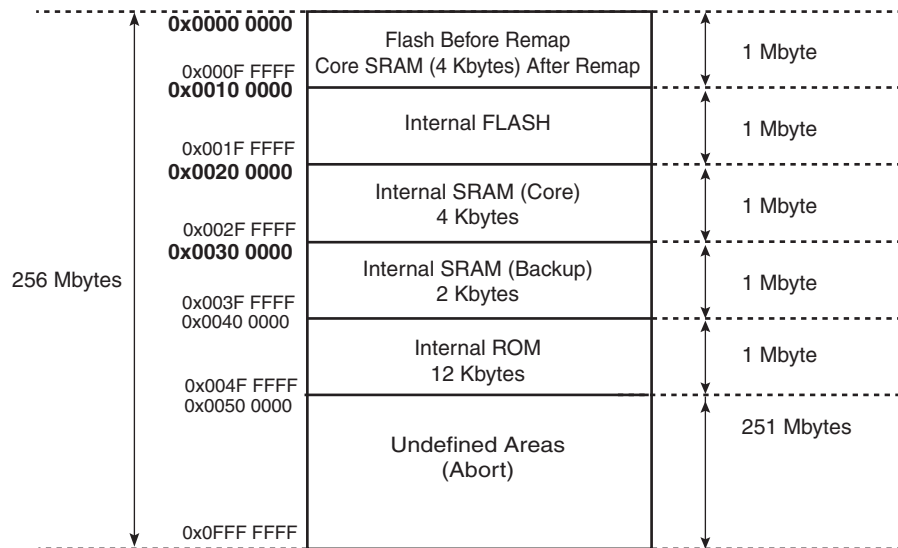

Figure 8-3. Internal Memory Mapping with GPNVM Bit 1 = 1



8.1.2 Embedded Flash

8.1.2.1 Flash Overview

- The Flash of the AT91SAM7L128 is organized in 512 pages (single plane) of 256 bytes.
- The Flash of the AT91SAM7L64 is organized in 256 pages (single plane) of 256 bytes.

The Flash contains a 128-byte write buffer, accessible through a 32-bit interface.

8.1.2.2 Flash Power Supply

The Flash is supplied by VDDCORE through a power switch controlled by the Supply Controller.

8.1.2.3 *Enhanced Embedded Flash Controller*

The Enhanced Embedded Flash Controller (EEFC) manages accesses performed by the masters of the system. It enables reading the Flash and writing the write buffer. It also contains a User Interface, mapped within the Memory Controller on the APB.

The Enhanced Embedded Flash Controller ensures the interface of the Flash block with the 32-bit internal bus. Its 128-bit wide memory interface increases performance. It also manages the programming, erasing, locking and unlocking sequences of the Flash using a full set of commands. One of the commands returns the embedded Flash descriptor definition that informs the system about the Flash organization, thus making the software generic.

8.1.2.4 *Lock Regions*

The AT91SAM7L128 Embedded Flash Controller manages 16 lock bits to protect 16 regions of the flash against inadvertent flash erasing or programming commands. The AT91SAM7L128 contains 16 lock regions and each lock region contains 32 pages of 256 bytes. Each lock region has a size of 8 Kbytes.

The AT91SAM7L64 Embedded Flash Controller manages 8 lock bits to protect 8 regions of the flash against inadvertent flash erasing or programming commands. The AT91SAM7L64 contains 8 lock regions and each lock region contains 32 pages of 256 bytes. Each lock region has a size of 8 Kbytes.

If a locked-region's erase or program command occurs, the command is aborted and the EEFC triggers an interrupt.

The 16 NVM bits are software programmable through the EEFC User Interface. The command "Set Lock Bit" enables the protection. The command "Clear Lock Bit" unlocks the lock region.

Asserting the ERASE pin clears the lock bits, thus unlocking the entire Flash.

8.1.2.5 *Security Bit Feature*

The AT91SAM7L128/64 features a security bit, based on a specific General Purpose NVM bit (GPNVM bit 0). When the security is enabled, any access to the Flash, either through the ICE interface or through the Fast Flash Programming Interface, is forbidden. This ensures the confidentiality of the code programmed in the Flash.

This security bit can only be enabled, through the command "Set General Purpose NVM Bit 0" of the EEFC User Interface. Disabling the security bit can only be achieved by asserting the ERASE pin at 1, and after a full Flash erase is performed. When the security bit is deactivated, all accesses to the Flash are permitted.

It is important to note that the assertion of the ERASE pin should always be longer than 200 ms.

As the ERASE pin integrates a permanent pull-down, it can be left unconnected during normal operation. However, it is safer to connect it directly to GND for the final application.

8.1.2.6 *Calibration Bits*

NVM bits are used to calibrate the brownout detector and the voltage regulator. These bits are factory configured and cannot be changed by the user. The ERASE pin has no effect on the calibration bits.

8.1.2.7 GPNVM Bits

The AT91SAM7L128/64 features two GPNVM bits that can be cleared or set respectively through the commands “Clear GPNVM Bit” and “Set GPNVM Bit” of the EEFC User Interface..

Table 8-1. General-purpose Non-volatile Memory Bits

GPNVMBit[#]	Function
0	Security bit
1	Boot mode selection

8.1.3 Fast Flash Programming Interface

The Fast Flash Programming Interface allows programming the device through either a serial JTAG interface or through a multiplexed fully-handshaked parallel port. It allows gang programming with market-standard industrial programmers.

The FFPI supports read, page program, page erase, full erase, lock, unlock and protect commands.

The Fast Flash Programming Interface is enabled and the Fast Programming Mode is entered when TST and CLKIN are tied high while FWUP is tied low.

- The Flash of the AT91SAM7L128 is organized in 512 pages of 256 bytes (single plane).
- The Flash of the AT91SAM7L64 is organized in 256 pages of 256 bytes (single plane).

The Flash contains a 128-byte write buffer, accessible through a 32-bit interface.

8.1.4 SAM-BA Boot

The SAM-BA Boot is a default Boot Program which provides an easy way to program in-situ the on-chip Flash memory.

The SAM-BA Boot Assistant supports serial communication via the DBGU.

The SAM-BA Boot provides an interface with SAM-BA Graphic User Interface (GUI).

The SAM-BA Boot resides in ROM and is mapped at address 0x0 when GPNVM bit 1 is set to 0.

9. System Controller

The System Controller manages all vital blocks of the microcontroller, interrupts, clocks, power, time, debug and reset.

The System Controller Block Diagram is shown in [Figure 9-1 on page 30](#).

9.1 System Controller Mapping

The System Controller peripherals are all mapped to the highest 4 Kbytes of address space, between addresses 0xFFFF F000 and 0xFFFF FFFF. [Figure 8-1 on page 24](#) shows the mapping of the System Controller. Note that the Memory Controller configuration user interface is also mapped within this address space

Figure 9-1. System Controller Block Diagram

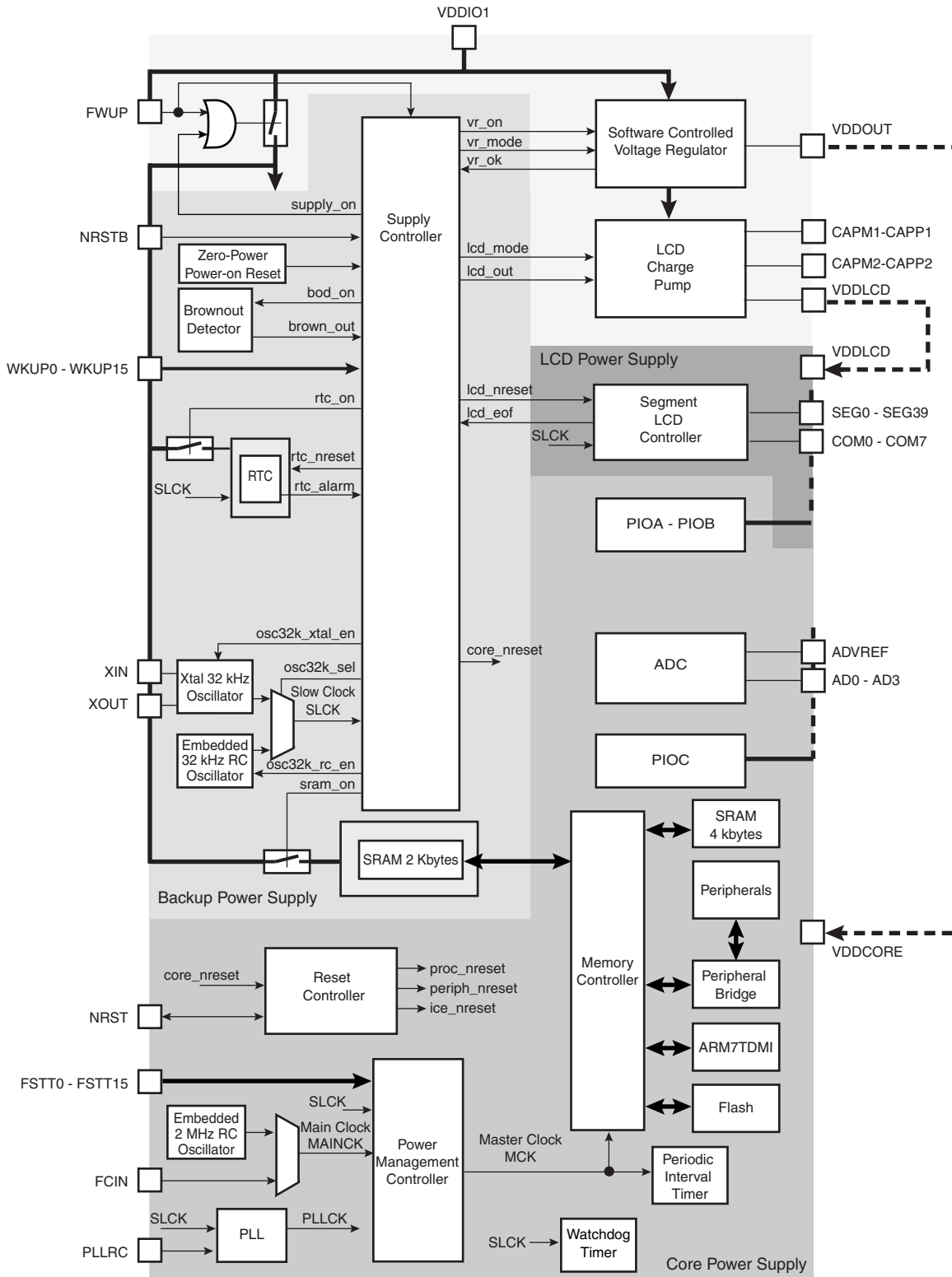

9.2 Supply Controller (SUPC)

The Supply Controller controls the power supplies of each section of the product:

- the processor and the peripherals
- the Flash memory
- the backup SRAM
- the LCD controller, the charge pump and the LCD voltage regulator
- the Real Time Clock

The Supply Controller has its own reset circuitry and is clocked by the 32 kHz Slow clock generator.

The reset circuitry is based on the NRSTB pin, a zero-power power-on reset cell and a brownout detector cell. The zero-power power-on reset allows the Supply Controller to start properly, while the software-programmable brownout detector allows detection of either a battery discharge or main voltage loss.

The Slow Clock generator is based on a 32 kHz crystal oscillator and an embedded 32 kHz RC oscillator. The Slow Clock defaults to the RC oscillator, but the software can enable the crystal oscillator and select it as the Slow Clock source.

The Supply Controller starts up the device by sequentially enabling the internal power switches and the Voltage Regulator, then it generates the proper reset signals to the core power supply.

It also enables to set the system in different low power modes and to wake it up from a wide range of events.

9.3 Reset Controller

- Based on one power-on reset cell and a brownout detector
- Status of the last reset; either power-up reset, software reset, user reset, watchdog reset, brownout reset
- Controls the internal resets and the NRST pin output
- Allows to shape a signal on the NRST line, guaranteeing that the length of the pulse meets any requirement.

9.3.1 Brownout Detector (BOD) and Power-on Reset

The AT91SAM7L128/64 embeds one zero-power power-on reset and a brownout detection circuit. Both monitor VDDIO1.

The zero-power power-on reset circuit is always active. It provides an internal reset signal to the AT91SAM7L128/64 for power-on and power-off operations and ensures a proper reset for the Supply Controller.

The brownout detection circuit is disabled by default and can be enabled by software. It monitors VDDIO1.

The brownout detection circuit is factory calibrated.

The threshold is programmable via software. It can be selected from 1.9V to 3.4V with 100 mV steps. It can be programmed to generate either a wake-up alarm or a reset.

It can be used to wake up the chip from backup mode if the supply drops below a selected threshold (to warn the end user about a discharged battery for example) and to reset the chip when the voltage is too low.

BOD current consumption is 25 μ A, typically.

To decrease current consumption, the software can disable the brownout detector, especially in low-power mode.

The software can also configure the BOD in “switched” mode. In this mode, an internal state machine switches on and off periodically and stores the output of the BOD.

This decreases the current consumption (inferior to 2 μ A) while the detection is still active. This feature is suitable in low-power mode where voltage detection is still needed.

9.4 Clock Generator

The clock generator embeds one low-power RC oscillator, one fast RC oscillator, one crystal oscillator and one PLL with the following characteristics:

- RC Oscillator ranges between 22 kHz and 42 kHz
- Fast RC Oscillator ranges between 1.5 MHz and 2.5 MHz
- Crystal Oscillator at 32 kHz (can be bypassed)
- PLL output ranges between 18 MHz and 47 MHz

It provides SLCK, MAINCK and PLLCK.

The Supply Controller selects between the internal RC oscillator and the 32 kHz crystal oscillator. The unused oscillator is disabled so that power consumption is optimized.

The 2 MHz Fast RC oscillator is the default selected clock (MAINCK) which is used at start-up . The user can select an external clock (CLKIN) through software.

The PLL needs an external RC filter and starts up in a very short time (inferior to 1 ms).

Figure 9-2. Clock Generator Block Diagram

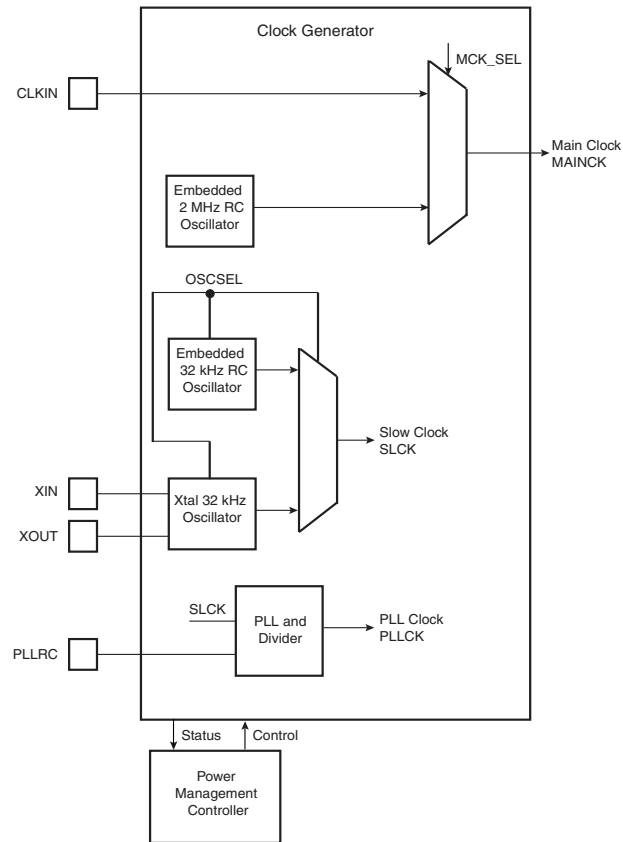

9.5 Power Management Controller

The Power Management Controller uses the clock generator outputs to provide:

- The Processor Clock PCK
- The Master Clock MCK
- All the peripheral clocks, independently controllable
- Three programmable clock outputs PCKx

The Master Clock (MCK) is programmable from a few hundred Hz to the maximum operating frequency of the device.

The Processor Clock (PCK) switches off when entering processor idle mode, thus allowing reduced power consumption while waiting for an interrupt.

The LCD Controller clock is SCLK.

Figure 9-3. Power Management Controller Block Diagram

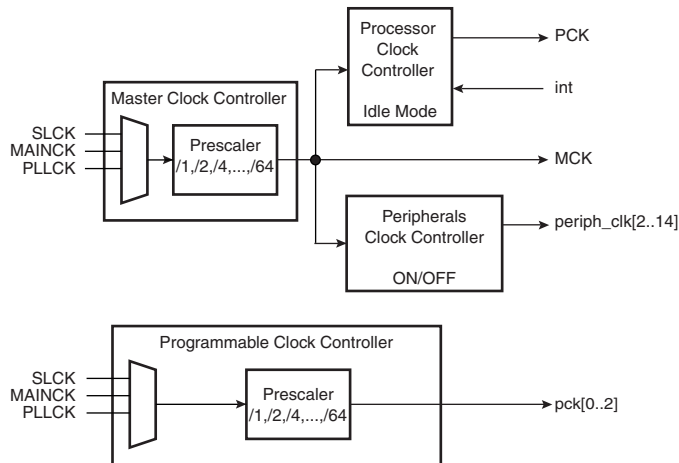

9.6 Advanced Interrupt Controller

- Controls the interrupt lines (nIRQ and nFIQ) of an ARM Processor
- Individually maskable and vectored interrupt sources
 - Source 0 is reserved for the Fast Interrupt Input (FIQ)
 - Source 1 is reserved for system peripherals (RTC, PIT, EFC, PMC, DBGU, etc.)
 - Other sources control the peripheral interrupts or external interrupts
 - Programmable edge-triggered or level-sensitive internal sources
 - Programmable positive/negative edge-triggered or high/low level-sensitive external sources
- 8-level Priority Controller
 - Drives the normal interrupt nIRQ of the processor
 - Handles priority of the interrupt sources
 - Higher priority interrupts can be served during service of lower priority interrupt
- Vectoring
 - Optimizes interrupt service routine branch and execution
 - One 32-bit vector register per interrupt source
 - Interrupt vector register reads the corresponding current interrupt vector
- Protect Mode
 - Easy debugging by preventing automatic operations
- Fast Forcing
 - Permits redirecting any interrupt source on the fast interrupt
- General Interrupt Mask
 - Provides processor synchronization on events without triggering an interrupt

9.7 Debug Unit

- Comprises:
 - One two-pin UART
 - One Interface for the Debug Communication Channel (DCC) support

- One set of Chip ID Registers
- One Interface providing ICE Access Prevention
- Two-pin UART
 - USART-compatible User Interface
 - Programmable Baud Rate Generator
 - Parity, Framing and Overrun Error
 - Automatic Echo, Local Loopback and Remote Loopback Channel Modes
- Debug Communication Channel Support
 - Offers visibility of COMMRX and COMMTX signals from the ARM Processor
- Chip ID Registers
 - Identification of the device revision, sizes of the embedded memories, set of peripherals
 - Chip ID is 0x2733 0740 (VERSION 0) for AT91SAM7L128
 - Chip ID is 0x2733 0540 (VERSION 0) for AT91SAM7L64

9.8 Period Interval Timer

- 20-bit programmable counter plus 12-bit interval counter

9.9 Watchdog Timer

- 12-bit key-protected Programmable Counter running on prescaled SLCK
- Provides reset or interrupt signals to the system
- Counter may be stopped while the processor is in debug state or in idle mode

9.10 Real-time Clock

- Two Hundred Year Calendar
- Programmable Periodic Interrupt
- Time, Date and Alarm 32-bit Parallel Load

9.11 PIO Controllers

- Three PIO Controllers.
 - PIO A controls 26 I/O lines
 - PIO B controls 24 I/O lines
 - PIO C controls 30 I/O lines
- Fully programmable through set/clear registers
- Multiplexing of two peripheral functions per I/O line
- For each I/O line (whether assigned to a peripheral or used as general-purpose I/O)
 - Input change interrupt
 - Half a clock period glitch filter
 - Multi-drive option enables driving in open drain
 - Programmable pull-up on each I/O line
 - Pin data status register, supplies visibility of the level on the pin at any time
- Synchronous output, provides Set and Clear of several I/O lines in a single write



10. Peripherals

10.1 User Interface

The User Peripherals are mapped in the 256 MBytes of the address space between 0xF000 0000 and 0xFFFF EFFF. Each peripheral is allocated 16 Kbytes of address space.

A complete memory map is presented in [Figure 8-1 on page 24](#).

10.2 Peripheral Identifiers

The AT91SAM7L128/64 embeds a wide range of peripherals. [Table 10-1](#) defines the Peripheral Identifiers of the AT91SAM7L128/64. Unique peripheral identifiers are defined for both the Advanced Interrupt Controller and the Power Management Controller.

Table 10-1. Peripheral Identifiers

Peripheral ID	Peripheral Mnemonic	Peripheral Name	External Interrupt
0	AIC	Advanced Interrupt Controller	FIQ
1	SYSIRQ ⁽¹⁾	System Interrupt	
2	PIOA	Parallel I/O Controller A	
3	PIOB	Parallel I/O Controller B	
4	PIOC	Parallel I/O Controller C	
5	SPI	Serial Peripheral Interface	
6	US0	USART 0	
7	US1	USART 1	
8	Reserved		
9	TWI	Two-wire Interface	
10	PWMC	PWM Controller	
11	SLCDC	Segmented LCD Controller	
12	TC0	Timer/Counter 0	
13	TC1	Timer/Counter 1	
14	TC2	Timer/Counter 2	
15	ADC ⁽¹⁾	Analog-to Digital Converter	
16 - 29	Reserved		
30	AIC	Advanced Interrupt Controller	IRQ0
31	AIC	Advanced Interrupt Controller	IRQ1

Note: 1. Setting SYSIRQ and ADC bits in the clock set/clear registers of the PMC has no effect. The System Controller and ADC are continuously clocked. The ADC clock is automatically started for the first conversion. In Sleep Mode the ADC clock is automatically stopped after each conversion.

10.3 Peripheral Multiplexing on PIO Lines

The AT91SAM7L128/64 features three PIO controllers, PIOA, PIOB and PIOC, that multiplex the I/O lines of the peripheral set.

PIO Controller A, B and C control respectively 26, 24 and 30 lines. Each line can be assigned to one of two peripheral functions, A or B.

[Table 10-2 on page 38](#) defines how the I/O lines of the peripherals A, B or the analog inputs are multiplexed on the PIO Controller A, B and C. The two columns “Function” and “Comments” have been inserted for the user’s own comments; they may be used to track how pins are defined in an application.

Note that some peripheral functions that are output only may be duplicated in the table.

At reset, all I/O lines are automatically configured as input with the programmable pull-up enabled, so that the device is maintained in a static state as soon as a reset is detected.



10.4 PIO Controller A Multiplexing

Table 10-2. Multiplexing on PIO Controller A

PIO Controller A				Application Usage	
I/O Line	Peripheral A	Peripheral B	Extra Function	Function	Comments
PA0			COM0		
PA1			COM1		
PA2			COM2		
PA3			COM3		
PA4			COM4		
PA5			COM5		
PA6			SEG0		
PA7			SEG1		
PA8			SEG2		
PA9			SEG3		
PA10			SEG4		
PA11			SEG5		
PA12			SEG6		
PA13			SEG7		
PA14			SEG8		
PA15			SEG9		
PA16			SEG10		
PA17			SEG11		
PA18			SEG12		
PA19			SEG13		
PA20			SEG14		
PA21			SEG15		
PA22			SEG16		
PA23			SEG17		
PA24			SEG18		
PA25			SEG19		

10.5 PIO Controller B Multiplexing

Table 10-3. Multiplexing on PIO Controller B

PIO Controller B				Application Usage	
I/O Line	Peripheral A	Peripheral B	Extra Function	Function	Comments
PB0			SEG20		
PB1			SEG21		
PB2			SEG22		
PB3			SEG23		
PB4			SEG24		
PB5			SEG25		
PB6			SEG26		
PB7			SEG27		
PB8			SEG28		
PB9			SEG29		
PB10			SEG30		
PB11			SEG31		
PB12	NPCS3		SEG32		
PB13	NPCS2		SEG33		
PB14	NPCS1		SEG34		
PB15	RTS1		SEG35		
PB16	RTS0		SEG36		
PB17	DTR1		SEG37		
PB18	PWM0		SEG38		
PB19	PWM1		SEG39		
PB20	PWM2		COM6		
PB21	PWM3		COM7		
PB22	NPCS1	PCK1	COM8		
PB23	PCK0	NPCS3	COM9		

10.6 PIO Controller C Multiplexing

Table 10-4. Multiplexing on PIO Controller C

PIO Controller C				Application Usage	
I/O Line	Peripheral A	Peripheral B	Extra Functions	Function	Comments
PC0	CTS1	PWM2	PGMEN0/WKUP0 ⁽¹⁾⁽²⁾		
PC1	DCD1	TIOA2	PGMEN1/WKUP1 ⁽¹⁾⁽²⁾		
PC2	DTR1	TIOB2	PGMEN2/WKUP2 ⁽¹⁾⁽²⁾		
PC3	DSR1	TCLK1	PGMNCMD/WKUP3 ⁽¹⁾⁽²⁾		
PC4	RI1	TCLK2	PGMRDY/WKUP4 ⁽¹⁾⁽²⁾		
PC5	IRQ1	NPCS2	PGMNOE/WKUP5 ⁽¹⁾⁽²⁾		
PC6	NPCS1	PCK2	PGMNVALID/WKUP6 ⁽¹⁾⁽²⁾		
PC7	PWM0	TIOA0	PGMMO/High drive		
PC8	PWM1	TIOB0	PGMM1/High drive		
PC9	PWM2	SCK0	PGMM2/High drive		
PC10	TWD	NPCS3	PGMM3/High drive		
PC11	TWCK	TCLK0	PGMD0/WKUP7 ⁽¹⁾⁽²⁾		
PC12	RXD0	NPCS3	PGMD1/WKUP8 ⁽¹⁾⁽²⁾		
PC13	TXD0	PCK0	PGMD2/WKUP9 ⁽¹⁾⁽²⁾		
PC14	RTS0	ADTRG	PGMD3/WKUP10 ⁽¹⁾⁽²⁾		
PC15	CTS0	PWM3	PGMD4/WKUP11 ⁽¹⁾⁽²⁾		
PC16	DRXD	NPCS1	PGMD5		
PC17	DTXD	NPCS2	PGMD6		
PC18	NPCS0	PWM0	PGMD7		
PC19	MISO	PWM1	PGMD8		
PC20	MOSI	PWM2	PGMD9		
PC21	SPCK	PWM3	PGMD10		
PC22	NPCS3	TIOA1	PGMD11		
PC23	PCK0	TIOB1	PGMD12		
PC24	RXD1	PCK1	PGMD13		
PC25	TXD1	PCK2	PGMD14		
PC26	RTS0	FIQ	PGMD15/WKUP12 ⁽¹⁾⁽²⁾		
PC27	NPCS2	IRQ0	WKUP13 ⁽¹⁾⁽²⁾		
PC28	SCK1	PWM0	WKUP14 ⁽¹⁾⁽²⁾		
PC29	RTS1	PWM1	WKUP15 ⁽¹⁾⁽²⁾		

- Notes: 1. Wake-Up source in Backup mode (managed by the SUPC).
 2. Fast Start-Up source in Wait mode (managed by the PMC).

10.7 Serial Peripheral Interface

- Supports communication with external serial devices
 - Four chip selects with external decoder allow communication with up to 15 peripherals
 - Serial memories, such as DataFlash® and 3-wire EEPROMs
 - Serial peripherals, such as ADCs, DACs, LCD Controllers, CAN Controllers and Sensors
 - External co-processors
- Master or slave serial peripheral bus interface
 - 8- to 16-bit programmable data length per chip select
 - Programmable phase and polarity per chip select
 - Programmable transfer delays per chip select, between consecutive transfers and between clock and data
 - Programmable delay between consecutive transfers
 - Selectable mode fault detection
 - Maximum frequency at up to Master Clock

10.8 Two Wire Interface

- Master, Multi-Master and Slave Mode Operation
- Compatibility with Atmel two-wire interface, serial memory and I²C compatible devices
- One, two or three bytes for slave address
- Sequential read/write operations
- Bit Rate: Up to 400 kbit/s
- General Call Supported in Slave Mode
- Connecting to PDC channel capabilities optimizes data transfers in Master Mode only
 - One channel for the receiver, one channel for the transmitter
 - Next buffer support

10.9 USART

- Programmable Baud Rate Generator
- 5- to 9-bit full-duplex synchronous or asynchronous serial communications
 - 1, 1.5 or 2 stop bits in Asynchronous Mode
 - 1 or 2 stop bits in Synchronous Mode
 - Parity generation and error detection
 - Framing error detection, overrun error detection
 - MSB or LSB first
 - Optional break generation and detection
 - By 8 or by 16 over-sampling receiver frequency
 - Hardware handshaking RTS - CTS
 - Modem Signals Management DTR-DSR-DCD-RI on USART1
 - Receiver time-out and transmitter timeguard

- Multi-drop Mode with address generation and detection
- Optional Manchester Encoding
- RS485 with driver control signal
- ISO7816, T = 0 or T = 1 Protocols for interfacing with smart cards
 - NACK handling, error counter with repetition and iteration limit
- IrDA modulation and demodulation
 - Communication at up to 115.2 Kbps
- Test Modes
 - Remote Loopback, Local Loopback, Automatic Echo

10.10 Timer Counter

- Three 16-bit Timer Counter Channels
 - Three output compare or two input capture
- Wide range of functions including:
 - Frequency measurement
 - Event counting
 - Interval measurement
 - Pulse generation
 - Delay timing
 - Pulse Width Modulation
 - Up/down capabilities
- Each channel is user-configurable and contains:
 - Three external clock inputs
- Five internal clock inputs, as defined in [Table 10-5](#)

Table 10-5. Timer Counter Clock Assignment

TC Clock input	Clock
TIMER_CLOCK1	MCK/2
TIMER_CLOCK2	MCK/8
TIMER_CLOCK3	MCK/32
TIMER_CLOCK4	MCK/128
TIMER_CLOCK5	MCK/1024

- Two multi-purpose input/output signals
- Two global registers that act on all three TC channels

10.11 PWM Controller

- Four channels, one 16-bit counter per channel
- Common clock generator, providing thirteen different clocks
 - One Modulo n counter providing eleven clocks
 - Two independent linear dividers working on modulo n counter outputs

- Independent channel programming
 - Independent enable/disable commands
 - Independent clock selection
 - Independent period and duty cycle, with double buffering
 - Programmable selection of the output waveform polarity
 - Programmable center or left aligned output waveform

10.12 Analog-to-Digital Converter

- 4-channel ADC supplied by the internal voltage regulator
- 10-bit 460 Ksamples/sec. or 8-bit 660 Ksamples/sec. Successive Approximation Register ADC
- ± 2 LSB Integral Non Linearity, ± 1 LSB Differential Non Linearity
- Integrated 4-to-1 multiplexer
- External voltage reference for better accuracy on low voltage inputs
- Individual enable and disable of each channel
- Multiple trigger sources
 - Hardware or software trigger
 - External trigger pin
 - Timer Counter 0 to 2 outputs TIOA0 to TIOA2 trigger
- Sleep Mode and conversion sequencer
 - Automatic wakeup on trigger and back to sleep mode after conversions of all enabled channels

10.13 Segment LCD Controller

The Segment LCD Controller/driver is intended for monochrome passive liquid crystal display (LCD) with up to 10 common terminals and up to 40 segment terminals.

- 40 segments and 10 common terminals display capacity
- Support static, 1/2, 1/3, 1/4, 1/5, 1/6, 1/7, 1/8, 1/9 and 1/10 Duty
- Support static, 1/2, 1/3, 1/4 Bias
- Power-save mode display
- Software-selectable low-power waveform capability
- Flexible frame frequency selection
- Segment and common pins, not needed for driving the display, can be used as ordinary I/O pins
- Switching time enhancement internal buffers

11. Package Drawings

Figure 11-1. 128-lead LQFP Package Drawing

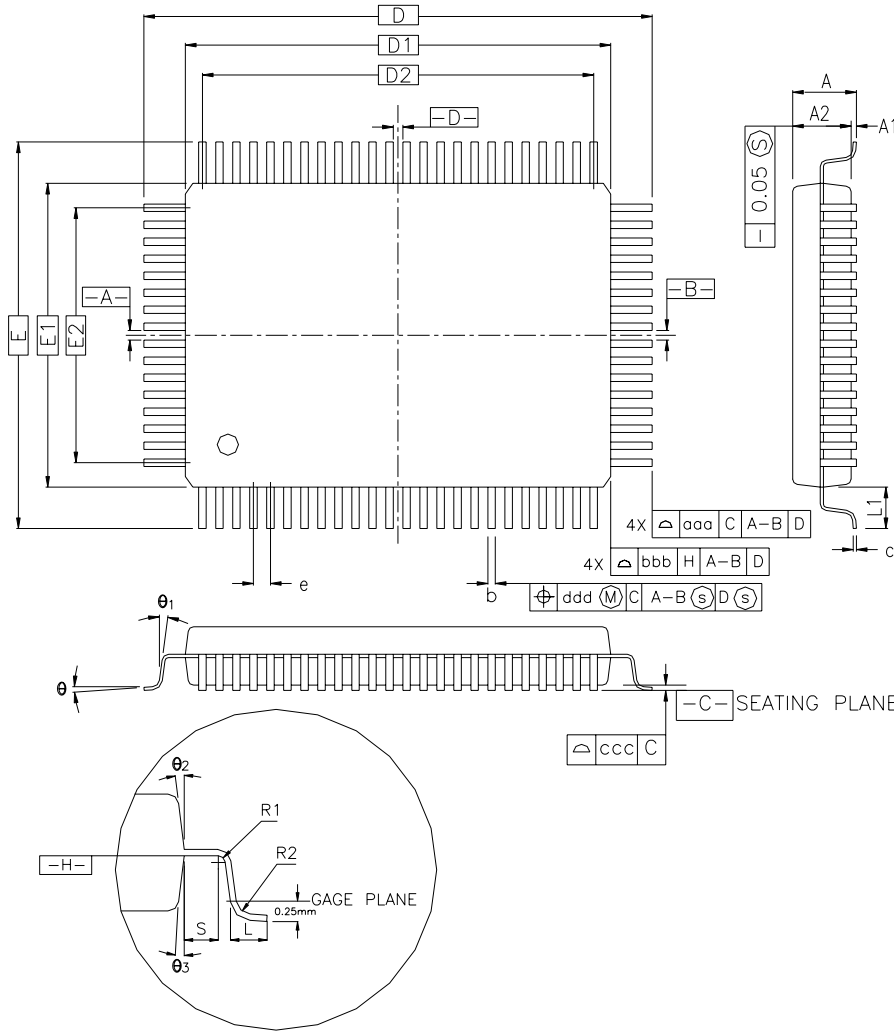

CONTROL DIMENSIONS ARE IN MILLIMETERS.

SYMBOL	MILLIMETER			INCH		
	MIN.	NOM.	MAX.	MIN.	NOM.	MAX.
A	—	—	1.60	—	—	0.063
A1	0.05	—	0.15	0.002	—	0.006
A2	1.35	1.40	1.45	0.053	0.055	0.057
D	22.00 BSC.			0.866 BSC.		
D1	20.00 BSC.			0.787 BSC.		
E	16.00 BSC.			0.630 BSC.		
E1	14.00 BSC.			0.551 BSC.		
R2	0.08	—	0.20	0.003	—	0.008
R1	0.08	—	—	0.003	—	—
θ	0°	3.5°	7°	0°	3.5°	7°
θ_1	0°	—	—	0°	—	—
θ_2	11°	12°	13°	11°	12°	13°
θ_3	11°	12°	13°	11°	12°	13°
c	0.09	—	0.20	0.004	—	0.008
L	0.45	0.60	0.75	0.018	0.024	0.030
L ₁	1.00 REF			0.039 REF		
S	0.20	—	—	0.008	—	—
b	0.17	0.20	0.27	0.007	0.008	0.011
e	0.50 BSC.			0.020 BSC.		
D2	18.50			0.728		
E2	12.50			0.492		
TOLERANCES OF FORM AND POSITION						
aaa	0.20			0.008		
bbb	0.20			0.008		
ccc	0.08			0.003		
ddd	0.08			0.003		

Table 11-1. Device and LQFP Package Maximum Weight

AT91SAM7L128/64	800	mg
-----------------	-----	----

Table 11-2. Package Reference

JEDEC Drawing Reference	MS-026
JESD97 Classification	e3

Table 11-3. LQFP Package Characteristics

Moisture Sensitivity Level	3
----------------------------	---

Figure 11-2. 144-lead LFBGA Package Drawing

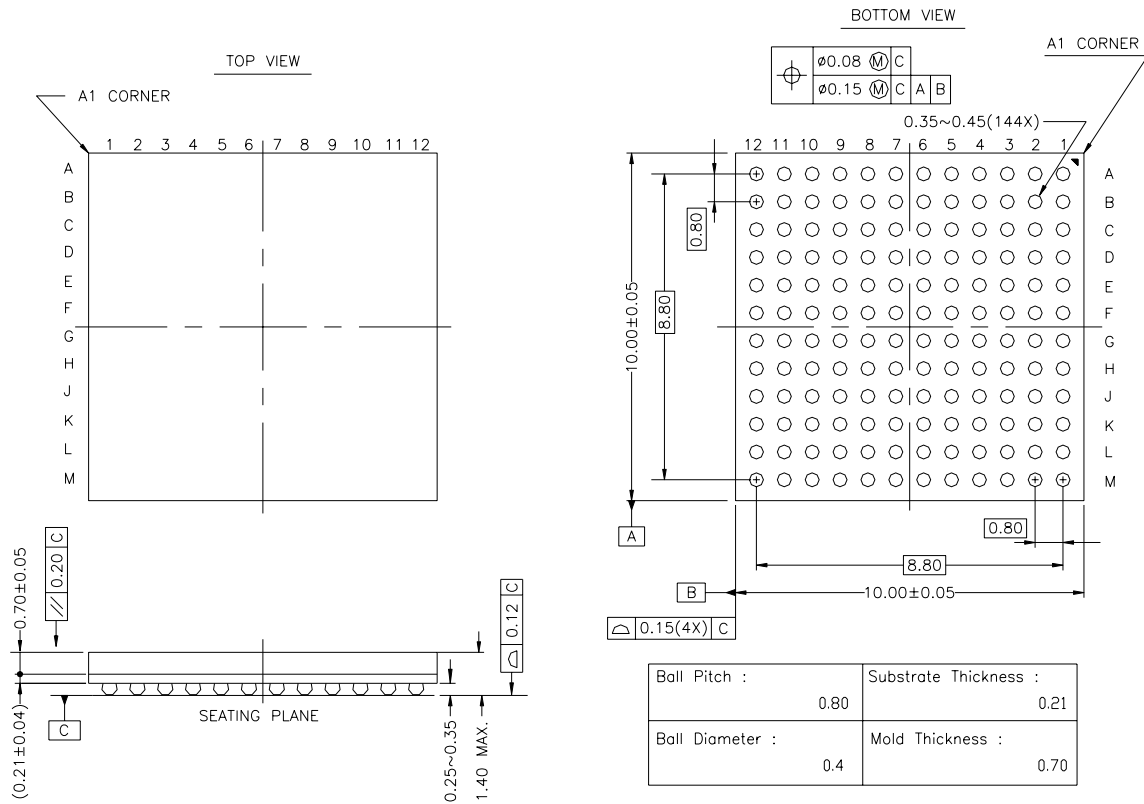

All dimensions are in mm

Table 11-4. Device and LFBGA Package Maximum Weight

AT91SAM7L128/64	mg
-----------------	----

Table 11-5. Package Reference

JEDEC Drawing Reference	MS-026
JESD97 Classification	e1

Table 11-6. LFBGA Package Characteristics

Moisture Sensitivity Level	3
----------------------------	---

This package respects the recommendations of the NEMI User Group.

12. Ordering Information

Table 12-1. Ordering Information

Ordering Code	Package	Package Type	Temperature Operating Range
AT91SAM7L128-AU	LQFP128	Green	Industrial (-40°C to 85°C)
AT91SAM7L64-AU	LQFP128	Green	Industrial (-40°C to 85°C)
AT91SAM7L128-CU	LFBGA144	Green	Industrial (-40°C to 85°C)
AT91SAM7L64-CU	LFBGA144	Green	Industrial (-40°C to 85°C)

Revision History

Doc. Rev	Comments	Change Request Ref.
6257AS	First issue	



Headquarters

Atmel Corporation

2325 Orchard Parkway
San Jose, CA 95131
USA
Tel: 1(408) 441-0311
Fax: 1(408) 487-2600

International

Atmel Asia

Room 1219
Chinachem Golden Plaza
77 Mody Road Tsimshatsui
East Kowloon
Hong Kong
Tel: (852) 2721-9778
Fax: (852) 2722-1369

Atmel Europe

Le Krebs
8, Rue Jean-Pierre Timbaud
BP 309
78054 Saint-Quentin-en-
Yvelines Cedex
France
Tel: (33) 1-30-60-70-00
Fax: (33) 1-30-60-71-11

Atmel Japan

9F, Tonetsu Shinkawa Bldg.
1-24-8 Shinkawa
Chuo-ku, Tokyo 104-0033
Japan
Tel: (81) 3-3523-3551
Fax: (81) 3-3523-7581

Product Contact

Web Site

www.atmel.com
www.atmel.com/AT91SAM

Technical Support

AT91SAM Support

Sales Contacts

www.atmel.com/contacts/

Literature Requests

www.atmel.com/literature

Disclaimer: The information in this document is provided in connection with Atmel products. No license, express or implied, by estoppel or otherwise, to any intellectual property right is granted by this document or in connection with the sale of Atmel products. **EXCEPT AS SET FORTH IN ATMEL'S TERMS AND CONDITIONS OF SALE LOCATED ON ATMEL'S WEB SITE, ATMEL ASSUMES NO LIABILITY WHATSOEVER AND DISCLAIMS ANY EXPRESS, IMPLIED OR STATUTORY WARRANTY RELATING TO ITS PRODUCTS INCLUDING, BUT NOT LIMITED TO, THE IMPLIED WARRANTY OF MERCHANTABILITY, FITNESS FOR A PARTICULAR PURPOSE, OR NON-INFRINGEMENT. IN NO EVENT SHALL ATMEL BE LIABLE FOR ANY DIRECT, INDIRECT, CONSEQUENTIAL, PUNITIVE, SPECIAL OR INCIDENTAL DAMAGES (INCLUDING, WITHOUT LIMITATION, DAMAGES FOR LOSS OF PROFITS, BUSINESS INTERRUPTION, OR LOSS OF INFORMATION) ARISING OUT OF THE USE OR INABILITY TO USE THIS DOCUMENT, EVEN IF ATMEL HAS BEEN ADVISED OF THE POSSIBILITY OF SUCH DAMAGES.** Atmel makes no representations or warranties with respect to the accuracy or completeness of the contents of this document and reserves the right to make changes to specifications and product descriptions at any time without notice. Atmel does not make any commitment to update the information contained herein. Unless specifically provided otherwise, Atmel products are not suitable for, and shall not be used in, automotive applications. Atmel's products are not intended, authorized, or warranted for use as components in applications intended to support or sustain life.



© 2008 Atmel Corporation. All rights reserved. Atmel®, logo and combinations thereof, DataFlash®, SAM-BA® and others are registered trademarks or trademarks of Atmel Corporation or its subsidiaries. ARM® the ARM® Powered logo and others are registered trademarks or trademarks of ARM Ltd. Other terms and product names may be trademarks of others.