



6N90

Preliminary

Power MOSFET

6.2 Amps, 900 Volts N-CHANNEL POWER MOSFET

DESCRIPTION

The UTC **6N90** is an N-channel enhancement mode Power FET using UTC's advanced technology to provide costumers with planar stripe and DMOS technology. This technology allows a minimum on-state resistance and superior switching performance. It also can withstand high energy pulse in the avalanche and commutation mode.

The UTC **6N90** is generally applied in high efficiency switch mode power supplies.

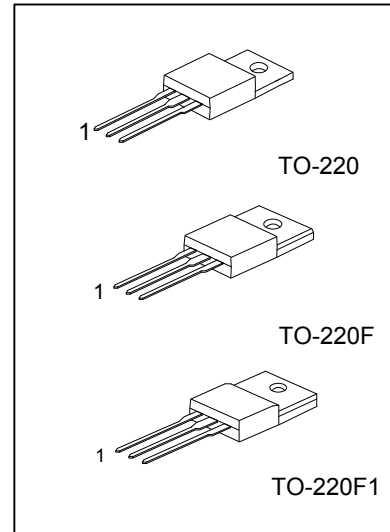

FEATURES

- * 6.2A, 900V, $R_{DS(on)} = 2.3\Omega @ V_{GS} = 10V$
- * Fast switching
- * 100% avalanche tested
- * Improved dv/dt capability
- * Halogen Free

SYMBOL

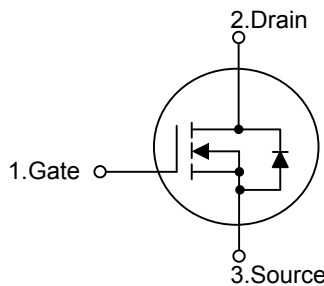

ORDERING INFORMATION

Ordering Number		Package	Pin Assignment			Packing
Lead Free	Halogen Free		1	2	3	
6N90L-TA3-T	6N90G-TA3-T	TO-220	G	D	S	Tube
6N90L-TF3-T	6N90G-TF3-T	TO-220F	G	D	S	Tube
6N90L-TF1-T	6N90G-TF1-T	TO-220F1	G	D	S	Tube

Note: Pin Assignment: G: Gate D: Drain S: Source

<p>6N90L - TA3 - T</p> <p>(1) Packing Type (2) Package Type (3) Lead Free</p>	<p>(1) T: Tube (2) TA3: TO-220, TF3: TO-220F, TF1: TO-220F1 (3) G: Halogen Free, L: Lead Free</p>
---	---

■ ABSOLUTE MAXIMUM RATINGS ($T_C=25^\circ\text{C}$, unless otherwise specified)

PARAMETER		SYMBOL	RATINGS	UNIT
Drain-Source Voltage		V_{DSS}	900	V
Gate-Source Voltage		V_{GSS}	± 30	V
Drain Current	Continuous ($T_C=25^\circ\text{C}$)	I_D	6.2	A
	Pulsed (Note 1)	I_{DM}	24	A
Avalanche Energy	Single Pulsed (Note 2)	E_{AS}	650	mJ
	Repetitive (Note 1)	E_{AR}	16.7	mJ
Peak Diode Recovery dv/dt (Note 3)		dv/dt	4.5	V/ns
Power Dissipation	TO-220	P_D	167	W
	TO-220F/TO220F1		56	W
Junction Temperature		T_J	+150	$^\circ\text{C}$
Storage Temperature		T_{STG}	-55~+150	$^\circ\text{C}$

Note: Absolute maximum ratings are those values beyond which the device could be permanently damaged.

Absolute maximum ratings are stress ratings only and functional device operation is not implied.

* Drain current limited by maximum junction temperature.

■ THERMAL CHARACTERISTICS

PARAMETER		SYMBOL	RATINGS	UNIT
Junction to Ambient	TO-220	θ_{JA}	62.5	$^\circ\text{C/W}$
	TO-220F/TO220F1		62.5	$^\circ\text{C/W}$
Junction to Case	TO-220	θ_{JC}	0.75	$^\circ\text{C/W}$
	TO-220F/TO220F1		2.25	$^\circ\text{C/W}$

■ ELECTRICAL CHARACTERISTICS ($T_C=25^\circ\text{C}$, unless otherwise specified)

PARAMETER	SYMBOL	TEST CONDITIONS	MIN	TYP	MAX	UNIT
OFF CHARACTERISTICS						
Drain-Source Breakdown Voltage	BV_{DSS}	$I_D=250\mu\text{A}$, $V_{GS}=0\text{V}$	900			V
Breakdown Voltage Temperature Coefficient	$\Delta BV_{DSS}/\Delta T_J$	Reference to 25°C , $I_D=250\mu\text{A}$		1.07		$V/^\circ\text{C}$
Drain-Source Leakage Current	I_{DSS}	$V_{DS}=900\text{V}$, $V_{GS}=0\text{V}$			10	μA
		$V_{DS}=720\text{V}$, $T_C=125^\circ\text{C}$			100	
Gate- Source Leakage Current	Forward	$V_{GS}=+30\text{V}$, $V_{DS}=0\text{V}$			+100	nA
	Reverse	$V_{GS}=-30\text{V}$, $V_{DS}=0\text{V}$			-100	nA
ON CHARACTERISTICS						
Gate Threshold Voltage	$V_{GS(TH)}$	$V_{DS}=V_{GS}$, $I_D=250\mu\text{A}$	3.0		5.0	V
Static Drain-Source On-State Resistance	$R_{DS(ON)}$	$V_{GS}=10\text{V}$, $I_D=3.1\text{A}$		1.93	2.3	Ω
Forward Transconductance	g_{FS}	$V_{DS}=50\text{V}$, $I_D=3.1\text{A}$ (Note 4)		5.5		S
DYNAMIC PARAMETERS						
Input Capacitance	C_{ISS}	$V_{GS}=0\text{V}$, $V_{DS}=25\text{V}$, $f=1.0\text{MHz}$		1360	1770	pF
Output Capacitance	C_{OSS}			110	145	pF
Reverse Transfer Capacitance	C_{RSS}			11	15	pF
SWITCHING PARAMETERS						
Total Gate Charge	Q_G	$V_{GS}=10\text{V}$, $V_{DS}=720\text{V}$, $I_D=6.2\text{A}$ (Note 4, 5)		30	40	nC
Gate to Source Charge	Q_{GS}			9.0		nC
Gate to Drain Charge	Q_{GD}			12		nC
Turn-ON Delay Time	$t_{D(ON)}$	$V_{DD}=450\text{V}$, $I_D=6.2\text{A}$, $R_G=25\Omega$ (Note 4, 5)		35	80	ns
Rise Time	t_R			90	190	ns
Turn-OFF Delay Time	$t_{D(OFF)}$			55	120	ns
Fall-Time	t_F			60	130	ns
SOURCE- DRAIN DIODE RATINGS AND CHARACTERISTICS						
Maximum Body-Diode Continuous Current	I_S				6.0	A
Maximum Body-Diode Pulsed Current	I_{SM}				24	A
Drain-Source Diode Forward Voltage	V_{SD}	$I_S=6.2\text{A}$, $V_{GS}=0\text{V}$			1.4	V
Body Diode Reverse Recovery Time	t_{RR}	$I_S=6.2\text{A}$, $V_{GS}=0\text{V}$, $di_F/dt=100\text{A}/\mu\text{s}$		630		ns
Body Diode Reverse Recovery Charge	Q_{RR}	(Note 4)		6.9		μC

Note: 1. Repetitive Rating: Pulse width limited by maximum junction temperature

2. $L = 34\text{mH}$, $I_{AS} = 6\text{A}$, $V_{DD} = 50\text{V}$, $R_G = 25\Omega$, Starting $T_J = 25^\circ\text{C}$

3. $I_{SD} \leq 6\text{A}$, $di/dt \leq 200\text{A}/\mu\text{s}$, $V_{DD} \leq BV_{DSS}$, Starting $T_J = 25^\circ\text{C}$

4. Pulse Test: Pulse width $\leq 300\mu\text{s}$, Duty cycle $\leq 2\%$

5. Essentially independent of operating temperature

■ TEST CIRCUITS AND WAVEFORMS

Gate Charge Test Circuit

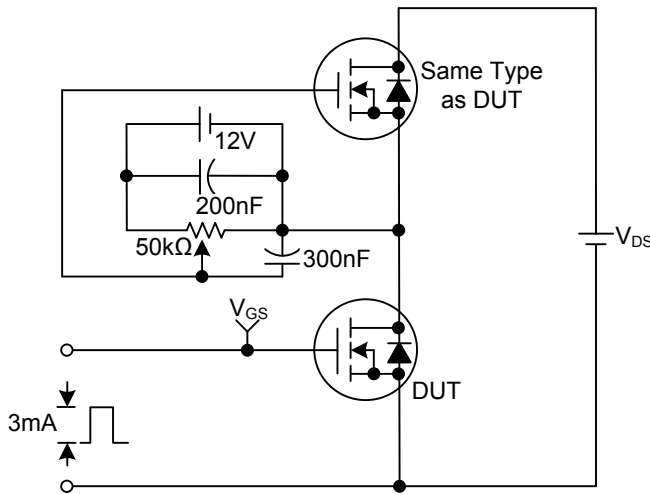

Gate Charge Waveforms

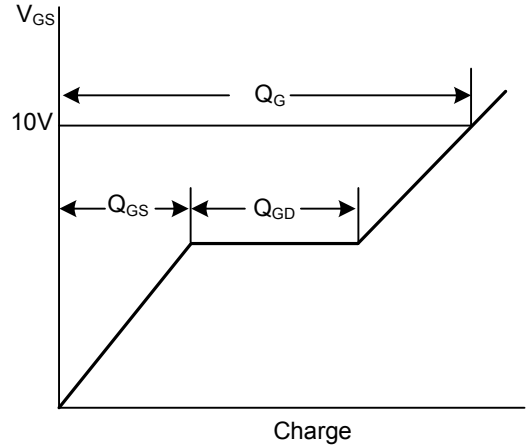

Resistive Switching Test Circuit

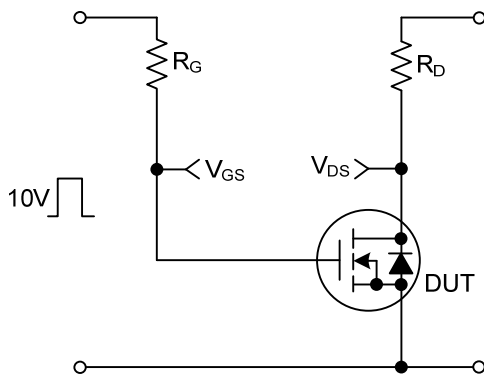

Resistive Switching Waveforms

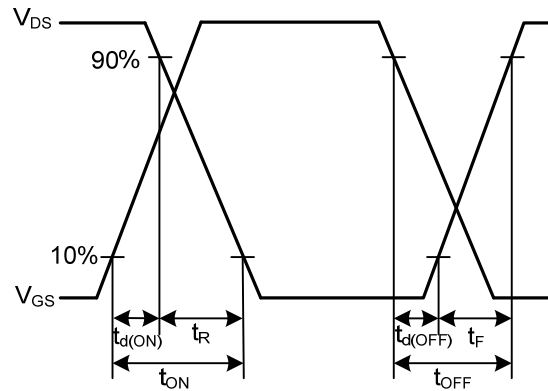

Unclamped Inductive Switching Test Circuit

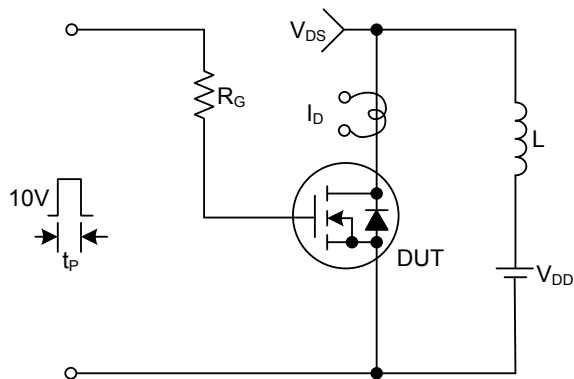

Unclamped Inductive Switching Waveforms

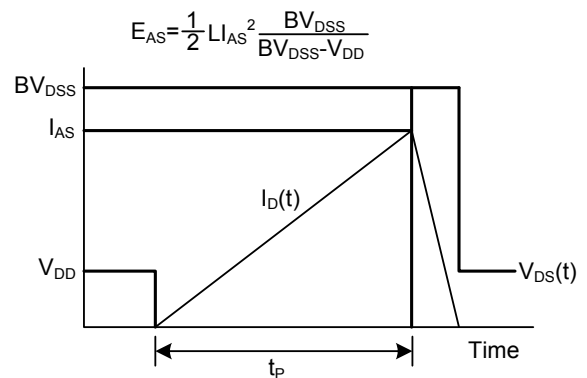

Peak Diode Recovery dv/dt Test Circuit & Waveforms

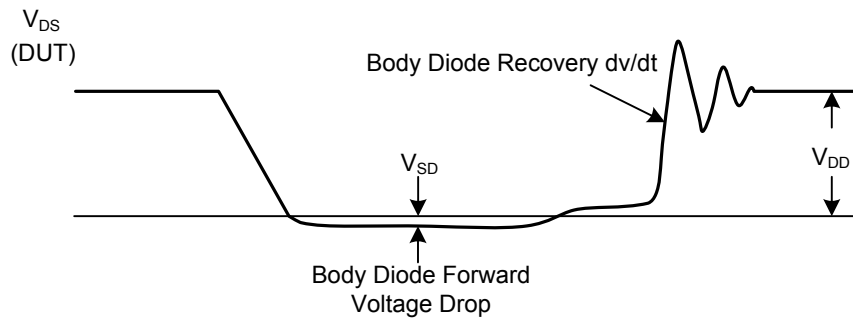
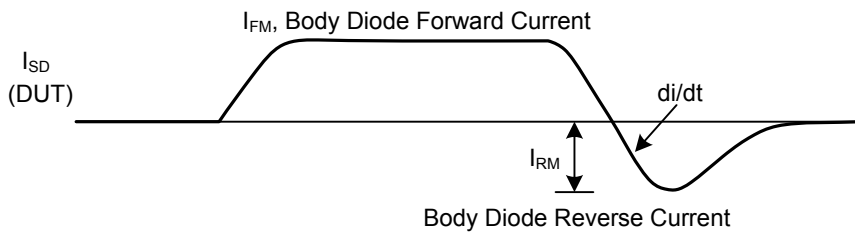
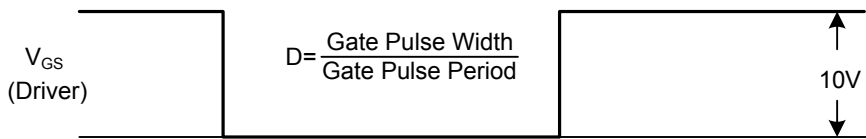
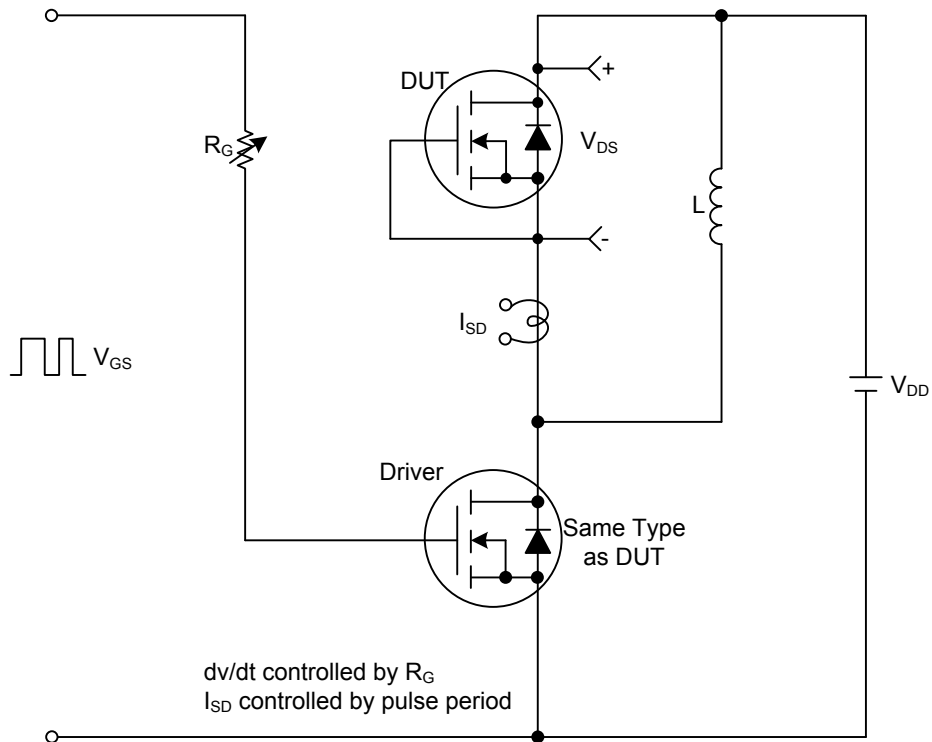

UTC assumes no responsibility for equipment failures that result from using products at values that exceed, even momentarily, rated values (such as maximum ratings, operating condition ranges, or other parameters) listed in products specifications of any and all UTC products described or contained herein. UTC products are not designed for use in life support appliances, devices or systems where malfunction of these products can be reasonably expected to result in personal injury. Reproduction in whole or in part is prohibited without the prior written consent of the copyright owner. The information presented in this document does not form part of any quotation or contract, is believed to be accurate and reliable and may be changed without notice.