

Preliminary

## TMP68301 68HC000 Based Integrated Microprocessor

### DISTINCTIVE CHARACTERISTICS

- 68HC000 Core based microprocessor.
- 3 Asynchronous serial ports with baud rate generators with optional modem control.
- 16 bit parallel interface with optional Centronics interface port.
- 3 Timer channels, 16 bits each with an 8 bit prescaler.
- Built-in interrupt controller, 3 external and 7 internal channels with auto interrupt vector generation.
- Sophisticated address decoder, includes relocatable chip select generation for internal registers and external chip selects.
- Automatic DTACK generation with 0 to 7 wait states and programmable BERR generation.

### BLOCK DIAGRAM

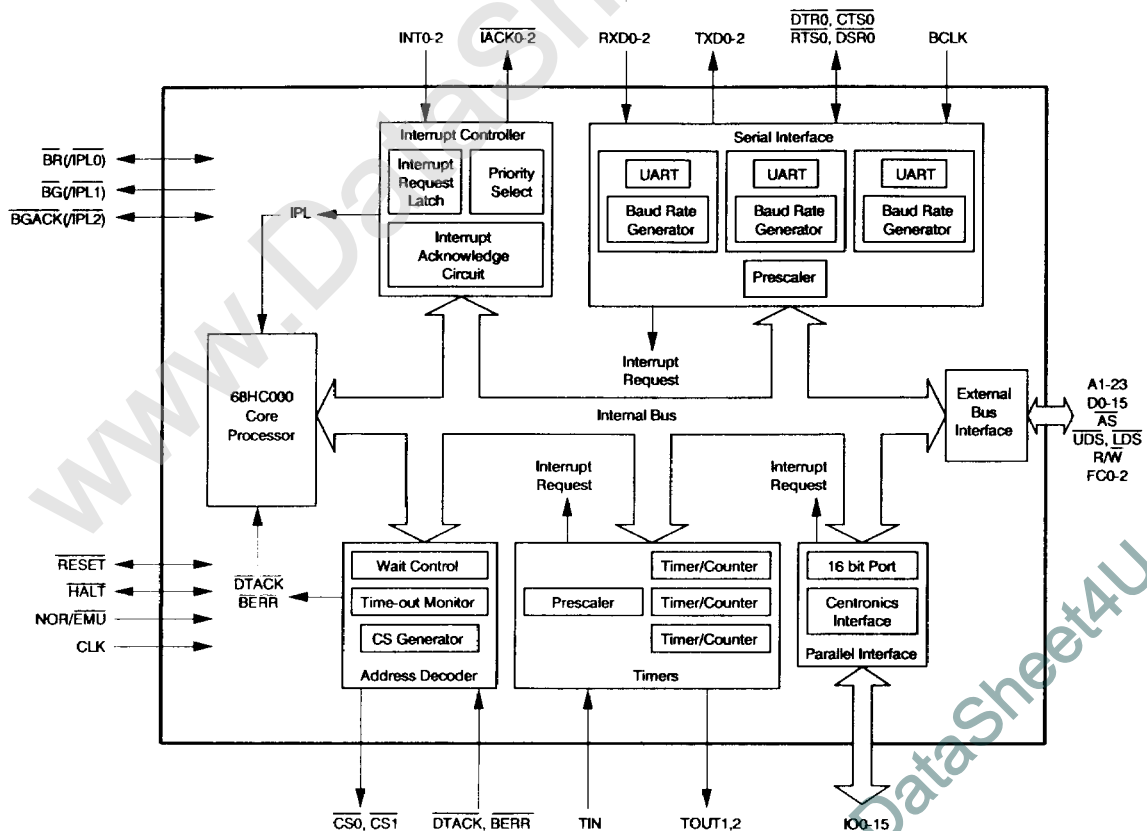

---

## GENERAL DESCRIPTION

Toshiba's TMP68301 is a single-chip, integrated controller utilizing the CMOS 68HC000 microprocessor as the core processor. Standard peripherals circuits required by the 68HC000 are built into the TMP68301. Built-in circuits include 3 serial interfaces, a parallel interface, 3 timers, an interrupt controller and an address decoder.

The TMP68301 has two operating modes. The first is the normal operation mode in which the full functionality of the chip is available. The

second mode is the emulation mode. In the emulation mode, the 68HC000 core does not operate and the built-in peripheral devices are operated by external bus signals.

The TMP68301 can be used where low-power operation or high-performance or low-cost are required. The TMP68301 is usable for a wide variety of applications, such as dot matrix and laser printers, hand-held data terminals and embedded controllers.

---

## TYPICAL TMP68301 APPLICATION

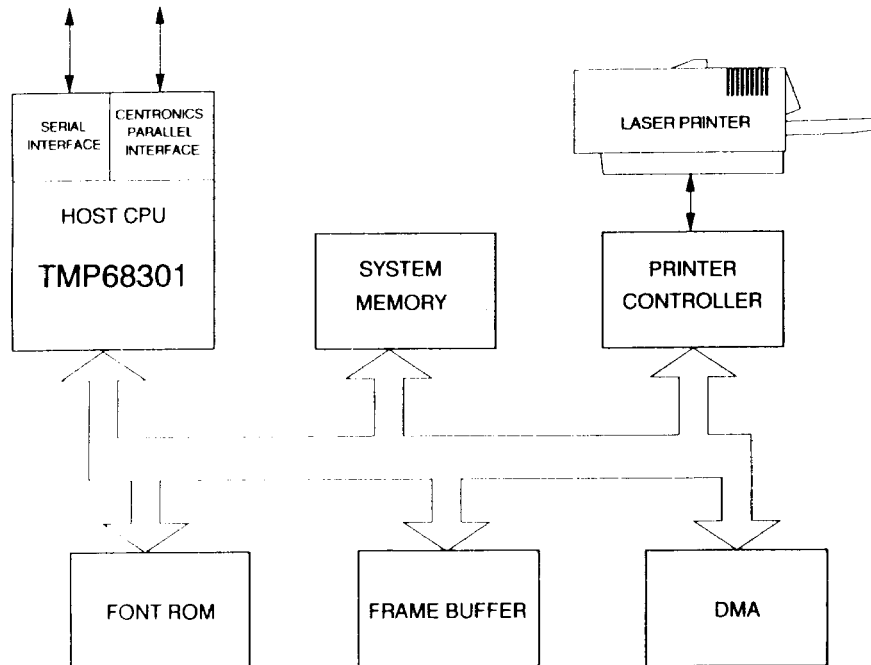

**TMP68301 Laser Printer System**

---

For further information, please contact:

Amar Dhillon or Scott Thomas  
**TOSHIBA AMERICA ELECTRONIC COMPONENTS, INC.**  
9775 Toledo Way, Irvine, CA 92718  
(714) 455-2000  
or, your local salesperson at:  
**REGIONAL SALES OFFICES**

**NORTHWEST REGION**  
Sunnyvale, CA (408) 737-9844

**CENTRAL REGION**  
Deerfield, IL (708) 945-1500

**EASTERN REGION**  
Burlington, MA (617) 272-4352

**SOUTHWEST REGION**  
Tustin, CA (714) 259-0368

**SOUTHCENTRAL REGION**  
Richardson, TX (214) 480-0470

**SOUTHEAST REGION**  
Norcross, GA (404) 368-0203