

August 22, 2000

TEL:805-498-2111 FAX:805-498-3804 WEB:http://www.semtech.com

DESCRIPTION

The SC1408 is a low voltage boost controller that operates from a 1.8V to 16.5V input range. A shutdown pin allows the user to turn the controller off reducing supply current to less than 2 μ A typical. Output voltage can be preset to 5V or is adjustable from 3V to 16.5V with a resistor divider. The controller changes frequency in low load conditions to improve efficiency.

The SC1408 was designed for two cell Alkaline or single cell Lithium Ion battery applications. With the proper external components it can be used as a boost converter or a buck/boost converter.

A current sense is implemented with an external resistor that is not in the load current path.

The SC1408 operates in "bootstrapped" mode. When the input voltage to the device is less than 2.5V during startup, a low voltage 50% fixed duty cycle oscillator is switched in to initiate boost action.

FEATURES

- 1.8V to 16.5V input range
- Up to 10W output power
- Preset 5V or adjustable output
- Up to 300kHz switching frequency
- 10 μ A max shutdown current
- Industrial temperature range
- SO-8 or MSOP-8 package

APPLICATIONS

- PDA Power supplies
- Battery powered applications
- Positive LCD Bias generator
- Portable communications (cellular phones)
- Peripheral card supplies
- Industrial power supplies

ORDERING INFORMATION

Part Number ⁽¹⁾	Package	Temp. Range (T _A)
SC1408IS.TR	SO-8	-40° to +85°C
SC1408IMS.TR	MSOP-8	

Note:

(1) Only available in tape and reel packaging. A reel contains 2500 devices.

TYPICAL APPLICATION - BOOST CONFIGURATION

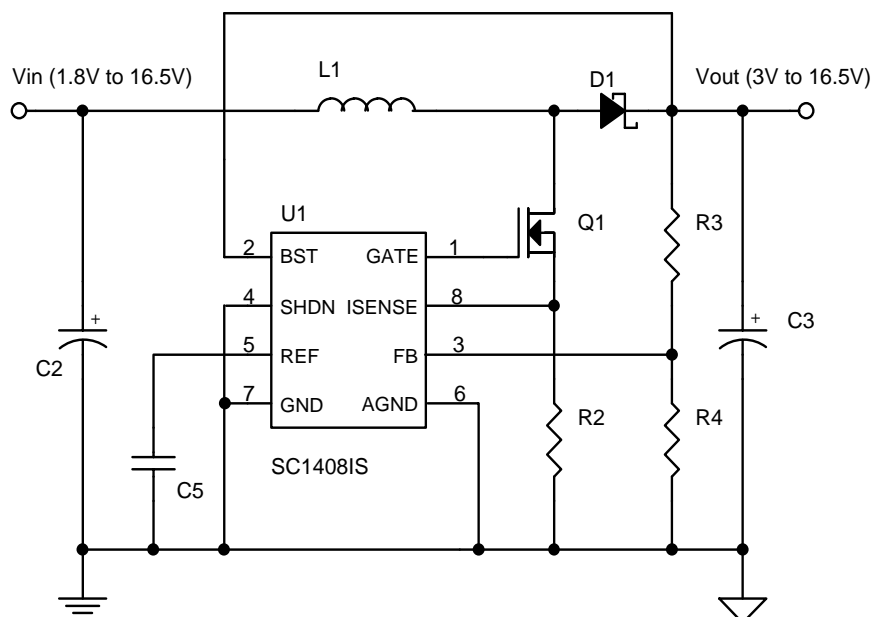

August 22, 2000

ABSOLUTE MAXIMUM RATINGS

Parameter	Symbol	Maximum	Units
Input Voltage	BST to GND	-0.3 to 18	V
Small Signal Ground to Power Ground	GND to AGND	±0.1	V
GATE to GND		-0.3 to VBST+0.3	V
FB, SHDN, REF, ISENSE to GND		-0.3 to min. of VBST+0.3 or 5	V
Operating Temperature	T _A	-40 to +85	°C
Junction Temperature Range	T _J	-40 to +150	°C
Storage Temperature	T _{STG}	-65 to +160	°C
Lead Temperature (Soldering) 10 seconds	T _L	+300	°C
Thermal Resistance, Junction to Ambient SO-8	θ _{JA}	165	°C/W
MSOP-8		206	
Thermal Resistance, Junction to Case SO-8/MSOP-8	θ _{JC}	40	°C/W

ELECTRICAL CHARACTERISTICS⁽¹⁾

 Unless specified: V_{OUT} = 5V; I_{LOAD} = 0mA; T_A = +25°C

PARAMETER	SYM	CONDITIONS		MIN	TYP	MAX	UNITS
Input Voltage		T _A = 25°C		1.8		16.5	V
		T _A = -40°C to +85°C		1.8		16.5	V
Supply Current		V _{OUT} = 16.5V, SHDN ≤ 0.4V	T _A = -40°C to +85°C		110	140	uA
		V _{OUT} = 10V, 1.6V ≤ SHDN ≤ 5V	T _A = -40°C to +85°C		2	10	µA
Output Voltage		V _{IN} = 2.0V to 5.0V,	T _A = -40°C to +85°C	4.800	5.0	5.200	V
Load Regulation		V _{IN} = 2.0V, V _{OUT} = 5V, I _{LOAD} = 0mA to 500mA			60		mV/A
Line Regulation		V _{IN} = 2.7V to 4.0V, V _{OUT} = 5V, I _{LOAD} = 500mA			7		mV/V
Minimum Start Up Voltage		No load				1.8	V
Maximum Switch On Time	T _{ON}			9.6	16	22.4	µs
Minimum Switch Off Time	T _{OFF}			1.4	2.3	3.2	µs
Efficiency		V _{IN} = 4V, V _{OUT} = 5V, I _{LOAD} = 500mA			87		%
Reference Voltage	V _{REF}	I _{REF} = 0µA	T _A = -40°C to +85°C	1.176	1.200	1.224	V
Reference Load Regulation		0µA ≤ I _{REF} ≤ 100µA			-4	10	mV
Reference Line Regulation		5V ≤ V _{OUT} ≤ 16.5V			40	100	µV/V
FB Trip Point Voltage	V _{FB}	T _A = 25°C T _A = -40°C to +85°C		1.176	1.200	1.224	V
FB Input Current	I _{FM}	T _A = 25°C T _A = -40°C to +85°C			-4	±40	nA

August 22, 2000

ELECTRICAL CHARACTERISTICS⁽¹⁾

 Unless specified: $V_{OUT} = 5V$; $I_{LOAD} = 0mA$; $T_A = +25^{\circ}C$

PARAMETER	SYM	CONDITIONS	MIN	TYP	MAX	UNITS
SHDN Input High Voltage	V_{IH}	$V_{OUT} = 2.7V$ to $16.5V$	1.6			V
SHDN Input Low Voltage	V_{IL}	$V_{OUT} = 2.7V$ to $16.5V$			0.4	V
SHDN Input Current	I_{IN}	$V_{OUT} = 16.5V$, SHDN = 0V or 5V			± 1	μA
Current Limit Trip Level	V_{CS}	$V_{OUT} = 3V$ to $16.5V$ $T_A = 25^{\circ}C$ $T_A = -40^{\circ}C$ to $+85^{\circ}C$	85 80	100	115 120	mV
ISENSE Input Current	I_{SENSE}			0.01	± 1	μA
GATE Rise Time		$V_{OUT} = 5V$, 1nF from GATE to GND		50		ns
GATE Fall Time		$V_{OUT} = 5V$, 1nF from GATE to GND		50		
GATE On Resistance		GATE = high or low		15	30	Ω

NOTE:

(1) This device is ESD sensitive. Use of standard ESD handling precautions is required.

August 22, 2000

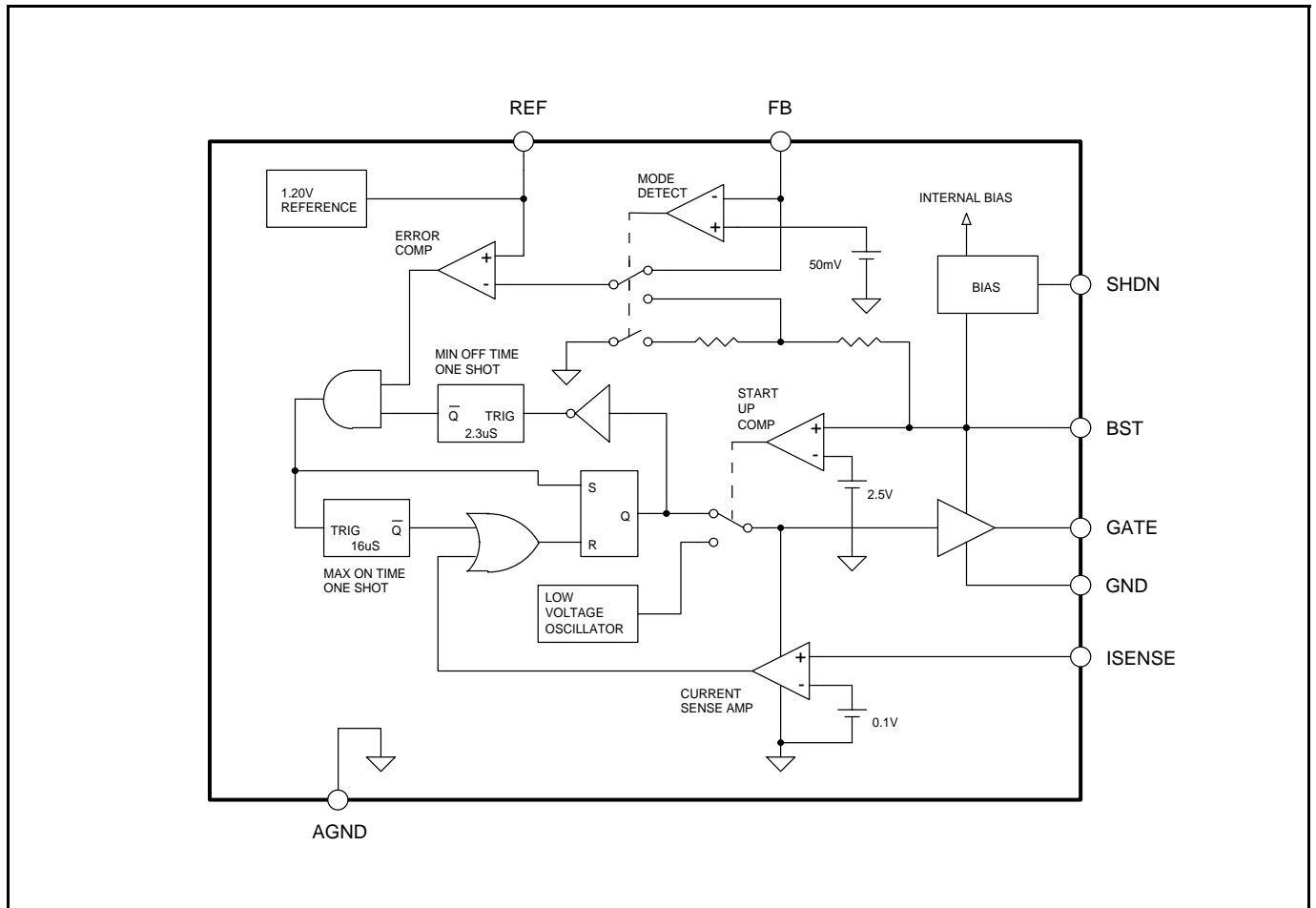
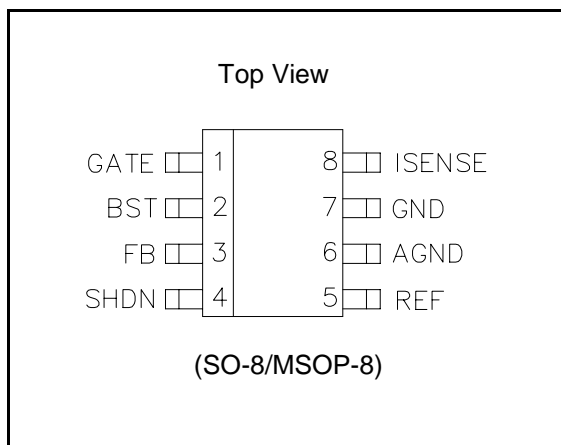
BLOCK DIAGRAM

PIN CONFIGURATION

PIN DESCRIPTION

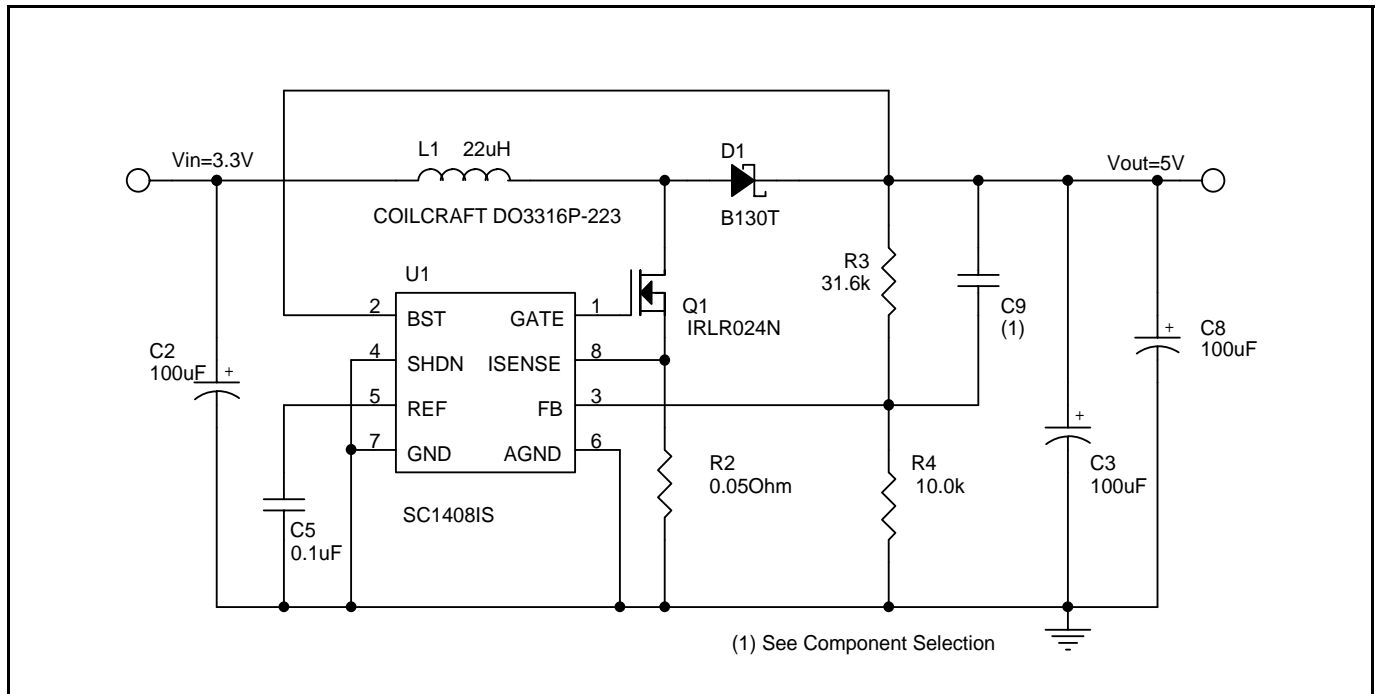
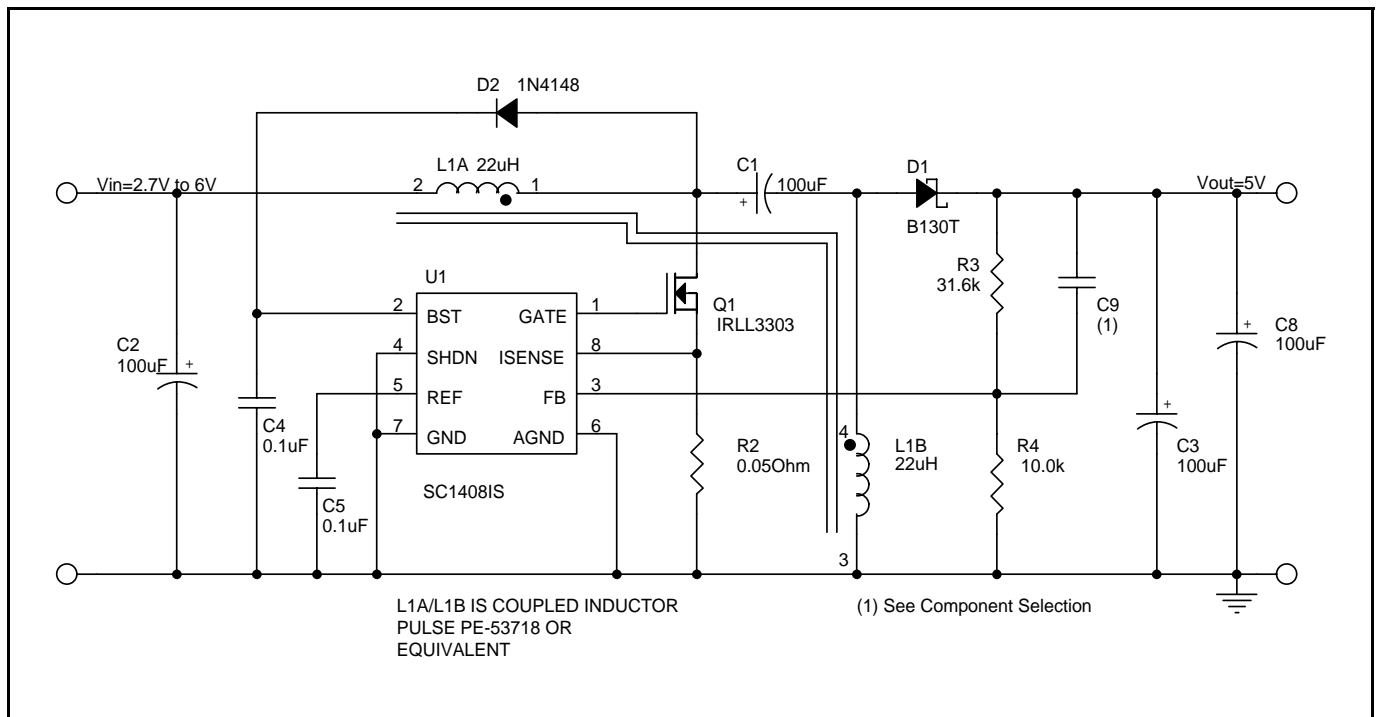
Pin #	Pin Name	Pin Function
1	GATE	Gate drive output.
2	BST	Supply voltage.
3	FB	Voltage feedback.
4	SHDN	Logic high shuts down the converter.
5	REF	Reference output pin.
6	AGND	Small signal analog and digital ground.
7	GND	Power ground.
8	ISENSE	Current sense pin.

August 22, 2000

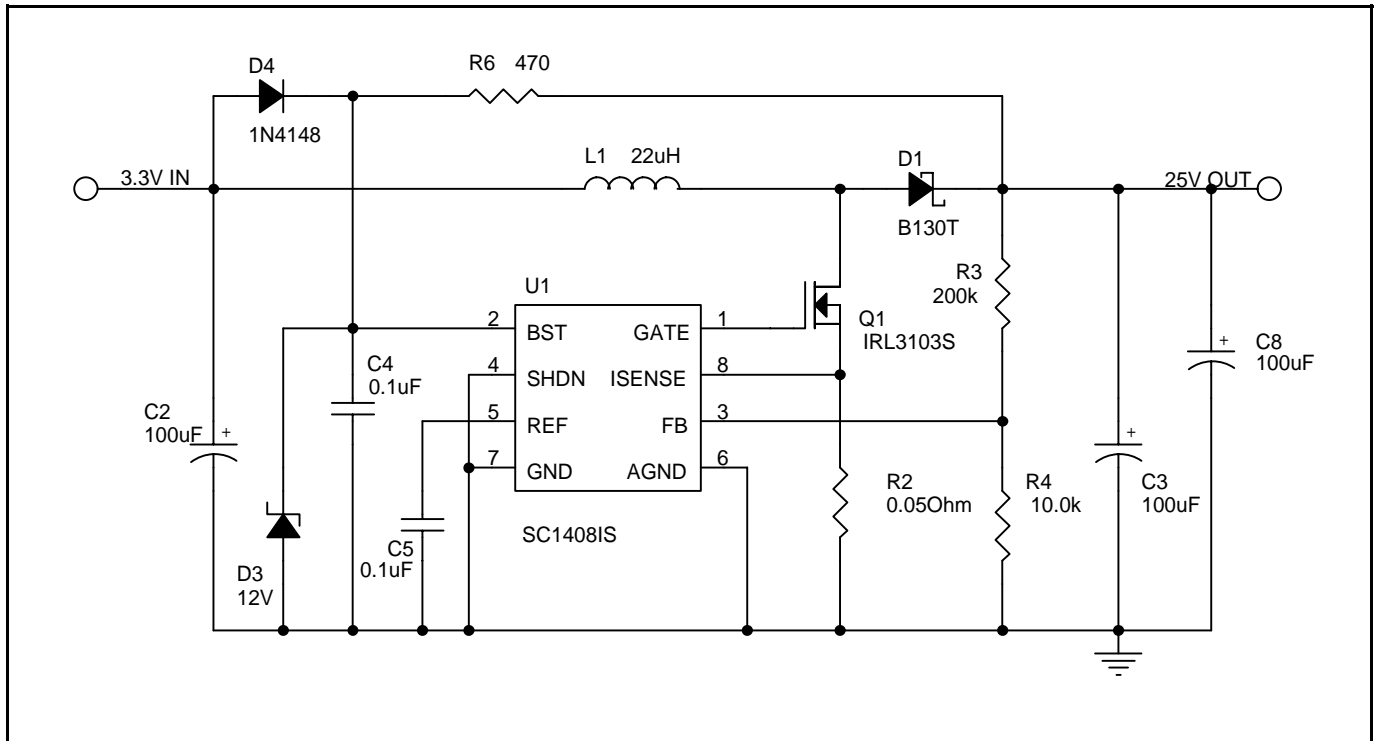
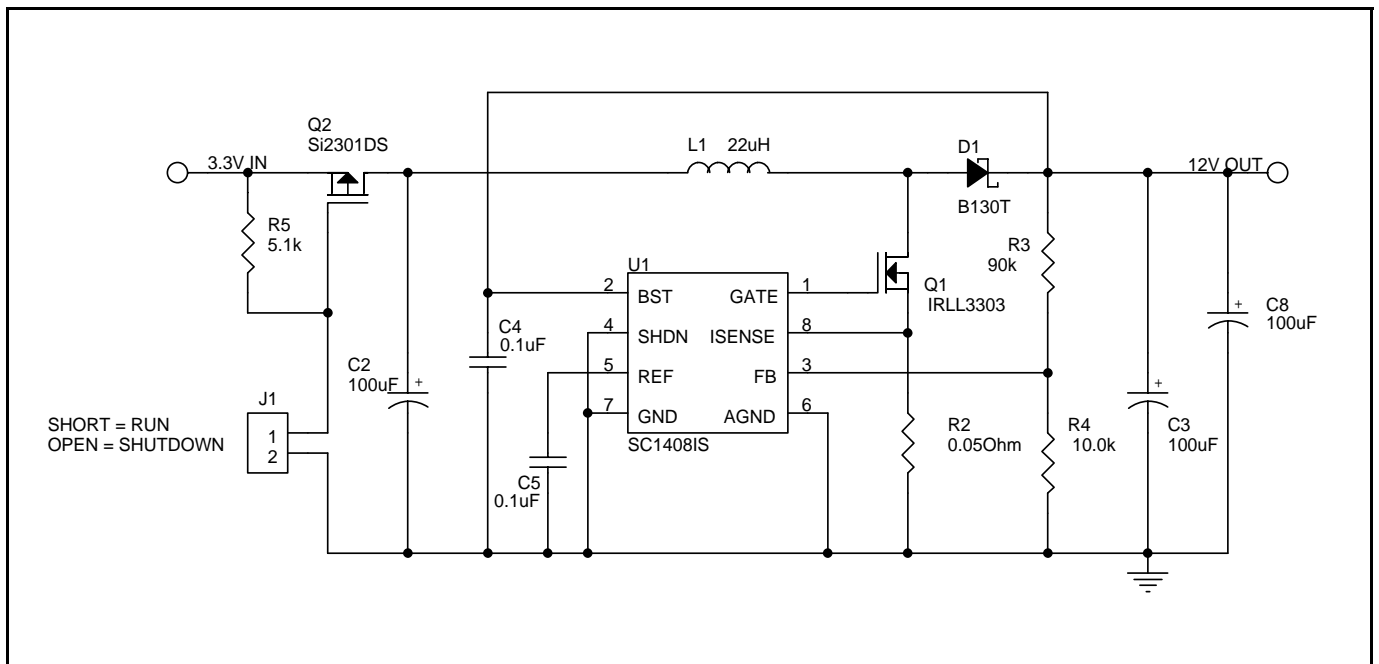
Fig. 1: Typical Application - Boost Configuration

Fig. 2: Typical Application - Buck/Boost (SEPIC) Configuration

August 22, 2000

Fig. 3: Achieving output voltages greater than 16.5V

Fig. 4: Implementing shutdown with input/output isolation

August 22, 2000

THEORY OF OPERATION

The SC1408 is a modified hysteretic boost converter controller. The power switch is turned on when the output voltage falls slightly below its setpoint. It remains on for approximately 16μs, or until the inductor current reaches limit, whichever occurs first. The power switch is then turned off for 2.3μs, or until the output voltage once again falls below setpoint, whichever occurs last.

The SC1408 is normally powered from the output voltage. Internal circuitry, such as the bandgap, comparators and one shots will not function properly until the BST pin voltage reaches 2.5V. To ensure startup at low input voltages, the normal control circuitry is disabled and a special, low voltage start up oscillator generates an approximate square wave at the GATE pin, initiating boost action. When the output voltage reaches 2.5V, the normal control circuitry is enabled and the start up oscillator shuts down.

To conserve power, a SHDN pin is provided which, when pulled high, shuts down most internal circuitry. The output voltage will then be one diode drop below the input.

COMPONENT SELECTION

Boost Converter

R_{SENSE}

The value of the sense resistor is the primary determining factor for maximum output current. The SC1408 has a fixed current limit voltage threshold, which is developed by the peak inductor current flowing through R_{SENSE}. R_{SENSE} may be determined either from the maximum output current curves or from the equation below:

$$I_{O(MAX)} = \frac{V_{CS}}{R_{SENSE}} \left(1 - \frac{V_O + V_F - V_{IN}}{V_O + V_F - V_{FET}} \right) - \frac{t_{off}}{2L} \left(\frac{(V_{IN} - V_{FET})(V_O + V_F - V_{IN})}{V_O + V_F - V_{FET}} \right)$$

Where :

V_F = Output Diode Forward Voltage Drop

V_{FET} = Voltage across FET, R_{SENSE} and Inductor DCR

In the equation above, the use of 2.3μs for t_{off} may lead to slightly optimistic current values for low V_O/V_{IN} ratios. The theoretical curves use the actual value of t_{off}, V_F=0.5V, V_{FET}=0.3V and V_{CS}=0.08V and are generated for L=22μH.

Output Voltage

Output voltage can be set to 5V by connecting the FB

pin to GND, or to any voltage in the 3.0V to 16.5V range using external divider resistors.

The bottom resistor in the divider chain (R4) should be 300kΩ or less and the top resistor (R3 in the application circuits) can be calculated from:

$$R3 = R4 \left(\frac{V_O}{V_{REF}} - 1 \right)$$

Inductor

The SC1408 will work with a wide range of inductor values. A good choice for most applications is 22μH. Smaller inductor values result in higher peak currents and increased output ripple, while larger values will result in slower loop response.

Transistor Selection

Normally the power switch will be an N-channel MOSFET, although in certain circumstances an NPN bipolar may be substituted.

The choice of FET can be critical, especially in battery powered applications where the converter must be able to use all of the available energy in the battery. This requires that the converter be capable of starting up from very low input voltages. For example a two cell alkaline system's terminal voltage will drop to 1.8V as it approaches full discharge. For these demanding applications, a FET with low V_{GS(th)} is required. A good rule of thumb is that V_{GS(th)} should be at least 0.5V less than the minimum input voltage.

Diode

For most applications, a Schottky diode should be used as the output rectifier. It will be subjected to reverse voltages of at least V_O, and average current will be equal to the output current. Industry standard 1N5817 series or an equivalent surface mount part would be suitable.

Output Capacitors

Output capacitors should be low ESR to minimize ripple voltage and maximize efficiency. Low ESR tantalums, OSCONs or the newer Polymer capacitors should be used. Ripple voltage will be approximately:

$$V_{RIPPLE} = \frac{V_{CS} * R_{ESR}}{R_{SENSE}}$$

Input Capacitors

Input capacitors on a boost converter are less critical than the output capacitors, since there are no fast current pulses drawn from the input supply. A 100μF tantalum will be adequate for most applications.

August 22, 2000

Feed Forward Capacitor

Although converters based on the SC1408 are stable, with no possibility of oscillation, they are susceptible to "mode switching" at intermediate current levels. This leads to increased ripple voltage and slightly reduced efficiency. Mode switching can be eliminated by a suitable choice of C9. It is possible to empirically select C9. Start with a value of about 100pF and adjust until all low frequency output ripple is eliminated at the desired output current.

See AN99-15 "SC1408 Operating Modes" for a full discussion of the origins of "Mode switching" and a more analytical approach to the selection of C9.

COMPONENT SELECTION**SEPIC Converter****R_{SENSE}**

Again, with the SEPIC topology, the value of the sense resistor is the primary determining factor for maximum output current. The simplest approach to select R_{SENSE} is to add V_{IN} to V_O and use this value as the output voltage in the output current curves or in the equation for Boost converter.

Output Voltage

Output voltage setting works exactly the same in SEPIC topology as in Boost, including the ability to set to 5V by connecting the FB pin to GND. Care must be taken to ensure that the IC supply (pin2; BST) does not exceed its 16.5V rating. In the circuit of Fig.2: This requires maximum output voltage to be limited to 16.5V-V_{IN}. Higher output voltages are possible with different IC supply strategies.

Inductor

The SEPIC topology requires a coupled inductor. Again a good choice for most applications is 22uH. Smaller inductor values result in higher peak currents and increase output ripple, while larger values will result in slower loop response.

Transistor Selection

The choice of FET can be critical, especially in battery powered applications where the converter must be able to use all of the available energy in the battery. This requires that the converter be capable of starting up from very low input voltages. For example a two cell alkaline system's terminal voltage will drop to 1.8V as it approaches full discharge. For these demanding applications, a FET with low V_{GS(th)} is required. A good rule of thumb is that V_{GS(th)} should be at least 0.5V less than the minimum input voltage.

Diode

For most applications, a Schottky diode should be used as the output rectifier. It will be subjected to reverse voltages of at least V_O+V_{IN} and average current equal to the output current. Industry standard 1N5817 series or an equivalent surface mount part would be suitable.

Output Capacitors

Output capacitors should be low ESR to minimize ripple voltage and maximize efficiency. Low ESR tantalums, OSCONs or the newer Polymer capacitors should be used.

Input Capacitors

Input capacitors on a SEPIC converter are less critical than the output capacitors, since there are no fast current pulses drawn from the input supply. A 100uF tantalum will be adequate for most applications.

Series Capacitors

The Series capacitor(s) must be capable of handling an RMS current given by:-

$$I_{RMS} = I_O \sqrt{\frac{V_O + 0.5}{V_{IN}}}$$

Feed Forward Capacitor

The feed forward capacitor should be selected in the same way as for a Boost application.

LAYOUT GUIDELINES

The SC1408 is fairly insensitive to layout, however following some simple guidelines will help ensure successful implementation.

Whenever possible, lay the circuitry out over a ground plane. Connect AGND and GND together at the IC and return to the ground plane with one or two vias. Place the current sense resistor (R2), the REF decoupling capacitor (C5) and the divider resistors (R3 and R4) close to the IC, Return the ground side of these components to the ground plane close to the AGND/GND pin vias. Connect the top side of the sense resistor to ISENSE with a short trace and the source of Q1 directly to the sense resistor. Make the output loop Q1, D1 and the output capacitors (C3, C8) as small as possible to minimize EMI.

August 22, 2000

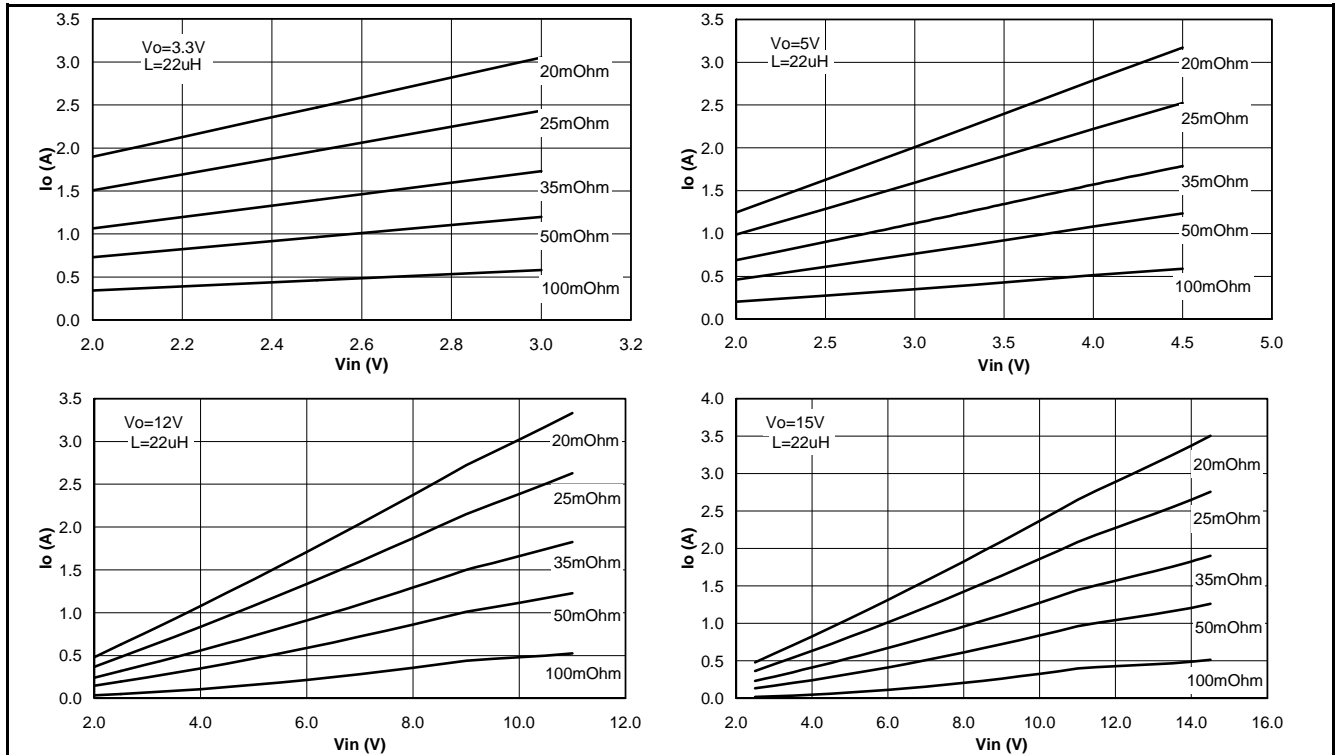

Figs. 5 - 8: Maximum output current vs. input voltage and sense resistor value. (Boost Mode)

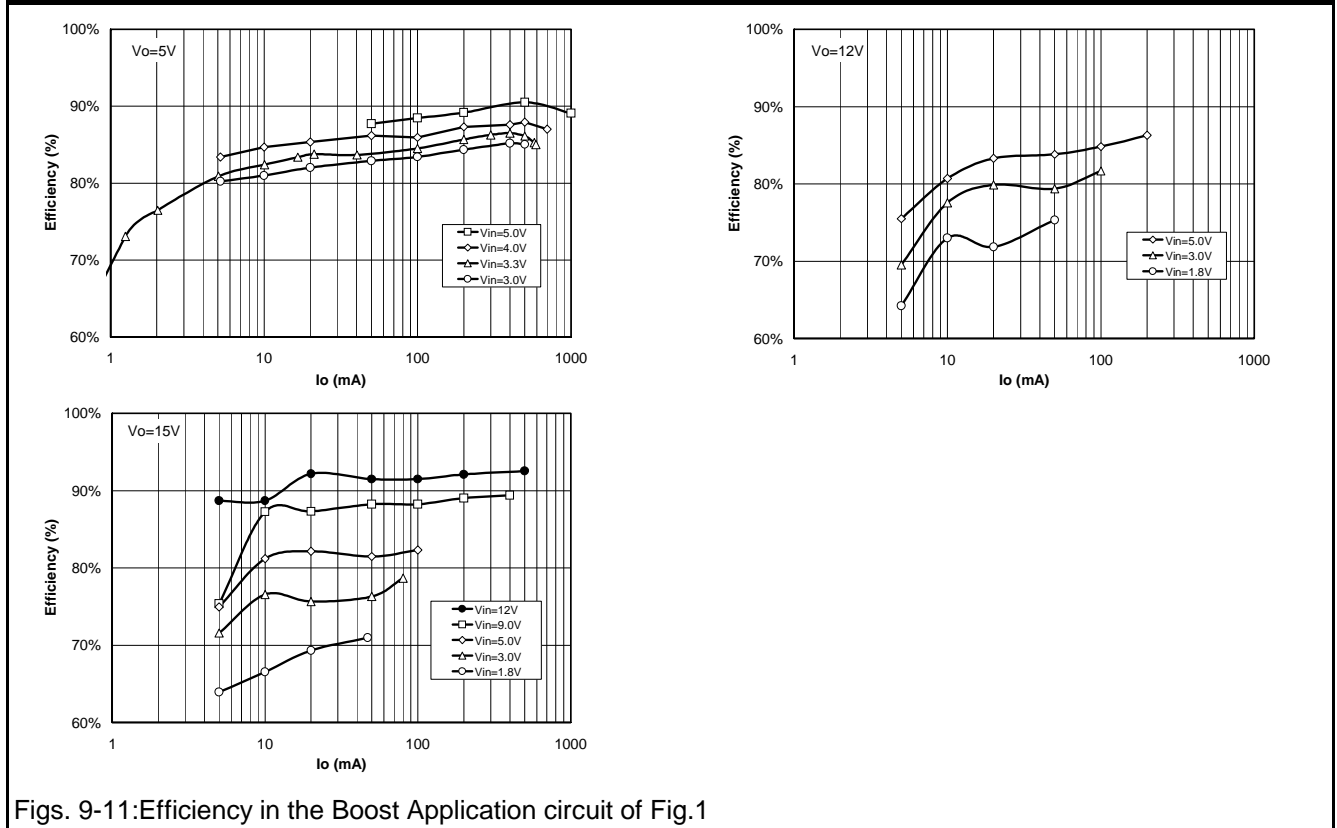

Figs. 9-11: Efficiency in the Boost Application circuit of Fig.1

August 22, 2000

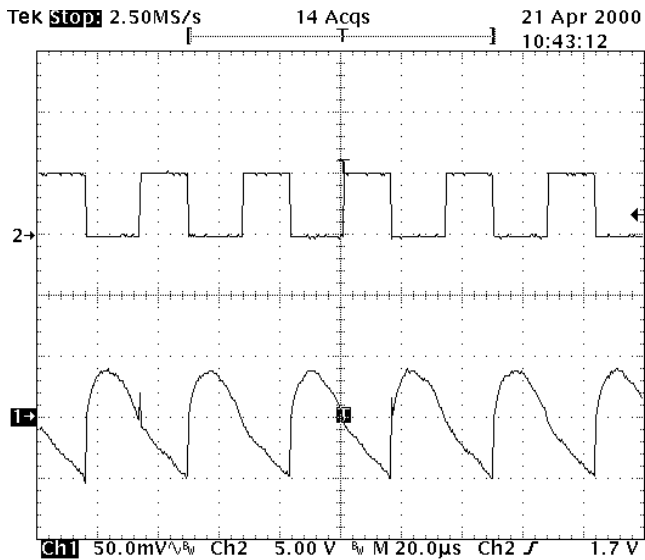

Output Ripple Voltage; $V_{in}=3V$, $V_o=5V$, $I_o=470mA$
 Ch1 = Output Ripple
 Ch2 = Voltage at GATE pin

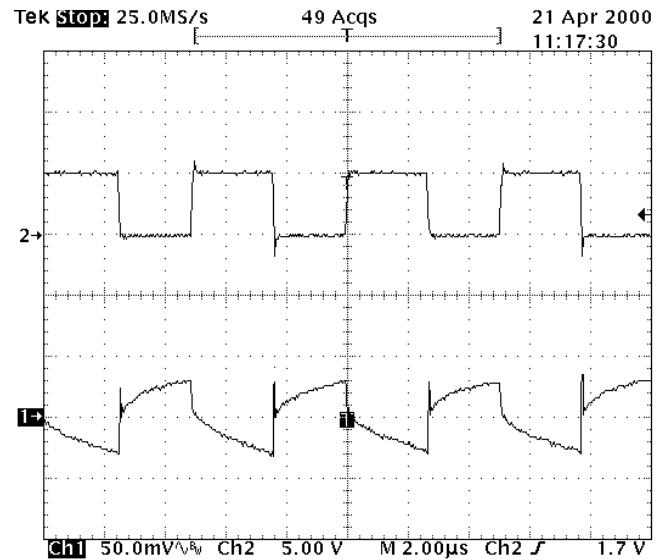

Output Ripple Voltage; $V_{in}=3V$, $V_o=5V$, $I_o=810mA$
 Ch1 = Output Ripple
 Ch2 = Voltage at GATE pin

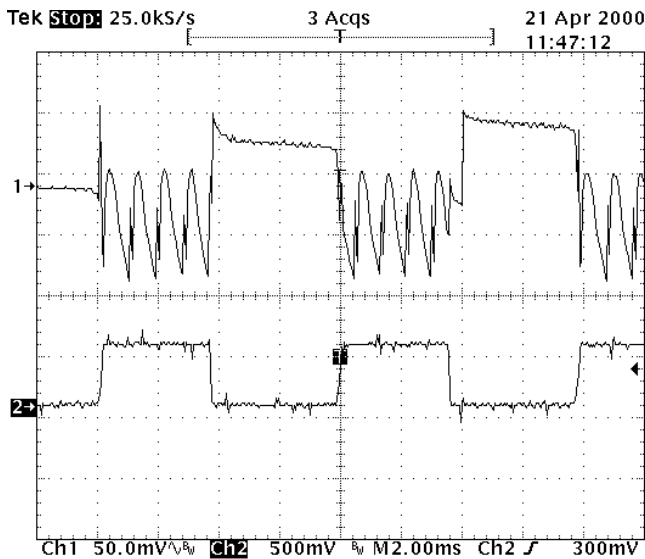

Load Transient; $V_{in}=3V$, $V_o=5V$, $I_o=0$ to $500mA$
 Ch1 = Output Voltage
 Ch2 = Load Current (0.5A/div)

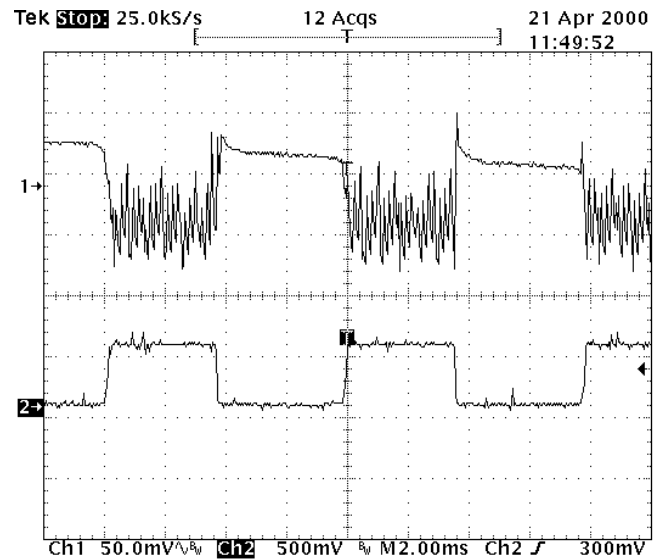

Load Transient; $V_{in}=2V$, $V_o=5V$, $I_o=0$ to $500mA$
 Ch1 = Output Voltage
 Ch2 = Load Current (0.5A/div)

August 22, 2000

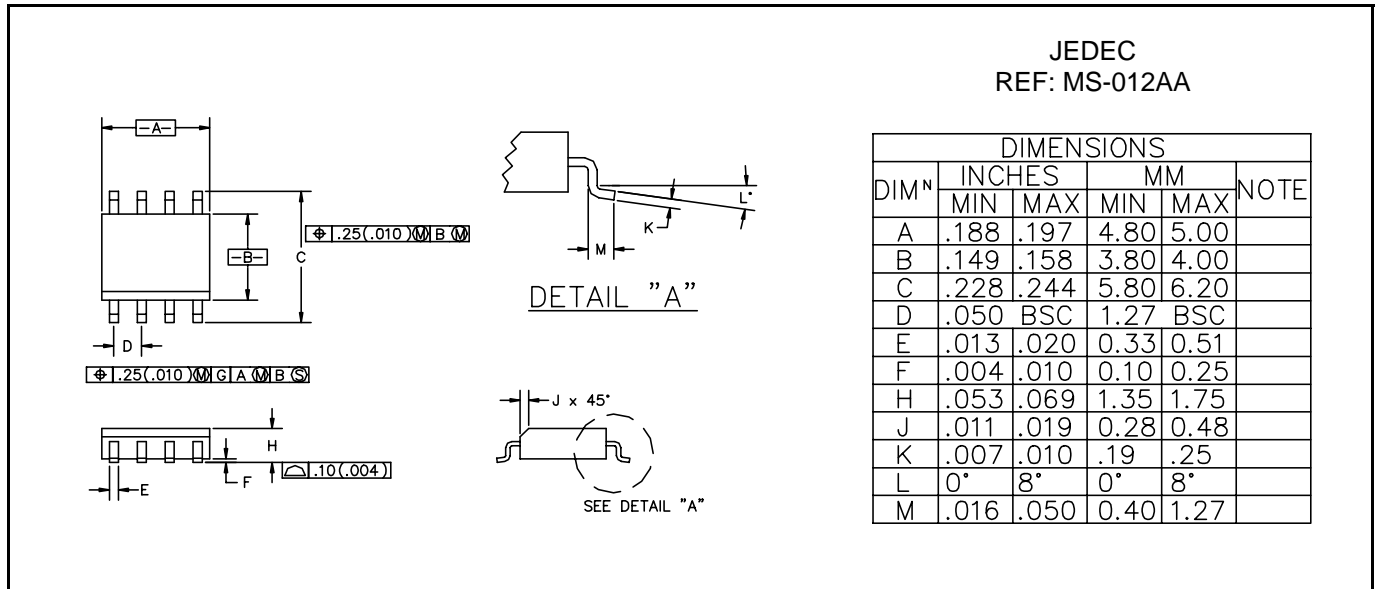
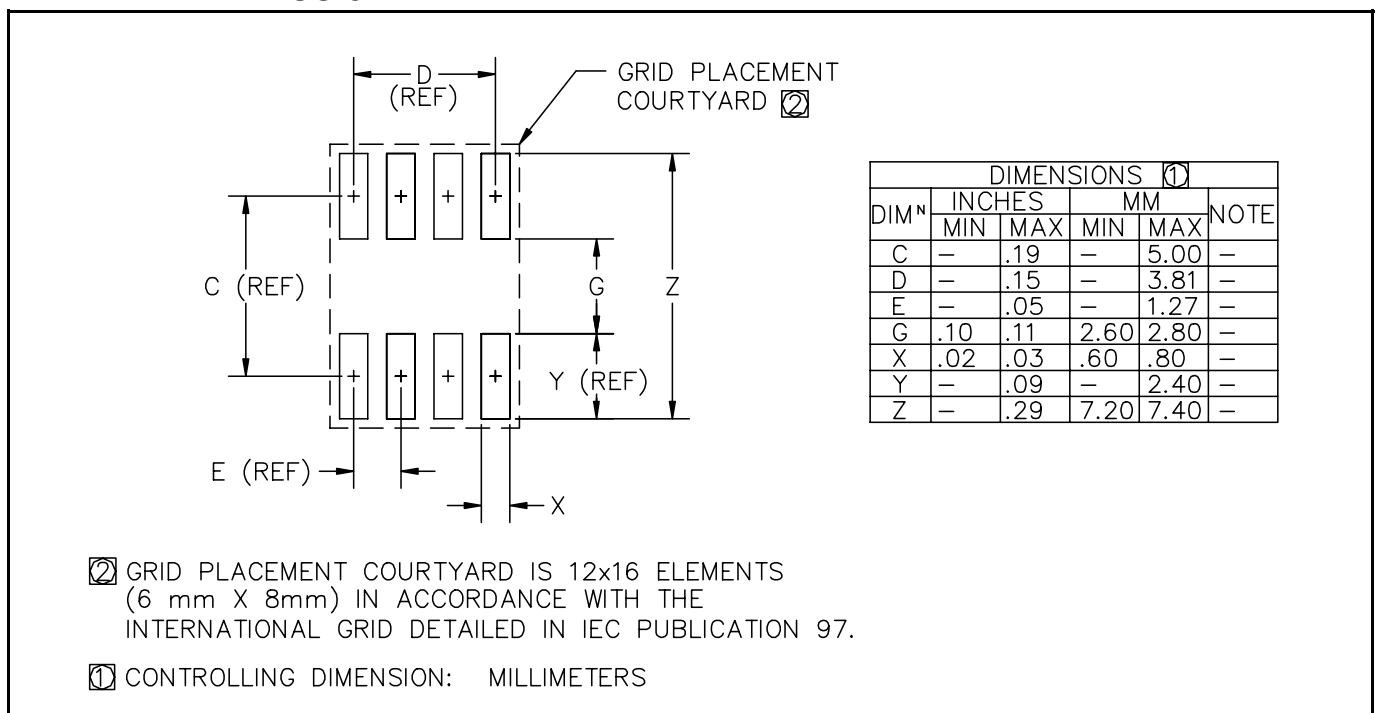
OUTLINE DRAWING - SO-8

LAND PATTERN - SO-8

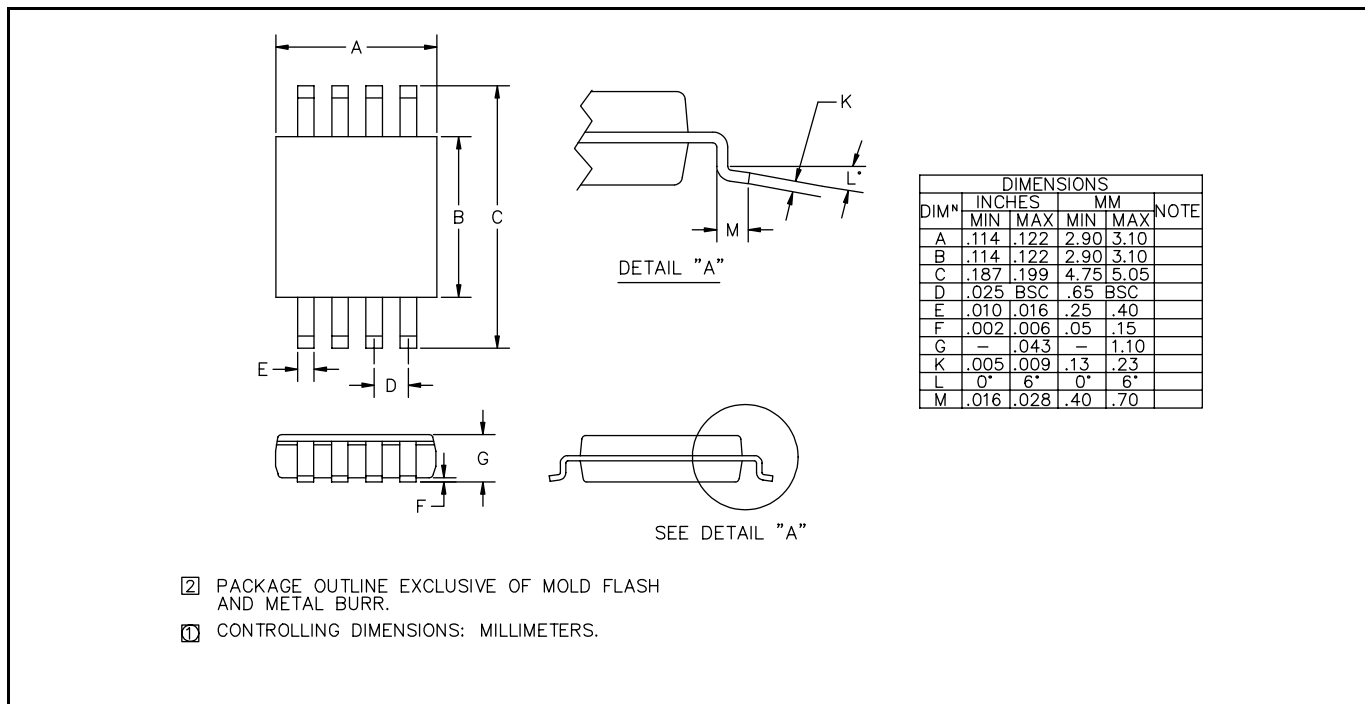
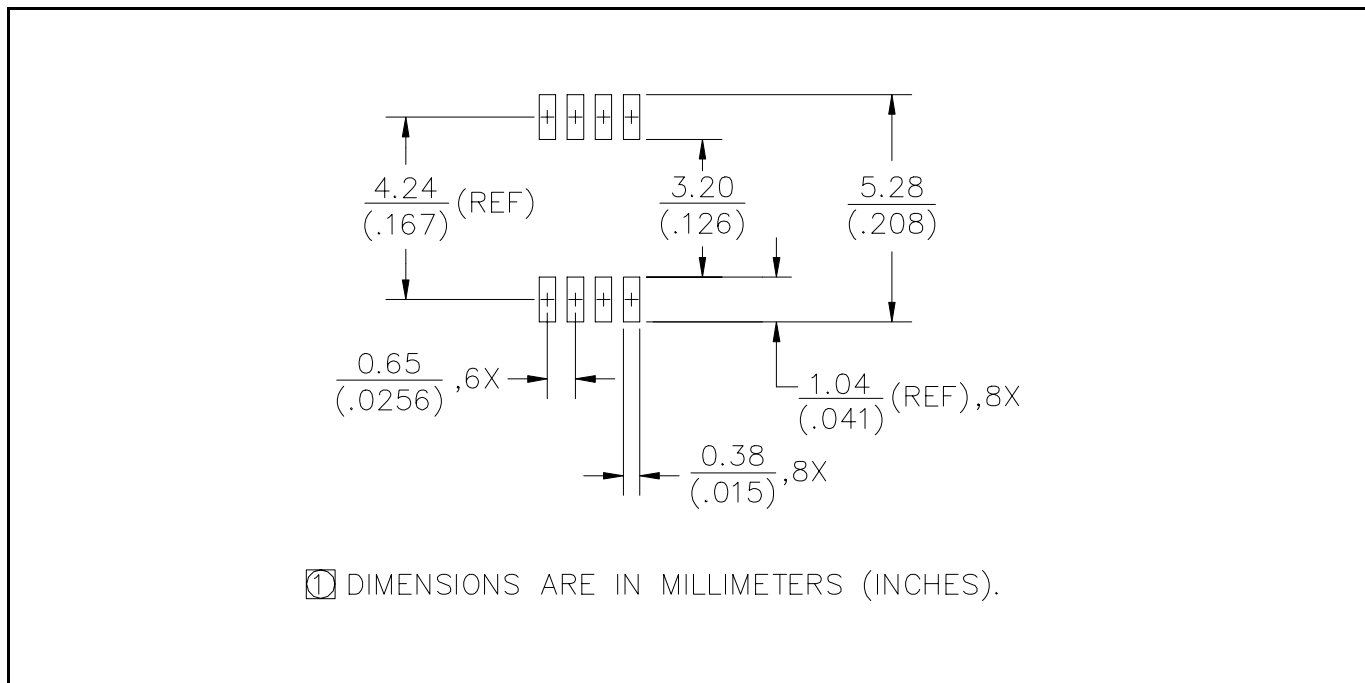
August 22, 2000

OUTLINE DRAWING - MSOP-8

LAND PATTERN - MSOP-8

ECN00-1275