

# DIESEL ENGINE-GENERATOR SET

## 750-XC6DT2

750 ekW / 60 Hz / Standby  
680 ekW / 60 Hz / Prime  
208 - 4160V



### SYSTEM RATINGS

#### Standby

Voltage (L-L)	208V**	240V**	480V**	600V**	4160V
Phase	3	3	3	3	3
PF	0.8	0.8	0.8	0.8	0.8
Hz	60	60	60	60	60
kW	750	750	750	750	750
kVA	937.5	937.5	937.5	937.5	937.5
AMPS	2602	2255	1128	902	130
skVA@30%					
Voltage Dip	2600	2600	2150	3100	1850
Generator Model*	574RSL4037	574RSL4037	573RSL4035	574RSS4278	574FSM4358
Temp Rise	130°C/27°C	130°C/27°C	130°C/27°C	125°C/40°C	130°C/27°C
Connection	12 LEAD LOW WYE	12 LEAD HI DELTA	12 LEAD HI WYE	4 LEAD WYE	6 LEAD WYE

#### Prime

Voltage (L-L)	208V	240V	480V	600V	4160V
Phase	3	3	3	3	3
PF	0.8	0.8	0.8	0.8	0.8
Hz	60	60	60	60	60
kW	680	680	680	680	680
kVA	850	850	850	850	850
AMPS	2359	2045	1022	818	118
skVA@30%					
Voltage Dip	2600	2600	2150	3100	1850
Generator Model*	574RSL4037	574RSL4037	573RSL4035	574RSS4278	574FSM4358
Temp Rise	105°C/40°C	105°C/40°C	105°C/40°C	105°C/40°C	105°C/40°C
Connection	12 LEAD LOW WYE	12 LEAD HI DELTA	12 LEAD HI WYE	4 LEAD WYE	6 LEAD WYE

\* The Generator Model Number identified in the table is for standard C Series Configuration. Consult the factory for alternate configuration.

\*\* UL2200 Offered

## FACTS

- // EPA Tier 2 Certified
- // Engine-Generator Set Tested to ISO 8528-5 for Transient Response
- // UL2200, CSA Listing Offered
- // Accepts Rated Load in One Step Per NFPA 110, Level 1
- // All engine-generator sets are prototype and factory tested
- // MTU Onsite Energy is a single source supplier
- // Global Product Support
- // 2 Year Standard Warranty
- // Custom Design for Any Application
- // 12V-2000 G84 Diesel Engine
  - 23.9 Liter Displacement
  - Electronic Unit Pump Injection
  - 4-Cycle
- // Complete Range of Accessories
- // Permanent Magnet Generator (PMG)
  - Brushless, Rotating Field
  - 300% Short Circuit Capability
  - 2/3 Pitch Windings
- // Digital Control Panel(s)
  - UL Recognized, c  us, NFPA 110
  - Complete System Metering
  - LCD Display
- // Cooling System
  - Integral Set-Mounted
  - Engine Driven Fan

## STANDARD EQUIPMENT

### // Engine

Air Cleaners  
 Oil Pump  
 Full Flow Oil Filter  
 Jacket Water Pump  
 Inter Cooler Water Pump  
 Thermostats  
 Exhaust Manifold - Dry  
 Blower Fan & Fan Drive  
 Radiator - Unit Mounted  
 Electric Starting Motor - 24V  
 Governor - Electric Isochronous  
 Base - Structural Steel  
 SAE Flywheel & Bell Housing  
 Charging Alternator - 24V  
 Battery Box & Cables  
 Flexible Fuel Connectors  
 Flexible Exhaust Connection  
 EPA Certified Engine

### // Generator

NEMA MG1, IEEE and ANSI standards compliance for temperature rise and motor starting  
 Sustained short circuit current of up to 300% of the rated current for up to 10 seconds  
 Self-Ventilated and Drip-Proof  
 Superior Voltage Waveform  
 Digital, Solid State, Volts-per-Hertz Regulator  
 No Load to Full Load Regulation

Brushless Alternator with Brushless Pilot Exciter  
 4 Pole, Rotating Field  
 130°C Standby Temperature Rise  
 1 Bearing, Sealed  
 Flexible Coupling  
 Full Amortisseur Windings  
 125% Rotor Balancing  
 3-Phase Voltage Sensing  
 ±.25% Voltage Regulation  
 100% of Rated Load - One Step  
 3% Maximum Harmonic Content

### // Digital Control Panel(s)

Digital Metering  
 Engine Parameters  
 Generator Protection Functions  
 Engine Protection  
 SAE J1939 Engine ECU Communications  
 Windows-Based Software  
 Multilingual Capability  
 Remote Communications to our RDP-110 Remote Annunciator  
 16 Programmable Contact Inputs  
 7 Contact Outputs  
 UL Recognized, c  us, CE Approved  
 Event Recording  
 IP 54 Front Panel Rating with Integrated Gasket  
 NFPA110 Level Compatible

## APPLICATION DATA

### // Engine

Manufacturer	MTU Detroit Diesel
Model	12V-2000 G84
Type	4-Cycle
Arrangement	12-V
Displacement: Cu In (lit)	1,458 (23.9)
Bore: in (cm)	5.1 (13)
Stroke: in (cm)	5.9 (15)
Compression Ratio	16:1
Rated RPM	1,800
Engine Governor	ADEC
Max Power: Standby: bhp (kWm)	1,119 (835)
Max Power: Prime: bhp (kWm)	1,020 (761)
Regulation	± 25%
Frequency	60 Hz
Air Cleaner	Dry

### // Liquid Capacity (Lubrication)

Total Oil System: gal (lit)	20.3 (77)
Engine Jacket Water Capacity: gal (lit)	29.1 (110)
After Cooler Water Capacity: gal (lit)	5.3 (20)
System Coolant Capacity: gal (lit)	91.1 (345)

### // Electrical

Electric Volts DC	24
Cold Cranking Amps Under 0°F (-17.8°C)	1,750

### // Fuel System

Fuel Supply Connection Size	3/4" NPT
Fuel Return Connection Size	1/4" NPT
Maximum Fuel Lift: ft (m)	10 (3)
Recommended Fuel	Diesel #2
Total Fuel Flow: gal/hr (lit/hr)	127 (480)

### // Fuel Consumption

	STANDBY	PRIME
At 100% of Power Rating: gal/hr (lit/hr)	52.4 (198)	48.9 (182)
At 75% of Power Rating: gal/hr (lit/hr)	41 (155)	37.7 (143)
At 50% of Power Rating: gal/hr (lit/hr)	27.7 (105)	25.4 (98)

### // Cooling - Radiator System

	STANDBY	PRIME
Ambient Capacity of Radiator: °F (°C)	104 (40)	104 (40)
Max. Restriction of Cooling Air, Intake, and Discharge Side of Rad.: in. H <sub>2</sub> O (kPa)	0.5 (0.12)	0.5 (0.12)
Water Pump Capacity: gpm (lit/min)	220 (833)	220 (833)
After Cooler Pump		
Capacity: gpm (lit/min)	68 (258)	68 (258)
Heat Rejection to Coolant: BTUM (kW)	18,767 (330)	17,060 (300)
Heat Rejection to After Cooler: BTUM (kW)	12,227 (215)	11,098 (195)
Heat Radiated to Ambient: BTUM (kW)	4,805 (84)	4,353 (76.5)

### // Air Requirements

	STANDBY	PRIME
Aspirating: *SCFM (m <sup>3</sup> /min)	2,225 (63)	2,119 (60)
Air Flow Required for Rad. Cooled Unit: *SCFM (m <sup>3</sup> /min)	39,990 (1,132)	39,990 (1,132)
Air Flow Required for Heat Exchanger/Remote Rad. based on 25°F Rise: *SCFM (m <sup>3</sup> /min)	10,837 (309)	9,817 (280)

\* Air density = 0.0739 lbm/ft<sup>3</sup> (1.184 kg/m<sup>3</sup>)

### // Exhaust System

	STANDBY	PRIME
Gas Temp. (Stack): °F (°C)	1,040 (560)	1,022 (550)
Gas Volume at Stack		
Temp: CFM (m <sup>3</sup> /min)	5,297 (150)	5,085 (144)
Maximum Allowable		
Back Pressure: in. H <sub>2</sub> O (kPa)	34.1 (8.5)	34.1 (8.5)

## WEIGHTS AND DIMENSIONS

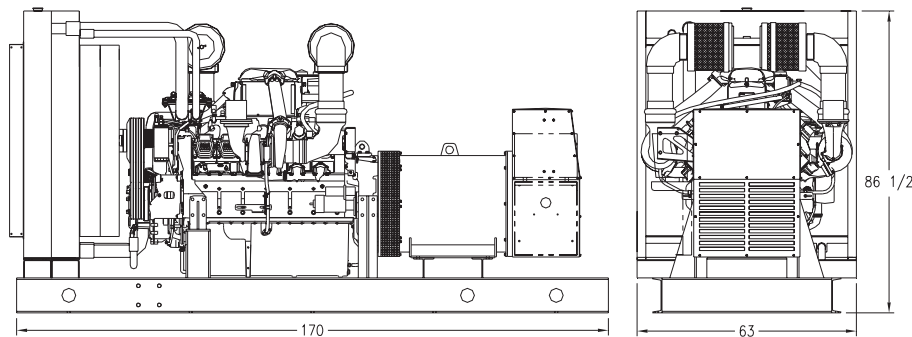

Drawing above for illustration purposes only, based on standard open power 480 volt generator. Lengths may vary with other voltages. Do not use for installation design.

System	Dimensions (L x W x H)	Weight (less tank)
OPU	170 x 63 x 86.5 in (4,320 x 1,600 x 2,200 mm)	12,108 lb (5,492 kg)

Weights and dimensions are based on open power units and are estimates only. Consult the factory for accurate weights and dimensions for your specific generator set.

## SOUND DATA

Unit Type	Standby Full Load	Standby No Load	Prime Full Load	Prime No Load
OPU w/Critical Grade Muffler (dBA)	100	93	98.5	93
Sound Attenuated Enclosure (dBA)	92	85	90.5	85

Measurements for sound data are taken at 23 ft (7 m).

## EMISSIONS DATA

NO <sub>x</sub> + NMHC	CO	PM
4.03	0.81	0.09

### All units are in g/hp-hr and are EPA D2 cycle values.

Emission levels of the engine may vary as a function of ambient temperature, barometric pressure, humidity, fuel type and quality, installation parameters, measuring instrumentation, etc. The data provided are laboratory results from one engine representing this rating. The data was obtained under controlled environmental conditions with calibrated instrumentation traceable to the United States National Bureau of Standards and in compliance with US EPA regulations found within 40 CFR Part 89. The weighted cycle value from each engine is guaranteed to be below the US EPA Standards at the US EPA defined conditions.

Materials and specifications subject to change without notice.

## RATING DEFINITIONS AND CONDITIONS

- // Ambient capability factor at 984 ft (300 m). Consult your local MTU Onsite Energy Power Generation Distributor for other altitudes.
- // Standby ratings apply to installations served by a reliable utility source. The standby rating is applicable to varying loads for the duration of a power outage. No overload capability for this rating. Ratings are in accordance with ISO-3046/1, BS 5514, AS 2789, and DIN 6271.
- // Prime power ratings apply to installations where utility power is unavailable or unreliable. At varying load, the number of generator set operating hours is unlimited. A 10% overload capacity is available for one hour in twelve. Ratings are in accordance with ISO-8528/1, overload power in accordance with ISO-3046/1, BS 5514, AS 2789, and DIN 6271. For limited running time and base load ratings, consult the factory.
- // Deration Factor:
  - Altitude:** No power decrease with increased elevation up to 5,906 ft (1,800 m)\* at 77°F (25°C).
  - Temperature:** 2.5% per 9°F (5°C) over 122°F (50°C) at 328 ft (100 m).
  - \*Contact factory for deration above 5,906 ft (1,800 m).