

PLEASE CHECK WWW.MOLEX.COM FOR LATEST PART INFORMATION

Part Number: [0986581211](#)
Status: **Active**
Overview: [mox crimp terminals](#)
Description: MOX Crimp Terminal, Female, 0.635mm (.025"), 20-24 AWG (0.22-0.60mm²), Reel, Tin (Sn)

Documents:

Packaging Specification (PDF)	Product Specification PS-98658-005 (PDF)
Drawing (PDF)	RoHS Certificate of Compliance (PDF)
Product Specification PS-500993-002 (PDF)	

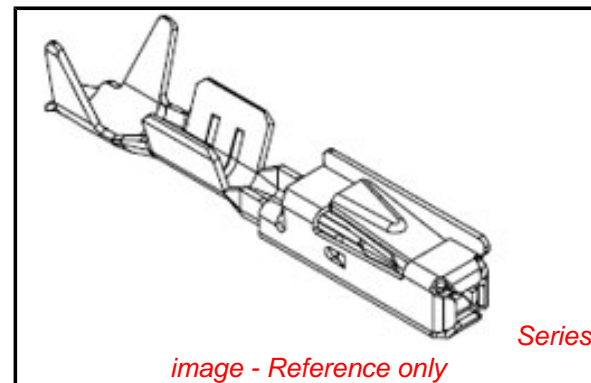

General

Product Family	Crimp Terminals
Series	98658
Comments	Terminal has Stainless Steel Sleeve
Crimp Quality Equipment	Yes
Overview	mox crimp terminals
Product Name	MOX

Physical

Durability (mating cycles max)	20
Gender	Female
Material - Metal	High Performance Alloy (HPA), Stainless Steel
Material - Plating Mating	Tin
Material - Plating Termination	Tin
Packaging Type	Reel
Plating min: Mating (µin)	40.00
Plating min: Mating (µm)	1.00
Plating min: Termination (µin)	40.00
Plating min: Termination (µm)	1.00
Termination Interface: Style	Crimp or Compression
Wire Insulation Diameter	1.20-1.80mm (.047-.071")
Wire Size AWG	N/A
Wire Size mm ²	0.22 TO 0.60

Electrical

Current - Maximum per Contact	7.5A
-------------------------------	------

Material Info

Reference - Drawing Numbers

Application Specification	AS-500993-001, AS-500993-002, AS-98944-005
Packaging Specification	PK-98658-006
Product Specification	PS-500993-002, PS-98658-005, RPS-500993-001
Sales Drawing	SD-98658-004

<p>EU RoHS ELV and RoHS Compliant REACH SVHC Contains SVHC: No Halogen-Free Status Halogen-Free</p>	<p>China RoHS</p>
--	--------------------------

Need more information on product environmental compliance?

Email productcompliance@molex.com
 For a multiple part number RoHS Certificate of Compliance, [click here](#)

Please visit the [Contact Us](#) section for any non-product compliance questions.

Search Parts in this Series
[98658Series](#)

Use With
 all 0.635mm (.025") MOX Housings

Application Tooling | [FAQ](#)
Tooling specifications and manuals are found by selecting the products below. Crimp Height Specifications are then contained in the Application Tooling Specification document.

Global Description	Product #
Extractor Tool for 2.8mm Crimp Terminals	0638136900
Extractor Tool for 2.8mm Crimp Terminals	0638137000
FineAdjust™ Applicator	0638666000
Hand Crimp Tool	0638119300
MOX Extraction Tool	0638132600

This document was generated on 05/31/2010

PLEASE CHECK WWW.MOLEX.COM FOR LATEST PART INFORMATION

FORME ADMISE
ALLOWED VERSION

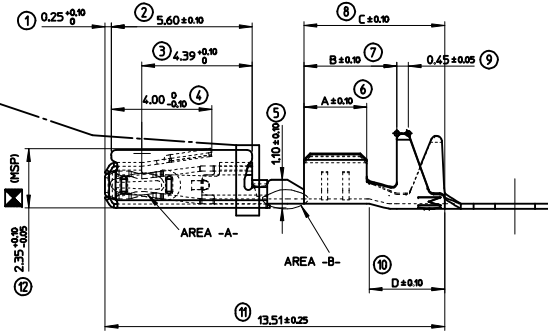

MOLEX REFERENCE	AREA -A- (GAP AREA)	AREA -B-	CRIMPING AREA	Wire size range	Longeure Length	Serrisage Wire Crimp	Conducteur Insulation Crimp	Serrisage Isolant Insulation Crimp	Poids Weight
TIN PLATED VERSION	096581211		HOT TIN DP Sn = 1.0 to 3.0 Hs						
GOLD PLATED VERSION	096581221	Au= 0.4 Hs MIN. Ni= 1.0 Hs MIN.		Sn = 1.0 to 5.0 Hs MIN. Ni = 1.0 Hs MIN.	0.22 to 0.60 mm2	A-250 B-370 C-560 D-300	E-190 F-240 Rc-050	G-290 H-280 Ri-080	0.6000 g
GOLD PLATED VERSION	096581231	Au= 0.4 Hs MIN. Ni= 1.0 Hs MIN.	Au= 0.4 Hs MIN. Ni= 1.0 Hs MIN.	Sn = 1.0 to 5.0 Hs MIN. Ni = 1.0 Hs MIN.					
TIN PLATED VERSION	096581212		HOT TIN DP Sn = 1.0 to 3.0 Hs						
GOLD PLATED VERSION	096581222	Au= 0.4 Hs MIN. Ni= 1.0 Hs MIN.		Sn = 1.0 to 5.0 Hs MIN. Ni = 1.0 Hs MIN.	0.75 mm2	A-280 B-370 C-560 D-270	E-225 F-225 Rc-050	G-290 H-280 Ri-080	
GOLD PLATED VERSION	096581232	Au= 0.4 Hs MIN. Ni= 1.0 Hs MIN.	Au= 0.4 Hs MIN. Ni= 1.0 Hs MIN.	Sn = 1.0 to 5.0 Hs MIN. Ni = 1.0 Hs MIN.					
TIN PLATED VERSION	096581213		HOT TIN DP Sn = 1.0 to 3.0 Hs						
GOLD PLATED VERSION	096581223	Au= 0.4 Hs MIN. Ni= 1.0 Hs MIN.		Sn = 1.0 to 5.0 Hs MIN. Ni = 1.0 Hs MIN.	0.22 to 0.50 mm2	A-250 B-370 C-560 D-300	E-180 F-180 Rc-040	G-230 H-230 Ri-070	
GOLD PLATED VERSION	096581233	Au= 0.4 Hs MIN. Ni= 1.0 Hs MIN.	Au= 0.4 Hs MIN. Ni= 1.0 Hs MIN.	Sn = 1.0 to 5.0 Hs MIN. Ni = 1.0 Hs MIN.					

X-X

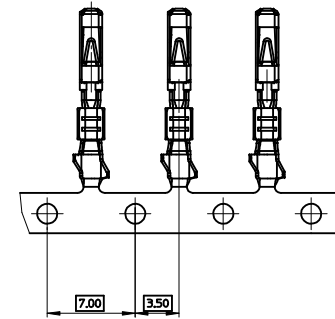
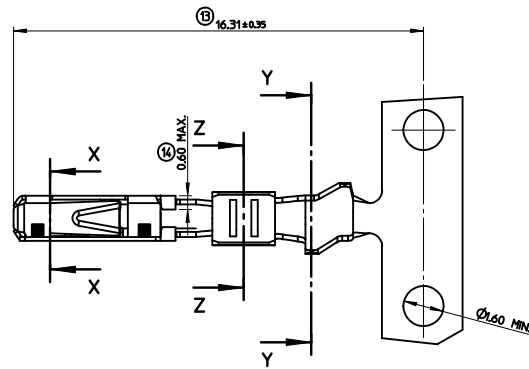
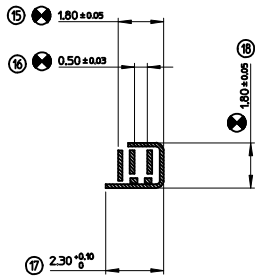

Z-Z

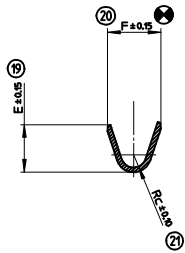

Y-Y

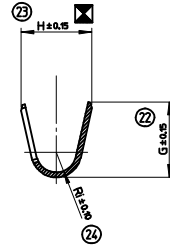

NOTE:

- MATERIAL: CONTACT BODY: HIGH CONDUCTIVE COPPER ALLOY.
SLEEVE: STAINLESS STEEL.
- PACKAGING SPECIFICATION: PK-98658-006.
- CRIMPING PARAMETERS AND CRIMPING TOOL DEFINITION: SEE CS-98658-001.

INDICATION DIMENSIONS S.P.C
DENOTES S.P.C DIMENSIONS
 INDICATION DIMENSIONS DETERMINANT LES
CAPABILITES MACHINE
DENOTES DIMENSIONS DETERMINING THE
MACHINE'S ABILITIES
 INDICATION DIMENSIONS FONCTIONNELLES
DENOTES FUNCTIONAL DIMENSIONS
 QUANTITE PAR FEUILLE INDIVIDUELLE
QUANTITY PER INDIVIDUAL SHEET
 - 2 - 4 - 0

CHANGED DR. E & F FOR 0.5 mmZ EC NO: GZ008-049Z DRAWING: GRANDCL 2008/12/04 CHKD: MANDRE 2008/12/02 APPR: LSTLEKER 2008/12/08	GENERAL TOLERANCES (UNLESS SPECIFIED)	DIMENSION STYLE MM ONLY	SCALE 10:1	DESIGN UNITS METRIC	<input checked="" type="checkbox"/> FIRST ANGLE PROJECTION	
	4 PLACES ± --- ± --- 3 PLACES ± --- ± --- 2 PLACES ± 0. ± --- 1 PLACE ± 0. ± ---	mm INCH ± --- ± --- ± --- ± --- ± 0. ± --- ± 0. ± ---	DRAWN BY DATE JTAMSSON 1998/06/01 CHECKED BY DATE MANDRE 1999/10/14 APPROVED BY DATE CBOUCHAN 1999/10/14	TITLE MOX 0.63 TERMINAL RECEPTACLE TERMINAL GENERIC CONTROL DRAWING	MOLEX INCORPORATED	SHEET NO. 1 OF 1
	ANGULAR ± 1/2°	DRAFT WHERE APPLICABLE MUST REMAIN WITHIN DIMENSIONS	MATERIAL NO. SEE CHART	DOCUMENT NO. SD-98658-004	<input checked="" type="checkbox"/> MOLEX INCORPORATED	INCORPORATED AND SHOULD NOT BE USED WITHOUT WRITTEN PERMISSION
	REV	DESCRIPTION	SIZE A1	THIS DRAWING CONTAINS INFORMATION THAT IS PROPRIETARY TO MOLEX INCORPORATED AND SHOULD NOT BE USED WITHOUT WRITTEN PERMISSION	MOLEX INCORPORATED	SHEET NO. 1 OF 1