

S G S-THOMSON

30E D

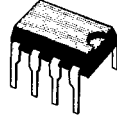
DUAL HIGH PERFORMANCE OPERATIONAL AMPLIFIER

- SINGLE OR SPLIT SUPPLY OPERATION
- LOW POWER CONSUMPTION
- HIGH UNITY GAIN BANDWIDTH
- NO CROSSOVER DISTORSION
- NO POP NOISE
- SHORT-CIRCUIT PROTECTION
- HIGH CHANNEL SEPARATION

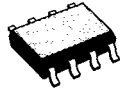
in low noise audio signal processing application. The optimized class AB output stage completely eliminates crossover, distortion, under any load conditions, has large source and sink capacity and is short-circuit protected.

DESCRIPTION

The LS4558N is a high performance dual operational amplifier with frequency and phase compensation built into the chip. The internal phase compensation allows stable operation as voltage follower in spite of its high gain-bandwidth products. The circuit presents very stable electrical characteristics over the entire supply voltage range and the specially designed input stage allow the LS4558N to be used



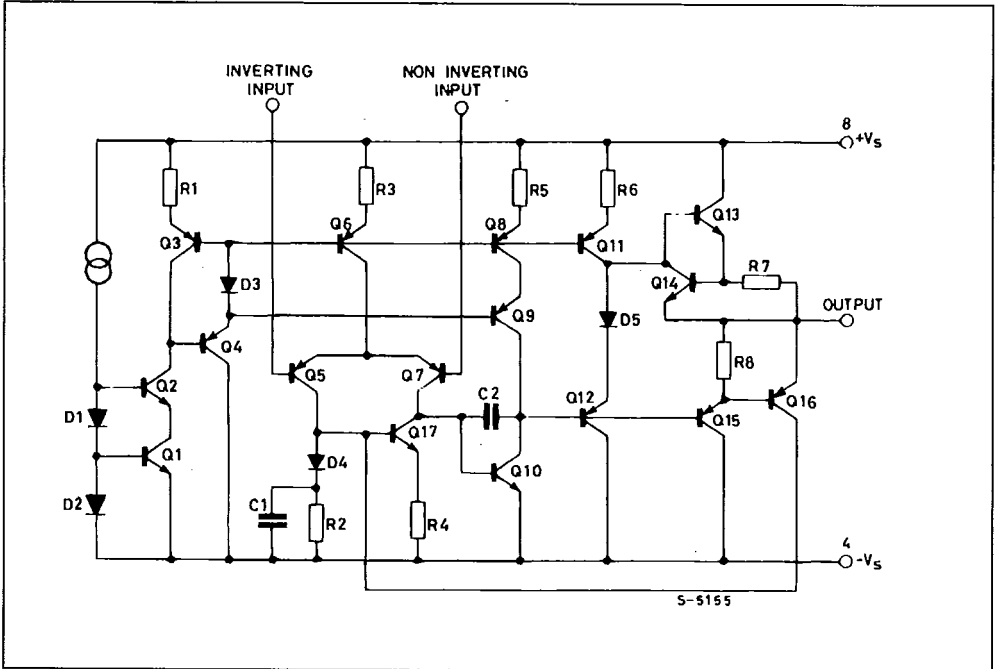
Minidip



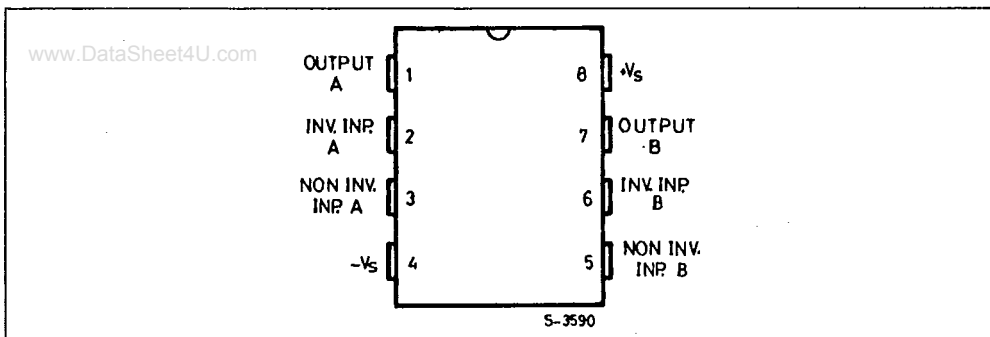
SO-8J

ORDER CODES : LS4558NB (Minidip)
LS4558NM (SO-8J)

SCHEMATIC DIAGRAM (one section)



CONNECTION DIAGRAM (top view)



ABSOLUTE MAXIMUM RATINGS

| Symbol | Parameter | Value | Unit | |
|-----------|---|-------------------------|------------------|----------|
| V_s | Supply Voltage | ± 18 | V | |
| V_i | Input Voltage | $\pm V_s$ | | |
| V_d | Differential Input Voltage | $\pm (V_s - 1)$ | V | |
| P_{tot} | Power Dissipation at $T_{amb} = 70^\circ\text{C}$ | Minidip Micropackage | 665 400 | mW mW |
| T_{op} | Operating Temperature | 0 to 70 | $^\circ\text{C}$ | |
| T_j | Junction Temperature | 150 | $^\circ\text{C}$ | |
| T_{stg} | Storage Temperature | -55 to 150 | $^\circ\text{C}$ | |

THERMAL DATA

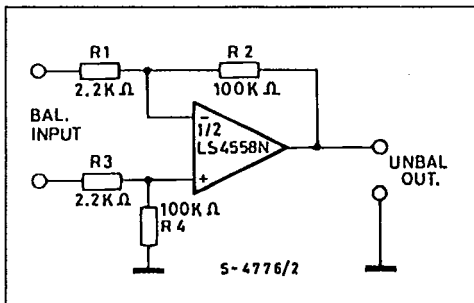
S G S-THOMSON

SOE D

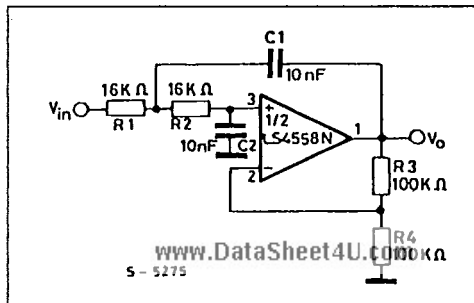
| | | Minidip | SO-8 |
|-----------------|-------------------------------------|------------------------|------------------------|
| $R_{th(j-amb)}$ | Thermal Resistance Junction-ambient | 120 $^\circ\text{C/W}$ | 200 $^\circ\text{C/W}$ |

TYPICAL APPLICATIONS

Balanced Input Audio Preamplifier.



DC Coupled Low-pass Active Filter
($f = 1\text{ KHz}$, $G_v = 6\text{ dB}$).



ELECTRICAL CHARACTERISTICS ($V_s = \pm 15\text{ V}$, $T_{\text{amb}} = 25^\circ\text{C}$, unless otherwise specified)

| Symbol | Parameter | | Test Conditions | Min. | Typ. | Max. | Unit |
|----------|-------------------------------------|-----------|---|------|---------------|------|--------------------------|
| I_s | Supply Current (*) | | | | 1 | 2 | mA |
| I_b | Input Bias Current | | | | 50 | 500 | nA |
| | | | $T_{\text{min}} < T_{\text{op}} < T_{\text{max}}$ | | | 800 | nA |
| R_i | Input Resistance | | $f = 1\text{ KHz}$ | 0.3 | 1 | | M Ω |
| V_{os} | Input Offset Voltage | | $R_g \leq 10\text{ K}\Omega$ | | 0.5 | 5 | mV |
| | | | $R_g \leq 10\text{ K}\Omega$ | | | 7.5 | mV |
| | | | $T_{\text{min}} < T_{\text{op}} < T_{\text{max}}$ | | | | |
| I_{os} | Input Offset Current | | | | 20 | 200 | nA |
| | | | $T_{\text{min}} < T_{\text{op}} < T_{\text{max}}$ | | | 500 | nA |
| I_{sc} | Output Short Circuit Current | | | | 23 | | mA |
| G_v | Large Signal Open Loop Voltage Gain | | $R_L = 2\text{ K}\Omega$ | 86 | 100 | | dB |
| B | Gain-bandwidth Product | | $f = 20\text{ KHz}$ | 2 | 3 | | MHz |
| e_N | Total Input Noise Voltage | | $f = 1\text{ KHz}$ $R_g = 50\text{ }\Omega$ $R_g = 1\text{ K}\Omega$ $R_g = 10\text{ K}\Omega$ | | 8 10 18 | 15 | nV $\sqrt{\text{Hz}}$ |
| e_N | Popcorn Noise | | $B = 1\text{ Hz to }1\text{ KHz}$ $R_g = 10\text{ K}\Omega$ $t = 10\text{ sec}$ | | | 10 | $\mu\text{V Peak}$ |
| d | Distortion | | $G_v = 20\text{ dB}$ $V_o = 2\text{ Vpp}$ $R_L = 2\text{ K}\Omega$ $f = 1\text{ KHz}$ | | 0.03 | | % |
| V_o | Output Voltage Swing | | $R_L = 2\text{ K}\Omega$ | | ± 13 | | V |
| V_o | Large Signal Voltage Swing | | $R_L = 10\text{ K}\Omega$ $f = 10\text{ KHz}$ | | 28 | | Vpp |
| | Transient Response | Rise Time | $V_i = 20\text{ mV}$ $R_L = 2\text{ K}\Omega$ $C_L = 100\text{ pF}$ | | 0.13 | | μs |
| | | Overshoot | | | 5 | | % |
| SR | Slew Rate | | Unity Gain $R_L = 2\text{ K}\Omega$ | 0.8 | 1.5 | | V/ μs |
| CMR | Common Mode Rejection | | $V_i = 10\text{ V}$ $T_{\text{min}} < T_{\text{op}} < T_{\text{max}}$ | 70 | 90 | | dB |
| SVR | Supply Voltage Rejection | | $V_i = 1\text{ V}$ $T_{\text{min}} < T_{\text{op}} < T_{\text{max}}$ $f = 100\text{ Hz}$ | | | | dB |
| CS | Channel Separation | | $f = 10\text{ KHz}$ $R_g = 1\text{ K}\Omega$ | | 105 | | dB |

(*) Both amplifiers.

Figure 1 : Open Loop Frequency and Phase Response.

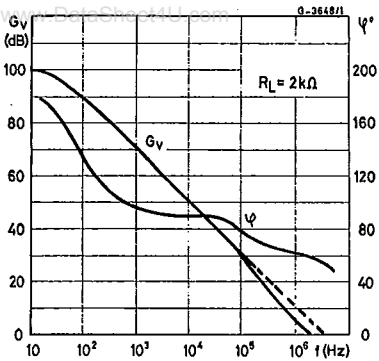


Figure 3 : Supply Voltage Rejection vs. Frequency

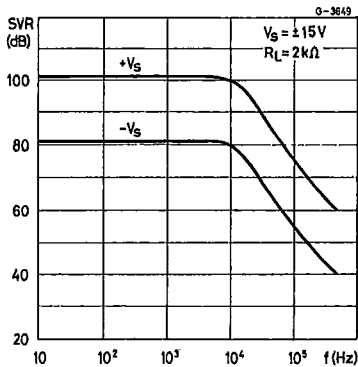


Figure 5 : Output Voltage Swing vs. Load Resistance.

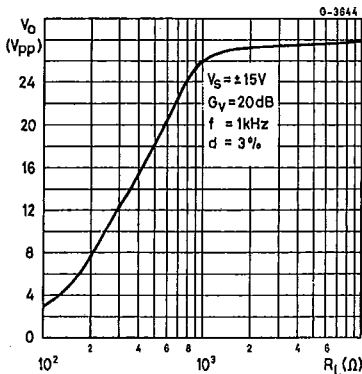


Figure 2 : Open Loop Gain vs. Ambient Temperature.

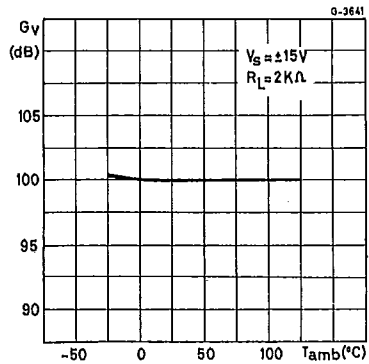


Figure 4 : Large Signal Frequency Response

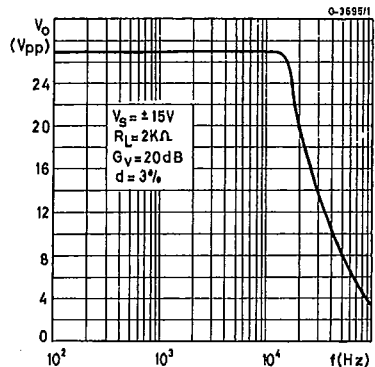


Figure 6 : Total Input Noise vs. Frequency.

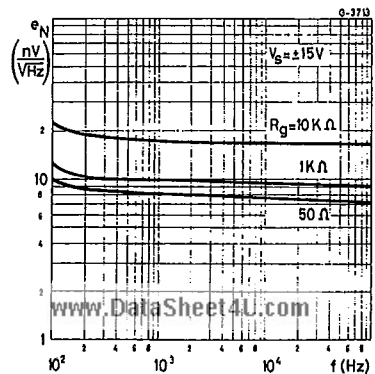


Figure 7 : Channel Separation.

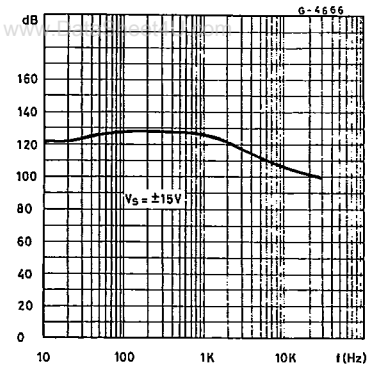


Figure 8 : Transient Response.

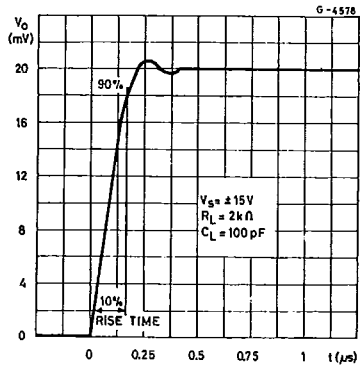
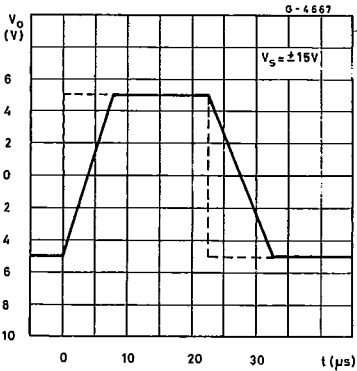


Figure 9 : Voltage Follower Large-signal Pulse Response.

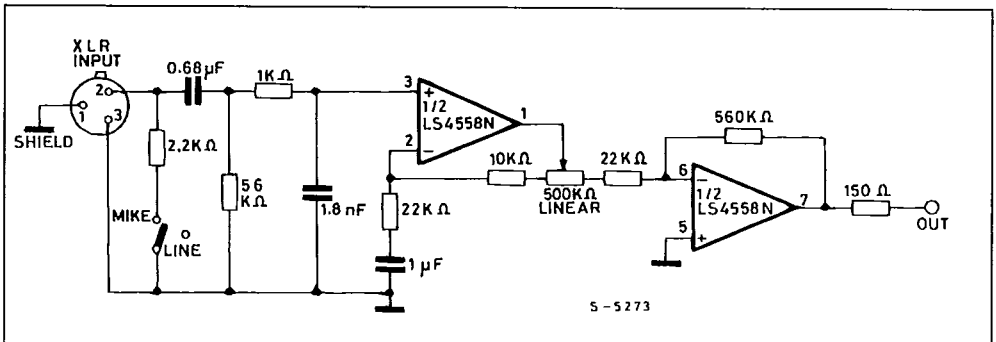


SGS-THOMSON

30E D

APPLICATION INFORMATION

Figure 10 : Mike/Line Preamp for Audio Mixers (0 dB to 60 dB continuously variable gain).



Note : The particular characteristics of the circuit of Figure 10 is that using a linear potentiometer, the gain is continuously variable in a logarithmic mode from 0 dB to 60 dB in the audio band.

www.DataSheet4U.com

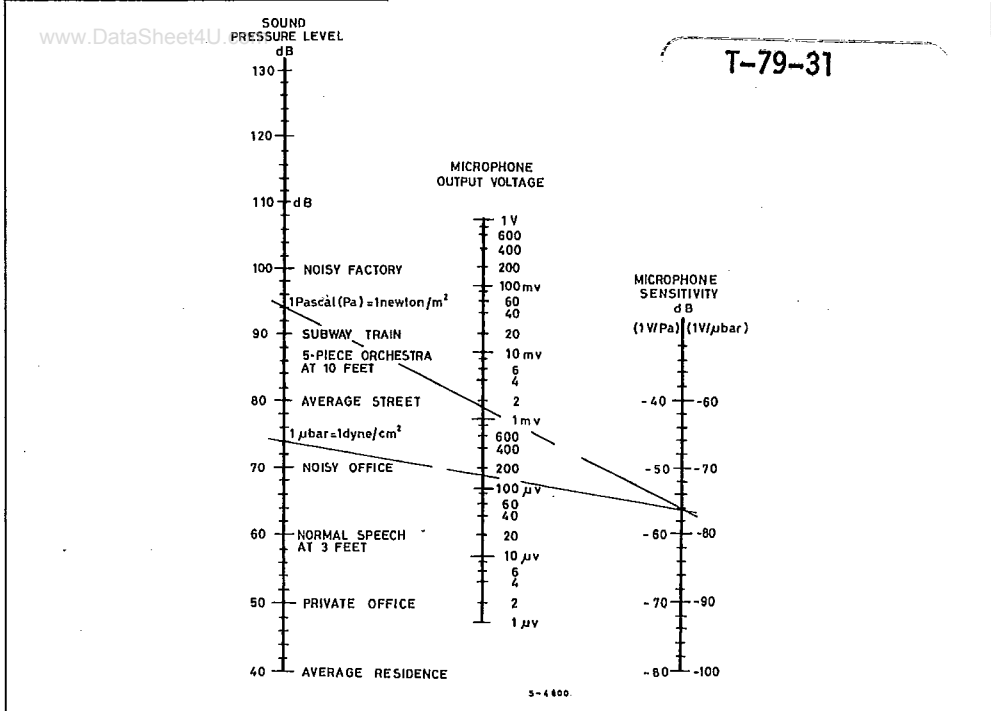
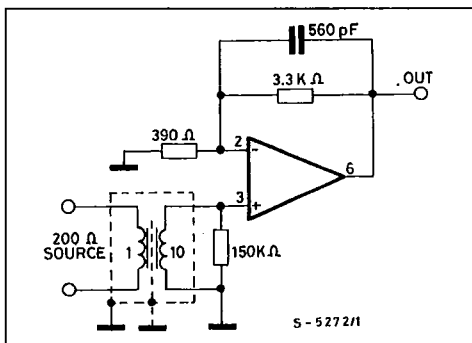
Figure 12 : Very Low-noise Mike Preampifier ($G_V = 40$ dB).

Figure 13 : Balanced Input Audio Preampifier.

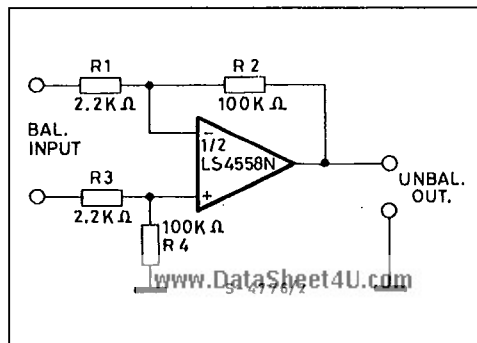


Figure 14 : 20 Hz to 200 Hz Variable High-pass Filter ($G_v = 3$ dB).

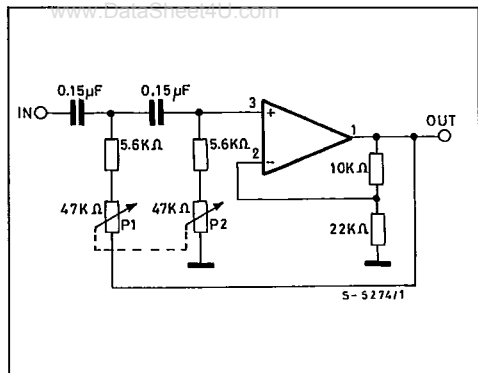


Figure 15 : Frequency Response of the High-pass Filter of Figure 14.

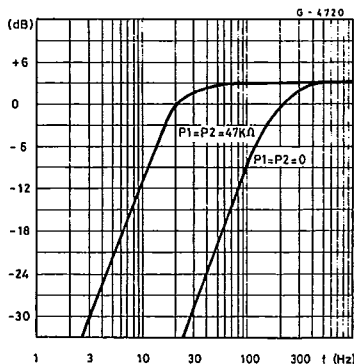


Figure 16 : DC Coupled Low-pass Active Filter ($f = 1$ KHz, $G_v = 6$ dB).

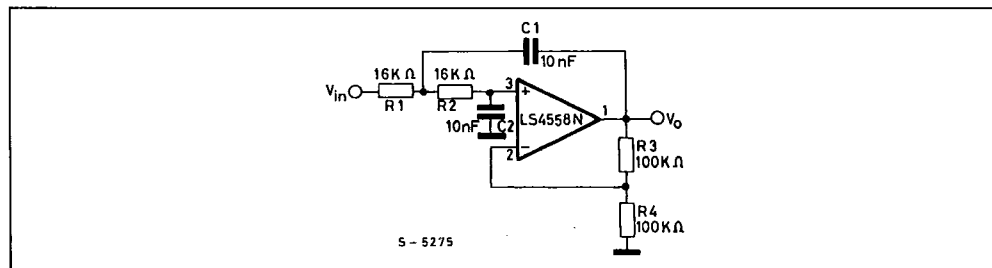


Figure 17 : Switchable HP-LP Audio Filter. S G S-THOMSON

30E

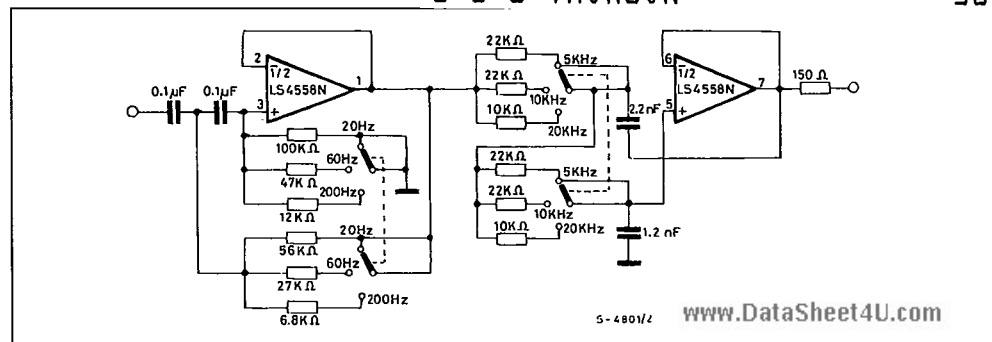


Figure 18 : Subsonic or Rumble Filter (Gv = 0 dB).

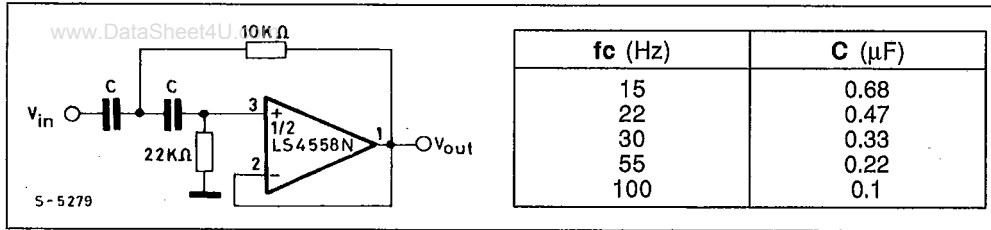


Figure 19 : High-cut Filter (Gv = 0 dB).

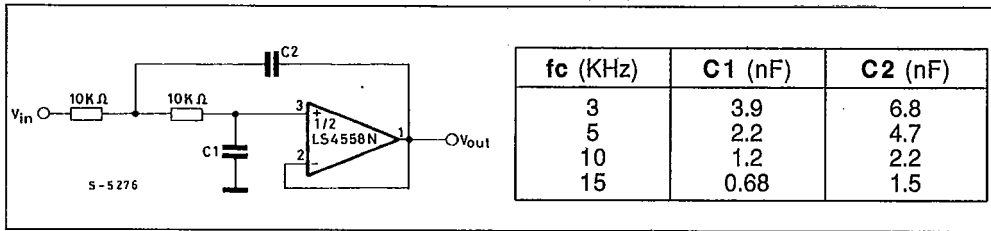
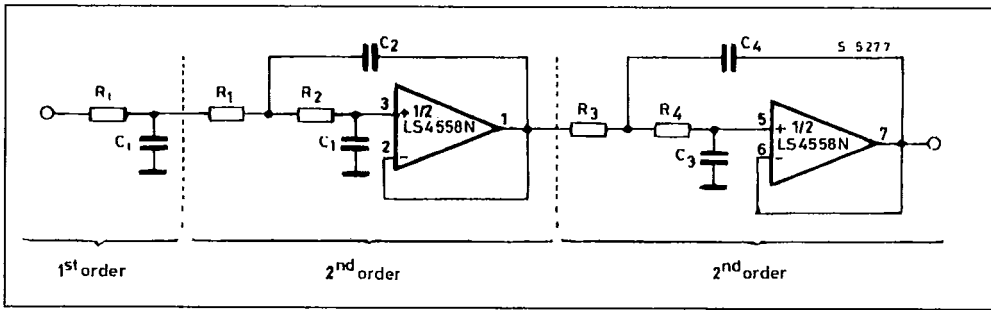


Figure 20 : Fifth Order 3.4 KHz Low-pass Butterworth Filter.



For $f_c = 3.4$ KHz and $R1 = R2 = R3 = R4 = R5 = 10$ KΩ, we obtain :

$$C1 = 1.354 \cdot \frac{1}{R} \cdot \frac{1}{2\pi f_c} = 6.33 \text{ nF}$$

$$C1 = 0.309 \cdot \frac{1}{R} \cdot \frac{1}{2\pi f_c} = 1.45 \text{ nF}$$

$$C1 = 0.421 \cdot \frac{1}{R} \cdot \frac{1}{2\pi f_c} = 1.97 \text{ nF}$$

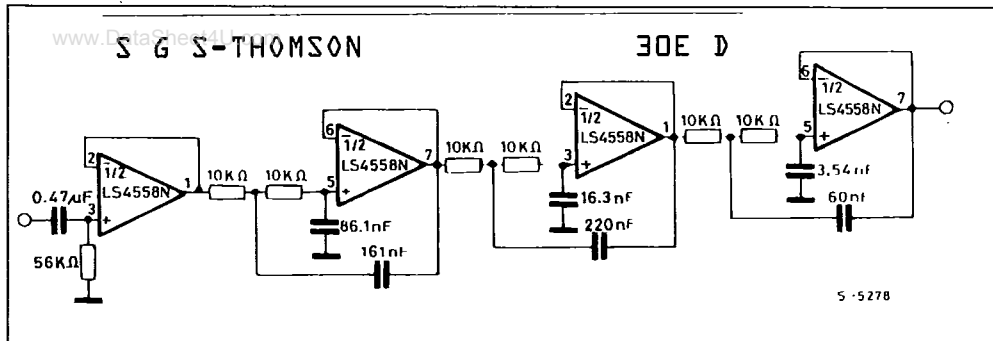
$$C1 = 3.325 \cdot \frac{1}{R} \cdot \frac{1}{2\pi f_c} = 15.14 \text{ nF}$$

$$C1 = 1.753 \cdot \frac{1}{R} \cdot \frac{1}{2\pi f_c} = 8.20 \text{ nF}$$

The attenuation of the DataSheet4U.com is better than 60 dB at 15 KHz.

Figure 21 : Six-pole 355 Hz Low-pass Filter (Chebychev type).

T-79-31



This is a 6-pole Chebychev type with ± 0.25 dB ripple in the passband. A decoupling stage is used to avoid the influence of the input impedance on the filter's characteristics. The attenuation is about 55 dB at 710 Hz and reaches 90 dB at 1 kHz. The attenuation is limited in practice to the ± 0.25 dB ripple and does not exceed 0.5 dB at 0.9 fc.