

# User's Manual

# IE-78078-NS-EM1

## Emulation Board

---

### Target Devices

**μPD78075B Subseries**

**μPD78078 Subseries**

**μPD78078Y Subseries**

**μPD78083 Subseries**

**μPD78070A**

**μPD78070AY**

**[MEMO]**

**Windows is either a registered trademark or a trademark of Microsoft Corporation in the United States and/or other countries.**

**PC/AT is a trademark of International Business Machines Corporation.**

- **The information in this document is current as of August, 2000. The information is subject to change without notice. For actual design-in, refer to the latest publications of NEC's data sheets or data books, etc., for the most up-to-date specifications of NEC semiconductor products. Not all products and/or types are available in every country. Please check with an NEC sales representative for availability and additional information.**
  - No part of this document may be copied or reproduced in any form or by any means without prior written consent of NEC. NEC assumes no responsibility for any errors that may appear in this document.
  - NEC does not assume any liability for infringement of patents, copyrights or other intellectual property rights of third parties by or arising from the use of NEC semiconductor products listed in this document or any other liability arising from the use of such products. No license, express, implied or otherwise, is granted under any patents, copyrights or other intellectual property rights of NEC or others.
  - Descriptions of circuits, software and other related information in this document are provided for illustrative purposes in semiconductor product operation and application examples. The incorporation of these circuits, software and information in the design of customer's equipment shall be done under the full responsibility of customer. NEC assumes no responsibility for any losses incurred by customers or third parties arising from the use of these circuits, software and information.
  - While NEC endeavours to enhance the quality, reliability and safety of NEC semiconductor products, customers agree and acknowledge that the possibility of defects thereof cannot be eliminated entirely. To minimize risks of damage to property or injury (including death) to persons arising from defects in NEC semiconductor products, customers must incorporate sufficient safety measures in their design, such as redundancy, fire-containment, and anti-failure features.
  - NEC semiconductor products are classified into the following three quality grades:  
"Standard", "Special" and "Specific". The "Specific" quality grade applies only to semiconductor products developed based on a customer-designated "quality assurance program" for a specific application. The recommended applications of a semiconductor product depend on its quality grade, as indicated below. Customers must check the quality grade of each semiconductor product before using it in a particular application.
    - "Standard": Computers, office equipment, communications equipment, test and measurement equipment, audio and visual equipment, home electronic appliances, machine tools, personal electronic equipment and industrial robots
    - "Special": Transportation equipment (automobiles, trains, ships, etc.), traffic control systems, anti-disaster systems, anti-crime systems, safety equipment and medical equipment (not specifically designed for life support)
    - "Specific": Aircraft, aerospace equipment, submersible repeaters, nuclear reactor control systems, life support systems and medical equipment for life support, etc.
- The quality grade of NEC semiconductor products is "Standard" unless otherwise expressly specified in NEC's data sheets or data books, etc. If customers wish to use NEC semiconductor products in applications not intended by NEC, they must contact an NEC sales representative in advance to determine NEC's willingness to support a given application.
- (Note)
- (1) "NEC" as used in this statement means NEC Corporation and also includes its majority-owned subsidiaries.
  - (2) "NEC semiconductor products" means any semiconductor product developed or manufactured by or for NEC (as defined above).

M8E 00.4

# Regional Information

Some information contained in this document may vary from country to country. Before using any NEC product in your application, please contact the NEC office in your country to obtain a list of authorized representatives and distributors. They will verify:

- Device availability
- Ordering information
- Product release schedule
- Availability of related technical literature
- Development environment specifications (for example, specifications for third-party tools and components, host computers, power plugs, AC supply voltages, and so forth)
- Network requirements

In addition, trademarks, registered trademarks, export restrictions, and other legal issues may also vary from country to country.

**NEC Electronics Inc. (U.S.)**

Santa Clara, California  
Tel: 408-588-6000  
800-366-9782  
Fax: 408-588-6130  
800-729-9288

**NEC Electronics (Germany) GmbH**

Duesseldorf, Germany  
Tel: 0211-65 03 02  
Fax: 0211-65 03 490

**NEC Electronics (UK) Ltd.**

Milton Keynes, UK  
Tel: 01908-691-133  
Fax: 01908-670-290

**NEC Electronics Italiana s.r.l.**

Milano, Italy  
Tel: 02-66 75 41  
Fax: 02-66 75 42 99

**NEC Electronics (Germany) GmbH**

Benelux Office  
Eindhoven, The Netherlands  
Tel: 040-2445845  
Fax: 040-2444580

**NEC Electronics (France) S.A.**

Velizy-Villacoublay, France  
Tel: 01-30-67 58 00  
Fax: 01-30-67 58 99

**NEC Electronics (France) S.A.**

Madrid Office  
Madrid, Spain  
Tel: 91-504-2787  
Fax: 91-504-2860

**NEC Electronics (Germany) GmbH**

Scandinavia Office  
Taebby, Sweden  
Tel: 08-63 80 820  
Fax: 08-63 80 388

**NEC Electronics Hong Kong Ltd.**

Hong Kong  
Tel: 2886-9318  
Fax: 2886-9022/9044

**NEC Electronics Hong Kong Ltd.**

Seoul Branch  
Seoul, Korea  
Tel: 02-528-0303  
Fax: 02-528-4411

**NEC Electronics Singapore Pte. Ltd.**

United Square, Singapore  
Tel: 65-253-8311  
Fax: 65-250-3583

**NEC Electronics Taiwan Ltd.**

Taipei, Taiwan  
Tel: 02-2719-2377  
Fax: 02-2719-5951

**NEC do Brasil S.A.**

Electron Devices Division  
Guarulhos-SP Brasil  
Tel: 55-11-6462-6810  
Fax: 55-11-6462-6829

# INTRODUCTION

## Product Overview

The IE-78078-NS-EM1 is designed to be used with the IE-78K0-NS to debug the following target devices that belong to the 78K/0 Series of 8-bit single-chip microcontrollers.

- $\mu$ PD78075B Subseries:  $\mu$ PD78074B, 78075B
- $\mu$ PD78078 Subseries:  $\mu$ PD78076, 78078
- $\mu$ PD78078Y Subseries:  $\mu$ PD78076Y, 78078Y
- $\mu$ PD78083 Subseries:  $\mu$ PD78081, 78082
- $\mu$ PD78070A
- $\mu$ PD78070AY

## Target Readers

This manual is intended for engineers who will use the IE-78078-NS-EM1 with the IE-78K0-NS to perform system debugging.

Engineers who use this manual are expected to be thoroughly familiar with the target device's functions and use methods and to be knowledgeable about debugging.

## Organization

When using the IE-78078-NS-EM1, refer to not only this manual (supplied with the IE-78078-NS-EM1) but also the manual that is supplied with the IE-78K0-NS.

IE-78K0-NS User's Manual
-----------------------------

- Basic specifications
- System configuration
- External interface functions

IE-78078-NS-EM1 User's Manual
----------------------------------

- General
- Part names
- Installation
- Differences between target devices and target interface circuits

## Purpose

This manual's purpose is to explain various debugging functions that can be performed when using the IE-78078-NS-EM1.

## Terminology

The meanings of certain terms used in this manual are listed below.

Term	Meaning
Emulation device	This is a general term that refers to the device in the emulator that is used to emulate the target device. It includes the emulation CPU.
Emulation CPU	This is the CPU block in the emulator that is used to execute user-generated programs.
Target device	This is the device (real chip) that is the target for emulation.
Target system	This includes the target program and the hardware provided by the user. When defined narrowly, it includes only the hardware.
IE system	This refers to the combination of the IE-78K0-NS and the IE-78078-NS-EM1.

## Conventions

Data significance: Higher digits on the left and lower digits on the right

**Note:** Footnote for item marked with **Note** in the text

**Caution:** Information requiring particular attention

**Remark:** Supplementary information

## Related Documents

The related documents (user's manuals) indicated in this publication may include preliminary versions. However, preliminary versions are not marked as such.

Document Name	Document Number
IE-78K0-NS	U13731E
IE-78078-NS-EM1	This manual
ID78K0-NS Integrated Debugger Reference (Windows™ Based)	U12900E
μPD78075B, 78075BY Subseries	U12560E
μPD78078, 78078Y Subseries	U10641E
μPD78083 Subseries	U12176E
μPD78070A, 78070AY	U10200E

**Caution** The documents listed above are subject to change without notice. Be sure to use the latest documents when designing.

## CONTENTS

<b>CHAPTER 1 GENERAL</b> .....	<b>11</b>
1.1 System Configuration .....	12
1.2 Hardware Configuration.....	14
1.3 Basic Specifications.....	15
1.4 Cautions on $\mu$ PD78070A and 78070AY Development .....	16
<b>CHAPTER 2 PART NAMES</b> .....	<b>19</b>
2.1 Parts of Main Unit .....	20
<b>CHAPTER 3 INSTALLATION</b> .....	<b>21</b>
3.1 Connection .....	22
3.2 Clock Settings.....	23
3.2.1 Overview of clock settings .....	23
3.2.2 Main system clock settings.....	26
3.2.3 Subsystem clock settings .....	31
3.3 Low-Voltage Emulation Setting.....	36
3.4 External Trigger .....	37
3.5 Jumper Settings.....	38
<b>CHAPTER 4 DIFFERENCES BETWEEN TARGET     DEVICES AND TARGET INTERFACE CIRCUITS</b> .....	<b>39</b>
<b>APPENDIX EMULATION PROBE PIN ASSIGNMENT TABLE</b> .....	<b>45</b>

## LIST OF FIGURES

Figure No.	Title	Page
1-1	System Configuration.....	12
1-2	Basic Hardware Configuration .....	14
2-1	IE-78078-NS-EM1 Part Names .....	20
3-1	Connection of Emulation Probe.....	22
3-2	External Circuits Used as System Clock Oscillator.....	23
3-3	When Using Clock That Is Already Mounted on Emulation Board (Main System Clock).....	24
3-4	When Using Clock That Is Already Mounted on Emulation Board (Subsystem Clock) .....	24
3-5	When Using User-Mounted Clock (Main System Clock) .....	25
3-6	When Using User-Mounted Clock (Subsystem Clock) .....	25
3-7	When Using External Clock .....	26
3-8	Connections on Parts Board (When Using Main System Clock or User-Mounted Clock) .....	27
3-9	Crystal Oscillator (When Using Main System Clock or User-Mounted Clock).....	29
3-10	Pin Alignment of Crystal Oscillator and Socket .....	29
3-11	Connections on Parts Board (When Using Subsystem Clock or User-Mounted Clock) .....	32
3-12	Crystal Oscillator (When Using Subsystem Clock or User-Mounted Clock) .....	34
3-13	Pin Alignment of Crystal Oscillator and Socket .....	34
3-14	External Trigger Input Position.....	37
4-1	Equivalent Circuit 1 of Emulation Circuit .....	41
4-2	Equivalent Circuit 2 of Emulation Circuit .....	42
4-3	Equivalent Circuit 3 of Emulation Circuit .....	43
4-4	Equivalent Circuit 4 of Emulation Circuit .....	43
4-5	Equivalent Circuit 5 of Emulation Circuit .....	44
4-6	Equivalent Circuit 6 of Emulation Circuit .....	44



## LIST OF TABLES

Table No.	Title	Page
1-1	Basic Specifications.....	15
1-2	Settings When Integrated Debugger Is Started .....	16
1-3	Value After Reset of EBTS .....	16
3-1	Main System Clock Settings .....	26
3-2	Subsystem Clock Settings.....	31
3-3	Jumper Settings on IE-78K0-NS .....	38
A-1	NP-42CU Pin Assignments .....	45
A-2	NP-44GB Pin Assignments .....	46
A-3	NP-100GC Pin Assignments .....	47
A-4	NP-100GF Pin Assignments.....	49

[MEMO]

## CHAPTER 1 GENERAL

The IE-78078-NS-EM1 is a development tool for efficient debugging of hardware or software when using one of the following target devices that belong to the 78K/0 Series of 8-bit single-chip microcontrollers.

This chapter describes the IE-78078-NS-EM1's system configuration and basic specifications.

- Target device
  - $\mu$ PD78075B Subseries
  - $\mu$ PD78078 Subseries
  - $\mu$ PD78078Y Subseries
  - $\mu$ PD78083 Subseries
  - $\mu$ PD78070A
  - $\mu$ PD78070AY

## 1.1 System Configuration

Figure 1-1 illustrates the IE-78078-NS-EM1's system configuration.

**Figure 1-1. System Configuration**

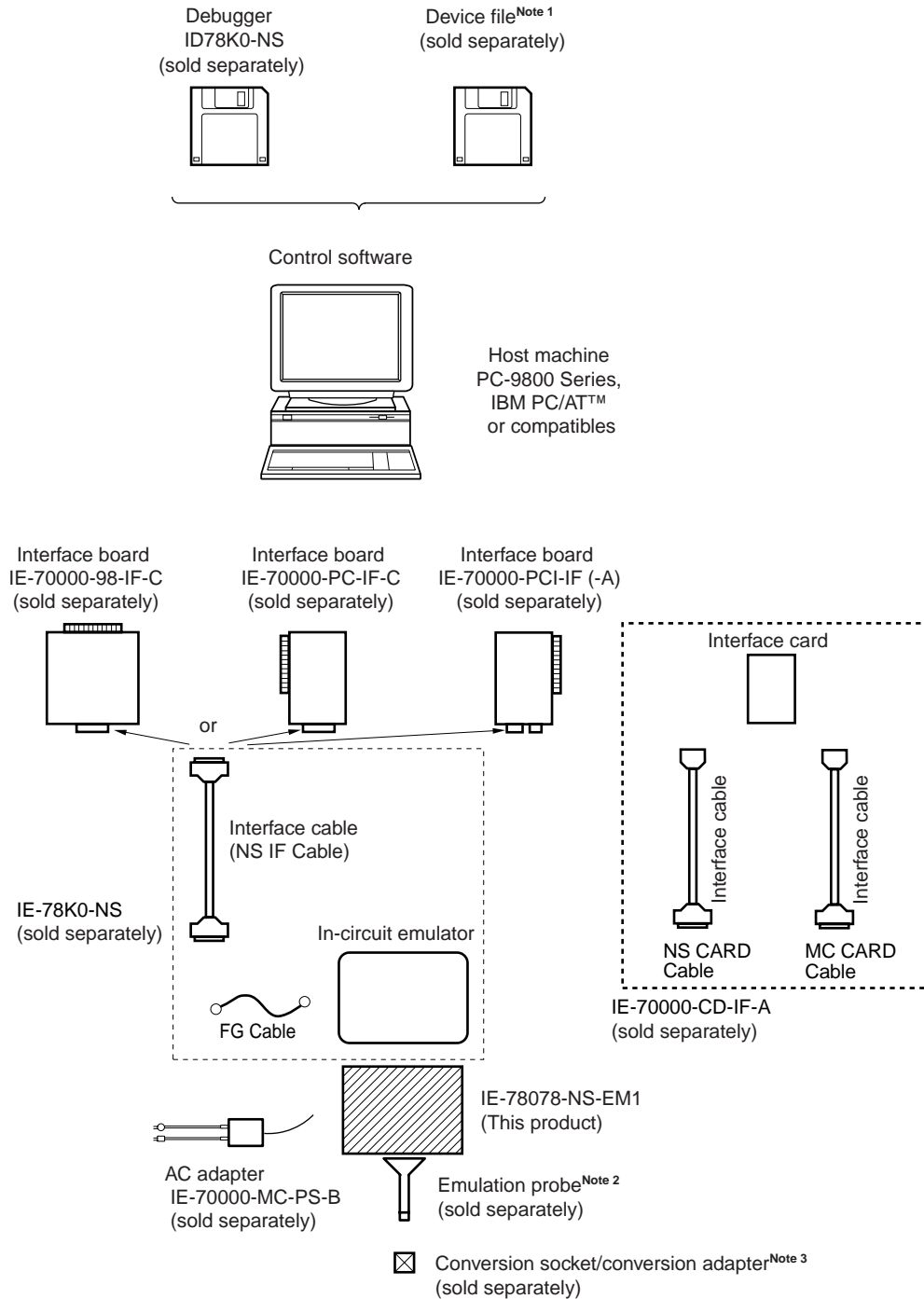

**Notes** 1. The device file is as follows, in accordance with the subseries.

$\mu$ SxxxxDF78078:  $\mu$ PD78075B, 78078, 78078Y Subseries, 78070A, 78070AY

$\mu$ SxxxxDF78083:  $\mu$ PD78083 Subseries

2. The emulation probe is as follows, in accordance with the package.

NP-42CU: 42-pin plastic SDIP (CU type)

NP-44GB: 44-pin plastic QFP (GB type)

NP-100GC: 100-pin plastic QFP (GC type)

NP-100GF: 100-pin plastic QFP (GF type)

The NP-42CU, NP-44GB, NP-100GC, and NP-100GF are products of Naito Densei Machida Mfg. Co., Ltd.

For further information, contact Naito Densei Machida Mfg. Co., Ltd. (TEL: +81-44-822-3813)

3. The conversion socket/conversion adapter are as follows, in accordance with the package.

EV-9200G-44: 44-pin plastic QFP (GB type)

EV-9200GF-100: 100-pin plastic QFP (GF type)

TGC-100SDW: 100-pin plastic QFP (GC type)

The TGC-100SDW is a product of TOKYO ELETECH CORPORATION.

For further information, contact Daimaru Kogyo Co., Ltd.

Tokyo Electronics Department (TEL: +81-3-3820-7112)

Osaka Electronics Department (TEL: +81-6-6244-6672)

## 1.2 Hardware Configuration

Figure 1-2 shows the IE-78078-NS-EM1's position in the basic hardware configuration.

**Figure 1-2. Basic Hardware Configuration**

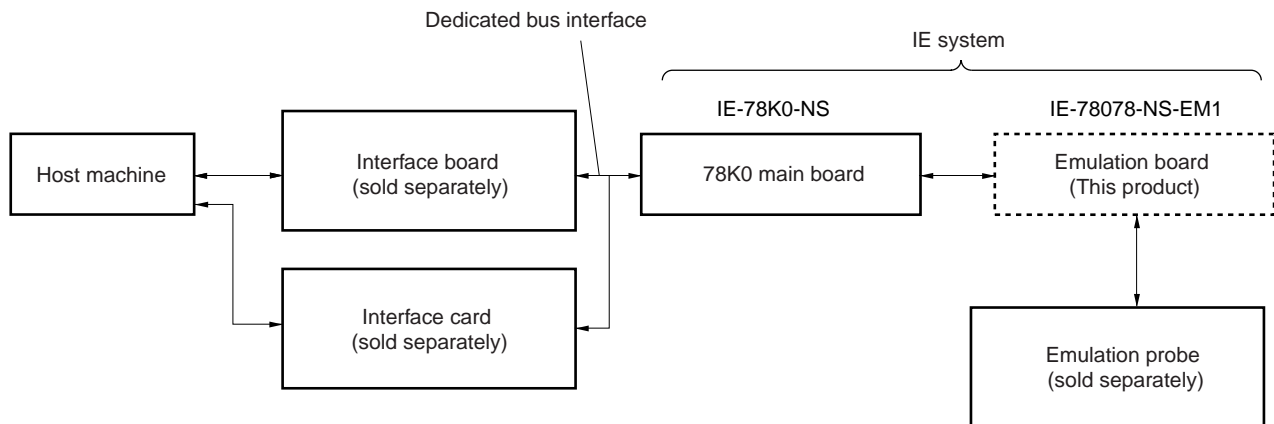

### 1.3 Basic Specifications

The IE-78078-NS-EM1's basic specifications are listed in Table 1-1.

**Table 1-1. Basic Specifications**

Parameter	Description
Target device	$\mu$ PD78075B, 78078, 78078Y, 78083 Subseries, $\mu$ PD78070A, $\mu$ PD78070AY
System clock	Main system clock: 5 MHz Subsystem clock: 32.768 kHz
Clock supply	External: Input via an emulation probe from the target system Internal: Mounted on the emulation board or mounted on the board by the user
Low voltage support	2 V or higher (same as target device)

## 1.4 Cautions on $\mu$ PD78070A and 78070AY Development

Since the IE-78078-NS-EM1 is designed for on-chip ROM products, the  $\mu$ PD78075B, 78078, 78078Y, 78083 Subseries, the following cautions are required when emulating ROM-less products, the  $\mu$ PD78070A and 78070AY.

- (1) When starting the integrated debugger, set as follows.

**Table 1-2. Settings When Integrated Debugger Is Started**

Item	When Emulating $\mu$ PD78070A	When Emulating $\mu$ PD78070AY
CPU series	78078	78078Y
Internal ROM size (KB) in mapping setting area of configuration dialog box	0	
Internal RAM size (bytes) in mapping setting area of configuration dialog box	1024	

Also, set the target memory in the mapping setting area of the configuration dialog box. A setting example is shown below.

**Example 1.** When external ROM (32 KB) is used for the target system

Target            0000, 7FFF

**Example 2.** When the internal memory of the IE-78K0-NS is used as virtual ROM (32 KB) (when target system is not used)

Emulation ROM   0000, 7FFF

- (2) During execution of the integrated debugger reset command, only pins A0 to A7 of the dedicated pins for accessing external ROM (AD0 to AD7,  $\overline{A0}$  to  $\overline{A15}$ ,  $\overline{RD}$ , and  $\overline{WR}$ ) are set to port mode. This is because in the IE-78078-NS-EM1, the value of the external bus type selection register (EBTS) becomes 00H after reset (the value becomes 0H1 for the actual  $\mu$ PD78070A and 78070AY).

**Table 1-3. Value After Reset of EBTS**

Item	When Emulating $\mu$ PD78070A	When Emulating $\mu$ PD78070AY
Value after EBTS reset	01H (separate bus mode)	00H (multiplexed bus mode)

Be sure to set EBTS to 01H prior to program execution, using the procedure shown below.



- <1> Execute CPU reset.
- <2> Change the value of EBTS in the SFR window from 00H to 01H.
- <3> Execute the program via the run panel.

Note that the value of EBTS becomes 00H by the reset performed by watchdog timer mode 2 of the watchdog timer (reset is triggered when an overflow occurs) and by the target system (the reset signal is input to  $\overline{\text{RESET}}$ ), therefore these operations cannot be emulated.

- (3) The following special function registers not included in the  $\mu\text{PD78070A}$  and  $78070\text{AY}$  are displayed, but these registers should be ignored.

P4, P5, P8, PM5, PM8, and KRM

**[MEMO]**

## CHAPTER 2 PART NAMES

This chapter introduces the parts of the IE-78078-NS-EM1 main unit.

The packing box contains the emulation board (IE-78078-NS-EM1), packing list, user's manual, and guarantee card.

If there are any missing or damaged items, please contact an NEC sales representative.

Fill out and return the guarantee card that comes with the main unit.

2.1 Parts of Main Unit

Figure 2-1. IE-78078-NS-EM1 Part Names

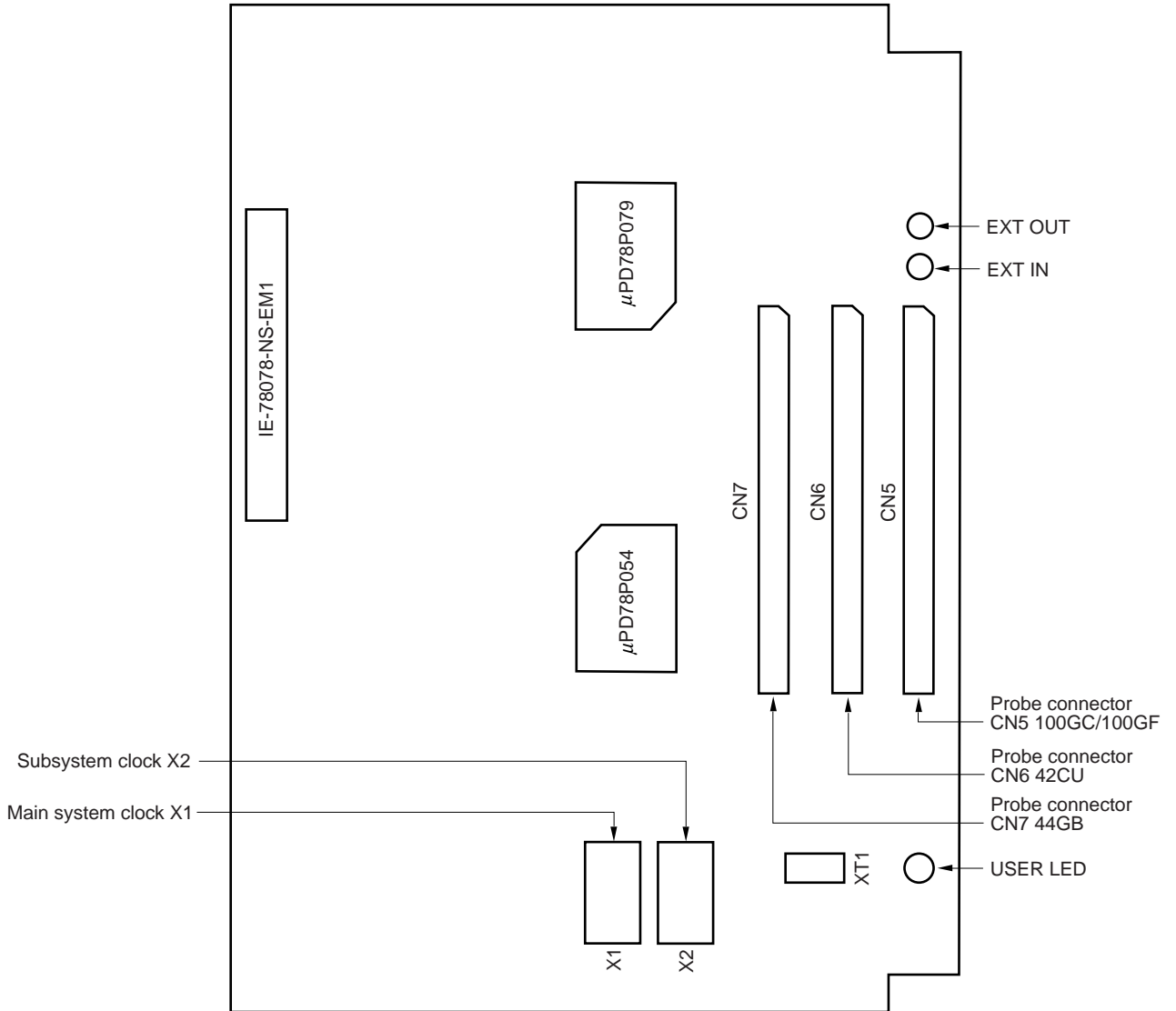

## CHAPTER 3 INSTALLATION

This chapter describes the methods for connecting the IE-78078-NS-EM1 to the IE-78K0-NS, emulation probe, etc. The mode setting methods are also described.

**Caution** Connecting or removing components to or from the target system, or making switch or other setting changes must be carried out after the power supply to both the IE system and the target system has been switched OFF.

### 3.1 Connection

#### (1) Connection with IE-78K0-NS main unit

See the **IE-78K0-NS User's Manual (U13731E)** for a description of how to connect the IE-78078-NS-EM1 to the IE-78K0-NS.

#### (2) Connection with emulation probe

See the **IE-78K0-NS User's Manual (U13731E)** for a description of how to connect an emulation probe to the IE-78078-NS-EM1.

On this board, connection to the emulation probe differs depending on the probe used.

When emulation probe NP-44GB is used, connect to CN7.

When emulation probe NP-42CU is used, connect to CN6.

When emulation probe NP-100GC or NP-100GF is used, connect to CN5.

**Caution** Incorrect connection may damage the IE system.  
Be sure to read the emulation probe's user's manual for a detailed description of the connection method.

Figure 3-1. Connection of Emulation Probe

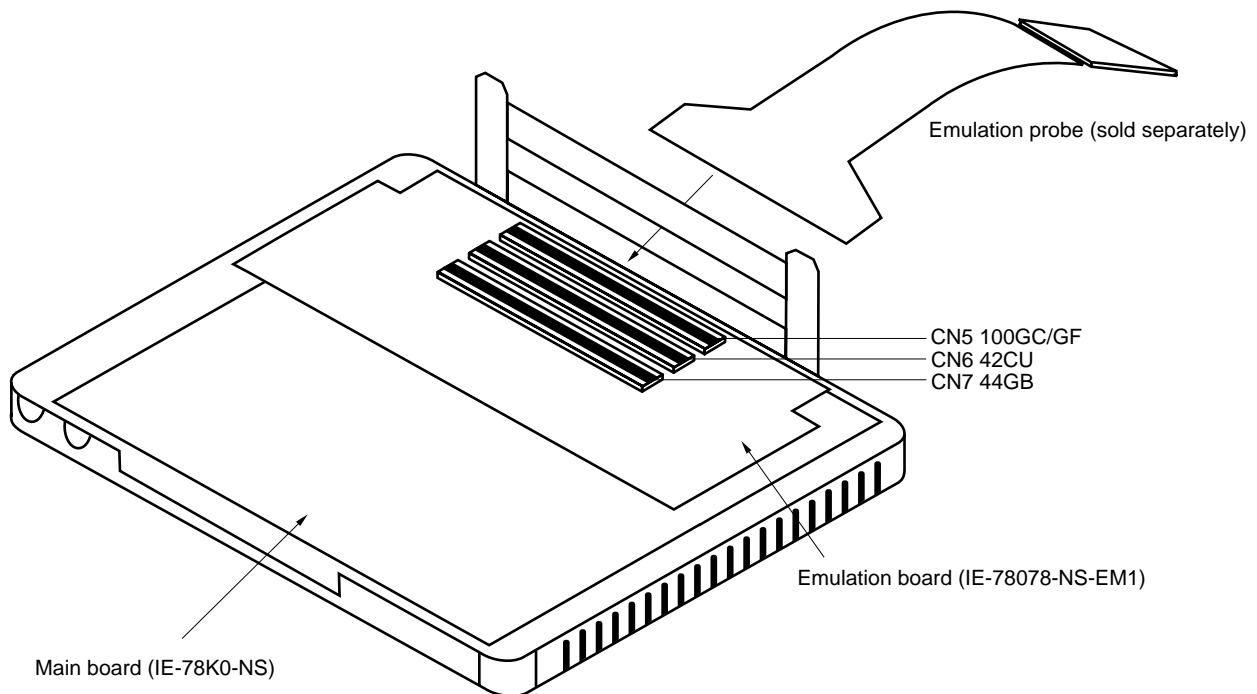

## 3.2 Clock Settings

### 3.2.1 Overview of clock settings

The main system and subsystem clocks to be used during debugging can be selected from (1) to (3) below.

- (1) Clock that is already mounted on emulation board
- (2) Clock that is mounted by user
- (3) External clock

If the target system includes an internal clock, select either “(1) Clock that is already mounted on emulation board” or “(2) Clock that is mounted by user”. For an internal clock, a resonator is connected to the target device and the target device’s internal oscillator is used. An example of the external circuit is shown in part (a) of Figure 3-2. During emulation, the resonator that is mounted on the target system is not used. Instead, the clock that is mounted on the emulation board installed for the IE-78K0-NS is used.

If the target system includes an external clock, select “(3) External clock”.

For an external clock, a clock signal is supplied from outside the target device and the target device’s internal oscillator is not used. An example of the external circuit is shown in part (b) of Figure 3-2.

**Caution** The IE system will be hung-up if the main system clock is not supplied normally. Moreover, be sure to input a rectangular wave as the clock from the target. The IE system does not operate if the crystal resonator is connected to X1 (main system clock) and XT1 (subsystem clock).

Figure 3-2. External Circuits Used as System Clock Oscillator

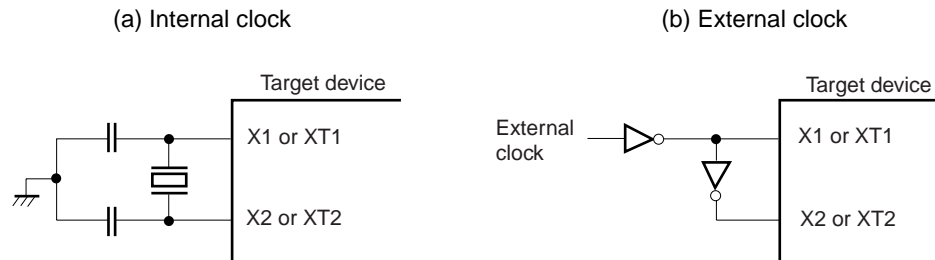

**(1) Clock that is already mounted on emulation board****(a) For main system clock**

A crystal oscillator (X1) is already mounted on the emulation board. Its frequency is 5.0 MHz.

**Figure 3-3. When Using Clock That Is Already Mounted on Emulation Board (Main System Clock)**

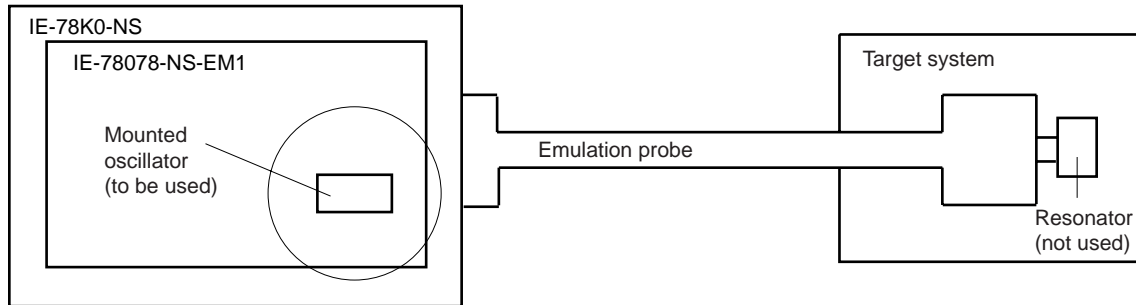

**Remark** The clock that is supplied by the IE-78078-NS-EM1's oscillator (encircled in the figure) is used.

**(b) For subsystem clock**

A crystal resonator (XT1) is already mounted on the emulation board. Its frequency is 32.768 kHz.

**Figure 3-4. When Using Clock That Is Already Mounted on Emulation Board (Subsystem Clock)**

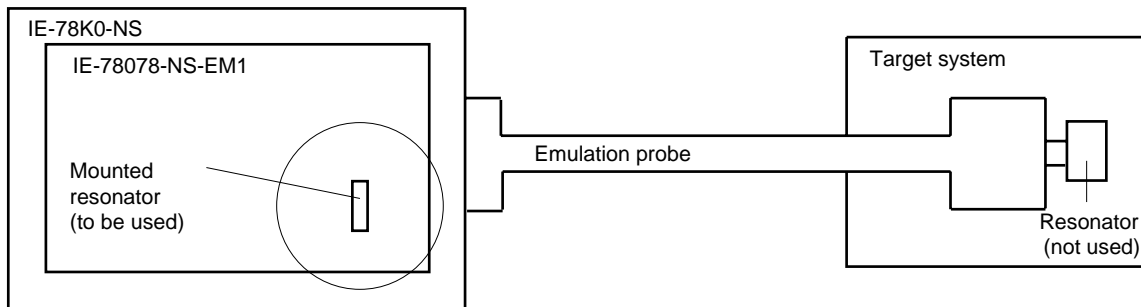

**Remark** The clock that is supplied by the IE-78078-NS-EM1's resonator (encircled in the figure) is used.



**(2) Clock that is mounted by user**

The user is able to mount any clock supported by the set specifications on the IE-78078-NS-EM1.

**(a) For main system clock**

Remove the crystal oscillator (X1) that is already mounted on the emulation board, and mount either the parts board on which the resonator to be used is mounted or an oscillator. This method is useful when using a different frequency from that of the pre-mounted clock.

**Figure 3-5. When Using User-Mounted Clock (Main System Clock)**

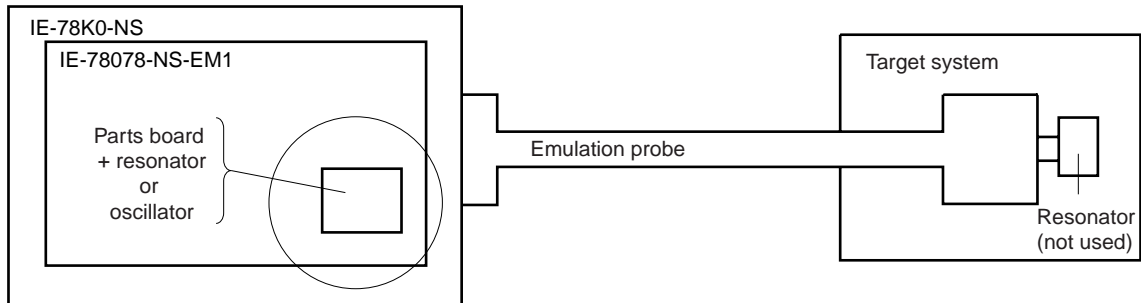

**Remark** The clock that is supplied by the IE-78078-NS-EM1's resonator or oscillator (encircled in the figure) is used.

**(b) For subsystem clock**

Mount the resonator to be used on the parts board (X2) that is already mounted on the emulation board. Alternatively, remove the parts board and mount an oscillator.

**Figure 3-6. When Using User-Mounted Clock (Subsystem Clock)**

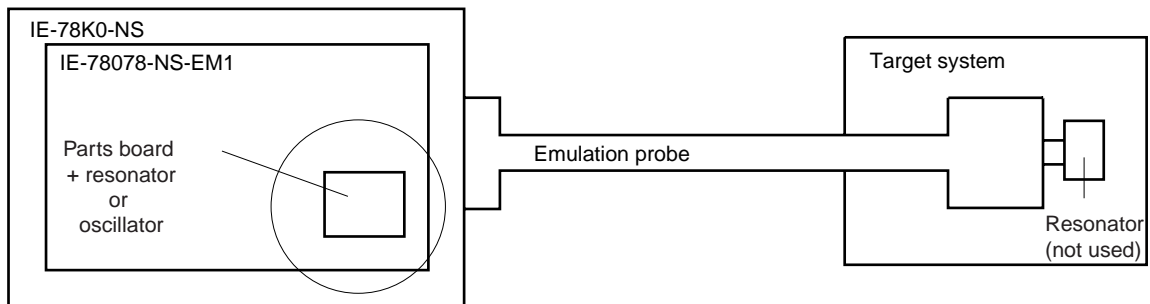

**Remark** The clock that is supplied by the IE-78078-NS-EM1's resonator or oscillator (encircled in the figure) is used.

**(3) External clock**

An external clock connected to the target system can be used via an emulation probe.

**Figure 3-7. When Using External Clock**

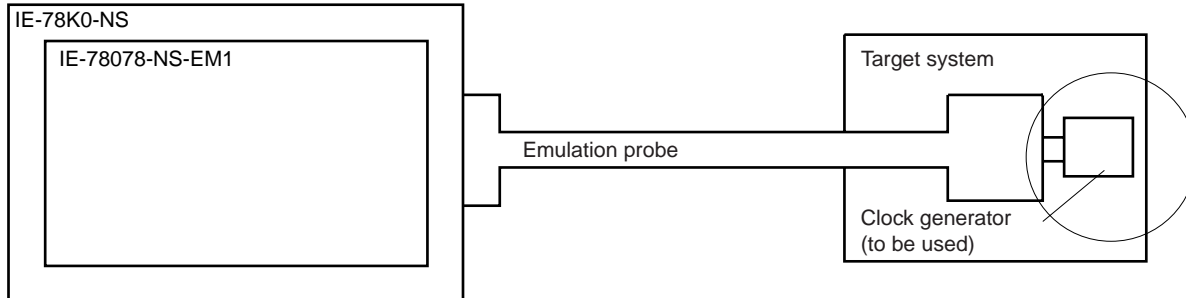

**Remark** The clock supplied by the target system's clock generator (encircled in the figure) is used.

**3.2.2 Main system clock settings**

**Table 3-1. Main System Clock Settings**

Frequency of Main System Clock		IE-78078-NS-EM1	CPU Clock Source Selection (ID)
		X1 Socket	
When using clock that is already mounted on emulation board	5.0 MHz	Oscillator used	Internal
When using clock mounted by user	Other than 5.0 MHz	Oscillator assembled by user	
When using external clock			Oscillator (not used)

**Caution** When using an external clock, open the configuration dialog box when starting the integrated debugger (ID78K0-NS) and select “External” in the area (Clock) for selecting the CPU’s clock source (this selects the user’s clock).

**Remark** When the IE-78078-NS-EM1 is shipped, the settings for “when using clock that is already mounted on emulation board” are preset.

**(1) When using clock that is already mounted on emulation board**

When the IE-78078-NS-EM1 is shipped, a 5.0 MHz crystal oscillator is already mounted in the IE-78078-NS-EM1’s X1 socket. When using the factory-set mode settings, there is no need to make any other hardware settings.

When starting the integrated debugger (ID78K0-NS), open the configuration dialog box and select “Internal” in the area (Clock) for selecting the CPU’s clock source (this selects the emulator’s internal clock).

**(2) When using clock mounted by user**

The settings described under either (a) or (b) are required, depending on the type of clock to be used. When starting the integrated debugger (ID78K0-NS), open the configuration dialog box and select "Internal" in the area (Clock) for selecting the CPU's clock source (this selects the emulator's internal clock).

**(a) When using a ceramic resonator or crystal resonator**

- Items to be prepared
  - Parts board (supplied with IE-78K0-NS)
  - Ceramic resonator or crystal resonator
  - Resistor Rx
- Capacitor CA
- Capacitor CB
- Solder kit

<Steps>

- <1> Solder the target ceramic resonator or crystal resonator, resistor Rx, capacitor CA, and capacitor CB (all with suitable oscillation frequency) onto the supplied parts board (as shown below).

**Figure 3-8. Connections on Parts Board (When Using Main System Clock or User-Mounted Clock)**

Parts board (X1)

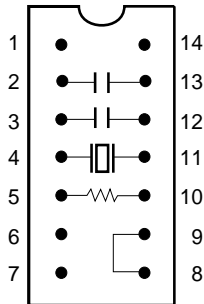

Pin No.	Connection
2-13	Capacitor CA
3-12	Capacitor CB
4-11	Ceramic resonator or crystal resonator
5-10	Resistor Rx
8-9	Short

Circuit diagram

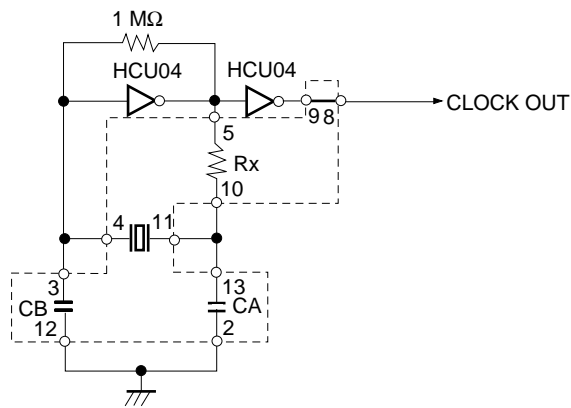

**Remark** The sections enclosed in broken lines indicate parts that are attached to the parts board.

- <2> Prepare the IE-78078-NS-EM1.
- <3> Remove the crystal oscillator that is mounted in the IE-78078-NS-EM1's X1 socket.
- <4> Connect the parts board (from <1> above) to the X1 socket from which the crystal oscillator was removed. Check the pin 1 mark to make sure the board is mounted in the correct direction.
- <5> Make sure that the parts board is wired as shown in Figure 3-8 above.
- <6> Install the IE-78078-NS-EM1 in the IE-78K0-NS.

The above steps configure the following circuit and enable supply of the clock from the mounted resonator to the emulation device.

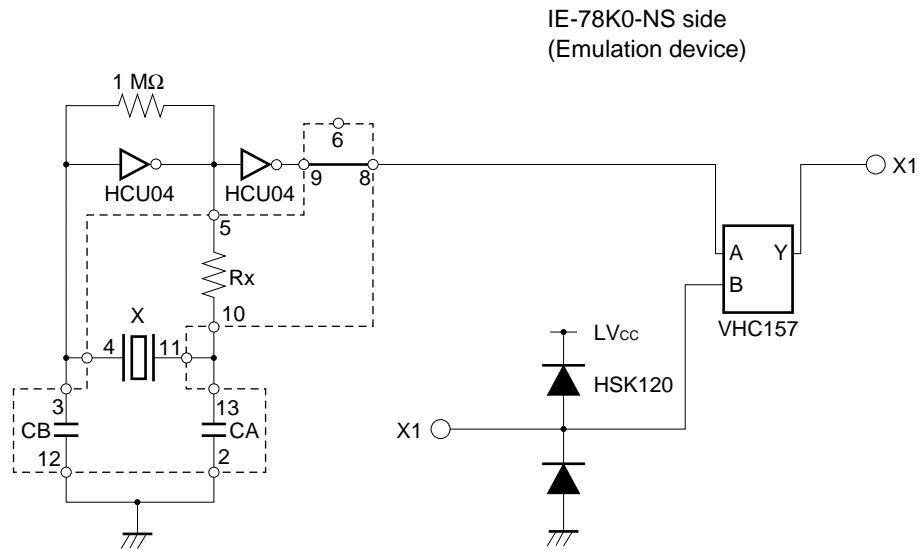

**Remark** The sections enclosed in broken lines indicate parts that are attached to the parts board.

(b) When using a crystal oscillator

- Items to be prepared
  - Crystal oscillator (see pinouts shown in Figure 3-9)

**Figure 3-9. Crystal Oscillator (When Using Main System Clock or User-Mounted Clock)**

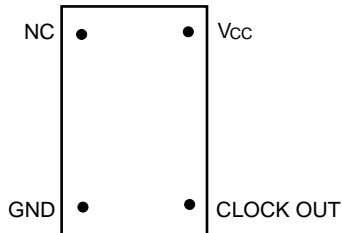

<Steps>

- <1> Prepare the IE-78078-NS-EM1.
- <2> Remove the crystal oscillator that is mounted in the IE-78078-NS-EM1's X1 socket.
- <3> Mount the crystal oscillator prepared by the user in the X1 socket from which the crystal oscillator was removed in <2> above. Insert the crystal oscillator pin into the socket aligning the pins as shown in the figure below.

**Figure 3-10. Pin Alignment of Crystal Oscillator and Socket**

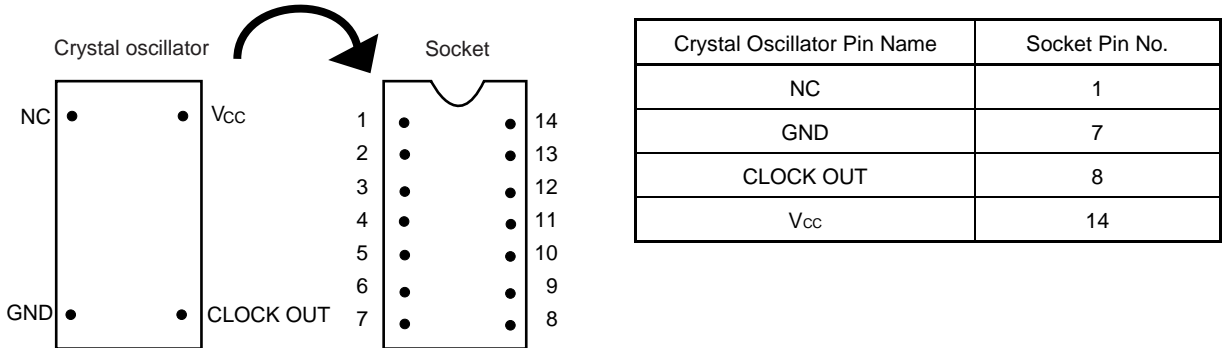

- <4> Install the IE-78078-NS-EM1 in the IE-78K0-NS.

The above steps configure the following circuit and enable supply of the clock from the mounted resonator to the emulation device.

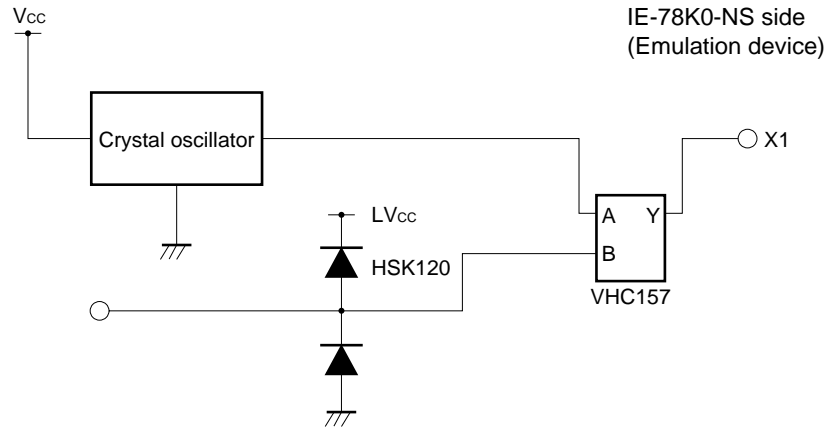

### (3) When using external clock

No hardware settings are required for this situation.

When starting the integrated debugger (ID78K0-NS), open the configuration dialog box and select "External" in the area (Clock) for selecting the CPU's clock source (this selects the user's clock).

## 3.2.3 Subsystem clock settings

Table 3-2. Subsystem Clock Settings

Frequency of Subsystem Clock to Be Used		IE-78078-NS-EM1	IE-78K0-NS
		X2 Socket	JP8
When using clock (XT1) that is already mounted on emulation board	32.768 kHz	6 and 8 shorted	Short 1 to 2 side
When using clock mounted by user	Other than 32.768 kHz	Oscillator assembled by user	
When using external clock		Not used	Short 3 to 4 side

**Caution** Jumper JP8, which is used to select the board's clock or an external clock, should be set only after turning off the IE-78K0-NS's power.

**Remark** When the IE-78078-NS-EM1 is shipped, the settings for "when using clock that is already mounted on emulation board" are preset.

**(1) When using clock that is already mounted on emulation board**

When the IE-78078-NS-EM1 is shipped, a 32.768 kHz crystal resonator (XT1) and the parts board (X2) on which pins 6 and 8 are shorted are already mounted on the IE-78078-NS-EM1. Short the 1 to 2 side on the IE-78K0-NS's jumper (JP8). There is no need to make any other settings via the integrated debugger (ID78K0-NS).

**(2) When using the clock mounted by user**

The settings described under either (a) or (b) are required, depending on the type of clock to be used. Short the 1 to 2 side on the IE-78K0-NS's jumper (JP8). For the jumper positions, refer to the **IE-78K0-NS User's Manual (U13731E)**.

There is no need to make any other settings via the integrated debugger (ID78K0-NS).

**(a) When using a ceramic resonator or crystal resonator**

- Items to be prepared
  - Parts board (included with IE-78K0-NS)
  - Ceramic resonator or crystal resonator
  - Resistor Rx
  - Capacitor CA
  - Capacitor CB
  - Solder kit

<Steps>

<1> Prepare the IE-78078-NS-EM1.

<2> Solder the ceramic resonator or crystal resonator, resistor Rx, capacitor CA, and capacitor CB (all with suitable oscillation frequency) onto the supplied parts board (X2) (as shown below).

Figure 3-11. Connections on Parts Board (When Using Subsystem Clock or User-Mounted Clock)

Parts board (X2)

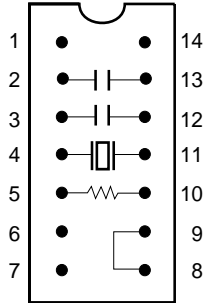

Pin No.	Connection
2-13	Capacitor CA
3-12	Capacitor CB
4-11	Ceramic resonator or crystal resonator
5-10	Resistor Rx
8-9	Short

Circuit diagram

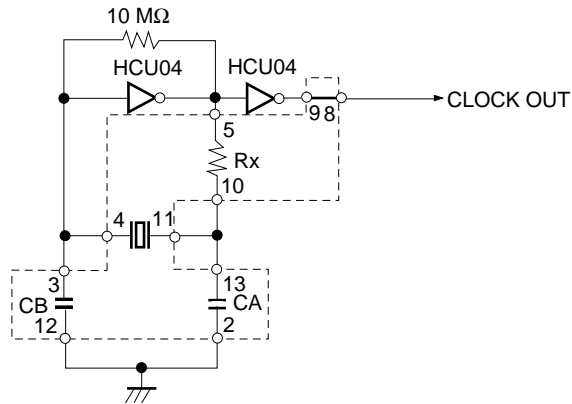

**Remark** The sections enclosed in broken lines indicate parts that are attached to the parts board.



- <3> Make sure that the parts board (X2) is wired as shown in Figure 3-11.
- <4> Remove the parts board that is mounted in the IE-78078-NS-EM1's X2 socket.
- <5> Mount the parts board of <2> above in the X2 socket from which the parts board was removed in <4>. Insert the parts board well, in the direction of the pin No.1 mark.
- <6> Install the IE-78078-NS-EM1 in the IE-78K0-NS.

The above steps configure the following circuit and enable supply of the clock from the mounted resonator to the emulation device.

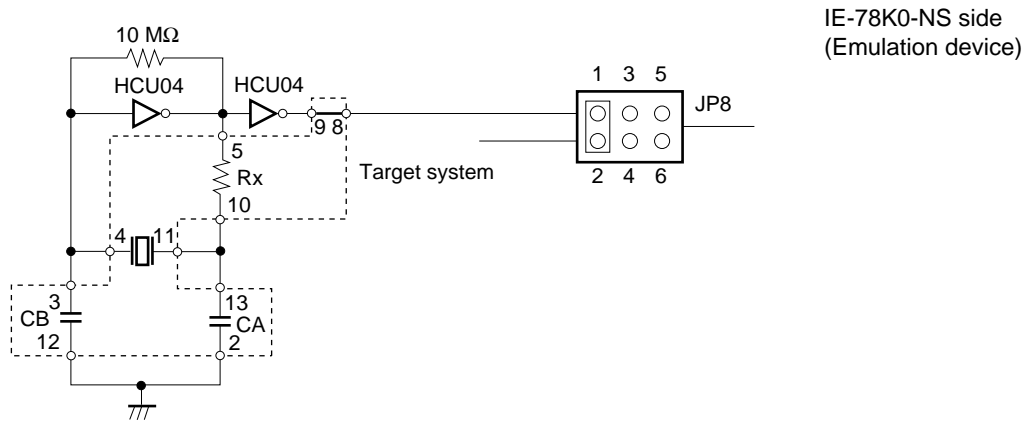

- Remarks**
- 1. The section enclosed in broken lines indicates parts that are attached to the parts board.
  - 2. JP8 is on the IE-78K0-NS.

**(b) When using a crystal oscillator**

- Items to be prepared
  - Crystal oscillator (see pinouts shown in Figure 3-12)

**Figure 3-12. Crystal Oscillator (When Using Subsystem Clock or User-Mounted Clock)**

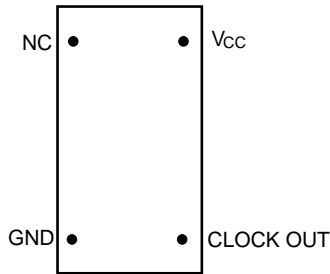

<Steps>

- <1> Prepare the IE-78078-NS-EM1.
- <2> Remove the parts board that is mounted in the IE-78078-NS-EM1's X2 socket.
- <3> Mount the crystal oscillator prepared by the user in the X2 socket from which the parts board was removed in <2> above. Insert the crystal oscillator pin into the socket aligning the pins as shown in the figure below.

**Figure 3-13. Pin Alignment of Crystal Oscillator and Socket**

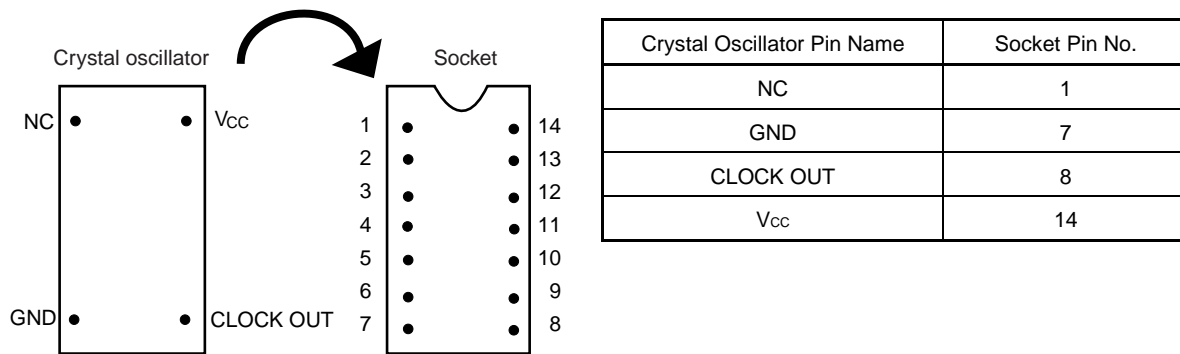

- <4> Install the IE-78078-NS-EM1 in the IE-78K0-NS.

The above steps configure the following circuit and enable supply of the clock from the mounted oscillator to the emulation device.

IE-78K0-NS side  
(Emulation device)

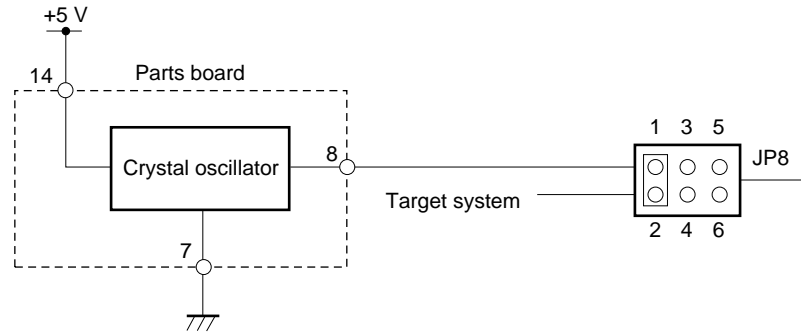

- Remarks**
1. The section enclosed in broken lines indicates parts that are attached to the parts board.
  2. JP8 is on the IE-78K0-NS.

**(3) When using an external clock**

Short the 3 to 4 side on the IE-78078-NS-EM1's jumper (JP8). There is no need to make any settings via the integrated debugger (ID78K0-NS).

### 3.3 Low-Voltage Emulation Setting

Low-voltage emulation is possible in the IE system.

In order to use the IE-78078-NS-EM1 at a low voltage, supply the same voltage as the target system from TP1 of the IE-78K0-NS.

- Maximum current consumption of TP1  
100 mA (1.8 V) to 300 mA (5 V)

### 3.4 External Trigger

To set up an external trigger, connect it to the IE-78078-NS-EM1's check pins EXTOUT and EXTIN as shown below.

Refer to the **ID78K0-NS User's Manual (U12900E)** for the usage method and the **IE-78K0-NS User's Manual (U13731E)** for the pin characteristics.

Figure 3-14. External Trigger Input Position

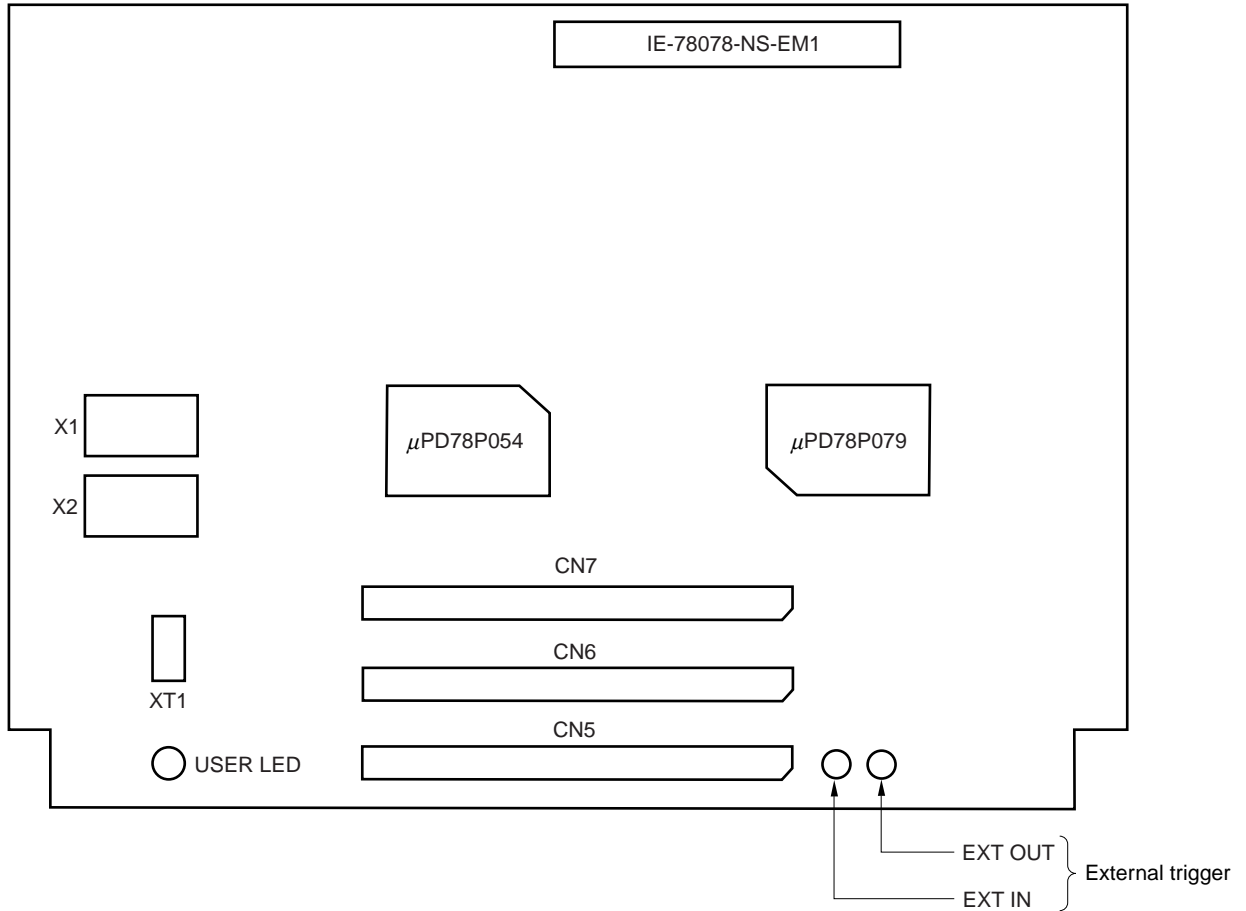

### 3.5 Jumper Settings

#### (1) Jumper settings on the IE-78K0-NS

When using the IE-78078-NS-EM1, set the jumpers on the IE-78K0-NS as shown in Table 3-3.

For details of these jumper settings, refer to the **IE-78K0-NS User's Manual (U13731E)**.

**Table 3-3. Jumper Settings on IE-78K0-NS**

	JP2	JP3	JP4	JP6	JP7	JP8
Shorted	2 to 3	1 to 2	1 to 2	3 to 4	5 to 6	1 to 2

## CHAPTER 4 DIFFERENCES BETWEEN TARGET DEVICES AND TARGET INTERFACE CIRCUITS

This chapter describes differences between the target device's signal lines and the signal lines of the IE-78078-NS-EM1's target interface circuit.

Although the target device is a CMOS circuit, the IE-78078-NS-EM1's target interface circuit consists of emulation circuits such as an emulation CPU, TTL, and CMOS-IC.

When the IE system is connected with the target system for debugging, the IE system performs emulation so as to operate as the actual target device would operate in the target system.

However, some minor differences exist since the operations are performed via the IE system's emulation.

- (1) Signals directly input/output to/from the emulation CPU  $\mu$ PD780009
- (2) Signals directly input/output to/from the emulation CPU  $\mu$ PD78P079
- (3) Signals directly input/output to/from the emulation CPU  $\mu$ PD78P054
- (4) Signals directly input/output to/from the emulation CPU  $\mu$ PD780009 and  $\mu$ PD78P079
- (5) Signals directly input/output to/from the emulation CPU  $\mu$ PD780009 and  $\mu$ PD78P054
- (6) Other signals

The IE system's circuit is used as follows for signals listed in (1) to (6) above.

**(1) Signals directly input/output to/from the emulation CPU  $\mu$ PD780009 (see Figure 4-1. Equivalent Circuit 1 of Emulation Circuit)**

- Signals related to port 5
- P63 to P60
- P67 to P65
- $\overline{\text{RESET}}$
- X1

**(2) Signals directly input/output to/from the emulation CPU  $\mu$ PD78P079 (see Figure 4-2. Equivalent Circuit 2 of Emulation Circuit)**

- Signals related to port 8
- P96 to P90
- P103 to P100

**(3) Signals directly input/output to/from the emulation CPU  $\mu$ PD78P054 (see Figure 4-3. Equivalent Circuit 3 of Emulation Circuit)**

- P06 to P00
- Signals related to port 1
- Signals related to port 2
- Signals related to port 3
- P72 to P70
- Signals related to port 12
- P131 and P130
- $AV_{DD}$ ,  $AV_{REF0}$ ,  $AV_{REF1}$ , and  $AV_{SS}$

**(4) Signals directly input/output to/from the emulation CPU  $\mu$ PD780009 and  $\mu$ PD78P079 (see Figure 4-4. Equivalent Circuit 4 of Emulation Circuit)**

- Signals related to port 4
- P64

**(5) Signals directly input/output to/from the emulation CPU  $\mu$ PD780009 and  $\mu$ PD78P054 (see Figure 4-5. Equivalent Circuit 5 of Emulation Circuit)**

- XT1

**(6) Other signals (see Figure 4-6. Equivalent Circuit 6 of Emulation Circuit)**

- $V_{DD}$ ,  $V_{SS}$ , XT2, X2, IC ( $V_{PP}$ )



Figure 4-1. Equivalent Circuit 1 of Emulation Circuit

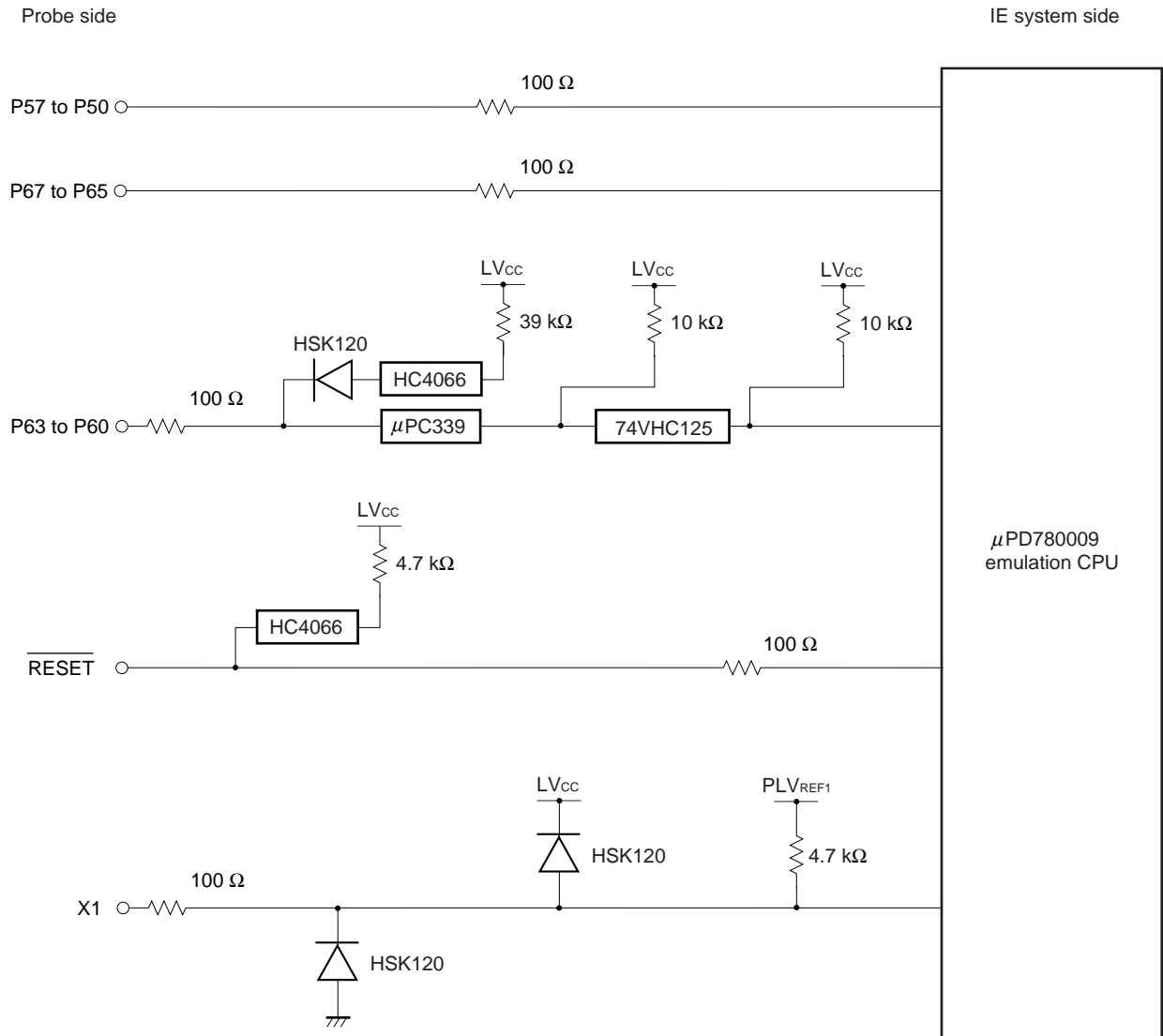

Figure 4-2. Equivalent Circuit 2 of Emulation Circuit

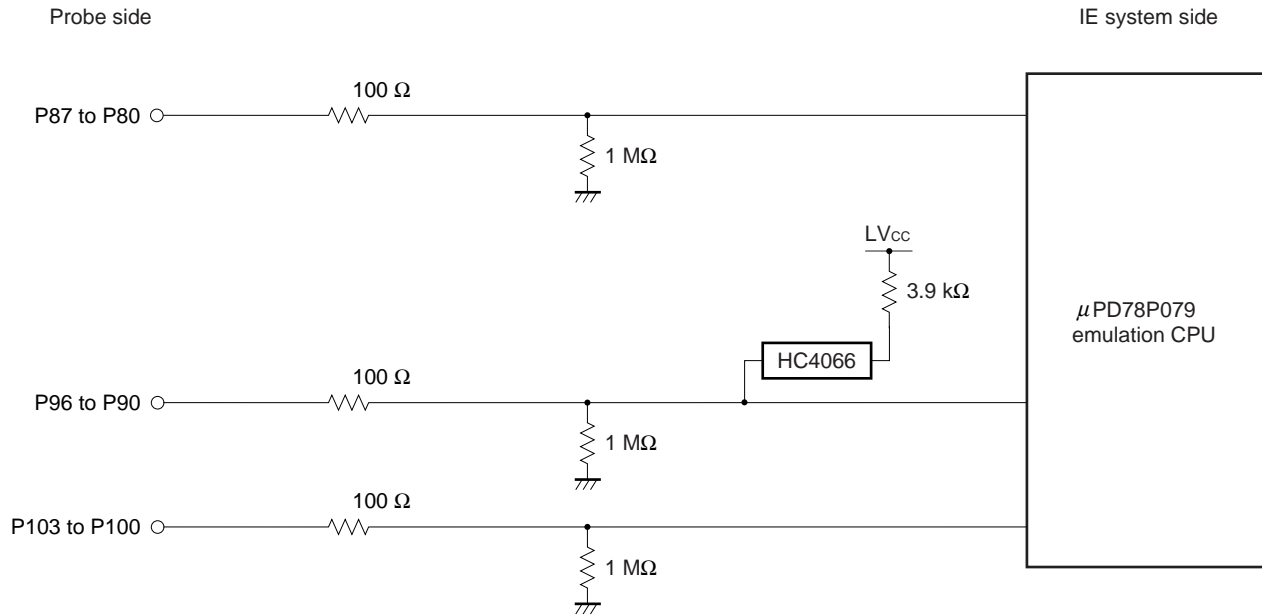

Figure 4-3. Equivalent Circuit 3 of Emulation Circuit

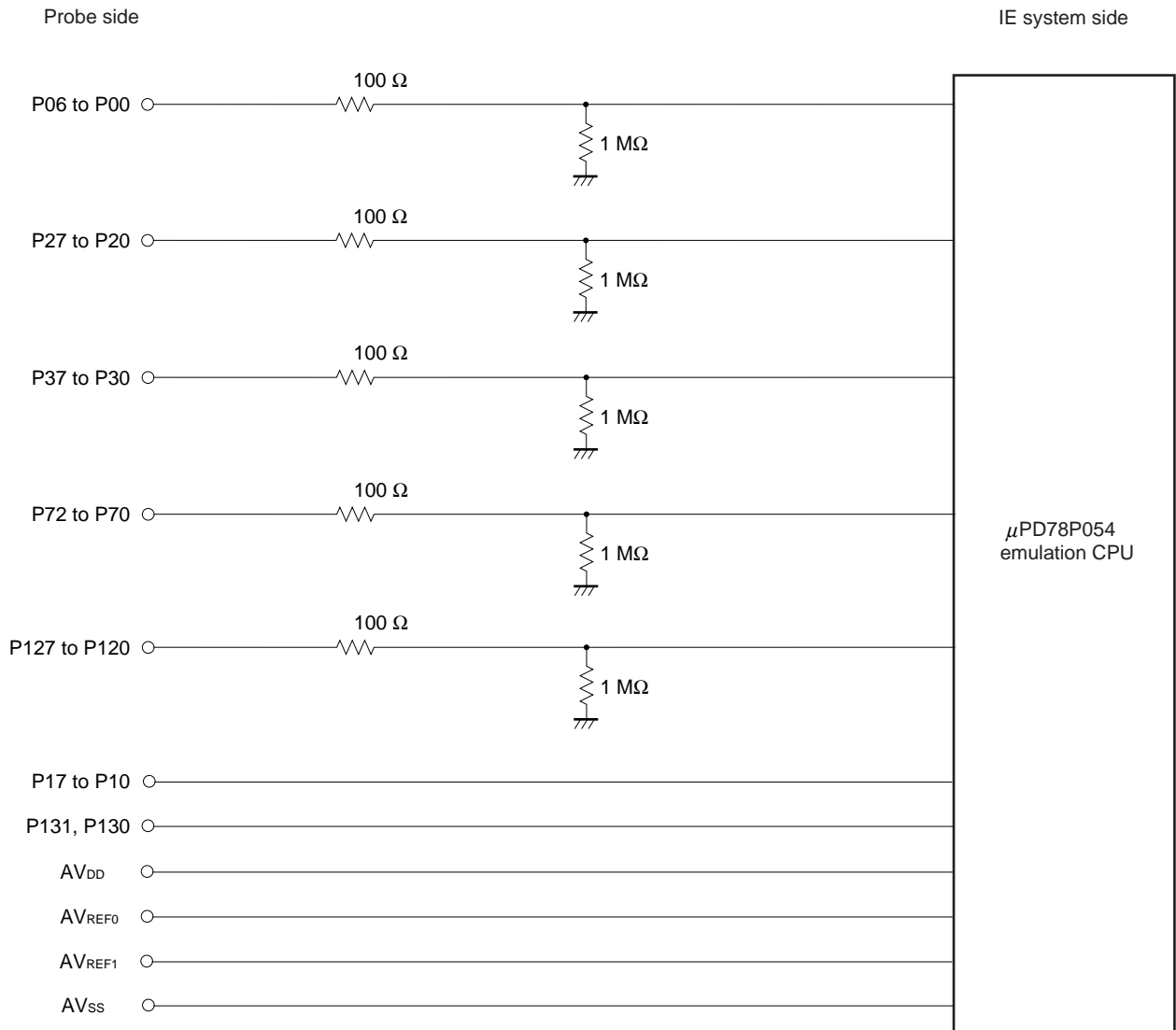

Figure 4-4. Equivalent Circuit 4 of Emulation Circuit

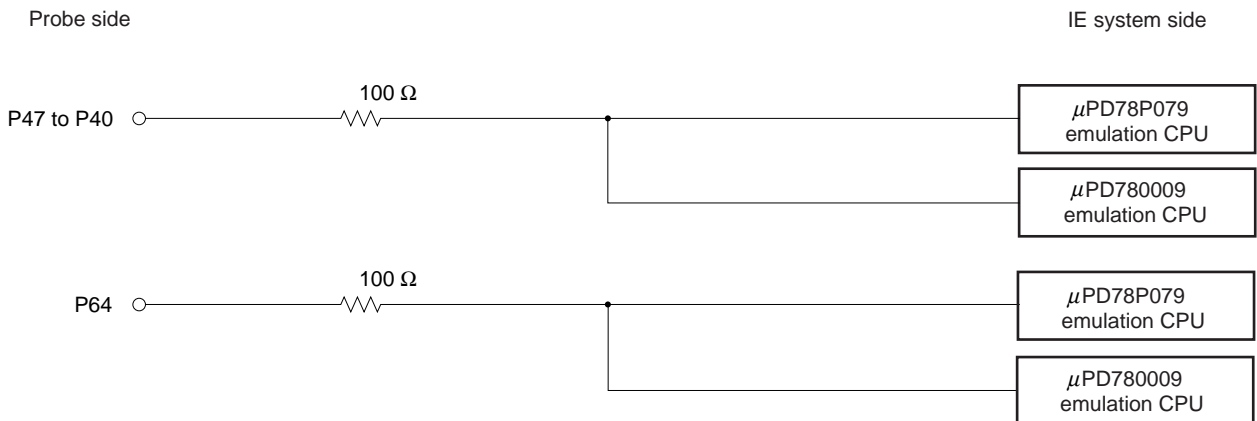

Figure 4-5. Equivalent Circuit 5 of Emulation Circuit

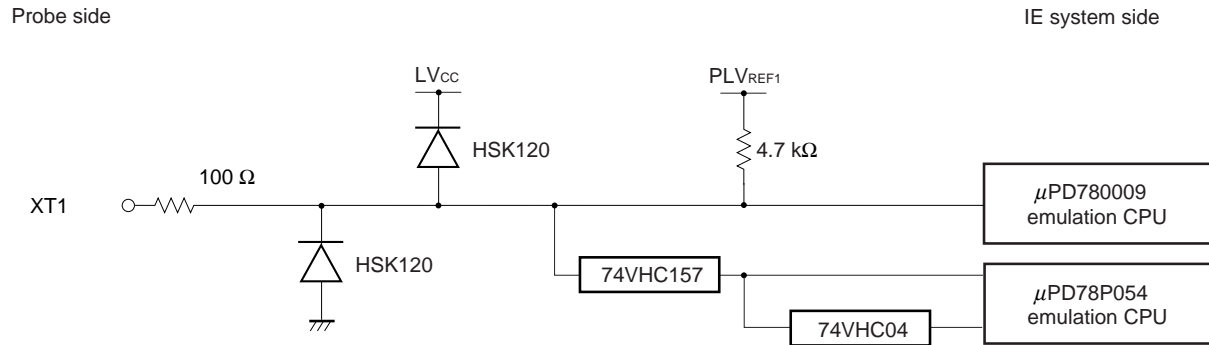
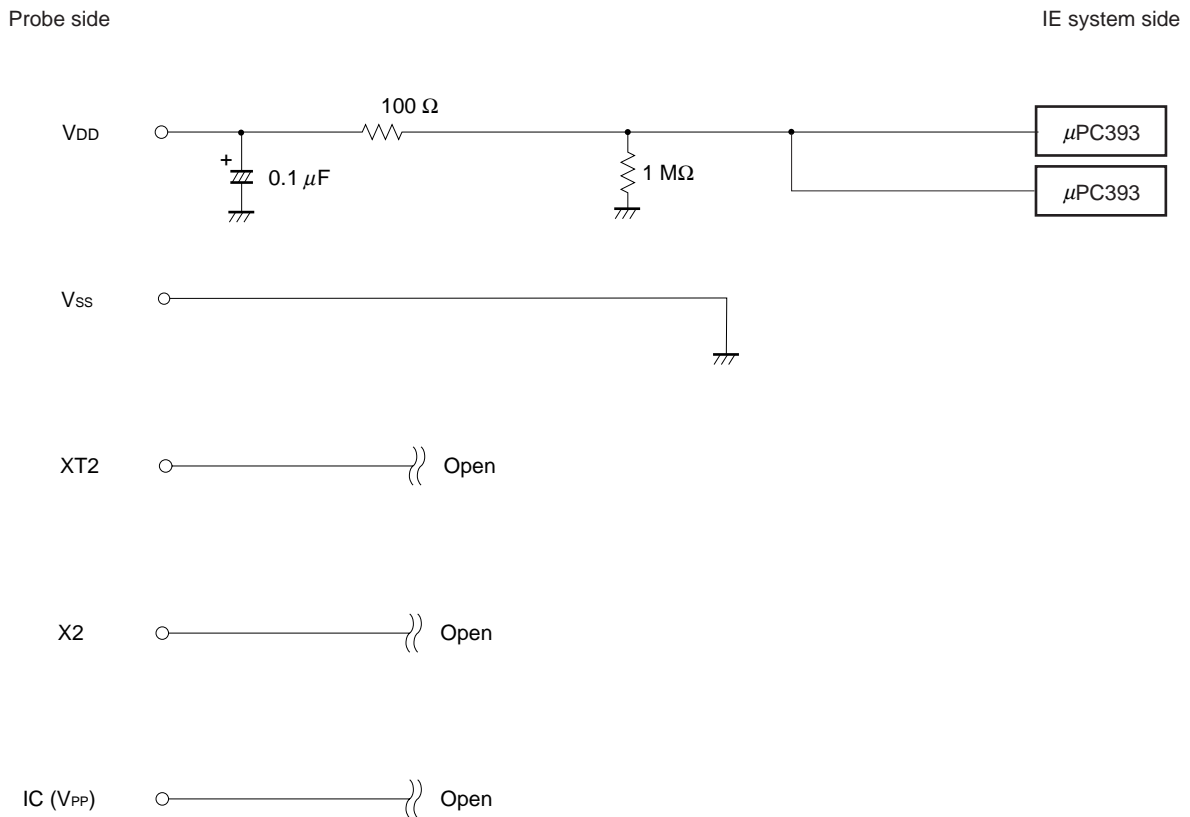

Figure 4-6. Equivalent Circuit 6 of Emulation Circuit



## APPENDIX EMULATION PROBE PIN ASSIGNMENT TABLE

**Table A-1. NP-42CU Pin Assignments**

Emulation Probe	CN6 Pin No.	Emulation Probe	CN6 Pin No.
1	59	22	61
2	60	23	62
3	55	24	65
4	56	25	66
5	49	26	71
6	18	27	104
7	17	28	103
8	22	29	100
9	21	30	99
10	28	31	94
11	27	32	93
12	92	33	30
13	91	34	29
14	98	35	24
15	97	36	23
16	102	37	20
17	72	38	48
18	69	39	51
19	70	40	52
20	63	41	57
21	64	42	58

- Remarks**
1. The NP-42CU is a product of Naito Densetsu Machida Mfg. Co., Ltd.
  2. The numbers in the “Emulation Probe” column indicate the corresponding pin number on the emulation probe tip.

Table A-2. NP-44GB Pin Assignments

Emulation Probe	CN7 Pin No.	Emulation Probe	CN7 Pin No.
1	104	23	18
2	103	24	17
3	100	25	22
4	99	26	21
5	94	27	28
6	93	28	27
7	30	29	92
8	29	30	91
9	24	31	98
10	23	32	97
11	20	33	102
12	47	34	73
13	48	35	72
14	51	36	69
15	52	37	70
16	57	38	63
17	58	39	64
18	59	40	61
19	60	41	62
20	55	42	65
21	56	43	66
22	49	44	71

**Remarks 1.** The NP-44GB is a product of Naito Densai Machida Mfg. Co., Ltd.

**2.** The numbers in the “Emulation Probe” column indicate the corresponding pin number on the emulation probe tip.

Table A-3. NP-100GC Pin Assignments (1/2)

Emulation Probe	CN5 Pin No.	Emulation Probe	CN5 Pin No.
1	118	33	51
2	117	34	52
3	114	35	57
4	113	36	58
5	108	37	59
6	107	38	60
7	104	39	55
8	103	40	56
9	100	41	49
10	99	42	50
11	94	43	45
12	93	44	46
13	30	45	41
14	29	46	42
15	24	47	35
16	23	48	36
17	20	49	31
18	19	50	32
19	16	51	4
20	15	52	3
21	10	53	8
22	9	54	7
23	6	55	14
24	5	56	3
25	33	57	18
26	34	58	17
27	37	59	22
28	38	60	21
29	43	61	28
30	44	62	27
31	47	63	92
32	48	64	91

**Remarks 1.** The NP-100GC is a product of Naito Densetsu Machida Mfg. Co., Ltd.

**2.** The numbers in the “Emulation Probe” column indicate the corresponding pin number on the emulation probe tip.

Table A-3. NP-100GC Pin Assignments (2/2)

Emulation Probe	CN5 Pin No.	Emulation Probe	CN5 Pin No.
65	98	83	69
66	97	84	70
67	102	85	63
68	101	86	64
69	106	87	61
70	105	88	62
71	112	89	65
72	111	90	66
73	116	91	71
74	115	92	72
75	87	93	75
76	88	94	76
77	83	95	79
78	84	96	80
79	77	97	85
80	78	98	86
81	73	99	89
82	74	100	90

**Remarks 1.** The NP-100GC is a product of Naito Densetsu Machida Mfg. Co., Ltd.

**2.** The numbers in the “Emulation Probe” column indicate the corresponding pin number on the emulation probe tip.



Table A-4. NP-100GF Pin Assignments (1/2)

Emulation Probe	CN5 Pin No.	Emulation Probe	CN5 Pin No.
1	116	33	108
2	115	34	107
3	87	35	104
4	88	36	103
5	83	37	100
6	84	38	99
7	77	39	94
8	78	40	93
9	73	41	30
10	74	42	29
11	69	43	24
12	70	44	23
13	63	45	20
14	64	46	19
15	61	47	16
16	62	48	15
17	65	49	10
18	66	50	9
19	71	51	6
20	72	52	5
21	75	53	33
22	76	54	34
23	79	55	37
24	80	56	38
25	85	57	43
26	86	58	44
27	89	59	47
28	90	60	48
29	118	61	51
30	117	62	52
31	114	63	57
32	113	64	58

**Remarks 1.** The NP-100GF is a product of Naito Densai Machida Mfg. Co., Ltd.

**2.** The numbers in the “Emulation Probe” column indicate the corresponding pin number on the emulation probe tip.

Table A-4. NP-100GF Pin Assignments (2/2)

Emulation Probe	CN5 Pin No.	Emulation Probe	CN5 Pin No.
65	59	83	14
66	60	84	13
67	55	85	18
68	56	86	17
69	49	87	22
70	50	88	21
71	45	89	28
72	46	90	27
73	41	91	92
74	42	92	91
75	35	93	98
76	36	94	97
77	31	95	102
78	32	96	101
79	4	97	106
80	3	98	105
81	8	99	112
82	7	100	111

**Remarks 1.** The NP-100GF is a product of Naito Densetsu Machida Mfg. Co., Ltd.

**2.** The numbers in the “Emulation Probe” column indicate the corresponding pin number on the emulation probe tip.

## Facsimile Message

Although NEC has taken all possible steps to ensure that the documentation supplied to our customers is complete, bug free and up-to-date, we readily accept that errors may occur. Despite all the care and precautions we've taken, you may encounter problems in the documentation. Please complete this form whenever you'd like to report errors or suggest improvements to us.

From:

Name

Company

Tel.

FAX

Address

*Thank you for your kind support.*

### North America

NEC Electronics Inc.  
Corporate Communications Dept.  
Fax: 1-800-729-9288  
1-408-588-6130

### Hong Kong, Philippines, Oceania

NEC Electronics Hong Kong Ltd.  
Fax: +852-2886-9022/9044

### Asian Nations except Philippines

NEC Electronics Singapore Pte. Ltd.  
Fax: +65-250-3583

### Europe

NEC Electronics (Europe) GmbH  
Technical Documentation Dept.  
Fax: +49-211-6503-274

### Korea

NEC Electronics Hong Kong Ltd.  
Seoul Branch  
Fax: 02-528-4411

### Japan

NEC Semiconductor Technical Hotline  
Fax: 044-435-9608

### South America

NEC do Brasil S.A.  
Fax: +55-11-6462-6829

### Taiwan

NEC Electronics Taiwan Ltd.  
Fax: 02-2719-5951

I would like to report the following error/make the following suggestion:

Document title: \_\_\_\_\_

Document number: \_\_\_\_\_ Page number: \_\_\_\_\_

If possible, please fax the referenced page or drawing.

Document Rating	Excellent	Good	Acceptable	Poor
Clarity	<input type="checkbox"/>	<input type="checkbox"/>	<input type="checkbox"/>	<input type="checkbox"/>
Technical Accuracy	<input type="checkbox"/>	<input type="checkbox"/>	<input type="checkbox"/>	<input type="checkbox"/>
Organization	<input type="checkbox"/>	<input type="checkbox"/>	<input type="checkbox"/>	<input type="checkbox"/>