

User's Manual**IE-78018-NS-EM1****Emulation Board**

Target device

μPD78002 Subseries	μPD78002Y Subseries
μPD78014 Subseries	μPD78014Y Subseries
μPD78014H Subseries	μPD78018F Subseries
μPD78018FY Subseries	μPD780001

[MEMO]

Windows is either a registered trademark or a trademark of Microsoft Corporation in the United States and/or other countries.

PC/AT is a trademark of International Business Machines Corporation.

The information in this document is subject to change without notice.

No part of this document may be copied or reproduced in any form or by any means without the prior written consent of NEC Corporation. NEC Corporation assumes no responsibility for any errors which may appear in this document.

NEC Corporation does not assume any liability for infringement of patents, copyrights or other intellectual property rights of third parties by or arising from use of a device described herein or any other liability arising from use of such device. No license, either express, implied or otherwise, is granted under any patents, copyrights or other intellectual property rights of NEC Corporation or of others.

Regional Information

Some information contained in this document may vary from country to country. Before using any NEC product in your application, please contact the NEC office in your country to obtain a list of authorized representatives and distributors. They will verify:

- Device availability
- Ordering information
- Product release schedule
- Availability of related technical literature
- Development environment specifications (for example, specifications for third-party tools and components, host computers, power plugs, AC supply voltages, and so forth)
- Network requirements

In addition, trademarks, registered trademarks, export restrictions, and other legal issues may also vary from country to country.

NEC Electronics Inc. (U.S.)

Santa Clara, California
Tel: 408-588-6000
800-366-9782
Fax: 408-588-6130
800-729-9288

NEC Electronics (Germany) GmbH

Duesseldorf, Germany
Tel: 0211-65 03 02
Fax: 0211-65 03 490

NEC Electronics (UK) Ltd.

Milton Keynes, UK
Tel: 01908-691-133
Fax: 01908-670-290

NEC Electronics Italiana s.r.l.

Milano, Italy
Tel: 02-66 75 41
Fax: 02-66 75 42 99

NEC Electronics (Germany) GmbH

Benelux Office
Eindhoven, The Netherlands
Tel: 040-2445845
Fax: 040-2444580

NEC Electronics (France) S.A.

Velizy-Villacoublay, France
Tel: 01-30-67 58 00
Fax: 01-30-67 58 99

NEC Electronics (France) S.A.

Spain Office
Madrid, Spain
Tel: 91-504-2787
Fax: 91-504-2860

NEC Electronics (Germany) GmbH

Scandinavia Office
Taeby, Sweden
Tel: 08-63 80 820
Fax: 08-63 80 388

NEC Electronics Hong Kong Ltd.

Hong Kong
Tel: 2886-9318
Fax: 2886-9022/9044

NEC Electronics Hong Kong Ltd.

Seoul Branch
Seoul, Korea
Tel: 02-528-0303
Fax: 02-528-4411

NEC Electronics Singapore Pte. Ltd.

United Square, Singapore 1130
Tel: 65-253-8311
Fax: 65-250-3583

NEC Electronics Taiwan Ltd.

Taipei, Taiwan
Tel: 02-2719-2377
Fax: 02-2719-5951

NEC do Brasil S.A.

Electron Devices Division
Rodovia Presidente Dutra, Km 214
07210-902-Guarulhos-SP Brasil
Tel: 55-11-6465-6810
Fax: 55-11-6465-6829

J99.1

INTRODUCTION

Product Overview

The IE-78018-NS-EM1 is designed to be used with the IE-78K0-NS to debug the following target devices that belong to the 78K/0 Series of 8-bit single-chip microcontrollers.

- μ PD78002 Subseries: μ PD78001B, 78002B, 78P014
- μ PD78002Y Subseries: μ PD78001BY, 78002BY, 78P014Y
- μ PD78014 Subseries: μ PD78011B, 78012B, 78013, 78014, 78P014
- μ PD78014Y Subseries: μ PD78011BY, 78012BY, 78013Y, 78014Y, 78P014Y
- μ PD78014H Subseries: μ PD78011H, 78012H, 78013H, 78014H, 78P018F
- μ PD78018F Subseries: μ PD78011F, 78012F, 78013F, 78014F, 78015F, 78016F, 78018F, 78P018F
- μ PD78018FY Subseries: μ PD78011FY, 78012FY, 78013FY, 78014FY, 78015FY, 78016FY, 78018FY, 78P018FY
- μ PD780001: μ PD780001

Target Readers

This manual is intended for engineers who will use the IE-78018-NS-EM1 with the IE-78K0-NS to perform system debugging.

Engineers who use this manual are expected to be thoroughly familiar with the target device's functions and use methods and to be knowledgeable about debugging.

Organization

When using the IE-78018-NS-EM1, refer to not only this manual (supplied with the IE-78018-NS-EM1) but also the manual that is supplied with the IE-78K0-NS.

IE-78K0-NS User's Manual

- Basic specifications
- System configuration
- External interface functions

IE-78018-NS-EM1 User's Manual

- General
- Part names
- Installation
- Differences between target devices and target interface circuits

Purpose

This manual's purpose is to explain various debugging functions that can be performed when using the IE-78018-NS-EM1.

Terminology

The meanings of certain terms used in this manual are listed below.

Term	Meaning
Emulation device	This is a general term that refers to the device in the emulator that is used to emulate the target device. It includes the emulation CPU.
Emulation CPU	This is the CPU block in the emulator that is used to execute user-generated programs.
Target device	This is the device (real chip) that is the target for emulation.
Target system	This includes the target program and the hardware provided by the user. When defined narrowly, it includes only the hardware.
IE system	This refers to the combination of the IE-78K0-NS and the IE-78018-NS-EM1.

Conventions

Data significance: Higher digits on the left and lower digits on the right

Note: Footnote for item marked with **Note** in the text

Caution: Information requiring particular attention

Remark: Supplementary information

Related Documents

The related documents (user's manuals) indicated in this publication may include preliminary versions. However, preliminary versions are not marked as such.

Document Name	Document Number	
	English	Japanese
IE-78K0-NS	To be prepared	U13731J
IE-78018-NS-EM1	This manual	U13289J
ID78K0-NS Integrated Debugger Reference Windows™ Based	U12900E	U12900J
μPD78002, 78002Y Subseries	U10039E	U10039J
μPD78014, 78014Y Subseries	U10085E	U10085J
μPD78014H Subseries	U12220E	U12220J
μPD78018F, 78018FY Subseries	U10659E	U10659J
μPD780001	U10885E	U10885J

Caution The documents listed above are subject to change without notice. Be sure to use the latest documents when designing.

CONTENTS

CHAPTER 1 GENERAL	11
1.1 System Configuration	12
1.2 Hardware Configuration	14
1.3 Basic Specifications	15
CHAPTER 2 PART NAMES	17
2.1 Parts of Main Unit	18
CHAPTER 3 INSTALLATION	19
3.1 Connection	20
3.2 Clock Settings	21
3.2.1 Overview of clock settings.....	21
3.2.2 Main system clock settings.....	23
3.2.3 Subsystem clock settings	28
3.3 External Trigger	33
3.4 Jumper Settings on IE-78K0-NS	34
CHAPTER 4 DIFFERENCES BETWEEN TARGET DEVICES AND TARGET INTERFACE CIRCUITS	35
APPENDIX EMULATION PROBE PIN ASSIGNMENT TABLE	39

LIST OF FIGURES

Figure No.	Title	Page
1-1.	System Configuration.....	12
1-2.	Basic Hardware Configuration	14
2-1.	IE-78018-NS-EM1 Part Names	18
3-1.	Connection of Emulation Probe.....	20
3-2.	External Circuits Used as System Clock Oscillation Circuit.....	21
3-3.	When Using Clock That Is Already Mounted on Emulation Board.....	22
3-4.	When Using User-Mounted Clock	22
3-5.	When Using an External Clock.....	23
3-6.	Connections on Parts Board (When Using Main System Clock or User-Mounted Clock)	24
3-7.	Crystal Oscillator (When Using Main System Clock or User-Mounted Clock).....	26
3-8.	Pin Alignment of Crystal Oscillator and Socket	26
3-9.	Connections on Parts Board (When Using Subsystem Clock or User-Mounted Clock)	29
3-10.	Crystal Oscillator (When Using Subsystem Clock or User-Mounted Clock)	31
3-11.	Pin Alignment of Crystal Oscillator and Socket	31
3-12.	External Trigger Input Position	33
4-1.	Equivalent Circuit 1 from Emulation Circuit.....	36
4-2.	Equivalent Circuit 2 from Emulation Circuit.....	37

LIST OF TABLES

Table No.	Title	Page
1-1.	Basic Specifications	15
3-1.	Main System Clock Settings.....	23
3-2.	Subsystem Clock Settings.....	28
3-3.	Jumper Settings on IE-78K0-NS	34
A-1.	NP-64GC/GK Pin Assignments.....	39
A-2.	NP-64CW Pin Assignments	40

[MEMO]

CHAPTER 1 GENERAL

The IE-78018-NS-EM1 is a development tool for efficient debugging of hardware or software when using one of the following target devices that belong to the 78K/0 Series of 8-bit single-chip microcontrollers.

This chapter describes the IE-78018-NS-EM1's system configuration and basic specifications.

- Target device
 - μ PD78002 Subseries
 - μ PD78002Y Subseries
 - μ PD78014 Subseries
 - μ PD78014Y Subseries
 - μ PD78014H Subseries
 - μ PD78018F Subseries
 - μ PD78018FY Subseries
 - μ PD780001

1.1 System Configuration

Figure 1-1 illustrates the IE-78018-NS-EM1's system configuration.

Figure 1-1. System Configuration

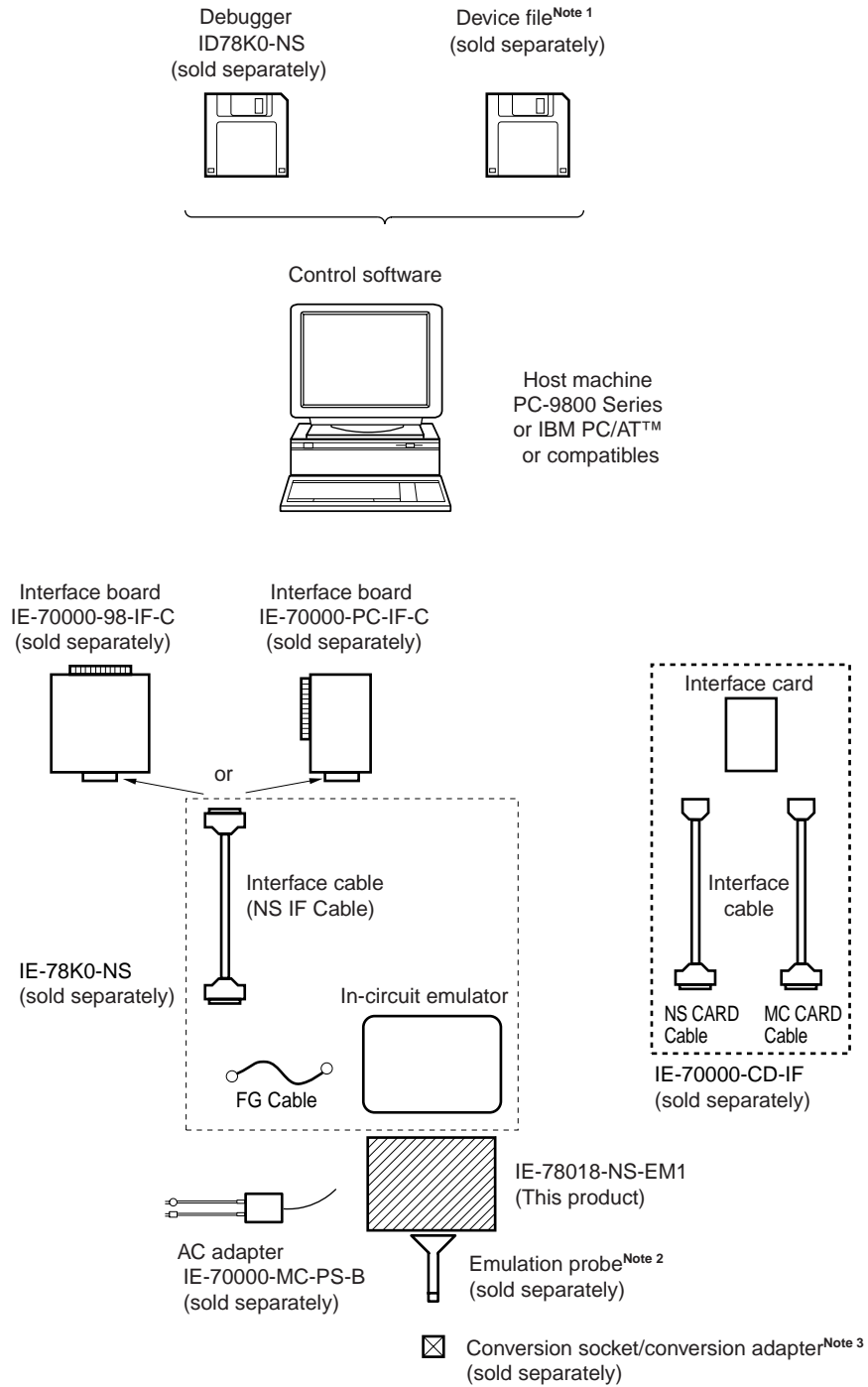

Notes 1. The device file is as follows, in accordance with the subseries.

μ SxxxxDF78002: μ PD78002, 78002Y Subseries

μ SxxxxDF78014: μ PD78014, 78014Y, 78014H, 78018F, 78018FY Subseries

μ SxxxxDF780001: μ PD780001

2. The emulation probe is as follows, in accordance with the package.

NP-64CW: 64-pin plastic shrink DIP (CW type)

NP-64GC: 64-pin plastic QFP (GC-AB8 type)

NP-64GK: 64-pin plastic LQFP (GK-8A8 type)

The NP-64CW, NP-64GC, and NP-64GK are products made by Naito Densei Machida Seisakusho Co., Ltd.

For further information, contact Naito Densei Machida Seisakusho Co., Ltd. (TEL: +81-44-822-3813)

3. The conversion socket/conversion adapter are as follows, in accordance with the package.

EV-9200GC-64: 64-pin plastic QFP (GC-AB8 type)

TGK-064SBW: 64-pin plastic LQFP (GK-8A8 type)

The TGK-064SBW is a product of TOKYO ELETECH CORPORATION.

For further information, contact Daimaru Kogyo Co., Ltd.

Tokyo Electronics Department (TEL: +81-3-3820-7112)

Osaka Electronics Department (TEL: +81-6-6244-6672)

1.2 Hardware Configuration

Figure 1-2 shows the IE-78018-NS-EM1's position in the basic hardware configuration.

Figure 1-2. Basic Hardware Configuration

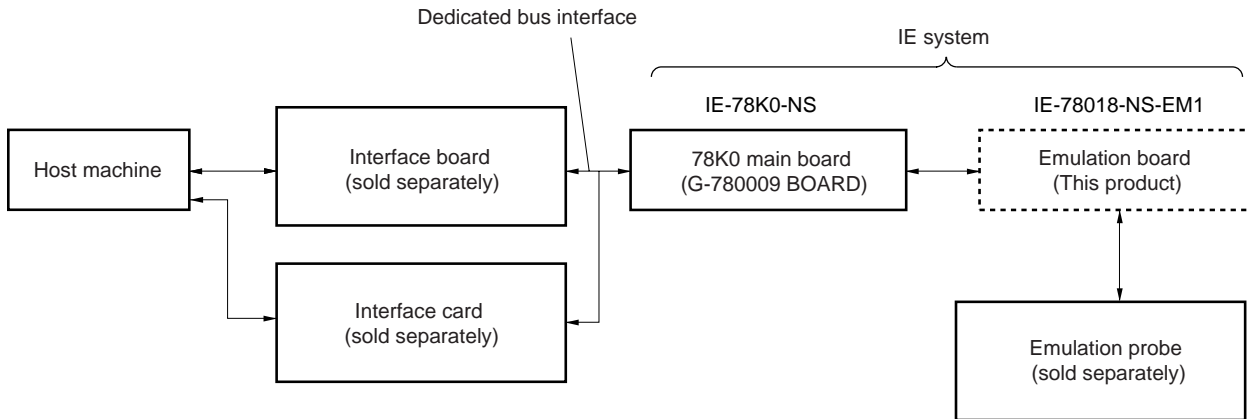

1.3 Basic Specifications

The IE-78018-NS-EM1's basic specifications are listed in Table 1-1.

Table 1-1. Basic Specifications

Parameter	Description
Target device	μ PD78002, 78002Y, 78014, 78014Y, 78014H, 78018F, 78018FY Subseries, and μ PD780001
System clock	Main system clock: 10 MHz Subsystem clock: 32.768 kHz
Clock supply	External: Pulse input Internal: Mounted on emulation board
Low-voltage support	2 V or higher (same as target device)

[MEMO]

CHAPTER 2 PART NAMES

This chapter introduces the parts of the IE-78018-NS-EM1 main unit.

The packing box contains the emulation board (IE-78018-NS-EM1).

If there are any missing or damaged items, please contact an NEC sales representative.

Fill out and return the guarantee document that comes with the main unit.

2.1 Parts of Main Unit

Figure 2-1. IE-78018-NS-EM1 Part Names

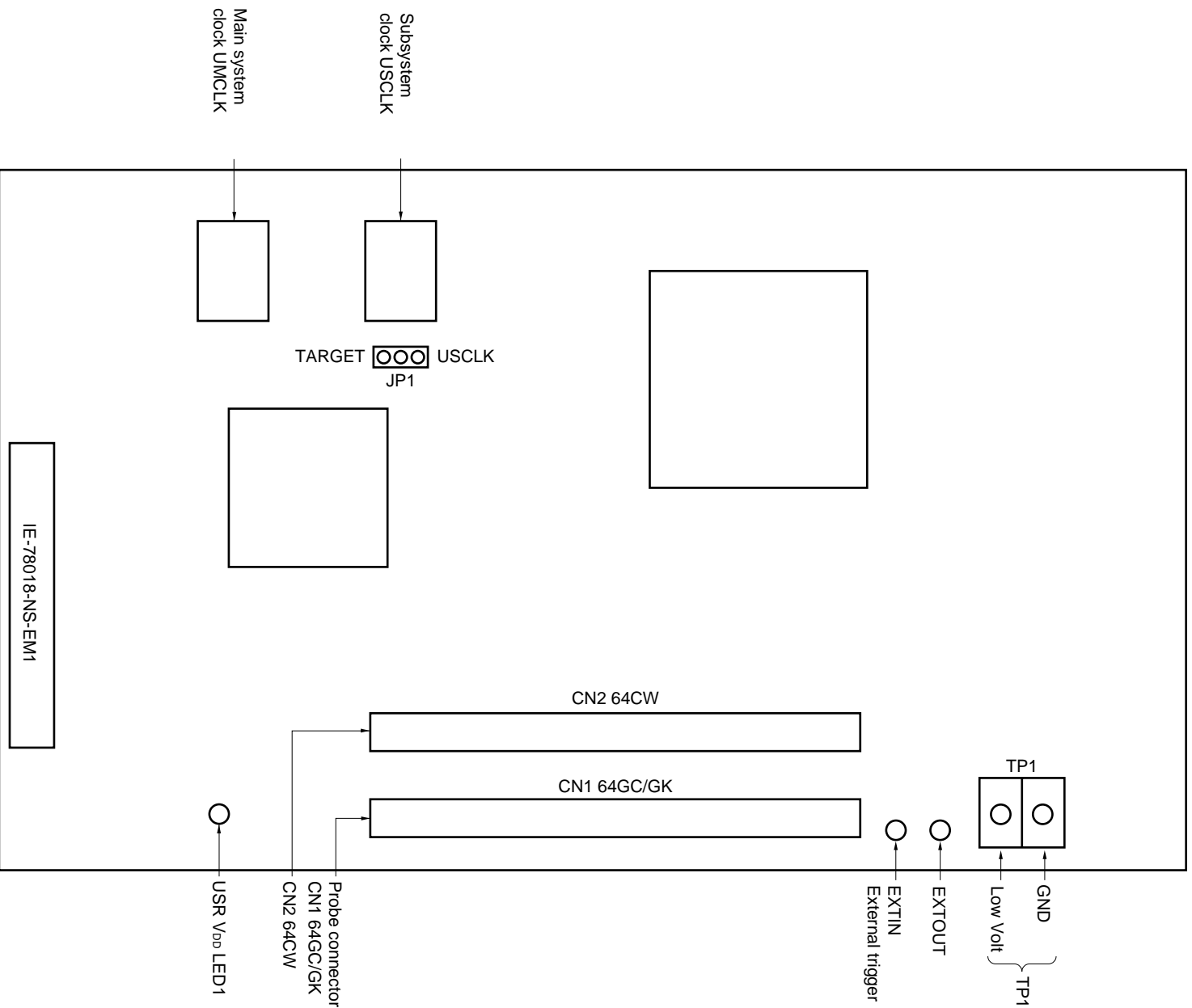

CHAPTER 3 INSTALLATION

This chapter describes methods for connecting the IE-78018-NS-EM1 to the IE-78K0-NS, emulation probe, etc. Mode setting methods are also described.

3.1 Connection

(1) Connection with IE-78K0-NS main unit

See the IE-78K0-NS User's Manual for a description of how to connect the IE-78018-NS-EM1 to the IE-78K0-NS.

(2) Connection with emulation probe

See the IE-78K0-NS User's Manual for a description of how to connect an emulation probe to the IE-78018-NS-EM1.

On this board, however, the probe connector differs depending on the type of the emulation probe used.

- When using NP-64CW, connect it to CN2
- When using NP-64GC or NP-64GK, connect it to CN1

Caution Incorrect connection may damage the IE system.

Be sure to read the emulation probe's user's manual for a detailed description of the connection method.

Figure 3-1. Connection of Emulation Probe

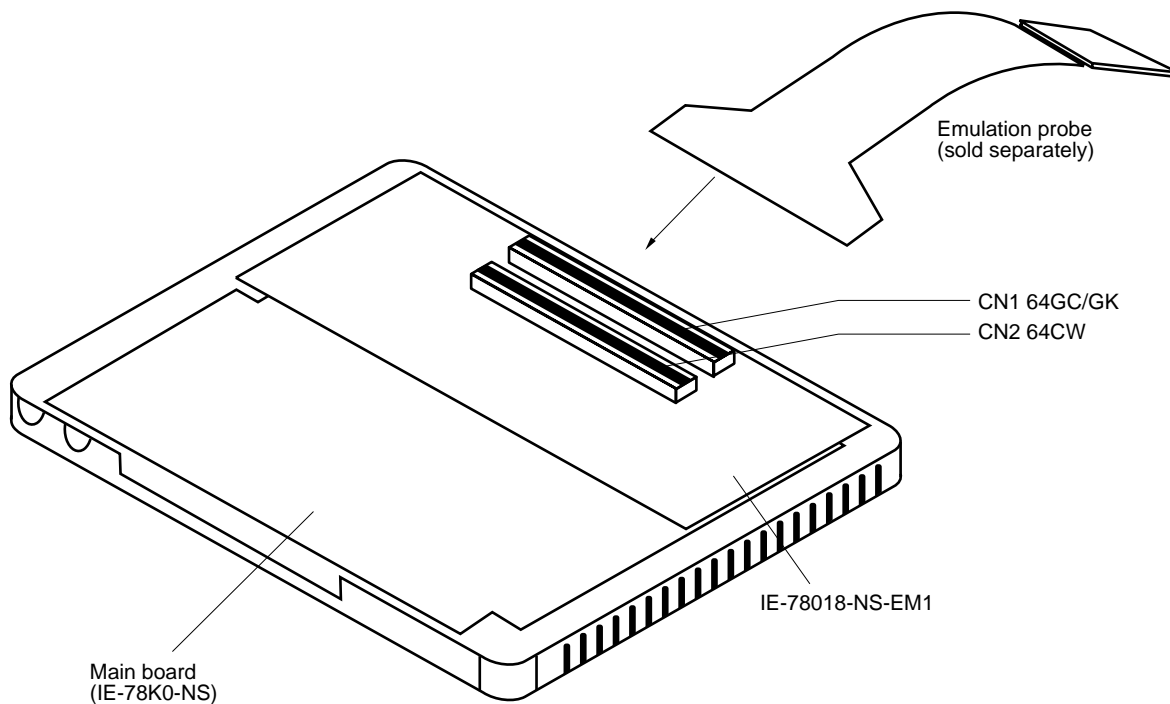

3.2 Clock Settings

3.2.1 Overview of clock settings

The main system and subsystem clocks to be used during debugging can be selected from (1) to (3) below.

- (1) Clock that is already mounted on emulation board
- (2) Clock that is mounted by user
- (3) External clock

If the target system includes an internal clock, select either “(1) Clock that is already mounted on emulation board” or “(2) Clock that is mounted by user”. For an internal clock, the target device is connected to a resonator and the target device’s internal oscillator is used. An example of the external circuit is shown in part (a) of Figure 3-2. During emulation, the resonator that is mounted on the target system is not used. Instead, it uses the clock that is mounted on the emulation board which is installed for the IE-78K0-NS.

If the target system includes an external clock, select “(3) External clock”.

For an external clock, a clock signal is supplied from outside of the target device and the target device’s internal oscillator is not used. An example of the external circuit is shown in part (b) of Figure 3-2.

Figure 3-2. External Circuits Used as System Clock Oscillation Circuit

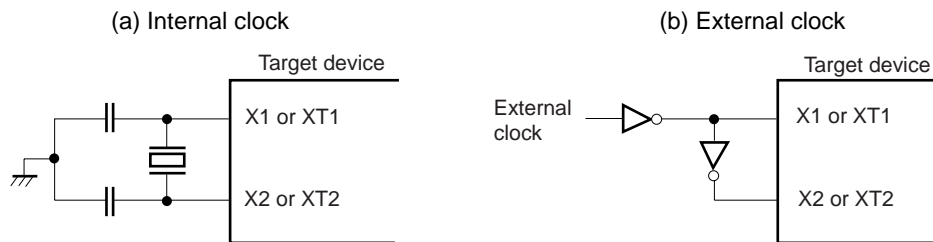

(1) Clock that is already mounted on emulation board

A crystal oscillator is already mounted on the emulation board. Its frequency is 8.3886 MHz.

Figure 3-3. When Using Clock That Is Already Mounted on Emulation Board

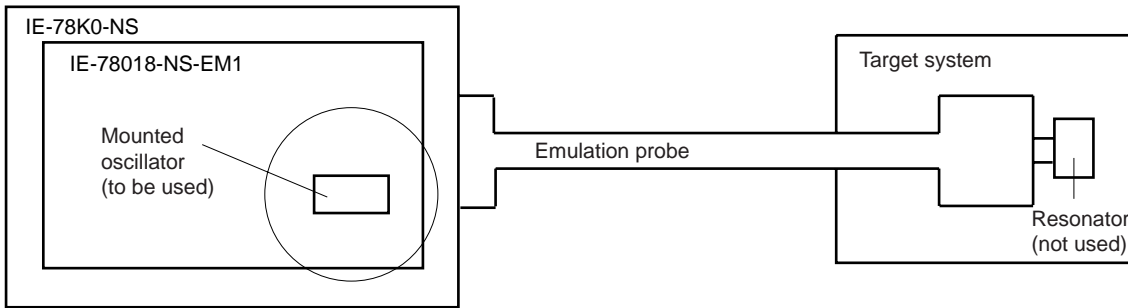

Remark The clock that is supplied by the IE-78018-NS-EM1's oscillator (encircled in the figure) is used.

(2) Clock that is mounted by user

The user is able to mount any clock supported by the set specifications on the IE-78018-NS-EM1. First mount the resonator on the parts board, then attach the parts board to the IE-78018-NS-EM1. This method is useful when using a different frequency from that of the pre-mounted clock.

Figure 3-4. When Using User-mounted Clock

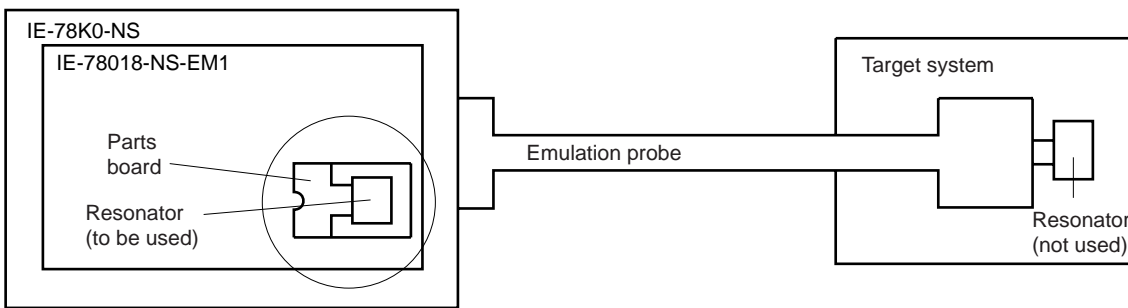

Remark The clock that is supplied by the IE-78018-NS-EM1's resonator (encircled in the figure) is used.

(3) External clock

An external clock connected to the target system can be used via an emulation probe.

Figure 3-5. When Using an External Clock

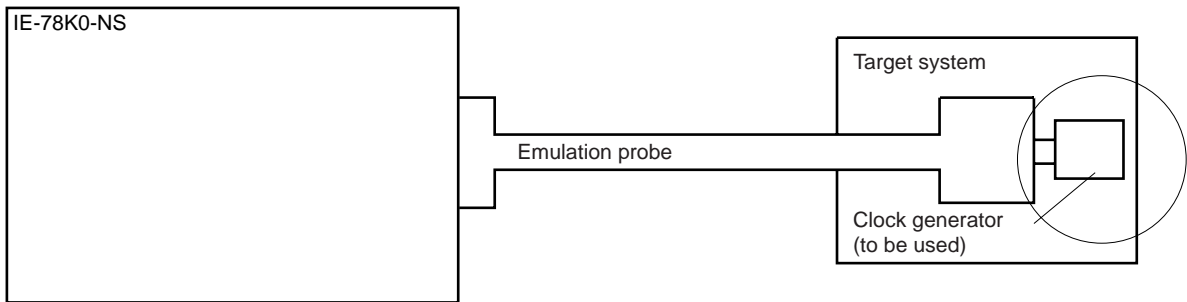

Remark The clock supplied by the target system’s clock generator (encircled in the figure) is used.

3.2.2 Main system clock settings

Table 3-1. Main System Clock Settings

Frequency of Main System Clock		IE-78018-NS-EM1	CPU Clock Source Selection (ID)
		Parts Board (UMCLK)	
When using clock that is already mounted on emulation board	8.38 MHz	Oscillator used	Internal
When using clock mounted by user	Other than 8.38 MHz	Oscillator assembled by user	
When using external clock			Oscillator not used

Caution When using an external clock, open the configuration dialog when starting the integrated debugger (ID78K0-NS) and select “External” in the area (Clock) for selecting the CPU’s clock source (this selects the user’s clock).

Remark The IE-78018-NS-EM1’s factory settings are those listed above under “when using clock that is already mounted on emulation board”.

(1) When using clock that is already mounted on emulation board

When the IE-78018-NS-EM1 is shipped, an 8.38-MHz crystal oscillator is already mounted in the IE-78018-NS-EM1’s UMCLK socket. When using the factory-set mode settings, there is no need to make any other hardware settings.

When starting the integrated debugger (ID78K0-NS), open the configuration dialog box and select “Internal” in the area (Clock) for selecting the CPU’s clock source (this selects the emulator’s internal clock).

(2) When using clock mounted by user

The settings described under either (a) or (b) are required, depending on the type of clock to be used. When starting the integrated debugger (ID78K0-NS), open the configuration dialog box and select "Internal" in the area (Clock) for selecting the CPU's clock source (this selects the emulator's internal clock).

(a) When using a ceramic resonator or crystal resonator

- Items to be prepared
 - Parts board (supplied with IE-78K0-NS)
 - Ceramic resonator or crystal resonator
 - Resistor Rx
 - Capacitor CA
 - Capacitor CB
 - Solder kit

<Steps>

- <1> Solder the target ceramic resonator or crystal resonator, resistor Rx, capacitor CA, and capacitor CB (all with suitable oscillation frequency) onto the supplied parts board (as shown below).

Figure 3-6. Connections on Parts Board (When Using Main System Clock or User-Mounted Clock)

Parts board (UMCLK)

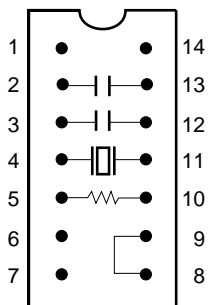

Pin No.	Connection
2-13	Capacitor CB
3-12	Capacitor CA
4-11	Ceramic resonator or crystal resonator
5-10	Resistor Rx
8-9	Short

Circuit diagram

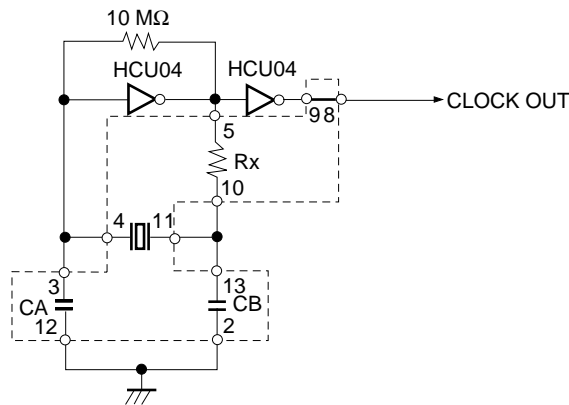

Remark The sections enclosed in broken lines indicate parts that are attached to the parts board.

- <2> Prepare the IE-78018-NS-EM1.
- <3> Remove the crystal oscillator that is mounted in the IE-78018-NS-EM1's socket (the socket marked as UMCLK).
- <4> Connect the parts board (from <1> above) to the socket (UMCLK) from which the crystal oscillator was removed. Check the pin 1 mark to make sure the board is mounted in the correct direction.
- <5> Make sure that the parts board mounted in the UMCLK socket on the emulation board is wired as shown in Figure 3-6 above.
- <6> Install the IE-78018-NS-EM1 in the IE-78K0-NS.

The above steps configure the following circuit and enable supply of the clock from the mounted resonator to the emulation device.

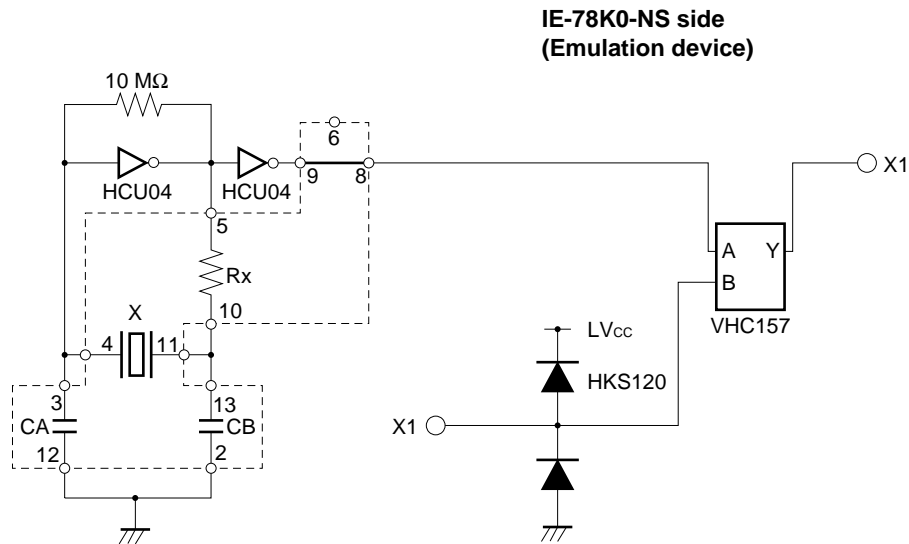

Remark The sections enclosed in broken lines indicate parts that are attached to the parts board.

(b) When using a crystal oscillator

- Items to be prepared
 - Crystal oscillator (see pinouts shown in Figure 3-7)

Figure 3-7. Crystal Oscillator (When Using Main System Clock or User-Mounted Clock)

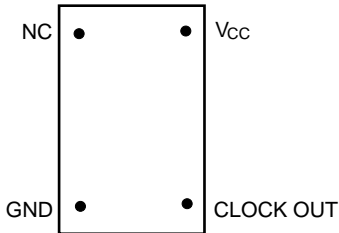

<Steps>

- <1> Prepare the IE-78018-NS-EM1.
- <2> Remove the crystal oscillator that is mounted in the IE-78018-NS-EM1's socket (the socket marked as UMCLK).
- <3> Connect the crystal oscillator (from <2> above) to the socket (UMCLK) from which the crystal oscillator was removed. Insert the crystal oscillator pin into the socket aligning the pins as shown in the figure below.

Figure 3-8. Pin Alignment of Crystal Oscillator and Socket

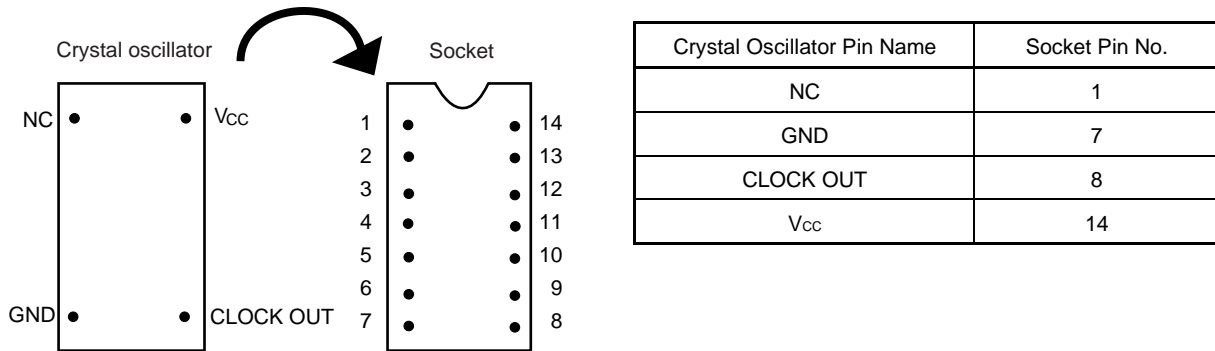

- <4> Install the IE-78018-NS-EM1 in the IE-78K0-NS.

The above steps configure the following circuit and enable supply of the clock from the mounted resonator to the emulation device.

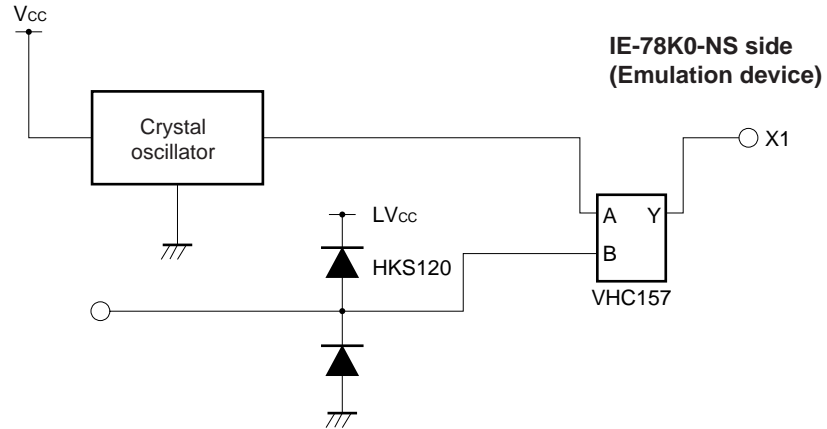

(3) When using external clock

No hardware settings are required for this situation.

When starting the integrated debugger (ID78K0-NS), open the configuration dialog box and select "External" in the area (Clock) for selecting the CPU's clock source (this selects the user's clock).

3.2.3 Subsystem clock settings

Table 3-2. Subsystem Clock Settings

Frequency of Subsystem Clock to be Used		IE-78018-NS-EM1	
		Parts Board (USCLK)	JP1
When using clock that is already mounted on emulation board	32.768 kHz	6 and 8 shorted	Short USCLK side
When using clock mounted by user	Other than 32.768 kHz	Oscillator assembled by user	
When using external clock			Not used

Caution Jumper JP1, which is used to select the board’s clock or an external clock, should be set only after turning off the IE-78K0-NS’s power.

Remark When the IE-78018-NS-EM1 is shipped, the settings for “when using clock that is already mounted on emulation board” are pre-set.

(1) When using clock that is already mounted on emulation board

When the IE-78018-NS-EM1 is shipped, a 32.768-kHz crystal resonator is already mounted on the IE-78018-NS-EM1. Pins 6 and 8 on the parts board (USCLK) are shorted. Short the USCLK side on the IE-78018-NS-EM1’s jumper (JP1). There is no need to make any other settings via the integrated debugger (ID78K0-NS).

(2) When using the clock mounted by user

The settings described under either (a) or (b) are required, depending on the type of clock to be used. Short the USCLK side on the IE-78018-NS-EM1’s jumper (JP1).

There is no need to make any other settings via the integrated debugger (ID78K0-NS).

(a) When using a ceramic resonator or crystal resonator

- Items to be prepared
 - Parts board (supplied with IE-78K0-NS)
 - Ceramic resonator or crystal resonator
 - Resistor Rx
 - Capacitor CA
 - Capacitor CB
 - Solder kit

<Steps>

<1> Solder the target ceramic resonator or crystal resonator, resistor Rx, capacitor CA, and capacitor CB (all with suitable oscillation frequency) onto the supplied parts board (as shown below).

Figure 3-9. Connections on Parts Board (When Using Subsystem Clock or User-Mounted Clock)

Parts board (USCLK)

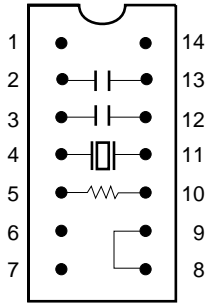

Pin No.	Connection
2-13	Capacitor CB
3-12	Capacitor CA
4-11	Ceramic resonator or crystal resonator
5-10	Resistor Rx
8-9	Short

Circuit diagram

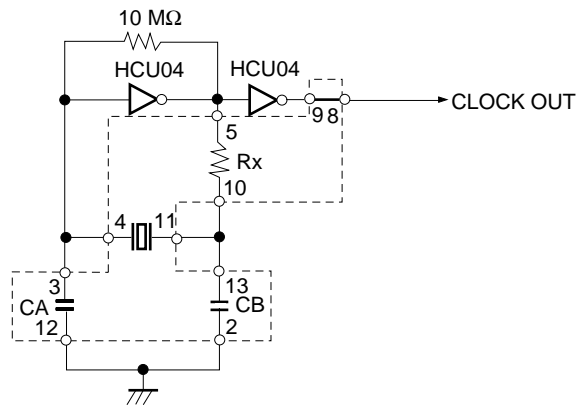

Remark The sections enclosed in broken lines indicate parts that are attached to the parts board.

- <2> Prepare the IE-78018-NS-EM1.
- <3> Remove the parts board that is mounted in the IE-78018-NS-EM1's socket (the socket marked as USCLK).
- <4> Connect the parts board (from <1> above) to the socket (USCLK) from which the parts board was removed (see <3> above). Check the pin 1 mark to make sure the board is mounted in the correct direction.
- <5> Install the IE-78018-NS-EM1 in the IE-78K0-NS.

The above steps configure the following circuit and enable supply of the clock from the mounted resonator to the emulation device.

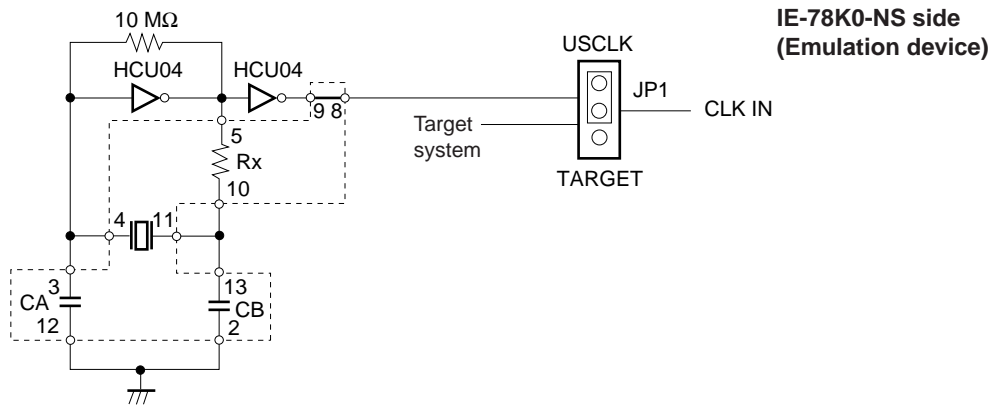

Remark The section enclosed in broken lines indicates parts that are attached to the parts board.

(b) When using a crystal oscillator

- Items to be prepared
 - Crystal oscillator (see pinouts shown in Figure 3-10)

Figure 3-10. Crystal Oscillator (When Using Subsystem Clock or User-Mounted Clock)

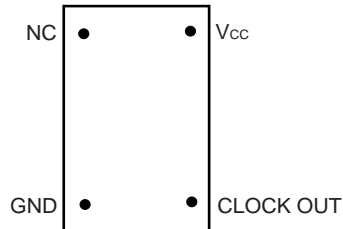

<Steps>

- <1> Prepare the IE-78018-NS-EM1.
- <2> Remove the parts board that is mounted in the IE-78018-NS-EM1's socket (the socket marked as USCLK).
- <3> Connect the crystal oscillator (from <2> above) to the socket (USCLK) from which the parts board was removed. Insert the crystal oscillator pin into the socket aligning the pins as shown in the figure below.

Figure 3-11. Pin Alignment of Crystal Oscillator and Socket

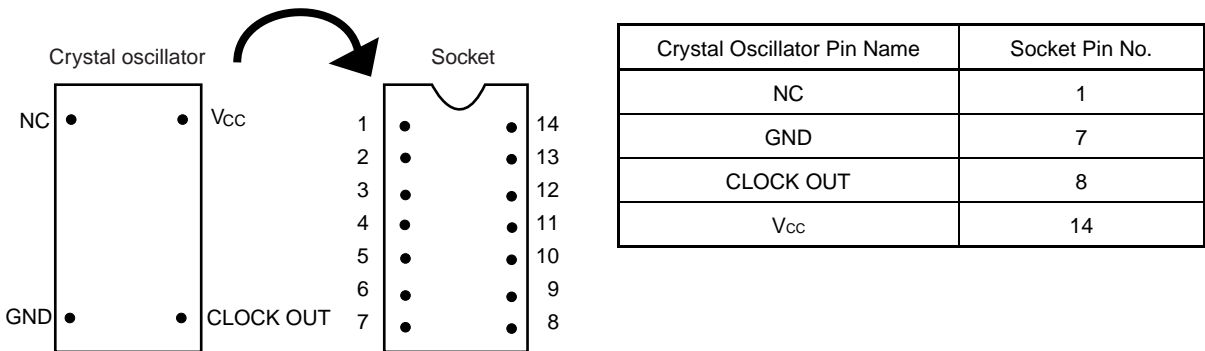

- <4> Install the IE-78018-NS-EM1 in the IE-78K0-NS.

The above steps configure the following circuit and enable supply of the clock from the mounted oscillator to the emulation device.

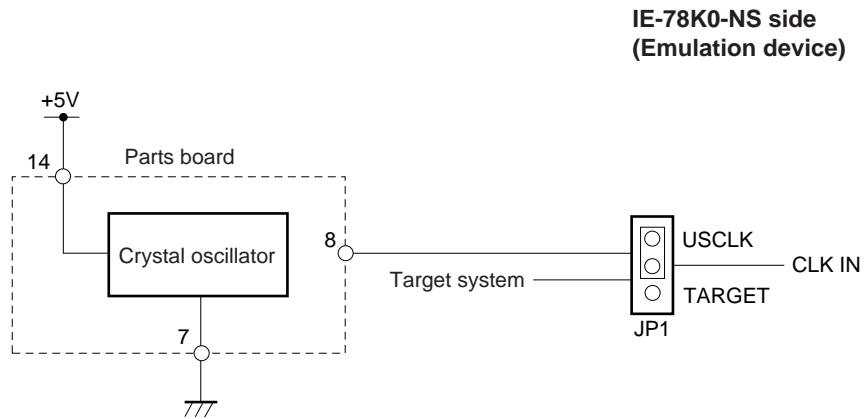

(3) When using an external clock

Short the TARGET side on the IE-78018-NS-EM1's jumper (JP1). There is no need to make any settings via the integrated debugger (ID78K0-NS).

3.3 External Trigger

To set up an external trigger, connect the IE-78018-NS-EM1's check pin, EXTOUT, and EXTIN as shown below.

See the in-circuit emulator (IE-78K0-NS) User's Manual for descriptions of related use methods and pin characteristics.

Figure 3-12. External Trigger Input Position

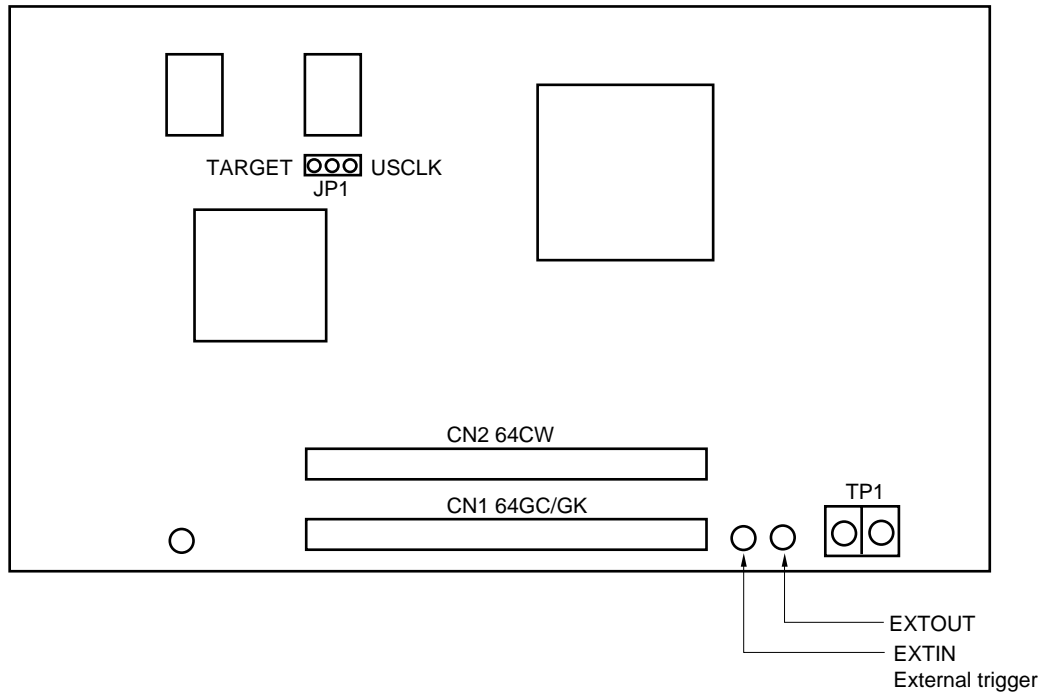

3.4 Jumper Settings on IE-78K0-NS

When using the IE-78018-NS-EM1, set the jumpers on the IE-78K0-NS as shown in **Table 3-3** below. For details of these jumper settings, refer to the IE-78K0-NS User's Manual.

Table 3-3. Jumper Settings on IE-78K0-NS

	JP2	JP3	JP4	JP6	JP7	JP8
Short	2-3	1-2	1-2	3-4	1-2	3-4

CHAPTER 4 DIFFERENCES BETWEEN TARGET DEVICES AND TARGET INTERFACE CIRCUITS

This chapter describes differences between the target device's signal lines and the signal lines of the IE-78018-NS-EM1's target interface circuit.

Although the target device is a CMOS circuit, the IE-78018-NS-EM1's target interface circuit consists of an emulation chip, TTL, CMOS-IC, and other components.

When the IE system is connected with the target system for debugging, the IE system performs emulation so as to operate as the actual target device would operate in the target system.

However, some minor differences exist since the operations are performed via the IE system's emulation.

- (1) Signals input to or output from the emulation chip and the HD151015
- (2) Signals input to or output from the emulation chip and the μ PD78P018
- (3) Other signals

The IE system's circuit is used as follows for signals listed in (1) to (3) above.

(1) Signals input to or output from the level shifter and the HD151015

- Signals related to port 4
- Signals related to port 5
- Signals related to port 6

(2) Signals input to or output from the emulation chip and the μ PD78P018

- Signals related to port 0
- Signals related to port 1
- Signals related to port 2
- Signals related to port 3
- AV_{DD} , AV_{REF} , AV_{SS} ,

(3) Other signals

- V_{DD} , V_{SS} , V_{PP} , X1, X2, XT1, XT2, \overline{RESET} , IC, P63 to P60

Figure 4-1. Equivalent Circuit 1 from Emulation Circuit

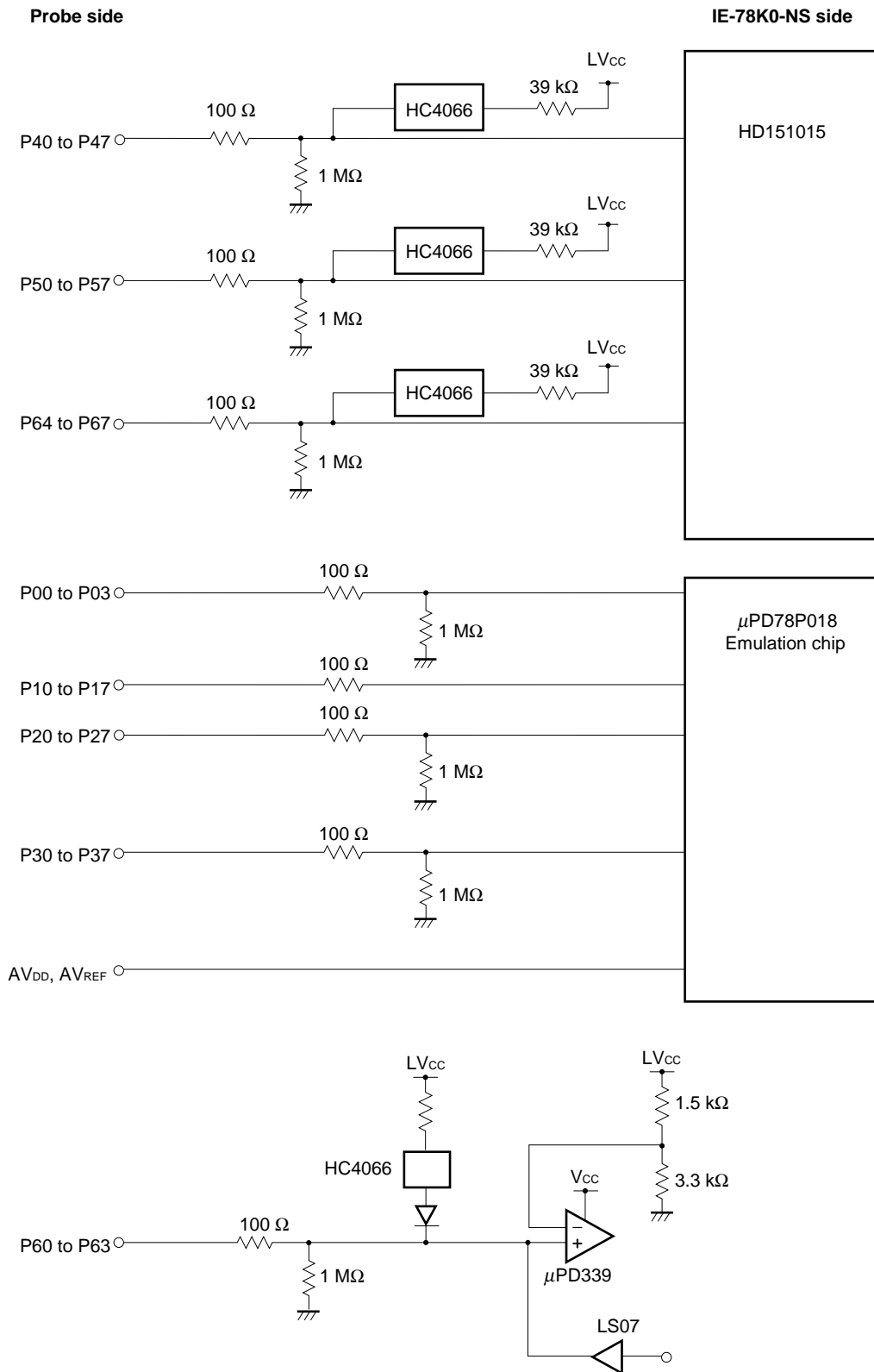
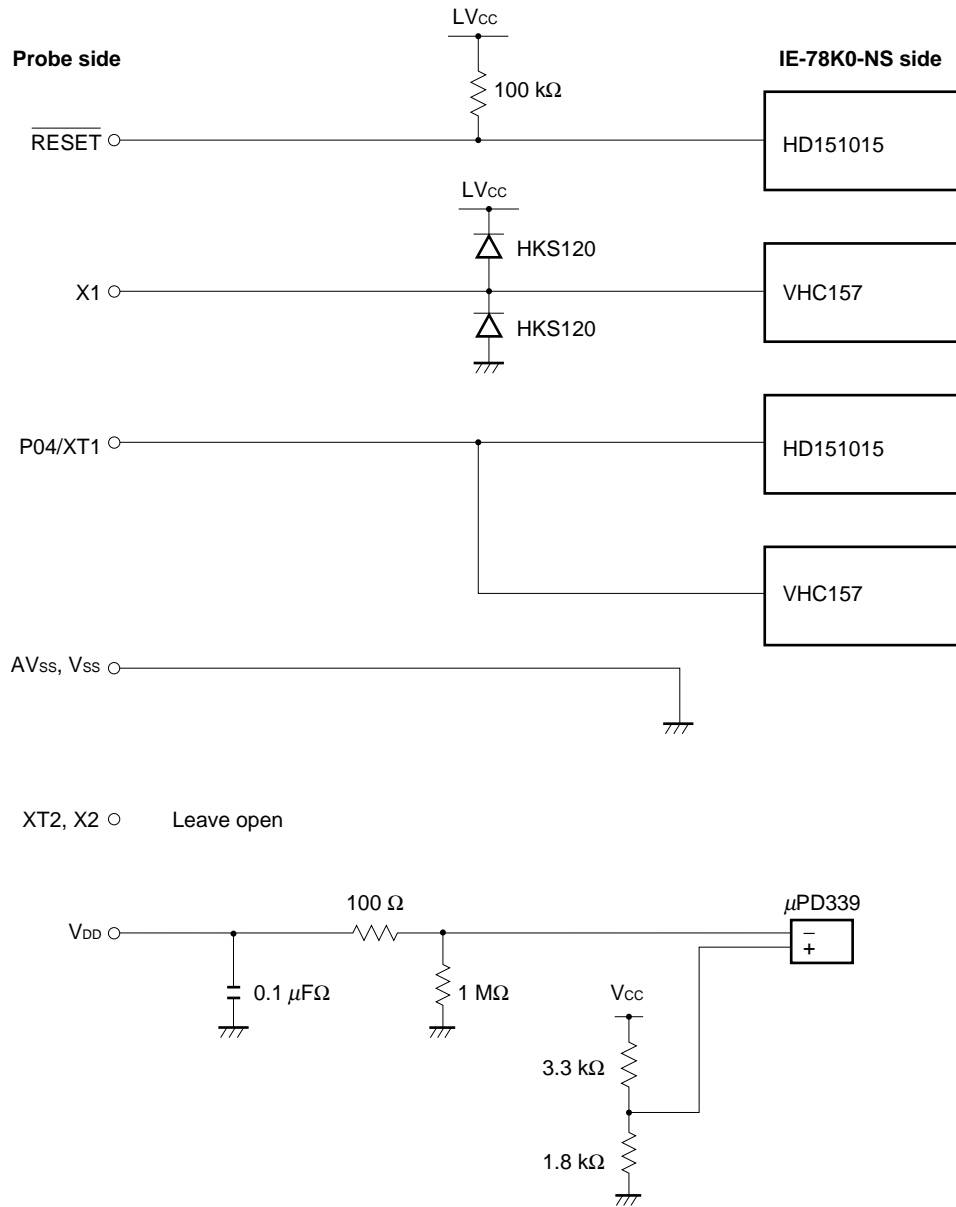

Figure 4-2. Equivalent Circuit 2 from Emulation Circuit



[MEMO]

APPENDIX EMULATION PROBE PIN ASSIGNMENT TABLE

Table A-1. NP-64GC/GK Pin Assignments

Emulation Probe	CN1 Pin No.	Emulation Probe	CN1 Pin No.
1	108	33	14
2	107	34	13
3	104	35	18
4	103	36	17
5	100	37	22
6	99	38	21
7	94	39	28
8	93	40	27
9	30	41	92
10	29	42	91
11	24	43	98
12	23	44	97
13	20	45	102
14	19	46	101
15	16	47	106
16	15	48	105
17	43	49	77
18	44	50	78
19	47	51	73
20	48	52	74
21	51	53	69
22	52	54	70
23	57	55	63
24	58	56	64
25	59	57	61
26	60	58	62
27	55	59	65
28	56	60	66
29	49	61	71
30	50	62	72
31	45	63	75
32	46	64	76

- Remarks**
1. The NP-64GC/GK are products of Naito Densai Machida Seisakusho Co., Ltd.
 2. The numbers in the “Emulation probe” column indicate the corresponding pin number on the emulation probe tip.

Table A-2. NP-64CW Pin Assignments

Emulation Probe	CN2 Pin No.	Emulation Probe	CN2 Pin No.
1	29	33	91
2	24	34	98
3	23	35	97
4	20	36	102
5	19	37	101
6	16	38	106
7	15	39	105
8	43	40	77
9	44	41	78
10	47	42	73
11	48	43	74
12	51	44	69
13	52	45	70
14	57	46	63
15	58	47	64
16	59	48	61
17	60	49	62
18	55	50	65
19	56	51	66
20	49	52	71
21	50	53	72
22	45	54	75
23	46	55	76
24	14	56	108
25	13	57	107
26	18	58	104
27	17	59	103
28	22	60	100
29	21	61	99
30	28	62	94
31	27	63	93
32	92	64	30

- Remarks**
1. The NP-64CW is a product of Naito Densai Machida Seisakusho Co., Ltd.
 2. The numbers in the "Emulation probe" column indicate the corresponding pin number on the emulation probe tip.

[MEMO]

[MEMO]

Facsimile Message

Although NEC has taken all possible steps to ensure that the documentation supplied to our customers is complete, bug free and up-to-date, we readily accept that errors may occur. Despite all the care and precautions we've taken, you may encounter problems in the documentation. Please complete this form whenever you'd like to report errors or suggest improvements to us.

From:

Name

Company

Tel.

FAX

Address

Thank you for your kind support.

North America

NEC Electronics Inc.
Corporate Communications Dept.
Fax: 1-800-729-9288
1-408-588-6130

Hong Kong, Philippines, Oceania

NEC Electronics Hong Kong Ltd.
Fax: +852-2886-9022/9044

Asian Nations except Philippines

NEC Electronics Singapore Pte. Ltd.
Fax: +65-250-3583

Europe

NEC Electronics (Europe) GmbH
Technical Documentation Dept.
Fax: +49-211-6503-274

Korea

NEC Electronics Hong Kong Ltd.
Seoul Branch
Fax: 02-528-4411

Japan

NEC Semiconductor Technical Hotline
Fax: 044-548-7900

South America

NEC do Brasil S.A.
Fax: +55-11-6465-6829

Taiwan

NEC Electronics Taiwan Ltd.
Fax: 02-2719-5951

I would like to report the following error/make the following suggestion:

Document title: _____

Document number: _____ Page number: _____

If possible, please fax the referenced page or drawing.

Document Rating	Excellent	Good	Acceptable	Poor
Clarity	<input type="checkbox"/>	<input type="checkbox"/>	<input type="checkbox"/>	<input type="checkbox"/>
Technical Accuracy	<input type="checkbox"/>	<input type="checkbox"/>	<input type="checkbox"/>	<input type="checkbox"/>
Organization	<input type="checkbox"/>	<input type="checkbox"/>	<input type="checkbox"/>	<input type="checkbox"/>