

**ENHANCED FLOPPY DISK INTERFACE CIRCUIT**

**FEATURES**

- Digital Data Separator  
Performs complete data separation function for floppy disk drives  
Separates FM and MFM encoded data  
No critical adjustments necessary  
3 1/2", 5 1/4" and 8" compatible
- Variable Write Precompensation
- Internal Crystal Oscillator Circuit
- Track-Selectable Write Precompensation
- Retriggerable Head-Load Timer
- Fully compatible with FDC 179X, FDC 765A and FDC 7265
- 16-Bit Cell Divide Algorithm Improves Performance
- Fabricated in Low Power CMOS
- Single +5 Volt Supply
- TTL Compatible; Fully Compatible with the FDC 9229

**PIN CONFIGURATION**

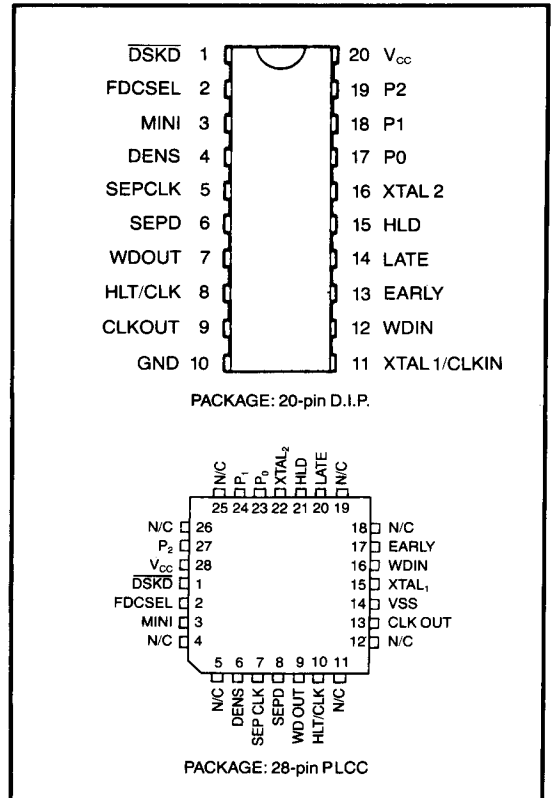

**FUNCTIONAL DESCRIPTION**

The FDC 92C39 is a CMOS integrated circuit designed to complement either the 179X or 765 (8272) type of floppy disk controller chip. It incorporates a digital data separator, write precompensation logic, and a head-load timer in one 0.3-inch wide 20-pin package. A single pin will configure the chip to work with either the 179X or 765 type of controller. The FDC 92C39 provides a number of different dynamically selected precompensation values so that different

values may be used when writing to the inner and outer tracks of the floppy disk drive. The FDC 92C39 operates from a +5V supply.

The FDC 92C39 is available in four versions: the FDC 92C39/T which is intended for 5 1/4" drives and the FDC 92C39B/T for 3 1/2", 5 1/4", and 8" drives. (The /T versions require a TTL clock input.)

SECTION VI

## DESCRIPTION OF PIN FUNCTIONS

PIN NO.	SYMBOL	I/O	DESCRIPTION
1	DSKD	I	This input is the raw read data received from the drive. (This input is active low.)
2	FDCSEL	I	This input signal, when low, programs the FDC 92C39 for a 179X type of LSI controller. When FDCSEL is high, the FDC 92C39 is programmed for a 765 (8272) or 7265 floppy disk controller. (See fig. 4.)
3	MINI	I	The state of this input determines whether the FDC 92C39 is configured to support 8" or 5¼" floppy disk drive interfaces. It is used in conjunction with the DENS input to prescale the clock for the data separator. The state of this input also alters the CLKOUT frequency, the precompensation value, the head load delay time (when in 179X mode) and the HLT/CLK frequency (when in 765 mode). See figs. 2, 3, and 4.)
4	DENS	I	The state of this input determines whether the FDC 92C39 is configured to support single density (FM) or double density (MFM) floppy disk drive interfaces. It is used in conjunction with the MINI input to prescale the clock for the data separator. The state of this input also alters the CLKOUT frequency when in the 765 mode. (See figs. 2, 3, and 4.)
5	SEPCLK	O	A square-wave window clock signal output derived from the DSKD input.
6	SEPD	O	This output is the regenerated data pulse derived from the raw data input (DSKD). This signal may be either active low or active high as determined by FDCSEL (pin 2).
7	WDOUT	O	The precompensated WRITE DATA stream to the drive.
8	HLT/CLK	O	When in the 765 mode (FDCSEL high), this output is the master clock to the floppy disk controller. When in the 179X mode, this signal goes high after the head load delay has occurred following the HLD input going high. This output is retriggerable. (See fig. 3.)
9	CLKOUT	O	This signal is the write clock to the floppy disk controller. Its frequency is determined by the state of the MINI, DENS and FDCSEL input pins. (See fig. 3.)
10	GND		Ground
11	XTAL 1/CLKIN	I	This input is for direct connection to a 16 MHz or 8 MHz single-phase TTL-level clock, or one lead from an 8 MHz or 16 MHz crystal.
12	WDIN	I	The write data stream from the floppy disk controller.
13	EARLY	I	When this input is high, the current WRITE DATA pulse will be written early to the disk.
14	LATE	I	When this input is high, the current WRITE DATA pulse will be written late to the disk. When both EARLY and LATE are low, the current WRITE DATA pulse will be written at the nominal position.
15	HLD	I	This input is only used in 179X mode. A high level at this input causes a high level on the HLT/CLK output after the specified head-load time delay has elapsed. The delay is selected by the state MINI output. (See fig. 3.) In 765 mode this pin must not be forced high.
16	XTAL 2	I	The second lead from an 8 MHz or 16 MHz crystal is connected to this pin. In those applications, using a TTL clock, this pin should be left floating.
17	P0	I	P2-P0 select the amount of precompensation applied to the write data. (See fig. 2.)
18	P1	I	
19	P2	I	
20	V <sub>cc</sub>		+ 5 VOLT SUPPLY

## OPERATION

### Data Separator

The CLKIN input clock is internally divided by the FDC 92C39 to provide an internal clock. The division ratio is selected by the FDCSEL, MINI and DENS inputs depending on the type of drive used. (See fig. 1.)

The FDC 92C39 detects the leading (negative) edges of the disk data pulses and adjusts the phase of the internal clock to provide the SEPCLK output.

Separate short- and long-term timing correctors assure accurate clock separation.

The SEPCLK frequency is nominally  $\frac{1}{32}$  the internal clock frequency. Depending on the internal timing correction, the duration of any SEPCLK half-cycle may vary from a nominal of 16 to a minimum of 12 and a maximum of 21 internal clock cycles.

INPUTS			DIVISOR $f(\text{CLKIN})/f(\text{INTCLK})$
FDCSEL	DENS	MINI	
0	0	0	1
0	0	1	2
0	1	0	2
0	1	1	4
1	0	0	2
1	0	1	4
1	1	0	1
1	1	1	2

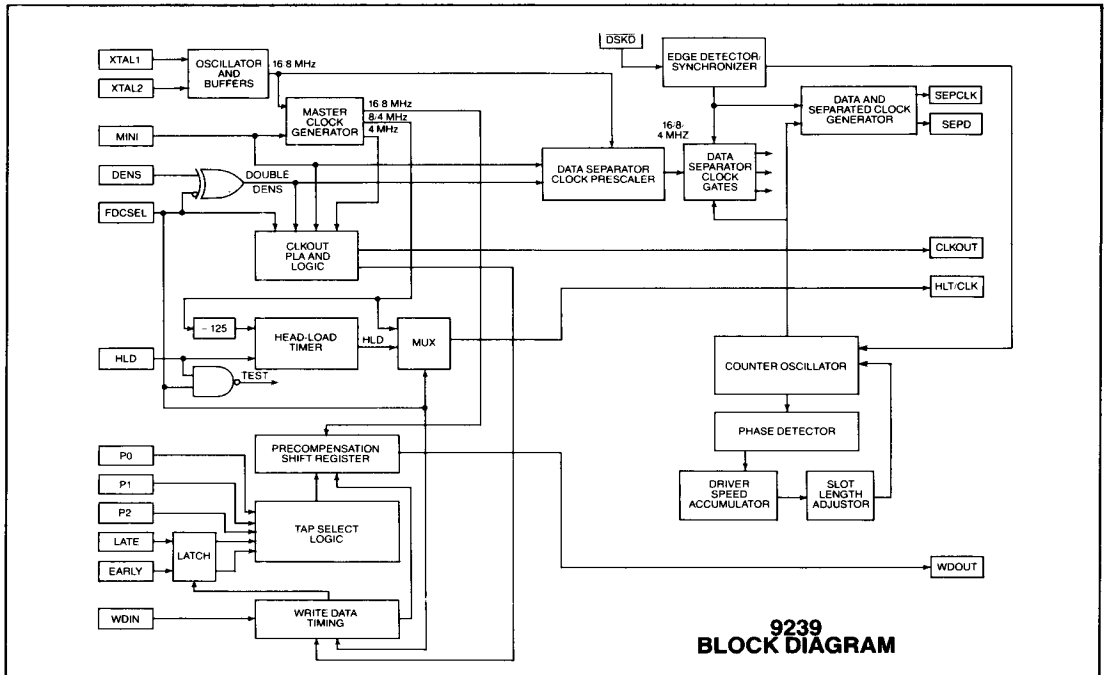
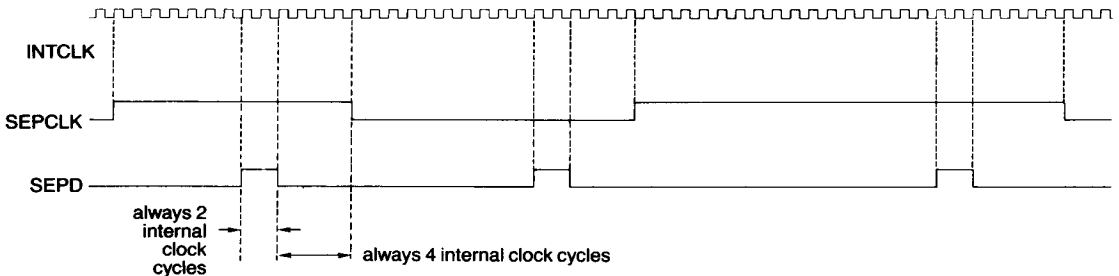

**9239  
BLOCK DIAGRAM**

## OPERATION (CONT'D)

### Precompensation

The desired precompensation delay is determined by the state of the P0, P1 and P2 inputs of the FDC 92C39 as per fig. 2. Logic levels present on these pins may be changed dynamically as long as the inputs are stable during the time the floppy disk controller is writing to the drive and the inputs meet the minimum setup time with respect to the write data from the floppy disk controller.

### Head Load Timer

The head load time delay is either 40 ms or 80 ms, depending on the state of MINI. (See fig. 3.) The purpose of this delay is to ensure that the head has enough time to engage properly. The head load timer is only used in the 179X mode; it is non-functional in the 765 or 7265 mode.

The FDC 179X initiates the loading of the floppy disk drive head by setting HLD high. The controller then waits the programmed amount of time until the HLT signal from the FDC 92C39 goes high before starting a read or write operation.

MINI	P2	P1	P0	PRECOMP VALUE
0	0	0	0	0 ns
0	0	0	1	62.5 ns
0	0	1	0	125 ns
0	0	1	1	187.5 ns
0	1	0	0	250 ns
0	1	0	1	250 ns
1	0	0	0	0 ns
1	0	0	1	125 ns
1	0	1	0	250 ns
1	0	1	1	375 ns
1	1	0	0	500 ns
1	1	0	1	500 ns
1	1	1	0	625 ns
1	1	1	1	625 ns

NOTE: All values shown are obtained with a 16 MHz reference clock. Multiply pre-comp values by two for 8 MHz operation.

**FIG. 2 WRITE PRECOMPENSATION VALUE SELECTION**

INPUTS			OUTPUTS				CONTROLLER
FDCSEL	DENS	MINI	CLKOUT	HLT/CLK	16 MHZ INPUT CLOCK	8 MHZ INPUT CLOCK	
0	0	0	2 MHz	40 ms*	8" Double Density	5¼" Double Density	179X
0	0	1	1 MHz	80 ms*	5¼" Double Density	Not Permitted	179X
0	1	0	2 MHz	40 ms*	8" Single Density	5¼" Single Density	179X
0	1	1	1 MHz	80 ms*	5¼" Single Density	Not Permitted	179X
1	0	0	500 KHz	8 MHz	8" Single Density	5¼" Single Density	765 (8272)
1	0	1	250 KHz	4 MHz	5¼" Single Density	Not Permitted	765 (8272)
1	1	0	1 MHz	8 MHz	8" Double Density	5¼" Double Density	765 (8272)
1	1	1	500 KHz	4 MHz	5¼" Double Density	Not Permitted	765 (8272)

NOTE: 3½" drive users should consult drive specifications to determine if drive data rate equals 5.25" or 8" standards.

\*NOTE: All values shown are obtained with a 16 MHz reference clock. Divide all frequencies and multiply all periods by two for 8 MHz operation.

**FIG. 3 CLOCK/HEAD LOAD TIME DELAY AND FLOPPY DISK DRIVE/CONTROLLER SELECTION**

**MAXIMUM GUARANTEED RATINGS\***

Operating Temperature Range .....	0°C to + 70°C
Storage Temperature Range .....	-55°C to + 150°C
Lead Temperature (soldering, 10 sec.) .....	+ 300°C
Positive Voltage on any I/O Pin, with respect to ground .....	V <sub>CC</sub> + 0.3V
Negative Voltage on any I/O Pin, with respect to ground .....	-0.3V
Maximum V <sub>CC</sub> .....	+ 7V
Power Dissipation .....	0.25W

\*Stresses above those listed may cause permanent damage to the device. This is a stress rating only and functional operation of the device at these or at any other condition above those indicated in the operational sections of this specification is not implied.

NOTE: When powering this device from laboratory or system power supplies, it is important that the Absolute Maximum Ratings not be exceeded or device failure can result. Some power supplies exhibit voltage spikes or "glitches" on their outputs when the AC power is switched on and off. In addition, voltage transients on the AC power line may appear on the DC output. If this possibility exists, it is suggested that a clamp circuit be used.

**ELECTRICAL CHARACTERISTICS (T<sub>A</sub> = 0°C to 70°C, V<sub>CC</sub> = 5V ± 5%)**

PARAMETER	MIN	TYP	MAX	UNIT	CONDITIONS
<b>DC CHARACTERISTICS</b>					
<b>INPUT VOLTAGE</b>					
Low Level V <sub>IL</sub>	-0.3		0.8	V	Except CLKIN
High Level V <sub>IH</sub>	2.0		(V <sub>CC</sub> )	V	
<b>XTAL/CLKIN INPUT VOLTAGE</b>					
Low (V <sub>IL</sub> )	-0.3		1.5	V	
High (V <sub>IH</sub> )	3.2		(V <sub>CC</sub> )	V	
<b>OUTPUT VOLTAGE</b>					
Low Level V <sub>OL</sub>			0.4	V	I <sub>OL</sub> = 1.6 mA except HLT/CLK I <sub>OL</sub> = 0.4 mA, HLT/CLK only I <sub>OH</sub> = -100 µA except HLT/CLK I <sub>OH</sub> = -400 µA, HLT/CLK only
High Level V <sub>OH</sub>	2.4			V	
<b>POWER SUPPLY CURRENT</b>					
I <sub>CC</sub>			20	mA	
<b>INPUT LEAKAGE CURRENT</b>					
I <sub>IL</sub>			10	µA	V <sub>IN</sub> = 0 to V <sub>CC</sub>
<b>INPUT CAPACITANCE</b>					
C <sub>IN</sub>		TBD		pF	Except CLKIN CLKIN only

**PRELIMINARY**  
Notice: This is not a final specification.  
Some parametric limits are subject to change.

SECTION VI

**ELECTRICAL CHARACTERISTICS (T<sub>A</sub> = 0°C to 70°C, V<sub>CC</sub> = 5V ± 5%)**

PARAMETER	MIN	TYP	MAX	UNIT	CONDITIONS
<b>AC ELECTRICAL CHARACTERISTICS</b>					
(All times assume XTAL/CLKIN = 16 MHz unless otherwise specified)					
CLKIN frequency	3.95	16	16.2	MHz	FDC 92C39B
	3.95	8	8.1	MHz	FDC 92C39
CLKIN DUTY CYCLE	40		60	%	
t <sub>CLKH</sub>	465	500	515	ns	FDCSEL = low; MINI = high
	215	250	265	ns	FDCSEL = low; MINI = low
	90	125	140	ns	FDCSEL = high
t <sub>w00</sub>	150	312.5	350	ns	Time Doubles with MINI-t
t <sub>ci</sub>	50		400	ns	
t <sub>INEC</sub>	0		400	ns	
t <sub>w0E</sub>	500	562.5		ns	9 clock times ± 1 clock time
t <sub>w0N</sub>		precomp value			See fig. 2
t <sub>w0L</sub>		2 x precomp value			See fig. 2
t <sub>3</sub>	1.0			µs	

**PRELIMINARY**  
Notice: This is not a final specification.  
Some parametric limits are subject to change.

## AC TIMING CHARACTERISTICS

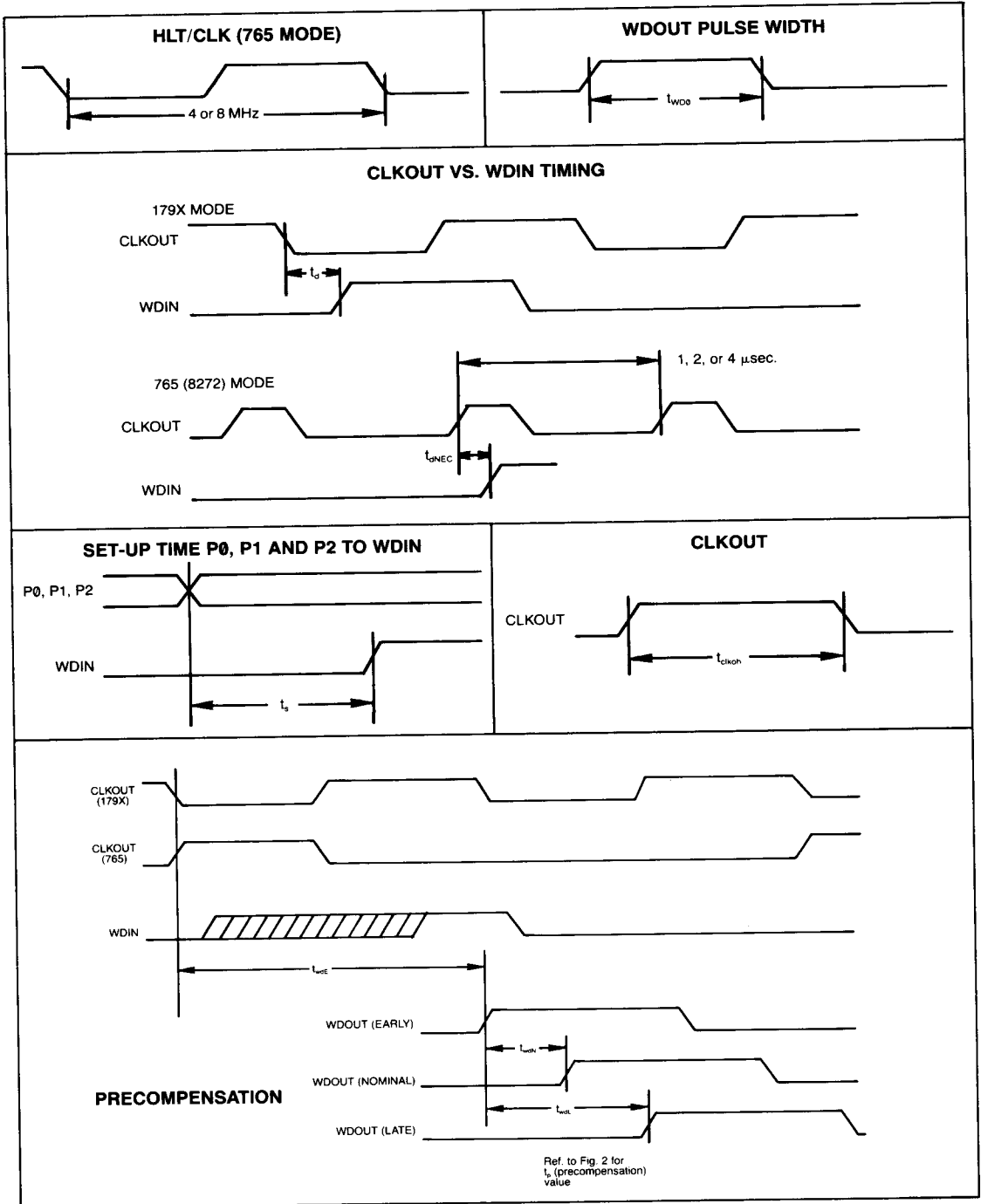

## TYPICAL SYSTEM IMPLEMENTATION—765 (8272) FDC OR 7265 FDC

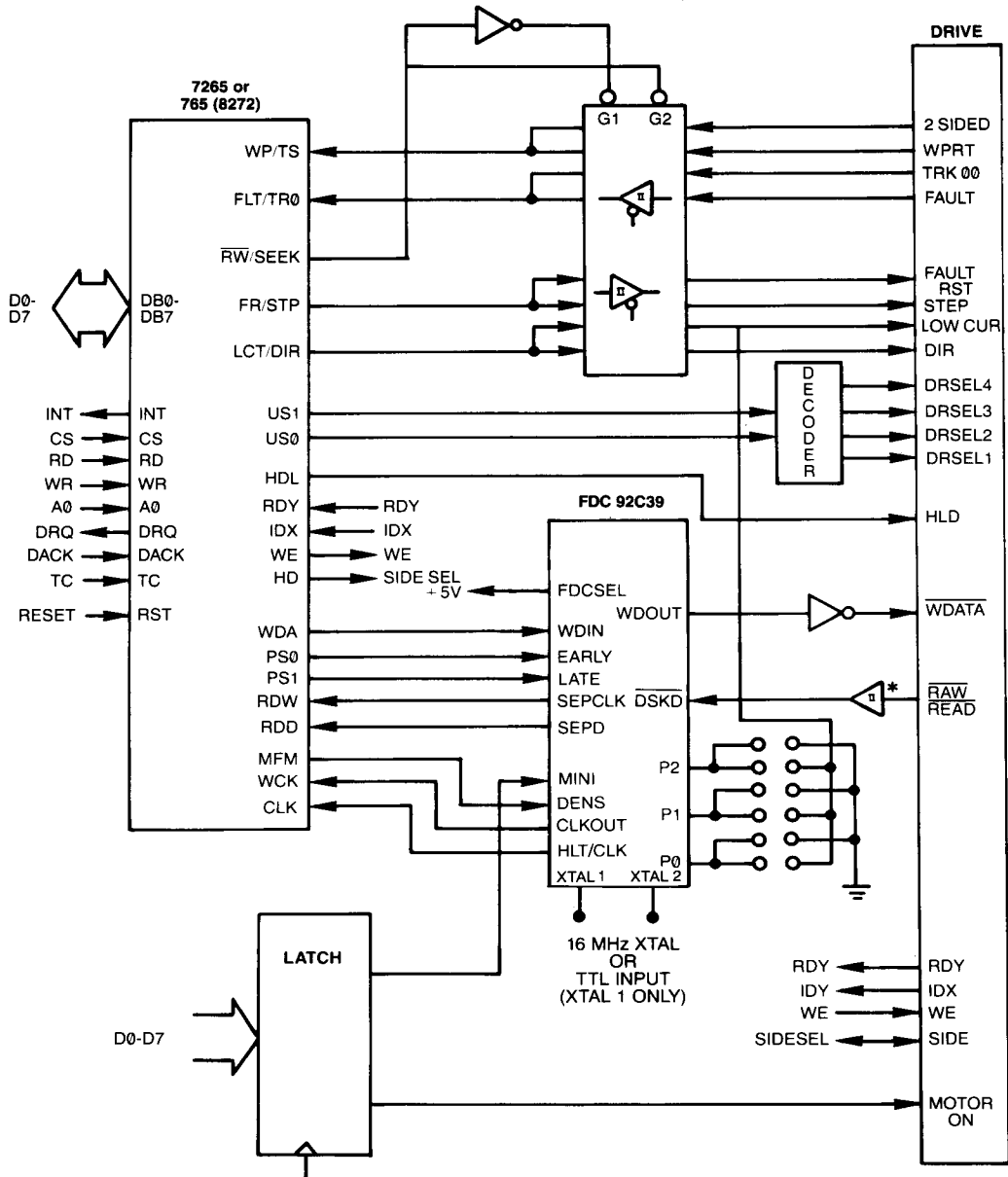

\*The FDC 92C39/B, as all other NMOS integrated circuits, presents a high impedance on all inputs.  
 To avoid soft errors caused by transmission line effects and noise where there is long cabling between the floppy disk drive and the controller board, the use of a (non-inverting) TTL schmidt-trigger input gate or bus transceiver is recommended at the DSKD input to the FDC 92C39/B.

## TYPICAL SYSTEM IMPLEMENTATION—179X FDC OR 979X FDC

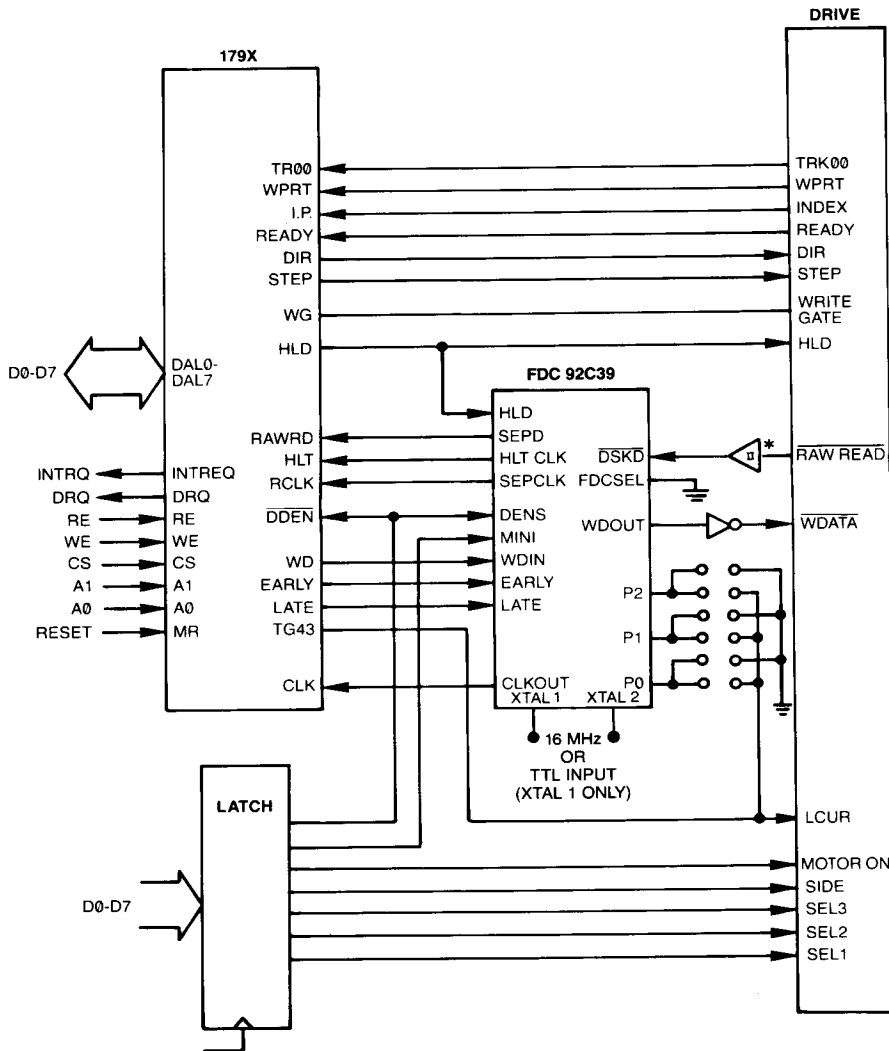

\*The FDC 92C39/B, as all other CMOS integrated circuits, presents a high impedance on all inputs.

To avoid soft errors caused by transmission line effects and noise where there is long cabling between the floppy disk drive and the controller board, the use of a (non-inverting) TTL schmidt-trigger input gate or bus transceiver is recommended at the DSKD input to the FDC 92C39/B.

**STANDARD MICROSYSTEMS CORPORATION**  
25 Marcus Blvd. Hauppauge, NY 11788  
 (516) 273-3100 FAX 516 271-8996

Circuit diagrams utilizing SMC products are included as a means of illustrating typical semiconductor applications; consequently complete information sufficient for construction purposes is not necessarily given. The information has been carefully checked and is believed to be entirely reliable. However, no responsibility is assumed for inaccuracies. Furthermore, such information does not convey to the purchaser of the semiconductor devices described any license under the patent rights of SMC or others. SMC reserves the right to make changes at any time in order to improve design and supply the best product possible.