



Approvals



GAM T1 listed

Life expectancy

L-10 LIFE AT 40°C:
80 000 hours

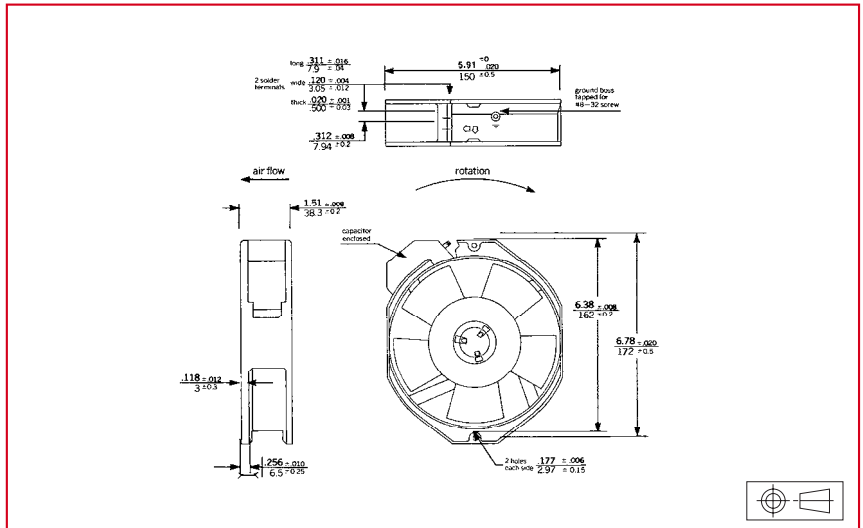

AC Motor

Electrical protection: thermally protected
Housing material: zamak
Impeller material: plastic UL 94 VO
Weight: 1,1 kg

Available with:

- flying leads
- speed sensor

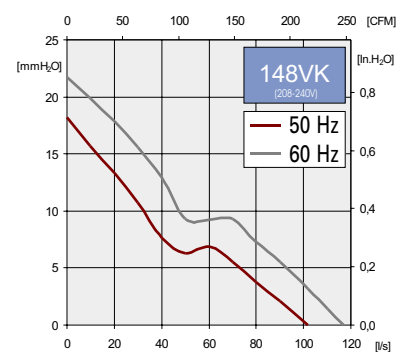
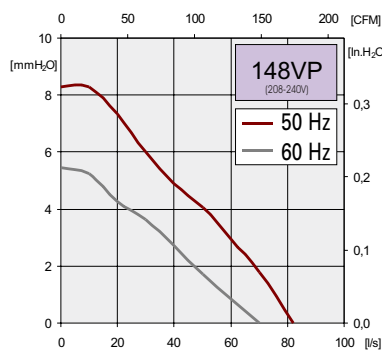
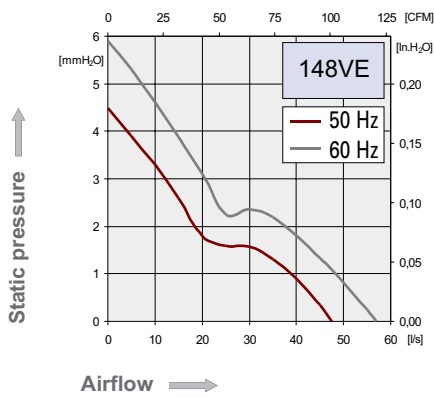

Part number	Nominal voltage	Airflow	Noise level	Nominal speed	Frequency	Phases	Capacitor	Input power	Nominal current	Starting current	Bearing system	Connection type		Operating temperature		
	V	l/s	dB(A)	RPM	Hz		µF	W	mA	mA	Ball	Sleeve	Leads	Terminals	Min. °C	Max. °C
148VE0282030	115	49	36	1400	50	1	1	11	100	140	X		X		- 10	70
		58	39	1650	60	1	1	11	90	140	X		X		- 10	70
148VE0281030	208-240	49	36	1400	50	1	0,32	13	60	80	X		X		- 10	70
		58	39	1650	60	1	0,32	14	60	80	X		X		- 10	70
148VP0282030	115	81	50	2350	50	1	2,2	14	120	170	X		X		- 10	70
		70	45,5	2100	60	1	2,2	18	160	180	X		X		- 10	70
148VP0281030	208-240	82	49	2400	50	1	0,69	16	70	100	X		X		- 10	70
		70	44	2000	60	1	0,69	22	100	105	X		X		- 10	70
148VK0282030	115	100	54	2850	50	1	2,7	32	300	610	X		X		- 10	70
		119	57	3300	60	1	2,7	32	270	590	X		X		- 10	70
148VK0281030	208-240	100	53	2800	50	1	2,2	35	200	390	X		X		- 10	55
		117	57	3200	60	1	2,2	33	170	370	X		X		- 10	55

Additional versions:

Shock & vibration protected - salt spray protected
Wide temperature range - sleeve bearings - marine specifications

Accessories:

- Plastic filter P/N : F172/T102
- Plastic finger guards P/N : PFG-172
- Speed nuts P/N: Speed nuts 6-32
- Metal filters: 120-402, 120-702 & 120-722
- Power cords 9601-36 (several models)