

**PLEASE CHECK WWW.MOLEX.COM FOR LATEST PART INFORMATION**

**Part Number:** **0008580125**  
**Status:** **Active**  
**Overview:** kk  
**Description:** 3.96mm (.156") Pitch KK® Crimp Terminal 2578, 22-26 AWG, Reel, Phosphor Bronze, 0.51µm (20µ") Selective Gold (Au)

**Documents:**

[Drawing \(PDF\)](#) [RoHS Certificate of Compliance \(PDF\)](#)  
[Product Specification PS-08-50 \(PDF\)](#)

**General**

Product Family Crimp Terminals  
 Series 2578  
 Crimp Quality Equipment Yes  
 Overview kk  
 Product Name KK®

**Physical**

Gender Female  
 Material - Metal Phosphor Bronze  
 Material - Plating Mating Gold  
 Packaging Type Reel  
 Plating min: Mating (µin) 15  
 Plating min: Mating (µm) 0.38  
 Termination Interface: Style Crimp or Compression  
 Wire Insulation Diameter 1.65mm (.065") max.  
 Wire Size AWG 22, 24, 26  
 Wire Size mm² N/A

**Material Info**

Old Part Number 2578-B-(550)

**Reference - Drawing Numbers**

Product Specification PS-08-50  
 Sales Drawing SD-2578

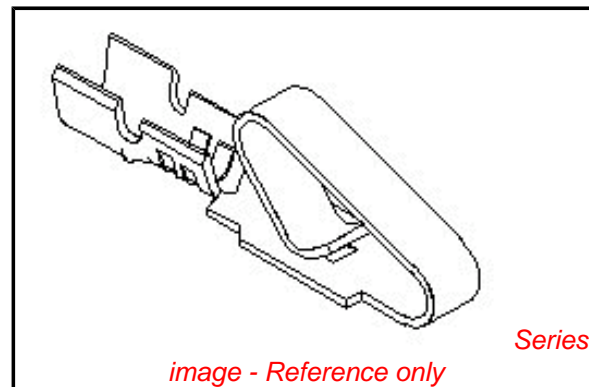

*image - Reference only*

**EU RoHS**

**ELV and RoHS  
 Compliant**  
**REACH SVHC  
 Contains SVHC: No**  
**Halogen-Free  
 Status**

**China RoHS**



**Need more information on product  
 environmental compliance?**

Email [productcompliance@molex.com](mailto:productcompliance@molex.com)  
 For a multiple part number RoHS Certificate of  
 Compliance, [click here](#)

Please visit the [Contact Us](#) section for any  
 non-product compliance questions.

**Search Parts in this Series**

[2578Series](#)

**Use With**

[2574](#) , [2139](#) , [41695](#) , [3069](#) , [6422](#) , [5265](#) ,  
[5239](#)

**Application Tooling | FAQ**

*Tooling specifications and manuals are  
 found by selecting the products below.  
 Crimp Height Specifications are then  
 contained in the Application Tooling  
 Specification document.*

**Global**

Description	Product #
HAND CRIMP TOOL	<a href="#">0638117400</a>
Mini-Mac™ Applicator	<a href="#">0638881000</a>
Extraction Tool	<a href="#">0011030016</a>
Terminator Die	<a href="#">0011402097</a>

**PLEASE CHECK [WWW.MOLEX.COM](http://WWW.MOLEX.COM) FOR LATEST PART INFORMATION**

- NOTES:
1. CRIMP ACCEPTS 22 TO 26 GA. WIRE WITH (.165)/.065 MAX INSULATION DIA.
  2. DIMENSIONS GIVEN ACROSS CENTERLINES ARE SYMMETRICAL ABOUT THOSE CENTERLINES WITHIN HALF THE TOTAL TOLERANCE.
  3. OPTIONAL DESIGN (.86+.05)/.034+.002
  4. TERMINAL CONFORMS TO PRODUCT SPEC. 08-50.
  5. CAT EAR OPTION TO BE USED WITH 41695 HOUSING ONLY.

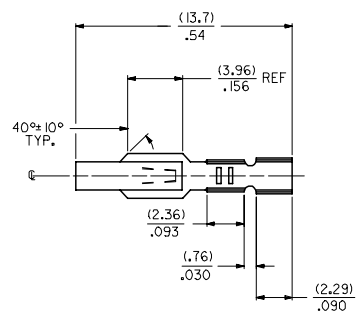
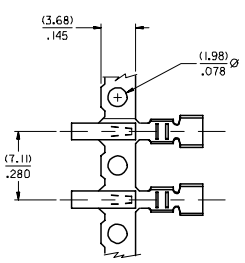
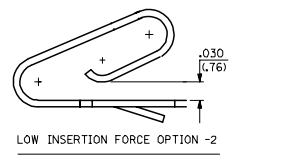
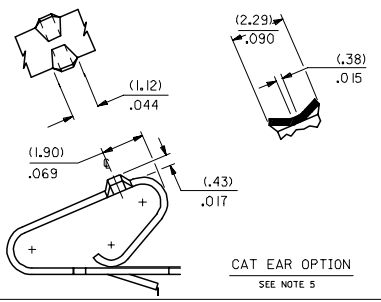

MATERIAL CODE  
 (.28)/.0106 THK  
 BLANK=BRASS  
 B=PHOS BRONZE

WINDING SPEC.  
 A=PER ES-339-A  
 BLANK=PER ES-339-B  
 L=LOOSE

PLATING CODE  
 (PER SDES-88)  
 \*(P909) OVERALL HOT TIN DIP: 2.54 MICROMETERS MIN  
 (550) SELECT GOLD: 0.38 MICROMETERS MIN.  
 OVERALL GOLD FLASH: 0.05 MICROMETERS MIN.  
 OVERALL NICKEL UNDERPLATE: 0.76 MICROMETERS MIN.  
 (555) SELECT GOLD: 0.38 MICROMETERS MIN.  
 OVERALL NICKEL UNDERPLATE: 0.76 MICROMETERS MIN.

OPTIONS  
 BLANK=AS SHOWN  
 1=WITH CAT EARS  
 2=LOW INSERTION FORCE

\*THE PRIMARY SHIPPING CARTON WILL BE LABELED \*COMPLIANT TO ROHS DIRECTIVE 2002/95/EC AND ELV ANNEX II OF DIRECTIVE 2000/53/EC.\* CARTONS WITHOUT THIS LABEL MAY CONTAIN PRODUCT WITH TIN-LEAD PLATING.

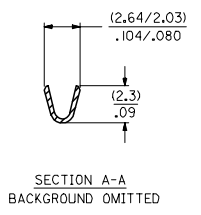
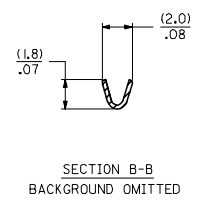
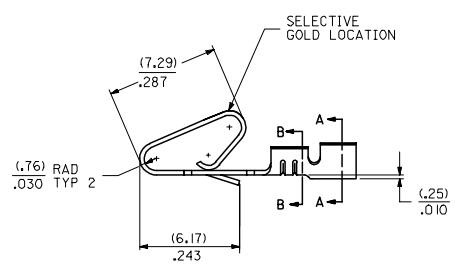
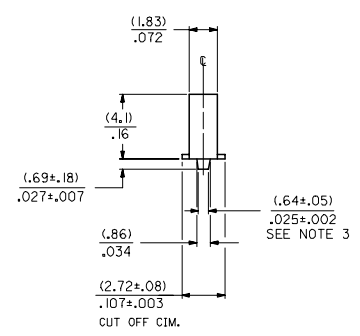

ENTER DESCRIPTION EC NO: UCP2005-0928 DRAWN BY: DRW:ADRIANO CHKD-SAMEC 2004/11/02 APPR:MMRIGALLIS 2004/11/02 W	QUALITY SYMBOLS	GENERAL TOLERANCES (UNLESS SPECIFIED)		DIMENSION STYLE IN/MM		SCALE	DESIGN UNITS INCH	THIRD ANGLE PROJECTION
	▽=0	4 PLACES ±	mm	INCH	DRAWN BY	DATE	TITLE	
	▽=0	3 PLACES ±	± .010		CHECKED BY	DATE	CRIMP TERMINAL	
		2 PLACES ±	± 0.25	± .014	PATEL	01/29/87	(3.96)/.156 CENTERS	
	1 PLACE ±	± 0.36	± .036	APPROVED BY	DATE	22 TO 26 GA WIRE		
		ANGULAR ±1/2°		LENZ	01/29/87	MOLEX INCORPORATED		
	DRAFT WHERE APPLICABLE MUST REMAIN WITHIN DIMENSIONS		SEE CHART		MATERIAL NO.	DOCUMENT NO.	SHEET NO.	
			SIZE D		THIS DRAWING CONTAINS INFORMATION THAT IS PROPRIETARY TO MOLEX INCORPORATED AND SHOULD NOT BE USED WITHOUT WRITTEN PERMISSION			

2578-(***)*		2578-B-(***)*		2578-B-2(***)*							
PART NO.	ENG. NO.	PART NO.	ENG. NO.	PART NO.	ENG. NO.	PART NO.	ENG. NO.	PART NO.	ENG. NO.	PART NO.	ENG. NO.
08-50-0107	2578-(P909)	08-56-0121	2578-B-(501)		2578-B-2(P909)						
08-50-0108	2578-(P909)L	08-56-0122	2578-B-(501)L		2578-B-2(P909)L						
08-50-0111	2578-(109)	08-50-0133 *	2578-B-(P909)		2578-B-2(555)						
08-50-0112	2578-(109)L	08-50-0134 *	2578-B-(P909)L		2578-B-2(555)L						
08-56-0107	2578-(550)	08-65-0116 *	2578-B-(555)		2578-B-2(550)						
08-56-0108	2578-(550)L	08-65-0117 *	2578-B-(555)L		2578-B-2(550)L						
08-55-0105	2578-(555)	08-65-0108	2578-B-(591)								
08-56-0106	2578-(555)L	08-65-0107	2578-B-(591)L								
08-59-0101	2578-(122)	08-60-0003	2578-B-(122)								
	2578-(122)L	08-60-0004	2578-B-(122)L								
1 08-56-0162	2578-(505)	08-65-0110	2578-B-(558)								
1 08-56-0163	2578-(505)L	08-65-0111	2578-B-(558)L								
08-50-0504	2578-(128)	08-58-0125 *	2578-B-(550)								
	2578-(128)L	08-58-0126 *	2578-B-(550)L								
08-56-0161	2578-(503)										
	2578-(503)L										
1 08-50-0061	2578-(224)										
1 08-50-0062	2578-(224)L										
1 08-50-0065	2578-(P224)										
1 08-50-0066	2578-(P224)L										
08-55-0137	2578-(558)A										
	2578-(558)L										
08-50-0018	2578-(102)										
08-50-0019	2578-(102)L										
08-55-0121	2578-(561)										
08-55-0132	2578-(561)L										
08-55-0123	2578-(558)										
	2578-(558)L										
08-65-0109	2578-(555)A										
08-52-0116	2578-(P909)										
08-52-0117	2578-(P9109)L										

CHANGE TO ME10 EC NO: UCP2005-0928 DRW:ADRIANO 2004/11/16 CHK:CSAMEC 2004/11/02 APPR: MARGULLIS 2004/11/02 W	QUALITY SYMBOLS ▽=0 ▽=0	GENERAL TOLERANCES (UNLESS SPECIFIED) <table border="1"> <tr> <th></th> <th>mm</th> <th>INCH</th> </tr> <tr> <td>4 PLACES</td> <td>± .005</td> <td>± .0005</td> </tr> <tr> <td>3 PLACES</td> <td>± .005</td> <td>± .0005</td> </tr> <tr> <td>2 PLACES</td> <td>± .005</td> <td>± .0005</td> </tr> <tr> <td>1 PLACE</td> <td>± .005</td> <td>± .0005</td> </tr> </table>		mm	INCH	4 PLACES	± .005	± .0005	3 PLACES	± .005	± .0005	2 PLACES	± .005	± .0005	1 PLACE	± .005	± .0005	DIMENSION STYLE IN/MM	SCALE INCH	DESIGN UNITS INCH	THIRD ANGLE PROJECTION
		mm	INCH																		
	4 PLACES	± .005	± .0005																		
	3 PLACES	± .005	± .0005																		
2 PLACES	± .005	± .0005																			
1 PLACE	± .005	± .0005																			
DRAWN BY PEREZ/AR	DATE 01/29/87	CHECKED BY PATEL	DATE 01/29/87	APPROVED BY LENZ	DATE 01/29/87	MATERIAL NO. DOCUMENT NO. SD-2578															
DRAFT WHERE APPLICABLE MUST REMAIN WITHIN DIMENSIONS						SIZE D	THIS DRAWING CONTAINS INFORMATION THAT IS PROPRIETARY TO MOLEX INCORPORATED AND SHOULD NOT BE USED WITHOUT WRITTEN PERMISSION														
CRIMP TERMINAL (3,96)/.156 CENTERS 22 TO 26 GA WIRE						MOLEX INCORPORATED	SHEET NO. 2														