

## Dual Channel 500mA Regulator + Reset IC

### Features

- Low Quiescent Current : 130 $\mu$ A (No load)
- Low Dropout Voltage :  
 $V_{DRO P1}=550mV@500mA$   
 $V_{DRO P2}=630mV@500mA$
- Fixed Output Voltage :  
 $V_{OUT1}=3.3V/500mA$   
 $V_{OUT2}=2.5V/500mA$
- Stable with 4.7 $\mu$ F Output Capacitor
- Stable with Aluminum, Tantalum or Ceramic Capacitors
- Reverse Current Protection
- No Protection Diodes Needed
- Built in Thermal Protection
- Fast Transient Response
- Short Setting Time
- SOP-8, SOP-8-P with Thermal Pad Packages
- Adjustment-free Reset Detection Voltage :  
 3.9V or 4.2V typ
- Easy to Set Delay Time from Voltage Detection to Reset Release

### General Description

The APL5525/6 is a dual-channel regulator with reset function (specific voltage monitoring), and internal delay circuit, set to detect 3.9V or 4.2V. Maximum input voltage is 6V, output1 and output2 deliver up to 500mA.  $V_{OUT1}$  typical dropout voltage is 550mV at 500mA loading and  $V_{OUT2}$  typical dropout voltage is 630mV at 500mA loading. Design with an internal P-channel MOSFET pass transistor, the APL5525/6 maintains a low supply current. Other features include, thermal-shutdown protection, current limit protection to ensure specified output current. The APL5525/6 come in miniature SOP-8 and SOP-8-P packages.

### Pin Configuration

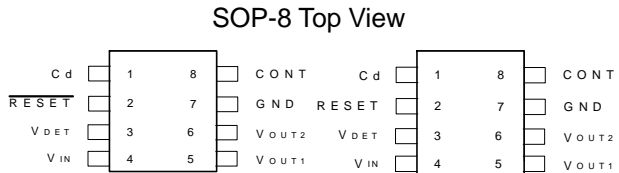

### Applications

- CD-ROM drive.

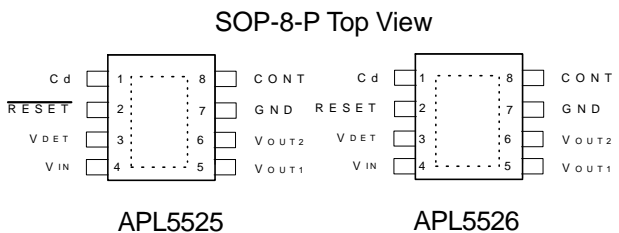

 = Thermal Pad  
 (connected to GND plane for better heat dissipation)

ANPEC reserves the right to make changes to improve reliability or manufacturability without notice, and advise customers to obtain the latest version of relevant information to verify before placing orders.

## Ordering and Marking Information

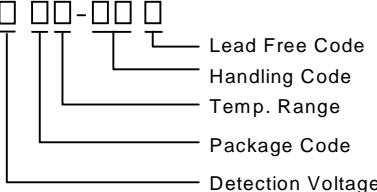
<p>APL5525/6 - </p>	<p>Package Code                  K : SOP-8      KA : SOP-8-P                  Temp. Range                  C : 0 to 70°C                  Handling Code                  TR : Tape &amp; Reel                  Detection Voltage :                  A : 3.9V      B : 4.2V                  Lead Free Code                  L : Lead Free Device                  Blank : Original Device</p>
<p>APL5525/6 K / KA : <span style="border: 1px solid black; padding: 2px;">APL5525/6X XXXXX</span></p>	<p>X      - Detection Voltage                  XXXXX - Date Code</p>

## Pin Description

PIN		I/O	Description
No.	Name		
1	Cd		Delay time capacitor pin, RESET pin output delay time can be set by the capacitor connected to the Cd pin. $t_{PLH} = 130000 * C$ , $t_{PLH}$ : transmission delay time (s), C:capacitor value (F)
2	RESET	O	Input voltage detection output pin , low = $V_{DET} < V_S$ , high = $V_{DET} > V_S$
	RESET	O	Input voltage detection output pin , high = $V_{DET} < V_S$ , low = $V_{DET} > V_S$
3	$V_{DET}$	I	Input pin of voltage detection.
4	$V_{IN}$	I	Voltage supply input pin.
5	$V_{OUT1}$	O	Regulator output pin.
6	$V_{OUT2}$	O	Regulator output pin.
7	GND		GND pin
8	CONT	I	$V_{OUT1}$ on/off-control pin, $V_{OUT1}$ will be turn off when CONT pull to low.

## Absolute Maximum Ratings

Symbol	Parameter	Rating	Unit
$V_{IN}, V_{OUT}$	Input Voltage or Out Voltage	6	V
CONT	$V_{OUT1}$ Shutdown Control Pin	6	V
$V_{DET}$	RESET Pin Supply Voltage	6	V
$R_{TH,JA}$	Thermal Resistance – Junction to Ambient SOP-8 SOP-8-P	160 80	°C/W
$P_D$	Power Dissipation	Internally Limited	W
$T_J$	Operating Junction Temperature Control Section Power Transistor	0 to 125 0 to 150	°C
$T_{STG}$	Storage Temperature Range	-65 to +150	°C
$T_L$	Lead Temperature (Soldering, 10 second)	260	°C

## Electrical Characteristics

Unless otherwise noted these specifications apply over full temperature ,  $V_{IN}=5V$ ,  $C_{IN}=1\mu F$ ,  $C_{OUT1}=4.7\mu F$ ,  $C_{OUT2}=4.7\mu F$ ,  $CONT=V_{IN}$ ,  $T_J=0$  to  $125^{\circ}C$  . Typical values refer to  $T_J=25^{\circ}C$  .

Symbol	Parameter	Test Conditions	APL5525/6			Unit
			Min.	Typ.	Max.	
$V_{IN}$	Input Voltage				6	V
$I_Q$	Quiescent Current	$I_{OUT1}=0mA$ , $I_{OUT2}=0mA$		130		$\mu A$
	Shutdown Supply Current	$CONT = low$ $I_{OUT2}=0mA$ , $V_{IN}=6.0V$		100		$\mu A$
$I_{CONT}$	Shutdown Input Bias current	$V_{CONT}=V_{IN}$			0.1	$\mu A$
$V_{CONT}$	High Threshold Voltage		1.6		$V_{IN}+0.3$	V
	Low Threshold Voltage		-0.3		0.4	
$I_{CCQ}$	$V_{DET}$ Input Current	$V_{DET}=5V$		20	40	$\mu A$
<b>Regulator1</b>						
$V_{OUT1}$	Output Voltage	$V_{IN}=5V$	3.234	3.3	3.366	V
$I_{LIMIT}$	Circuit Current Limit	$V_{IN}=5V$		950		mA
$I_{OUT}$	Load Current		500			mA
$REG_{LINE}$	Line Regulation	$V_{OUT}+0.5V < V_{IN} < 6.0V$ , $I_{OUT}=10mA$		4	6	mV
$REG_{LOAD}$	Load Regulation	$V_{IN}=5V$ , $0mA < I_{OUT} < I_{MAX}$		25	60	mV
$V_{DROP}$	Dropout Voltage <sup>(Note)</sup> ( $V_{OUT}(\text{Nominal})=3.3V$ Version)	$I_{OUT}=500mA$		550	650	mV
PSRR	Ripple Rejection	$F \leq 1kHz$ , 1Vpp at $I_{OUT}=50mA$	45	50		dB
OTS	Over Temperature Shutdown			125		$^{\circ}C$
	Over Temperature Shutdown Hysteresis	Hysteresis		10		$^{\circ}C$
TC	Output Voltage Temperature Coefficient	$T_a = -20 \sim 80^{\circ}C$		100		ppm/ $^{\circ}C$
$C_{OUT}$	Output Capacitor			4.7		$\mu F$
	ESR		0.01		1	Ohm
<b>Regulator2</b>						
$V_{OUT2}$	Output Voltage	$V_{IN}=5V$	2.45	2.5	2.55	V
$I_{LIMIT}$	Circuit Current Limit	$V_{IN}=5V$		950		mA
$I_{OUT}$	Load Current		500			mA

## Electrical Characteristics (Cont.)

Unless otherwise noted these specifications apply over full temperature,  $V_{IN}=5V$ ,  $C_{IN}=1\mu F$ ,  $C_{OUT1}=4.7\mu F$ ,  $C_{OUT2}=4.7\mu F$ ,  $CONT=V_{IN}$ ,  $T_J=0$  to  $125^\circ C$ . Typical values refer to  $T_J=25^\circ C$ .

Symbol	Parameter	Test Conditions	APL5525/6			Unit
			Min.	Typ.	Max.	
REG <sub>LINE</sub>	Line Regulation	$V_{OUT}+0.5V < V_{IN} < 6.0V$ , $I_{OUT}=10mA$		4	6	mV
REG <sub>LOAD</sub>	Load Regulation	$V_{IN}=5V$ , $0mA < I_{OUT} < I_{MAX}$		30	50	mV
$V_{DROP}$	Dropout Voltage <sup>(Note)</sup> ( $V_{OUT}$ (Nominal)=2.5V Version)	$I_{OUT}=500mA$		630	750	mV
PSRR	Ripple Rejection	$F \leq 1kHz$ , 1Vpp at $I_{OUT}=50mA$	45	52		dB
OTS	Over Temperature Shutdown			125		$^\circ C$
	Over Temperature Shutdown Hysteresis	Hysteresis		10		$^\circ C$
TC	Output Voltage Temperature Coefficient	$T_a = -20 \sim 80^\circ C$		100		ppm/ $^\circ C$
$C_{OUT}$	Output Capacitor			4.7		$\mu F$
	ESR		0.01		1	Ohm
<b>RESET / RESET</b>						
VS	Detection Voltage	$V_{DET}=H \rightarrow L$ (APL5525/6A)		3.9		V
		$V_{DET}=H \rightarrow L$ (APL5525/6B)		4.2		
$\Delta VS/\Delta T$	Vs Temperature Coefficient	$T_a = -20 \sim +80^\circ C$		100		ppm/ $^\circ C$
$\Delta VS$	Hysteresis Voltage	$V_{DET} = H \rightarrow L$	130	180	230	mV
$V_{OL}$	Low-level Output Voltage	$V_{DET} = 3.9V$ , $R_L = 4.7k\Omega$		12	60	mV
$I_{OH}$	Output Leakage Current	$V_{DET} = 5V$		0.5	1	$\mu A$
$I_{OL1}$	Output Current1	$V_{DET}=3.9V$ , $V_{RESET} = 0.4V$	25	30		mA
$I_{OL2}$	Output Current2	$V_{DET} = 3.9V$ , $V_{RESET} = 0.4V$ $T_a = -20 \sim +80^\circ C$	20	25		mA
tPLH	"H" Transmission Delay Time	$C_d = 0\mu F$		42	90	$\mu s$
tPLH1	Reset Delay Time	$V_{DET} = 3.7V \rightarrow 5V$ , $C_d = 0.1\mu F$	8	13	18	ms
tPHL	"L" Transmission Delay Time	$C_d = 0\mu F$		4	90	$\mu s$
$V_{OPL}$	Threshold Operating Voltage	$V_{RESET} = 0.4V$		0.95	1.25	V

Note : Dropout voltage definition :  $V_{IN} - V_{OUT}$  when  $V_{OUT}$  is 2% below the value of  $V_{OUT}$  for  $V_{IN}=5V$

### Application Circuit

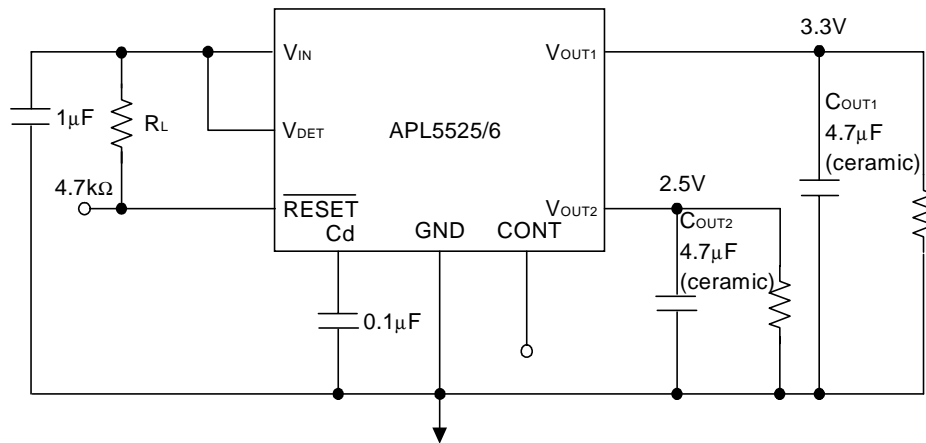

www.DataSheet4U.com

# Timing Chart

APL5525

APL5526

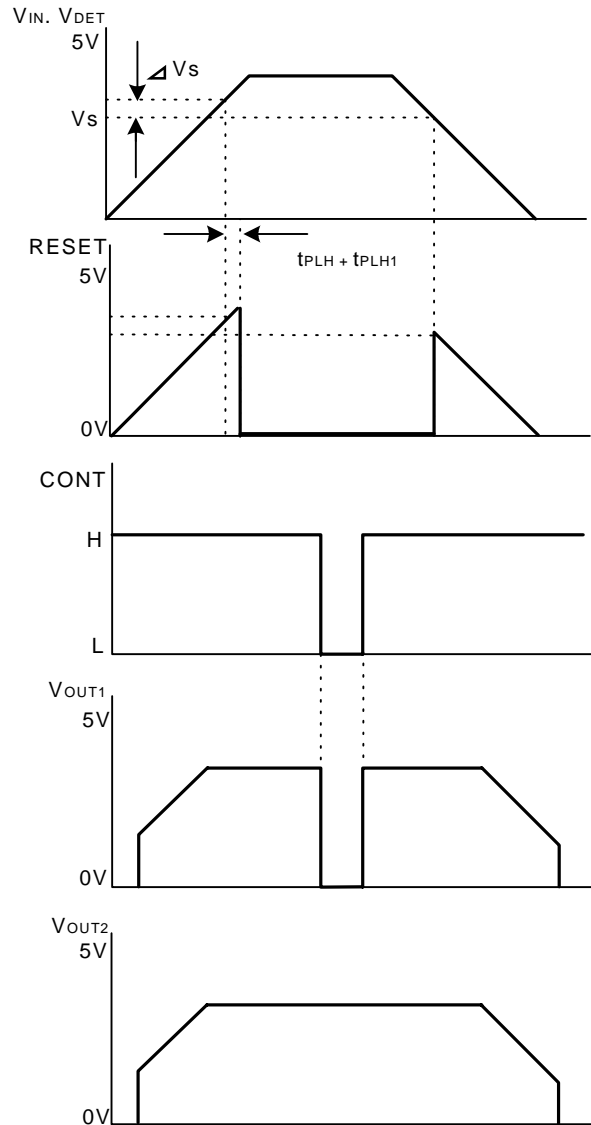
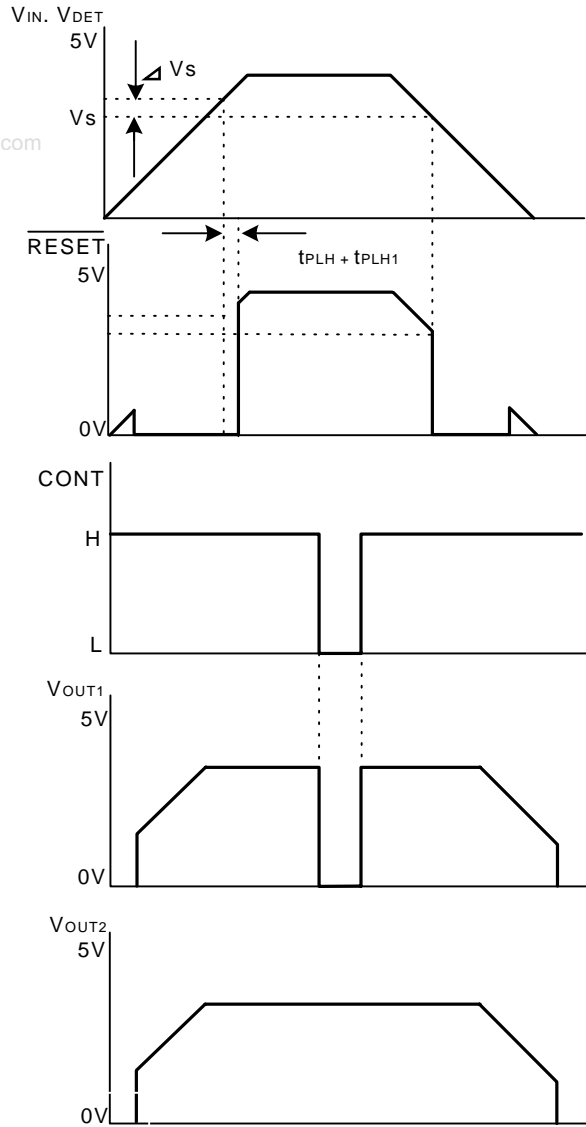

## Typical Characteristics

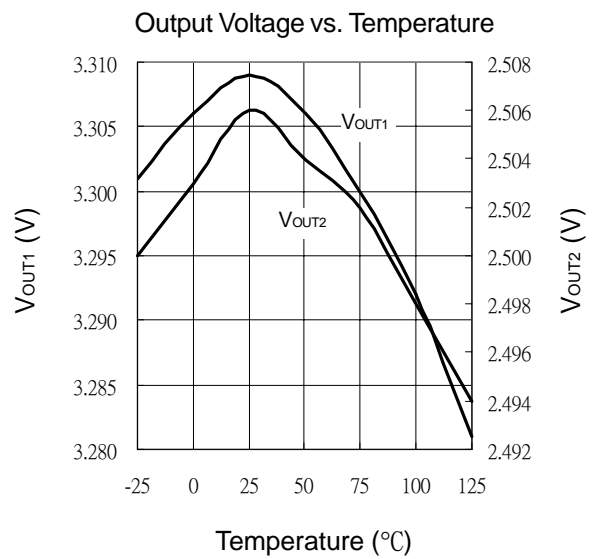
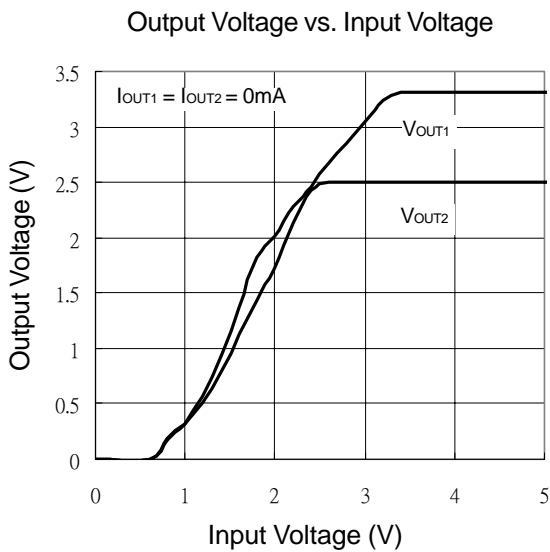
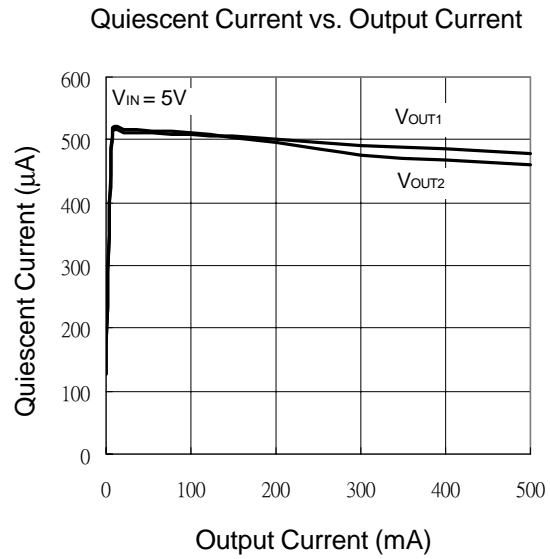
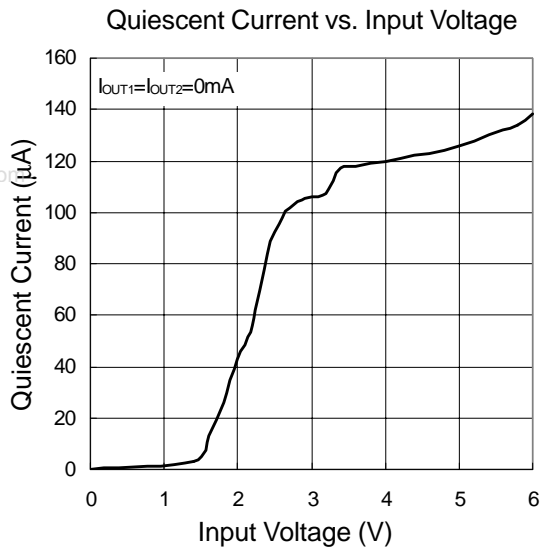

## Typical Characteristics

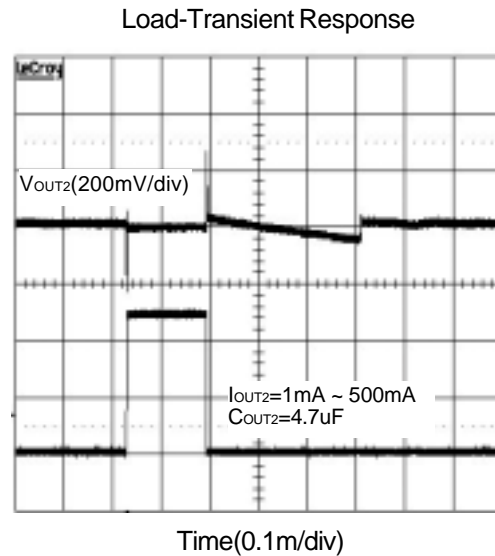
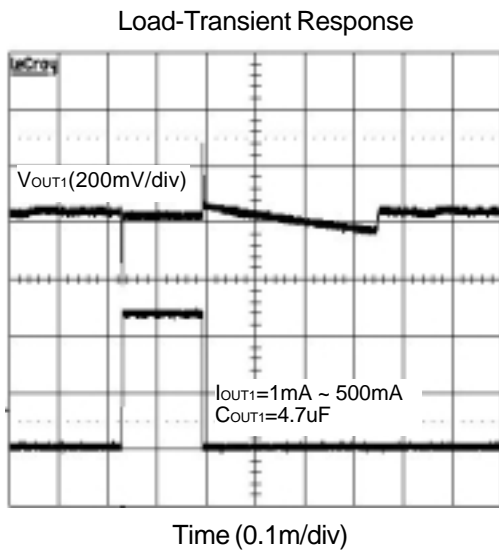
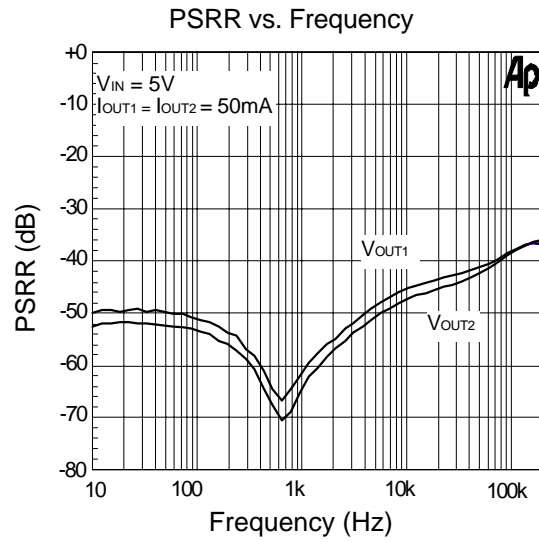
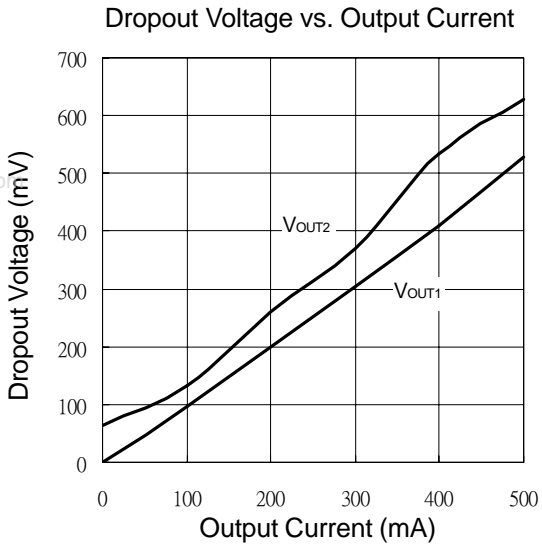



## Typical Characteristics

Line-Transient Response

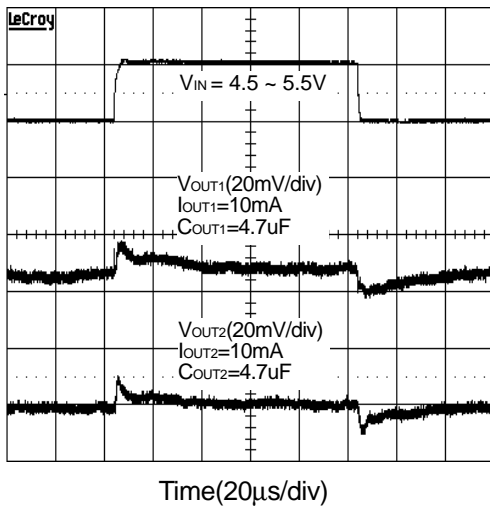

Shutdown Response

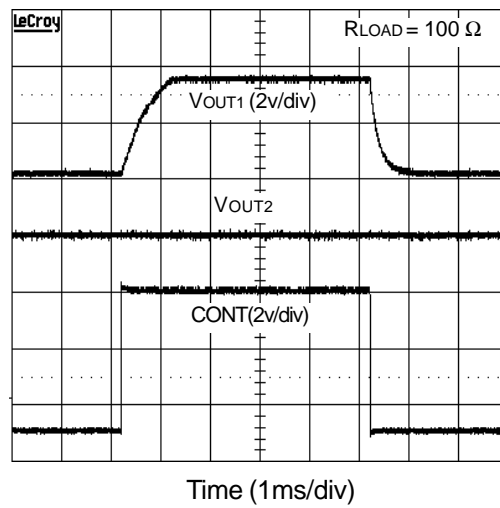

## Packaging Information

SOP-8 pin ( Reference JEDEC Registration MS-012)

www.DataSheet4U.com

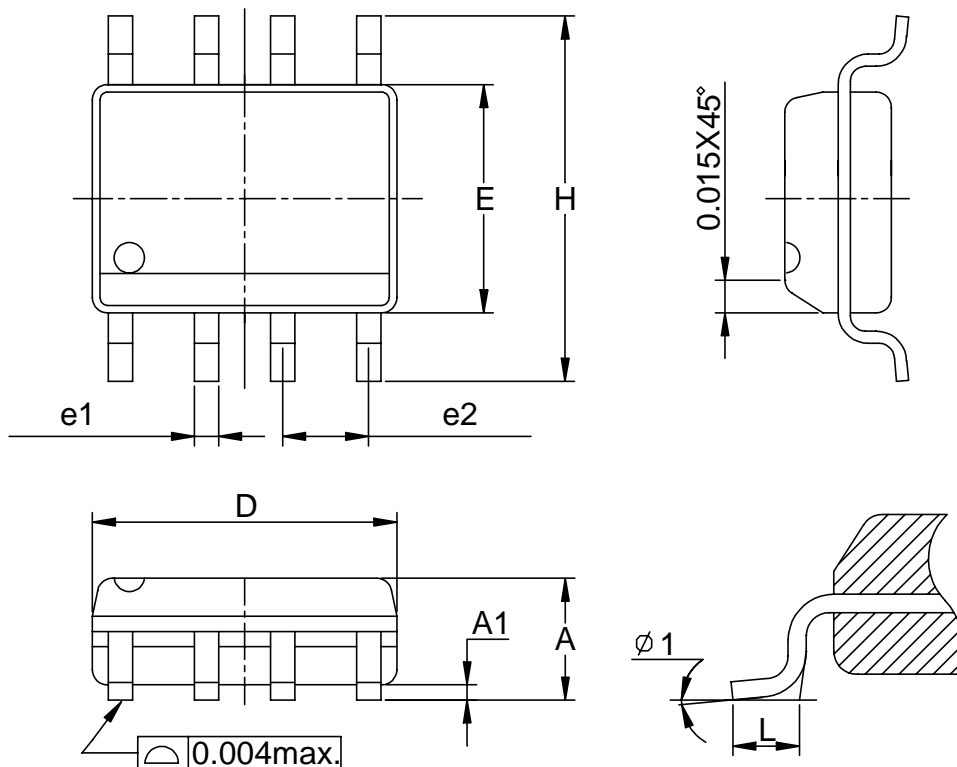

Dim	Millimeters		Inches	
	Min.	Max.	Min.	Max.
A	1.35	1.75	0.053	0.069
A1	0.10	0.25	0.004	0.010
D	4.80	5.00	0.189	0.197
E	3.80	4.00	0.150	0.157
H	5.80	6.20	0.228	0.244
L	0.40	1.27	0.016	0.050
e1	0.33	0.51	0.013	0.020
e2	1.27BSC		0.50BSC	
φ 1	8°		8°	

## Packaging Information

SOP-8-P pin ( Reference JEDEC Registration MS-012)

www.DataSheet4U.com

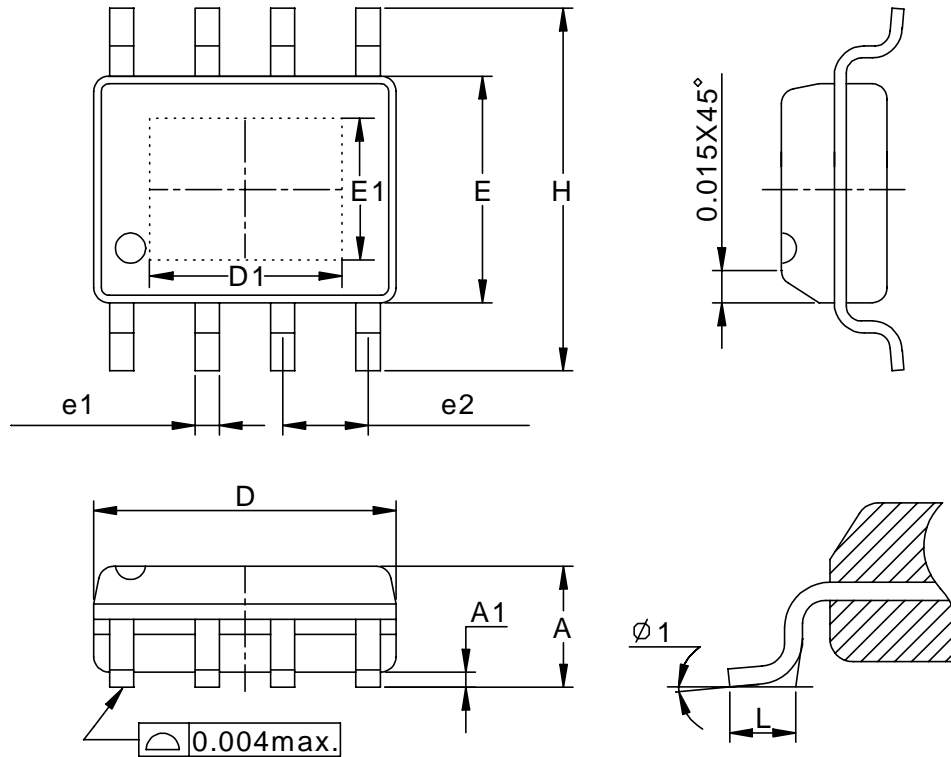

Dim	Millimeters		Inches	
	Min.	Max.	Min.	Max.
A	1.35	1.75	0.053	0.069
A1	0.10	0.25	0.004	0.010
D	4.80	5.00	0.189	0.197
D1	3.00REF		0.118REF	
E	3.80	4.00	0.150	0.157
E1	2.60REF		0.102REF	
H	5.80	6.20	0.228	0.244
L	0.40	1.27	0.016	0.050
e1	0.33	0.51	0.013	0.020
e2	1.27BSC		0.50BSC	
φ 1	8°		8°	

## Physical Specifications

Terminal Material	Solder-Plated Copper (Solder Material : 90/10 or 63/37 SnPb)
Lead Solderability	Meets EIA Specification RSI86-91, ANSI/J-STD-002 Category 3.

## Reflow Condition (IR/Convection or VPR Reflow)

Reference JEDEC Standard J-STD-020A APRIL 1999

www.DataSheet4U.com

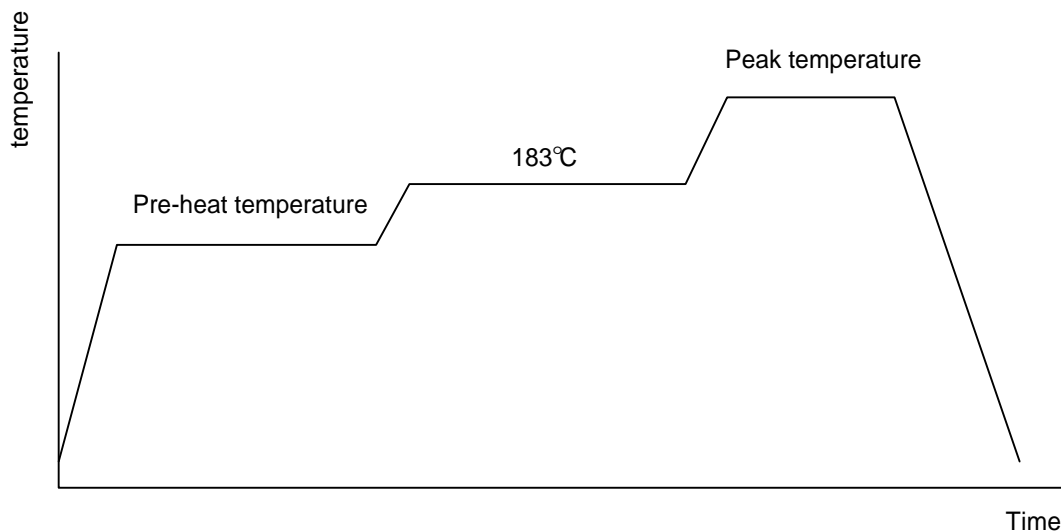

## Classification Reflow Profiles

	Convection or IR/ Convection	VPR
Average ramp-up rate(183°C to Peak)	3°C/second max.	10 °C /second max.
Preheat temperature 125 ± 25°C)	120 seconds max	
Temperature maintained above 183°C	60 – 150 seconds	
Time within 5°C of actual peak temperature	10 –20 seconds	60 seconds
Peak temperature range	220 +5/-0°C or 235 +5/-0°C	215-219°C or 235 +5/-0°C
Ramp-down rate	6 °C /second max.	10 °C /second max.
Time 25°C to peak temperature	6 minutes max.	

## Package Reflow Conditions

pkg. thickness ≥ 2.5mm and all bgas	pkg. thickness < 2.5mm and pkg. volume ≥ 350 mm <sup>3</sup>	pkg. thickness < 2.5mm and pkg. volume < 350mm <sup>3</sup>
Convection 220 +5/-0 °C		Convection 235 +5/-0 °C
VPR 215-219 °C		VPR 235 +5/-0 °C
IR/Convection 220 +5/-0 °C		IR/Convection 235 +5/-0 °C

### Reliability test program

Test item	Method	Description
SOLDERABILITY	MIL-STD-883D-2003	245°C , 5 SEC
HOLT	MIL-STD-883D-1005.7	1000 Hrs Bias @ 125 °C
PCT	JESD-22-B, A102	168 Hrs, 100 % RH , 121°C
TST	MIL-STD-883D-1011.9	-65°C ~ 150°C, 200 Cycles
ESD	MIL-STD-883D-3015.7	VHBM > 2KV, VMM > 200V
Latch-Up	JESD 78	10ms , $I_{tr} > 100mA$

www.DataSheet4U.com

### Carrier Tape

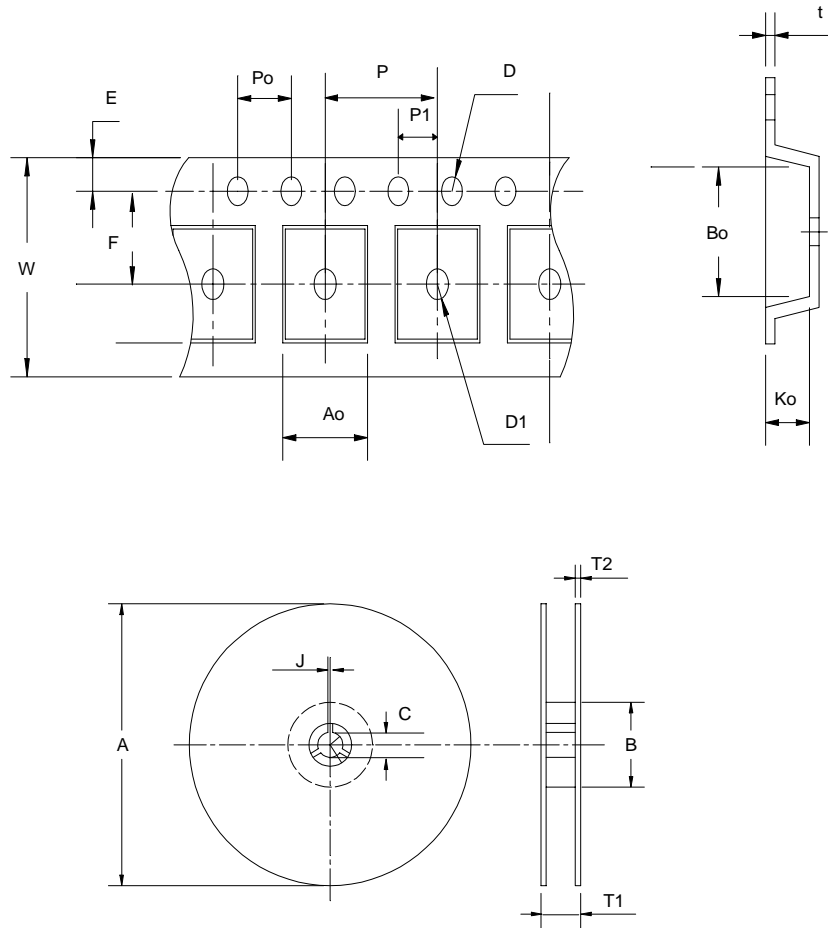

## Reel Dimensions

Application	A	B	C	J	T1	T2	W	P	E
SOP- 8/-P	330 ± 1	62 +1.5	12.75+ 0.15	2 ± 0.5	12.4 ± 0.2	2 ± 0.2	12 ± 0.3	8 ± 0.1	1.75 ± 0.1
	F	D	D1	Po	P1	Ao	Bo	Ko	t
	5.5 ± 1	1.55 +0.1	1.55+ 0.25	4.0 ± 0.1	2.0 ± 0.1	6.4 ± 0.1	5.2 ± 0.1	2.1 ± 0.1	0.3 ± 0.013

## Cover Tape Dimensions

Application	Carrier Width	Cover Tape Width	Devices Per Reel
SOP- 8/-P	12	9.3	2500

## Customer Service

### Anpec Electronics Corp.

Head Office :

5F, No. 2 Li-Hsin Road, SBIP,

Hsin-Chu, Taiwan, R.O.C.

Tel : 886-3-5642000

Fax : 886-3-5642050

Taipei Branch :

7F, No. 137, Lane 235, Pac Chiao Rd.,

Hsin Tien City, Taipei Hsien, Taiwan, R. O. C.

Tel : 886-2-89191368

Fax : 886-2-89191369