

## MiniSmart

- High-side switch
- Short-circuit protection
- Overtemperature protection with hysteresis
- Overload protection
- Overvoltage protection
- Reverse battery protection<sup>1)</sup>
- Switching inductive load
- Clamp of negative output voltage with inductive loads
- Maximum current internally limited

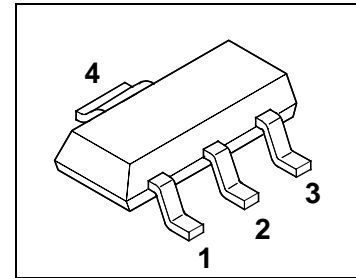

Package: SOT 223

Type	Ordering code
BSP 365	Q67050-M1

Pins:

1	2	3	4
IN	$V_{bb}$	OUT	$V_{bb}$

## Maximum Ratings

Parameter	Symbol	Values	Unit	
Supply voltage	$V_{bb}$	65	V	
Load current self-limited	$I_L$	$I_{L(SC)}$	A	
Maximum current through input pin (DC) see internal circuit diagram	$I_{IN}$	$\pm 15$	mA	
Inductive load switch-off energy dissipation	$E_{AS}$	5	mJ	
Operating temperature range	$T_j$	-40 ... +150	°C	
Storage temperature range	$T_{stg}$	-55 ... +150	°C	
Max. power dissipation (DC) <sup>2)</sup> $T_A = 25\text{ °C}$	$P_{tot}$	1.7	W	
Thermal resistance	chip - soldering point:	$R_{thJS}$	17	K/W
	chip - ambient: <sup>2)</sup>	$R_{thJA}$	72	K/W

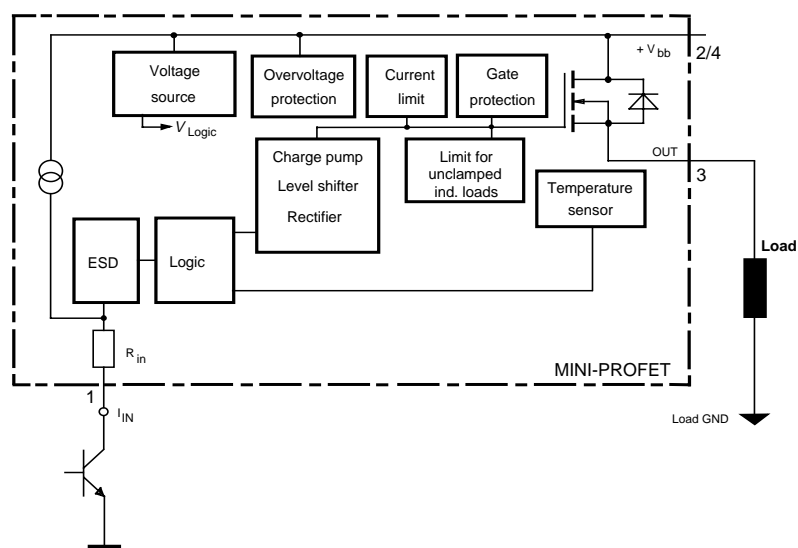

<sup>1)</sup> For 12 V applications only. Reverse load current only limited by connected load.

<sup>2)</sup> BSP 365 on epoxy pcb 40 mm x 40 mm x 1.5 mm with 6 cm<sup>2</sup> copper area for  $V_{bb}$  connection

**Electrical Characteristics**

Parameter and Conditions at $T_j = 25\text{ °C}$ , $V_{bb} = 24\text{ V}$ unless otherwise specified	Symbol	Values			Unit
		min	typ	max	

**Load Switching Capabilities and Characteristics**

On-state resistance (pin 2 to 3) $I_L = 100\text{ mA}$ , pin 1 = GND $T_j = 25\text{ °C}$ $T_j = 150\text{ °C}$ $I_L = 50\text{ mA}$ , $V_{bb} = 4,9\text{ V}$ , $T_j = 25\text{ °C}$	$R_{ON}$	--	4 8 --	5 10 15	$\Omega$
Nominal load current (pin 2 to 3) ISO Standard: $V_{ON} = V_{bb} - V_{OUT} = 0.5\text{ V}$ $T_S = 85\text{ °C}$	$I_{L(ISO)}$	0.07	--	--	A
Turn-on time to 90% $V_{OUT}$	$t_{on}$	--	60	100	$\mu\text{s}$
Turn-off time to 10% $V_{OUT}$ $R_L = 270\ \Omega$	$t_{off}$	--	70	100	$\mu\text{s}$
Slew rate on 10 to 30% $V_{OUT}$ , $R_L = 270\ \Omega$	$dV/dt_{on}$	--	4	6	$\text{V}/\mu\text{s}$
Slew rate off 70 to 40% $V_{OUT}$ , $R_L = 270\ \Omega$	$-dV/dt_{off}$	--	2	6	$\text{V}/\mu\text{s}$

**Input**

OFF state input current $T_j = -40\text{...}+150\text{ °C}$ $R_L = 270\ \Omega$ , $V_{OUT} \leq 0,1\text{ V}$	$I_{IN(off)}$	--	--	0.05	mA
ON state input current, (pin 1 grounded) <sup>3)</sup> $T_j = -40\text{...}+150\text{ °C}$	$I_{IN(on)}$	--	0.35	1	mA

**Operating Parameters**

Operating voltage (pin 1 grounded) <sup>4)</sup> $T_j = -40\text{...}+150\text{ °C}$	$V_{bb(on)}$	4.9	--	60	V
Leakage current (pin 2 to 3, pin 1 open) $T_j = -40\text{...}+150\text{ °C}$ $V_{bb} = 60\text{ V}$ , $T_j = -40\text{...}+150\text{ °C}$	$I_{bb(off)}$	--	1.2 --	10 60	$\mu\text{A}$

<sup>3)</sup> Driver circuit must be capable to drive currents >1mA.

<sup>4)</sup> Below  $V_{bb}=4.5\text{ V}$  typ. without chargepump,  $V_{out} \approx V_{bb} - 2\text{ V}$

Parameter and Conditions at $T_j = 25\text{ °C}$ , $V_{bb} = 24\text{V}$ unless otherwise specified	Symbol	Values			Unit
		min	typ	max	

## Protection Functions

Current limit (pin 2 to 3) <sup>5)</sup>	$T_j = 25\text{ °C}$ $T_j = -40\dots+150\text{ °}$	$I_{L(SC)}$	0.2 0.2	0.5 --	1 1.2	A
Thermal overload trip temperature		$T_{jt}$	150	--	--	°C
Thermal hysteresis		$\Delta T_{jt}$	--	10	--	K
Oversvoltage protection	$T_j = -40\dots+150\text{ °C}$	$V_{bbin(AZ)}$	65	72	--	V
Output clamp (ind. load switch off) at $V_{OUT} = V_{bb} - V_{ON(CL)}$		$V_{ON(CL)}$	--	72	--	V
Inductive load switch-off energy dissipation <sup>6)</sup>		$E_{AS}$	--	--	5	mJ
Reverse battery resistor (pin 1 to 2)		$R_{IN}$	--	1	--	kΩ

## Reverse Diode

Continuous reverse drain current	$T_j = 25\text{ °C}$	$I_S$	--	--	0.2	A
Pulsed reverse drain current	$T_j = 25\text{ °C}$	$I_{SM}$	--	--	0.8	A
Diode forward on voltage $I_F = 0.2\text{ A}$ , $I_{IN} = \leq 0.05\text{ mA}$		$V_{SD}$	--	0.9	1.2	V

<sup>5)</sup> load current limits onset at  $I_L \cdot R_{ON}$  approx. 1V  
short circuit protection: combination of current limit and thermal overload switch off

<sup>6)</sup> while demagnetizing load inductance, dissipated energy is  $E_{AS} = \int (V_{ON(CL)} \cdot i_L(t) dt$ ,  
approx.  $E_{AS} = \frac{1}{2} \cdot L \cdot I_L^2 \cdot \left( \frac{V_{ON(CL)}}{V_{ON(CL)} - V_{bb}} \right)$

Max allowable power dissipation

$P_{tot} = f(T_A, T_{SP})$

$P_{tot}$  [W]

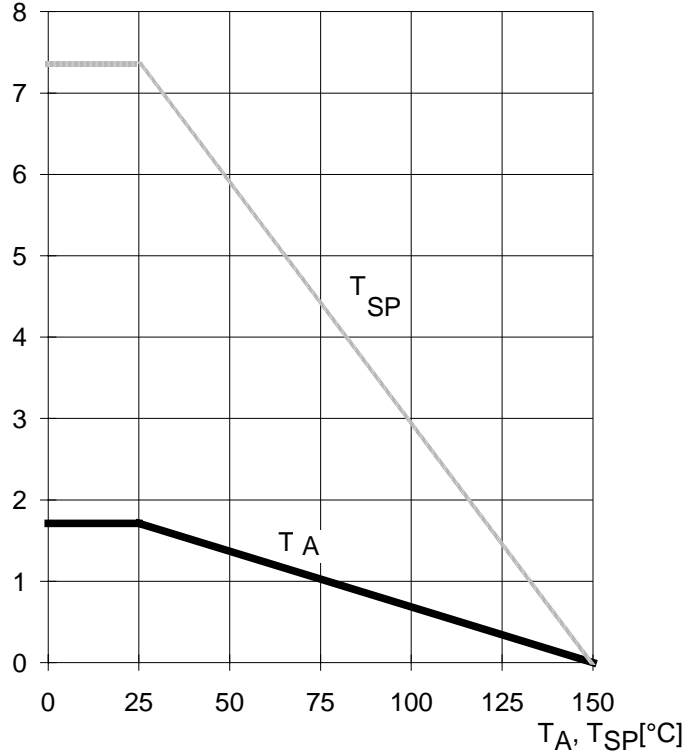

Typ. on state resistance (V<sub>bb</sub>- pin to OUT pin)

$R_{ON} = f(V_{bb}); I_L = 70 \text{ mA}; T_j = 25^\circ\text{C}$

$R_{ON}$  [ $\Omega$ ]

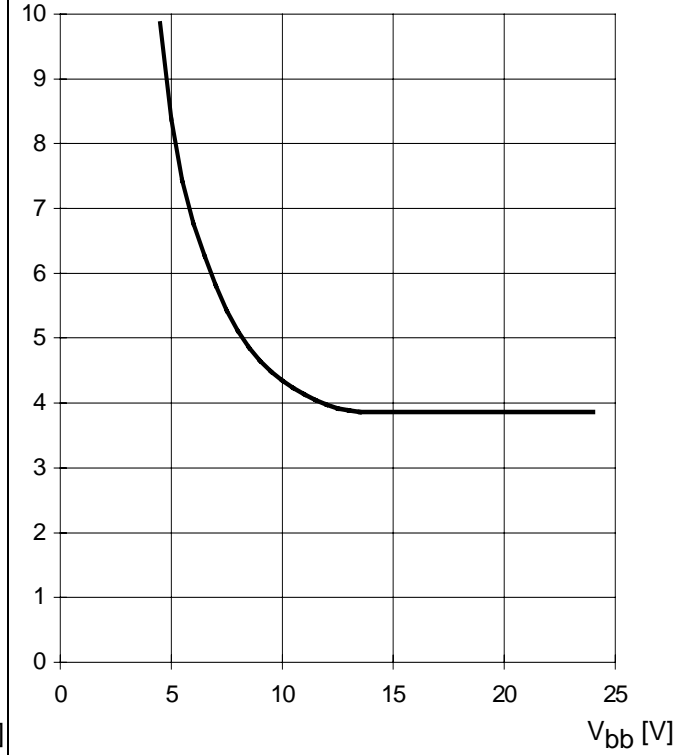

On state resistance (V<sub>bb</sub>- pin to OUT pin)

$R_{ON} = f(T_j); V_{bb} = 13.5 \text{ V}; I_L = 70 \text{ mA}$

$R_{ON}$  [ $\Omega$ ]

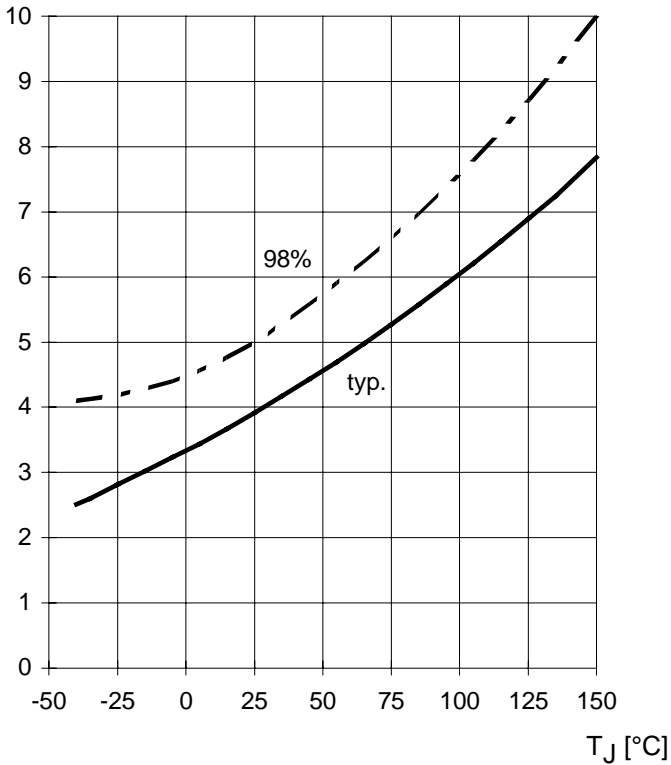

Typ. short circuit current

$I_{L(SC)} = f(T_j); V_{bb} = 13.5 \text{ V}$

$I_{L(SC)}$  [A]

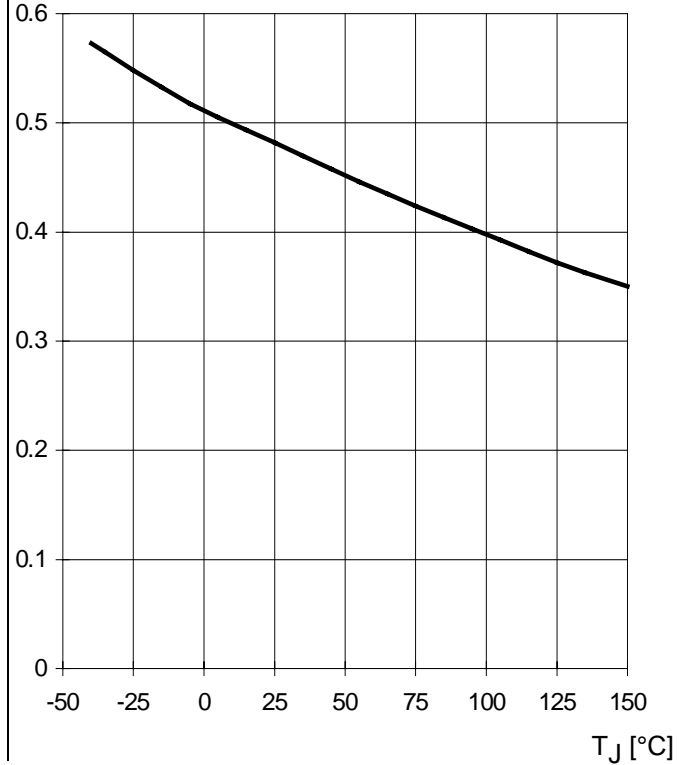

Typ. short circuit current

$I_{L(SC)} = f(V_{ON}); V_{bb} = 13.5V; T_j = 25^\circ C$

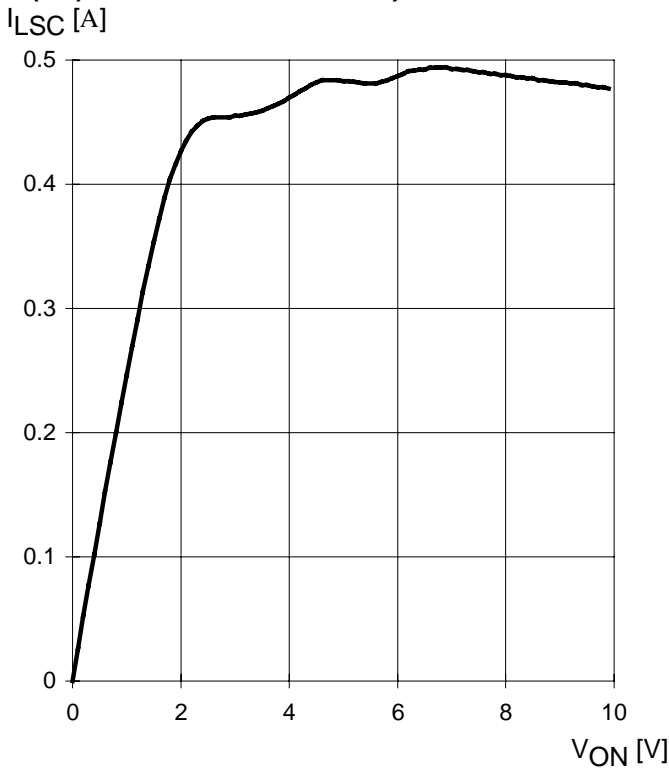

Typ. short circuit current

$I_{L(SC)} = f(t); V_{bb} = 13.5V$   
no heatsink; Parameter: T<sub>jStart</sub>

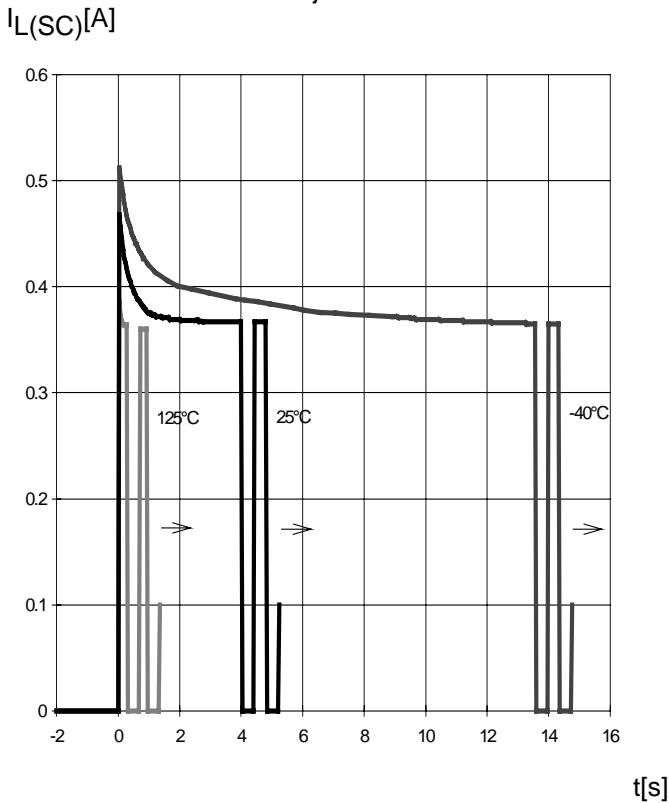

Test circuit

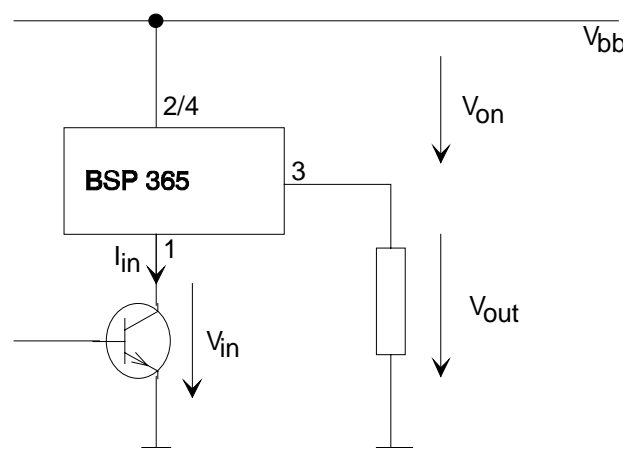

Turn on conditions

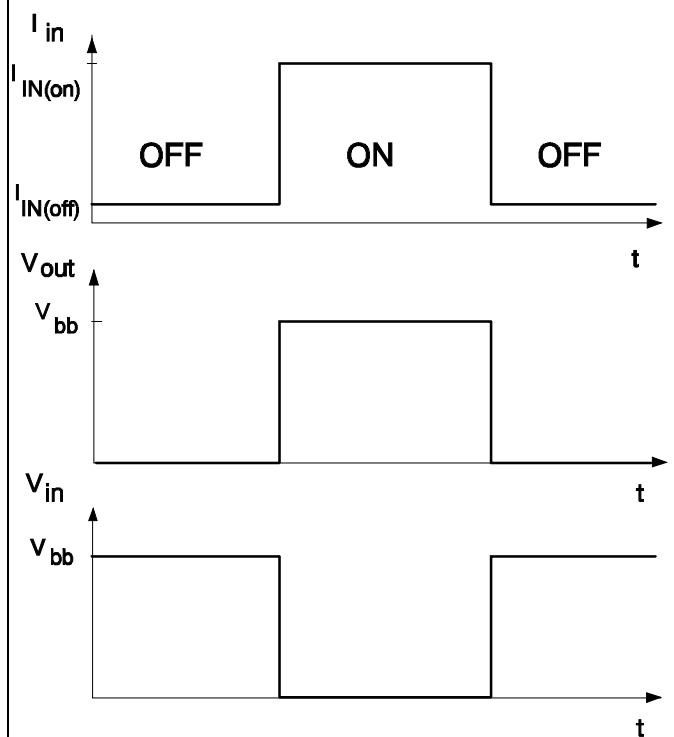

Chargepump threshold

$V_{ON} = f(V_{bb})$

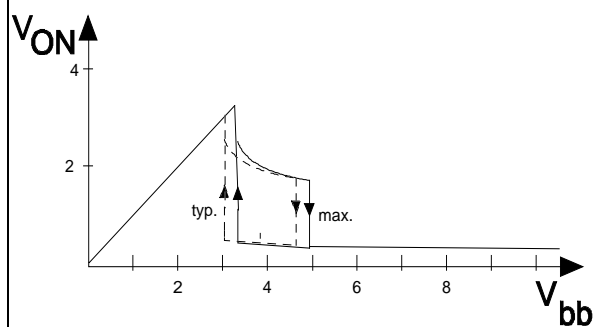

## Package:

all dimensions in mm.

SOT 223/3:

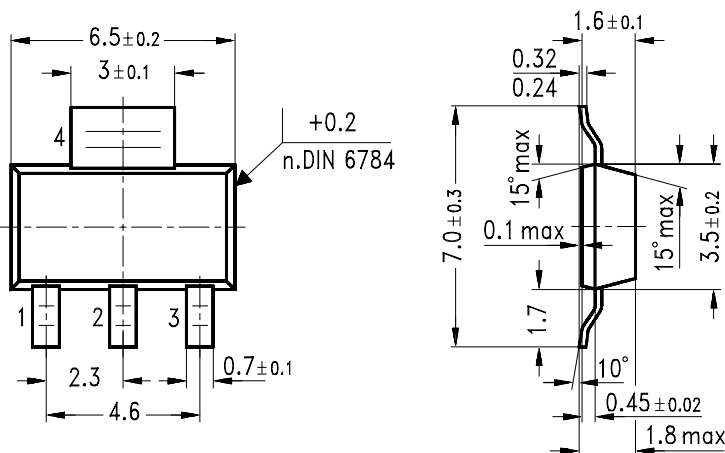

GPS05560

## Edition 7.97

Published by Siemens AG,  
Bereich Halbleiter Vertrieb,  
Werbung, Balanstraße 73,  
81541 München

© Siemens AG 1997  
All Rights Reserved.

### Attention please!

As far as patents or other rights of third parties are concerned, liability is only assumed for components, not for applications, processes and circuits implemented within components or assemblies.

The information describes a type of component and shall not be considered as warranted characteristics.

Terms of delivery and rights to change design reserved.

For questions on technology, delivery and prices please contact the Semiconductor Group Offices in Germany or the Siemens Companies and Representatives worldwide (see address list).

Due to technical requirements components may contain dangerous substances. For information on the types in question please contact your nearest Siemens Office, Semiconductor Group.

Siemens AG is an approved CECC manufacturer.

### Packing

Please use the recycling operators known to you. We can also help you - get in touch with your nearest sales office. By agreement we will take packing material back, if it is sorted. You must bear the costs of transport.

For packing material that is returned to us unsorted or which we are not obliged to accept, we shall have to invoice you for any costs incurred.

### Components used in life-support devices or systems must be expressly authorized for such purpose!

Critical components<sup>1</sup> of the Semiconductor Group of Siemens AG, may only be used in life-support devices or systems<sup>2</sup> with the express written approval of the Semiconductor Group of Siemens AG.

1) A critical component is a component used in a life-support device or system whose failure can reasonably be expected to cause the failure of that life-support device or system, or to affect its safety or effectiveness of that device or system.

2) Life support devices or systems are intended (a) to be implanted in the human body, or (b) to support and/or maintain and sustain and/or protect human life. If they fail, it is reasonable to assume that the health of the user or other persons may be endangered.