

TOSHIBA Bi-CMOS INTEGRATED CIRCUIT SILICON MONOLITHIC

TB6504F/FG

PWM CHOPPER TYPE BIPOLAR STEPPING MOTOR DRIVER

The TB6504F/FG is PWM chopper type sinusoidal micro step bipolar stepping motor driver.

Sinusoidal micro step operation is accomplished only a clock signal inputting by means of built-in hard ware.

FEATURES

- 1 chip bipolar sinusoidal micro step stepping motor driver.
- Output Current up to 150 mA
- PWM chopper type.
- Structured by high voltage Bi-CMOS process technology.
- Forward and reverse rotation are available.
- 2, 1-2, W1-2, 2W1-2 phase 1 or 2 clock drives are selectable.
- Package : SSOP24-P-300-1.00
- Input Pull-Up Resistor equipped with RESET and ENABLE Terminal : R = 200 k Ω (Typ.)
- Output Monitor available with $\overline{M\bar{O}.I\bar{O}(\overline{M\bar{O}})} = \pm 2$ mA MAX.
- Reset and Enable are available with $\overline{R\bar{E}S\bar{E}T}$ and $\overline{E\bar{N}A\bar{B}L\bar{E}}$.

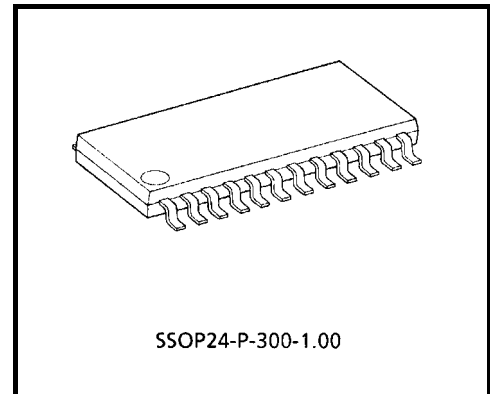

SSOP24-P-300-1.00

Weight : 0.32 g (Typ.)

TB6504FG:

The TB6504FG is a Pb-free product.

The following conditions apply to solderability:

*Solderability

1. Use of Sn-37Pb solder bath
 - *solder bath temperature = 230°C
 - *dipping time = 5 seconds
 - *number of times = once
 - *use of R-type flux
2. Use of Sn-3.0Ag-0.5Cu solder bath
 - *solder bath temperature = 245°C
 - *dipping time = 5 seconds
 - *the number of times = once
 - *use of R-type flux

BLOCK DIAGRAM

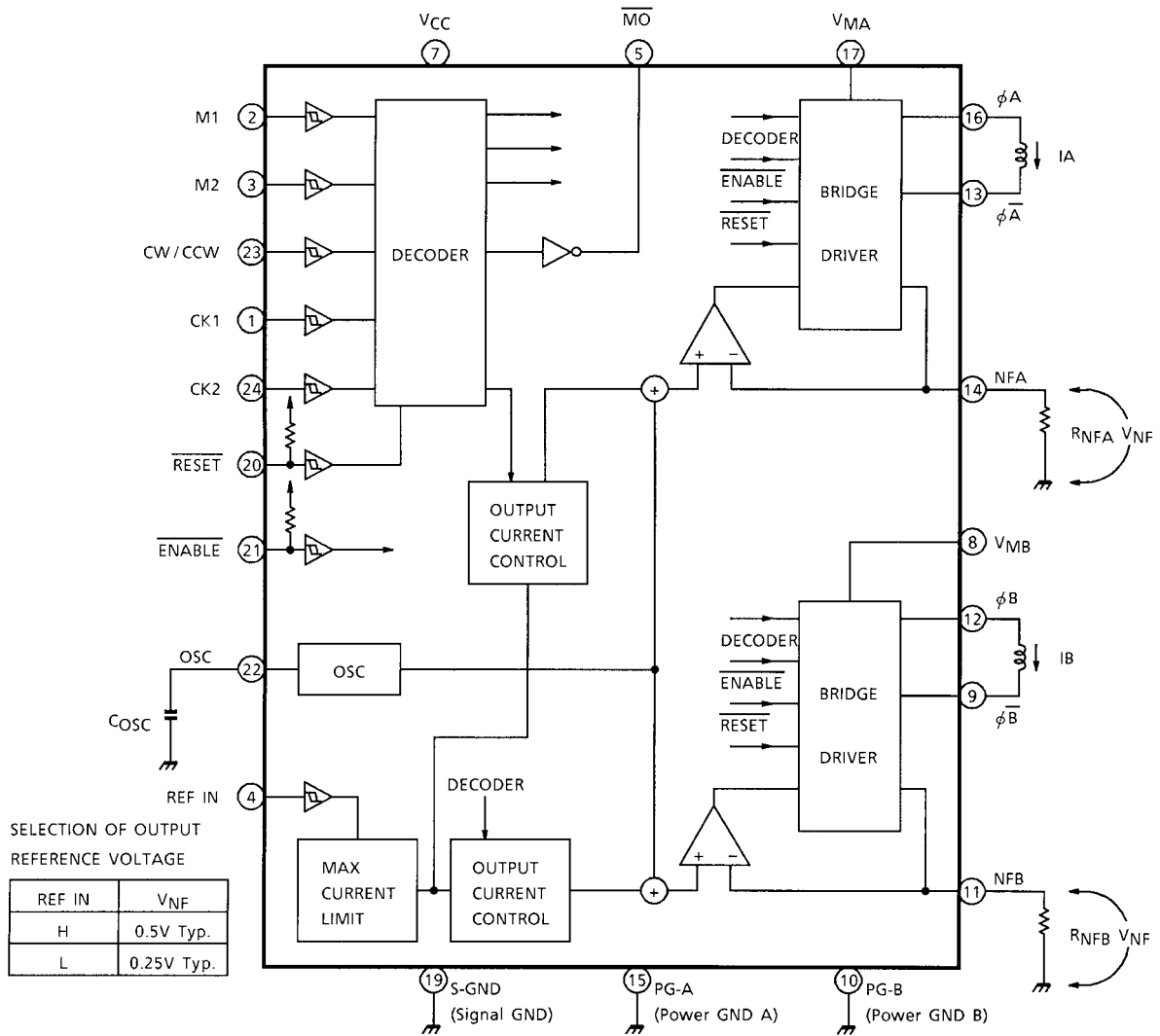

Pull-up Resistance pin (20), (21) : 200 kΩ (Typ.)
 pin (6), (18) : Non Connection

PIN FUNCTION

| PIN No. | SYMBOL | FUNCTIONAL DESCRIPTION | |
|---------|---------------------|---|---------------|
| 1 | CK1 | Clock signal input terminal. | TRUTH TABLE A |
| 2 | M1 | Excitation control input. | TRUTH TABLE B |
| 3 | M2 | Excitation control input. | |
| 4 | REF IN | V_{NF} control input. High Level ; $V_{NF} = 0.5 V$, Low Level ; $V_{NF} = 0.25 V$ | |
| 5 | \overline{MO} | Monitor output. | |
| 6 | NC | No connection. | |
| 7 | VCC | Supply voltage terminal for control circuit. | |
| 8 | V_{MB} | Supply voltage terminal for Motor Drive. | |
| 9 | $\phi\overline{B}$ | Output \overline{B} | |
| 10 | PG-B | Power GND | |
| 11 | NFB | B-ch current detection terminal. | |
| 12 | ϕB | Output B | |
| 13 | $\phi\overline{A}$ | Output \overline{A} | |
| 14 | NFA | A-ch current detection terminal. | |
| 15 | PG-A | Power GND | |
| 16 | ϕA | Output A. | |
| 17 | V_{MA} | Supply voltage terminal for Motor Drive. | |
| 18 | NC | No connection. | |
| 19 | S-GND | Signal GND. | |
| 20 | \overline{RESET} | Reset signal input terminal. | TRUTH TABLE A |
| 21 | \overline{ENABLE} | Enable signal input terminal. | |
| 22 | OSC | Sawtooth oscillation terminal. | |
| 23 | CW / CCW | Forward rotation / Reverse rotation input terminal. | TRUTH TABLE A |
| 24 | CK2 | Clock signal input terminal. | |

PIN CONNECTION (Top view)

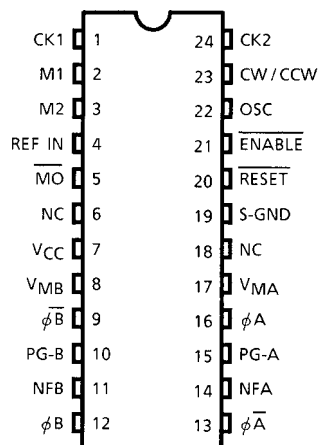

Note: NC : No connection

TRUTH TABLE A

| INPUT | | | | | MODE |
|-------|-----|----------|---------------------------|----------------------------|----------------|
| CK1 | CK2 | CW / CCW | $\overline{\text{RESET}}$ | $\overline{\text{ENABLE}}$ | |
| | H | L | H | L | CW |
| | L | L | H | L | INHIBIT (Note) |
| H | | L | H | L | CCW |
| L | | L | H | L | INHIBIT (Note) |
| | H | H | H | L | CCW |
| | L | H | H | L | INHIBIT (Note) |
| H | | H | H | L | CW |
| L | | H | H | L | INHIBIT (Note) |
| X | X | X | L | L | INITIAL |
| X | X | X | X | H | Z |

Z : High impedance
 X : Don't care
 Note: Please don't use INHIBIT mode.

TRUTH TABLE B

| INPUT | | MODE (EXCITATION) |
|-------|----|----------------------|
| M1 | M2 | |
| L | L | 2 Phase |
| H | L | 1-2 Phase |
| L | H | W1-2 Phase |
| H | H | 2W1-2 Phase |

INITIAL MODE

| MODE | I _{OUT} (A) | I _{OUT} (B) |
|-------------|----------------------|----------------------|
| 2 Phase | 100% | -100% |
| 1-2 Phase | 100% | 0% |
| W1-2 Phase | 100% | 0% |
| 2W1-2 Phase | 100% | 0% |

EXCITATION

2 Phase excitation (M1 : L, M2 : L, CW MODE)

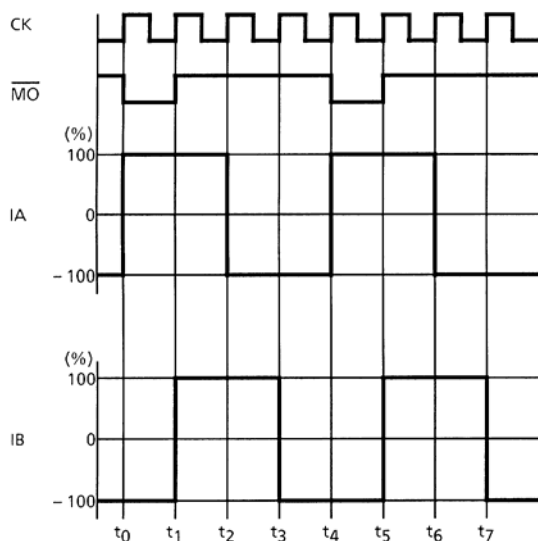

1-2 Phase excitation (M1 : H, M2 : L, CW MODE)

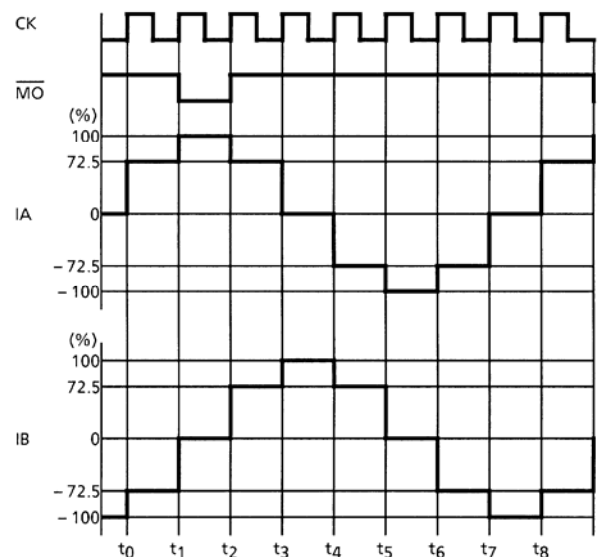

W1-2 Phase excitation (M1 : L, M2 : H, CW MODE)

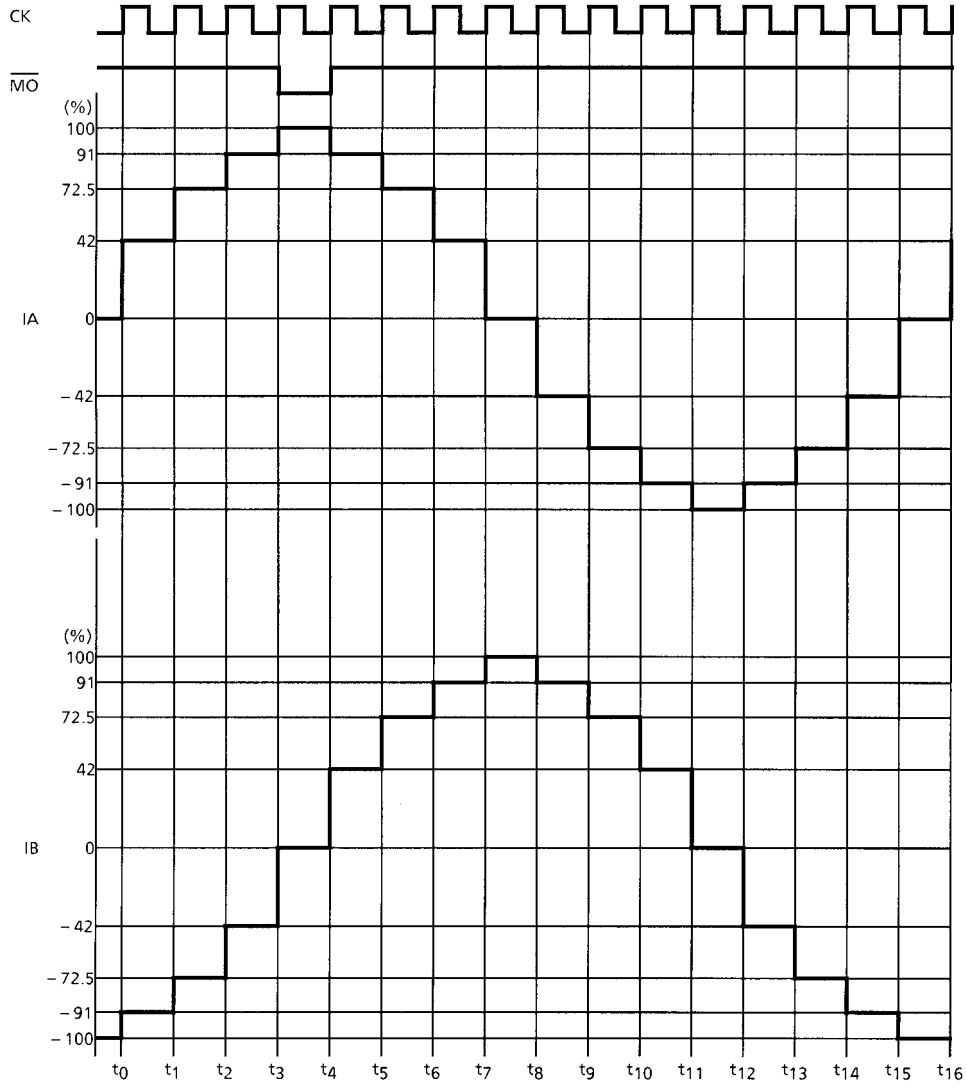

2W1-2 Phase excitation (M1 : H, M2 : H, CW MODE)

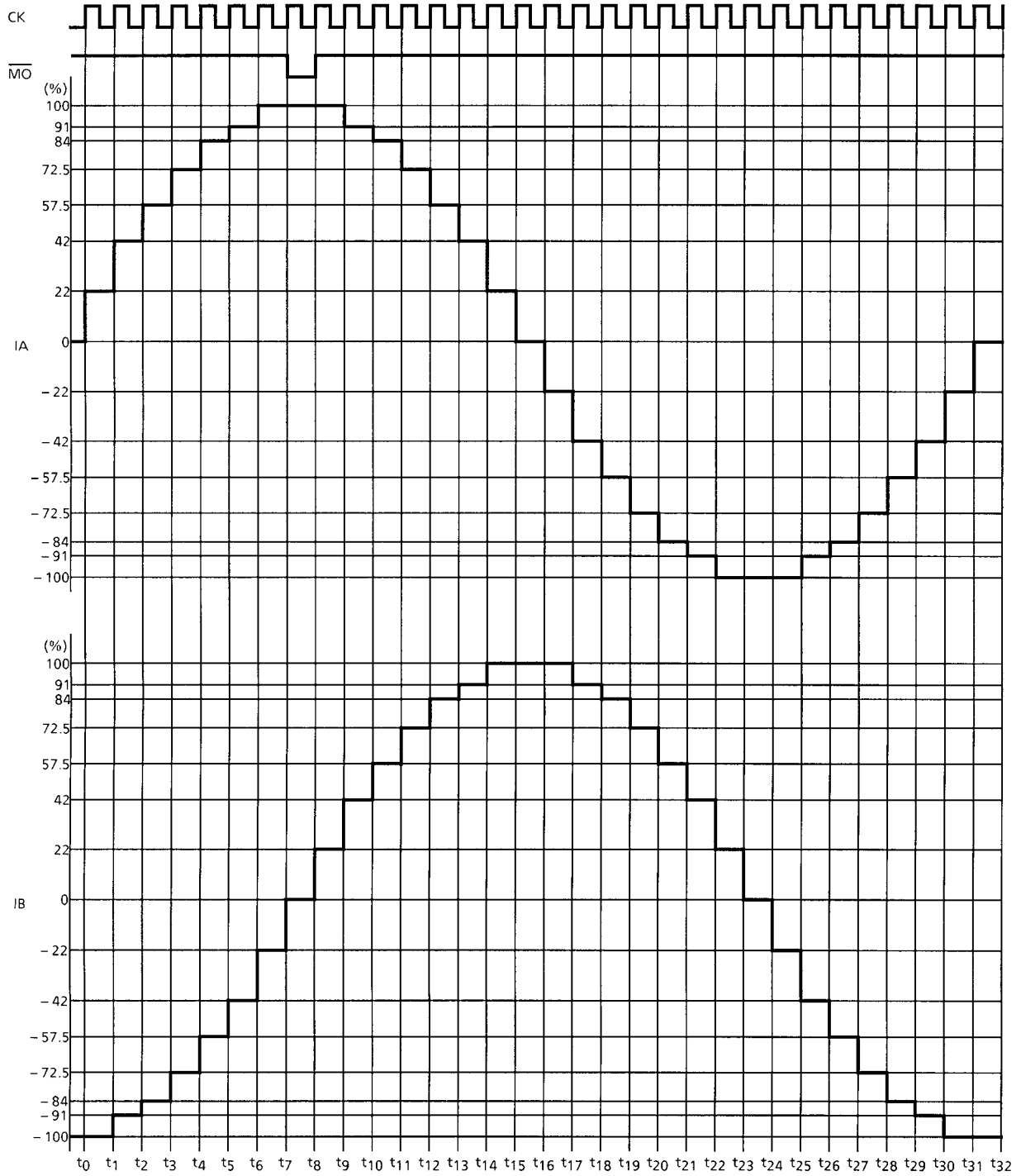

OUTPUT CURRENT VECTOR ORBIT (Normalize to 90° for each one step)

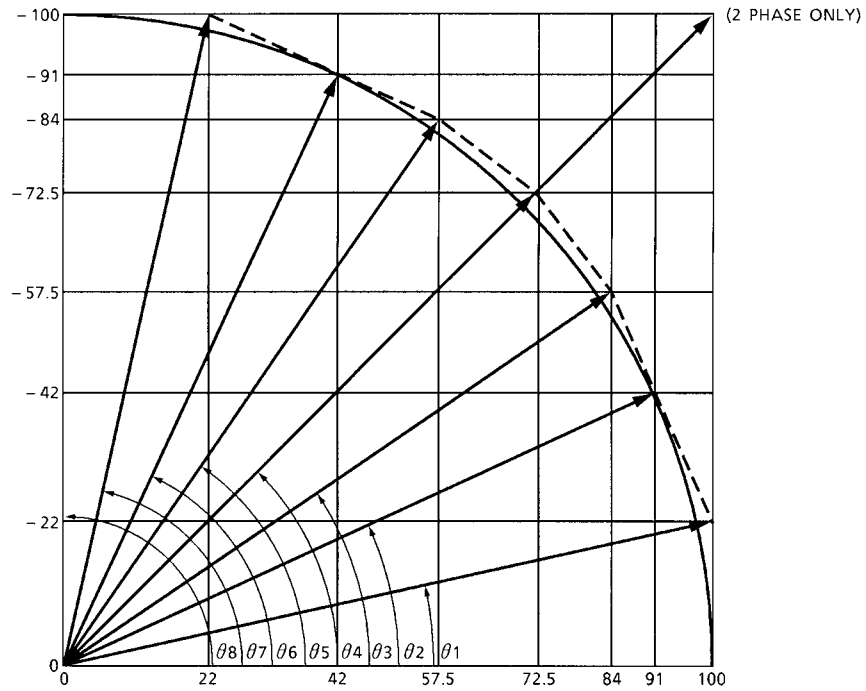

| θ | ROTATION ANGLE | | VECTOR LENGTH | | |
|------------|----------------|------------|---------------|-------------------------|---------|
| | IDEAL | TB6504F/FG | IDEAL | TB6504F/FG | |
| θ_0 | 0° | 0° | 100 | 100.00 | — |
| θ_1 | 11.25° | 12.41° | 100 | 102.39 | — |
| θ_2 | 22.5° | 27.78° | 100 | 100.22 | — |
| θ_3 | 33.75° | 34.39° | 100 | 101.80 | — |
| θ_4 | 45° | 45° | 100 | 102.53 | 141.42 |
| θ_5 | 56.25° | 55.61° | 100 | 101.81 | — |
| θ_6 | 67.5° | 65.22° | 100 | 100.22 | — |
| θ_7 | 78.75° | 77.59° | 100 | 102.39 | — |
| θ_8 | 90° | 90° | 100 | 100.00 | — |
| | | | | 1-2, W1-2, 2W1-2, Phase | 2 Phase |

OUTPUT CIRCUIT

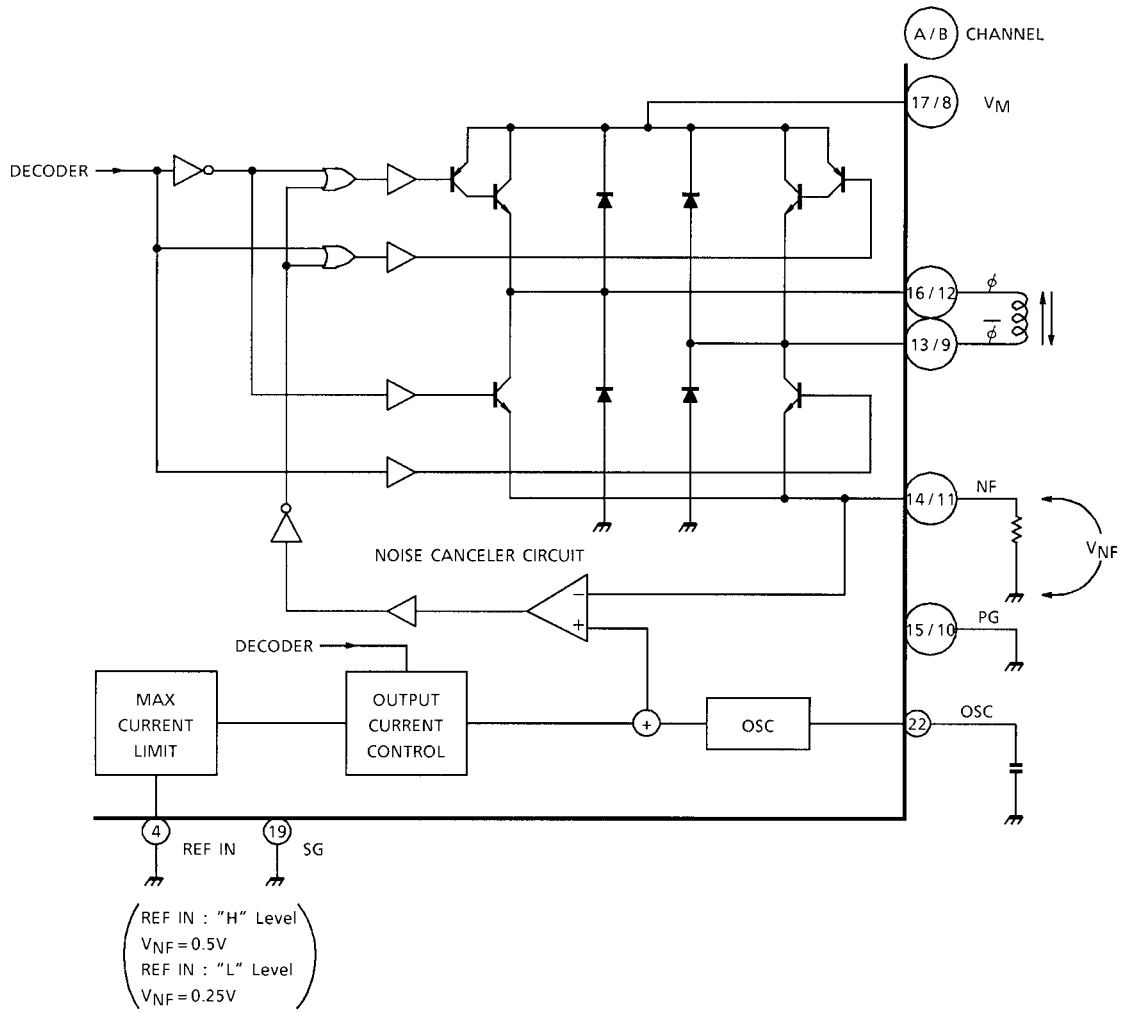

INPUT CIRCUIT

CK1, CK2, CW / CCW, M1, M2, REF IN : Terminals

\overline{RESET} , \overline{ENABLE} : Terminal

OSC : Terminal

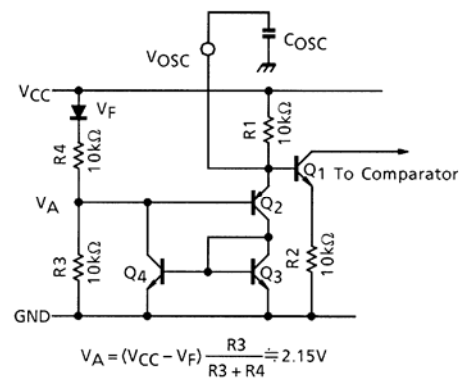
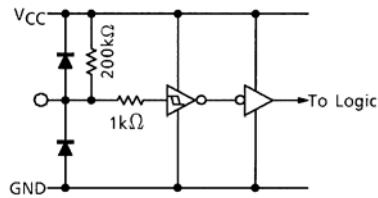
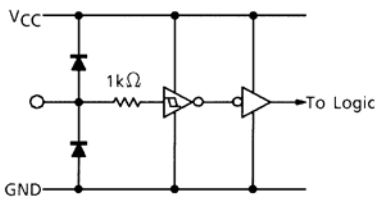

OSC FREQUENCY CALCULATION

Sawtooth OSC circuit consists of Q₁ through Q₄ and R1 through R4.

Q₂ is turned “off” when V_{OSC} is less than the voltage of 2.5 V + V_{BE} Q₂ approximately equal to 2.85 V.

V_{OSC} is increased by C_{OSC} charging through R1.

Q₃ and Q₄ are turned “on” when V_{OSC} becomes 2.85 V (Higher level.)

Lower level of V (22) pin is equal to V_{BE} Q₂ + V_{SAT} Q₄ approximately equal to 1.4 V.

V_{OSC} is calculated by following equation.

$$V_{OSC} = 5 \times [1 - \exp(-\frac{t}{C_{OSC} \times R1})] \dots\dots\dots (1)$$

Assuming that V_{OSC} = 1.4 V (t = t₁) and = 2.85 V (t = t₂)

C_{OSC} is external capacitance connected to pin (22) and R1 is on-chip 10 kΩ resistor.

Therefore, OSC frequency is calculated as follows.

$$t_1 = -C_{OSC} \times R1 \times \ln (1 - \frac{1.4}{5}) \dots\dots\dots (2)$$

$$t_2 = -C_{OSC} \times R1 \times \ln (1 - \frac{2.85}{5}) \dots\dots\dots (3)$$

$$f_{OSC} = \frac{1}{t_2 - t_1} = \frac{1}{C_{OSC} (R1 \times \ln (1 - \frac{1.4}{5}) - R1 \times \ln (1 - \frac{2.85}{5}))}$$

$$= \frac{1}{5.15 \times C_{OSC}} \text{ (kHz) (C}_{OSC} : \mu\text{F)}$$

ENABLE AND RESET FUNCTION AND $\overline{M0}$ SIGNAL

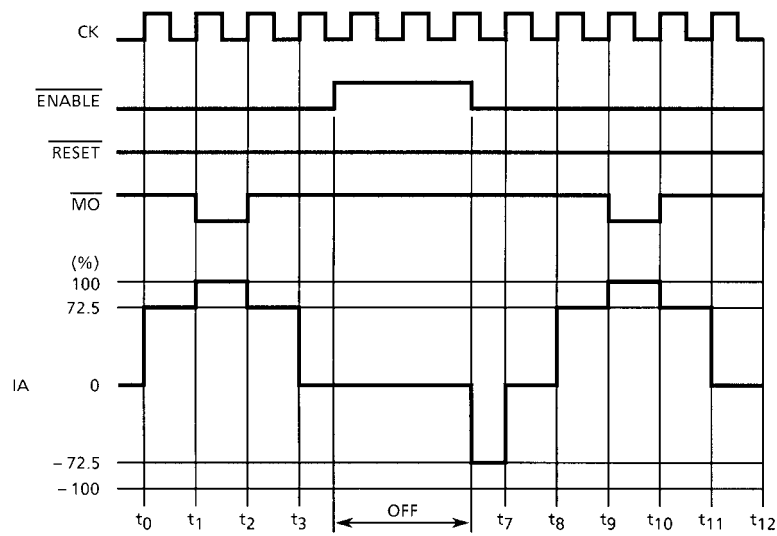

Fig.1 1-2 Phase drive mode (M1 : H, M2 : L)

\overline{ENABLE} Signal disables only Output Signal.

Internal logic functions are proceeded by CK signal without regard to \overline{ENABLE} signal.

Therefore, Output Current is initiated from the proceeded timing point of internal logic circuit after release of disable mode.

Fig.1 shows the \overline{ENABLE} functions, when the system is selected in 1-2 Phase drive mode.

As \overline{RESET} is low, the decoder is initialized and $\overline{M0}$ is low.

After \overline{RESET} is high, the motion is resumed from next clock as shown in Fig.2.

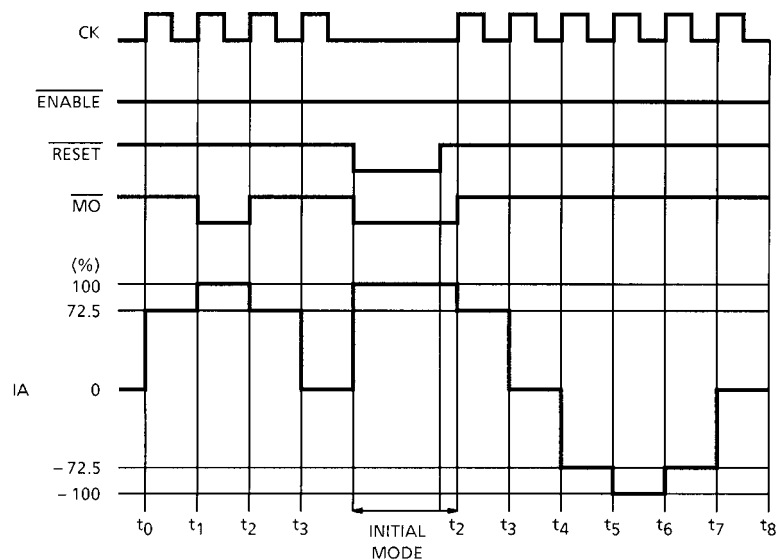

Fig.2 1-2 Phase drive mode (M1 : H, M2 : L)

$\overline{M0}$ (Monitor Output) Signals is used as rotation and initial signal for stable rotation checking.

ABSOLUTE MAXIMUM RATINGS (Ta = 25°C)

| CHARACTERISTIC | SYMBOL | RATING | UNIT |
|-----------------------|----------------------|--------------------------|------|
| Supply Voltage | V _{CC} | 5.5 | V |
| | V _{M (opr)} | V _{CC} - 0.3~10 | |
| | V _{M (MAX)} | 18 | |
| Output Current | I _{O (MAX)} | 150 | mA |
| | I _{O (MO)} | ±2 | |
| Input Voltage | V _{IN} | ~V _{CC} | V |
| Power Dissipation | P _D | 0.59 (Note 1) | W |
| | | 0.83 (Note 2) | |
| Operating Temperature | T _{opr} | -10~70 | °C |
| Storage Temperature | T _{stg} | -55~150 | °C |
| Feed Back Voltage | V _I | 1.0 | V |

Note 1: No heat sink

Note 2: With heat sink (50 × 50 × 1.6 mm Cu 10%)

RECOMMENDED OPERATING CONDITIONS (Ta = -10~70°C)

| CHARACTERISTIC | SYMBOL | TEST CIRCUIT | TEST CONDITION | MIN | TYP. | MAX | UNIT |
|-----------------|-----------------------|--------------|----------------|-----|------|-----------------|------|
| Supply Voltage | V _{CC (opr)} | — | — | 4.5 | 5.0 | 5.5 | V |
| Output Voltage | V _{M (opr)} | — | — | 5.5 | — | 8.0 | V |
| Output Current | I _{OUT} | — | — | — | — | 120 | mA |
| Input Voltage | V _{IN} | — | — | — | — | V _{CC} | V |
| Clock Frequency | f _{CLOCK} | — | — | — | — | 5 | kHz |
| OSC Frequency | f _{OSC} | — | — | 15 | — | 80 | kHz |

ELECTRICAL CHARACTERISTICS

(Unless otherwise specified, Ta = 25°C, VCC = 5 V, VM = 8 V)

| CHARACTERISTIC | | SYMBOL | TEST CIRCUIT | TEST CONDITION | MIN | TYP. | MAX | UNIT |
|---|------|-------------------------|--------------|--|-------------|------|-------------------------|------|
| Input Voltage | High | V _{IN (H)} | 1 | M1, M2, CW / CCW, REF IN ENABLE, CK1, CK2, RESET | 3.5 | — | V _{CC} +0.4 | V |
| | Low | V _{IN (L)} | | | GND -0.4 | — | 1.5 | |
| Input Hysteresis Voltage | | V _H | | | — | 600 | — | mV |
| Input Current | | I _{IN-1 (H)} | 1 | M1, M2, REF IN, V _{IN} = 5.0 V | — | — | 100 | nA |
| | | I _{IN-1 (L)} | | ENABLE, V _{IN} = 0 V, RESET INTERNAL PULL-UP RESISTOR | 5 | 25 | 50 | μA |
| | | I _{IN-2 (L)} | | SOURCE TYPE, V _{IN} = 0 V | — | — | 100 | nA |
| Quiescent Current V _{CC} Terminal | | I _{CC1} | 2 | Output Open RESET : H ENABLE : L (2, 1-2 Phase excitation) | — | 10 | 18 | mA |
| | | I _{CC2} | | Output Open (W1-2, 2W1-2 Phase excitation) RESET : H ENABLE : L | — | 10 | 18 | |
| | | I _{CC3} | | RESET : L, ENABLE : H | — | 5 | — | |
| | | I _{CC4} | | RESET : H, ENABLE : H | — | 5 | — | |
| Comparator Reference Voltage | High | V _{NF (H)} | 3 | REF IN H R _{NF} = 5 Ω, C _{OSC} = 0.0033 μF | 0.45 | 0.5 | 0.55 | V |
| | Low | V _{NF (L)} | | REF IN L R _{NF} = 2.5 Ω, C _{OSC} = 0.0033 μF | 0.22 | 0.25 | 0.28 | |
| Output Differential | | ΔV _O | — | B / A, C _{OSC} = 0.0033 μF R _{NF} = 2.5 Ω, REF IN = L | -10 | — | 10 | % |
| V _{NP (H)} -V _{NF (L)} | | ΔV _{NF} | — | V _{NF (L)} / V _{NF (H)} C _{OSC} = 0.0033 μF | 43 | 50 | 57 | % |
| Maximum OSC Frequency | | f _{OSC (MAX.)} | — | — | 100 | — | — | kHz |
| Minimum OSC Frequency | | f _{OSC (MIN.)} | — | — | — | — | 10 | kHz |
| OSC Frequency | | f _{OSC} | — | C _{OSC} = 0.0033 μF | 31 | 44 | 70 | kHz |
| Output Voltage | | V _{OH (MO)} | — | I _{OH} = -40 μA | 4.5 | 4.9 | V _{CC} | V |
| | | V _{OL (MO)} | — | I _{OL} = 40 μA | GND | 0.1 | 0.5 | |

OUTPUT BLOCK

| CHARACTERISTIC | | | | SYMBOL | TEST CIRCUIT | TEST CONDITION | MIN | TYP. | MAX | UNIT | |
|--------------------------------------|--------------------------------|-------------|------------|--------------|--------------|--|---|------|------|---------|----|
| Output Saturation Voltage | Upper Side | | | $V_{SAT U1}$ | 4 | $I_{OUT} = 0.12 A$ | — | 0.90 | 1.25 | V | |
| | Lower Side | | | $V_{SAT L1}$ | | | — | 0.22 | 0.37 | | |
| | Upper Side | | | $V_{SAT U2}$ | | $I_{OUT} = 0.06 A$ | — | 0.83 | — | | |
| | Lower Side | | | $V_{SAT L2}$ | | | — | 0.12 | — | | |
| Diode Forward Voltage | Upper Side | | | $V_F U1$ | 5 | $I_{OUT} = 0.12 A$ | — | 1.18 | 1.8 | V | |
| | Lower Side | | | $V_F L1$ | | | — | 0.92 | 1.6 | | |
| Output Dark Current (A + B Channels) | | | | I_{M1} | 2 | \overline{ENABLE} : "H" Level \overline{RESET} : "L" Level Output Open | — | — | 50 | μA | |
| | | | | I_{M2} | | \overline{ENABLE} : "L" Level \overline{RESET} : "H" Level Output Open, 2 Phase excitation mode | — | 8 | 28 | | mA |
| NF Terminal Current | | | | I_{NF} | | \overline{ENABLE} : "L" Level \overline{RESET} : "H" Level Output Open | 1 | 2.5 | 7 | | |
| A-B Chopping Current (Note) | 2W1-2 ϕ | W1-2 ϕ | 1-2 ϕ | VECTOR | 3 | $\theta = 0$ | REF IN : L RNF = 2.5 Ω C _{OSC} = 0.0033 μF L = 10 mH/R = 0.5 Ω | — | 100 | — | % |
| | 2W1-2 ϕ | — | — | | | $\theta = 1 / 8$ | | — | 100 | — | |
| | 2W1-2 ϕ | W1-2 ϕ | — | | | $\theta = 2 / 8$ | | 86 | 91 | 96 | |
| | 2W1-2 ϕ | — | — | | | $\theta = 3 / 8$ | | 79 | 84 | 89 | |
| | 2W1-2 ϕ | W1-2 ϕ | 1-2 ϕ | | | $\theta = 4 / 8$ | | 67.5 | 72.5 | 77.5 | |
| | 2W1-2 ϕ | — | — | | | $\theta = 5 / 8$ | | 52.5 | 57.5 | 62.5 | |
| | 2W1-2 ϕ | W1-2 ϕ | — | | | $\theta = 6 / 8$ | | 37 | 42 | 47 | |
| | 2W1-2 ϕ | — | — | | | $\theta = 7 / 8$ | | 17 | 22 | 27 | |
| | 2 Phase Excitation Mode VECTOR | | | | — | — | — | — | 100 | — | |

Note: Maximum current ($\theta = 0$) : 100%
 2W1-2 ϕ : 2W1, 2 phase excitation mode
 W1-2 ϕ : W1, 2 phase excitation mode
 1-2 ϕ : 1, 2 phase excitation mode

| CHARACTERISTIC | | | SYMBOL | TEST CIRCUIT | TEST CONDITION | MIN | TYP. | MAX | UNIT | | |
|-------------------------------------|--------------------------------|-----------------|------------------|-----------------------|---|---|-----------|-------|-------|----|---|
| A-B Chopping Current (Note) | 2W1-2φ | W1-2φ | 1-2φ | VECTOR | 3 | REF IN : L RNF = 3.3 Ω COSC = 0.0033 μF L = 20 mH/R = 60 Ω | θ = 0 | — | 100 | — | % |
| | 2W1-2φ | — | — | | | | θ = 1 / 8 | — | 100 | — | |
| | 2W1-2φ | W1-2φ | — | | | | θ = 2 / 8 | — | 91.2 | — | |
| | 2W1-2φ | — | — | | | | θ = 3 / 8 | — | 84.2 | — | |
| | 2W1-2φ | W1-2φ | 1-2φ | | | | θ = 4 / 8 | — | 73.6 | — | |
| | 2W1-2φ | — | — | | | | θ = 5 / 8 | — | 59 | — | |
| | 2W1-2φ | W1-2φ | — | | | | θ = 6 / 8 | — | 44.6 | — | |
| | 2W1-2φ | — | — | | | | θ = 7 / 8 | — | 25.6 | — | |
| | 2 Phase Excitation Mode VECTOR | | | | | | | — | 100 | — | |
| Feed Back Voltage Step | | | ΔV _{NF} | — | REF IN : L RNF = 2.5 Ω COSC = 0.0033 μF | Δθ = 0 / 8-1 / 8 | — | 0 | — | mV | |
| | | | | | | Δθ = 1 / 8-2 / 8 | 10 | 22.5 | 35 | | |
| | | | | | | Δθ = 2 / 8-3 / 8 | 5 | 17.5 | 30 | | |
| | | | | | | Δθ = 3 / 8-4 / 8 | 16.25 | 28.75 | 41.25 | | |
| | | | | | | Δθ = 4 / 8-5 / 8 | 25 | 37.5 | 50 | | |
| | | | | | | Δθ = 5 / 8-6 / 8 | 26.25 | 38.75 | 51.25 | | |
| | | | | | | Δθ = 6 / 8-7 / 8 | 37.5 | 50 | 62.5 | | |
| Output Tr Switching Characteristics | | | t _r | 7 | R _L = 2 Ω, V _{NF} = 0 V, C _L = 15 pF | — | 0.3 | — | μs | | |
| | | | t _f | | | — | 2.2 | — | | | |
| | | | t _{pLH} | | | CK ~ Output | — | 1.5 | | — | |
| | | | t _{pHL} | | | | — | 2.7 | | — | |
| | | | t _{pLH} | | | OSC ~ Output | — | 5.4 | | — | |
| | | | t _{pHL} | | | | — | 6.3 | | — | |
| | | | t _{pLH} | | | RESET ~ Output | — | 2.0 | | — | |
| | | | t _{pHL} | | | | — | 2.5 | | — | |
| | | | t _{pLH} | | | ENABLE ~ Output | — | 5.0 | | — | |
| | | | t _{pHL} | | | | — | 6.0 | | — | |
| Output Leakage Current | Upper Side | I _{OH} | 6 | V _M = 18 V | — | — | 50 | μA | | | |
| | Upper Side | I _{OL} | | | — | — | 50 | | | | |

Note: Maximum current (θ = 0) : 100%
 2W1-2φ : 2W1, 2 phase excitation mode
 W1-2φ : W1, 2 phase excitation mode
 1-2φ : 1, 2 phase excitation mode

TEST CIRCUIT 1. : V_{IN} (H), (L), I_{IN} (H), (L)

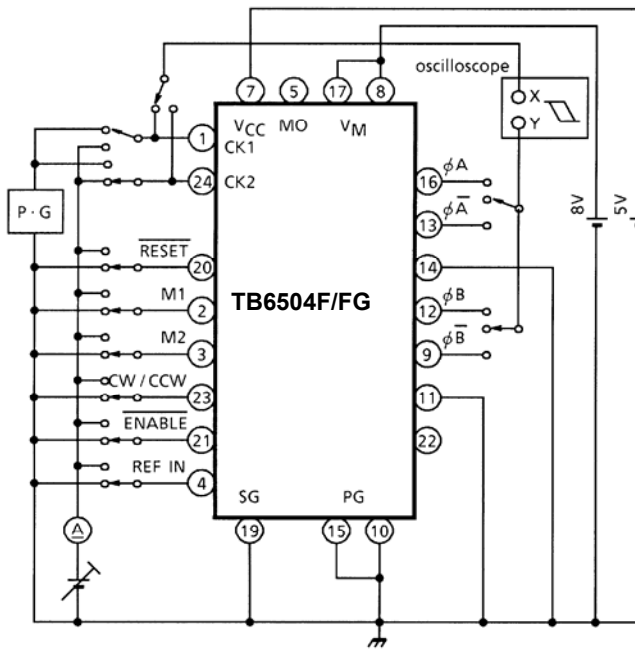

TEST CIRCUIT 2. : I_{CC} , I_M , I_{NF}

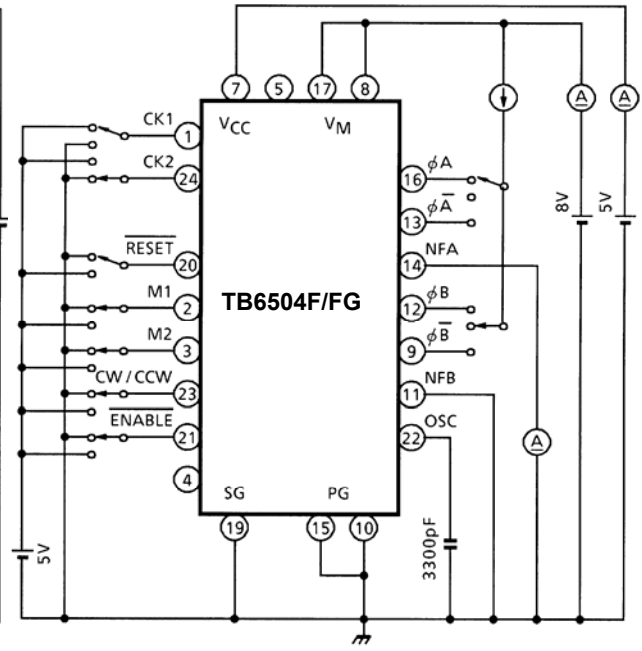

TEST CIRCUIT 3. : V_{NF} (H), (L)

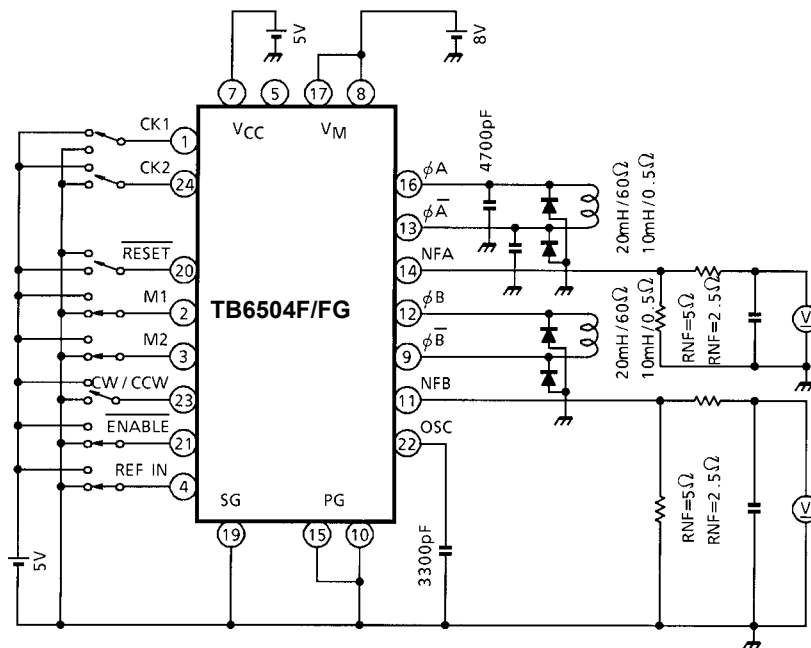

TEST CIRCUIT 4. : $V_{CE(SAT)}$ Upper, Lower

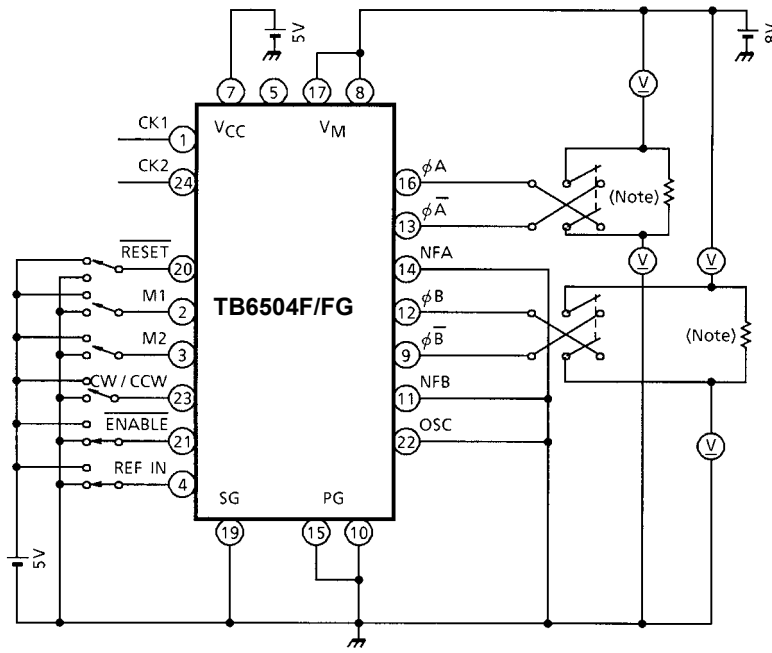

Note: Calibrate Output Current becomes 0.06 A (or 0.12 A) with this resistor.

TEST CIRCUIT 5. : V_{F-U} , V_{F-L}

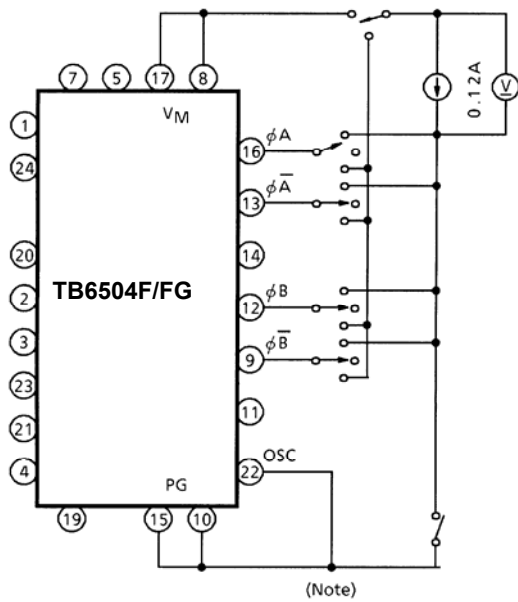

TEST CIRCUIT 6. : I_{OH} , I_{OL}

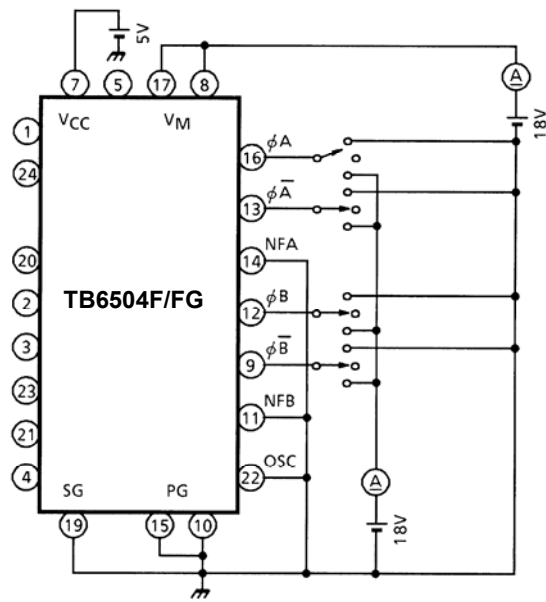

Note: Not to take a GND with any non-connecting Pins.

AC ELECTRICAL CHARACTERISTIC, TEST CIRCUIT

CK (OSC)-OUT

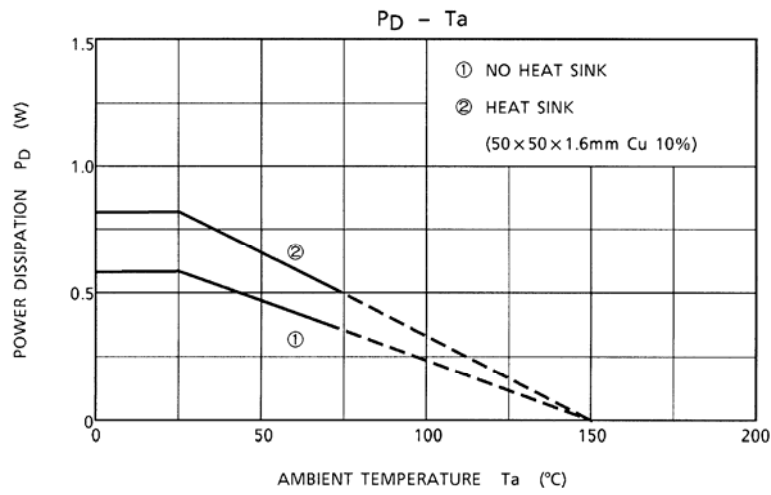
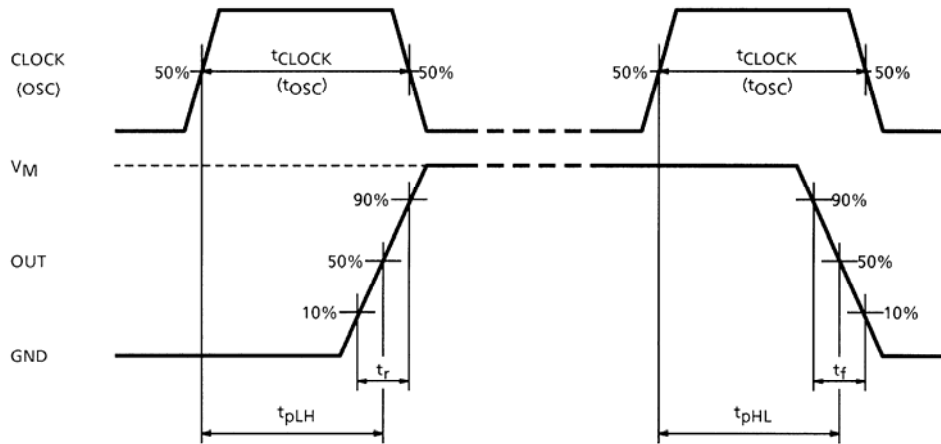

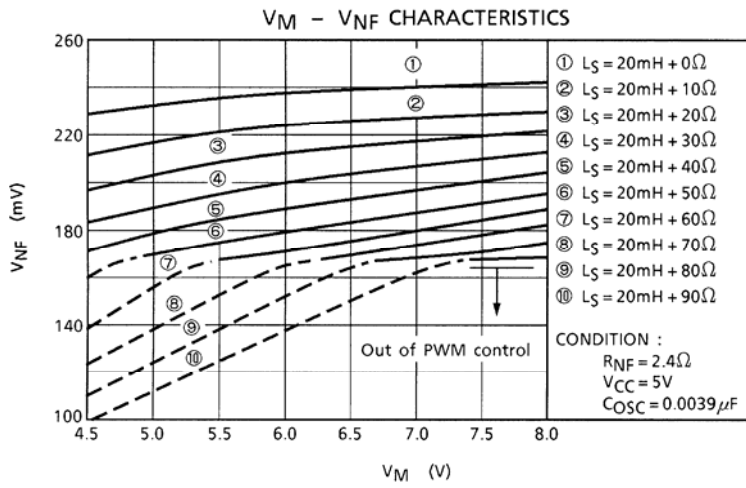
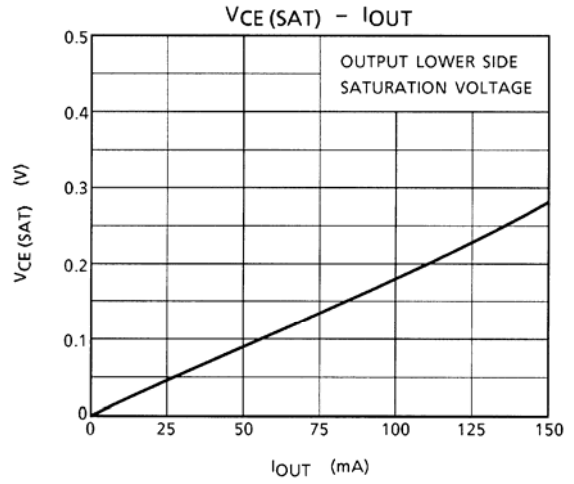
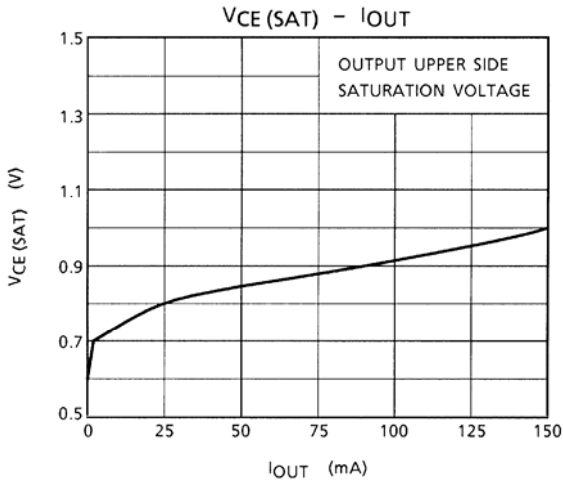

APPLICATION CIRCUIT

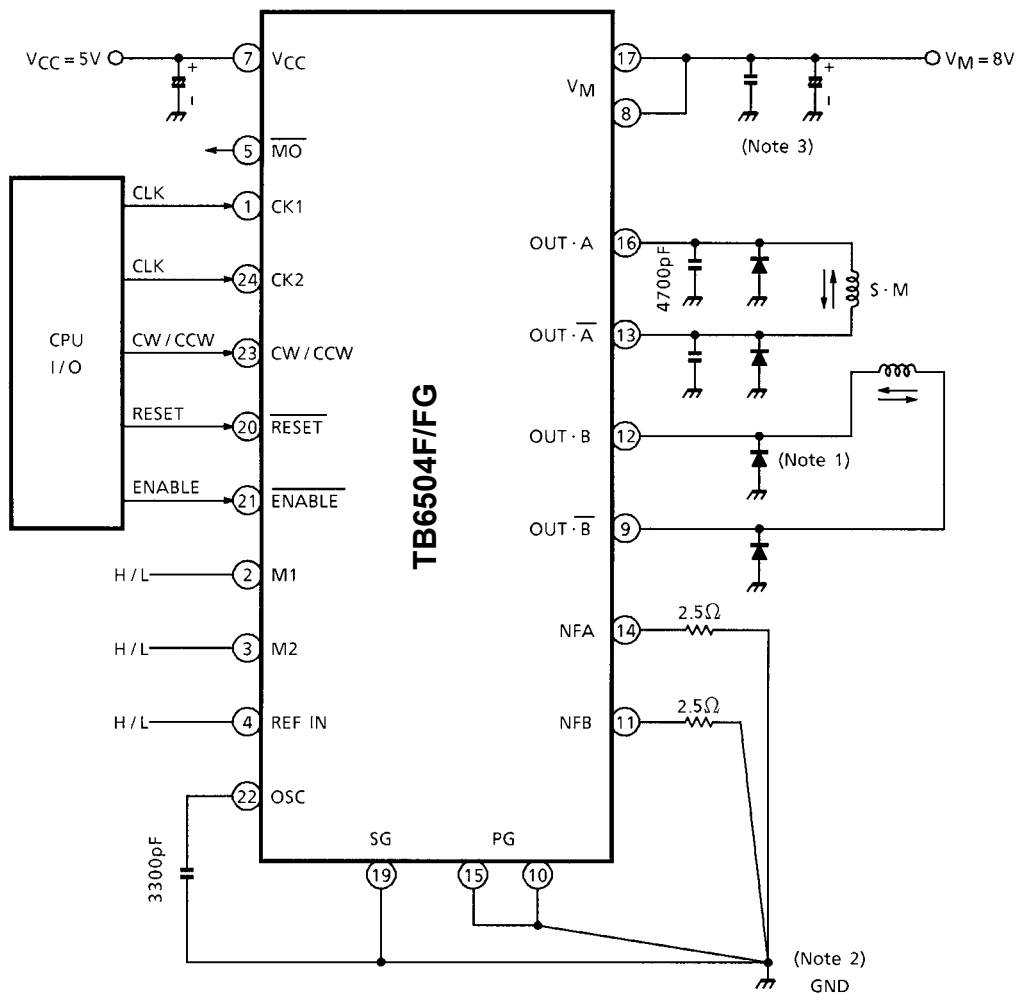

Note 1: Schottky diode (U1GWJ49) to be connected additionally between each output (pin 16 / 13 / 12 / 9) and GND for preventing Punch-through Current.

Note 2: GND pattern to be laid out at one point in order to prevent common impedance.

Note 3: Capacitor for noise suppression to be connected between the Power Supply (V_{CC} , V_M) and GND to stabilize the operation.

Note 4: Utmost care is necessary in the design of the output, V_{CC} , V_M , and GND lines since the IC may be destroyed by short-circuiting between outputs, air contamination faults, or faults due to improper grounding, or by short-circuiting between contiguous pins.

PACKAGE DIMENSIONS

SSOP24-P-300-1.00

Unit : mm

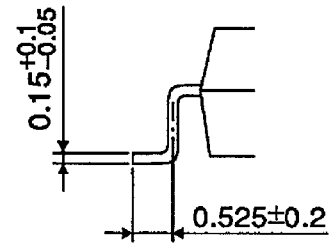
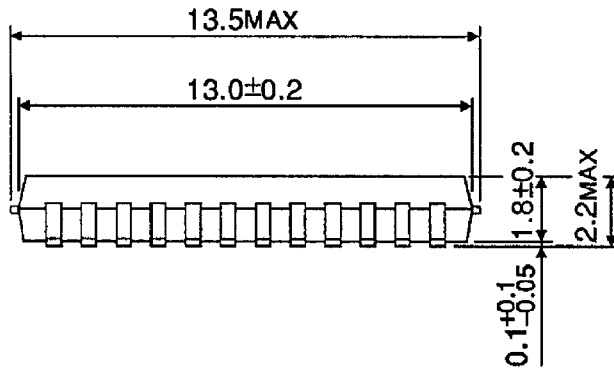
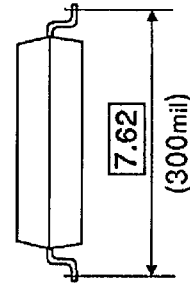
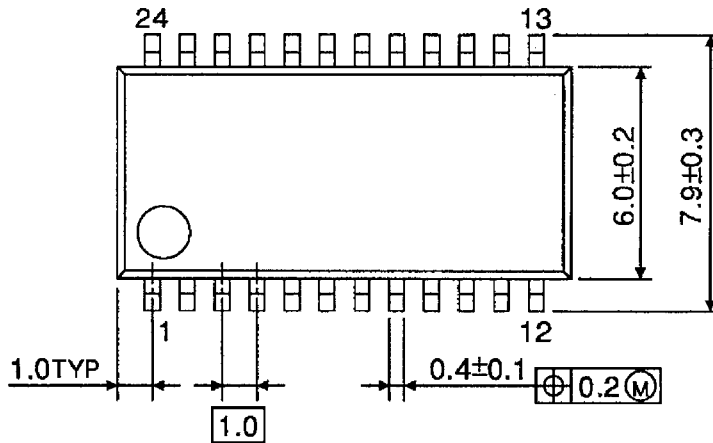

Weight : 0.32 g (Typ.)

Notes on Contents

1. Block Diagrams

Some of the functional blocks, circuits, or constants in the block diagram may be omitted or simplified for explanatory purposes.

2. Equivalent Circuits

The equivalent circuit diagrams may be simplified or some parts of them may be omitted for explanatory purposes.

3. Timing Charts

Timing charts may be simplified for explanatory purposes.

4. Application Circuits

The application circuits shown in this document are provided for reference purposes only. Thorough evaluation is required, especially at the mass production design stage.

Toshiba does not grant any license to any industrial property rights by providing these examples of application circuits.

5. Test Circuits

Components in the test circuits are used only to obtain and confirm the device characteristics. These components and circuits are not guaranteed to prevent malfunction or failure from occurring in the application equipment.

IC Usage Considerations

Notes on handling of ICs

- [1] The absolute maximum ratings of a semiconductor device are a set of ratings that must not be exceeded, even for a moment. Do not exceed any of these ratings.
Exceeding the rating(s) may cause the device breakdown, damage or deterioration, and may result injury by explosion or combustion.
- [2] Use an appropriate power supply fuse to ensure that a large current does not continuously flow in case of over current and/or IC failure. The IC will fully break down when used under conditions that exceed its absolute maximum ratings, when the wiring is routed improperly or when an abnormal pulse noise occurs from the wiring or load, causing a large current to continuously flow and the breakdown can lead smoke or ignition. To minimize the effects of the flow of a large current in case of breakdown, appropriate settings, such as fuse capacity, fusing time and insertion circuit location, are required.
- [3] If your design includes an inductive load such as a motor coil, incorporate a protection circuit into the design to prevent device malfunction or breakdown caused by the current resulting from the inrush current at power ON or the negative current resulting from the back electromotive force at power OFF. IC breakdown may cause injury, smoke or ignition.
Use a stable power supply with ICs with built-in protection functions. If the power supply is unstable, the protection function may not operate, causing IC breakdown. IC breakdown may cause injury, smoke or ignition.
- [4] Do not insert devices in the wrong orientation or incorrectly.
Make sure that the positive and negative terminals of power supplies are connected properly.
Otherwise, the current or power consumption may exceed the absolute maximum rating, and exceeding the rating(s) may cause the device breakdown, damage or deterioration, and may result injury by explosion or combustion.
In addition, do not use any device that is applied the current with inserting in the wrong orientation or incorrectly even just one time.

Points to remember on handling of ICs**(1) Heat Radiation Design**

In using an IC with large current flow such as power amp, regulator or driver, please design the device so that heat is appropriately radiated, not to exceed the specified junction temperature (T_j) at any time and condition. These ICs generate heat even during normal use. An inadequate IC heat radiation design can lead to decrease in IC life, deterioration of IC characteristics or IC breakdown. In addition, please design the device taking into consideration the effect of IC heat radiation with peripheral components.

(2) Back-EMF

When a motor rotates in the reverse direction, stops or slows down abruptly, a current flows back to the motor's power supply due to the effect of back-EMF. If the current sink capability of the power supply is small, the device's motor power supply and output pins might be exposed to conditions beyond maximum ratings. To avoid this problem, take the effect of back-EMF into consideration in system design.

RESTRICTIONS ON PRODUCT USE

060116EBA

- The information contained herein is subject to change without notice. 021023_D
- TOSHIBA is continually working to improve the quality and reliability of its products. Nevertheless, semiconductor devices in general can malfunction or fail due to their inherent electrical sensitivity and vulnerability to physical stress. It is the responsibility of the buyer, when utilizing TOSHIBA products, to comply with the standards of safety in making a safe design for the entire system, and to avoid situations in which a malfunction or failure of such TOSHIBA products could cause loss of human life, bodily injury or damage to property.
In developing your designs, please ensure that TOSHIBA products are used within specified operating ranges as set forth in the most recent TOSHIBA products specifications. Also, please keep in mind the precautions and conditions set forth in the "Handling Guide for Semiconductor Devices," or "TOSHIBA Semiconductor Reliability Handbook" etc. 021023_A
- The TOSHIBA products listed in this document are intended for usage in general electronics applications (computer, personal equipment, office equipment, measuring equipment, industrial robotics, domestic appliances, etc.). These TOSHIBA products are neither intended nor warranted for usage in equipment that requires extraordinarily high quality and/or reliability or a malfunction or failure of which may cause loss of human life or bodily injury ("Unintended Usage"). Unintended Usage include atomic energy control instruments, airplane or spaceship instruments, transportation instruments, traffic signal instruments, combustion control instruments, medical instruments, all types of safety devices, etc. Unintended Usage of TOSHIBA products listed in this document shall be made at the customer's own risk. 021023_B
- The products described in this document shall not be used or embedded to any downstream products of which manufacture, use and/or sale are prohibited under any applicable laws and regulations. 060106_Q
- The information contained herein is presented only as a guide for the applications of our products. No responsibility is assumed by TOSHIBA for any infringements of patents or other rights of the third parties which may result from its use. No license is granted by implication or otherwise under any patent or patent rights of TOSHIBA or others. 021023_C
- The products described in this document are subject to the foreign exchange and foreign trade laws. 021023_E