

**Small Form Factor  
Single Mode 1300 nm 622 Mbit/s Transceiver  
2x5 Pinning with LC™ Connector, with Collar**

**V23818-H18-Lxx/Lxxx**

**Preliminary Data**

**Features**

- Small Form Factor MSA compliant transceiver<sup>1)</sup>
- RJ-45 style LC™ connector system
- Half the size of SC Duplex 1x9 transceiver
- Single power supply (3.3 V)
- Extremely low power consumption
- Loss of optical signal indicator
- Laser disable input
- LVPECL differential inputs and outputs
- Distance up to 21 km on single mode fiber (SMF)
- Class 1 FDA and IEC laser safety compliant
- Multisource footprint
- Small footprint for high channel density
- UL 94 V-0 certified
- Compliant with FCC (Class B) and EN 55022
- SFF evaluation board V23818-S5-V13 (AC/AC) or V23818-S5-V14 (DC/DC) available upon request

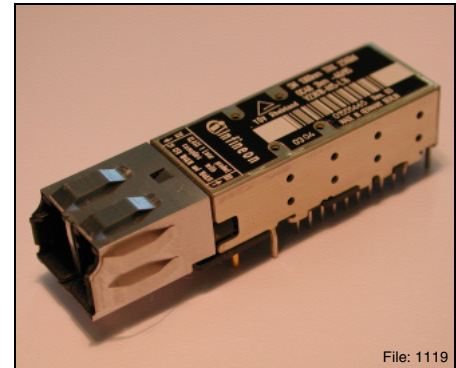

File: 1119

<sup>1)</sup> MSA documentation can be found at [www.infineon.com/fiberoptics](http://www.infineon.com/fiberoptics) under Transceivers.

LC™ is a trademark of Lucent

Part Number	Pinning	Operating Temperature	Signal Detect	Data Outputs if SD is Low	In-put	Out-put	
V23818-H18-L37	2x5	-5°C to 70°C	LVPECL	Switched to Low	DC	DC	
V23818-H18-L36		-40°C to 85°C					
V23818-H18-L47		-5°C to 70°C	LVTTTL		Active	AC	AC
V23818-H18-L46		-40°C to 85°C					
V23818-H18-L437		-5°C to 70°C	LVPECL	Active		DC	DC
V23818-H18-L436		-40°C to 85°C					
V23818-H18-L447		-5°C to 70°C	LVTTTL		Active	AC	AC
V23818-H18-L446		-40°C to 85°C					

Pin Configuration

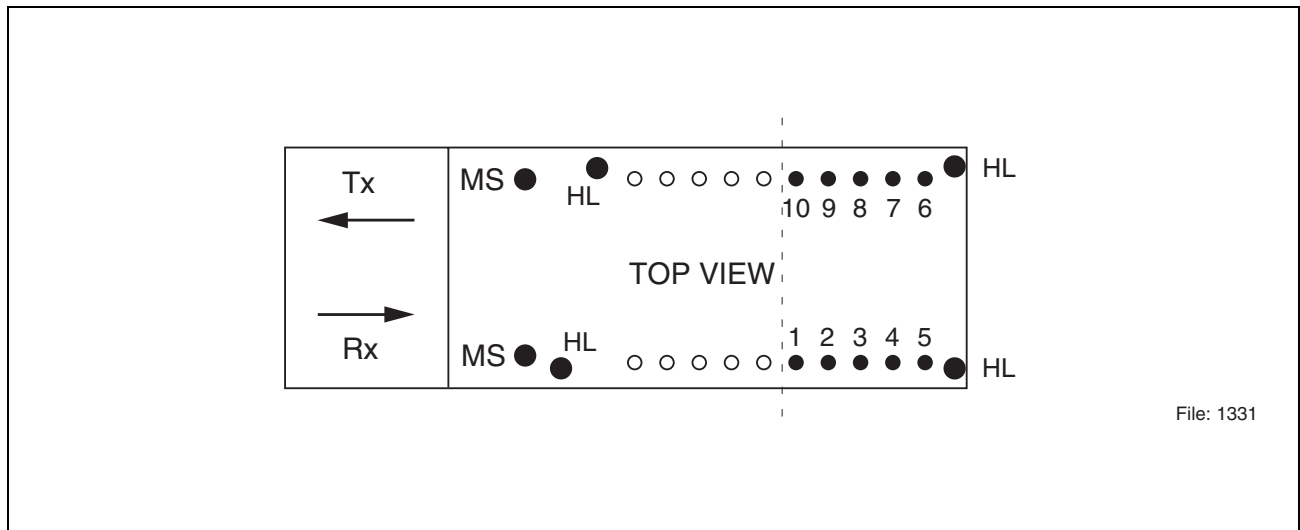

File: 1331

Figure 1

Pin Description

Pin No.	Symbol	Level/Logic	Description
1	$V_{EEr}$	Ground	Receiver signal ground
2	$V_{CCr}$	Power supply	Receiver power supply
3	SD	LVTTTL or LVPECL output <sup>1)</sup>	Receiver optical input level monitor
4	RD-	LVPECL output	Receiver data out bar
5	RD+	LVPECL output	Receiver data out
6	$V_{CCt}$	Power supply	Transmitter power supply
7	$V_{EEt}$	Ground	Transmitter signal ground
8	TDis	LVTTTL input	Transmitter disable
9	TD+	LVPECL input	Transmitter data in
10	TD-	LVPECL input	Transmitter data in bar
MS			Mounting studs
HL			Housing leads

<sup>1)</sup> LVPECL output active high for V23818-H18-L37/L36/L437/L436.  
 LVTTTL output active high for V23818-H18-L47/L46/L447/L446.

---

## Pin Configuration

### $V_{EEr} / V_{EEt}$

Connect pins 1 and 7 to signal ground.

### $V_{CCr} / V_{CCt}$

A 3.3 V DC power supply must be applied at pins 2 and 6. A recommended power supply filter network is given in the termination scheme. Locate power supply filtering directly at the transceiver power supply pins. Proper power supply filtering is essential for good EMI performance.

### **TD+ / TD-**

Transmitter data LVPECL level inputs. For V23818-H18-L47/L46/L447/L446 terminated and AC coupled internally. For V23818-H18-L37/L36/L437/L436 use termination and coupling as shown in the termination scheme.

### **RD- / RD+**

Receiver data LVPECL level outputs. For V23818-H18-L47/L46/L447/L446 biased and AC coupled internally. For V23818-H18-L37/L36/L437/L436 use termination and coupling as shown in the termination scheme.

### **TDis**

A logical LVTTTL high input will disable the laser. To enable the laser, an LVTTTL low input must be applied. Leave pin unconnected if feature not required.

### **SD**

LVTTTL output for V23818-H18-L47/L46/L447/L446. LVPECL output for V23818-H18-L37/L36/L437/L436. A logical high output indicates normal optical input levels to the receiver. Low optical input levels at the receiver result in a low output. Signal Detect can be used to determine a definite optical link failure; break in fiber, unplugging of a connector, faulty laser source. However it is not a detection of a bad link due to data-related errors.

### **MS**

Mounting studs are provided for transceiver mechanical attachment to the circuit board. They also provide an optional connection of the transceiver to the equipment chassis ground. The holes in the circuit board must be tied to chassis ground.

### **HL**

Housing leads are provided for additional signal grounding. The holes in the circuit board must be included and tied to signal ground.

**Description**
**Description**

The Infineon 622 Megabit single mode transceiver – part of Infineon Small Form Factor transceiver family – complies with the ATM Forum’s Network Compatible ATM for Local Network Applications document and ANSI’s Broadband ISDN - Customer Installation Interfaces, Physical Media Dependent Specification, T1.646-1995, SONET OC-12 IR-1, Telcordia GR-253-CORE and STM-4 S-4.1 (ITU-T G.957).

The appropriate fiber optic cable is 9 μm single mode fiber with LC connector.

**Supported Link Lengths**

Category within Standard	Reach		Unit
	min.	max. <sup>1)</sup>	
SDH STM S-4.1	0	15,000	meters
SONET OC-12 IR-1	0	21,000	

<sup>1)</sup> Maximum reach over fiber type SM-G.652 as defined by ITU-T G.957 and Telcordia GR-253-CORE standards. Longer reach possible depending upon link implementation.

The Infineon OC-12 single mode transceiver is a single unit comprised of a transmitter, a receiver, and an LC receptacle. This design frees the customer from many alignment and PC board layout concerns.

This transceiver supports the LC connectorization concept, which competes with UTP/CAT 5 solutions. It is compatible with RJ-45 style backpanels for fiber-to-the-desktop applications while providing the advantages of fiber optic technology. The receptacle accepts the new LC connector. The Small Form Factor is specially developed for distances of up to 15 km.

The module is designed for low cost LAN and WAN applications. It can be used as the network end device interface in mainframes, workstations, servers, and storage devices, and in a broad range of network devices such as bridges, routers, hubs, and local and wide area switches.

This transceiver operates at 622 Mbit/s from a single power supply (+3.3 V). The full differential data inputs and outputs are LVPECL compatible.

### Functional Description of SFF Transceiver

This transceiver is designed to transmit serial data via single mode fiber.

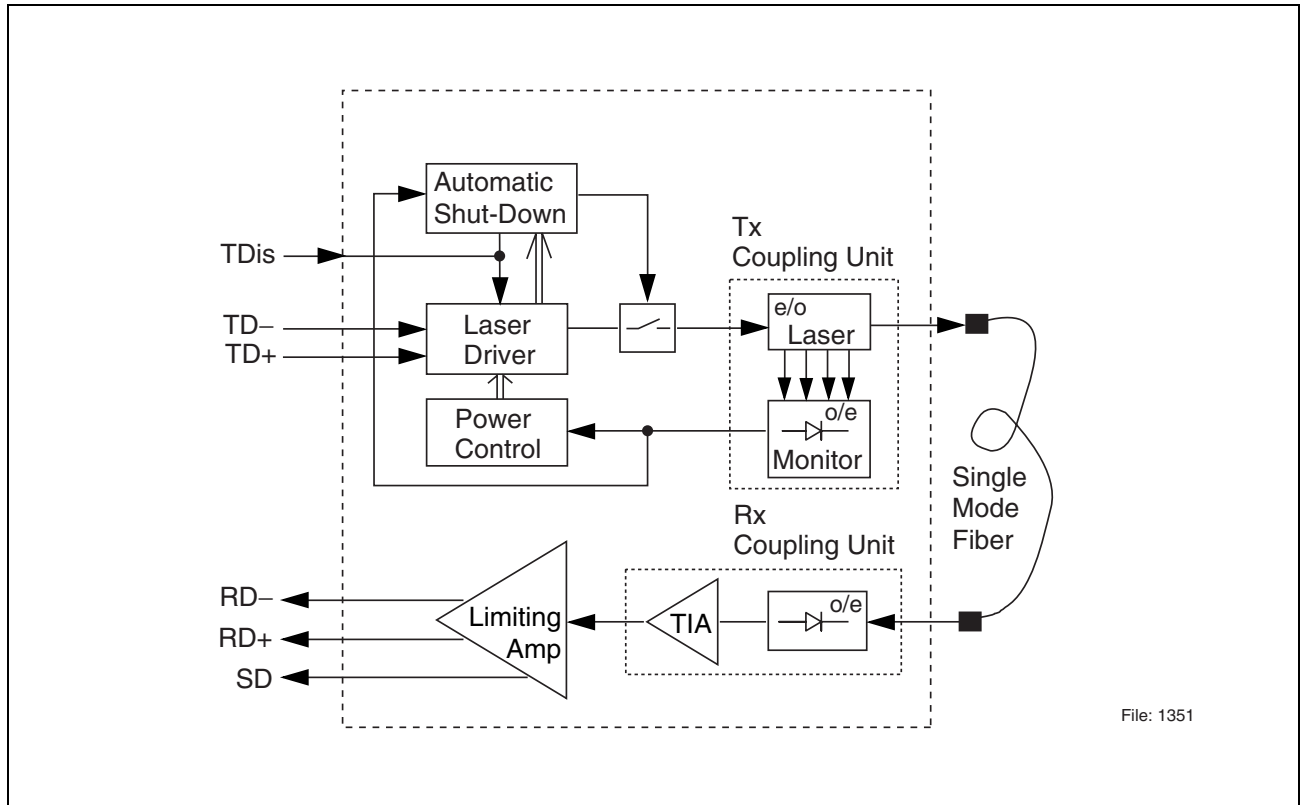

**Figure 2 Functional Diagram**

The receiver component converts the optical serial data into an electrical data (RD+ and RD-). The Signal Detect output (SD) shows whether an optical signal is present.

The transmitter part converts electrical LVPECL compatible serial data (TD+ and TD-) into optical serial data.

The module has an integrated shutdown function that switches the laser off in the event of an internal failure.

Reset is only possible if the power is turned off, and then on again. ( $V_{CCt}$  switched below  $V_{TH}$ ).

**Regulatory Compliance**

Feature	Standard	Comments
ESD: Electrostatic Discharge to the Electrical Pins	EIA/JESD22-A114-B (MIL-STD 883D Method 3015.7)	Class 1C
Immunity: Against Electrostatic Discharge (ESD) to the Duplex LC Receptacle	EN 61000-4-2 IEC 61000-4-2	Discharges ranging from $\pm 2$ kV to $\pm 15$ kV on the receptacle cause no damage to transceiver (under recommended conditions).
Immunity: Against Radio Frequency Electromagnetic Field	EN 61000-4-3 IEC 61000-4-3	With a field strength of 3 V/m, noise frequency ranges from 10 MHz to 2 GHz. No effect on transceiver performance between the specification limits.
Emission: Electromagnetic Interference (EMI)	FCC 47 CFR Part 15, Class B EN 55022 Class B CISPR 22	Noise frequency range: 30 MHz to 18 GHz

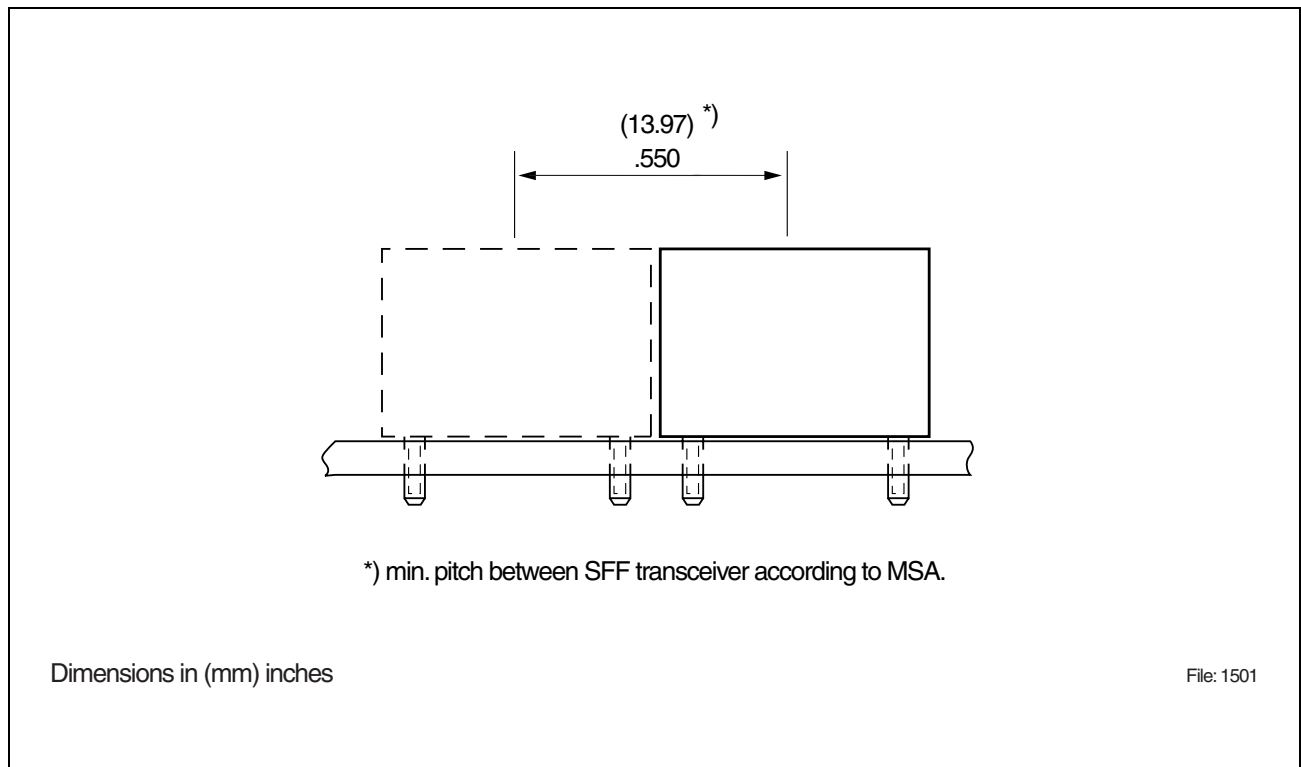

**Figure 3 Transceiver Pitch**

**Technical Data**
**Absolute Maximum Ratings**

Parameter	Symbol	Limit Values		Unit
		min.	max.	
Package Power Dissipation			0.9	W
Supply Voltage	$V_{CC}-V_{EE}$		4	V
Data Input Levels		$V_{CC}+0.5$	$V_{EE}-0.5$	V
Differential Data Input Voltage Swing	$V_{IDpk-pk}$		5	V
Operating Case Temperature V23818-H18-L36/L46/L436/L446 V23818-H18-L37/L47/L437/L447		-40 -5	85 70	°C
Storage Ambient Temperature		-40	85	°C
Soldering Conditions Temp/Time			260/10	°C/s

Exceeding any one of these values may destroy the device immediately.

**Recommended Operating Conditions**

Parameter	Symbol	Limit Values			Unit
		min.	typ.	max.	
Ambient Temperature <sup>1) 3)</sup>	$T_{AMB}$	-40		85	°C
Ambient Temperature <sup>2) 3)</sup>		-5		70	
Power Supply Voltage	$V_{CC}-V_{EE}$	3.14	3.3	3.46	V
Supply Current	$I_{CC}$			230	mA

**Transmitter**

Data Input High Voltage	$V_{IH}-V_{CC}$	-1165		-880	mV
Differential Data Input Voltage Swing	$V_{IDpk-pk}$	250		1600	mV
Data Input Low Voltage	$V_{IL}-V_{CC}$	-1810		-1475	mV
Data Input Rise/Fall Time	$t_i$			120	ps

**Receiver**

Input Center Wavelength	$\lambda_{Rx}$	1260		1580	nm
-------------------------	----------------	------	--	------	----

<sup>1)</sup> For V23818-H18-L36/L46/L436/L446.

<sup>2)</sup> For V23818-H18-L37/L47/L437/L447.

<sup>3)</sup> Ambient operating temperature requires a 2 ms<sup>-1</sup> airflow over the device.

The electro-optical characteristics described in the following tables are valid only for use under the recommended operating conditions.

**Transmitter Electro-Optical Characteristics**

Transmitter	Symbol	Limit Values			Unit
		min.	typ.	max.	
Output Power (Average) <sup>1)</sup>	$P_O$	-15		-8	dBm
Center Wavelength	$\lambda_C$	1274		1356	nm
Spectral Width (rms)	$\sigma$			2.5	nm
Extinction Ratio (Dynamic)	ER	8.2			dB
Eye Diagram	ED	ITU-T G.957 mask pattern			
Reset Threshold for $V_{CCt}$ <sup>2)</sup>	$V_{TH}$		2.7		V
Power on Delay <sup>2)</sup>	$t_{DEL}$		30		ms
Jitter Generation <sup>3)</sup>	$J_{GEpk-pk}$			0.1	UI
	$J_{GErms}$			0.01	UI

<sup>1)</sup> Into single mode fiber, 9  $\mu$ m diameter

<sup>2)</sup> Laser power is shut down if power supply is below  $V_{TH}$  and switched on if power supply is above  $V_{TH}$  after  $t_{RES}$ .

<sup>3)</sup> The transceiver is specified to meet the SONET/SDH Jitter performance as outlined in ITU-T G.958 and Telcordia GR-253. Jitter Generation is defined as the amount of jitter that is generated by the transceiver. The Jitter Generation specifications are referenced to the optical OC-12 signals. If no or minimum jitter is applied to the electrical inputs of the transmitter, then Jitter Generation can simply be defined as the amount of jitter on the Tx optical output. The SONET specifications for Jitter Generation are 0.01 UI rms, maximum and 0.1 UI pk-pk, maximum. For SDH, 10 mUI rms, maximum. Both are measured with a 12 kHz - 5 MHz filter in line. A UI is a Unit Interval, which is equivalent to one bit slot. At OC-12, the bit slot is 1.6 ns, so the Jitter Generation specification translates to 16 ps rms, max. and 160 ps pk-pk, max.



**Receiver Electro-Optical Characteristics**

Receiver	Symbol	Limit Values			Unit
		min.	typ.	max.	
Sensitivity (Average Power) <sup>1)</sup>	$P_{IN}$			-28	dBm
Saturation (Average Power)	$P_{SAT}$	-8			dBm
Signal Detect Assert Level <sup>2)</sup>	$P_{SDA}$			-28	dBm
Signal Detect Deassert Level <sup>3)</sup>	$P_{SDD}$	-37			dBm
Signal Detect Hysteresis	$P_{SDA}$ $-P_{SDD}$		3		dB
Signal Detect Assert Time <sup>2)</sup>	$t_{ASS}$			0.1	ms
Signal Detect Deassert Time <sup>3)</sup>	$t_{DAS}$			0.35	ms
Output Voltage <sup>4)</sup>	$V_{OH}-V_{CC}$	-1110		-650	mV
Output Voltage <sup>4)</sup>	$V_{OL}-V_{CC}$	-1800		-1300	mV
Differential Data Output Voltage Swing <sup>4)</sup>	$V_{ODpk-pk}$	1000		2000	mV
Signal Detect Output High Voltage LVPECL <sup>5) 6)</sup>	$V_{SDH}-V_{EE}$	$V_{CC}$ -1200		$V_{CC}$ -820	mV
Signal Detect Output Low Voltage LVPECL <sup>5) 6)</sup>	$V_{SDL}-V_{EE}$	$V_{CC}$ -1900		$V_{CC}$ -1580	mV
Signal Detect Output High Voltage LVTTTL <sup>5) 7)</sup>	$V_{SDH}$	2.4			V
Signal Detect Output Low Voltage LVTTTL <sup>5) 7)</sup>	$V_{SDL}$			0.5	V

<sup>1)</sup> Minimum average optical power at which the BER is less than  $1 \times 10^{-10}$ . Measured with a  $2^{23}-1$  NRZ PRBS as recommended by ANSI T1E1.2, SONET OC-12, and ITU-T G.957.

<sup>2)</sup> An increase in optical power above the specified level will cause the Signal Detect to switch from a low state to a high state (high active output).

<sup>3)</sup> A decrease in optical power below the specified level will cause the Signal Detect to switch from a high state to a low state.

<sup>4)</sup> Load is 100  $\Omega$  differential.

<sup>5)</sup> Internal load is 510  $\Omega$  to GND, no external load necessary. Signal Detect is a high active output. High level means signal is present, low level means loss of signal.

<sup>6)</sup> For V23818-H18-L37/L36/L437/L436.

<sup>7)</sup> For V23818-H18-L47/L46/L447/L446.

**Eye Safety**

This laser based single mode transceiver is a Class 1 product. It complies with IEC 60825-1 and FDA 21 CFR 1040.10 and 1040.11.

To meet laser safety requirements the transceiver shall be operated within the Absolute Maximum Ratings.

**Attention: All adjustments have been made at the factory prior to shipment of the devices. No maintenance or alteration to the device is required. Tampering with or modifying the performance of the device will result in voided product warranty.**

*Note: Failure to adhere to the above restrictions could result in a modification that is considered an act of “manufacturing”, and will require, under law, recertification of the modified product with the U.S. Food and Drug Administration (ref. 21 CFR 1040.10 (i)).*

**Laser Data**

Wavelength	1300 nm
Total output power (as defined by IEC: 7 mm aperture at 14 mm distance)	< 2 mW
Total output power (as defined by FDA: 7 mm aperture at 20 cm distance)	< 180 μW
Beam divergence	4°

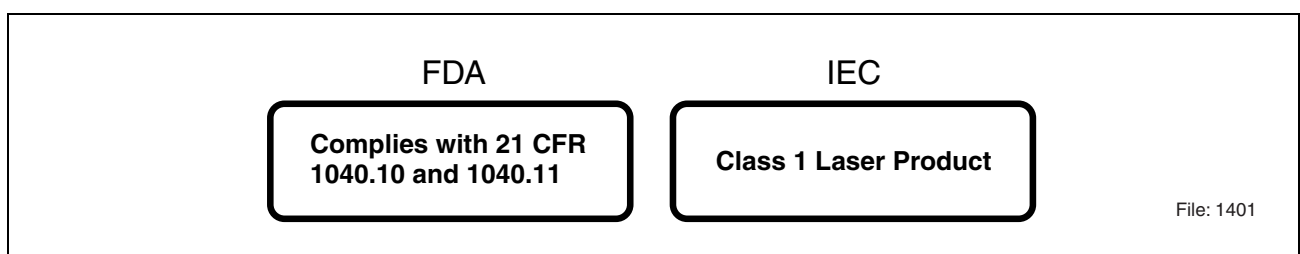

**Figure 4 Required Labels**

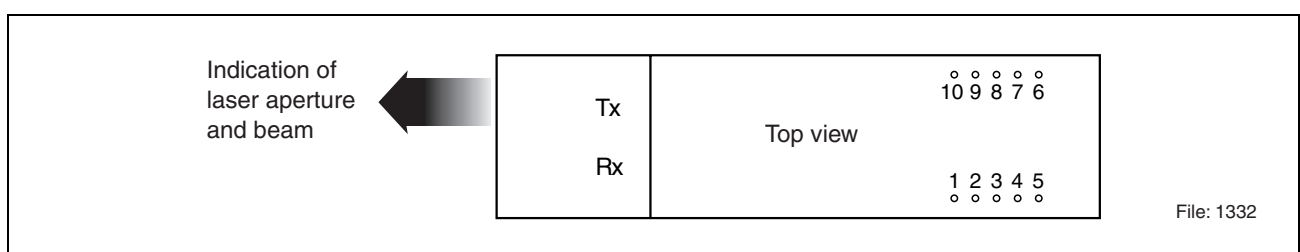

**Figure 5 Laser Emission**

## EMI-Recommendations

To avoid electromagnetic radiation exceeding the required limits please take note of the following recommendations.

When Gigabit switching components are found on a PCB (multiplexers, clock recoveries etc.) any opening of the chassis may produce radiation also at chassis slots other than that of the device itself. Thus every mechanical opening or aperture should be as small as possible.

On the board itself every data connection should be an impedance matched line (e.g. strip line, coplanar strip line). Data, Datanot should be routed symmetrically, vias should be avoided. A terminating resistor of 100  $\Omega$  should be placed at the end of each matched line. An alternative termination can be provided with a 50  $\Omega$  resistor at each (D, Dn). In DC coupled systems a thevenin equivalent 50  $\Omega$  resistance can be achieved as follows: for 3.3 V: 125  $\Omega$  to  $V_{CC}$  and 82  $\Omega$  to  $V_{EE}$ , for 5 V: 82  $\Omega$  to  $V_{CC}$  and 125  $\Omega$  to  $V_{EE}$  at Data and Datanot. Please consider whether there is an internal termination inside an IC or a transceiver.

In certain cases signal GND is the most harmful source of radiation. Connecting chassis GND and signal GND at the plate/bezel/chassis rear e.g. by means of a fiber optic transceiver may result in a large amount of radiation. Even a capacitive coupling between signal GND and chassis may be harmful if it is too close to an opening or an aperture.

If a separation of signal GND and chassis GND is not planned, it is strongly recommended to provide a proper contact between signal GND and chassis GND at every location where possible. This concept is designed to avoid hotspots. Hotspots are places of highest radiation which could be generated if only a few connections between signal and chassis GND exist. Compensation currents would concentrate at these connections, causing radiation.

By use of Gigabit switching components in a design, the return path of the RF current must also be considered. Thus a split GND plane of Tx and Rx portion may result in severe EMI problems.

A recommendation is to connect the housing leads to signal GND. However, in certain applications it may improve EMI performance by connecting them to chassis GND.

The cutout should be sized so that all contact springs make good contact with the face plate.

Please consider that the PCB may behave like a waveguide. With an  $\epsilon_r$  of 4, the wavelength of the harmonics inside the PCB will be half of that in free space. In this scenario even the smallest PCBs may have unexpected resonances.

Recommended Termination Schemes

Recommended Termination Schemes

2x5 DC/DC Transceiver

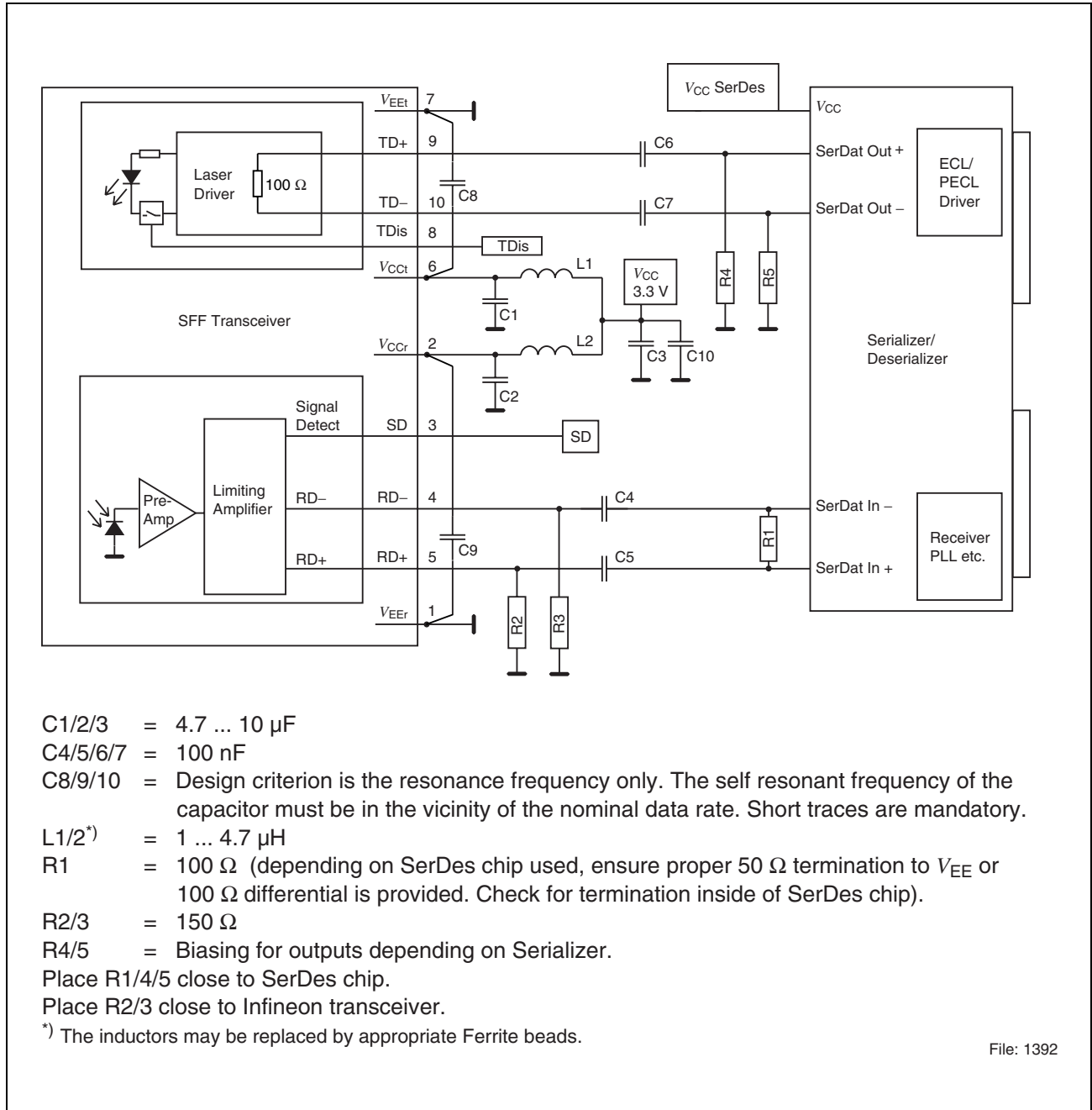

Figure 6

Recommended Termination Schemes

2x5 AC/AC Transceiver

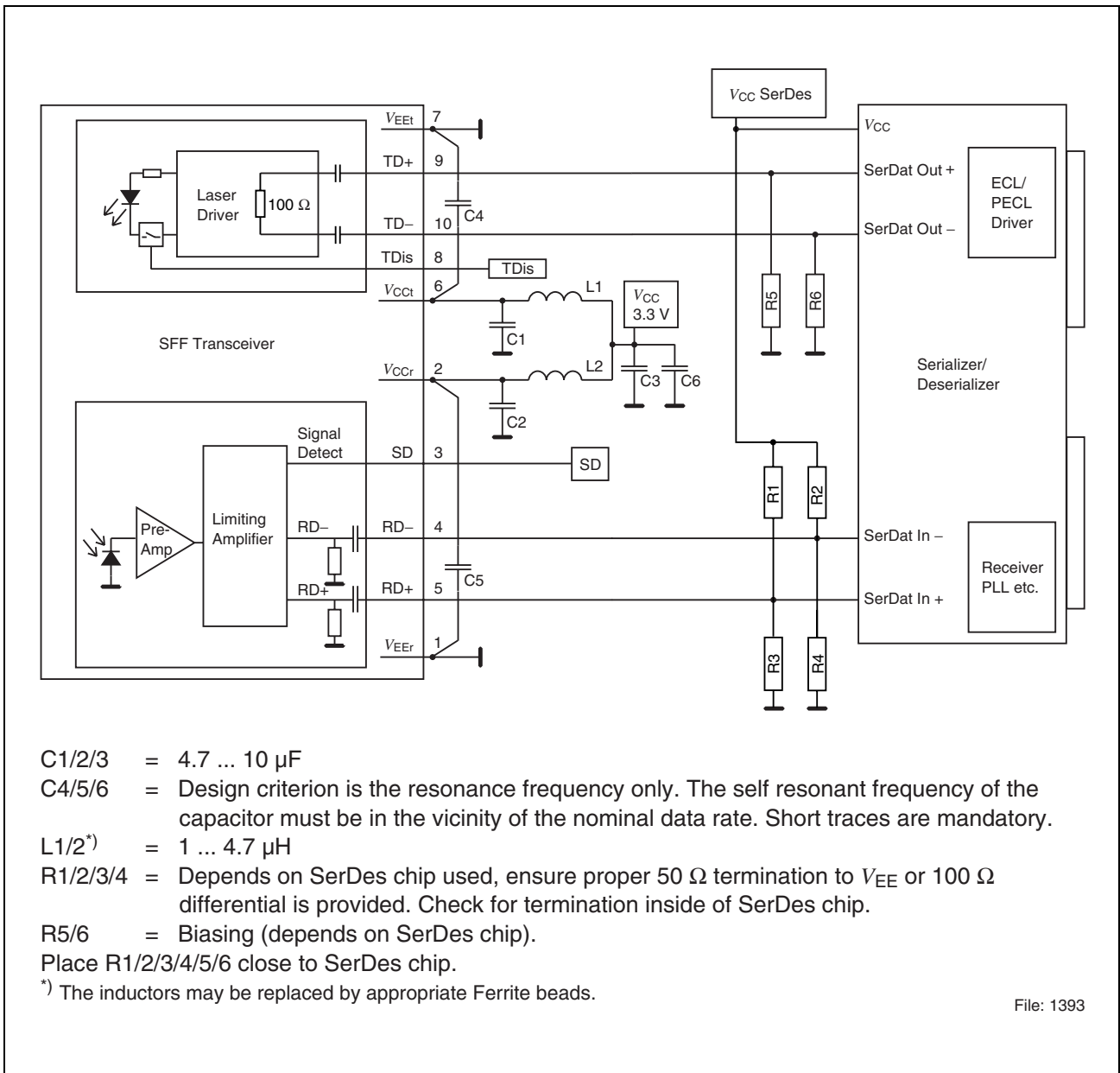

Figure 7

Package Outlines

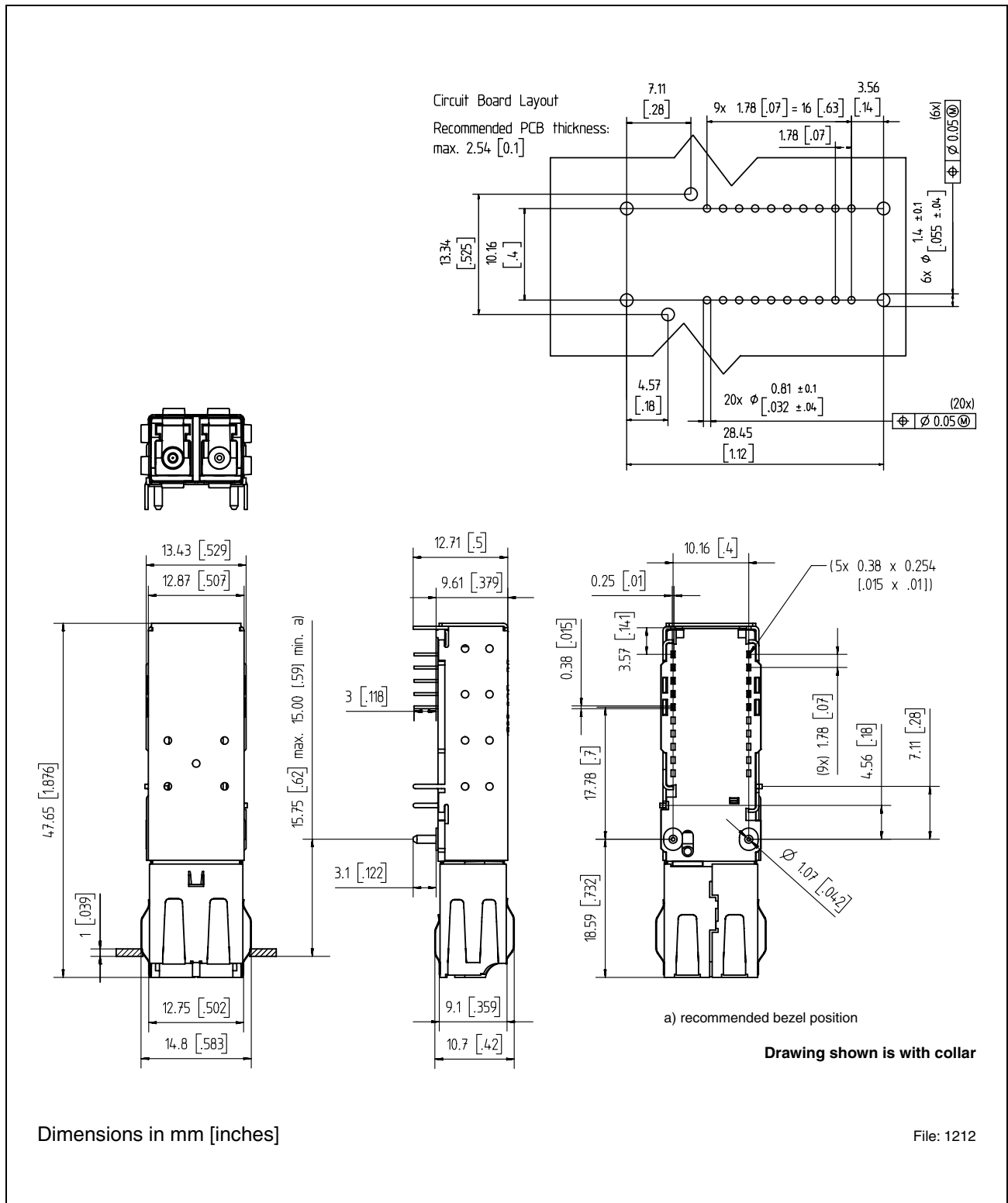

Figure 8

**Revision History: 2003-04-24**

DS1

Previous Version: 2001-10-01

---

<b>Page</b>	<b>Subjects (major changes since last revision)</b>
	Document completely revised; V23818-H18-L17/L16/L57/L56 (2x10) removed, V23818-H18-L437/L436/L447/L446 (2x5) added.

---

For questions on technology, delivery and prices please contact the Infineon Technologies Offices in Germany or the Infineon Technologies Companies and Representatives worldwide: see our webpage at <http://www.infineon.com>.

**Edition 2003-04-24****Published by Infineon Technologies AG,  
St.-Martin-Strasse 53,  
D-81541 München, Germany****© Infineon Technologies AG 2003.  
All Rights Reserved.****Attention please!**

The information herein is given to describe certain components and shall not be considered as warranted characteristics.

Terms of delivery and rights to technical change reserved.

We hereby disclaim any and all warranties, including but not limited to warranties of non-infringement, regarding circuits, descriptions and charts stated herein.

Infineon Technologies is an approved CECC manufacturer.

**Information**

For further information on technology, delivery terms and conditions and prices please contact your nearest Infineon Technologies Office in Germany or our Infineon Technologies Representatives worldwide.

**Warnings**

Due to technical requirements components may contain dangerous substances. For information on the types in question please contact your nearest Infineon Technologies Office.

Infineon Technologies Components may only be used in life-support devices or systems with the express written approval of Infineon Technologies, if a failure of such components can reasonably be expected to cause the failure of that life-support device or system, or to affect the safety or effectiveness of that device or system. Life-support devices or systems are intended to be implanted in the human body, or to support and/or maintain and sustain and/or protect human life. If they fail, it is reasonable to assume that the health of the user or other persons may be endangered.