

# WJ-A31-1 / SMA31-1

10 to 2000 MHz  
TO-8 CASCADABLE AMPLIFIER

- ◆ AVAILABLE IN SURFACE MOUNT
- ◆ LOW NOISE: < 3.5 dB (TYP.)
- ◆ LOW VSWR : 1.5:1 (TYP.)

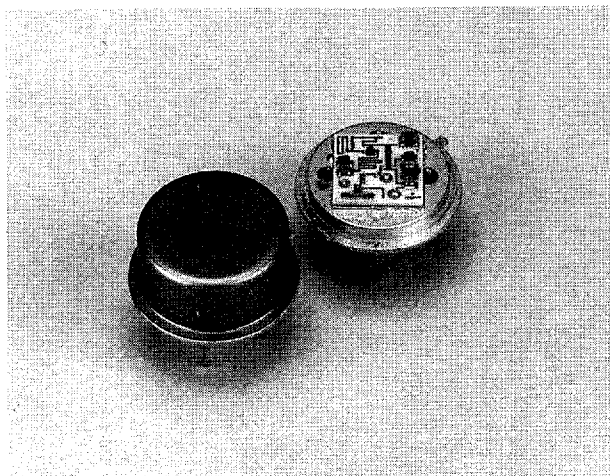

## Specifications\*

Characteristics	Typical	Guaranteed	
		0° to 50°C	-54° to +85°C
Frequency (Min.)	1-2050 MHz	10-2000 MHz	10-2000 MHz
Small Signal Gain (Min.)	11.5 dB	11.0 dB	10.5 dB
Gain Flatness (Max.)	< ±0.4 dB	±0.7 dB	±1.0 dB
Noise Figure (Max.)	< 3.5 dB	4.0 dB	4.5 dB
Power Output at 1 dB Compression (Min.)	-2.0 dBm	-4.0 dBm	-4.5 dBm
VSWR (Max.)			
Input	1.5:1	2.0:1	2.0:1
output	1.3:1	2.0:1	2.0:1
DC Current (Max.) at 15 Volts	9 mA	11 mA	12 mA

\*Measured in a 50-ohm system at +15 Vdc Nominal.

Notes:

1. WJ-CA31-1 is a standard WJ-A31-1 installed in a miniature SMA connector housing and guaranteed over 0°C to 50°C temperature range.

## Typical Intermodulation Performance at 25°C

- Second Order Harmonic Intercept Point.....+15 dBm (Typ.)  
 Second Order Two Tone Intercept Point.....+10 dBm (Typ.)  
 Third Order Two Tone Intercept Point.....+9 dBm (Typ.)

## Absolute Maximum Ratings

- Storage Temperature .....-62°C to +125°C  
 Maximum Case Temperature .....125°C  
 Maximum DC Voltage.....+18 Volts  
 Maximum Continuous RF Input Power.....+13 dBm  
 Maximum Short Term RF Input Power.....50 Milliwatts (1 Minute Max.)  
 Maximum Peak Power .....0.5 Watt (3 μsec Max.)  
 "S"Series Burn-in Temperature.(Case) .....125°C

Weight approximately 2.0 grams (0.07 oz.)

## Outline Drawings

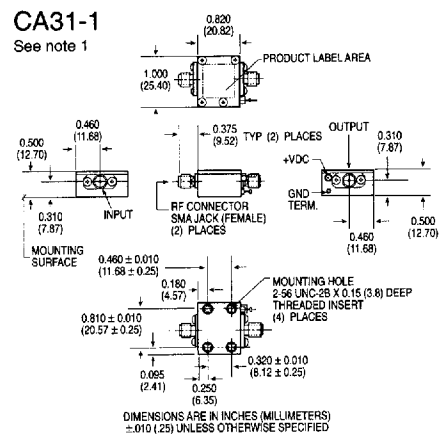
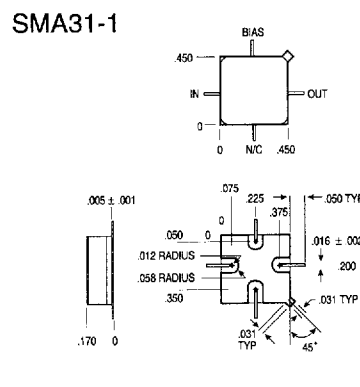
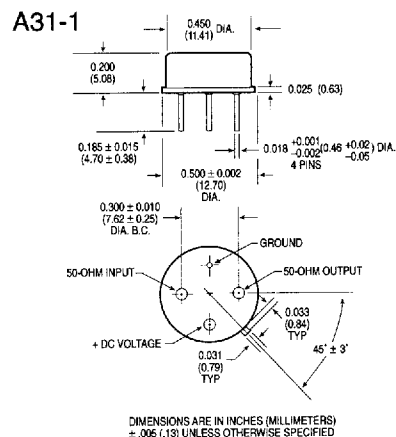

# Typical Performance at 25°C

# Typical Automatic Test Data

## Gain

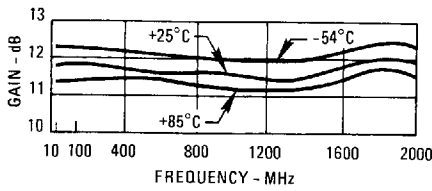

## Noise Figure

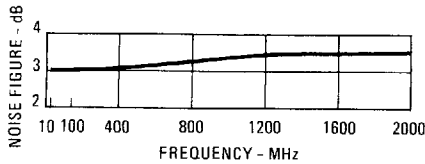

## Power Output\*

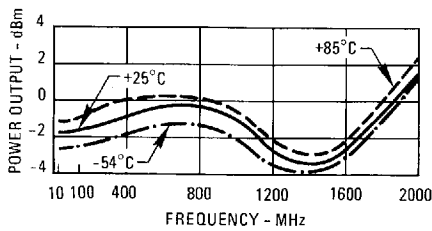

\* at 1 dB Gain Compression

## VSWR

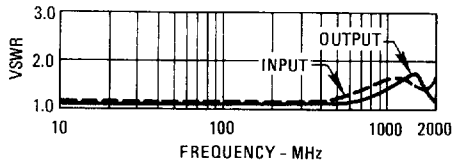

## Intercept Point

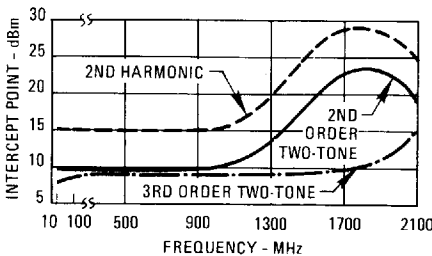

## V<sub>CC</sub> = 15.0 V

Frequency MHz	VSWR IN	VSWR OUT	GAIN DB
1.0	1.7	1.5	11.9
2.0	1.4	1.4	12.0
5.0	1.3	1.4	12.0
10.0	1.3	1.4	12.0
50.0	1.3	1.4	11.9
100.0	1.2	1.4	11.8
200.0	1.2	1.3	11.7
300.0	1.2	1.3	11.6
400.0	1.1	1.2	11.7
500.0	1.2	1.2	11.8
600.0	1.2	1.2	11.8
700.0	1.2	1.2	11.8
800.0	1.2	1.3	11.8
900.0	1.3	1.3	11.8
1000.0	1.3	1.4	11.8
1100.0	1.3	1.5	11.8
1200.0	1.4	1.5	11.8
1300.0	1.4	1.5	11.8
1400.0	1.3	1.6	12.0
1500.0	1.3	1.5	12.0
1600.0	1.3	1.5	12.2
1700.0	1.2	1.5	12.4
1800.0	1.0	1.4	12.3
1900.0	1.1	1.3	12.3
2000.0	1.5	1.2	12.1
2100.0	2.0	1.4	11.6
2200.0	3.0	1.6	10.4

## Linear S-Parameters

Frequency MHz	S11		S21		S12		S22	
	MAG	ANG	MAG	ANG	MAG	ANG	MAG	ANG
1.0	.256	-93	3.936	-170	.133	12	.200	160
2.0	.162	-124	3.960	-175	.136	6	.175	167
5.0	.128	-153	3.987	-179	.138	3	.165	172
10.0	.120	-166	3.963	180	.139	1	.161	173
50.0	.116	176	3.933	174	.140	-2	.154	164
100.0	.106	167	3.908	167	.140	-4	.149	151
200.0	.099	163	3.856	155	.141	-9	.135	126
300.0	.079	167	3.809	144	.143	-14	.117	102
400.0	.070	179	3.864	133	.143	-21	.098	80
500.0	.090	176	3.896	122	.142	-26	.089	52
600.0	.089	174	3.907	109	.140	-32	.089	15
700.0	.098	178	3.888	97	.139	-37	.099	-22
800.0	.111	176	3.896	85	.138	-44	.116	-54
900.0	.123	170	3.872	73	.138	-48	.138	-80
1000.0	.137	162	3.889	61	.136	-54	.159	-105
1100.0	.145	155	3.901	49	.136	-60	.184	-126
1200.0	.151	144	3.883	36	.133	-66	.202	-145
1300.0	.154	134	3.905	24	.131	-71	.209	-163
1400.0	.148	127	3.959	10	.130	-77	.217	179
1500.0	.128	115	3.998	-3	.128	-83	.214	161
1600.0	.116	105	4.065	-17	.128	-88	.205	142
1700.0	.082	89	4.149	-32	.129	-94	.195	124
1800.0	.023	87	4.118	-48	.132	-100	.172	109
1900.0	.066	-128	4.128	-66	.135	-108	.138	103
2000.0	.185	-151	4.049	-85	.136	-117	.110	116
2100.0	.333	-168	3.797	-107	.134	-128	.150	135
2200.0	.494	169	3.311	-128	.125	-138	.230	134

## Thermal Data: V<sub>CC</sub> = 15 Vdc

Thermal Resistance  $\theta_{jc}$  ..... 45°C/W  
 Transistor Power Dissipation  $P_d$  ..... 0.051 W  
 Junction Temperature Rise Above Case  $T_{jc}$  ... 2°C

1