

# DIGITAL CONTROL FOR A BRUSH DC MOTOR

by T. Castagnet, J. Nicolai

## ABSTRACT

In home appliances applications the brush D.C motor, driven by a chopper, can be controlled by a standard microcontroller. However, microcontrollers are often considered unsuitable for the power environment because of their limited computing speed, or problems with noise immunity.

This paper shows how a cost effective digital motor drive can be designed by combining a chopper and an 8 bit microcontroller. The speed of the motor is simply controlled through direct voltage compensation and motor power limitation.

The microcontroller performs both the motor control and interface functions of the application, replacing the analogue circuits of a conventional motor control.

Performances and practical results are given for a 300W / 12000 RPM motor drive.

## 1. INTRODUCTION

In home appliance applications the Permanent Magnet DC motor is replacing the AC universal motor, improving speed and drive performance. Traditionally, the control of this motor is implemented

using analogue circuits, with an associated microcontroller performing only an interface function.

This paper shows that a low end microcontroller can control directly a chopper driven DC motor in addition to these interface functions. In this example the adjustable speed drive is made with a 300W-2000 RPM permanent magnet DC motor for a food processor application.

## 2. THE PERMANENT MAGNET DC MOTOR AND ITS CONVERTER

The brush DC motor can be controlled by a chopper circuit. This adjustable speed drive controls the load in only one direction of rotation, and does not allow electrical braking. This type of operation is sufficient in applications such as food processors, drills or washing machines.

The design of the control circuit is simplified with the use of insulated gate transistors in the chopper, and with the use of permanent magnets for the motor excitation. Permanent magnets (e.g. ferrite materials) replace the stator windings and make an excitation circuit unnecessary, as the motor has an independent excitation. See figure 1.

**Figure 1. Application block diagram. The microcontroller generates a PWM signal and controls the IGBT through the buffer-amplifier.**

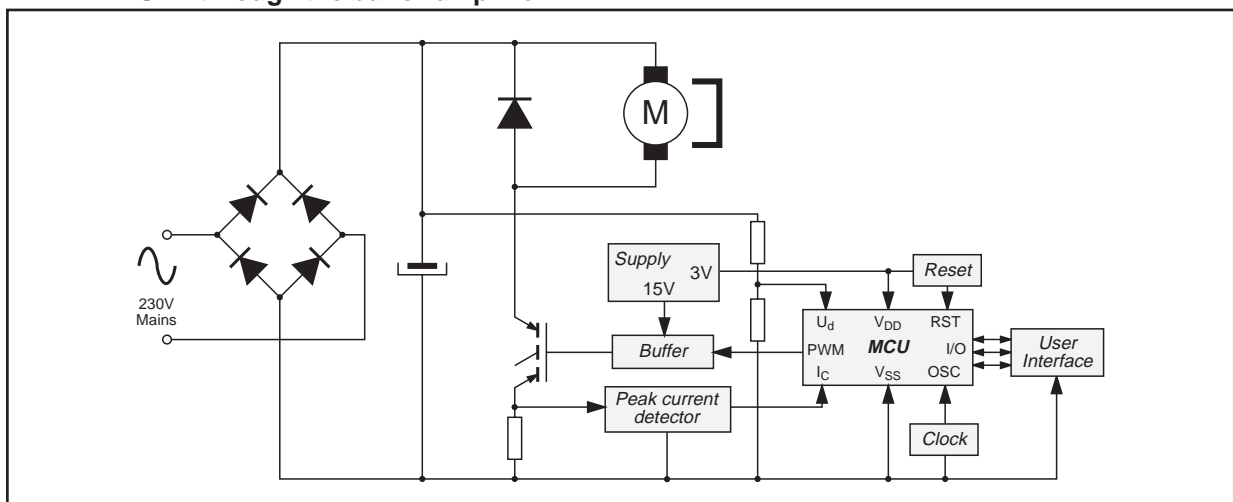

## APPLICATION NOTE

In home appliance applications the Permanent Magnet DC motor, driven by a chopper, is replacing the common AC universal motor when improved speed/drive performance is required (see appendix 1) for the following reasons:

- the motor efficiency is increased: the permanent magnets remove excitation losses, and iron and copper motor losses are reduced because the motor current ripple is reduced (more than 50%) thanks to the DC mode operation and to a suitable motor voltage control;
- the motor noise is reduced: the 100Hz torque ripple is reduced because of the motor current ripple reduction, and the switching frequency is almost inaudible;
- the motor voltage determines the speed directly because the excitation is independent; the speed is therefore stable, particularly when the torque is varies quickly (during 1s) and frequently (10 times);
- the operating speed range is increased because the motor can provide maximal torque (here  $T_{max} = 2 \text{ N.m}$ ) at low speed (less than 1000 RPM).

### 3. THE MICROCONTROLLER : THE HEART OF THE MOTOR CONTROL

In home appliance or industrial applications, microcontrollers are usually dedicated to interfacing and sequence management. Here we will show that a microcontroller can also integrate the motor control.

This speed drive is controlled by an 8-bit

microcontroller, the ST6260/65 (see figure 2).

Such microcontrollers can meet all interface and motor control requirements:

- design of interface functions is simplified due to their 8-bit analogue-to-digital converter (ADC), and their many inputs/outputs (up to 21 I/O); these allow the MCU to measure sensors, manage actuators and the user interface (for example push buttons, potentiometers, keyboard, LED diodes, bar-graph or LCD displays);
- they have additional functions useful for the design of a motor speed drive: a Pulse Width Modulation (PWM) timer for chopper control; an ADC with up to 13 inputs for voltage and current measurement; and a Non Maskable Interrupt (NMI) to generate safety protection in the Central Processor Unit (CPU).
- their safety and immunity is fully compatible with off-line circuits (hardware watchdog, careful supply lay out, decoupled oscillator, filtered inputs).

The performance required for the speed control is the following :

- accuracy of speed is not very important: there is no need for a speed sensor, and so costs are reduced; and the microcontroller adjusts the speed directly with the motor voltage;
- the motor is controlled using direct voltage compensation, and so the speed is insensitive to the input power and to variations in the mains

**Figure 2. Block diagram of the ST6260/65 micro-controller. PWM timer and A/D converter are suitable for motor control.**

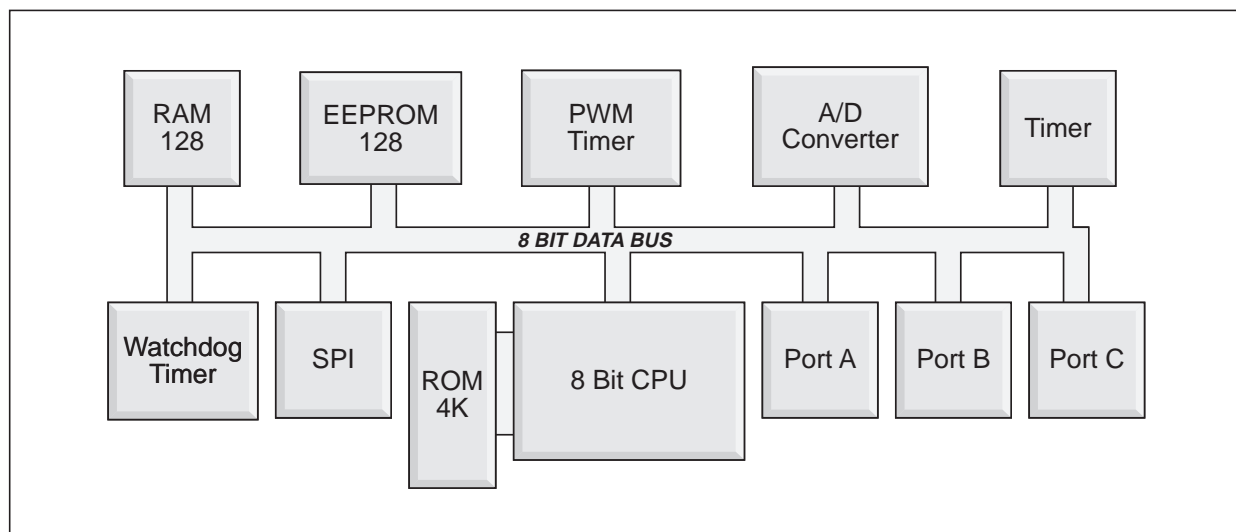

voltage; the motor current ripple is also reduced by this compensation;

- the user speed selection is performed by two +/- push buttons; its variation is adjusted by software and the start up request speed is zero ;
- the motor is protected against too big a load when the user request is out of the motor safe operating area. A 300W motor power limitation is implemented, avoiding overheating and hard brush switching ;
- the chosen chopper frequency is 8kHz : the circuit can meet the R.F.I. standards (VDE 875) with a small input filter while keeping a low switching noise level ;
- speed drive start up is validated after a voltage check of the 230V mains supply.

To achieve this speed drive, software functions have been implemented as shown in figure 3.

The autoreload PWM timer controls the switching of the chopper, generating the PWM signal. The CPU controls the duty cycle  $d$  and the switching period  $T_s$  by software (see figure 4). The duty cycle varies

**Figure 3. Main algorithm for motor control. Direct voltage compensation and motor power limitation are the key functions of the control.**

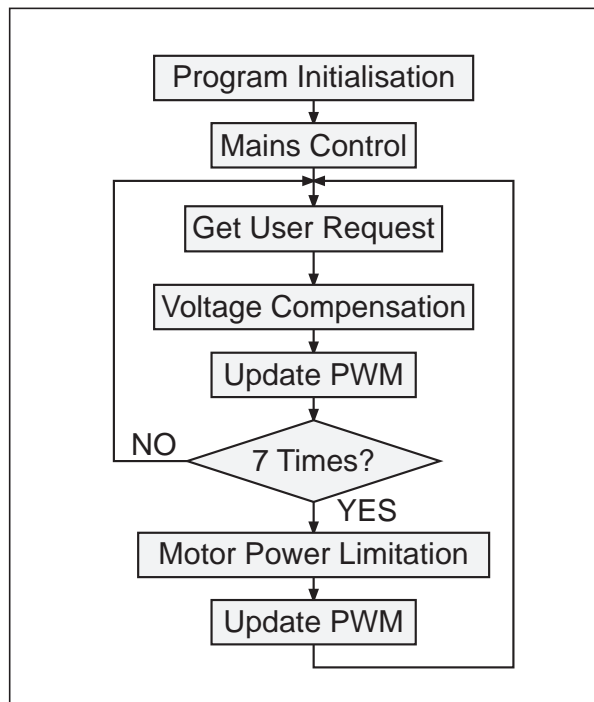

**Figure 4. Operation of the autoreload PWM timer. CPU controls the period  $T_s$  with the Reload register, and the duty cycle  $d$  with the Compare register ; the timer counts independently of the CPU.**

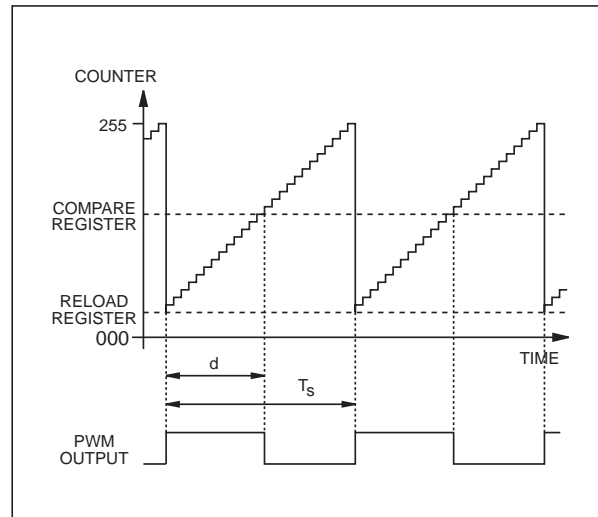

from 0 to 100%, with 0.4% (1/256) duty cycle resolution. The maximum switching frequency is 31 kHz: by software it has been adjusted to the required 8 kHz.

The direct voltage compensation aims to keep the motor voltage  $V_{mot}$  and the speed constant, particularly when the mains voltage is varying, or when the input power is transmitted to the motor. The duty cycle is modulated as a hyperbolic function of the direct voltage  $U_d$  around a reference point given by  $d_0 =$  user request duty cycle and  $U_{d(nom)} =$  nominal direct voltage:

$$V_{mot} = d \times U_d$$

$$V_{mot} = \text{constant} = d_0 \times U_{d(nom)} \quad (\text{see figure 5})$$

To achieve this,  $U_d$  is measured and quantized in 32 steps, and  $d_0$  is quantized in 16 steps: duty cycle correction is taken from a look-up table of  $U_d$  versus  $d_0$ . The correction is added to  $d_0$  and the sum is loaded into the PWM timer.

The voltage compensation needs a table of 512 bytes, and takes 380 $\mu$ s. The practical results are characterized in 2 ways :

Figure 6 demonstrates the immunity of the motor voltage to variations in  $U_d$  for a fixed speed reference. The variation of  $V_{mot}$  is less than 10% over the whole the range of values of  $U_d$ , and the speed becomes

Figure 5. Direct voltage compensation

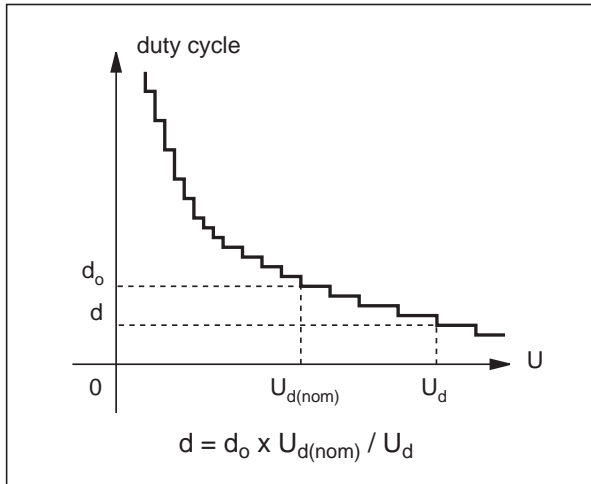

Figure 6. Static performance of direct voltage compensation

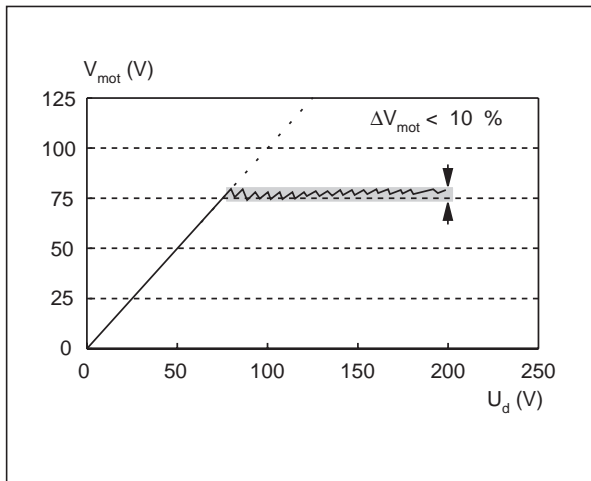
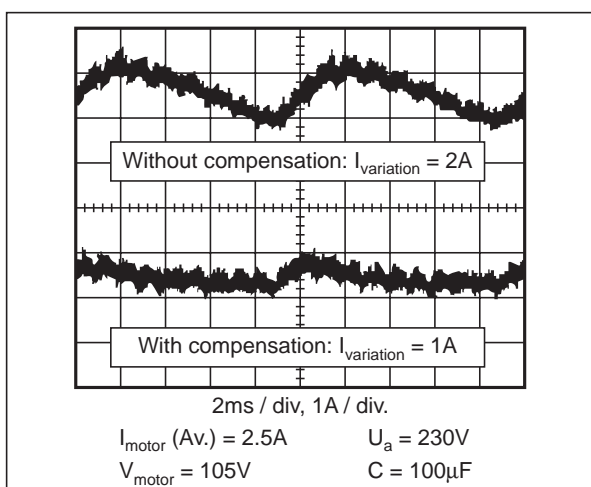

Figure 7. Dynamic performance of the voltage compensation



almost insensitive to the input power and mains voltage variations.

Figure 7 shows the dynamic influence of compensation on motor current ripple. The ripple is reduced by a factor of two in normal operation.

Motor power limitation is performed by measuring the peak motor current  $I_p$  using a resistor or a SENSEFET. With a capacitor, diode, and the sample-and-hold method this measurement is easy and accurate (see figure 8).

The motor power limitation aims to limit  $d$  to a maximum duty cycle  $d_{max}$ . Assuming that the motor current  $I_{mot}$  is almost constant,  $d_{max}$  is defined as a hyperbolic function of  $U_d$  and  $I_{mot}$  (see figure 9) :

$$P_{mot} = I_{mot} \times V_{mot} = I_{mot} \times U_d \times d$$

$$\frac{P_{mot}}{P_{max}}$$

$$d < d_{max} = \frac{P_{max}}{U_d \times I_{mot}}$$

$d_{max}$  is taken from a look-up table versus  $U_d$  and  $I_{mot}$  which are measured and quantized in 16 and 32 steps respectively. Power limitation needs a table of 512 bytes, and is performed every 3ms. Figure 10 shows the result with 300W limitation.

The two look-up tables are computed using a high level language program or by hand in order to avoid calculation in the CPU, speeding up the process. The tables used in this example are suitable for 230V or 120V mains applications.

The compensation and limitation tables can be modified and optimized to special requirements.

The accuracy of results is mainly governed by the resolution of the ADC (20 mV) and the basic step of converted measures ( $1/2^n$  for  $n \leq 8$ ).

#### 4. THE SWITCH : THE POWER ACTUATOR OF THE MOTOR CONTROL

Insulated gate transistors like Insulated Gate Bipolar Transistors (IGBTs) or Power MOSFET transistors are usually used for this purpose. Such transistors simplify and improve the chopper design because :

- their gate driver is simple: they are controlled by connecting a 15V voltage source to the transistor gate ;
- they are fast: the switching frequency can be made high enough to be inaudible (up to 16 kHz) because of their low turn-off energy.

The interface between the MCU and the switching

**Figure 8. Peak motor current sensing:**

- a) Operation is independent of switching; measurement is made when T<sub>1</sub> is OFF, analogue value is reset when T<sub>1</sub> turns on.
- b) Block diagram.

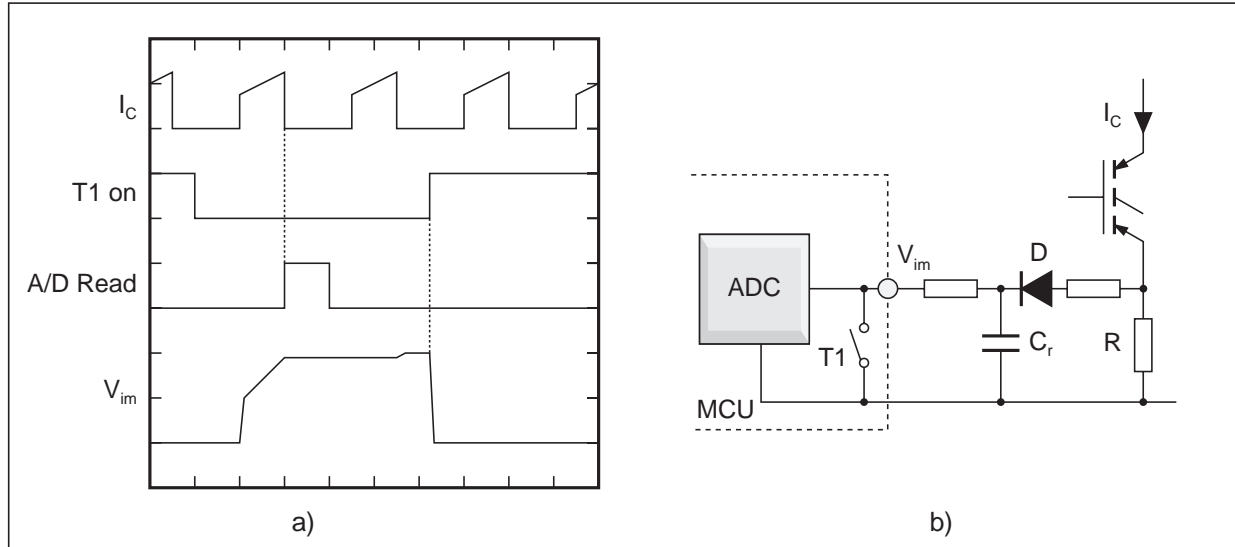

**Figure 9. Motor power limitation.**

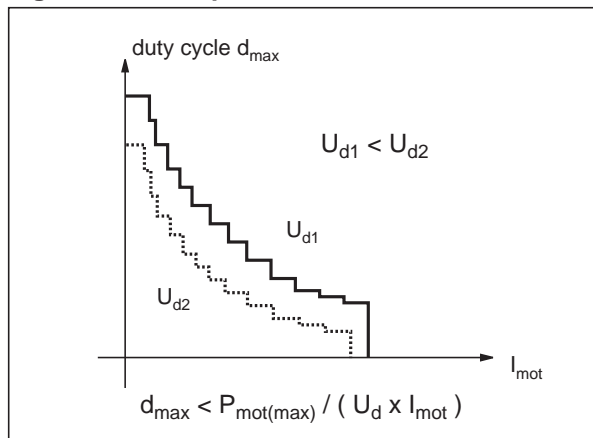

**Figure 10. Motor power limitation performance.**

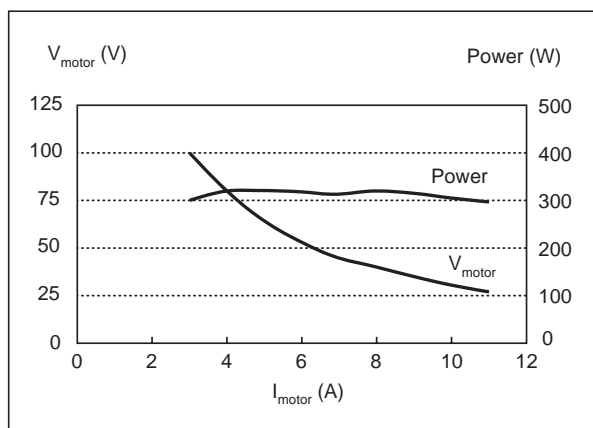

transistor is made by a 15V auxiliary supply that is connected to the 350V DC supply, and by a buffer-amplifier that is driven directly by the PWM timer output. To this basic driver we can add other functions (see figure 11) :

- A transistor current sensor (necessary for power limitation). A resistor or a SENSEFET can be used with an analog peak current detector (capacitance and diode).

**Figure 11. Basic diagram of the MCU-switch interface. Fast transistor protection could be added to the driver functions.**

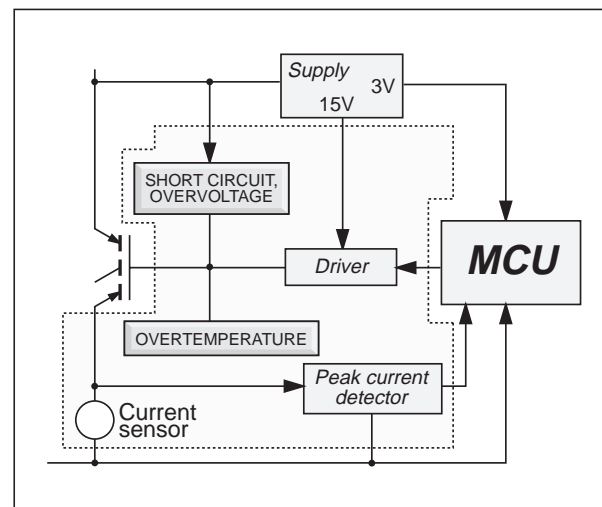

## APPLICATION NOTE

---

- Some fast transistor protection. The MCU cannot generally assume that the protection is present, because its reaction time is slower (12 $\mu$ s typ.) than required response time (less than 1 $\mu$ s). With its own protection the transistor immunity is increased. Short circuit, overvoltage and overtemperature protection are the most important types of protection for good functional safety.

### CONCLUSION

The design presented proposes a kit “microcontroller plus IGBT” that meets all requirements for controlling a permanent magnet DC motor in home appliances or industrial applications.

This kit reduces the components count on the board because the microcontroller can integrate in one package all the functions of interface and motor control.

The MCU + IGBT becomes a flexible and adaptable solution for power control. The switching transistor can be changed, and therefore the motor power, up to about 4 kW. The motor control software can be modified (speed regulation, current compensation) to include other functions (bus interfacing, heating, power supply control).

### REFERENCES

- i) MICROCONTROLLER AND TRIAC ON 120/230V MAINS  
AN392/A, P. RABIER and L. PERIER (SGS-THOMSON Microelectronics).
- ii) DESIGN WITH MICROCONTROLLERS IN NOISY ENVIRONMENT  
AN435, L. PERIER (SGS-THOMSON Microelectronics).
- iii) FROM STANDARD TO INTELLIGENT MOSFET  
AN516, M. BILDGEN (SGS-THOMSON Microelectronics).
- iv) VERSATILE AND COST EFFECTIVE INDUCTION MOTOR DRIVE WITH DIGITAL THREE PHASE GENERATION  
AN424, B. MAURICE, J.M. BOURGEOIS, B. SABY (SGS-THOMSON Microelectronics).

Appendix 1. Comparison of AC universal motor and Permanent Magnet DC motor.

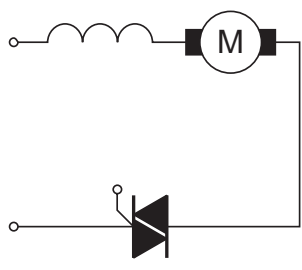
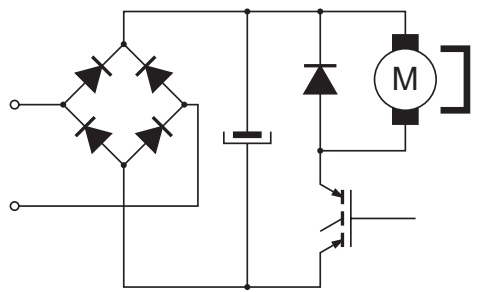
CRITERIA	AC UNIVERSAL MOTOR	PERMANENT MAGNET DC MOTOR
Driver	Single triac	Rectifier bridge+ chopper Simple transistor driver
Speed range (RPM)	1000 —> 25000	100 —> 25000
Speed control	Runaway if no load	Closed loop speed regulation is necessary if large torque variation
Torque capability at low speed	High, but needs control loop	Natural nominal torque
Motor efficiency	40-50%	60-70%
Motor losses	50Hz copper and iron losses	No excitation losses
Driver losses	Lower (TRIAC)	Higher (rectifier + chopper)
Noise	Higher 100Hz torque ripple, brushes commutation	Motor control reduces torque ripple, inaudible switching frequency brushes commutation.
Magnetization	Sensitive to iron saturation	Overcurrent and overtemperature can demagnetize permanent magnets
Basic Diagram		

# APPLICATION NOTE

## Appendix 2. Complete diagram of the Permanent Magnet DC motor drive with ST6265 microcontroller, STGP10N50 IGBT transistor and STTA806DI diode.

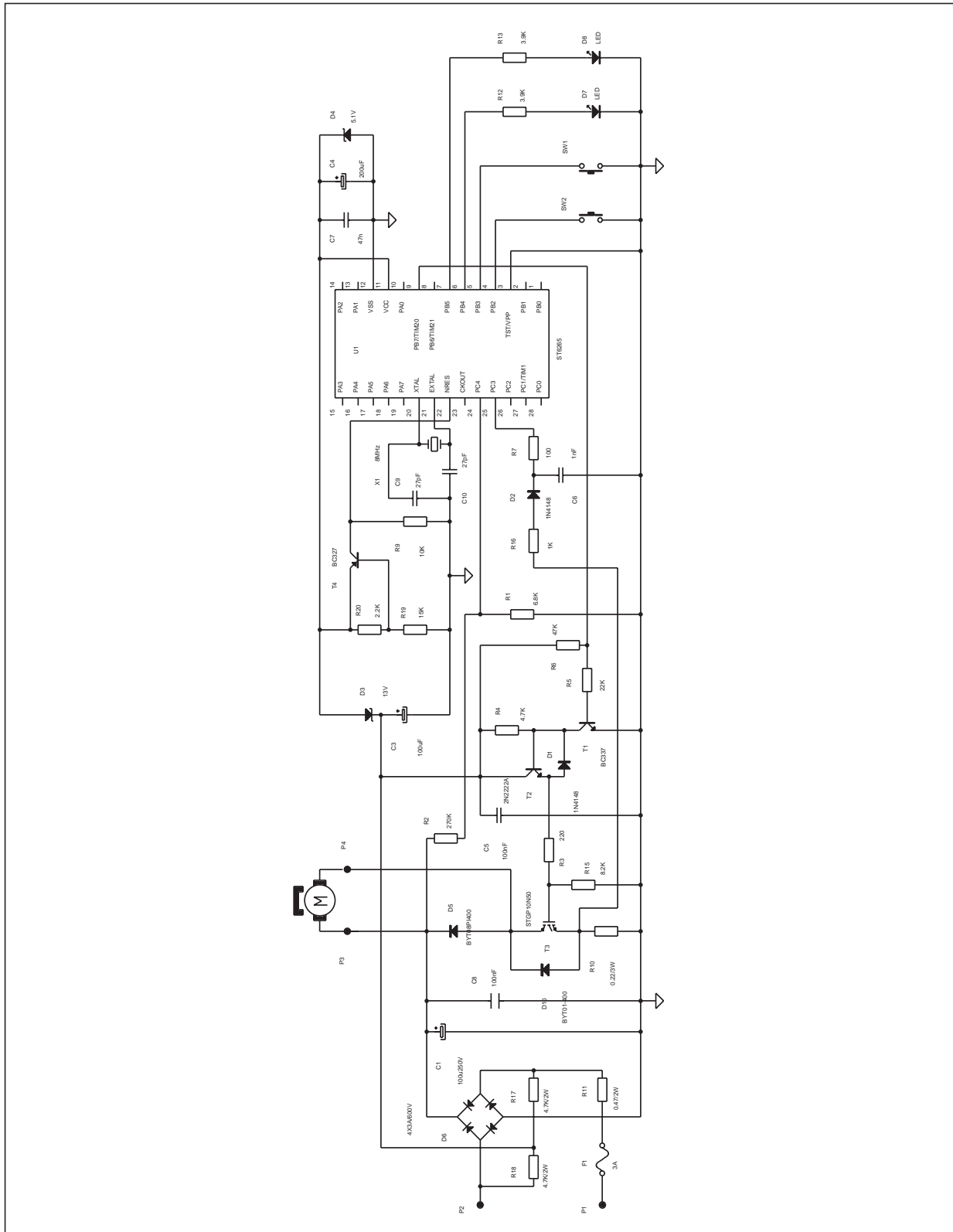



Information furnished is believed to be accurate and reliable. However, STMicroelectronics assumes no responsibility for the consequences of use of such information nor for any infringement of patents or other rights of third parties which may result from its use. No license is granted by implication or otherwise under any patent or patent rights of STMicroelectronics. Specification mentioned in this publication are subject to change without notice. This publication supersedes and replaces all information previously supplied. STMicroelectronics products are not authorized for use as critical components in life support devices or systems without express written approval of STMicroelectronics.

The ST logo is a trademark of STMicroelectronics

© 1999 STMicroelectronics - Printed in Italy - All Rights Reserved

STMicroelectronics GROUP OF COMPANIES

Australia - Brazil - China - Finland - France - Germany - Hong Kong - India - Italy - Japan - Malaysia - Malta - Morocco -  
Singapore - Spain - Sweden - Switzerland - United Kingdom - U.S.A.

<http://www.st.com>