

NEC

MOS INTEGRATED CIRCUIT

μ PD78052Y, 78053Y, 78054Y, 78055Y, 78056Y, 78058Y

8-BIT SINGLE-CHIP MICROCONTROLLER

DESCRIPTION

The μ PD78052Y, 78053Y, 78054Y, 78055Y, 78056Y, and 78058Y are the μ PD78054Y subseries products of the 78K/0 series.

Various peripheral hardware such as 8-bit resolution D/A converter, timer, serial interface (I²C bus mode compatible), real-time output port and interrupt functions are incorporated.

The μ PD78P054Y, 78P058Y, a one-time PROM or EPROM version which can be operated in the same supply voltage range as for the mask ROM version, and various development tools are also available.

Detailed function descriptions, etc., are provided in the following User's Manual. Be sure to read it when designing.

μ PD78054, 78054Y Subseries User's Manual : IEU-1356

78K/0 Series User's Manual Instructions : IEU-1372

FEATURES

- Internal high-capacity ROM and RAM

Part number	Item	Program memory (ROM)	Data memory		
			Internal High-Speed RAM	Buffer RAM	Internal Expanded RAM
μ PD78052Y		16 Kbytes	512 bytes	32 bytes	No
μ PD78053Y		24 Kbytes	1024 bytes		
μ PD78054Y		32 Kbytes			
μ PD78055Y		40 Kbytes			
μ PD78056Y		48 Kbytes			
μ PD78058Y		60 Kbytes		1024 bytes	

- External memory expansion space : 64 Kbytes
- Instruction execution time can be varied from high-speed (0.4 μ s) to ultra-low-speed (122 μ s)
- I/O ports : 69 (N-ch open-drain : 4)
- 8-bit resolution A/D converter: 8 channels
- 8-bit resolution D/A converter: 2 channels
- Serial interface : 3 channels (I²C bus mode : 1 channel)
- Timer : 5 channels
- Supply voltage : V_{DD} = 2.0 to 6.0 V

APPLICATIONS

Cellular phones, pagers, printers, AV equipment, airconditioners, cameras, PPC, fuzzy home appliances, vending machines, etc.

The information in this document is subject to change without notice.

ORDERING INFORMATION

Part Number	Package
μPD78052YGC-xxx-3B9	80-pin plastic QFP (14 x 14 mm)
μPD78053YGC-xxx-3B9	80-pin plastic QFP (14 x 14 mm)
μPD78054YGC-xxx-3B9	80-pin plastic QFP (14 x 14 mm)
μPD78055YGC-xxx-3B9	80-pin plastic QFP (14 x 14 mm)
μPD78056YGC-xxx-3B9	80-pin plastic QFP (14 x 14 mm)
μPD78058YGC-xxx-3B9	80-pin plastic QFP (14 x 14 mm)

Remark xxx indicates the ROM code suffix.

78K/0 SERIES PRODUCT DEVELOPMENT

The following shows the products of the 78K/0 Series. The designations appearing inside the boxes are subseries names.

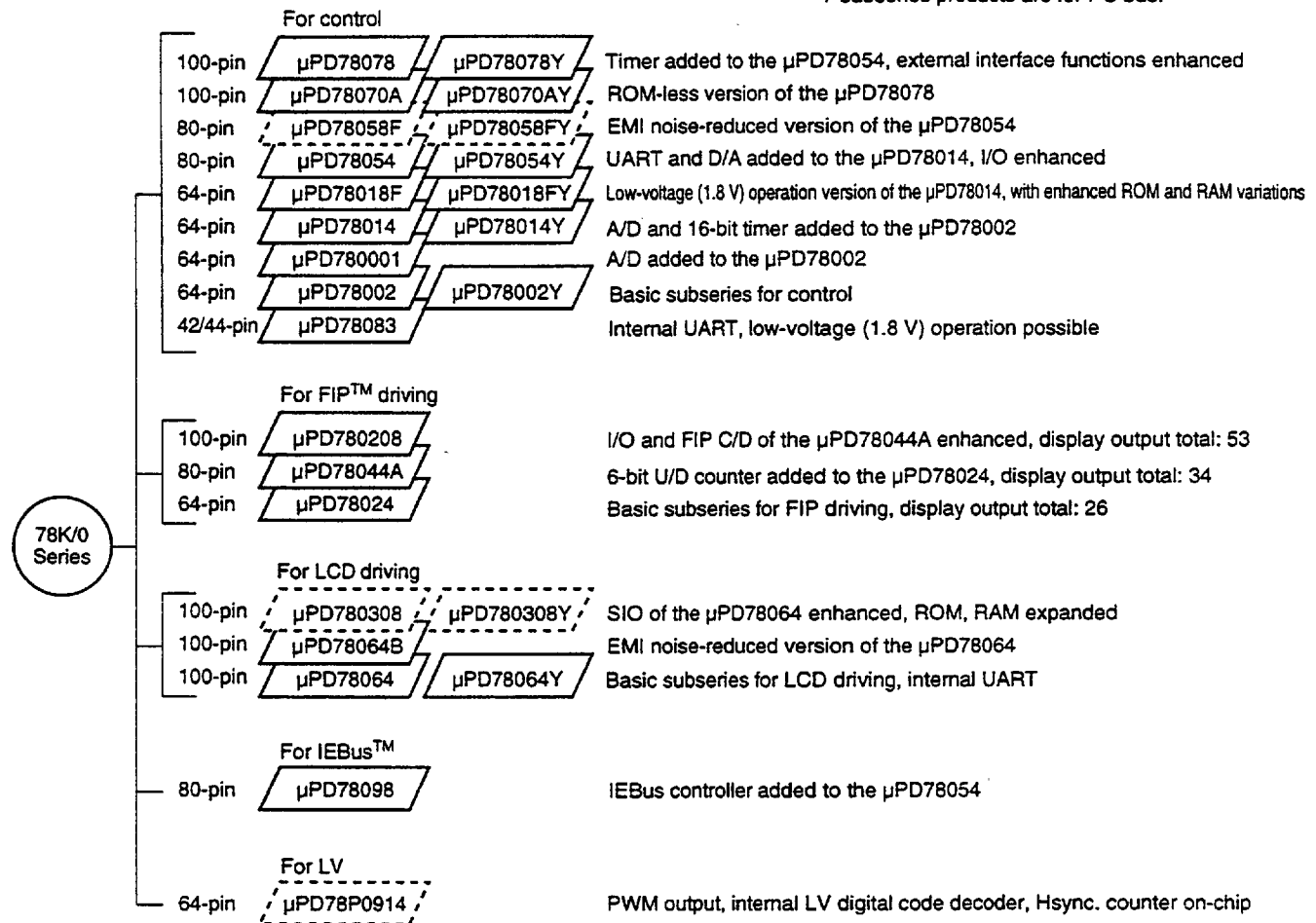
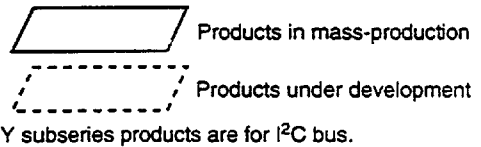

The major functional differences among the subseries are shown below.

Name	Function	ROM	Timer				8-bit A/D	8-bit D/A	Serial Interface	I/O	V _{DD} MIN. Value	External Expansion
			8-bit	16-bit	Watch	WDT						
For control	μPD78078	32 K to 60 K	4 ch	1 ch	1 ch	1 ch	8 ch	2 ch	3 ch (UART : 1 ch)	88	1.8 V	√
	μPD78070A	-								61	2.7 V	
	μPD78058F	48 K to 60 K	2 ch	69	2.0 V							
	μPD78054	16 K to 60 K		-	2 ch	53	1.8 V					
	μPD78018F	8 K to 60 K				53	2.7 V					
	μPD78014	8 K to 32 K	-	-	-	-	1 ch	39	-			
	μPD780001	8 K						53	√			
	μPD78002	8 K to 16 K						8 ch	1 ch (UART : 1 ch)	33	1.8 V	-
	For FIP driving	μPD780208	32 K to 60 K	2 ch	1 ch	1 ch	1 ch	8 ch	-	2 ch	74	2.7 V
μPD78044A		16 K to 40 K	68									
μPD78024		24 K to 32 K	54									
For LCD driving	μPD780308	48 K to 60 K	2 ch	1 ch	1 ch	1 ch	8 ch	-	3 ch (UART : 1 ch)	57	1.8 V	-
	μPD78064B	32 K							2 ch (UART : 1 ch)	2.0 V		
	μPD78064	16 K to 32 K										
For IEBus	μPD78098	32 K to 60 K	2 ch	1 ch	1 ch	1 ch	8 ch	2 ch	3 ch (UART : 1 ch)	69	2.7 V	√
For LV	μPD78P0914	32 K	6 ch	-	-	1 ch	8 ch	-	2 ch	54	4.5 V	√

FUNCTIONAL OVERVIEW

Item		Product Name					
		μPD78052Y	μPD78053Y	μPD78054Y	μPD78055Y	μPD78056Y	μPD78058Y
Internal memory	ROM	16 Kbytes	24 Kbytes	32 Kbytes	40 Kbytes	48 Kbytes	60 Kbytes
	Internal high-speed RAM	512 bytes	1024 bytes				
	Buffer RAM	32 bytes					
	Internal expanded RAM	None					1024 bytes
Memory space		64 Kbytes					
General registers		8 bits x 32 registers (8 bits x 8 registers x 4 banks)					
Instruction cycle		On-chip instruction execution time cycle modification function					
	When main system clock selected	0.4 μs/0.8 μs/1.6 μs/3.2 μs/6.4 μs/12.8 μs (@ 5.0-MHz operation)					
	When subsystem clock selected	122 μs (@ 32.768-kHz operation)					
Instruction set		<ul style="list-style-type: none"> • 16-bit operation • Multiply/divide (8 bits x 8 bits, 16 bits + 8 bits) • Bit manipulate (set, reset, test, boolean operation) • BCD adjust, etc. 					
I/O ports		Total : 69 <ul style="list-style-type: none"> • CMOS input : 2 • CMOS I/O : 63 • N-ch open-drain I/O : 4 					
A/D converter		• 8-bit resolution x 8 channels					
D/A converter		• 8-bit resolution x 2 channels					
Serial interface		<ul style="list-style-type: none"> • 3-wire/2-wire/I²C bus mode selectable: 1 channel • 3-wire mode (on-chip max. 32 bytes automatic data transmit/receive function): 1 channel • 3-wire/UART mode selectable : 1 channel 					
Timer		<ul style="list-style-type: none"> • 16-bit timer/event counter : 1 channel • 8-bit timer/event counter : 2 channels • Watch timer : 1 channel • Watchdog timer : 1 channel 					
Timer output		3 (14-bit PWM output x 1)					
Clock output		19.5 kHz, 39.1 kHz, 78.1 kHz, 156 kHz, 313 kHz, 625 kHz, 1.25 MHz, 2.5 MHz, 5.0 MHz (@5.0-MHz operation with main system clock) 32.768 kHz (@32.768-kHz operation with subsystem clock)					
Buzzer output		1.2 kHz, 2.4 kHz, 4.9 kHz, 9.8 kHz (@5.0-MHz operation with main system clock)					
Vectored interrupts	Maskable interrupts	Internal interrupt : 13, external interrupt : 7					
	Non-maskable interrupts	Internal interrupt : 1					
	Software interrupts	Internal interrupt : 1					
Test input		Internal : 1, external : 1					
Power supply voltage		V _{DD} = 2.0 to 6.0 V					
Operating ambient temperature		T _A = -40 to +85 °C					
Package		80-pin plastic QFP (14 x 14 mm)					

CONTENTS

1.	PIN CONFIGURATION (TOP VIEW)	7
2.	BLOCK DIAGRAM	9
3.	PIN FUNCTIONS	10
3.1	PORT PINS	10
3.2	NON-PORT PINS	12
3.3	PIN I/O CIRCUITS AND RECOMMENDED CONNECTION OF UNUSED PINS	14
4.	MEMORY SPACE	18
5.	PERIPHERAL HARDWARE FUNCTION FEATURES	19
5.1	PORTS	19
5.2	CLOCK GENERATOR	20
5.3	TIMER/EVENT COUNTER	20
5.4	CLOCK OUTPUT CONTROL CIRCUIT	23
5.5	BUZZER OUTPUT CONTROL CIRCUIT	23
5.6	A/D CONVERTER	24
5.7	D/A CONVERTER	25
5.8	SERIAL INTERFACES	25
5.9	REAL-TIME OUTPUT PORT FUNCTIONS	27
6.	INTERRUPT FUNCTIONS AND TEST FUNCTIONS	28
6.1	INTERRUPT FUNCTIONS	28
6.2	TEST FUNCTIONS	32
7.	EXTERNAL DEVICE EXPANSION FUNCTIONS	33
8.	STANDBY FUNCTION	33
9.	RESET FUNCTION	33
10.	INSTRUCTION SET	34
★	11. ELECTRICAL SPECIFICATIONS	37
★	12. CHARACTERISTIC CURVES (REFERENCE VALUE)	65
	13. PACKAGE DRAWING	67
★	14. RECOMMENDED SOLDERING CONDITIONS	68
	APPENDIX A. DEVELOPMENT TOOLS	70
	APPENDIX B. RELATED DOCUMENTS	72

1. PIN CONFIGURATION (TOP VIEW)

• 80-pin plastic QFP (14 x 14 mm)

μPD78052YGC-xxx-3B9

μPD78053YGC-xxx-3B9

μPD78054YGC-xxx-3B9

μPD78055YGC-xxx-3B9

μPD78056YGC-xxx-3B9

μPD78058YGC-xxx-3B9

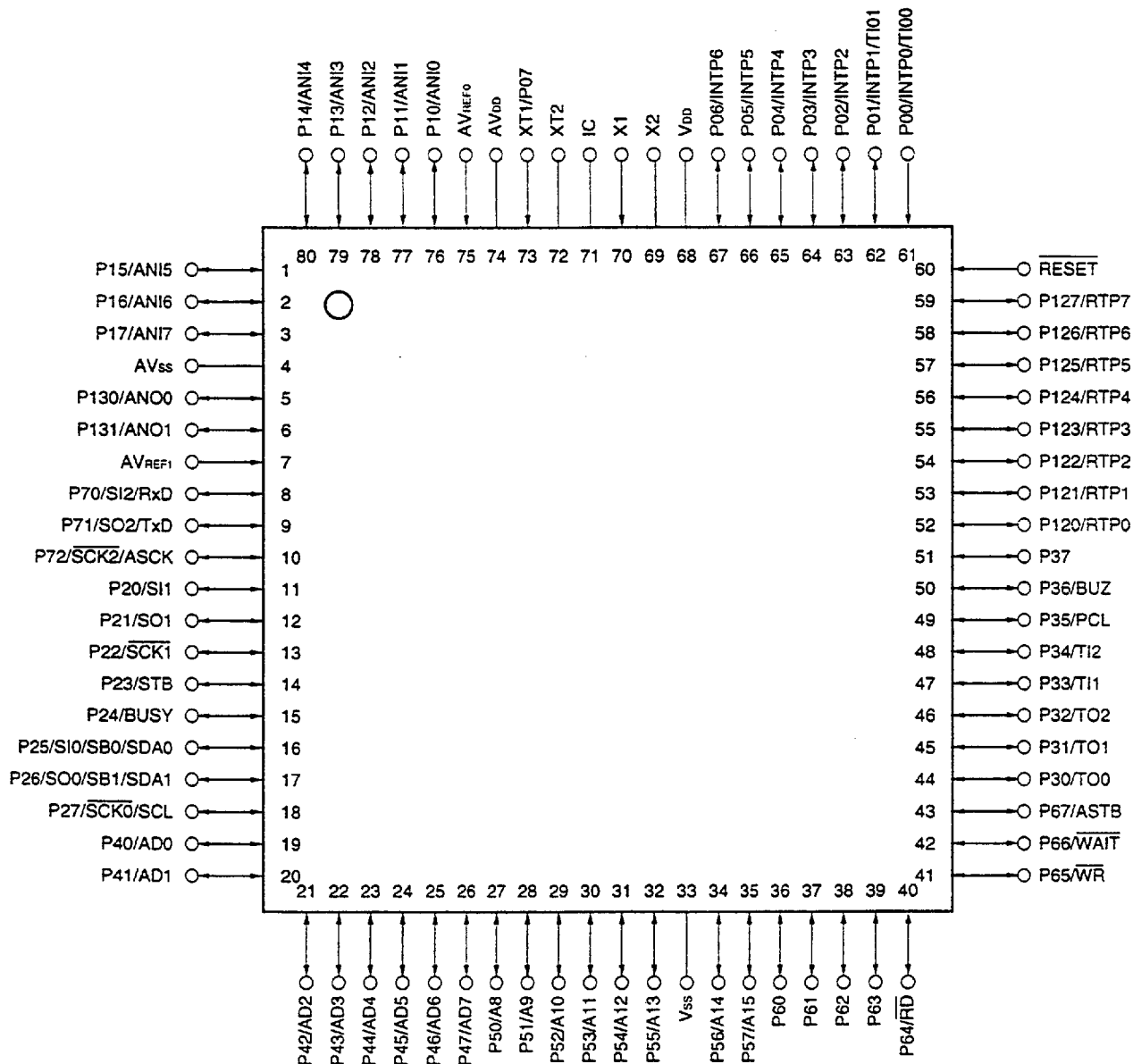

- Cautions**
1. IC (Internally Connected) pin should be connected directly to V_{ss}.
 2. AV_{DD} pin should be connected to V_{DD} pin.
 3. AV_{ss} pin should be connected to V_{ss} pin.

P00 to P07	: Port0	A $\overline{\text{SCK}}$: Asynchronous Serial Clock
P10 to P17	: Port1	PCL	: Programmable Clock
P20 to P27	: Port2	BUZ	: Buzzer Clock
P30 to P37	: Port3	STB	: Strobe
P40 to P47	: Port4	BUSY	: Busy
P50 to P57	: Port5	AD0 to AD7	: Address/Data Bus
P60 to P67	: Port6	A8 to A15	: Address Bus
P70 to P72	: Port7	$\overline{\text{RD}}$: Read Strobe
P120 to P127	: Port12	$\overline{\text{WR}}$: Write Strobe
P130, P131	: Port13	$\overline{\text{WAIT}}$: Wait
RTP0 to RTP7	: Real-Time Output Port	ASTB	: Address Strobe
INTP0 to INTP6	: Interrupt from Peripherals	X1, X2	: Crystal (Main System Clock)
TI00, TI01	: Timer Input	XT1, XT2	: Crystal (Subsystem Clock)
TI1, TI2	: Timer Input	$\overline{\text{RESET}}$: Reset
TO0 to TO2	: Timer Output	ANI0 to ANI7	: Analog Input
SB0, SB1	: Serial Bus	ANO0, ANO1	: Analog Output
SI0 to SI2	: Serial Input	AV $\overline{\text{DD}}$: Analog Power Supply
SO0 to SO2	: Serial Output	AV SS	: Analog Ground
$\overline{\text{SCK0}}$ to $\overline{\text{SCK2}}$: Serial Clock	AV $\overline{\text{REF0.1}}$: Analog Reference Voltage
SCL	: Serial Clock	V $\overline{\text{DD}}$: Power Supply
SDA0, SDA1	: Serial Data	V SS	: Ground
RxD	: Receive Data	IC	: Internally Connected
TxD	: Transmit Data		

2. BLOCK DIAGRAM

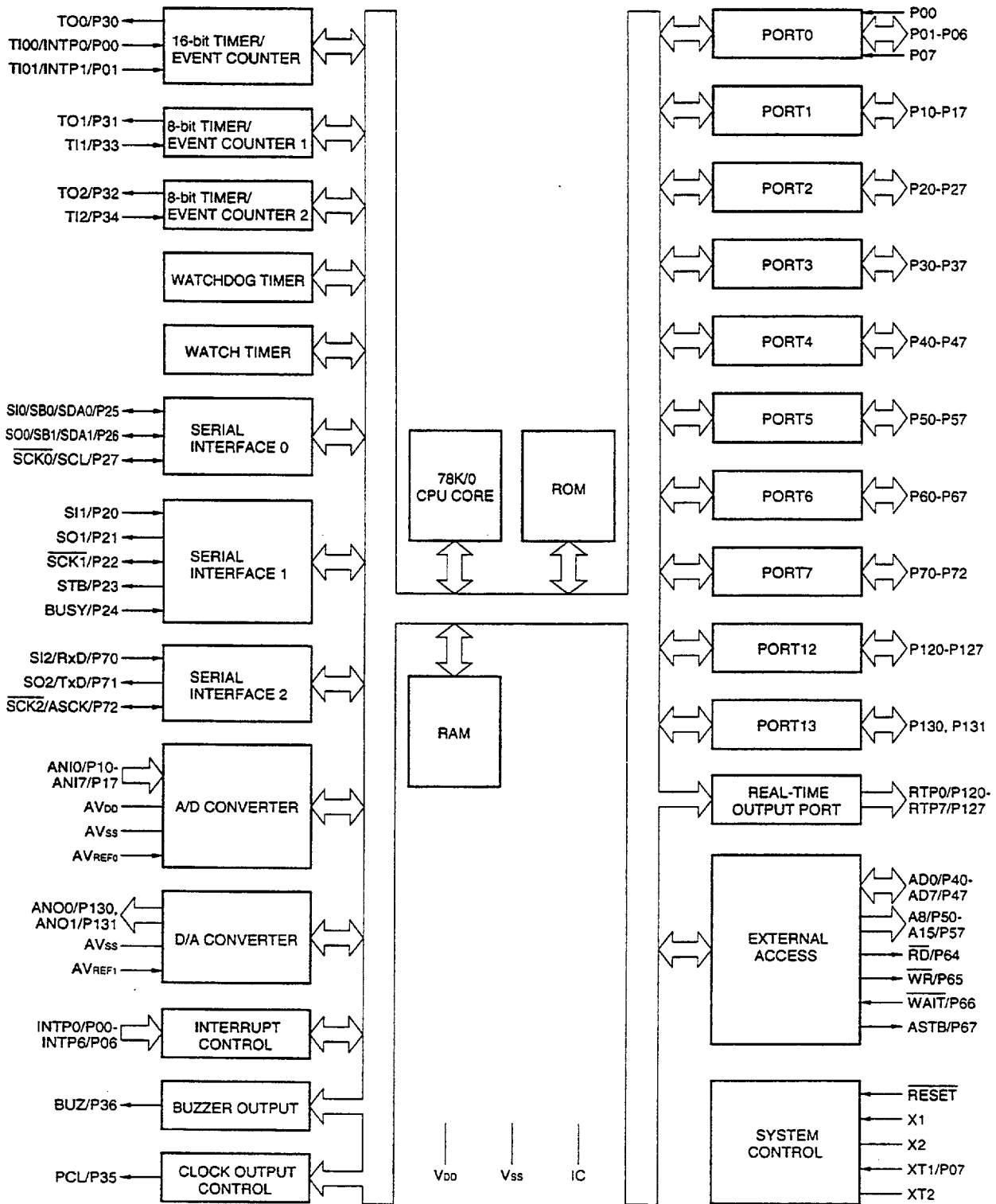

Remark The internal ROM and RAM capacity depends on the product.

3. PIN FUNCTIONS

3.1 PORT PINS (1/2)

Pin Name	I/O	Function		After Reset	Alternate Function
P00	Input	Port 0 8-bit I/O port	Input only	Input	INTP0/TI00
P01	Input/ output		Input/output can be specified bit-wise. When used as an input port, internal pull-up resistor can be connected by software.	Input	INTP1/TI01
P02					INTP2
P03					INTP3
P04					INTP4
P05					INTP5
P06					INTP6
P07 ^{Note 1}	Input		Input only	Input	XT1
P10 to P17	Input/ output	Port 1 8-bit input/output port. Input/output can be specified bit-wise. When used as an input port, internal pull-up resistor can be connected by software. ^{Note 2}		Input	ANI0 to ANI7
P20	Input/ output	Port 2 8-bit input/output port. Input/output can be specified bit-wise. When used as an input port, internal pull-up resistor can be connected by software.	Input	SI1	
P21				SO1	
P22				SCK1	
P23				STB	
P24				BUSY	
P25				SI0/SB0/SDA0	
P26				SO0/SB1/SDA1	
P27				SCK0/SCL	
P30	Input/ output	Port 3 8-bit input/output port. Input/output can be specified bit-wise. When used as an input port, internal pull-up resistor can be connected by software.	Input	TO0	
P31				TO1	
P32				TO2	
P33				TI1	
P34				TI2	
P35				PCL	
P36				BUZ	
P37				—	
P40 to P47	Input/ output	Port 4 8-bit input/output port. Input/output can be specified in 8-bit units. When used as an input port, internal pull-up resistor can be connected by software. Test input flag (KRIF) is set to 1 by falling edge detection.		Input	AD0 to AD7

- Notes**
1. When using the P07/XT1 pins as an input port, set 1 in bit 6 (FRC) of the processor clock control register (PCC). On-chip feedback resistor of the subsystem clock oscillator should not be used.
 2. When using the P10/ANI0 to P17/ANI7 pins as the A/D converter analog input pins, the pull-up resistor is disabled automatically.

3.1 PORT PINS (2/2)

Pin Name	I/O	Function		After Reset	Alternate Function
P50 to P57	Input/output	Port 5 8-bit input/output port. LEDs can be driven directly. Input/output can be specified bit-wise. When used as an input port, internal pull-up resistor can be connected by software.		Input	A8 to A15
P60	Input/output	Port 6 8-bit input/output port. Input/output can be specified bit-wise.	N-ch open-drain input/output port. On-chip pull-up resistor can be specified by mask option. LEDs can be driven directly.	Input	—
P61					
P62					
P63					
P64			When used as an input port, internal pull-up resistor can be connected by software.	Input	\overline{RD}
P65					\overline{WR}
P66					\overline{WAIT}
P67					ASTB
P70	Input/output	Port 7 3-bit input/output port. Input/output can be specified bit-wise. When used as an input port, internal pull-up resistor can be connected by software.	Input	SI2/RxD	
P71				SO2/TxD	
P72				$\overline{SCK2/ASCK}$	
P120 to P127	Input/output	Port 12 8-bit input/output port. Input/output can be specified bit-wise. When used as an input port, internal pull-up resistor can be connected by software.		Input	RTP0 to RTP7
P130, P131	Input/output	Port 13 2-bit input/output port. Input/output can be specified bit-wise. When used as an input port, internal pull-up resistor can be connected by software.		Input	ANO0, ANO1

3.2 NON-PORT PINS (1/2)

Pin Name	I/O	Function	After Reset	Alternate Function
INTP0	Input	External interrupt input by which the effective edge (rising edge, falling edge, or both rising edge and falling edge) can be specified.	Input	P00/TI00
INTP1				P01/TI01
INTP2				P02
INTP3				P03
INTP4				P04
INTP5				P05
INTP6				P06
SI0	Input	Serial interface serial data input.	Input	P25/SB0/SDA0
SI1				P20
SI2				P70/RxD
SO0	Output	Serial interface serial data output.	Input	P26/SB1/SDA1
SO1				P21
SO2				P71/TxD
SB0	Input /output	Serial interface serial data input/output.	Input	P25/SI0/SDA0
SB1				P26/SO0/SDA1
SDA0				P25/SI0/SB0
SDA1				P26/SO0/SB1
$\overline{\text{SCK0}}$	Input /output	Serial interface serial clock input/output	Input	P27/SCL
$\overline{\text{SCK1}}$				P22
$\overline{\text{SCK2}}$				P72/ASCK
SCL				P27/ $\overline{\text{SCK0}}$
STB	Output	Serial interface automatic transmit/receive strobe output.	Input	P23
BUSY	Input	Serial interface automatic transmit/receive busy input.	Input	P24
RxD	Input	Asynchronous serial interface serial data input.	Input	P70/SI2
TxD	Output	Asynchronous serial interface serial data output.	Input	P71/SO2
ASCK	Input	Asynchronous serial interface serial clock input.	Input	P72/ $\overline{\text{SCK2}}$
TI00	Input	External count clock input to the 16-bit timer (TM0)	Input	P00/INTP0
TI01		Capture trigger signal input to the capture register (CR00)		P01/INTP1
TI1		External count clock input to the 8-bit timer (TM1)		P33
TI2		External count clock input to the 8-bit timer (TM2)		P34
TO0	Output	16-bit timer output (dual-function as 14-bit PWM output)	Input	P30
TO1		8-bit timer output		P31
TO2		P32		
PCL	Output	Clock output (for main system clock, subsystem clock trimming).	Input	P35
BUZ	Output	Buzzer output.	Input	P36
RTP0 to RTP7	Output	Real-time output port by which data is output in synchronization with a trigger.	Input	P120 to P127
AD0 to AD7	Input /output	Low-order address/data bus at external memory expansion.	Input	P40 to P47

3.2 NON-PORT PINS (2/2)

Pin Name	I/O	Function	After Reset	Alternate Function
A8 to A15	Output	High-order address bus at external memory expansion.	Input	P50 to P57
\overline{RD}	Output	External memory read operation strobe signal output.	Input	P64
\overline{WR}		External memory write operation strobe signal output.		P65
\overline{WAIT}	Input	Wait insertion at external memory access.	Input	P66
ASTB	Output	Strobe output which latches the address information output at port 4 and port 5 to access external memory.	Input	P67
ANI0 to ANI7	Input	A/D converter analog input.	Input	P10 to P17
ANO0, ANO1	Output	D/A converter analog output.	Input	P130, P131
AVREF0	Input	A/D converter reference voltage input.	—	—
AVREF1	Input	D/A converter reference voltage input.	—	—
AVDD	—	A/D converter analog power supply. Connected to V _{DD}	—	—
AVSS	—	A/D converter ground potential. Connected to V _{SS}	—	—
\overline{RESET}	Input	System reset input.	—	—
X1	Input	Main system clock oscillation crystal connection.	—	—
X2	—		—	—
XT1	Input	Subsystem clock oscillation crystal connection.	Input	P07
XT2	—		—	—
V _{DD}	—	Positive power supply.	—	—
V _{SS}	—	Ground potential.	—	—
IC	—	Internal connection. Connect to V _{SS} directly.	—	—

★ 3.3 PIN I/O CIRCUITS AND RECOMMENDED CONNECTION OF UNUSED PINS

The input/output circuit type of each pin and recommended connection of unused pins are shown in Table 3-1. For the input/output circuit configuration of each type, see Figure 3-1.

Table 3-1. Input/Output Circuit Type of Each Pin (1/2)

Pin Name	Input/output Circuit Type	I/O	Recommended Connection when Not Used	
P00/INTP0/TI00	2	Input	Connected to Vss.	
P01/INTP1/TI01	8-A	Input/output	Independently connected to Vss through resistor.	
P02/INTP2				
P03/INTP3				
P04/INTP4				
P05/INTP5				
P06/INTP6				
P07/XT1	16	Input	Connected to V _{DD} .	
P10/ANI0 to P17/ANI7	11	Input/output	Independently connected to V _{DD} or V _{SS} through resistor.	
P20/SI1	8-A			
P21/SO1	5-A			
P22/SCK1	8-A			
P23/STB	5-A			
P24/BUSY	8-A			
P25/SI0/SB0/SDA0	10-A			
P26/SO0/SB1/SDA1				
P27/SCK0/SCL				
P30/TO0	5-A			
P31/TO1				
P32/TO2				
P33/TI1	8-A			
P34/TI2				
P35/PCL	5-A			
P36/BUZ				
P37				
P40/AD0 to P47/AD7	5-E			Independently connected to V _{DD} through resistor.
P50/A8 to P57/A15	5-A			Independently connected to V _{DD} or V _{SS} through resistor.
P60 to P63	13-B			Independently connected to V _{DD} through resistor.
P64/RD	5-A			Independently connected to V _{DD} or V _{SS} through resistor.
P65/WR				
P66/WAIT				
P67/ASTB				

Table 3-1. Input/Output Circuit Type of Each Pin (2/2)

Pin Name	Input/output Circuit Type	I/O	Recommended Connection when Not Used
P70/SI2/RxD	8-A	Input/output	Independently connected to V _{DD} or V _{SS} through resistor.
P71/SO2/TxD	5-A		
P72/SCK2/ASCK	8-A		
P120/RTP0 to P127/RTP7	5-A		
P130/ANO0, P131/ANO1	12-A		
RESET	2	Input	—
XT2	16	—	Leave open.
AVREF0	—		Connected to V _{SS} .
AVREF1			Connected to V _{DD} .
AVDD			
AVSS			Connected to V _{SS} .
IC			Connected to V _{SS} directly.

Figure 3-1. Pin Input/Output Circuits (1/2)

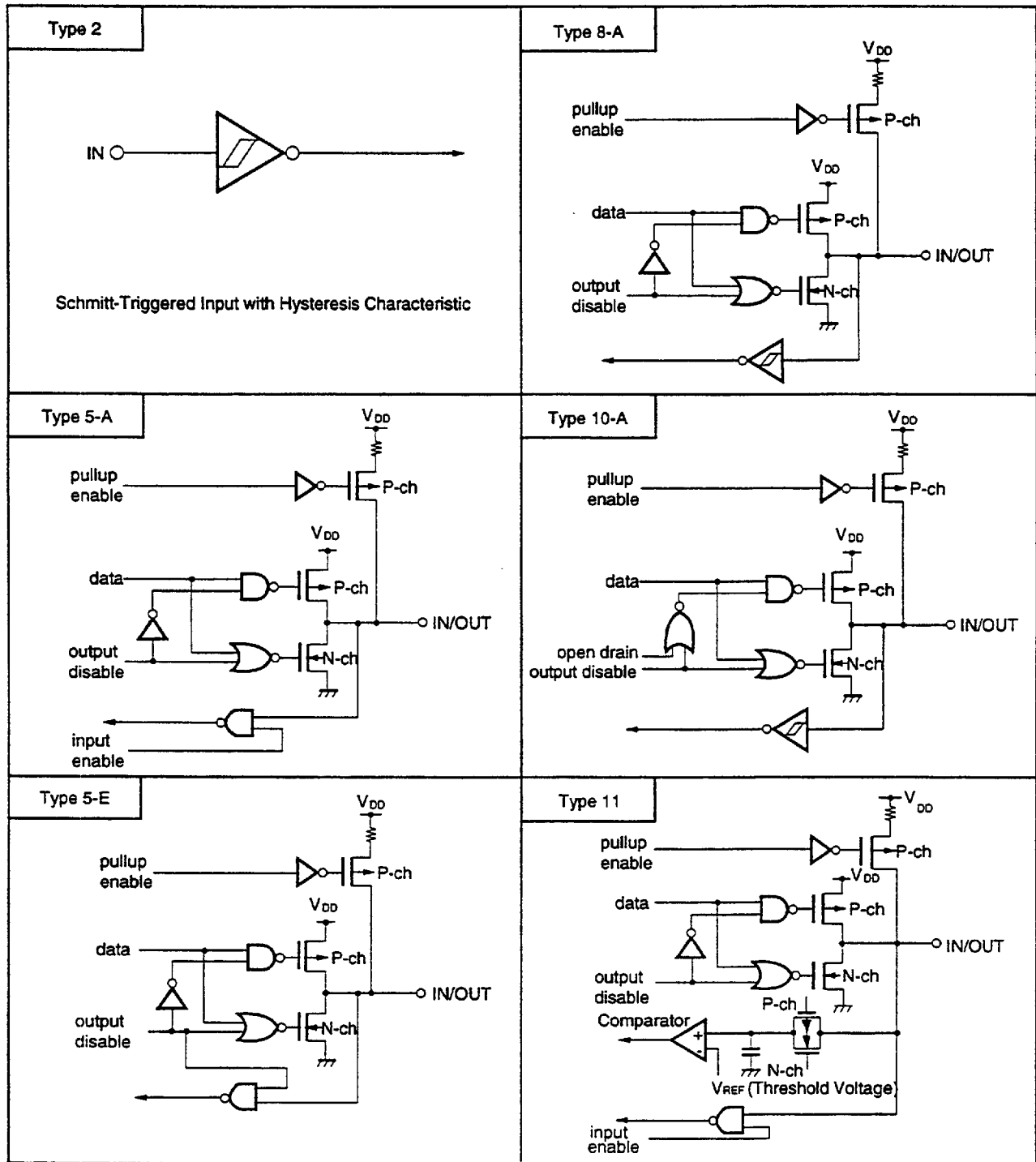
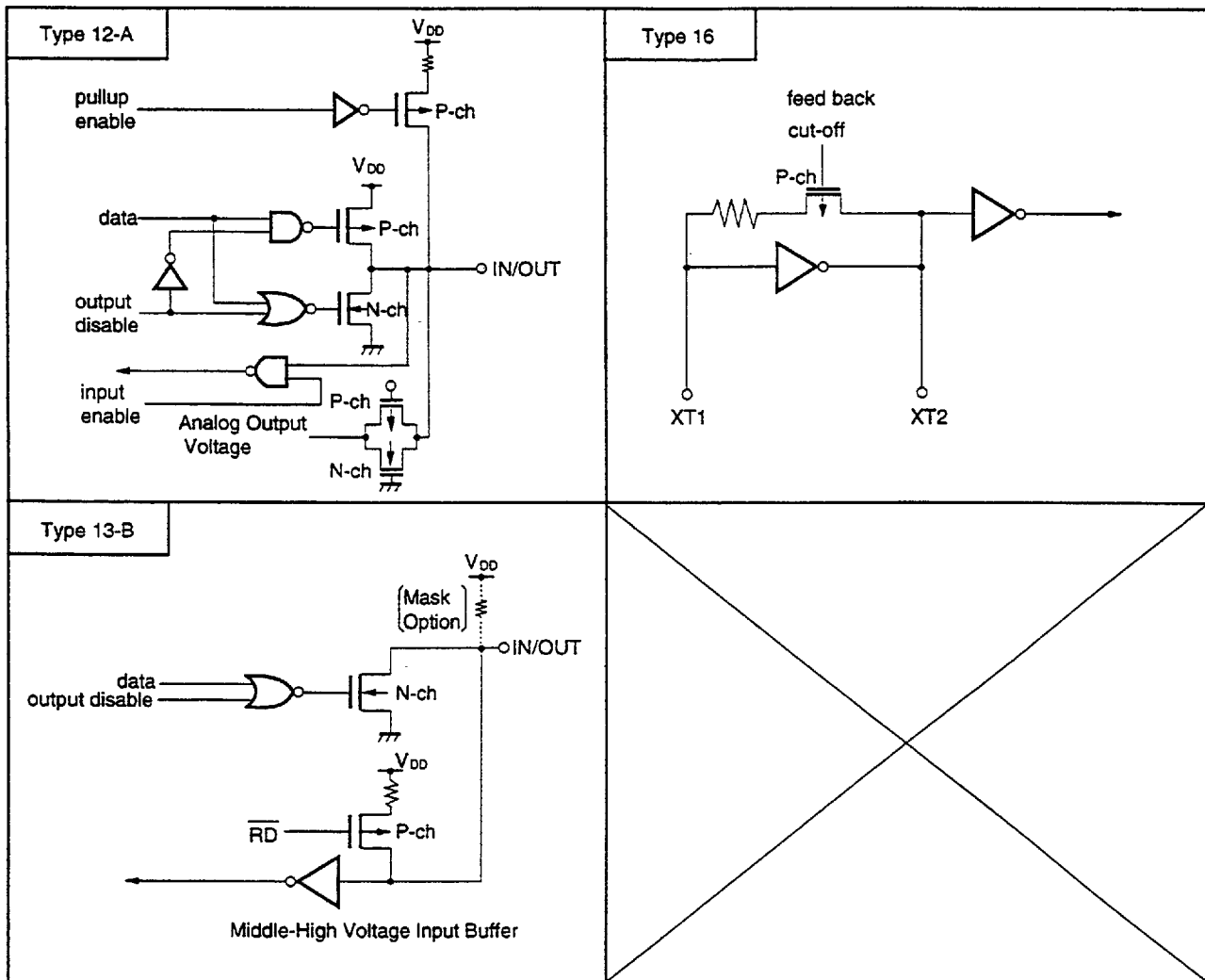

Figure 3-1. Pin Input/Output Circuits (2/2)



4. MEMORY SPACE

Figure 4-1 shows the μPD78052Y/78053Y/78054Y/78055Y/78056Y/78058Y memory map.

Figure 4-1. Memory Map

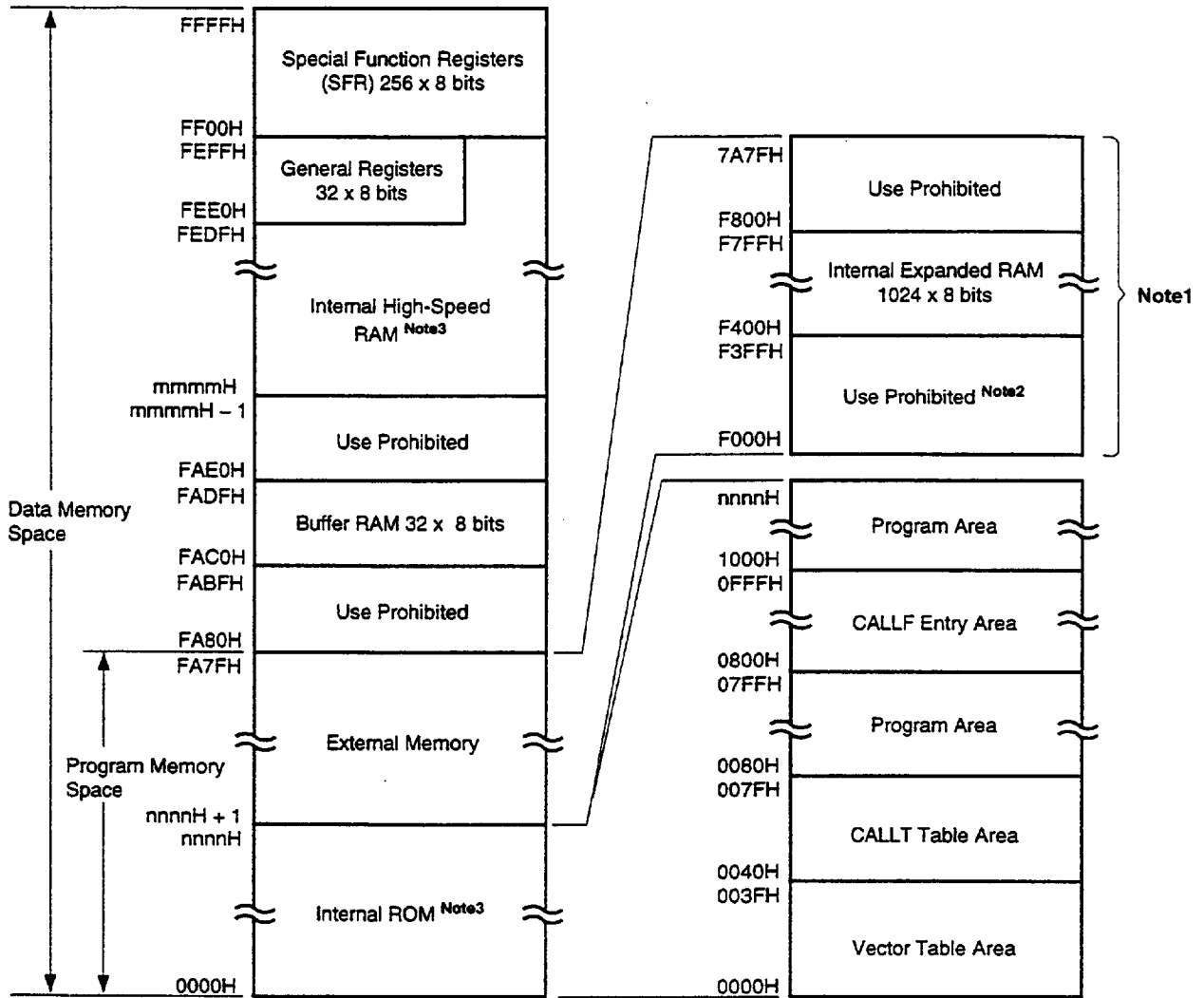

Notes 1. Provided in the μPD78058Y only

2. When the external device expansion function is used with the μPD78058Y, set the internal ROM capacity to 56 Kbytes or less using the internal memory size switching register (IMS).

3. The internal ROM capacity and internal high-speed RAM capacity depend on the products (see the next table).

Relevant Product Name	Internal ROM Last Address nnnnH	Internal High-Speed RAM First Address mmmmH
μPD78052Y	3FFFH	FD00H
μPD78053Y	5FFFH	FB00H
μPD78054Y	7FFFH	
μPD78055Y	9FFFH	
μPD78056Y	BFFFH	
μPD78058Y	EFFFH	

5. PERIPHERAL HARDWARE FUNCTION FEATURES

5.1 PORTS

The following 3 types of I/O ports are available.

• CMOS input (P00, P07)	: 2
• CMOS input/output (P01 to P06, port 1 to port 5, P64 to P67, port 7, port 12, port 13)	: 63
• N-channel open-drain input/output (P60 to P63)	: 4
Total	: 69

Table 5-1. Port Functions

Name	Pin Name	Function
Port 0	P00, P07	Dedicated input port pins
	P01 to P06	Input/output port pins. Input/output specifiable bit-wise. When used as input/output port pins, on-chip pull-up resistor can be connected by software.
Port 1	P10 to P17	Input/output port pins. Input/output specifiable bit-wise. When used as input port pins, on-chip pull-up resistor can be connected by software.
Port 2	P20 to P27	Input/output port pins. Input/output specifiable bit-wise. When used as input port pins, on-chip pull-up resistor can be connected by software.
Port 3	P30 to P37	Input/output port pins. Input/output specifiable bit-wise. When used as input port pins, on-chip pull-up resistor can be connected by software.
Port 4	P40 to P47	Input/output port pins. Input/output specifiable in 8-bit units. When used as input port pins, on-chip pull-up resistor can be connected by software. Test input flag (KRIF) is set to 1 by falling edge detection.
Port 5	P50 to P57	Input/output port pins. Input/output specifiable bit-wise. When used as input port pins, on-chip pull-up resistor can be connected by software. LEDs direct drive capability.
Port 6	P60 to P63	N-channel open-drain input/output port pins. Input/output specifiable bit-wise. On-chip pull-up resistor can be connected by mask option. LEDs direct drive capability.
	P64 to P67	Input/output port pins. Input/output specifiable bit-wise. When used as input/output port pins, on-chip pull-up resistor can be connected by software.
Port 7	P70 to P72	Input/output port pins. Input/output specifiable bit-wise. When used as input/output port pins, on-chip pull-up resistor can be connected by software.
Port 12	P120 to P127	Input/output port pins. Input/output specifiable bit-wise. When used as input/output port pins, on-chip pull-up resistor can be connected by software.
Port 13	P130, P131	Input/output port pins. Input/output specifiable bit-wise. When used as input/output port pins, on-chip pull-up resistor can be connected by software.

5.2 CLOCK GENERATOR

Two types of generators, a main system clock generator and a subsystem clock generator, are available. The instruction execution time can also be changed.

- 0.4 μs/0.8 μs/1.6 μs/3.2 μs/6.4 μs/12.8 μs (@5.0-MHz operation with main system clock)
- 122 μs (@32.768-kHz operation with subsystem clock)

Figure 5-1. Clock Generator Block Diagram

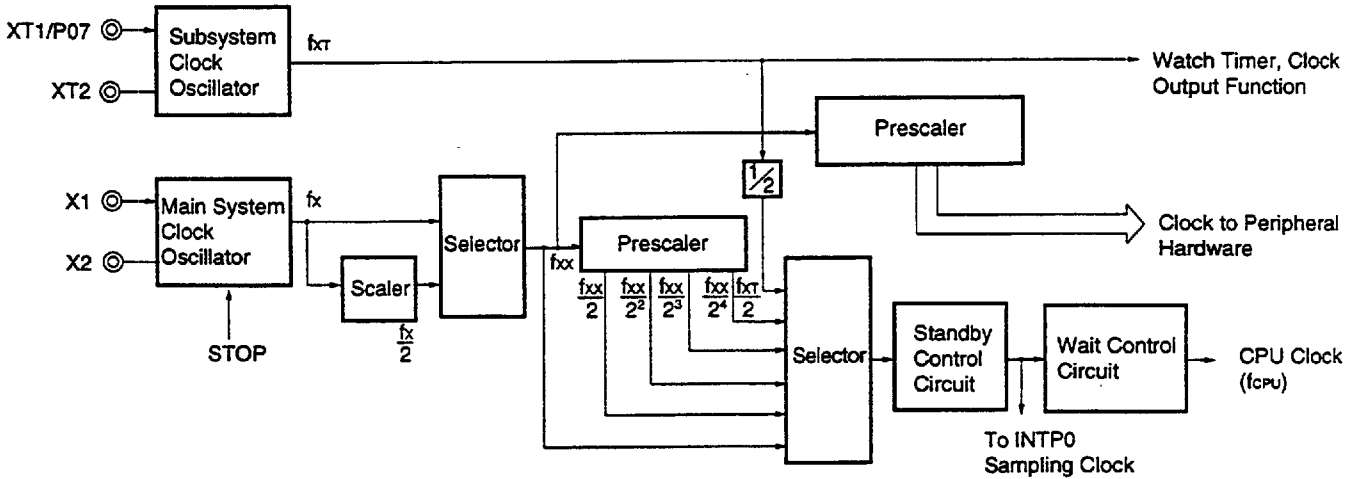

5.3 TIMER/EVENT COUNTER

5 timer/event counter channels are incorporated.

- 16-bit timer/event counter : 1 channel
- 8-bit timer/event counter : 2 channels
- Watch timer : 1 channel
- Watchdog timer : 1 channel

Table 5-2. Types and Functions of Timer/Event Counter

	16-Bit Timer/Event Counter	8-Bit Timer/Event Counter	Watch Timer	Watchdog Timer
Type				
Interval timer	1 channel	2 channels	1 channel	1 channel
External event counter	1 channel	2 channels	—	—
Function				
Timer output	1 output	2 outputs	—	—
PWM output	1 output	—	—	—
Pulse width measurement	2 inputs	—	—	—
Square wave output	1 output	2 outputs	—	—
One-shot pulse output	1 output	—	—	—
Interrupt request	2	2	1	1
Test input	—	—	1	—

Figure 5-2. 16-Bit Timer/Event Counter Block Diagram

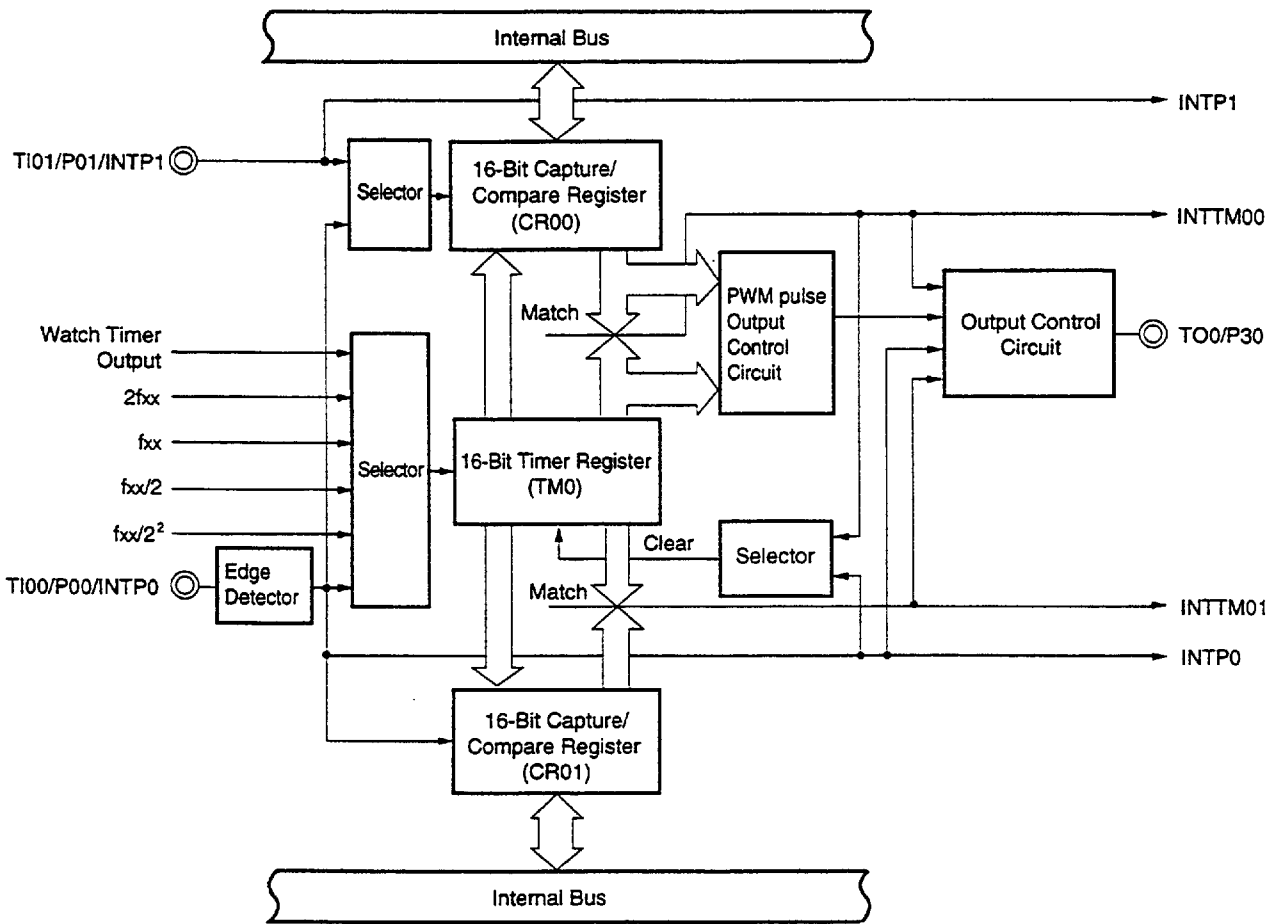

Figure 5-3. 8-Bit Timer/Event Counter Block Diagram

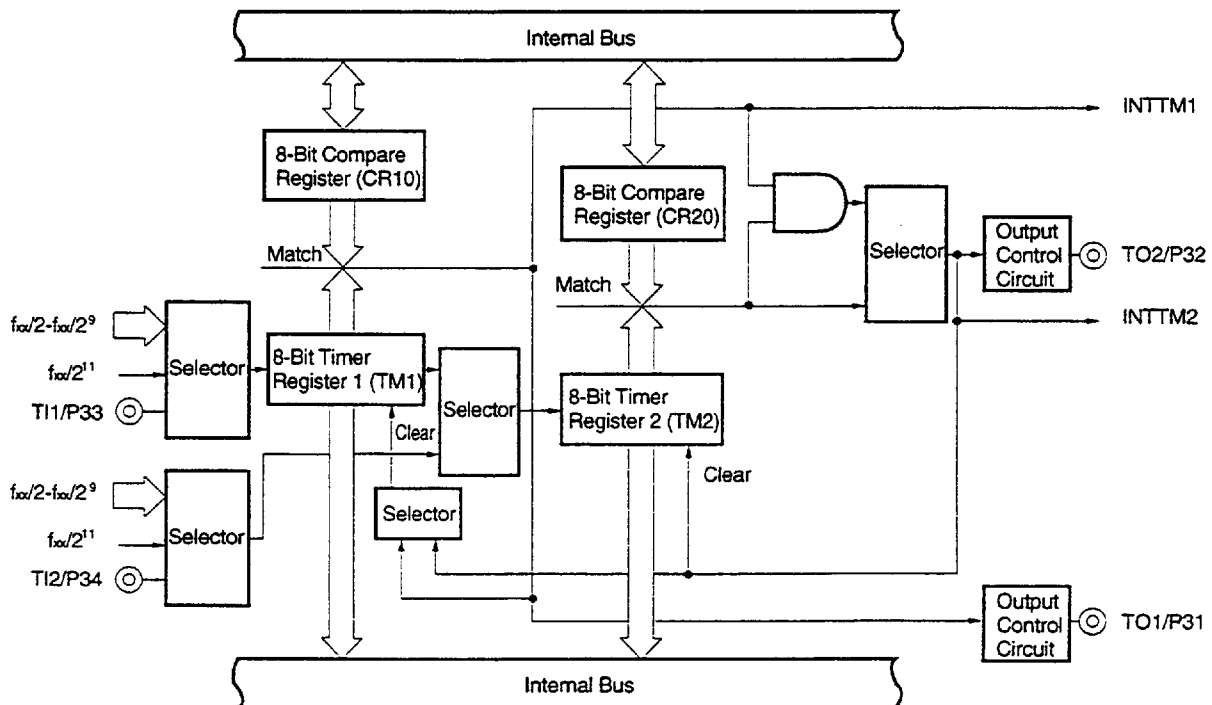

Figure 5-4. Watch Timer Block Diagram

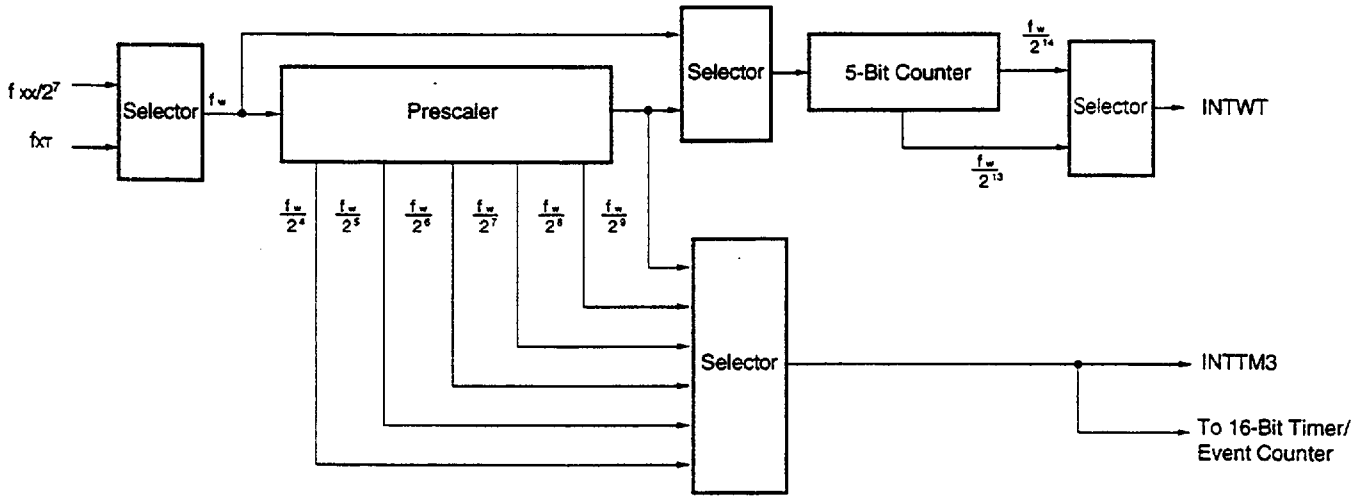
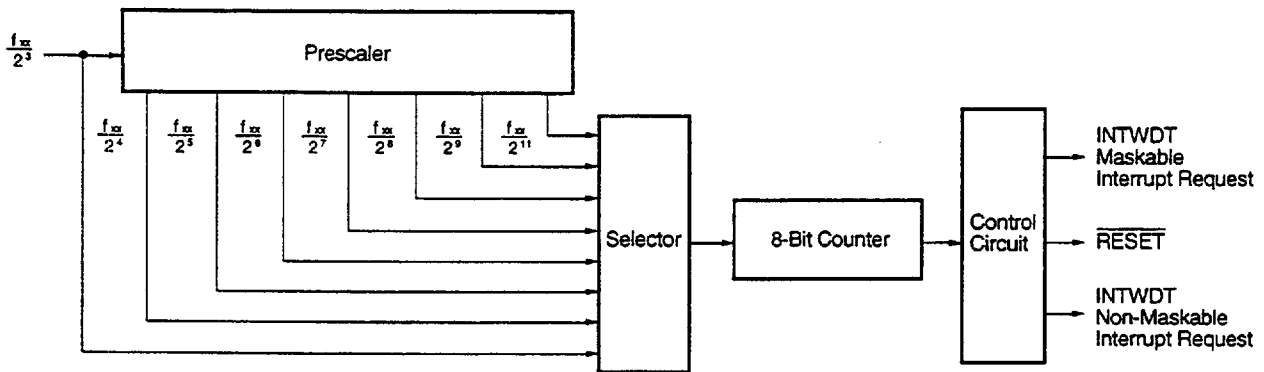

Figure 5-5. Watchdog Timer Block Diagram



5.4 CLOCK OUTPUT CONTROL CIRCUIT

A clock with the following frequencies can be output as the clock output.

- 19.5 kHz/39.1 kHz/78.1 kHz/156 kHz/313 kHz/625 kHz/1.25 MHz/2.5 MHz/5.0 MHz (@5.0-MHz operation with main system clock)
- 32.768 kHz (@32.768-kHz operation with subsystem clock)

Figure 5-6. Clock Output Control Circuit Block Diagram

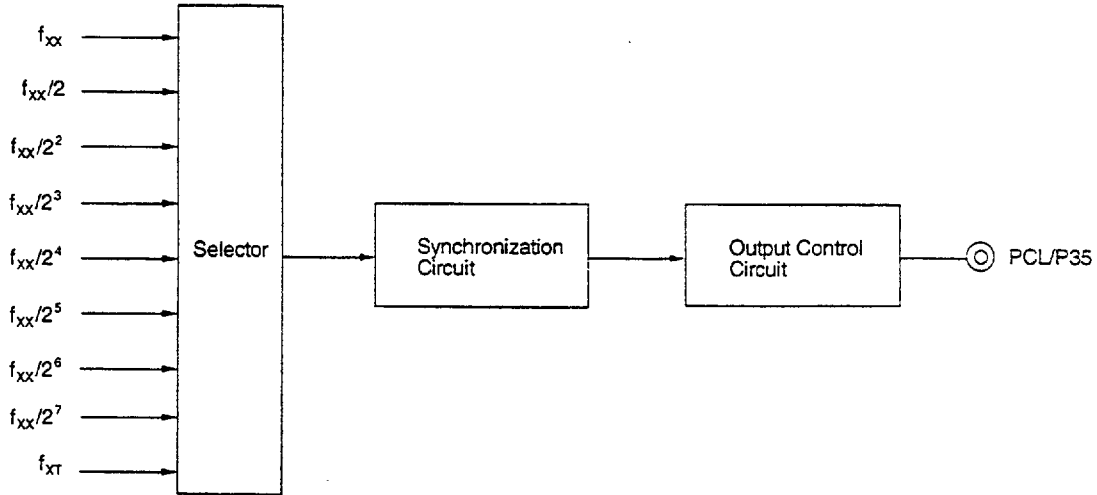

5.5 BUZZER OUTPUT CONTROL CIRCUIT

A clock with the following frequencies can be output as the buzzer output.

- 1.2 kHz/2.4 kHz/4.9 kHz/9.8 kHz (@5.0-MHz operation with main system clock)

Figure 5-7. Buzzer Output Control Circuit Block Diagram

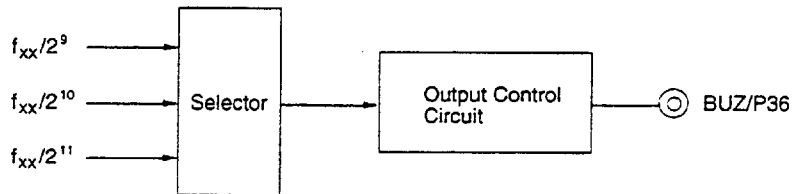

5.6 A/D CONVERTER

An A/D converter of 8-bit resolution x 8 channels is incorporated.

The following two A/D conversion operation start-up methods are available.

- Hardware start
- Software start

Figure 5-8. A/D Converter Block Diagram

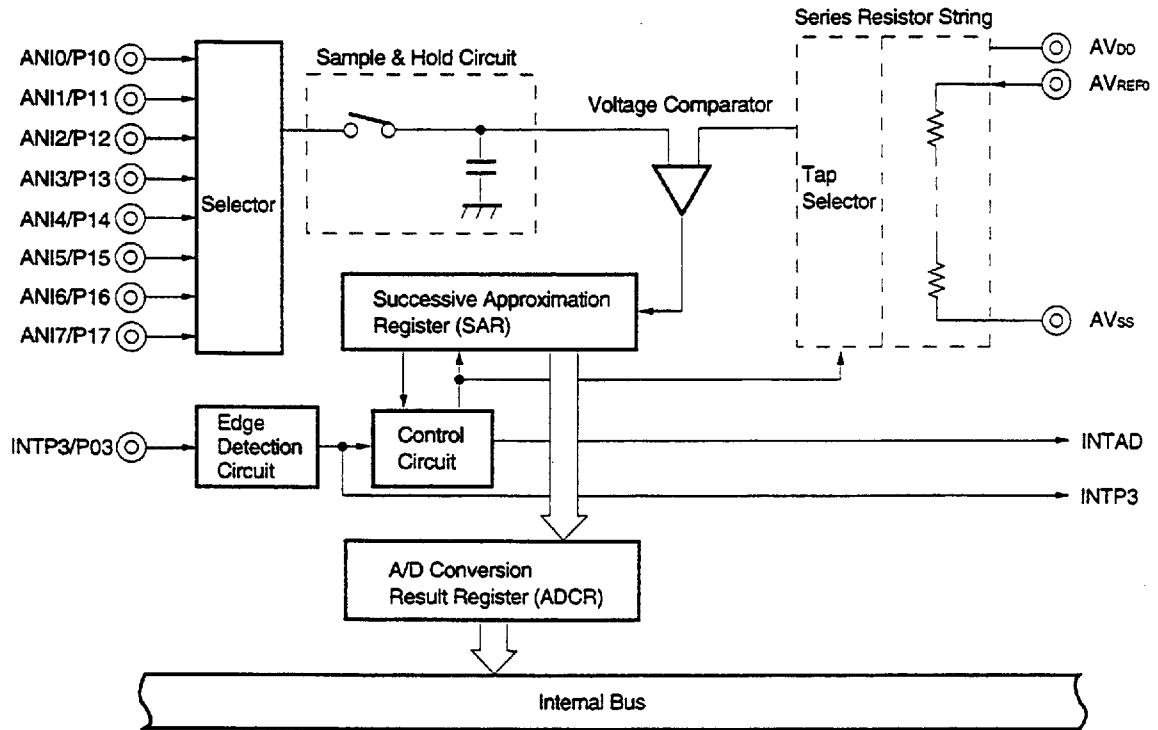

5.7 D/A CONVERTER

A D/A converter of 8-bit resolution x 2 channels is available.
Conversion method is R-2R resistor ladder method.

Figure 5-9. D/A Converter Block Diagram

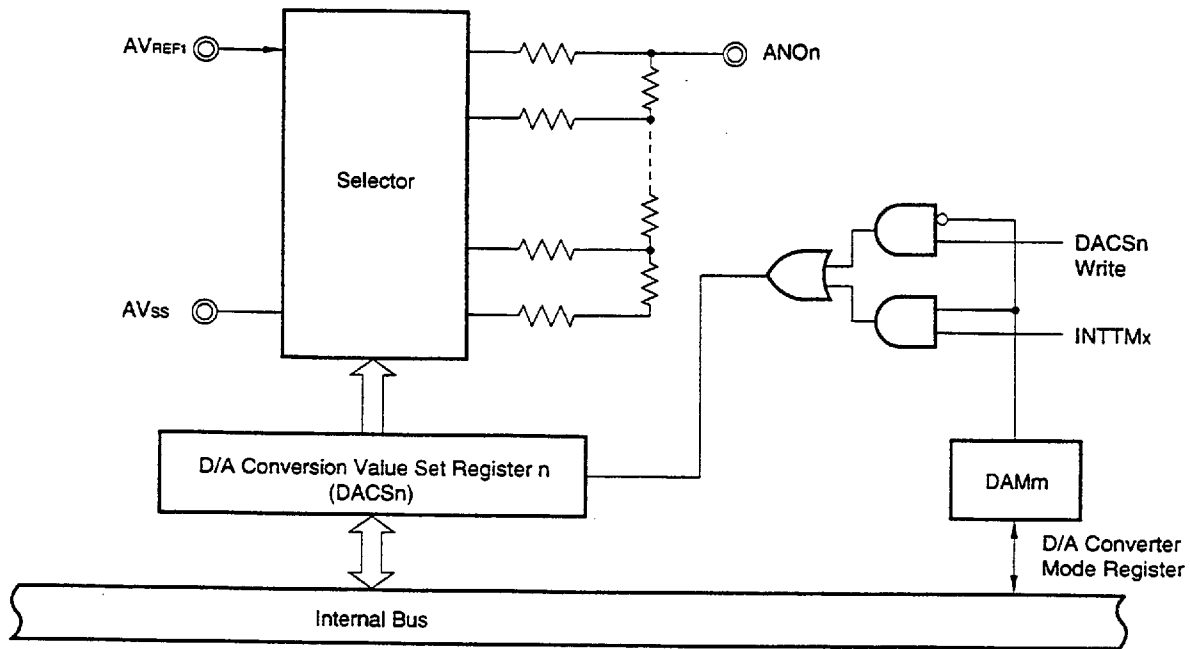

n = 0, 1
m = 4, 5
x = 1, 2

5.8 SERIAL INTERFACES

3 channels of the clocked serial interface are incorporated.

- Serial interface channel 0
- Serial interface channel 1
- Serial interface channel 2

Table 5-3. Types and Functions of Serial Interface

Function	Serial Interface Channel 0	Serial Interface Channel 1	Serial Interface Channel 2
3-wire serial I/O mode	○ (MSB/LSB first switchable)	○ (MSB/LSB first switchable)	○ (MSB/LSB first switchable)
3-wire serial I/O mode with auto-transmit/receive function	—	○ (MSB/LSB first switchable)	—
2-wire serial I/O mode	○ (MSB first)	—	—
I ² C bus mode	○ (MSB first)	—	—
Asynchronous serial interface (UART) mode	—	—	○ (Dedicated baud rate generator incorporated)

Figure 5-10. Serial Interface Channel 0 Block Diagram

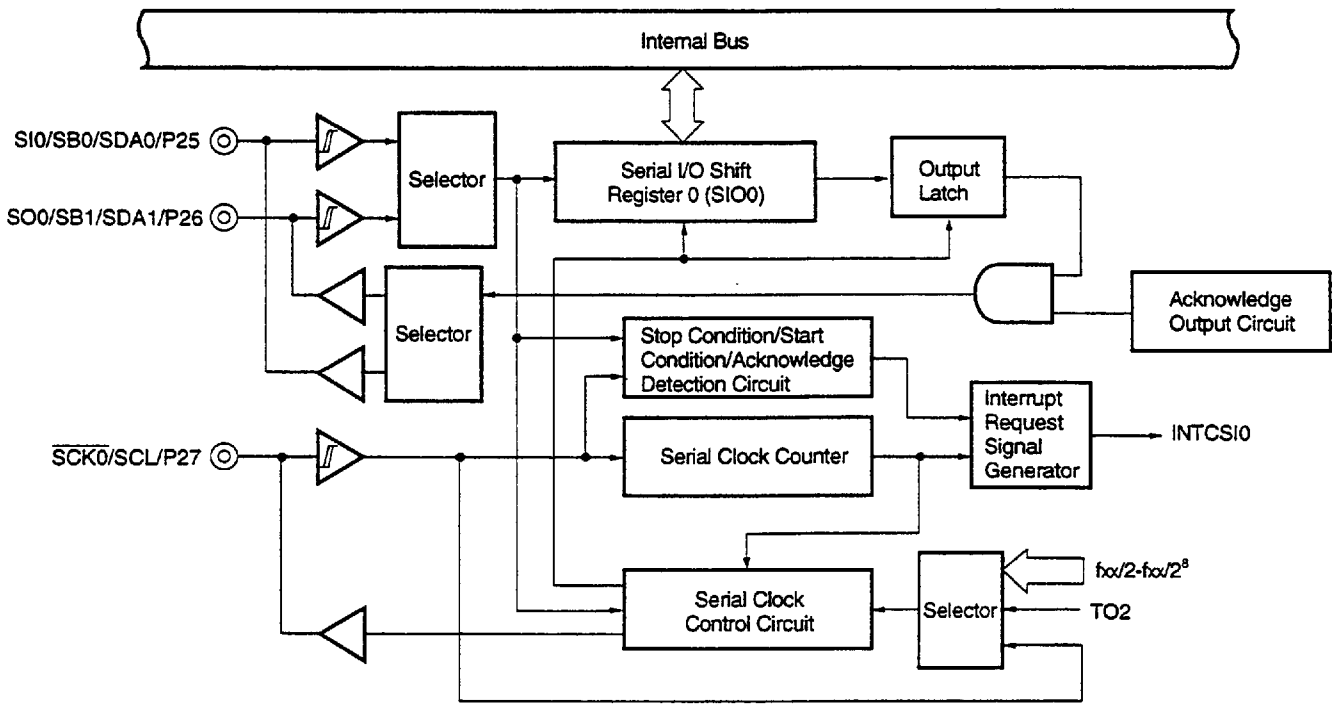

Figure 5-11. Serial Interface Channel 1 Block Diagram

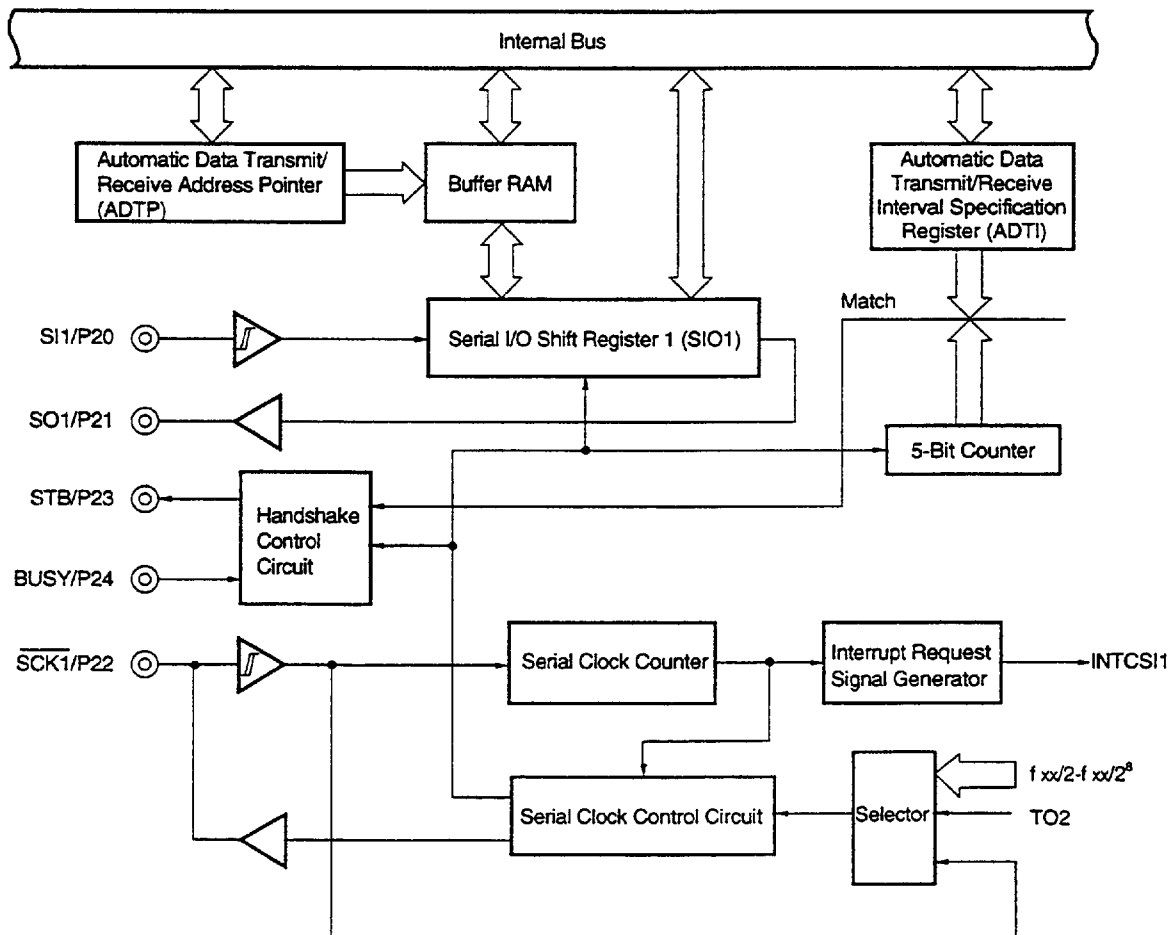
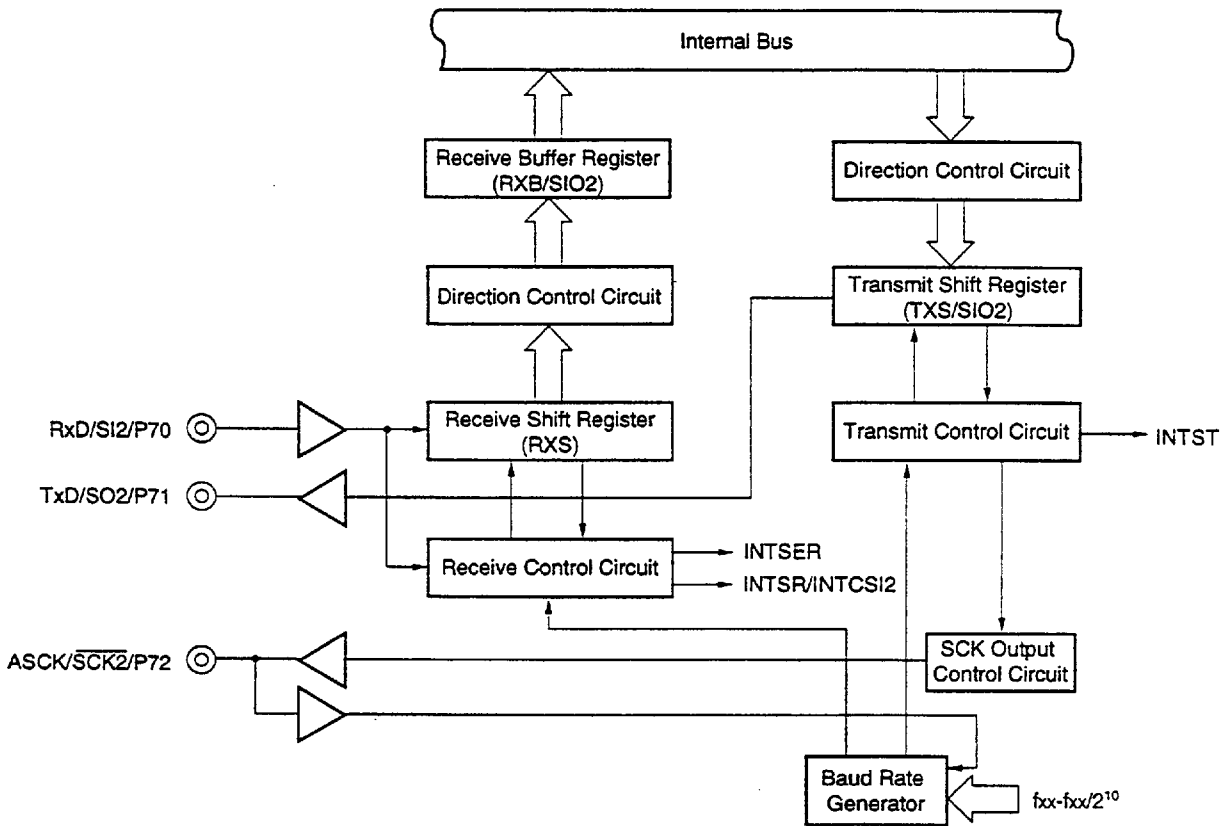

Figure 5-12. Serial Interface Channel 2 Block Diagram



5.9 REAL-TIME OUTPUT PORT FUNCTIONS

Data set previously in the real-time output buffer register is transferred to the output latch by hardware concurrently with timer interrupt or external interrupt generation in order to output to off-chip. This is a real-time output function. Pins used to output data to off-chip are called real-time output ports.

By using a real-time output port, a signal which has no jitter can be output. This is most applicable to control stepping motors, etc.

Figure 5-13. Real-Time Output Port Block Diagram

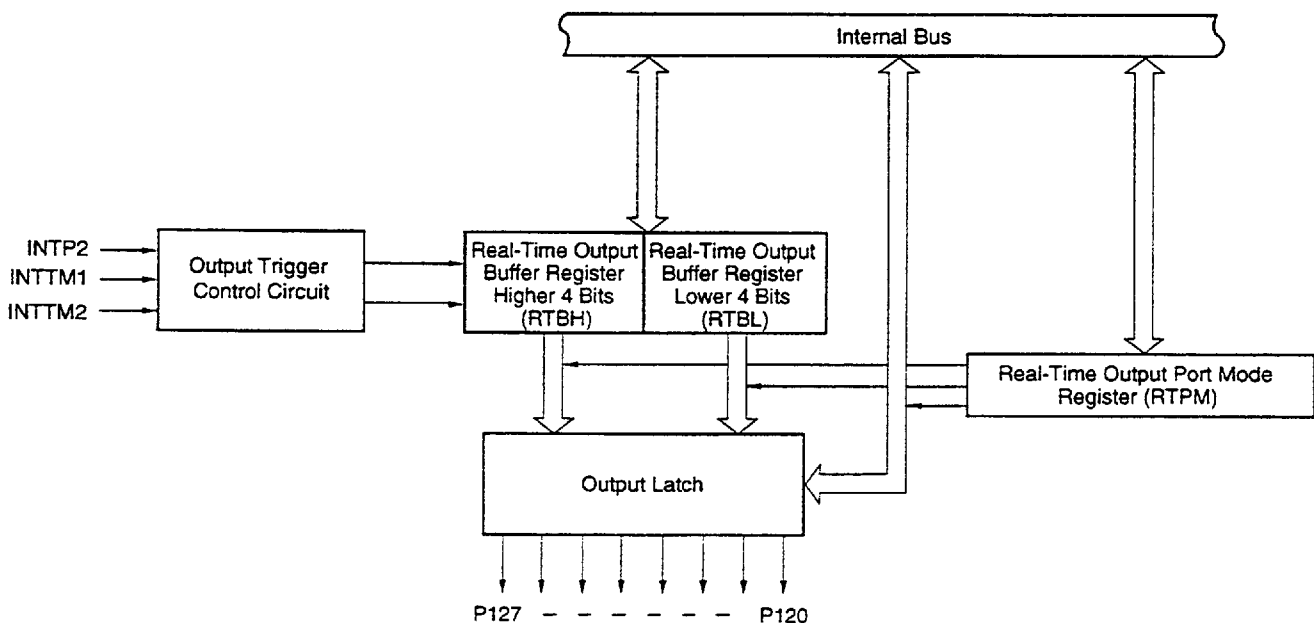

6. INTERRUPT FUNCTIONS AND TEST FUNCTIONS

6.1 INTERRUPT FUNCTIONS

There are 22 interrupt functions of three different types, as shown below.

- Non-maskable interrupt: 1
- Maskable interrupts: 20
- Software interrupt: 1

Table 6-1. Interrupt Source List (1/2)

Interrupt Type	Note 1 Default Priority	Interrupt Source		Internal/ External	Vector Table Address	Basic Configuration Type Note 2		
		Name	Trigger					
Non-maskable	—	INTWDT	Watchdog timer overflow (watchdog timer mode 1 selected)	Internal	0004H	(A)		
Maskable	0	INTWDT	Watchdog timer overflow (interval timer mode selected)			External	0006H	(B)
	1	INTP0	Pin input edge detection	0006H	(C)			
	2	INTP1						
	3	INTP2						
	4	INTP3						
	5	INTP4						
	6	INTP5						
	7	INTP6						
	8	INTCSI0						End of serial interface channel 0 transfer
	9	INTCSI1	End of serial interface channel 1 transfer	0016H				
	10	INTSER	Generation of serial interface channel 2 UART receive error	0018H				
	11	INTSR	End of serial interface channel 2 UART reception	001AH				
INTCSI2		End of serial interface channel 2 3-wire transfer						
12	INTST	End of serial interface channel 2 UART transmission	001CH					

- Notes
1. The default priority is a priority order when two or more maskable interrupts are generated simultaneously. 0 is the highest order and 18, the lowest.
 2. Basic configuration types (A) to (E) correspond to (A) to (E) in Figure 6-1, respectively.

Table 6-1. Interrupt Source List (2/2)

Interrupt Type	Note 1 Default Priority	Interrupt Source		Internal/ External	Vector Table Address	Basic Configuration Type Note 2
		Name	Trigger			
Maskable	13	INTTM3	Reference time interval signal from watch timer	Internal	001EH	(B)
	14	INTTM00	Generation of match signal of 16-bit timer register and capture/compare register (CR00)		0020H	
	15	INTTM01	Generation of match signal of 16-bit timer register and capture/compare register (CR01)		0022H	
	16	INTTM1	Generation of match signal of 8-bit timer/event counter 1		0024H	
	17	INTTM2	Generation of match signal of 8-bit timer/event counter 2		0026H	
	18	INTAD	End of conversion by A/D converter		0028H	
Software	—	BRK	BRK instruction execution	Internal	003EH	(E)

Notes 1. The default priority is a priority order when two or more maskable interrupts are generated simultaneously. 0 is the highest order and 18, the lowest.

2. Basic configuration types (A) to (E) correspond to (A) to (E) in Figure 6-1, respectively.

Figure 6-1. Interrupt Function Basic Configuration(1/2)

(A) Internal non-maskable interrupt

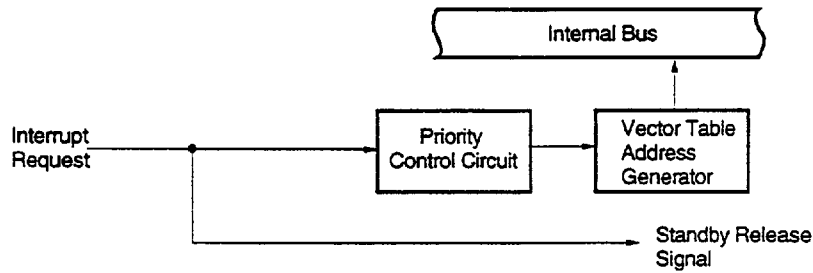

(B) Internal maskable interrupt

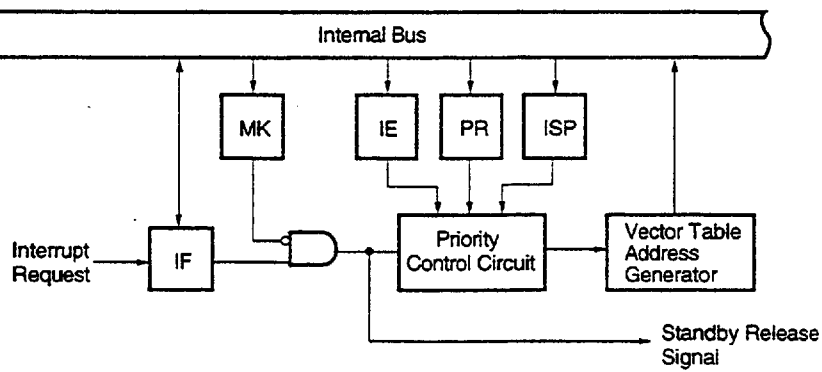

(C) External maskable interrupt (INTP0)

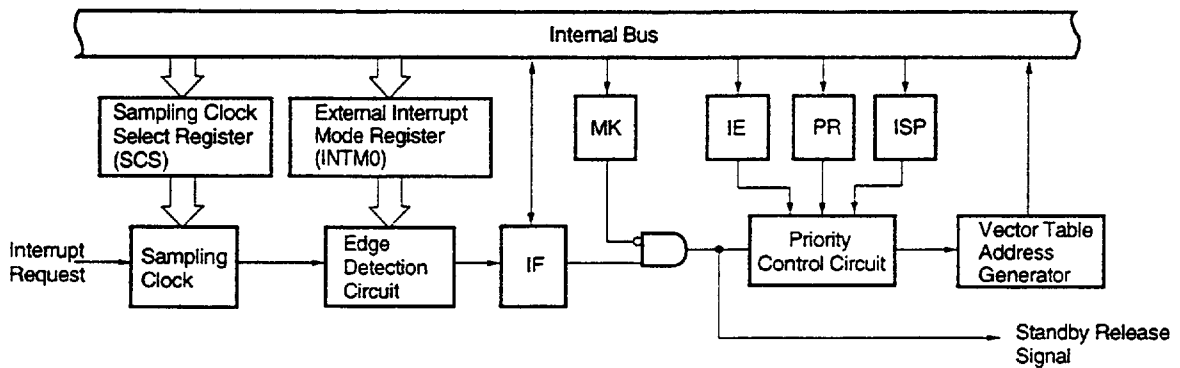
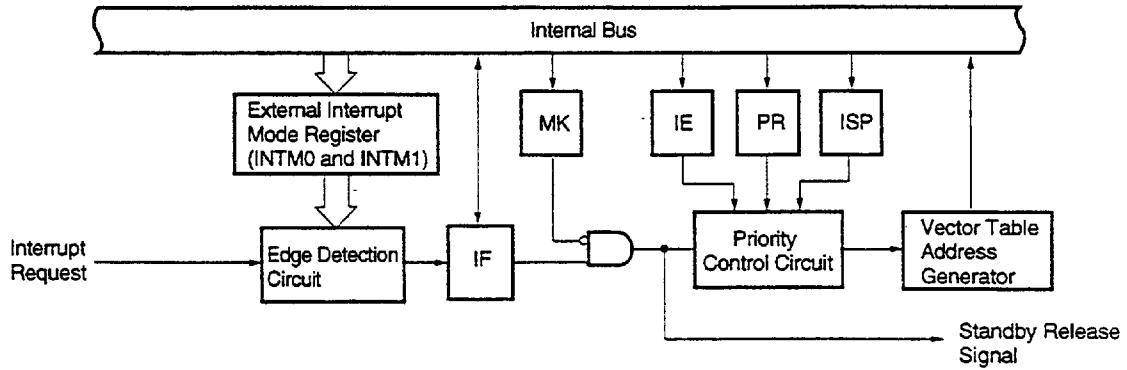
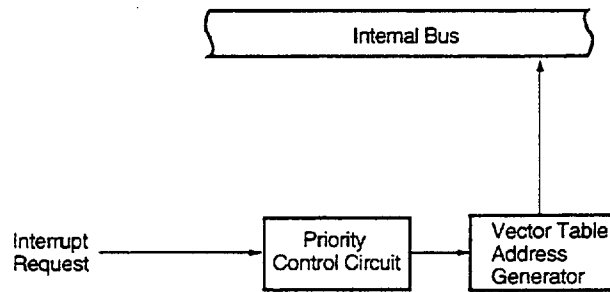

Figure 6-1. Interrupt Function Basic Configuration(2/2)

(D) External maskable interrupt (except INTP0)



(E) Software interrupt



- IF : Interrupt request flag
- IE : Interrupt enable flag
- ISP : In-service priority flag
- MK : Interrupt mask flag
- PR : Priority specification flag

6.2 TEST FUNCTIONS

There are two test functions as shown in Table 6-2.

Table 6-2. Test Input Source List

Test Input Source		Internal/External
Name	Trigger	
INTWT	Watch timer overflow	Internal
INTPT4	Port 4 falling edge detection	External

Figure 6-2. Test Function Basic Configuration

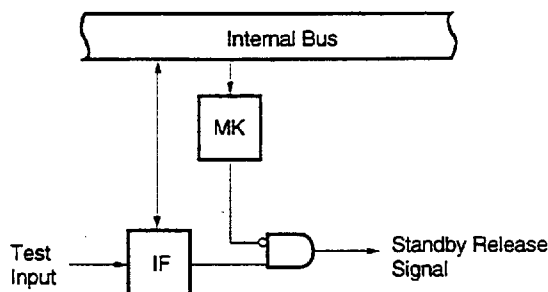

IF : Test input flag
 MK : Test mask flag

7. EXTERNAL DEVICE EXPANSION FUNCTIONS

The external device expansion functions connect external devices to areas other than the internal ROM, RAM, and SFR. Ports 4 to 6 are used for external device connection.

8. STANDBY FUNCTION

There are the following two standby functions to reduce the system current consumption.

- HALT mode : The CPU operating clock is stopped.
The average current consumption can be reduced by intermittent operation in combination with the normal operating mode.
- STOP mode : The main system clock oscillation is stopped. The whole operation by the main system clock is stopped, so that the system operates with ultra-low current consumption using only the subsystem clock.

Figure 8-1. Standby Function

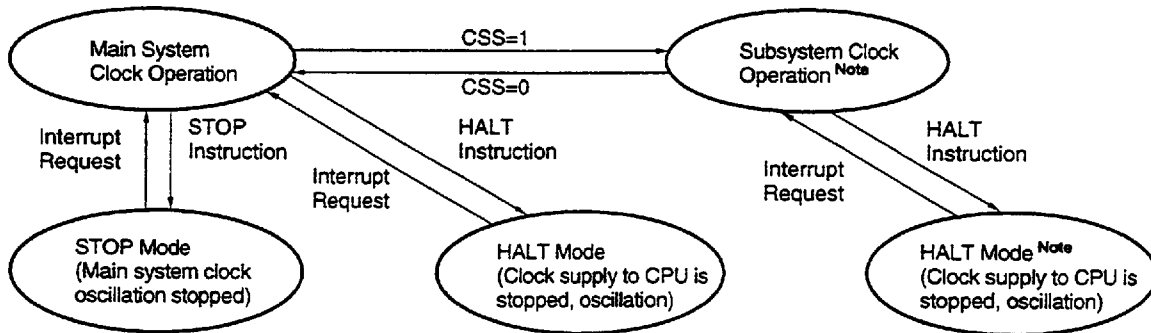

Note The current consumption can be reduced by stopping the main system clock. When the CPU is operating on the subsystem clock, set bit 7 (MCC) of processor clock control register (PCC) to stop the main system clock. The STOP instruction cannot be used.

Caution When the main system clock is stopped and the system is operated by the subsystem clock, the subsystem clock should be switched again to the main system clock after the oscillation stabilization time is secured by the program.

9. RESET FUNCTION

There are the following two reset methods.

- External reset input by $\overline{\text{RESET}}$ pin
- Internal reset by watchdog time runaway time detection

10. INSTRUCTION SET

(1) 8-bit instructions

MOV, XCH, ADD, ADDC, SUB, SUBC, AND, OR, XOR, CMP, MULU, DIVUW, INC, DEC, ROR, ROL, RORC, ROLC, ROR4, ROL4, PUSH, POP, DBNZ

Second Operand First Operand	#byte	A	r Note	sfr	saddr	laddr16	PSW	[DE]	[HL]	[HL + Byte] [HL + B] [HL + C]	\$saddr16	1	None
A	ADD ADDC SUB SUBC AND OR XOR CMP		MOV XCH ADD ADDC SUB SUBC AND OR XOR CMP	MOV XCH	MOV XCH ADD ADDC SUB SUBC AND OR XOR CMP	MOV XCH ADD ADDC SUB SUBC AND OR XOR CMP	MOV	MOV XCH	MOV XCH ADD ADDC SUB SUBC AND OR XOR CMP	MOV XCH ADD ADDC SUB SUBC AND OR XOR CMP		ROR ROL RORC ROLC	
r	MOV	MOV ADD ADDC SUB SUBC AND OR XOR CMP											INC DEC
B, C											DBNZ		
sfr	MOV	MOV											
saddr	MOV ADD ADDC SUB SUBC AND OR XOR CMP	MOV									DBNZ		INC DEC
laddr16		MOV											
PSW	MOV	MOV											PUSH POP
[DE]													
[HL]		MOV											ROR4 ROL4
[HL + Byte] [HL + B] [HL + C]		MOV											
X													MULU
C													DIVUW

Note Except r = A

(2) 16-bit instructions

MOV, XCHW, ADDW, SUBW, CMPW, PUSH, POP, INCW, DECW

Second Operand First Operand	#word	AX	rp ^{Note}	sfrp	saddrp	!addr16	SP	None
AX	ADDW SUBW CMPW		MOVW XCHW	MOVW	MOVW	MOVW	MOVW	
rp	MOVW	MOVW ^{Note}						INCW DECW PUSH POP
sfrp	MOVW	MOVW						
saddrp	MOVW	MOVW						
!addr16		MOVW						
SP	MOVW	MOVW						

Note Only when rp = BC, DE, or HL

(3) Bit manipulate instructions

MOV1, AND1, OR1, XOR1, SET1, CLR1, NOT1, BT, BF, BTCLR

Second Operand First Operand	A.bit	sfr.bit	saddr.bit	PSW.bit	[HL].bit	CY	Saddr16	None
A.bit						MOV1	BT BF BTCLR	SET1 CLR1
sfr.bit						MOV1	BT BF BTCLR	SET1 CLR1
saddr.bit						MOV1	BT BF BTCLR	SET1 CLR1
PSW.bit						MOV1	BT BF BTCLR	SET1 CLR1
[HL].bit						MOV1	BT BF BTCLR	SET1 CLR1
CY	MOV1 AND1 OR1 XOR1	MOV1 AND1 OR1 XOR1	MOV1 AND1 OR1 XOR1	MOV1 AND1 OR1 XOR1	MOV1 AND1 OR1 XOR1			SET1 CLR1 NOT1

(4) Call instruction/branch instructions

CALL, CALLF, CALLT, BR, BC, BNC, BZ, BNZ, BT, BF, BTCLR, DBNZ

Second Operand First Operand	AX	!addr16	!addr11	[addr5]	\$addr16
Basic instruction	BR	CALL BR	CALLF	CALLT	BR BC BNC BZ BNZ
Compound instruction					BT BF BTCLR DBNZ

(5) Other instructions

ADJBA, ADJBS, BRK, RET, RETI, RETB, SEL, NOP, EI, DI, HALT, STOP

11. ELECTRICAL SPECIFICATIONS

★

ABSOLUTE MAXIMUM RATINGS (T_A = 25 °C)

Parameter	Symbol	Test Conditions		Ratings	Unit		
Supply voltage	V _{DD}			-0.3 to +7.0	V		
	AV _{DD}			-0.3 to V _{DD} + 0.3	V		
	AV _{REF0}			-0.3 to V _{DD} + 0.3	V		
	AV _{REF1}			-0.3 to V _{DD} + 0.3	V		
	AV _{SS}			-0.3 to +0.3	V		
Input voltage	V _{I1}	P00 to P07, P10 to P17, P20 to P27, P30 to P37, P40 to P47, P50 to P57, P64 to P67, P70 to P72, P120 to P127, P130, P131, X1, X2, XT2, $\overline{\text{RESET}}$		-0.3 to V _{DD} + 0.3	V		
	V _{I2}	P60 to P63	N-ch Open-drain	-0.3 to +16	V		
Output voltage	V _O			-0.3 to V _{DD} + 0.3	V		
Analog input voltage	V _{AN}	P10 to P17	Analog input pin	AV _{SS} - 0.3 to AV _{REF0} + 0.3	V		
Output current high	I _{OH}	1 pin		-10	mA		
		P01 to P06, P30-P37, P56, P57, P60 to P67, P120 to P127 total		-15	mA		
		P10 to P17, P20 to P27, P40 to P47, P50 to P55, P70 to P72, P130, P131 total		-15	mA		
Output current low	I _{OL} <small>Note</small>	1 pin	Peak value	30	mA		
			r.m.s.	15	mA		
		P50 to P55 total	Peak value	100	mA		
			r.m.s.	70	mA		
		P56, P57, P60 to P63 total	Peak value	100	mA		
			r.m.s.	70	mA		
		P10 to P17, P20 to P27, P40 to P47, P70 to P72, P130, P131 total	Peak value	50	mA		
			r.m.s.	20	mA		
		P01 to P06, P30 to P37, P64 to P67, P120 to P127 total	Peak value	50	mA		
			r.m.s.	20	mA		
		Operating ambient temperature	T _A			-40 to +85	°C
		Storage temperature	T _{stg}			-65 to +150	°C

Note The r.m.s. should be calculated as follows: [r.m.s.] = [Peak value] x $\sqrt{\text{duty}}$

Caution If any of the parameters exceed the absolute maximum ratings, even momentarily, device reliability may be impaired. The absolute maximum ratings are values that may physically damage the product. Be sure to use the product within the ratings.

Remark The characteristics of dual-function pins and port pins are the same unless otherwise specified.

MAIN SYSTEM CLOCK OSCILLATION CIRCUIT CHARACTERISTICS (T_A = -40 to +85 °C, V_{DD} = 2.0 to 6.0 V)

Resonator	Recommended Circuit	Parameter	Test Conditions	MIN.	TYP.	MAX.	Unit
Ceramic resonator		Oscillation frequency (f _x) <i>Note1</i>	V _{DD} = Oscillation voltage range	1.0		5.0	MHz
		Oscillation stabilization time <i>Note2</i>	After V _{DD} reaches oscillation voltage range MIN.			4	ms
Crystal resonator		Oscillation frequency (f _x) <i>Note1</i>		1.0		5.0	MHz
		Oscillation stabilization time <i>Note2</i>	V _{DD} = 4.5 to 6.0 V			10 30	ms
External clock		X1 input frequency (f _x) <i>Note1</i>		1.0		5.0	MHz
		X1 input high/low level width (t _H , t _L)			85		500

- Notes**
1. Indicates only oscillation circuit characteristics. Refer to "AC Characteristics" for instruction execution time.
 2. Time required to stabilize oscillation after reset or STOP mode release.

Cautions 1. When using the main system clock oscillator, wiring in the area enclosed with the broken line should be carried out as follows to avoid adverse effects from wiring capacitance.

- Wiring should be as short as possible.
- Wiring should not cross other signal lines.
- Wiring should not be placed close to a varying high current.
- The potential of the oscillator capacitor ground should be the same as V_{SS}.
- Do not ground wiring to a ground pattern in which a high current flows.
- Do not fetch a signal from the oscillator.

2. When the main system clock is stopped and the system is operated by the subsystem clock, the subsystem clock should be switched again to the main system clock after the oscillation stabilization time is secured by the program.

SUBSYSTEM CLOCK OSCILLATION CIRCUIT CHARACTERISTICS (T_A = -40 to +85 °C, V_{DD} = 2.0 to 6.0 V)

Resonator	Recommended Circuit	Parameter	Test Conditions	MIN.	TYP.	MAX.	Unit
Crystal resonator		Oscillation frequency (f _{XT}) Note 1		32	32.768	35	kHz
		Oscillation stabilization time Note 2	V _{DD} = 4.5 to 6.0 V		1.2	2	s
External clock		XT1 input frequency (f _{XT}) Note 1		32		100	kHz
		XT1 input high/low level width (t _{PH} , t _{PL})		5		15	μs

- Notes**
1. Indicates only oscillation circuit characteristics. Refer to "AC Characteristics" for instruction execution time.
 2. Time required to stabilize oscillation after applying power (V_{DD}).

Cautions

1. When using the subsystem clock oscillator, wiring in the area enclosed with the broken line should be carried out as follows to avoid an adverse effect from wiring capacitance.

- Wiring should be as short as possible.
- Wiring should not cross other signal lines.
- Wiring should not be placed close to a varying high current.
- The potential of the oscillator capacitor ground should be the same as V_{SS}.
- Do not ground wiring to a ground pattern in which a high current flows.
- Do not fetch a signal from the oscillator.

2. The subsystem clock oscillation circuit is a circuit with a low amplification level, more prone to misoperation due to noise than the main system clock. When using the subsystem clock, pay special attention to wiring as described above.

RECOMMENDED OSCILLATOR CONSTANT

(1) μPD78052Y, 78053Y, 78054Y, 78055Y, 78056Y

MAIN SYSTEM CLOCK: CERAMIC RESONATOR (T_A = -40 to +85 °C)

Manufacturer	Product Name	Frequency (MHz)	Recommended Oscillator Constant			Oscillation Voltage Range		Remarks
			C1 (pF)	C2 (pF)	R1 (kΩ)	MIN. (V)	MAX. (V)	
Murata Mfg. Co., Ltd.	CSA5.00MG	5.00	30	30	0	2.0	6.0	
	CST5.00MGW	5.00	On-chip	On-chip	0	2.0	6.0	Capacitor on chip
Kyocera	KBR-5.0MSA	5.00	33	33	0	2.0	6.0	Lead type
	KBR-5.0MKS	5.00	On-chip	On-chip	0	2.0	6.0	Capacitor on chip, lead type
	KBR-5.0MWS	5.00	On-chip	On-chip	0	2.0	6.0	Capacitor on chip, lead type
	PBRC 5.00A	5.00	33	33	0	2.0	6.0	Chip type
TDK Corp.	CCR4.0MC3	4.00	On-chip	On-chip	0	2.0	6.0	Capacitor on chip
	CCR5.0MC3	5.00	On-chip	On-chip	0	2.0	6.0	Capacitor on chip

MAIN SYSTEM CLOCK: CRYSTAL RESONATOR (T_A = -10 to +70 °C)

Manufacturer	Product Name	Frequency (MHz)	Recommended Oscillator Constant			Oscillation Voltage Range	
			C1 (pF)	C2 (pF)	R1 (kΩ)	MIN. (V)	MAX. (V)
Daishinku	SMD-49	3.579545	27	27	1.5	2.0	6.0

SUBSYSTEM CLOCK: CRYSTAL RESONATOR (T_A = -10 to +70 °C)

Manufacturer	Product Name	Frequency (MHz)	Recommended Oscillator Constant			Oscillation Voltage Range	
			C1 (pF)	C2 (pF)	R1 (kΩ)	MIN. (V)	MAX. (V)
Daishinku	DT-38 (1TA252E00)	32.768	27	20	330	2.0	6.0

Caution The oscillator constant and oscillation voltage range indicated above are conditions for stable oscillation and do not guarantee oscillating frequency accuracy. If frequency accuracy is necessary for the user's circuit, the frequency of the resonator in the circuit must be adjusted. Therefore, it is recommended that the user directly consult the resonator manufacturer before designing.

(2) μPD78058Y

MAIN SYSTEM CLOCK: CERAMIC RESONATOR (T_A = -40 to +85 °C)

Manufacturer	Product Name	Frequency (MHz)	Recommended Oscillator Constant			Oscillation Voltage Range		Remarks
			C1 (pF)	C2 (pF)	R1 (kΩ)	MIN. (V)	MAX. (V)	
Kyocera	PBRC4.19A	4.19	33	33	0	2.0	6.0	
	PBRC4.19B	4.19	On-chip	On-chip	0	2.0	6.0	Capacitor on chip
	KBR-4.19MSA	4.19	33	33	0	2.0	6.0	
	KBR-4.19MKS	4.19	On-chip	On-chip	0	2.0	6.0	Capacitor on chip
	PBRC4.91A	4.91	33	33	0	2.0	6.0	
	PBRC4.91B	4.91	On-chip	On-chip	0	2.0	6.0	Capacitor on chip
	KBR-4.91MSA	4.91	33	33	0	2.0	6.0	
	KBR-4.91MKS	4.91	On-chip	On-chip	0	2.0	6.0	Capacitor on chip

Caution The oscillator constant and oscillation voltage range indicated above are conditions for stable oscillation and do not guarantee oscillating frequency accuracy. If frequency accuracy is necessary for the user's circuit, the frequency of the resonator in the circuit must be adjusted. Therefore, it is recommended that the user directly consult the resonator manufacturer before designing.

CAPACITANCE (T_A = 25 °C, V_{DD} = V_{SS} = 0 V)

Parameter	Symbol	Test Conditions		MIN.	TYP.	MAX.	Unit
Input capacitance	C _{IN}	f = 1 MHz Unmeasured pins returned to 0 V.				15	pF
Input/Output capacitance	C _{IO}	f = 1 MHz Unmeasured pins returned to 0 V.	P01 to P06, P10 to P17, P20 to P27, P30 to P37, P40 to P47, P50 to P57, P64 to P67, P70 to P72, P120 to P127, P130, P131			15	pF
			P60 to P63			20	pF

Remark The characteristics of the dual-function pins and port pins are the same unless otherwise specified.

DC CHARACTERISTICS (T_A = -40 to +85 °C, V_{DD} = 2.0 to 6.0 V)

Parameter	Symbol	Test Conditions	MIN.	TYP.	MAX.	Unit	
Input voltage high	V _{IH1}	P10 to P17, P21, P23, P30 to P32, P35 to P37, P40 to P47, P50 to P57, P64 to P67, P71, P120 to P127, P130, P131	V _{DD} = 2.7 to 6.0 V	0.7V _{DD}		V _{DD}	V
				0.8V _{DD}		V _{DD}	V
	V _{IH2}	P00 to P06, P20, P22, P24 to P27, P33, P34, P70, P72, $\overline{\text{RESET}}$	V _{DD} = 2.7 to 6.0 V	0.8V _{DD}		V _{DD}	V
				0.85V _{DD}		V _{DD}	V
	V _{IH3}	P60 to P63 (N-ch Open-drain)	V _{DD} = 2.7 to 6.0 V	0.7V _{DD}		15	V
				0.8V _{DD}		15	V
	V _{IH4}	X1, X2	V _{DD} = 2.7 to 6.0 V	V _{DD} -0.5		V _{DD}	V
				V _{DD} -0.2		V _{DD}	V
	V _{IH5}	XT1/P07, XT2	4.5 V ≤ V _{DD} ≤ 6.0 V	0.8V _{DD}		V _{DD}	V
			2.7 V ≤ V _{DD} < 4.5 V	0.9V _{DD}		V _{DD}	V
2.0 V ≤ V _{DD} < 2.7 V ^{Note}			0.9V _{DD}		V _{DD}	V	
Input voltage low	V _{IL1}	P10 to P17, P21, P23, P30 to P32, P35 to P37, P40 to P47, P50 to P57, P64 to P67, P71, P120 to P127, P130, P131	V _{DD} = 2.7 to 6.0 V	0		0.3V _{DD}	V
				0		0.2V _{DD}	V
	V _{IL2}	P00 to P06, P20, P22, P24 to P27, P33, P34, P70, P72, $\overline{\text{RESET}}$	V _{DD} = 2.7 to 6.0 V	0		0.2V _{DD}	V
				0		0.15V _{DD}	V
	V _{IL3}	P60 to P63	4.5 V ≤ V _{DD} ≤ 6.0 V	0		0.3V _{DD}	V
			2.7 V ≤ V _{DD} < 4.5 V	0		0.2V _{DD}	V
				0		0.1V _{DD}	V
	V _{IL4}	X1, X2	V _{DD} = 2.7 to 6.0 V	0		0.4	V
				0		0.2	V
	V _{IL5}	XT1/P07, XT2	4.5 V ≤ V _{DD} ≤ 6.0 V	0		0.2V _{DD}	V
2.7 V ≤ V _{DD} < 4.5 V			0		0.1V _{DD}	V	
2.0 V ≤ V _{DD} < 2.7 V ^{Note}			0		0.1V _{DD}	V	
Output voltage high	V _{OH}	V _{DD} = 4.5 to 6.0 V, I _{OH} = -1 mA	V _{DD} -1.0			V	
		I _{OH} = -100 μA	V _{DD} -0.5			V	
Output voltage low	V _{OL1}	P50 to P57, P60 to P63	V _{DD} = 4.5 to 6.0 V, I _{OL} = 15 mA		0.4	2.0	V
		P01 to P06, P10 to P17, P20 to P27, P30 to P37, P40 to P47, P64 to P67, P70 to P72, P120 to P127, P130, P131	V _{DD} = 4.5 to 6.0 V, I _{OL} = 1.6 mA			0.4	V
	V _{OL2}	SB0, SB1, $\overline{\text{SCK0}}$	V _{DD} = 4.5 to 6.0 V, open-drain pulled-up (R = 1 KΩ)			0.2V _{DD}	V
	V _{OL3}	I _{OL} = 400 μA				0.5	V

Note For use as P07, use an inverter to input the reverse phase of P07 to the XT2 pin.

Remark The characteristics of dual-function pins and port pins are the same unless otherwise specified.

DC CHARACTERISTICS (T_A = -40 to +85 °C, V_{DD} = 2.7 to 6.0 V)

Parameter	Symbol	Test Conditions		MIN.	TYP.	MAX.	Unit
Input leakage current high	I _{LH1}	V _{IN} = V _{DD}	P00 to P06, P10 to P17, P20 to P27, P30 to P37, P40 to P47, P50 to P57, P60 to P67, P70 to P72, P120 to P127, P130, P131, $\overline{\text{RESET}}$			3	μA
	I _{LH2}		X1, X2, XT1/P07, XT2			20	μA
	I _{LH3}	V _{IN} = 15 V	P60 to P63			80	μA
Input leakage current low	I _{LIL1}	V _{IN} = 0 V	P00 to P06, P10 to P17, P20 to P27, P30 to P37, P40 to P47, P50 to P57, P64 to P67, P70 to P72, P120 to P127, P130, P131, $\overline{\text{RESET}}$			-3	μA
	I _{LIL2}		X1, X2, XT1/P07, XT2			-20	μA
	I _{LIL3}		P60 to P63			-3 ^{Note1}	μA
Output leakage current high	I _{LOH}	V _{OUT} = V _{DD}				3	μA
Output leakage current low	I _{LOL}	V _{OUT} = 0 V				-3	μA
Mask option pull-up resistor	R ₁	V _{IN} = 0 V, P60 to P63		20	40	90	kΩ
Software pull-up resistor ^{Note2}	R ₂	V _{IN} = 0 V, P01 to P06, P10 to P17, P20 to P27, P30 to P37, P40 to P47, P50 to P57, P64 to P67, P70 to P72, P120 to P127, P130, P131	4.5 V ≤ V _{DD} ≤ 6.0 V	15	40	90	kΩ
			2.7 V ≤ V _{DD} < 4.5 V	20		500	kΩ

- Notes**
1. If no pull-up resistor is connected in P60 to P63 (specified with mask option), a -200 μA (MAX.) low-level input leak current flows only during the 1.5-clock interval (no wait interval) during which a read instruction is executed for port 6 (P6) and port mode register (PM6).
The leak current is -3 μA (MAX.) at all times other than the 1.5-clock interval during which the read instruction is executed.
 2. A software pull-up resistor can be used only in the range of V_{DD} = 2.7 to 6.0 V.

Remark The characteristics of dual-function pins and port pins are the same unless otherwise specified.

DC CHARACTERISTICS (T_A = -40 to +85 °C, V_{DD} = 2.0 to 6.0 V)

Parameter	Symbol	Test Conditions	MIN.	TYP.	MAX.	Unit	
Power supply current Note1	I _{DD1}	5.0-MHz Crystal oscillation operating mode (f _{xx} = 2.5 MHz) Note2	V _{DD} = 5.0 V ± 10 % Note5		4	12	mA
			V _{DD} = 3.0 V ± 10 % Note6		0.6	1.8	mA
			V _{DD} = 2.2 V ± 10 % Note6		0.35	1.05	mA
		5.0-MHz Crystal oscillation operating mode (f _{xx} = 5.0 MHz) Note3	V _{DD} = 5.0 V ± 10 % Note5		6.5	19.5	mA
			V _{DD} = 3.0 V ± 10 % Note6		0.8	2.4	mA
			V _{DD} = 2.2 V ± 10 %				
	I _{DD2}	5.0-MHz Crystal oscillation HALT mode (f _{xx} = 2.5 MHz) Note2	V _{DD} = 5.0 V ± 10 %		1.4	4.2	mA
			V _{DD} = 3.0 V ± 10 %		0.5	1.5	mA
			V _{DD} = 2.2 V ± 10 %		280	840	μA
		5.0-MHz Crystal oscillation HALT mode (f _{xx} = 5.0 MHz) Note3	V _{DD} = 5.0 V ± 10 %		1.6	4.8	mA
	V _{DD} = 3.0 V ± 10 %			0.65	1.95	mA	
	I _{DD3}	32.768-kHz Crystal oscillation operating mode Note4	V _{DD} = 5.0 V ± 10 %		60	120	μA
			V _{DD} = 3.0 V ± 10 %		32	64	μA
			V _{DD} = 2.2 V ± 10 %		24	48	μA
	I _{DD4}	32.768-kHz Crystal oscillation HALT mode Note4	V _{DD} = 5.0 V ± 10 %		25	55	μA
			V _{DD} = 3.0 V ± 10 %		5	15	μA
			V _{DD} = 2.2 V ± 10 %		2.5	12.5	μA
	I _{DD5}	XT1 = V _{DD} STOP mode When feedback resistor is used	V _{DD} = 5.0 V ± 10 %		1	30	μA
V _{DD} = 3.0 V ± 10 %				0.5	10	μA	
V _{DD} = 2.2 V ± 10 %				0.3	10	μA	
I _{DD6}	XT1 = V _{DD} STOP mode When feedback resistor is unused	V _{DD} = 5.0 V ± 10 %		0.1	30	μA	
		V _{DD} = 3.0 V ± 10 %		0.05	10	μA	
		V _{DD} = 2.2 V ± 10 %		0.05	10	μA	

- Notes**
1. The AV_{REF0}, AV_{REF1}, AV_{DD} current, and port current (including the current flowing in the on-chip pull-up resistor) are not included.
 2. Operation with f_{xx} = f_x/2 (when oscillation mode selection register (OSMS) is set to 00H)
 3. Operation with f_{xx} = f_x (when OSMS is set to 01H)
 4. When the main system clock is halted.
 5. Operating in high-speed mode (when the processor clock control register (PCC) is set to 00H.)
 6. Operating in low-speed mode (when PCC is set to 04H)

f_{xx} : Main system clock frequency (f_x or f_x/2)

f_x : Main system clock oscillation frequency

AC CHARACTERISTICS

(1) BASIC OPERATION (TA = -40 to +85 °C, VDD = 2.0 to 6.0 V)

Parameter	Symbol	Test Conditions		MIN.	TYP.	MAX.	Unit	
Cycle time (Min. instruction execution time)	T _{cy}	Operating on main system clock	f _{xx} = f _x /2 Note1	V _{DD} = 2.7 to 6.0 V	0.8		64	μs
					2.2		64	μs
			f _{xx} = f _x Note2	4.5 V ≤ V _{DD} ≤ 6.0 V	0.4		32	μs
				2.7 V ≤ V _{DD} < 4.5 V	0.8		32	μs
		Operating on sub system clock		40	122	125	μs	
T100 input high-/low-level width	t _{TH00} , t _{TL00}	3.5 V ≤ V _{DD} ≤ 6.0 V		2/f _{sam} +0.1 Note3			μs	
		2.7 V ≤ V _{DD} < 3.5 V		2/f _{sam} +0.2 Note3			μs	
				2/f _{sam} +0.5 Note3			μs	
T101 input high-/low-level width	t _{TH01} , t _{TL01}	V _{DD} = 2.7 to 6.0 V		10			μs	
				20			μs	
T11, T12 input frequency	f _{T11}	V _{DD} = 4.5 to 6.0 V		0		4	MHz	
				0		275	kHz	
T11, T12 input high-/low-level width	t _{TH11} , t _{TL11}	V _{DD} = 4.5 to 6.0 V		100			ns	
				1.8			μs	
Interrupt input high-/low-level width	t _{INTH} , t _{INTL}	INTP0	3.5 V ≤ V _{DD} ≤ 6.0 V	2/f _{sam} +0.1 Note3			μs	
			2.7 V ≤ V _{DD} < 3.5 V	2/f _{sam} +0.2 Note3			μs	
				2/f _{sam} +0.5 Note3			μs	
		INTP1 to INTP6, KR0 to KR7	V _{DD} = 2.7 to 6.0 V		10			μs
					20			μs
RESET low level width	t _{RSL}	V _{DD} = 2.7 to 6.0 V		10			μs	
				20			μs	

- Notes**
1. When oscillation mode selection register (OSMS) is set to 00H
 2. When OSMS is set to 01H
 3. In combination with bits 0 (SCS0) and 1 (SCS1) of sampling clock selection register, f_{sam} is selectable between f_{xx}/2^N, f_{xx}/32, f_{xx}/64, and f_{xx}/128 (when N= 0 to 4).

f_{xx} : Main system clock frequency (f_x or f_x/2)

f_x : Main system clock oscillation frequency

T_{cy} vs V_{DD} (At $f_{xx} = f_x/2$ main system clock operation)

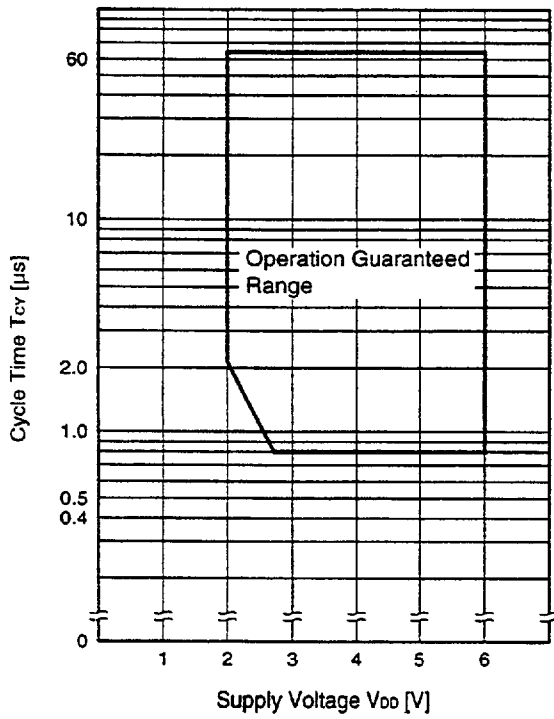

T_{cy} vs V_{DD} (At $f_{xx} = f_x$ main system clock operation)

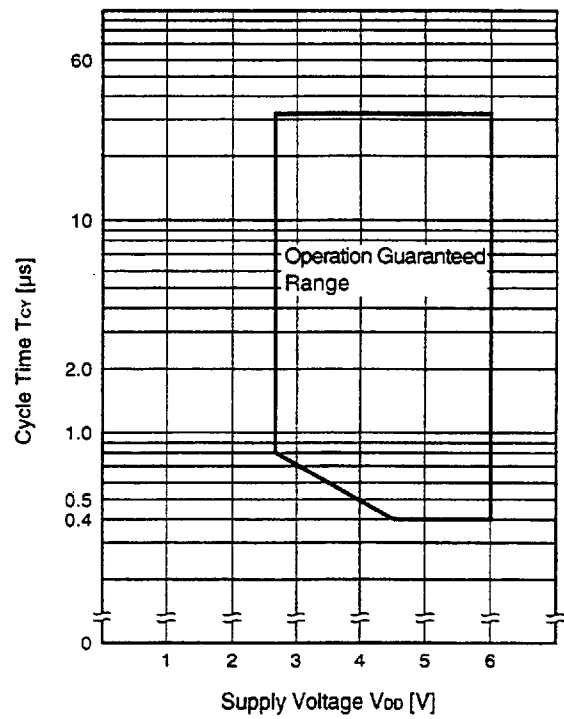

(2) READ/WRITE OPERATION

(a) When MCS = 1, PCC2 to PCC0 = 000B (T_A = -40 to +85 °C, V_{DD} = 4.5 to 6.0 V)

Parameter	Symbol	Test Conditions	MIN.	MAX.	Unit
ASTB high-level width	t _{ASTH}		0.85t _{cy} - 50		ns
Address setup time	t _{ADS}		0.85t _{cy} - 50		ns
Address hold time	t _{ADH}		50		ns
Data input time from address	t _{ADD1}			(2.85 + 2n)t _{cy} - 80	ns
	t _{ADD2}			(4 + 2n)t _{cy} - 100	ns
Data input time from $\overline{RD}\downarrow$	t _{RDD1}			(2 + 2n)t _{cy} - 100	ns
	t _{RDD2}			(2.85 + 2n)t _{cy} - 100	ns
Read data hold time	t _{RDH}		0		ns
\overline{RD} low-level width	t _{RDL1}		(2 + 2n)t _{cy} - 60		ns
	t _{RDL2}		(2.85 + 2n)t _{cy} - 60		ns
$\overline{WAIT}\downarrow$ input time from $\overline{RD}\downarrow$	t _{RDWT1}			0.85t _{cy} - 50	ns
	t _{RDWT2}			2t _{cy} - 60	ns
$\overline{WAIT}\downarrow$ input time from $\overline{WR}\downarrow$	t _{WRWT}			2t _{cy} - 60	ns
\overline{WAIT} low-level width	t _{WTL}		(1.15 + 2n)t _{cy}	(2 + 2n)t _{cy}	ns
Write data setup time	t _{WDS}		(2.85 + 2n)t _{cy} - 100		ns
Write data hold time	t _{WDH}		20		ns
\overline{WR} low-level width	t _{WRL}		(2.85 + 2n)t _{cy} - 60		ns
$\overline{RD}\downarrow$ delay time from $\overline{ASTB}\downarrow$	t _{ASTRD}		25		ns
$\overline{WR}\downarrow$ delay time from $\overline{ASTB}\downarrow$	t _{ASTWR}		0.85t _{cy} + 20		ns
ASTB \uparrow delay time from $\overline{RD}\uparrow$ in external fetch	t _{RDAST}		0.85t _{cy} - 10	1.15t _{cy} + 20	ns
Address hold time from $\overline{RD}\uparrow$ in external fetch	t _{RDADH}		0.85t _{cy} - 50	1.15t _{cy} + 50	ns
Write data output time from $\overline{RD}\uparrow$	t _{RWD}		40		ns
Write data output time from $\overline{WR}\downarrow$	t _{RWD}		0	50	ns
Address hold time from $\overline{WR}\uparrow$	t _{WRADH}		0.85t _{cy}	1.15t _{cy} + 40	ns
$\overline{RD}\uparrow$ delay time from $\overline{WAIT}\uparrow$	t _{WTRD}		1.15t _{cy} + 40	3.15t _{cy} + 40	ns
$\overline{WR}\uparrow$ delay time from $\overline{WAIT}\uparrow$	t _{WTWR}		1.15t _{cy} + 30	3.15t _{cy} + 30	ns

- Remarks
1. MCS: Oscillation mode selection register (OSMS) bit 0
 2. PCC2 to PCC0: Processor clock control register (PCC) bit 2 to bit 0
 3. t_{cy} = T_{cy}/4
 4. n indicates number of waits.

(b) Except when MCS = 1, PCC2 to PCC0 = 000B (T_A = -40 to +85 °C, V_{DD} = 2.0 to 6.0 V)

(1/2)

Parameter	Symbol	Test Conditions	MIN.	MAX.	Unit
ASTB high-level width	t _{ASTH}	V _{DD} = 2.7 to 6.0 V	t _{cy} - 80		ns
			t _{cy} - 150		ns
Address setup time	t _{ADS}	V _{DD} = 2.7 to 6.0 V	t _{cy} - 80		ns
			t _{cy} - 150		ns
Address hold time	t _{ADH}	V _{DD} = 2.7 to 6.0 V	0.4t _{cy} - 10		ns
			0.37t _{cy} - 40		ns
Data input time from address	t _{ADD1}	V _{DD} = 2.7 to 6.0 V		(3 + 2n)t _{cy} - 160	ns
				(3 + 2n)t _{cy} - 320	ns
	t _{ADD2}	V _{DD} = 2.7 to 6.0 V		(4 + 2n)t _{cy} - 200	ns
				(4 + 2n)t _{cy} - 300	ns
Data input time from $\overline{RD}\downarrow$	t _{RDD1}	V _{DD} = 2.7 to 6.0 V		(1.4 + 2n)t _{cy} - 70	ns
				(1.37 + 2n)t _{cy} - 120	ns
	t _{RDD2}	V _{DD} = 2.7 to 6.0 V		(2.4 + 2n)t _{cy} - 70	ns
				(2.37 + 2n)t _{cy} - 120	ns
Read data hold time	t _{RDH}		0		ns
RD low-level width	t _{RDL1}	V _{DD} = 2.7 to 6.0 V	(1.4 + 2n)t _{cy} - 20		ns
			(1.37 + 2n)t _{cy} - 20		ns
	t _{RDL2}	V _{DD} = 2.7 to 6.0 V	(2.4 + 2n)t _{cy} - 20		ns
			(2.37 + 2n)t _{cy} - 20		ns
WAIT \downarrow input time from $\overline{RD}\downarrow$	t _{RDWT1}	V _{DD} = 2.7 to 6.0 V		t _{cy} - 100	ns
				t _{cy} - 200	ns
	t _{RDWT2}	V _{DD} = 2.7 to 6.0 V		2t _{cy} - 100	ns
				2t _{cy} - 200	ns
WAIT \downarrow input time from $\overline{WR}\downarrow$	t _{WRWT}	V _{DD} = 2.7 to 6.0 V		2t _{cy} - 100	ns
				2t _{cy} - 200	ns
WAIT low-level width	t _{WTL}		(1 + 2n)t _{cy}	(2 + 2n)t _{cy}	ns
Write data setup time	t _{WDS}	V _{DD} = 2.7 to 6.0 V	(2.4 + 2n)t _{cy} - 60		ns
			(2.37 + 2n)t _{cy} - 100		ns
Write data hold time	t _{WDH}		20		ns
\overline{WR} low-level width	t _{WRL}	V _{DD} = 2.7 to 6.0 V	(2.4 + 2n)t _{cy} - 20		ns
			(2.37 + 2n)t _{cy} - 20		ns
$\overline{RD}\downarrow$ delay time from ASTB \downarrow	t _{ASTRD}	V _{DD} = 2.7 to 6.0 V	0.4t _{cy} - 30		ns
			0.37t _{cy} - 50		ns
$\overline{WR}\downarrow$ delay time from ASTB \downarrow	t _{ASTWR}	V _{DD} = 2.7 to 6.0 V	1.4t _{cy} - 30		ns
			1.37t _{cy} - 50		ns

- Remarks
1. MCS: Oscillation mode selection register (OSMS) bit 0
 2. PCC2 to PCC0: Processor clock control register (PCC) bit 2 to bit 0
 3. t_{cy} = T_{cy}/4
 4. n indicates the number of waits.

(b) Except when MCS = 1, PCC2 to PCC0 = 000B (T_A = -40 to +85 °C, V_{DD} = 2.0 to 6.0 V)

(2/2)

Parameter	Symbol	Test Conditions	MIN.	MAX.	Unit
ASTB↑ delay time from RD↑ in external fetch	tRDAST		t _{cy} - 10	t _{cy} + 20	ns
Address hold time from RD↑ in external fetch	tRDADH		t _{cy} - 50	t _{cy} + 50	ns
Write data output time from RD↑	tRDWD	V _{DD} = 2.7 to 6.0 V	0.4t _{cy} - 20		ns
			0.37t _{cy} - 40		ns
Write data output time from WR↓	tWRWD	V _{DD} = 2.7 to 6.0 V	0	60	ns
			0	120	ns
Address hold time from WR↑	tWRADH	V _{DD} = 2.7 to 6.0 V	t _{cy}	t _{cy} + 60	ns
			t _{cy}	t _{cy} + 120	ns
RD↑ delay time from WAIT↑	tWTRD	V _{DD} = 2.7 to 6.0 V	0.6t _{cy} + 180	2.6t _{cy} + 180	ns
			0.63t _{cy} + 350	2.63t _{cy} + 350	ns
WR↑ delay time from WAIT↑	tWTWR	V _{DD} = 2.7 to 6.0 V	0.6t _{cy} + 120	2.6t _{cy} + 120	ns
			0.63t _{cy} + 240	2.63t _{cy} + 240	ns

- Remarks**
1. MCS: Oscillation mode selection register (OSMS) bit 0
 2. PCC2 to PCC0: Processor clock control register (PCC) bit 2 to bit 0
 3. t_{cy} = T_{cy}/4
 4. n indicates number of waits.

(3) SERIAL INTERFACE (T_A = -40 to +85 °C, V_{DD} = 2.0 to 6.0 V)

(a) Serial interface channel 0

(i) 3-wire serial I/O mode ($\overline{\text{SCK0}}$... Internal clock output)

Parameter	Symbol	Test Conditions	MIN.	TYP.	MAX.	Unit
$\overline{\text{SCK0}}$ cycle time	t _{KCY1}	4.5 V ≤ V _{DD} ≤ 6.0 V	800			ns
		2.7 V ≤ V _{DD} < 4.5 V	1600			ns
			3200			ns
$\overline{\text{SCK0}}$ high-/low-level width	t _{KH1} , t _{KL1}	V _{DD} = 4.5 to 6.0 V	t _{KCY1} /2 - 50			ns
			t _{KCY1} /2 - 100			ns
SIO setup time (to $\overline{\text{SCK0}}\uparrow$)	t _{SIK1}	4.5 V ≤ V _{DD} ≤ 6.0 V	100			ns
		2.7 V ≤ V _{DD} < 4.5 V	150			ns
			300			ns
SIO hold time (from $\overline{\text{SCK0}}\uparrow$)	t _{KSH1}		400			ns
SO0 output delay time from $\overline{\text{SCK0}}\downarrow$	t _{KSO1}	C = 100 pF Note			300	ns

Note C is the load capacitance of $\overline{\text{SCK0}}$, SO0 output line.

(ii) 3-wire serial I/O mode ($\overline{\text{SCK0}}$... External clock input)

Parameter	Symbol	Test Conditions	MIN.	TYP.	MAX.	Unit
$\overline{\text{SCK0}}$ cycle time	t _{KCY2}	4.5 V ≤ V _{DD} ≤ 6.0 V	800			ns
		2.7 V ≤ V _{DD} < 4.5 V	1600			ns
			3200			ns
$\overline{\text{SCK0}}$ high-/low-level width	t _{KH2} , t _{KL2}	4.5 V ≤ V _{DD} ≤ 6.0 V	400			ns
		2.7 V ≤ V _{DD} < 4.5 V	800			ns
			1600			ns
SIO setup time (to $\overline{\text{SCK0}}\uparrow$)	t _{SIK2}		100			ns
SIO hold time (from $\overline{\text{SCK0}}\uparrow$)	t _{KSH2}		400			ns
SO0 output delay time from $\overline{\text{SCK0}}\downarrow$	t _{KSO2}	C = 100 pF Note			300	ns
$\overline{\text{SCK0}}$ rise, fall time	t _{R2} , t _{F2}	When using external device expansion function			160	ns
		When not using external device expansion function			1000	ns

Note C is the load capacitance of SO0 output line.

(iii) 2-wire serial I/O mode ($\overline{SCK0}$... Internal clock output)

Parameter	Symbol	Test Conditions	MIN.	TYP.	MAX.	Unit	
$\overline{SCK0}$ cycle time	t_{KCY3}	R = 1 kΩ, C = 100 pF Note	V _{DD} = 2.7 to 6.0 V	1600			ns
				3200			ns
$\overline{SCK0}$ high-level width	t_{KH3}		V _{DD} = 2.7 to 6.0 V	$t_{KCY3}/2 - 160$			ns
				$t_{KCY3}/2 - 190$			ns
$\overline{SCK0}$ low-level width	t_{KL3}		V _{DD} = 4.5 to 6.0 V	$t_{KCY3}/2 - 50$			ns
				$t_{KCY3}/2 - 100$			ns
SB0, SB1 setup time (to $\overline{SCK0}\uparrow$)	t_{SIK3}		4.5 V ≤ V _{DD} ≤ 6.0 V	300			ns
			2.7 V ≤ V _{DD} < 4.5 V	350			ns
				400			ns
SB0, SB1 hold time (from $\overline{SCK0}\uparrow$)	t_{HSI3}			600			ns
SB0, SB1 output delay time from $\overline{SCK0}\downarrow$	t_{KSO3}		0		300	ns	

Note R and C are the load resistance and load capacitance of the $\overline{SCK0}$, SB0, and SB1 output line.

(iv) 2-wire serial I/O mode ($\overline{SCK0}$... External clock input)

Parameter	Symbol	Test Conditions	MIN.	TYP.	MAX.	Unit	
$\overline{SCK0}$ cycle time	t_{KCY4}	V _{DD} = 2.7 to 6.0 V	1600			ns	
			3200			ns	
$\overline{SCK0}$ high-level width	t_{KH4}	V _{DD} = 2.7 to 6.0 V	650			ns	
			1300			ns	
$\overline{SCK0}$ low-level width	t_{KL4}	V _{DD} = 2.7 to 6.0 V	800			ns	
			1600			ns	
SB0, SB1 setup time (to $\overline{SCK0}\uparrow$)	t_{SIK4}		100			ns	
SB0, SB1 hold time (from $\overline{SCK0}\uparrow$)	t_{HSI4}		$t_{KCY4}/2$			ns	
SB0, SB1 output delay time from $\overline{SCK0}\downarrow$	t_{KSO4}	R = 1 kΩ, C = 100 pF Note	V _{DD} = 4.5 to 6.0 V	0		300	ns
				0		500	ns
$\overline{SCK0}$ rise, fall time	t_{R4}, t_{F4}	When using external device expansion function			160	ns	
		When not using external device expansion function			1000	ns	

Note R and C are the load resistance and load capacitance of the $\overline{SCK0}$, SB0, and SB1 output line.

(v) I²C Bus mode (SCL...Internal clock output)

Parameter	Symbol	Test Conditions		MIN.	TYP.	MAX.	Unit
SCL cycle time	t _{cy5}	R = 1 k Ω C = 100pF <i>Note</i>	V _{DD} = 2.7 to 6.0 V	10			μ s
				20			μ s
SCL high-level width	t _{chs}		V _{DD} = 2.7 to 6.0 V	t _{cy5} - 160			ns
				t _{cy5} - 190			ns
SCL low-level width	t _{cls}		V _{DD} = 4.5 to 6.0 V	t _{cy5} - 50			ns
				t _{cy5} - 100			ns
SDA0, SDA1 setup time (to SCL \uparrow)	t _{s1s}		V _{DD} = 2.7 to 6.0 V	200			ns
				300			ns
SDA0, SDA1 hold time (to SCL \downarrow)	t _{sis}			0			ns
SDA0, SDA1 output delay time from SCL \downarrow	t _{sos}		V _{DD} = 4.5 to 6.0 V	0		300	ns
				0		500	ns
SCL \uparrow →SDA0, SDA1 \downarrow or SCL \uparrow →SDA0, SDA1 \uparrow	t _{ssb}			200			ns
SDA0, SDA1 \downarrow →SCL \downarrow	t _{sak}			400			ns
SDA0, SDA1 high-level width	t _{sbH}			500			ns

Note R and C are the load resistance and load capacitance of the $\overline{SCK0}$, SB0, and SB1 output line.

(vi) I²C Bus mode (SCL...External clock input)

Parameter	Symbol	Test Conditions		MIN.	TYP.	MAX.	Unit
SCL cycle time	t _{cy6}			1000			ns
SCL high-/low-level width	t _{ch6}			400			ns
	t _{cl6}						
SDA0, SDA1 setup time (to SCL \uparrow)	t _{s16}			200			ns
SDA0, SDA1 hold time (to SCL \downarrow)	t _{s16}			0			ns
SCL \downarrow →SDA0, SDA1 output delay time	t _{sos6}	R = 1 k Ω , C = 100 pF <i>Note</i>	V _{DD} = 4.5 to 6.0 V	0		300	ns
				0		500	ns
SCL \uparrow →SDA0, SDA1 \downarrow or SCL \uparrow →SDA0, SDA1 \uparrow	t _{ssb6}			200			ns
SDA0, SDA1 \downarrow →SCL \downarrow	t _{sak6}			400			ns
SDA0, SDA1 high-level width	t _{sbH6}			500			ns
SCL rise, fall time	t _{re}	When using external device expansion function				160	ns
	t _{fe}	When not using external device expansion function				1000	ns

Note R and C are the load resistance and load capacitance of the SDA0, SDA1 output line.

(b) Serial interface channel 1

(i) 3-wire serial I/O mode ($\overline{\text{SCK1}}$... Internal clock output)

Parameter	Symbol	Test Conditions	MIN.	TYP.	MAX.	Unit
$\overline{\text{SCK1}}$ cycle time	t_{CY7}	$4.5 \text{ V} \leq V_{\text{DD}} \leq 6.0 \text{ V}$		800		ns
		$2.7 \text{ V} \leq V_{\text{DD}} < 4.5 \text{ V}$	1600			ns
			3200			ns
$\overline{\text{SCK1}}$ high-/low-level width	t_{KH7}	$V_{\text{DD}} = 4.5 \text{ to } 6.0 \text{ V}$	$t_{\text{CY7}}/2 - 50$			ns
	t_{KL7}		$t_{\text{CY7}}/2 - 100$			ns
SI1 setup time (to $\overline{\text{SCK1}}\uparrow$)	t_{SIK7}	$4.5 \text{ V} \leq V_{\text{DD}} \leq 6.0 \text{ V}$	100			ns
		$2.7 \text{ V} \leq V_{\text{DD}} < 4.5 \text{ V}$	150			ns
			300			ns
SI1 hold time (from $\overline{\text{SCK1}}\uparrow$)	t_{SH7}		400			ns
SO1 output delay time from $\overline{\text{SCK1}}\downarrow$	t_{SO7}	$C = 100 \text{ pF}$ ^{Note}			300	ns

Note C is the load capacitance of the $\overline{\text{SCK1}}$ and SO1 output lines.

(ii) 3-wire serial I/O mode ($\overline{\text{SCK1}}$... External clock input)

Parameter	Symbol	Test Conditions	MIN.	TYP.	MAX.	Unit
$\overline{\text{SCK1}}$ cycle time	t_{CY8}	$4.5 \text{ V} \leq V_{\text{DD}} \leq 6.0 \text{ V}$	800			ns
		$2.7 \text{ V} \leq V_{\text{DD}} < 4.5 \text{ V}$	1600			ns
			3200			ns
$\overline{\text{SCK1}}$ high-/low-level width	t_{KH8}	$4.5 \text{ V} \leq V_{\text{DD}} \leq 6.0 \text{ V}$	400			ns
	t_{KL8}	$2.7 \text{ V} \leq V_{\text{DD}} < 4.5 \text{ V}$	800			ns
			1600			ns
SI1 setup time (to $\overline{\text{SCK1}}\uparrow$)	t_{SI8}		100			ns
SI1 hold time (from $\overline{\text{SCK1}}\uparrow$)	t_{SH8}		400			ns
SO1 output delay time from $\overline{\text{SCK1}}\downarrow$	t_{SO8}	$C = 100 \text{ pF}$ ^{Note}			300	ns
$\overline{\text{SCK1}}$ rise, fall time	t_{r8}	When using external device expansion function			160	ns
	t_{f8}	When not using external device expansion function			1000	ns

Note C is the load capacitance of the SO1 output line.

(iii) 3-wire serial I/O mode with automatic transmit/receive function ($\overline{\text{SCK1}}$...Internal clock output)

Parameter	Symbol	Test Conditions	MIN.	TYP.	MAX.	Unit
$\overline{\text{SCK1}}$ cycle time	t_{KCY9}	$4.5 \text{ V} \leq V_{\text{DD}} \leq 6.0 \text{ V}$	800			ns
		$2.7 \text{ V} \leq V_{\text{DD}} < 4.5 \text{ V}$	1600			ns
			3200			ns
$\overline{\text{SCK1}}$ high-/low-level width	$t_{\text{KH9}}, t_{\text{KL9}}$	$V_{\text{DD}} = 4.5 \text{ to } 6.0 \text{ V}$	$t_{\text{KCY9}}/2 - 50$			ns
			$t_{\text{KCY9}}/2 - 100$			ns
SI1 setup time (to $\overline{\text{SCK1}}\uparrow$)	t_{SIK9}	$4.5 \text{ V} \leq V_{\text{DD}} \leq 6.0 \text{ V}$	100			ns
		$2.7 \text{ V} \leq V_{\text{DD}} < 4.5 \text{ V}$	150			ns
			300			ns
SI1 hold time (from $\overline{\text{SCK1}}\uparrow$)	t_{KSI9}		400			ns
SO1 output delay time from $\overline{\text{SCK1}}\downarrow$	t_{KSO9}	$C = 100 \text{ pF}$ <small>Note</small>			300	ns
STB \uparrow from $\overline{\text{SCK1}}\uparrow$	t_{SBO}		$t_{\text{KCY9}}/2 - 100$		$t_{\text{KCY9}}/2 + 100$	ns
Strobe signal high-level width	t_{SW}	$V_{\text{DD}} = 2.7 \text{ to } 6.0 \text{ V}$	$t_{\text{KCY9}} - 30$		$t_{\text{KCY9}} + 30$	ns
			$t_{\text{KCY9}} - 60$		$t_{\text{KCY9}} + 60$	ns
Busy signal setup time (to busy signal detection timing)	t_{BYS}		100			ns
Busy signal hold time (from busy signal detection timing)	t_{BYH}	$4.5 \text{ V} \leq V_{\text{DD}} \leq 6.0 \text{ V}$	100			ns
		$2.7 \text{ V} \leq V_{\text{DD}} < 4.5 \text{ V}$	150			ns
			200			ns
$\overline{\text{SCK1}}\downarrow$ from busy inactive	t_{SPS}				$2t_{\text{KCY9}}$	ns

Note C is the load capacitance of the $\overline{\text{SCK1}}$, SO1 output line.

(iv) 3-wire serial I/O mode with automatic transmit/receive function ($\overline{\text{SCK1}}$...External clock input)

Parameter	Symbol	Test Conditions	MIN.	TYP.	MAX.	Unit
$\overline{\text{SCK1}}$ cycle time	t_{KCY10}	$4.5 \text{ V} \leq V_{\text{DD}} \leq 6.0 \text{ V}$	800			ns
		$2.7 \text{ V} \leq V_{\text{DD}} < 4.5 \text{ V}$	1600			ns
			3200			ns
$\overline{\text{SCK1}}$ high-/low-level width	$t_{\text{KH10}}, t_{\text{KL10}}$	$4.5 \text{ V} \leq V_{\text{DD}} \leq 6.0 \text{ V}$	400			ns
		$2.7 \text{ V} \leq V_{\text{DD}} < 4.5 \text{ V}$	800			ns
			1600			ns
SI1 setup time (to $\overline{\text{SCK1}}\uparrow$)	t_{SIK10}		100			ns
SI1 hold time (from $\overline{\text{SCK1}}\uparrow$)	t_{KIS10}		400			ns
SO1 output delay time from $\overline{\text{SCK1}}\downarrow$	t_{KSO10}	$C = 100 \text{ pF}$ <small>Note</small>			300	ns
$\overline{\text{SCK1}}$ rise, fall time	$t_{\text{R10}}, t_{\text{F10}}$	When using external device expansion function			160	ns
		When not using external device expansion function			1000	ns

Note C is the load capacitance of the SO1 output line.

(c) Serial interface channel 2

(i) 3-wire serial I/O mode ($\overline{\text{SCK2}}$... Internal clock output)

Parameter	Symbol	Test Conditions	MIN.	TYP.	MAX.	Unit
$\overline{\text{SCK2}}$ cycle time	t_{CY11}	$4.5 \text{ V} \leq V_{\text{DD}} \leq 6.0 \text{ V}$	800			ns
		$2.7 \text{ V} \leq V_{\text{DD}} < 4.5 \text{ V}$	1600			ns
			3200			ns
$\overline{\text{SCK2}}$ high-/low-level width	t_{H11}	$V_{\text{DD}} = 4.5 \text{ to } 6.0 \text{ V}$	$t_{\text{CY11}}/2 - 50$			ns
	t_{L11}		$t_{\text{CY11}}/2 - 100$			ns
SI2 setup time (to $\overline{\text{SCK2}}\uparrow$)	t_{SIK11}	$4.5 \text{ V} \leq V_{\text{DD}} \leq 6.0 \text{ V}$	100			ns
		$2.7 \text{ V} \leq V_{\text{DD}} < 4.5 \text{ V}$	150			ns
			300			ns
SI2 hold time (to $\overline{\text{SCK2}}\uparrow$)	t_{SH11}		400			ns
SO2 output delay time from $\overline{\text{SCK2}}\downarrow$	t_{SO11}	$C = 100 \text{ pF}$ ^{Note}			300	ns

Note C is the load capacitance of the $\overline{\text{SCK2}}$, SO2 output line.

(ii) 3-wire serial I/O mode ($\overline{\text{SCK2}}$... External clock input)

Parameter	Symbol	Test Conditions	MIN.	TYP.	MAX.	Unit
$\overline{\text{SCK2}}$ cycle time	t_{CY12}	$4.5 \text{ V} \leq V_{\text{DD}} \leq 6.0 \text{ V}$	800			ns
		$2.7 \text{ V} \leq V_{\text{DD}} < 4.5 \text{ V}$	1600			ns
			3200			ns
$\overline{\text{SCK2}}$ high-/low-level width	t_{H12}	$4.5 \text{ V} \leq V_{\text{DD}} \leq 6.0 \text{ V}$	400			ns
	t_{L12}	$2.7 \text{ V} \leq V_{\text{DD}} < 4.5 \text{ V}$	800			ns
			1600			ns
SI2 setup time (to $\overline{\text{SCK2}}\uparrow$)	t_{SIK12}		100			ns
SI2 hold time (from $\overline{\text{SCK2}}\uparrow$)	t_{SH12}		400			ns
SO2 output delay time from $\overline{\text{SCK2}}\downarrow$	t_{SO12}	$C = 100 \text{ pF}$ ^{Note}			300	ns
$\overline{\text{SCK2}}$ rise, fall time	t_{R12}	$V_{\text{DD}} = 4.5 \text{ to } 6.0 \text{ V}$,			1000	ns
	t_{F12}	When not using external device expansion function			160	ns

Note C is the load capacitance of the SO2 output line.

(iii) UART mode (Dedicated baud rate generator output)

Parameter	Symbol	Test Conditions	MIN.	TYP.	MAX.	Unit
Transfer rate		4.5 V ≤ V _{DD} ≤ 6.0 V			78125	bps
		2.7 V ≤ V _{DD} < 4.5 V			39063	bps
					19531	bps

(iv) UART mode (External clock input)

Parameter	Symbol	Test Conditions	MIN.	TYP.	MAX.	Unit
ASCK cycle time	t _{CKY13}	4.5 V ≤ V _{DD} ≤ 6.0 V	800			ns
		2.7 V ≤ V _{DD} < 4.5 V	1600			ns
			3200			ns
ASCK high-/low-level width	t _{DH13} , t _{DL13}	4.5 V ≤ V _{DD} ≤ 6.0 V	400			ns
		2.7 V ≤ V _{DD} < 4.5 V	800			ns
			1600			ns
Transfer rate		4.5 V ≤ V _{DD} ≤ 6.0 V			39063	bps
		2.7 V ≤ V _{DD} < 4.5 V			19531	bps
					9766	bps
ASCK rise, fall time	t _{R13} , t _{F13}	V _{DD} = 4.5 to 6.0 V, when not using external device expansion function.			1000	ns
					160	ns

AC Timing Test Point (Excluding X1, XT1 Input)



Clock Timing

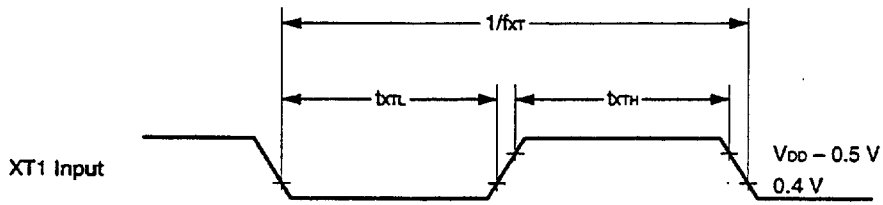
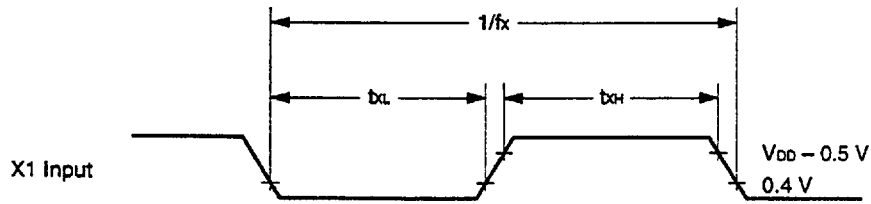

T1 Timing

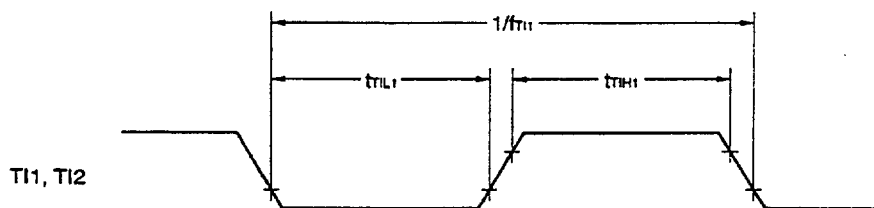
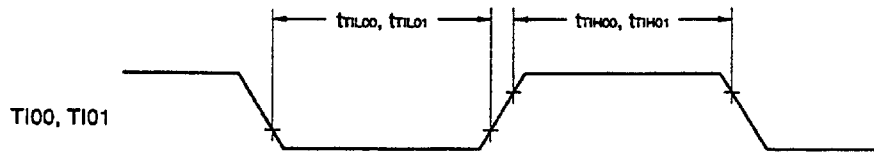

Read/Write Operation

External Fetch (No Wait) :

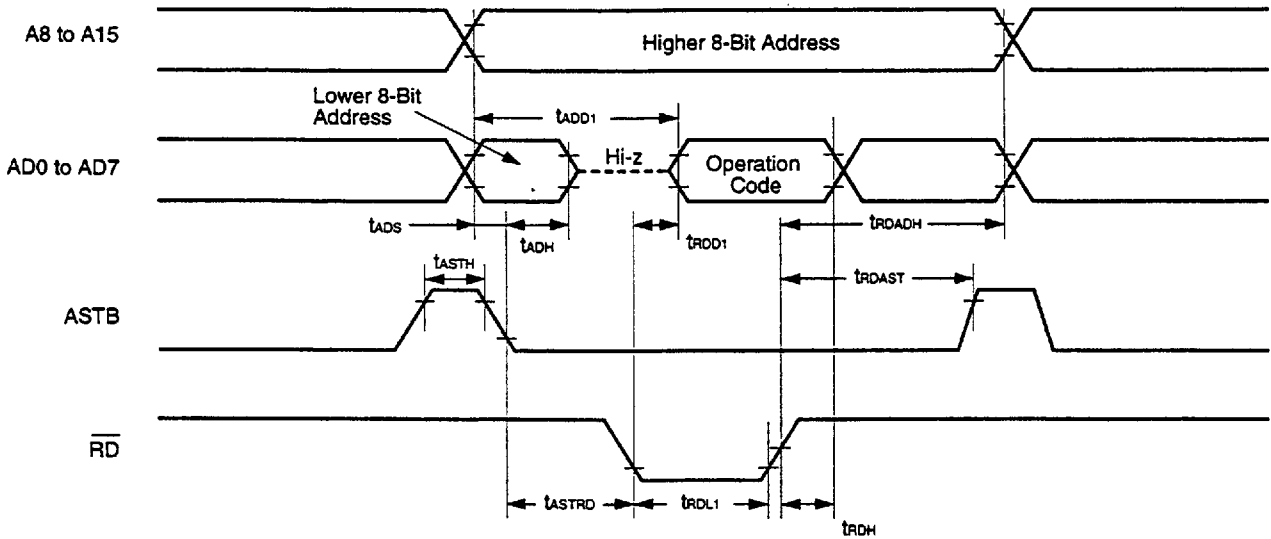

External Fetch (Wait Insertion) :

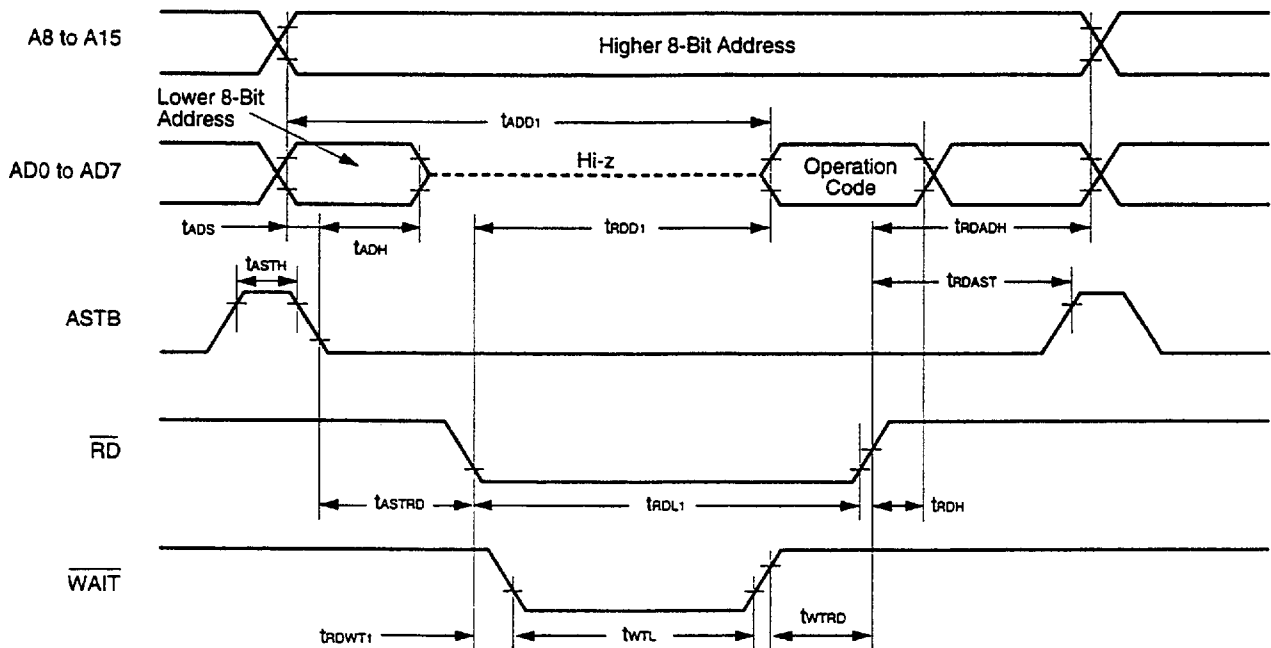

External Data Access (No Wait) :

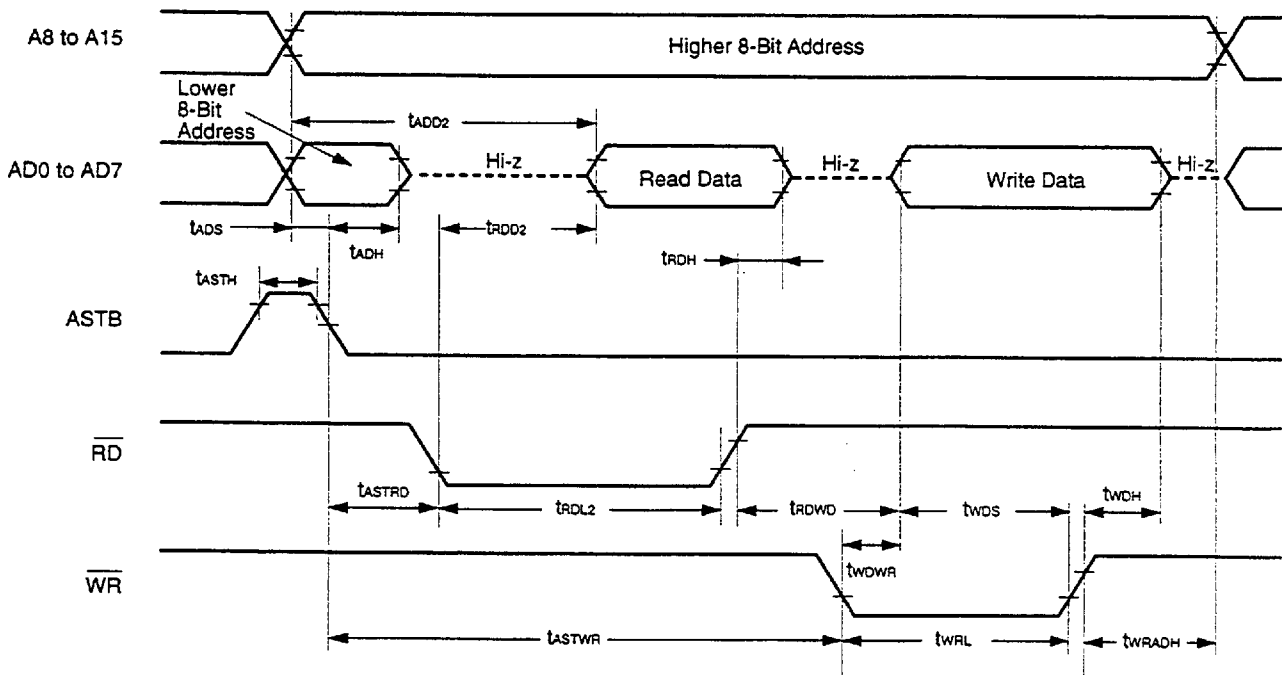

External Data Access (Wait Insertion) :

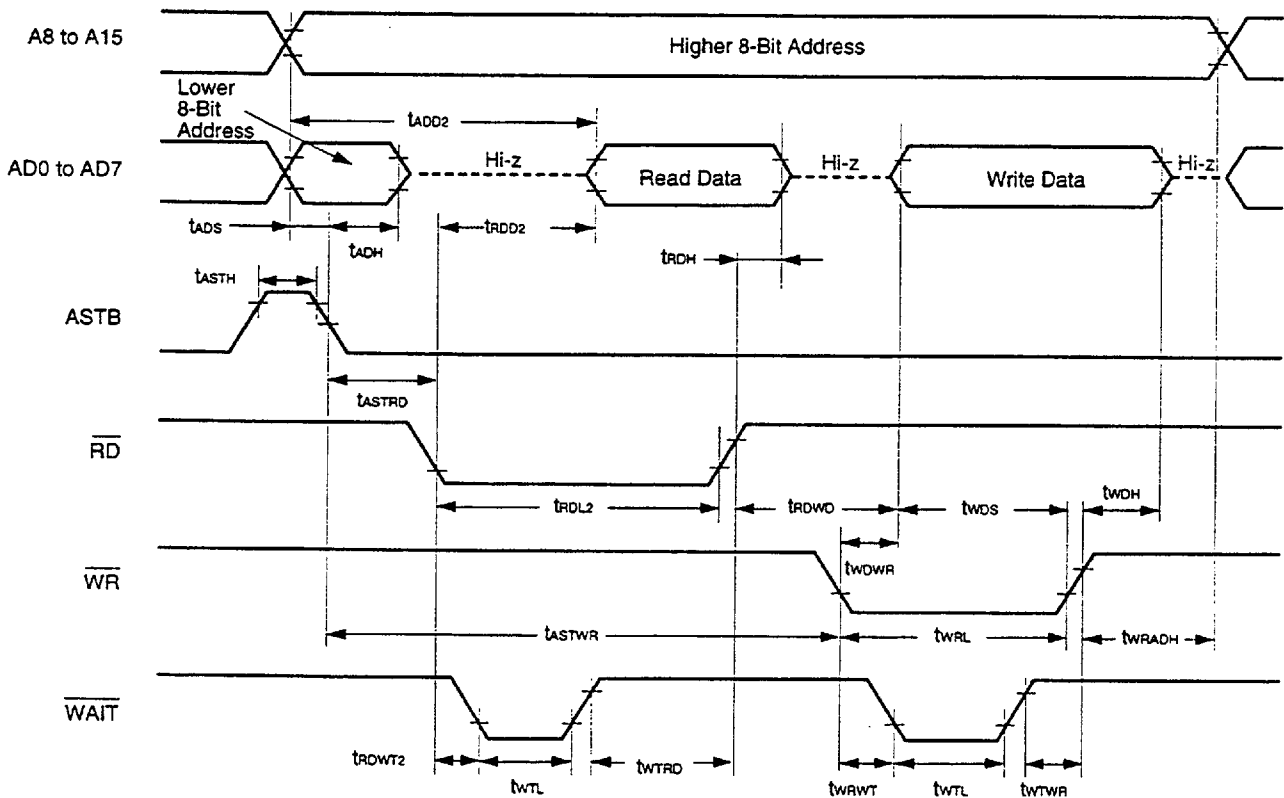

Serial Transfer Timing

3-wire Serial I/O Mode :

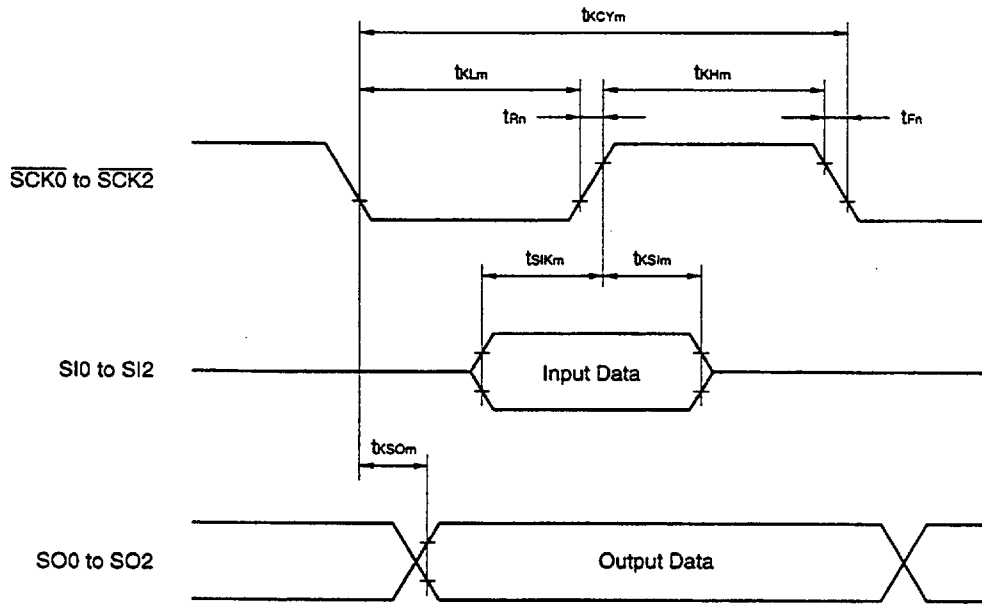

$m = 1, 2, 7, 8, 11, 12$

$n = 2, 8, 12$

2-wire Serial I/O Mode :

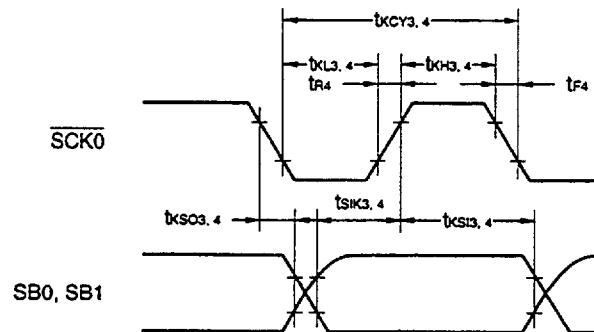

I²C Bus Mode:

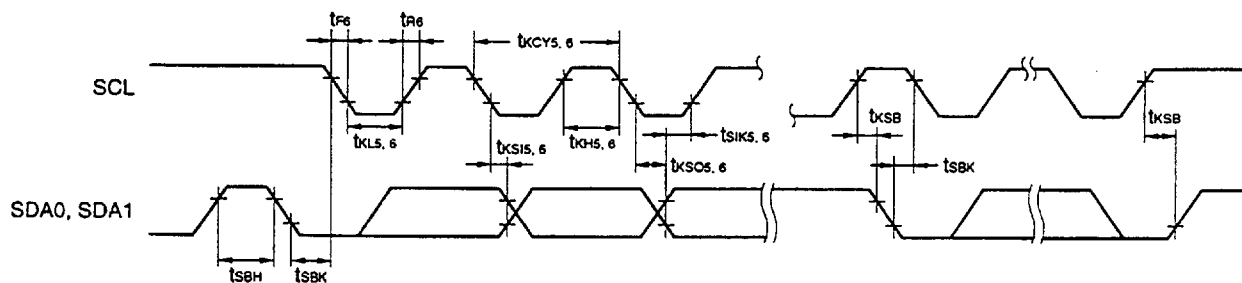

3-wire Serial I/O Mode with Automatic Transmit/Receive Function :

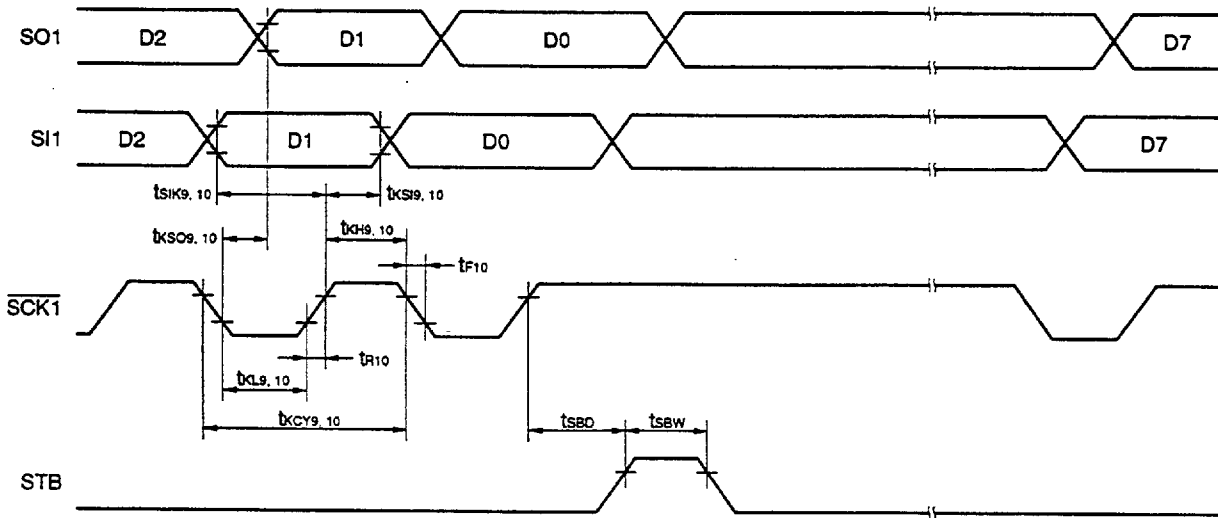

3-wire Serial I/O Mode with Automatic Transmit/Receive Function (Busy Processing) :

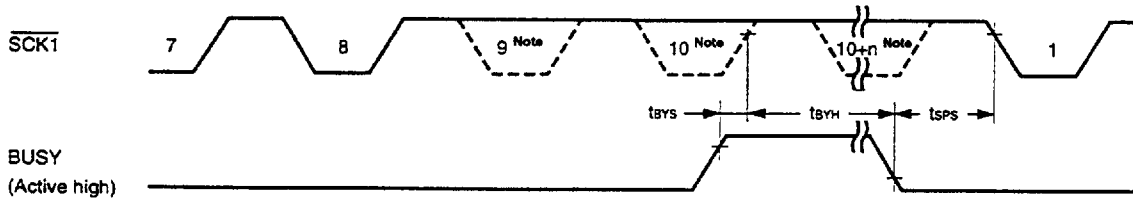

Note The signal is not actually driven low here; it is shown as such to indicate the timing.

UART Mode (External Clock Input) :

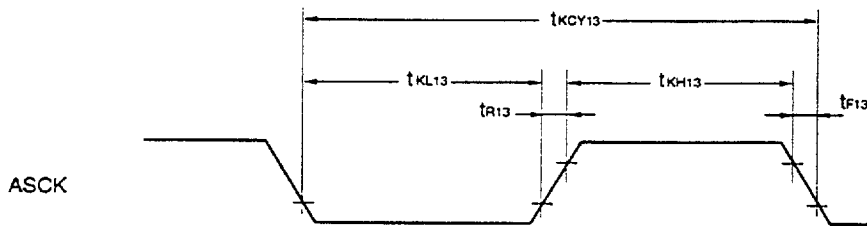

A/D CONVERTER CHARACTERISTICS (T_A = -40 to +85 °C, AV_{DD} = V_{DD} = 2.0 to 6.0 V, AV_{SS} = V_{SS} = 0 V)

Parameter	Symbol	Test Conditions	MIN.	TYP.	MAX.	Unit
Resolution			8	8	8	bit
Overall error <i>Note</i>		2.7 V ≤ AV _{REF0} ≤ AV _{DD}			0.6	%
		2.0 V ≤ AV _{REF0} < 2.7 V			1.4	%
Conversion time	t _{CONV}		19.1		200	μs
Sampling time	t _{SAMP}		12/f _{xx}			μs
Analog input voltage	V _{IAN}		AV _{SS}		AV _{REF0}	V
Reference voltage	AV _{REF0}		2.0		AV _{DD}	V
Resistance between AV _{REF0} and AV _{SS}	R _{AIREF0}		4	14		kΩ

Note Overall error excluding quantization error (±1/2 LSB). It is indicated as a ratio to the full-scale value.

f_{xx} : Main system clock frequency (f_x or f_x/2)

f_x : Main system clock oscillation frequency

D/A CONVERTER CHARACTERISTICS (T_A = -40 to +85 °C, V_{DD} = 2.0 to 6.0 V, AV_{SS} = V_{SS} = 0 V)

Parameter	Symbol	Test Conditions	MIN.	TYP.	MAX.	Unit
Resolution					8	bit
Overall error		R = 2 MΩ <i>Note1</i>			1.2	%
		R = 4 MΩ <i>Note1</i>			0.8	%
		R = 10 MΩ <i>Note1</i>			0.6	%
Settling time		C=30pF <i>Note1</i>	4.5 V ≤ AV _{REF1} ≤ 6.0 V		10	μs
			2.7 V ≤ AV _{REF1} < 4.5 V		15	μs
			2.0 V ≤ AV _{REF1} < 2.7 V		20	μs
Output resistance	R _O	DACS0, DACS1 = 55H <i>Note 2</i>		10		kΩ
Analog reference voltage	AV _{REF1}		2.0		V _{DD}	V
AV _{REF1} current	I _{REF1}	<i>Note2</i>			1.5	mA

Notes 1. R and C denote D/A converter output pin load resistance and load capacitance, respectively.

2. Value for one D/A converter channel

DACS0, DACS1: D/A conversion value setting register.

DATA MEMORY STOP MODE LOW SUPPLY VOLTAGE DATA RETENTION CHARACTERISTICS (T_A = -40 to +85°C)

Parameter	Symbol	Test Conditions	MIN.	TYP.	MAX.	Unit
Data retention power supply voltage	V _{DDDR}		1.8		6.0	V
Data retention power supply current	I _{DDDR}	V _{DDDR} = 1.8 V Subsystem clock stop and feedback resistor disconnected		0.1	10	μA
Release signal set time	t _{SREL}		0			μs
Oscillation stabiliation wait time	t _{WAIT}	Release by $\overline{\text{RESET}}$		2 ¹⁷ /f _x		ms
		Release by interrupt		Note		ms

Note In combination with bits 0 to 2 (OSTS0 to OSTS2) of oscillation stabilization time selection register (OSTS), selection of 2¹²/f_{xx} and 2¹⁴/f_{xx} to 2¹⁷/f_{xx} is possible.

f_{xx} : Main system clock frequency (f_x or f_x/2)

f_x : Main system clock oscillation frequency

Data Retention Timing (STOP Mode Release by $\overline{\text{RESET}}$)

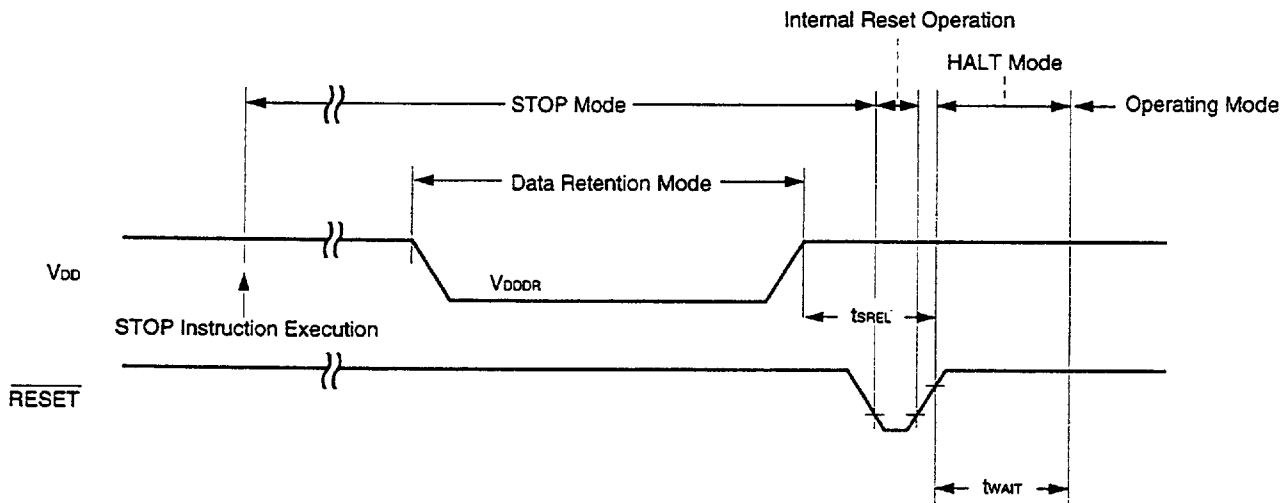

Data Retention Timing (Standby Release Signal: STOP Mode Release by Interrupt Signal)

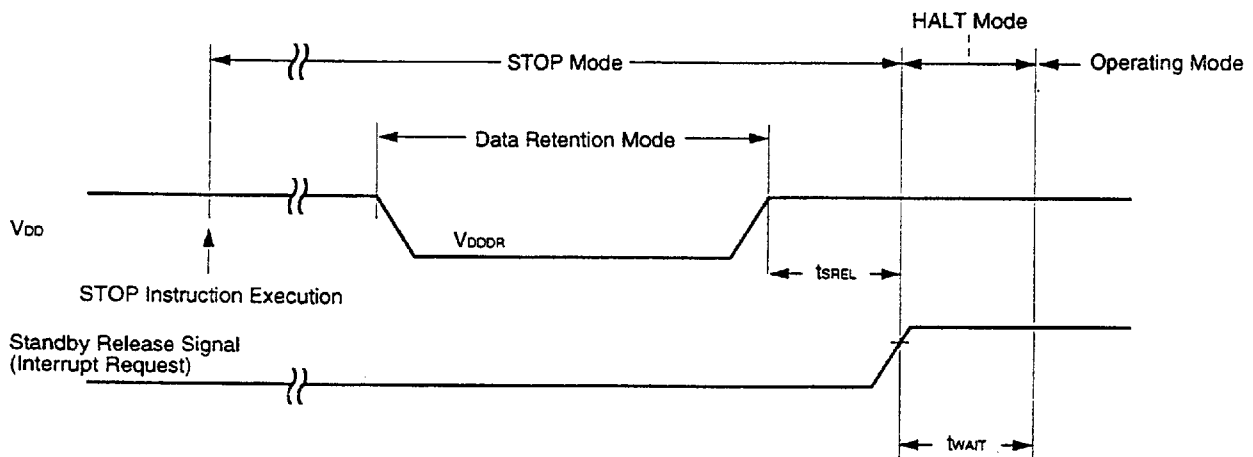

Interrupt Input Timing

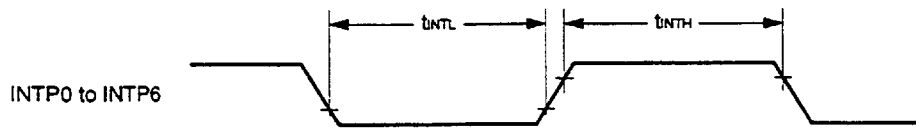

$\overline{\text{RESET}}$ Input Timing

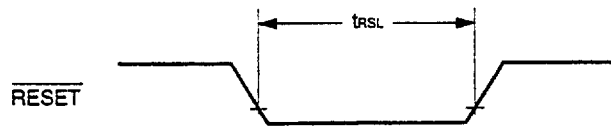

12. CHARACTERISTIC CURVES (REFERENCE VALUE)

*

I_{DD} vs V_{DD} ($f_x = f_{XX} = 5.0$ MHz)

($T_A = 25$ °C)

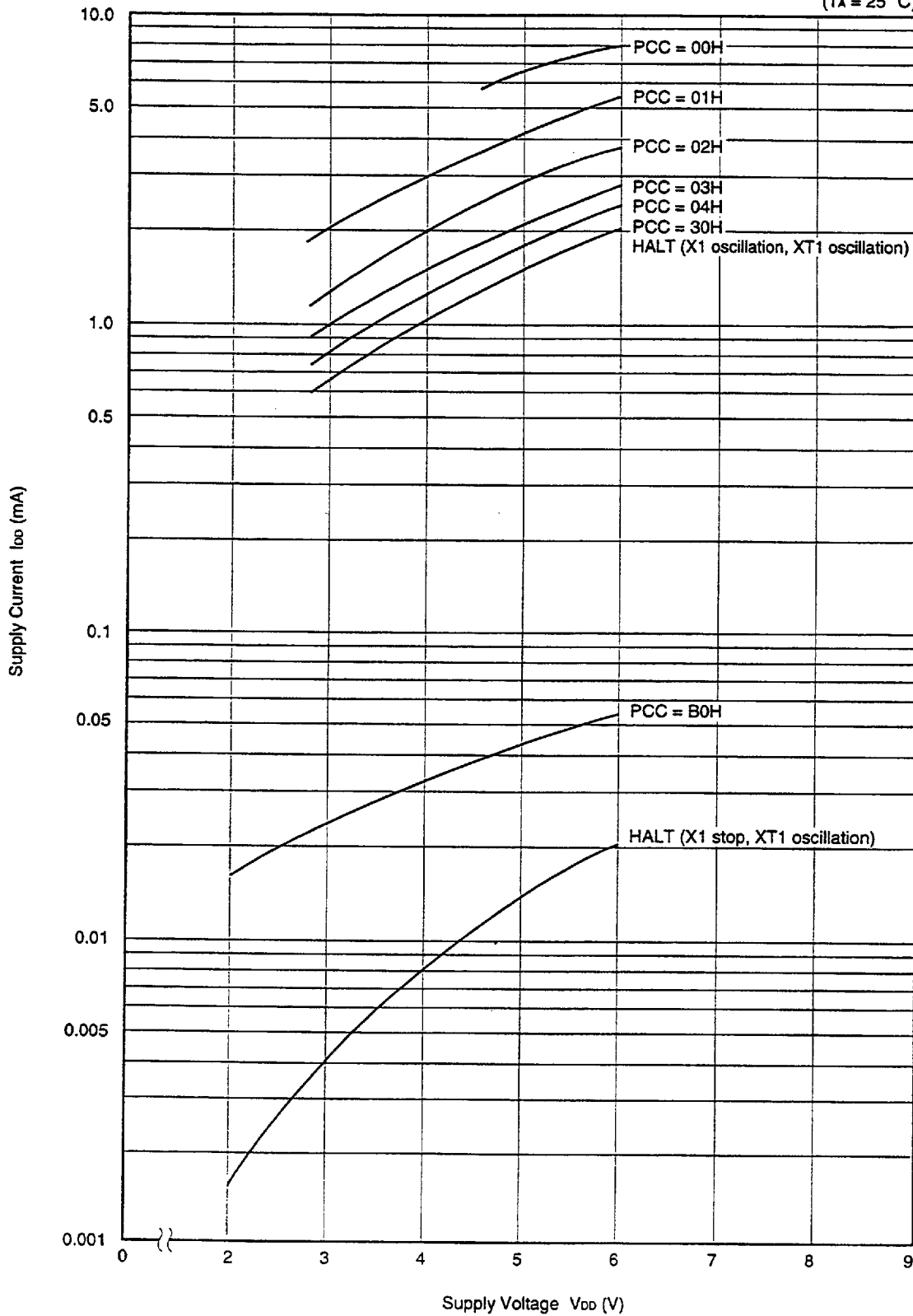

I_{DD} vs V_{DD} (f_x = 5.0 MHz, f_{xx} = 2.5 MHz)

(T_A = 25 °C)

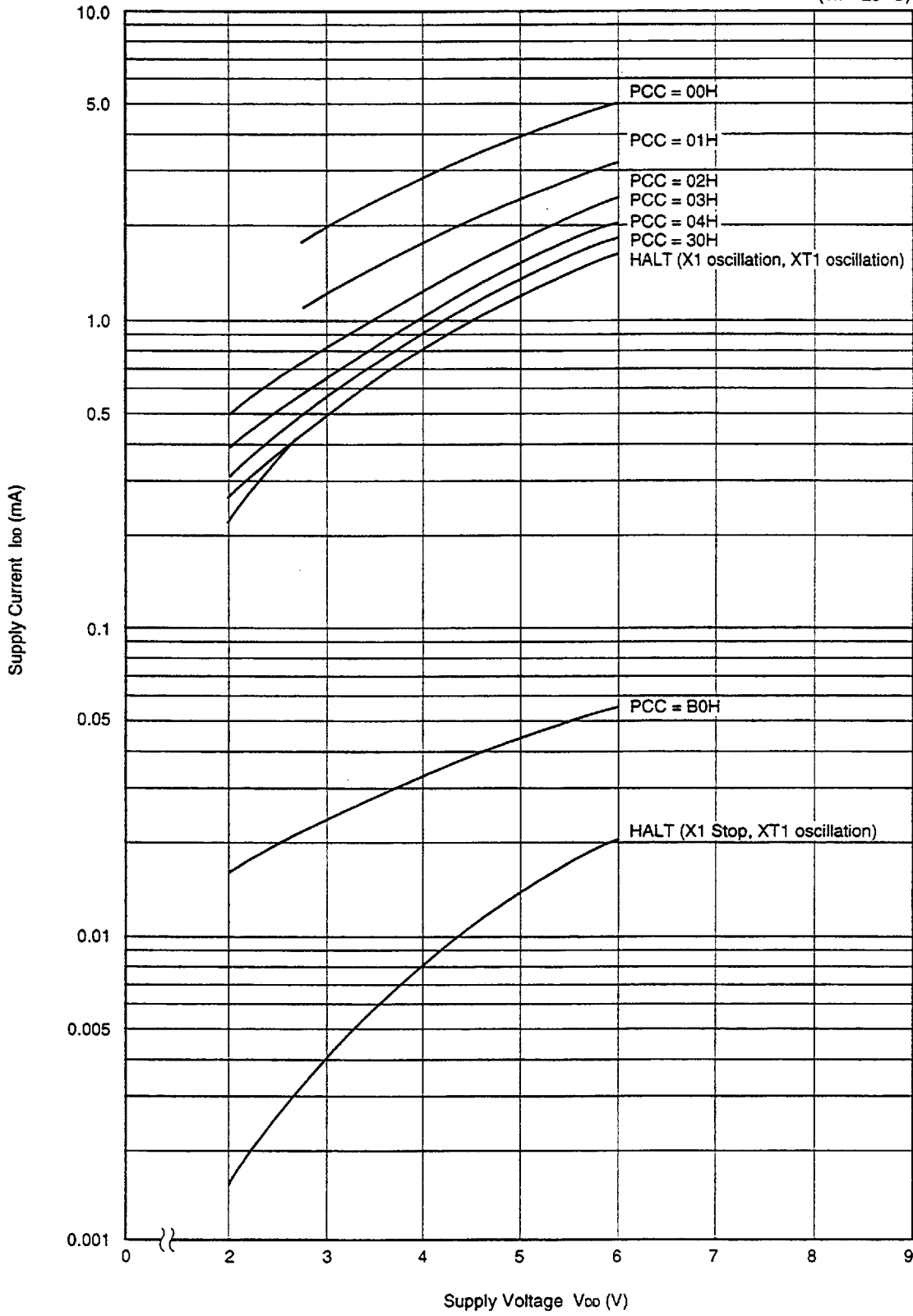

13. PACKAGE DRAWING

80 PIN PLASTIC QFP (□14)

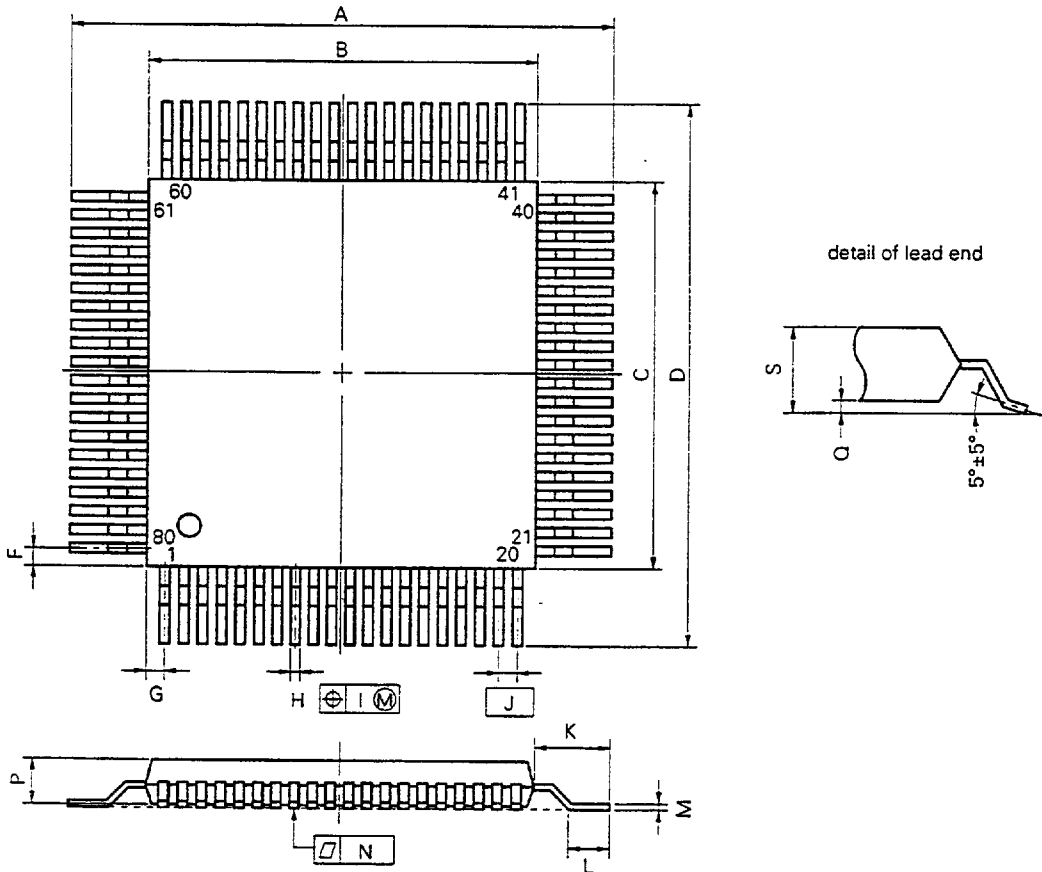

NOTE
 Each lead centerline is located within 0.13 mm (0.005 inch) of its true position (T.P.) at maximum material condition.

S80GC-65-3B9-3

ITEM	MILLIMETERS	INCHES
A	17.2±0.4	0.677±0.016
B	14.0±0.2	0.551 ^{+0.009} _{-0.008}
C	14.0±0.2	0.551 ^{+0.009} _{-0.008}
D	17.2±0.4	0.677±0.016
F	0.8	0.031
G	0.8	0.031
H	0.30±0.10	0.012 ^{+0.004} _{-0.005}
I	0.13	0.005
J	0.65 (T.P.)	0.026 (T.P.)
K	1.6±0.2	0.063±0.008
L	0.8±0.2	0.031 ^{+0.009} _{-0.008}
M	0.15 ^{+0.10} _{-0.05}	0.006 ^{+0.004} _{-0.003}
N	0.10	0.004
P	2.7	0.106
Q	0.1±0.1	0.004±0.004
S	3.0 MAX.	0.119 MAX.

Remark Dimensions and materials of ES product are the same as those of mass-production products.

★

★ 14. RECOMMENDED SOLDERING CONDITIONS

This product should be soldered and mounted under the conditions recommended in the table below.

For a detailed description of recommended soldering conditions, refer to the information document "Semiconductor Device Mounting Technology Manual" (IEI-1207).

For soldering methods and conditions other than those recommended below, contact an NEC sales representative.

Table 14-1. Surface Mounting Type Soldering Conditions (1/2)

- (1) μPD78052YGC-xxx-3B9 : 80-pin plastic QFP (14 x 14 mm)
- μPD78053YGC-xxx-3B9 : 80-pin plastic QFP (14 x 14 mm)
- μPD78054YGC-xxx-3B9 : 80-pin plastic QFP (14 x 14 mm)
- μPD78055YGC-xxx-3B9 : 80-pin plastic QFP (14 x 14 mm)

Soldering Method	Soldering Conditions	Recommended Condition Symbol
Infrared reflow	Package peak temperature: 235 °C, Duration: 30 sec. max. (at 210 °C or above), Number of times: Twice max. <precautions> (1) Wait for the device temperature to come down to room temperature after the first reflow before starting the second reflow. (2) Do not perform flux washing of the soldered portion after the first reflow.	IR35-00-2
VPS	Package peak temperature: 215 °C, Duration: 40 sec. max. (at 200 °C or above), Number of times: Twice max. <precautions> (1) Wait for the device temperature to come down to room temperature after the first reflow before starting the second reflow. (2) Do not perform flux washing of the soldered portion after the first reflow.	VP15-00-2
Partial heating	Pin temperature: 300 °C max. Duration: 3 sec. max. (per pin row)	—

Caution Avoid as much as possible combining two or more soldering methods (except for the partial heating method).

Table 14-1. Surface Mounting Type Soldering Conditions (2/2)

- (2) μPD78056YGC-xxx-3B9 : 80-pin plastic QFP (14 x 14 mm)
- μPD78058YGC-xxx-3B9 : 80-pin plastic QFP (14 x 14 mm)

Soldering Method	Soldering Conditions	Recommended Condition Symbol
Infrared reflow	Package peak temperature: 235 °C, Duration: 30 sec. max. (at 210 °C or above), Number of times: Twice max. <precautions> (1) Wait for the device temperature to come down to room temperature after the first reflow before starting the second reflow. (2) Do not perform flux washing of the soldered portion after the first reflow.	IR35-00-2
VPS	Package peak temperature: 215 °C, Duration: 40 sec. max. (at 200 °C or above), Number of times: Twice max. <precautions> (1) Wait for the device temperature to come down to room temperature after the first reflow before starting the second reflow. (2) Do not perform flux washing of the soldered portion after the first reflow.	VP15-00-2
Wave soldering	Solder bath temperature : 260 °C max., Duration : 10 sec. max., Number of times: once, Preheating temperature : 120 °C max. (package surface temperature)	WS60-00-1
Partial heating	Pin temperature: 300 °C max. Duration: 3 sec. max. (per pin row)	—

Caution Avoid as much as possible combining two or more soldering methods (except for the partial heating method).

APPENDIX A. DEVELOPMENT TOOLS

The following development tools are available for system development using μPD78054Y subseries.

Language Processing Software

RA78K/0 Notes 1, 2, 3, 4	78K/0 series common assembler package
CC78K/0 Notes 1, 2, 3, 4	78K/0 series common C compiler package
DF78054 Notes 1, 2, 3, 4	Device file common to μPD78054 subseries
CC78K/0-L Notes 1, 2, 3, 4	78K/0 series common C compiler library source file

PROM Writing Tools

PG-1500	PROM programmer
PA-78P054GC PA-78P054KK-T	Programmer adapters connected to PG-1500
PG-1500 controller Notes 1, 2	PG-1500 control program

Debugging Tools

★

IE-78000-R	In-circuit emulator common to 78K/0 series
IE-78000-R-A Note 8	In-circuit emulator common to 78K/0 series (for integrated debugger)
IE-78000-R-BK	Break board common to 78K/0 series
IE-78064-R-EM	Emulation board common to μPD78064 subseries
EP-78230GC-R	Emulation probe common to μPD78234 subseries
EV-9200GC-80	Socket to be mounted in the target system board manufactured for 80-pin plastic QFP
SM78K0 Notes 5, 6, 7	System simulator common to 78K/0 series
ID78K0 Notes 4, 5, 6, 7, 8	Integrated debugger for IE-78000-R-A
SD78K/0 Notes 1, 2	Screen debugger for IE-78000-R
DF78054 Notes 1, 2, 5, 6, 7	Device file common to μPD78054 subseries

★

★

Real-Time OS

RX78K/0 Notes 1, 2, 3, 4	Real-time OS for 78K/0 series
MX78K0 Notes 1, 2, 3, 4	OS for 78K/0 series

★

Notes 1. PC-9800 series (MS-DOS™) based

2. IBM PC/AT™ and compatible computer (PC DOS™/IBM DOS™/MS-DOS) based

3. HP9000 Series 300™ (HP-UX™) based

4. HP9000 Series 700™ (HP-UX) based, SPARCstation™ (Sun OS™) based, EWS4800 Series (EWS-UX/V) based

5. PC-9800 Series (MS-DOS + Windows™) based

6. IBM PC/AT and compatible computer (PC DOS/IBM DOS/MS-DOS + Windows) based

7. NEWS™ (NEWS-OS™) based

8. Under development

Fuzzy Inference Development Support System

FE9000 <i>Note 1</i> / FE9200 <i>Note 2</i>	Fuzzy knowledge data creation tool
FT9080 <i>Note 1</i> / FT9085 <i>Note 3</i>	Translator
FI78K0 <i>Notes 1, 3</i>	Fuzzy inference module
FD78K0 <i>Notes 1, 3</i>	Fussy inference debugger

Notes 1. PC-9800 series (MS-DOS) based

2. IBM PC/AT and its compatible computers (PC DOS/IBM DOS/MS-DOS + Windows) based

3. IBM PC/AT and its compatible computers (PC DOS/IBM DOS/MS-DOS) based

Remarks 1. For third party development tools, see the **78K/0 Series Selection Guide (IF-1185)**.

2. RA78K/0, CC78K/0, SM78K0, ID78K0, and SD78K/0 are used in combination with DF78054.

* APPENDIX B. RELATED DOCUMENTS

Device Related Documents

Document Name		Document No. (Japanese)	Document No. (English)
μPD78054 and μPD78054Y Subseries User's Manual		IEU-824	IEU-1356
78K/0 Series User's Manual Instructions		IEU-849	IEU-1372
78K/0 Series Instruction Set		U10904J	-
78K/0 Series Instruction Table		U10903J	-
μPD78054Y Special Function Register Table		U10087J	-
78K/0 Series Application Note	Basics (III)	IEA-767	U10182E

Development Tool Related Documents (User's Manual)

Document Name		Document No. (Japanese)	Document No. (English)
RA78K Series Assembler Package	Operation	EEU-809	EEU-1399
	Language	EEU-815	EEU-1404
RA78K Series Structured Assembler Preprocessor		EEU-817	EEU-1402
CC78K Series C Compiler	Operation	EEU-656	EEU-1280
	Language	EEU-655	EEU-1284
CC78K/0 C Compiler Application Note	Programming Know-How	EEA-618	EEA-1208
CC78K Series Library Source File		EEU-777	-
PG-1500 PROM Programmer		EEU-651	EEU-1335
PG-1500 Controller PC-9800 Series (MS-DOS) Based		EEU-704	EEU-1291
PG-1500 Controller IBM PC Series (PC DOS) Based		EEU-5008	U10540E
IE-78000-R		EEU-810	EEU-1398
IE-78000-R-A		U10057J	U10057E
IE-78000-R-BK		EEU-867	EEU-1427
IE-78064-R-EM		EEU-905	EEU-1443
EP-78230		EEU-985	EEU-1515
SM78K0 System Simulator	Reference	EEU-5002	U10181E
SM78K Series System Simulator	External Part User Open Interface Specifications	U10092J	U10092E
SD78K/0 Screen Debugger PC-9800 Series (MS-DOS) Based	Introduction	EEU-852	-
	Reference	EEU-816	-
SD78K/0 Screen Debugger IBM PC/AT (PC DOS) Based	Introduction	EEU-5024	EEU-1414
	Reference	EEU-993	EEU-1413

Caution The above documents are subject to change without notice. For design purpose, etc., be sure to use the latest document.

Embedded Software Documents (User's Manual)

Document Name		Document No. (Japanese)	Document No. (English)
78K/0 Series Real Time OS	Basics	EEU-912	-
	Installation	EEU-911	-
	Technical	EEU-913	-
MX78K0: OS for 78K/0 Series	Basic	EEU-5010	-
Fuzzy Knowledge Data Creation Tools		EEU-829	EEU-1438
78K/0, 78K/II, 87AD Series Fuzzy Inference Development Support System Translator		EEU-862	EEU-1444
78K/0 Series Fuzzy Inference Development Support System Fuzzy Inference Module		EEU-858	EEU-1441
78K/0 Series Fuzzy Inference Development Support System Fuzzy Inference Debugger		EEU-921	EEU-1458

Other Documents

Document Name	Document No. (Japanese)	Document No. (English)
Semiconductor Device Package Manual	IEI-635	IEI-1213
Semiconductor Device Mounting Technology Manual	IEI-616	IEI-1207
Quality Grades on NEC Semiconductor Device	IEI-620	IEI-1209
NEC Semiconductor Device Reliability/Quality Control System	IEM-5068	IEI-1203
Electrostatic Discharge (ESD) Test	MEM-539	MEI-1201
Guide to Quality Assurance for Semiconductor Devices	MEI-603	MEI-1202
Microcomputer-related Product Guide, Third Party Products	MEI-604	-

Caution The above related documents are subject to change without notice. For design purpose, etc., be sure to use the latest documents.