

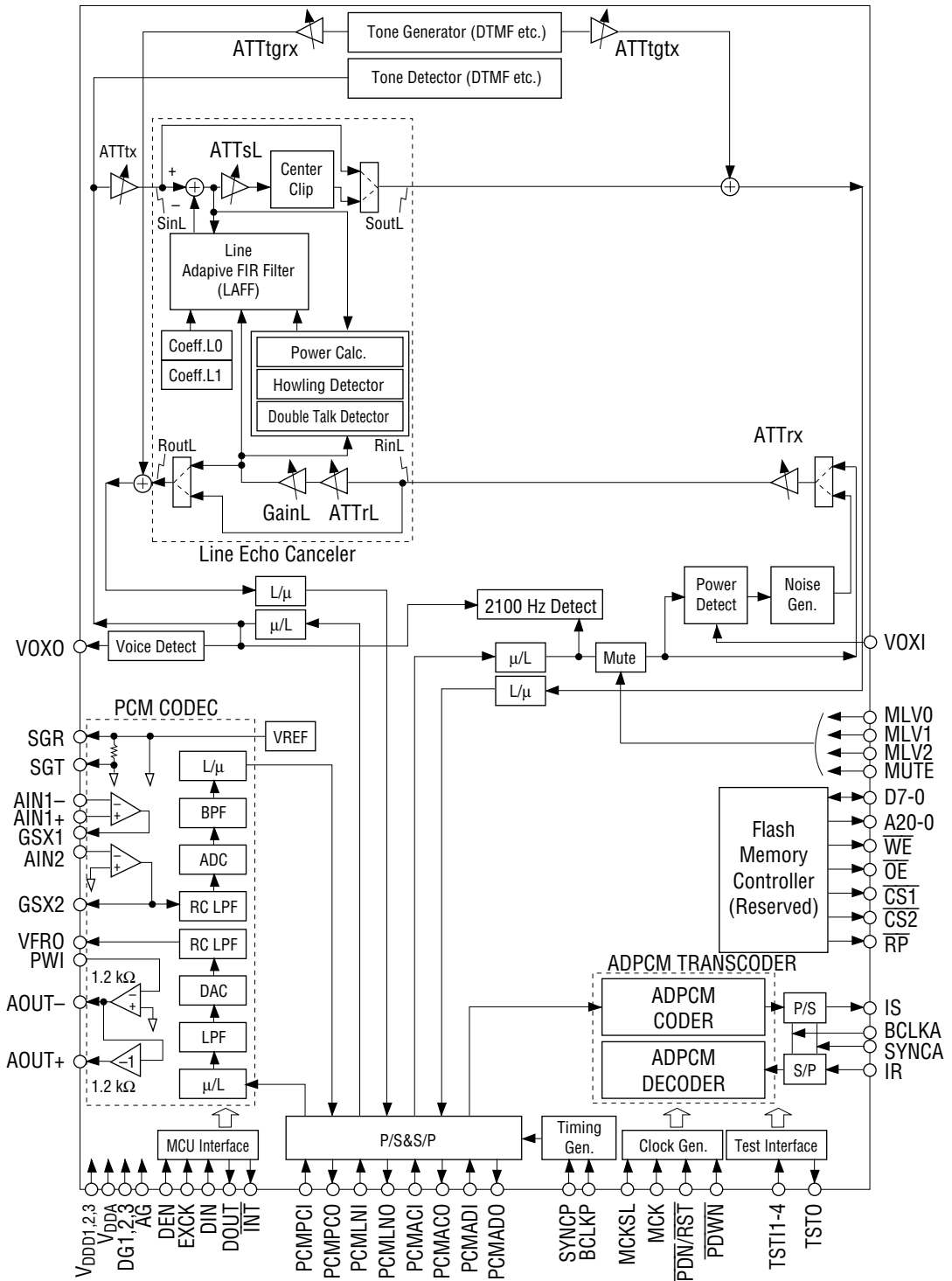
**MSM7718-01****Echo Canceler with ADPCM CODEC****GENERAL DESCRIPTION**

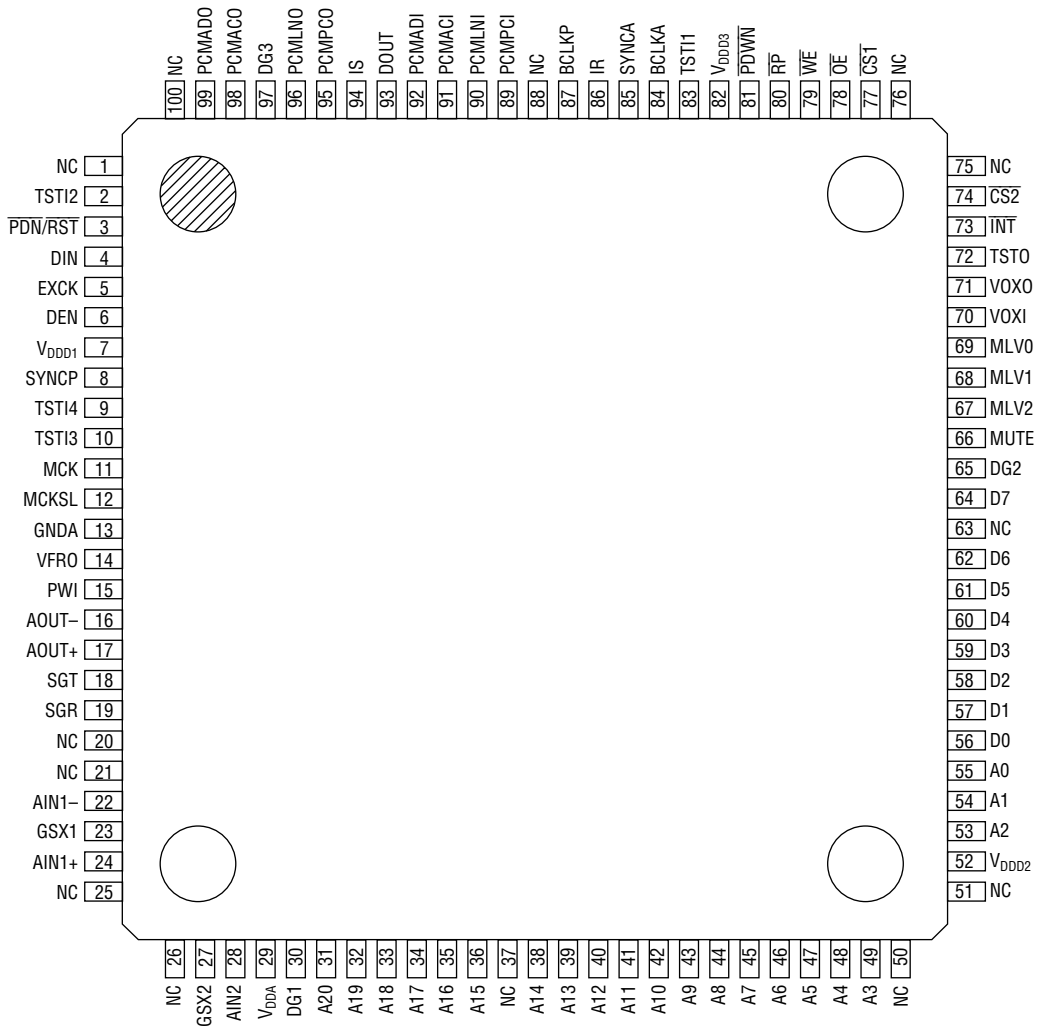
The MSM7718, developed for PHS (Personal Handyphone System) applications, is a CMOS LSI device and contains a line echo canceler and a single channel full-duplex ADPCM transcoder that performs interconversion between voice-band analog signal and 32 kbps ADPCM data. This device includes DTMF tone and several types of tone generation, transmit/receive data mute and gain control, and VOX function and is best suited for master telephones in PHS applications.

**FEATURES**

- Single 3 V power supply  $V_{DD}$  : 2.7 V to 3.6 V
- ADPCM : ITU-T Recommendations G.726 (32 kbps)
- Full-Duplex single channel operation
- Transmit/receive synchronous mode
- PCM interface coding format :  $\mu$ -law
- Built-in line echo canceler
  - Echo attenuation : 30 dB (typ.)
  - Cancelable echo delay time :
    - Normal speech mode : 23 ms (max.)
    - Line echo canceler expansion mode : 54 ms (max.)
- Serial PCM/ADPCM transmission data rate : 64 kbps to 2048 kbps
- Low power consumption
  - Operating mode : Typically 66 mW ( $V_{DD} = 3.0$  V)
  - Power-down mode : Typically 0.3 mW ( $V_{DD} = 3.0$  V)
- Two analog input gain adjustable amplifier stages
- Analog output stage : Push-pull drive, (direct drive of 350  $\Omega$  + 120 nF)
- Master clock frequency : 9.600/19.200 MHz
- Transmit/receive mute, transmit/receive programmable gain control
- Built-in DTMF tone generator and various ringing tones generator
- DTMF tone and call progress tone detection
- Serial MCU interface control
- Built-in VOX control
  - Transmit side : Voice/silence detect
  - Receive side : Background noise generation at the absence of voice signal
- Built-in 2100 Hz tone detection (bidirectional)
- Package:
  - 100-pin plastic TQFP (TQFP100-1414-0.50-K) (Product name : MSM7718-01TS-K)

**BLOCK DIAGRAM**





NC: No-connect pin

**100-Pin Plastic TQFP**

**PIN FUNCTIONAL DESCRIPTION**

**AIN1+, AIN1-, AIN2, GSX1, GSX2**

Transmit analog inputs and the outputs for transmit gain adjustment. AIN1- (AIN2) connects to inverting input of the internal transmit amplifier. AIN1+ connects to non-inverting input of the internal transmit amplifier. GSX1 (GSX2) connects to the internal transmit amplifier output. Refer to Fig.1 for gain adjustment.

**VFRO, AOUT+, AOUT-, PWI**

Receive analog outputs and the output for receive gain adjustment. VFRO is the receive filter output. AOUT+ and AOUT- are differential analog signal outputs which can directly drive  $Z_L (= 350 \Omega + 120 \text{ nF})$  or a 1.2 k $\Omega$  load. Refer to Fig.1 for gain adjustment. However, these outputs are in high impedance state during power-down.

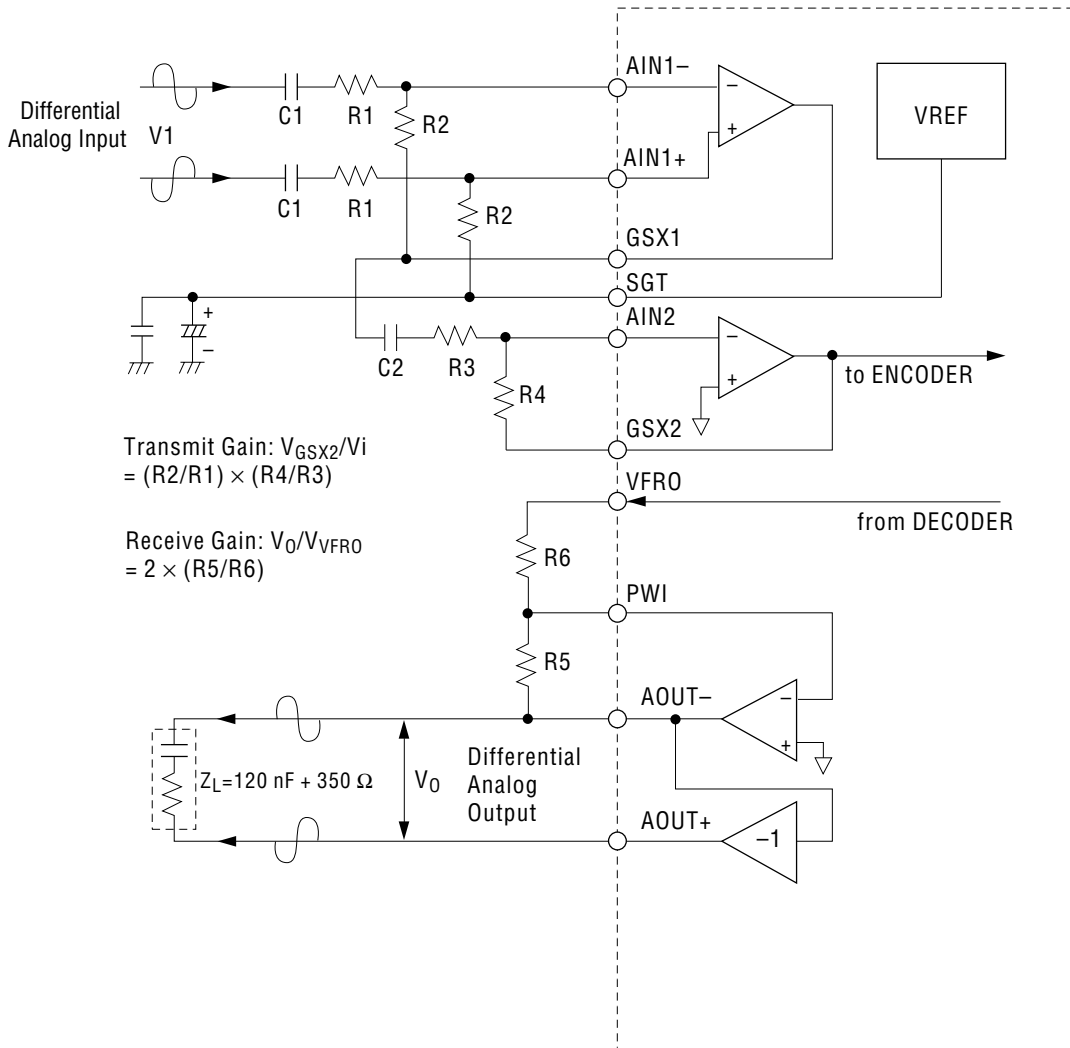


Figure 1 Analog Interface

**SGT, SGR**

Outputs of the analog signal ground voltage.

SGT outputs the analog signal ground voltage of the transmit system, and SGR outputs the analog signal ground voltage for the receive system. The output voltage is approximately 1.4 V. Connect bypass capacitors of 10  $\mu$ F and 0.1  $\mu$ F (ceramic type) between these pins and the AG pin. However to reduce the response time of the receiver power-on, it is recommended to apply bypass capacitors of 1  $\mu$ F and 0.1  $\mu$ F. During power-down, the output changes to 0 V.

**AG**

Analog ground.

**DG1, 2, 3**

Digital ground.

**V<sub>DDA</sub>**

+3 V power supply for analog circuits.

**V<sub>DDD1, 2, 3</sub>**

+3 V power supply for digital circuits.

 **$\overline{\text{PDN/RST}}$** 

Power-down reset control input.

A logic "0" makes the LSI device enter a power-down state. At the same time, all control register data is reset to the initial state. Set this pin to a logic "1" during normal operating mode. Since the  $\overline{\text{PDN/RST}}$  pin is ORed with CR0-B5 of the control register, set CR0-B5 to digital "0" when using this pin.

 **$\overline{\text{PDWN}}$** 

Power-down control input.

When set to a logic "0", the device changes to the power-down state, but each bit of control register and internal variables of control register are retained. During normal operation, set this pin to logic "1". Since the  $\overline{\text{PDWN}}$  pin is ORed with CR0-B6 of the control register, set CR0-B6 to logic "0" when using this pin.

**MCK**

Master clock input.

The frequency must be 9.6 MHz or 19.2 MHz. The master clock signal is allowed to be asynchronous with SYNCP, SYNCA, BCLKP, and BCLKA.

**MCKSL**

Master clock selection input.

Set MCKSL to logic "0" when the master clock frequency is 9.6 MHz, and to logic "1" when it is 19.2 MHz.

**PCMPCO**

PCM data output of the PCM CODEC.

PCM is output from MSB, synchronizing with the rising edge of BCLKP and SYNCN. This pin is in a high impedance state except during 8-bit PCM output. (It is also in a high impedance state during power-down mode.) A pull-up resistor must be connected to this pin because its output is configured as an open drain.

**PCMPCI**

PCM data input of the PCM CODEC.

PCM is shifted in at the falling edge of the BCLKP signal. The start of the PCM data (MSB) is identified at the rising edge of SYNCN.

**PCMADO**

PCM data output of the ADPCM transcoder.

PCM is the output data after ADPCM decoder processing and is serially output from MSB in synchronization with the rising edge of BCLKP and SYNCN. However, this signal timing can be controlled at PCM multiplexing by the control register CR1-B5.

(The time slot 1 or 2 can be selected. Refer to Figs. 2-4.)

This pin is in a high impedance state except during 8-bit PCM output. (It is also in a high impedance state during power-down mode.) A pull-up resistor must be connected to this pin because its output is configured as an open drain.

**PCMADI**

PCM data input of the ADPCM transcoder.

PCM is shifted in at a falling edge of the BCLKP signal and input from MSB. The start of the PCM data (MSB) is identified at the rising edge of SYNCN. However, this signal timing can be controlled at PCM multiplexing by the control register CR1-B5.

(The time slot 1 or 2 can be selected. Refer to Figs. 2-4.)

**PCMLNO**

PCM receive data output of the line echo canceler.

PCM is output from MSB in a sequential order, synchronizing with the rising edge of BCLKP and SYNCN. However, this signal timing can be controlled at PCM multiplexing by the control register CR2-B3 to B5.

(The time slot of 1 to 7 can be selected. Refer to Figs. 2-4.)

This pin is in a high impedance state except during 8-bit PCM output. (It is also in a high impedance state during power-down mode.) A pull-up resistor must be connected to this pin because its output is configured as an open drain.

**PCMLNI**

PCM transmit data input of the line echo canceler.

PCM is shifted in at a falling edge of the BCLKP signal and input from MSB. The start of the PCM data (MSB) is identified at the rising edge of SYNCNCP. However, this signal timing can be controlled at PCM multiplexing by the control register CR2-B3 to B5.

(One of the time slots 1 to 7 can be selected. Refer to Figs. 2-4.)

**PCMACO**

PCM transmit data output of the line echo canceler.

PCM is output from MSB in a sequential order, synchronizing with the rising edge of BCLKP and SYNCNCP. However, this signal timing can be controlled at PCM multiplexing by the control register CR2-B0 to B2. (The time slot 1 to 7 can be selected. Refer to Figs. 2 - 4.)

This pin is in a high impedance state except during 8-bit PCM output.

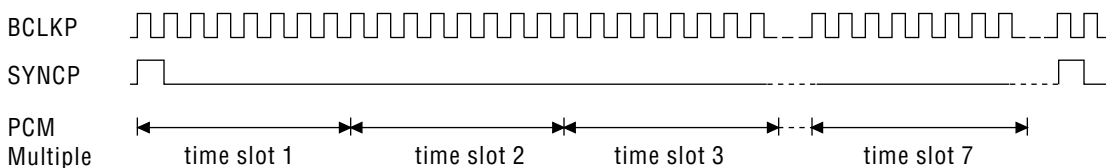
(It is also in a high impedance state during power down mode.) A pull-up resistor must be connected to this pin because its output is configured as an open drain.

**PCMACI**

PCM receive data input of the line echo canceler.

PCM is shifted in at a falling edge of BCLKP and input from MSB.

The start of the PCM data (MSB) is identified at the rising edge of SYNCNCP. However, this signal timing can be controlled at PCM multiplexing by the control register CR2-B0 to B2. (One of the time slots 1 to 7 can be selected. Refer to Figs. 2-4.)

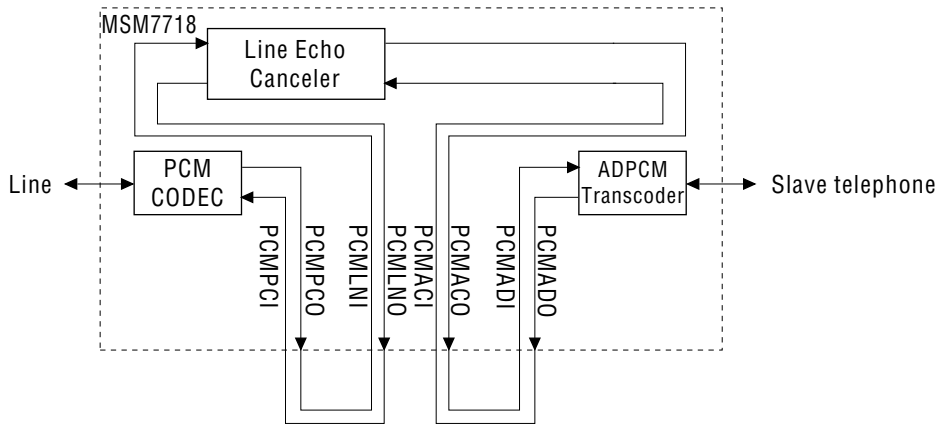


Note : The PCM signals (PCMPCI and PCMPKO) of the PCM CODEC are always assigned to time slot 1.

The PCM signals (PCMADI and PCMAKO) of the ADPCM transcoder can be assigned to time slot 1 or 2.

The PCM signals (PCMLNI, PCMLNO, PCMACI, PCMACO) of the line echo canceler can be assigned to one of the time slots 1 to 7. (Multiple timing is controlled by CR1 and CR2.)

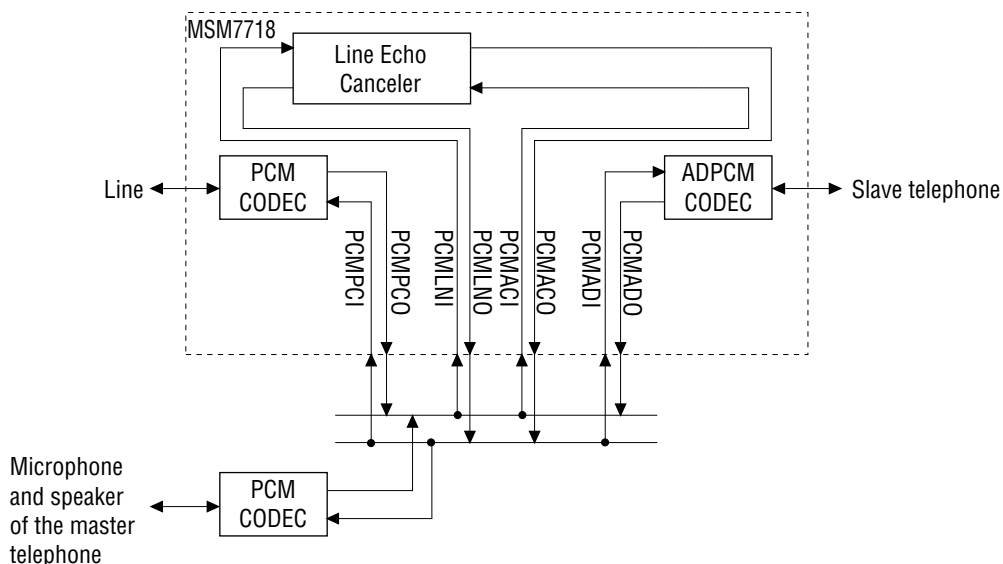
**Figure 2 PCM Multiple Timing**



Note : In this connection, PCMLNI, PCMLNO, PCMACI, and PCMACO should all be assigned to time slot 1 for their output timing (the output timing for the PCM CODEC is always assigned to time slot 1).  
 Turn on the line echo canceler and establish a route between the slave telephone and the line.

**Figure 3 PCM Signal Connection Example 1**





Notes : The PCM signals of the ADPCM transcoder are assigned to time slot 2. (The PCM signals of the PCM CODEC are always assigned to time slot 1.) The PCM signals of an external PCM CODEC are assigned to time slot 3.

Route between the line and the slave telephone

PCMLNI and PCMLNO are assigned to time slot 1 and PCMACI and PCMACO are assigned to time slot 2.

Turn on the line echo canceler, and establish the route between the line and the slave telephone.

Route between the master telephone's microphone/ speaker (handsfree) and the slave telephone

PCMLNI and PCMLNO are assigned to time slot 3 and PCMACI and PCMACO are assigned to time slot 2.

Turn on the line echo canceler, and establish the route between the microphone/ speaker of the master telephone and the slave telephone.

Route between the line and the master telephone's microphone/ speaker (handsfree)

PCMLNI and PCMLNO are assigned to time slot 1 and PCMACI and PCMACO are assigned to time slot 3.

Put the line echo canceler into "through mode", and establish the route between the line and the microphone/ speaker of the master telephone.

Various routing can be implemented providing extension of external PCM CODECs.

**Figure 4 PCM Signal Connection Example 2**

**BCLKP**

Shift clock input for the PCM data (PCMPCO, PCMPCL, PCMADO, PCMADI, PCMLNO, PCMLNI, PCMACO, PCMACI). The frequency is set in the range of 64 kHz to 2048 kHz. This signal must be synchronized with the SYNCP signal. (Refer to Fig. 2.)

**SYNCP**

8 kHz synchronous signal input for transmit and receive PCM data. This signal must be synchronized with the BCLKP signal. (Refer to Fig. 2.)

**IS**

Transmit ADPCM data output.

This data is the output data after ADPCM encoding, and is serially output from MSB in synchronization with the rising edge of BCLKA and SYNCA. This pin is an open drain output which remains in a high impedance state during power-down, and requires a pull-up resistor.

**IR**

Receive ADPCM data input.

ADPCM is shifted in on the rising edge of BCLKA in synchronization with SYNCA and input orderly from MSB.

**BCLKA**

Shift clock input for the ADPCM data (IS, IR). The frequency is from 64 kHz to 2048 kHz. This signal must be synchronized with the SYNCA signal.

**SYNCA**

8 kHz synchronous signal input for transmit and receive ADPCM data. Synchronize this data with BCLKA signal. SYNCA is used for indicating the MSB of the serial ADPCM data stream.

**DEN, EXCK, DIN, DOUT,  $\overline{\text{INT}}$** 

Serial control ports for MCU interface.

Reading and writing data is performed by an external MCU through these pins. 17-byte control registers are provided in this device.

DEN is the "Enable" control signal input, EXCK is the data shift clock input, DIN is the address and data input, and DOUT is the data output.

Input/output timing is shown in Fig. 5.

$\overline{\text{INT}}$  goes to logic "0" when any change has been found in the tone detection results in the tone detection mode (change in the control register bits CR7-B3, B2), and goes to logic "1" when the data of control register CR7 is read out.

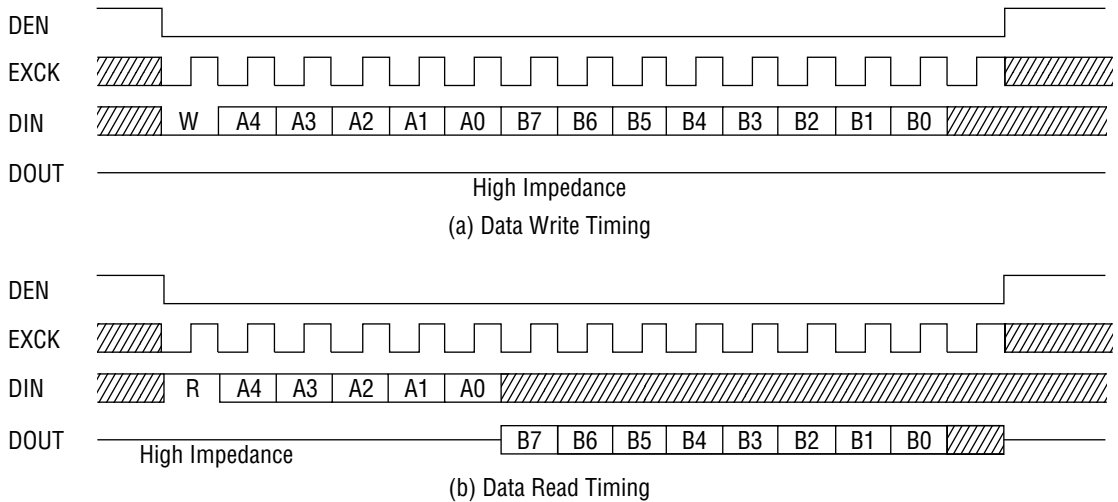


Figure 5 MCU Interface Input/Output Timing

**VOXO**

Signal output for transmit VOX function.

The VOX function recognizes the presence or absence of the transmit voice signal by detecting the level of the transmit signal to the line echo canceler. "1" and "0" levels set to this pin correspond to the presence and the absence of voice, respectively. This result appears also at the register data CR7-B7. The signal energy detect threshold is set by the control register data CR6-B6, B5.

The timing diagram of the VOX function is shown in Fig 6.

The transmit signal to the line echo canceler refers to the signal input to the PCMLNI pin.

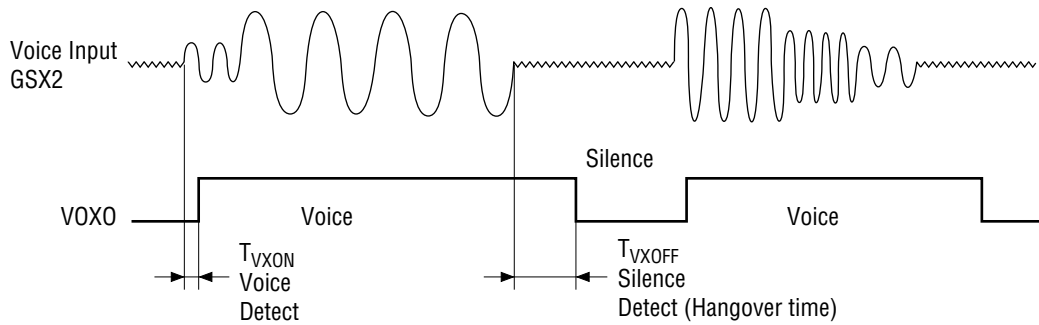
**VOXI**

Signal input for receive VOX function.

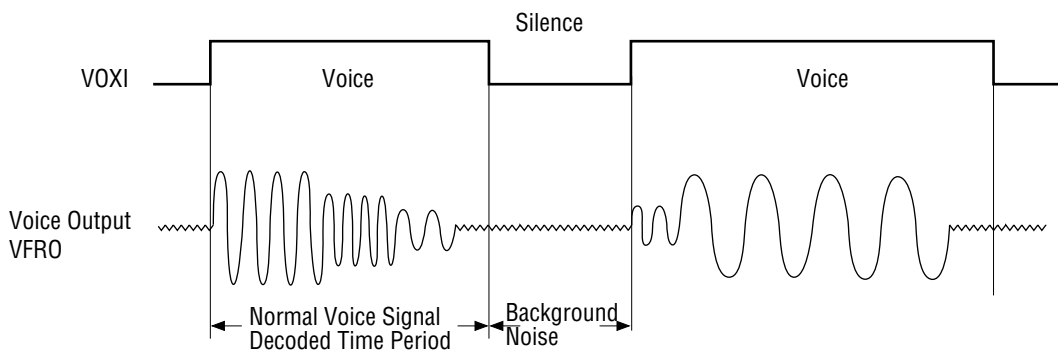
The "1" level at VOXI indicates the presence of a voice signal, the decoder block processes normal receive signal, and the voice signal on the PCMACI pin goes through. The "0" level indicates the absence of a voice signal and the background noise generated in this device is output to the line echo canceler.

The background noise amplitude is set by the control register CR6.

Because this signal is ORed with the register data CR6-B3, set the control register data CR6-B3 to logic "0".



(a) Transmit VOX Function Timing Diagram (for Analog Input)



(b) Receive VOX Function (CR6-B3: logic "0") Timing Diagram (for Analog Input)

Note: The VOX function is valid when CR6-B7 is set to logic "1".

### Figure 6 VOX Function

#### MUTE

This pin is used to enable the receive side voice path mute level. To set the mute level, set this pin to "1".

#### MLV0, MLV1, MLV2

These pins are used to set the receive side voice path mute level. For the control method, refer to the control register description (CR1). Since these pins are ORed with CR1-B2, B1, and B0 internally, set the bits of the register to "0" before using this pin.

**D7 to D0 (reserved for external memory I/F)**

Output of write data, and input-output of read data.

**A20 to A0 (reserved for external memory I/F)**

External memory address output.

 **$\overline{\text{WE}}$  (reserved for external memory I/F)**

Output for write control .

 **$\overline{\text{OE}}$  (reserved for external memory I/F)**

Output for read control.

 **$\overline{\text{CS1}}$ ,  $\overline{\text{CS2}}$  (reserved for external memory I/F)**

Chip select output.

 **$\overline{\text{RP}}$  (reserved for external memory I/F)**

Reset/power-down control output for external memory.

**TSTI1, TSTI2, TSTI3, TSTI4**

Input for test.

Normally fix these pins to logic "0".

**TSTI4**

Input for mode select.

Fix this pin to logic "0" for normal speech mode.

Fix this pin to logic "1" for line echo canceler expansion mode. Refer to the explanation of CR0 for the operation mode.

**TSTO**

Output for test.

**ABSOLUTE MAXIMUM RATINGS**

| Parameter             | Symbol    | Condition | Rating                 | Unit |
|-----------------------|-----------|-----------|------------------------|------|
| Power Supply Voltage  | $V_{DD}$  | —         | -0.3 to +5             | V    |
| Analog Input Voltage  | $V_{AIN}$ | —         | -0.3 to $V_{DD} + 0.3$ | V    |
| Digital Input Voltage | $V_{DIN}$ | —         | -0.3 to $V_{DD} + 0.3$ | V    |
| Storage Temperature   | $T_{STG}$ | —         | -55 to +150            | °C   |

**RECOMMENDED OPERATING CONDITIONS** $(V_{DD} = 2.7 \text{ V to } 3.6 \text{ V}, T_a = -25^\circ\text{C to } +70^\circ\text{C})$ 

| Parameter                        | Symbol     | Condition                         | Min.                    | Typ.     | Max.                    | Unit          |
|----------------------------------|------------|-----------------------------------|-------------------------|----------|-------------------------|---------------|
| Power Supply Voltage             | $V_{DD}$   | —                                 | 2.7                     | —        | 3.6                     | V             |
| Operating Temperature            | $T_a$      | —                                 | -25                     | +25      | +70                     | °C            |
| Input High Voltage               | $V_{IH}$   | All digital inputs                | 0.45<br>$\times V_{DD}$ | —        | —                       | V             |
| Input Low Voltage                | $V_{IL}$   | All digital inputs                | 0                       | —        | 0.16<br>$\times V_{DD}$ | V             |
| Digital Input Rise Time          | $t_{ir}$   | All digital inputs                | —                       | —        | 50                      | ns            |
| Digital Input Fall Time          | $t_{if}$   | All digital inputs                | —                       | —        | 50                      | ns            |
| Master Clock Frequency           | $f_{MCK}$  | MCK                               | -100ppm                 | 19.2/9.6 | +100ppm                 | MHz           |
| Master Clock Duty Ratio          | $D_C$      | MCK                               | 40                      | 50       | 60                      | %             |
| Bit Clock Frequency              | $f_{BCK}$  | BCLKP, BCLKA                      | 64                      | —        | 2048                    | kHz           |
| Synchronous Pulse Frequency      | $f_{SYNC}$ | SYNCP, SYNCA                      | -1000ppm                | 8.0      | +1000ppm                | kHz           |
| Clock Duty Cycle                 | $D_{CK}$   | BCLKP, BCLKA, EXCK                | 40                      | 50       | 60                      | %             |
| Transmit Sync Pulse Setting Time | $t_{XS}$   | BCLKP to SYNCP,<br>BCLKA to SYNCA | 100                     | —        | —                       | ns            |
|                                  | $t_{SX}$   | SYNCP to BCLKP,<br>SYNCA to BCLKA | 100                     | —        | —                       | ns            |
|                                  | $t_{XO}$   | SYNCP to BCLKP, SYNCA to BCLKA    | —                       | —        | 100                     | ns            |
| Receive Sync Pulse Setting Time  | $t_{RS}$   | BCLKP to SYNCP,<br>BCLKA to SYNCA | 100                     | —        | —                       | ns            |
|                                  | $t_{SR}$   | SYNCP to BCLKP,<br>SYNCA to BCLKA | 100                     | —        | —                       | ns            |
|                                  | $t_{RO}$   | SYNCP to BCLKP, SYNCA to BCLKA    | —                       | —        | 100                     | ns            |
| Receive Sync Pulse Setting Time  | $t_{WS}$   | SYNCP, SYNCA                      | 1 BCLK                  | —        | 100                     | $\mu\text{s}$ |
| PCM, ADPCM Setup Time            | $t_{DS}$   | —                                 | 100                     | —        | —                       | ns            |
| PCM, ADPCM Hold Time             | $t_{DH}$   | —                                 | 100                     | —        | —                       | ns            |

Note: If SYNCP and SYNCA are generated from different clocks, do not change the relative timing of the rising edge of SYNCP and that of SYNCA (that is, which rising edge is earlier) after the reset state has been released.

## ELECTRICAL CHARACTERISTICS

### DC Characteristics

(V<sub>DD</sub>= 2.7 to 3.6 V, T<sub>a</sub>= -25 to +70°C)

| Parameter                         | Symbol           | Condition   | Min.                | Typ. | Max.            | Unit |
|-----------------------------------|------------------|---|---------------------|------|-----------------|------|
| Power Supply Current 1            | I <sub>DD1</sub> | Operating mode, no signal<br>(only the master clock is input) | —                   | 22   | 40              | mA   |
| Power Supply Current 2            | I <sub>DD2</sub> | Power down mode<br>(only the master clock is input)           | —                   | 0.2  | 1               | mA   |
| Input Leakage current             | I <sub>IH</sub>  | V <sub>I</sub> =V <sub>DD</sub>                               | —                   | —    | 2               | μA   |
|                                   | I <sub>IL</sub>  | V <sub>I</sub> = 0 V  | —                   | —    | 0.5             | μA   |
| High Level Digital Output Voltage | V <sub>OH1</sub> | I <sub>OH</sub> = 0.4 mA                                      | 0.5×V <sub>DD</sub> | —    | V <sub>DD</sub> | V    |
|                                   | V <sub>OH2</sub> | I <sub>OH</sub> = 1 μA  | 0.8×V <sub>DD</sub> | —    | V <sub>DD</sub> | V    |
| Low Level Digital Output Voltage  | V <sub>OL</sub>  | 1LSTTL, pull-up resistance : 500 Ω                            | 0                   | 0.2  | 0.4             | V    |
| Digital Output Leakage Current    | I <sub>O</sub>   | IS  | —                   | —    | 10              | μA   |
| Input Capacitance                 | C <sub>IN</sub>  | —   | —                   | 5    | —               | pF   |

### Analog Interface Characteristics

(V<sub>DD</sub>= 2.7 to 3.6 V, T<sub>a</sub>= -25 to +70°C)

| Parameter                 | Symbol             | Condition                                  | Min. | Typ | Max. | Unit            |
|---------------------------|--------------------|--|------|-----|------|-----------------|
| Input Resistance          | R <sub>IN</sub>    | AIN+, AIN-, AIN2, PWI                      | 10   | —   | —    | MΩ              |
| Output Load Resistance    | R <sub>L1</sub>    | GSX1, GSX2, VFRO                           | 20   | —   | —    | kΩ              |
|                           | R <sub>L2</sub>    | AOUT+                                      | 1.2  | —   | —    | kΩ              |
|                           | R <sub>L3</sub>    | AOUT-                                      | 1.2  | —   | —    | kΩ              |
| Output Load Capacitance   | C <sub>L1</sub>    | GSX1, GSX2, VFRO                           | —    | —   | 100  | pF              |
|                           | C <sub>L2</sub>    | AOUT+                                      | —    | —   | 100  | pF              |
|                           | C <sub>L3</sub>    | AOUT-                                      | —    | —   | 100  | pF              |
| Output Voltage Level (*1) | V <sub>O1</sub>    | GSX1, GSX2, VFRO<br>(R <sub>L</sub> =20kΩ) | —    | —   | 1.3  | V <sub>PP</sub> |
|                           | V <sub>O2</sub>    | AOUT+ (R <sub>L</sub> =1.2 kΩ)             | —    | —   | 1.3  | V <sub>PP</sub> |
|                           | V <sub>O3</sub>    | AOUT- (R <sub>L</sub> =1.2 kΩ)             | —    | —   | 1.3  | V <sub>PP</sub> |
| Offset Voltage            | V <sub>OFFGX</sub> | VFRO                                       | -100 | —   | +100 | mV              |
|                           | V <sub>OFFGX</sub> | VFRO                                       | -20  | —   | +20  | mV              |
| SGT, SGR Output Voltage   | V <sub>SG</sub>    | SGT, SGR                                   | —    | 1.4 | —    | V               |
| SGT Output Impedance      | R <sub>SGT</sub>   | SGT  | —    | 40  | 80   | kΩ              |
| SGR Output Impedance      | R <sub>SGR</sub>   | SGR  | —    | 4   | 8    | kΩ              |

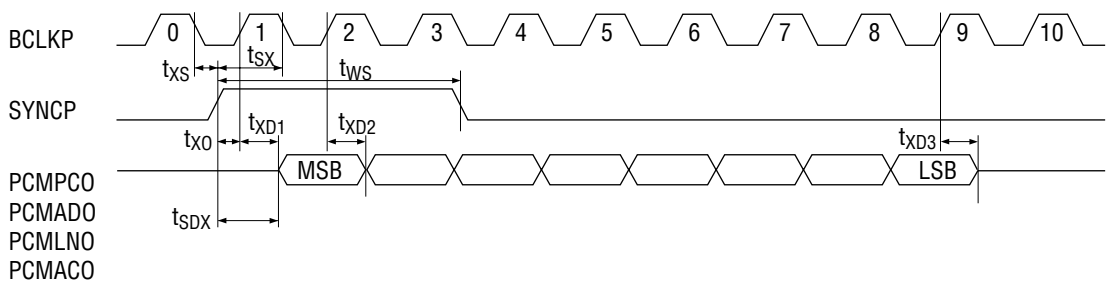
\*1 -7.7 dBm (600 Ω) = 0 dBm<sub>0</sub>, +3.14 dBm<sub>0</sub>=1.30 V<sub>PP</sub>

Digital Interface Characteristics

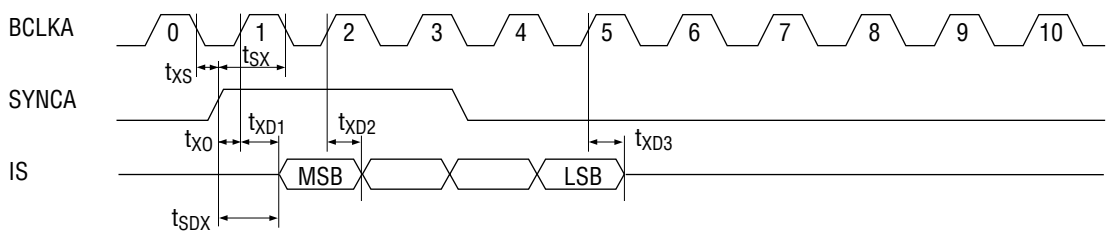
(V<sub>DD</sub>= 2.7 to 3.6 V, T<sub>a</sub>= -25 to +70°C)

| Parameter   | Symbol                              | Condition   | Min. | Typ. | Max.      | Unit |
|---|-------------------------------------|---|------|------|-----------|------|
| Digital Output Delay Time<br>PCM, ADPCM Interface   | t <sub>SDX</sub> , t <sub>SDR</sub> | 1LSTTL+100 pF                                     | 0    | —    | 200 (100) | ns   |
|   | t <sub>XD1</sub> , t <sub>RD1</sub> | pull-up resistance : 500 Ω                        | 0    | —    | 200 (100) | ns   |
|   | t <sub>XD2</sub> , t <sub>RD2</sub> | Values in parentheses apply when<br>Clod = 10 pF, | 0    | —    | 200 (100) | ns   |
|   | t <sub>XD3</sub> , t <sub>RD3</sub> | pull-up resistance : ≤2 kΩ                        | 0    | —    | 200 (100) | ns   |
| Serial Port<br>Digital Input/Output<br>Setting Time | t <sub>M1</sub>                     | Clod=100 pF                                       | 50   | —    | —         | ns   |
|   | t <sub>M2</sub>                     |   | 20   | —    | —         | ns   |
|   | t <sub>M3</sub>                     |   | 20   | —    | —         | ns   |
|   | t <sub>M4</sub>                     |   | 50   | —    | —         | ns   |
|   | t <sub>M5</sub>                     |   | 100  | —    | —         | ns   |
|   | t <sub>M6</sub>                     |   | 50   | —    | —         | ns   |
|   | t <sub>M7</sub>                     |   | 50   | —    | —         | ns   |
|   | t <sub>M8</sub>                     |   | 0    | —    | —         | ns   |
|   | t <sub>M9</sub>                     |   | 50   | —    | —         | ns   |
|   | t <sub>M10</sub>                    |   | 50   | —    | —         | ns   |
|   | t <sub>M11</sub>                    |   | 0    | —    | —         | ns   |
|   | t <sub>M12</sub>                    |   | 100  | —    | —         | ns   |
| Shift Clock Frequency                               | f <sub>ECK</sub>                    | EXCK  | —    | —    | 10        | MHz  |

PCM/ADPCM Output Timing

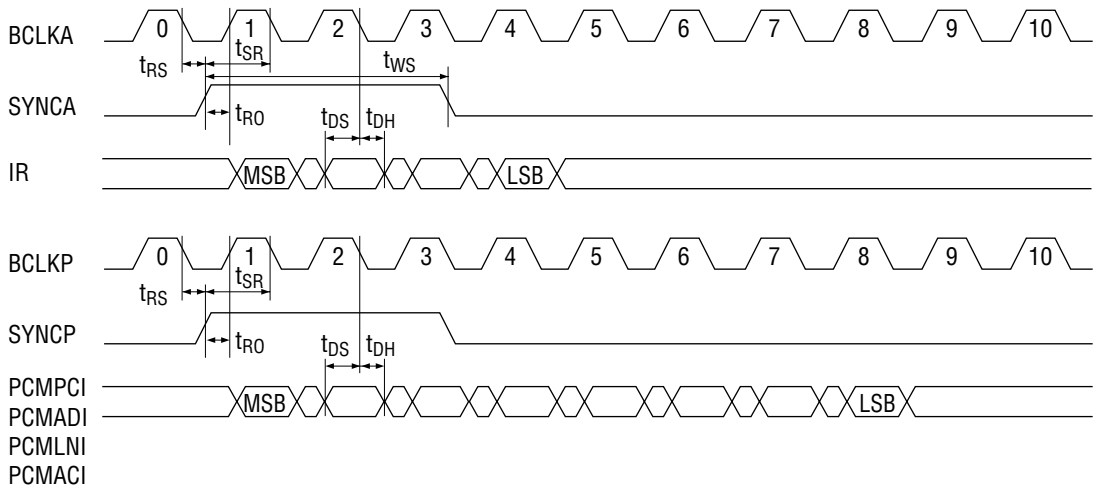


Note : The timing for PCMADO, PCMLNO, and PCMACO shown above represents the timing when time slot 1 is selected.



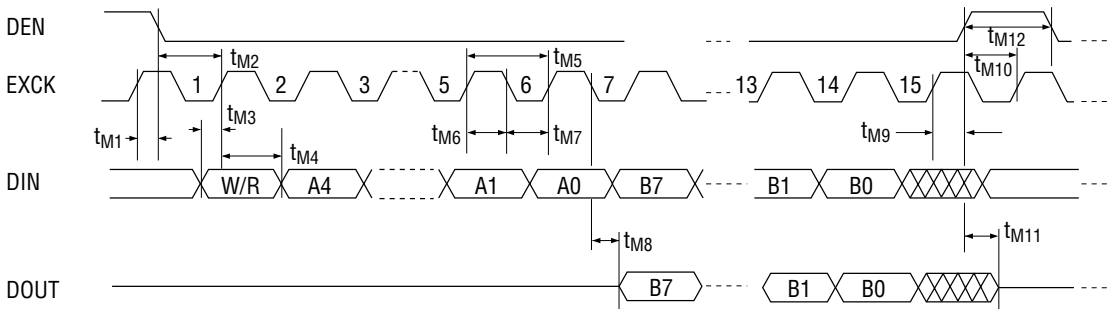


**PCM/ADPCM Input Timing**



Note : The timing for PCMADI, PCMLNI, and PCMACI shown above represents the timing when time slot 1 is selected.

**Serial Port Timing for Microcontroller Interface**



AC Characteristics

(V<sub>DD</sub> = 2.7 to 3.6 V, T<sub>a</sub> = -25 to +70°C)

| Parameter                          | Symbol              | Condition    |                     |        | Min.      | Typ.     | Max.           | Unit             |
|------------------------------------|---------------------|--------------|---------------------|--------|-----------|----------|----------------|------------------|
|                                    |                     | Freq.(Hz)    | level (dBm0)        | Others |           |          |                |                  |
| Transmit Frequency Response        | L <sub>oss</sub> T1 | 0-60         | 0                   | —      | 25        | —        | —              | dB               |
|                                    | L <sub>oss</sub> T2 | 300-3k       |                     |        | -0.15     | —        | +0.2           |                  |
|                                    | L <sub>oss</sub> T3 | 1020         |                     |        | Reference |          |                |                  |
|                                    | L <sub>oss</sub> T4 | 3300         |                     |        | -0.15     | —        | +0.8           |                  |
|                                    | L <sub>oss</sub> T5 | 3400         |                     |        | 0         | —        | 0.8            |                  |
|                                    | L <sub>oss</sub> T6 | 3968.75      |                     |        | 13        | —        | —              |                  |
| Receive Frequency Response         | L <sub>oss</sub> R1 | 0-3000       | 0                   | —      | -0.15     | —        | +0.2           | dB               |
|                                    | L <sub>oss</sub> R2 | 1020         |                     |        | Reference |          |                |                  |
|                                    | L <sub>oss</sub> R3 | 3300         |                     |        | -0.15     | —        | +0.8           |                  |
|                                    | L <sub>oss</sub> R4 | 3400         |                     |        | 0         | —        | 0.8            |                  |
|                                    | L <sub>oss</sub> R5 | 3968.75      |                     |        | 13        | —        | —              |                  |
| Transmit Signal to Distortion      | SD T1               | 1020         | 3                   | (*2)   | 35        | —        | —              | dB               |
|                                    | SD T2               |              | 0                   |        | 35        | —        | —              |                  |
|                                    | SD T3               |              | -30                 |        | 35        | —        | —              |                  |
|                                    | SD T4               |              | -40                 |        | 28        | —        | —              |                  |
|                                    | SD T5               |              | -45                 |        | 23        | —        | —              |                  |
| Receive Signal to Distortion       | SD R1               | 1020         | 3                   | (*2)   | 35        | —        | —              | dB               |
|                                    | SD R2               |              | 0                   |        | 35        | —        | —              |                  |
|                                    | SD R3               |              | -30                 |        | 35        | —        | —              |                  |
|                                    | SD R4               |              | -40                 |        | 28        | —        | —              |                  |
|                                    | SD R5               |              | -45                 |        | 23        | —        | —              |                  |
| Transmit Gain Tracking             | GT T1               | 1020         | 3                   | —      | -0.2      | —        | +0.2           | dB               |
|                                    | GT T2               |              | -10                 |        | Reference |          |                |                  |
|                                    | GT T3               |              | -40                 |        | -0.2      | —        | +0.2           |                  |
|                                    | GT T4               |              | -50                 |        | -0.5      | —        | +0.5           |                  |
|                                    | GT T5               |              | -55                 |        | -1.2      | —        | +1.2           |                  |
| Receive Gain Tracking              | GT R1               | 1020         | 3                   | —      | -0.2      | —        | +0.2           | dB               |
|                                    | GT R2               |              | -10                 |        | Reference |          |                |                  |
|                                    | GT R3               |              | -40                 |        | -0.2      | —        | +0.2           |                  |
|                                    | GT R4               |              | -50                 |        | -0.5      | —        | +0.5           |                  |
|                                    | GT R5               |              | -55                 |        | -1.2      | —        | +1.2           |                  |
| Idle Channel Noise                 | N <sub>IDLT</sub>   | —            | A <sub>IN</sub> =SG | (*2)   | —         | —        | -68<br>(-75.7) | dBm0p<br>(dBmp)  |
|                                    | N <sub>IDLR</sub>   | —            | (*3)                | (*2)   | —         | —        | -72<br>(79.7)  | dBm0p<br>(dBmp)  |
| Absolute Signal Amplitude          | A <sub>VT</sub>     | 1020         | 0                   | GSX2   | 0.285     | 0.32(*4) | 0.359          | V <sub>rms</sub> |
|                                    | A <sub>VR</sub>     |              |                     | VFRO   | 0.285     | 0.32(*4) | 0.359          | V <sub>rms</sub> |
| Power Supply Noise Rejection Ratio | P <sub>SRRT</sub>   | Noise Freq.: | Noise Level:        | —      | 30        | —        | —              | dB               |
|                                    | P <sub>SRRR</sub>   | 0 to 50 kHz  | 50 mVpp             |        | 30        | —        | —              | dB               |

- \*2. P-message weighted filter used
- \*3. PCMPIC input code: "11111111" (μ-law)
- \*4. 0.320 V<sub>rms</sub>=0 dBm0=-7.7 dBm

Note : All ADPCM coder and decoder characteristics fully comply with ITU-T Recommendations G.726.

**AC Characteristics (DTMF and Other Tones)**

(V<sub>DD</sub> = 2.7 to 3.6 V, T<sub>a</sub> = -25 to +70°C)

| Parameter                        | Symbol            | Condition   |                           | Min. | Typ. | Max. | Unit |
|----------------------------------|-------------------|---|---------------------------|------|------|------|------|
| Frequency Deviation              | Df <sub>T1</sub>  | DTMF Tones  |                           | -1.5 | —    | +1.5 | %    |
|                                  | Df <sub>T2</sub>  | Other various tones   |                           | -1.5 | —    | +1.5 | %    |
| Tone Reference Output Level (*5) | V <sub>TL</sub>   | Transmit side tone  | DTMF (Low group)          | -10  | -8   | -6   | dBm0 |
|                                  | V <sub>TH</sub>   | (Gain set value:0dB)  | DTMF (High group), Others | -8   | -6   | -4   | dBm0 |
|                                  | V <sub>RL</sub>   | Receive side tone   | DTMF (Low group)          | -10  | -8   | -6   | dBm0 |
|                                  | V <sub>RH</sub>   | (Gain set value:0dB)  | DTMF (High group), Others | -8   | -6   | -4   | dBm0 |
| Relative Value of DTMF Tones     | R <sub>DTMF</sub> | V <sub>TH</sub> /V <sub>TL</sub> , V <sub>RH</sub> /V <sub>RL</sub> |                           | 1    | 2    | 3    | dB   |

\*5 Not including programmable gain set values

**AC Characteristics (Gain Settings)**

(V<sub>DD</sub> = 2.7 to 3.6 V, T<sub>a</sub> = -25 to +70°C)

| Parameter                              | Symbol         | Condition               | Min. | Typ. | Max. | Unit |
|--|----------------|-------------------------|------|------|------|------|
| Transmit/Receive Gain Setting Accuracy | D <sub>G</sub> | For all gain set values | -1   | 0    | +1   | dB   |

**AC Characteristics (VOX Function)**

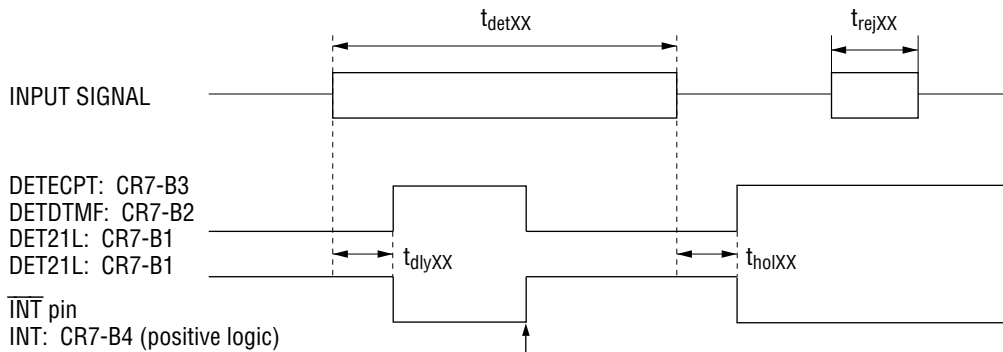
(V<sub>DD</sub> = 2.7 to 3.6 V, T<sub>a</sub> = -25 to +70°C)

| Parameter  | Symbol             | Condition                                    |   | Min.    | Typ.    | Max.    | Unit |
|--|--------------------|--|---|---------|---------|---------|------|
| Transmit VOX Detection Time<br>voice signal ON/OFF Detect Time | t <sub>VXON</sub>  | Silence→voice                                | VOXO pin:see Fig.6<br>Voice/silence<br>differential:10 dB | —       | 5       | —       | ms   |
|  | t <sub>VXOFF</sub> | Voice→silence                                |   | 140/300 | 160/320 | 180/340 | ms   |
| Transmit VOX Detection Level Accuracy (Voice Detection Level)  | D <sub>VX</sub>    | For detection level set values by CRM6-B6,B5 |   | -2.5    | 0       | +2.5    | dB   |

**AC Characteristics (Tone Detect Function)**

( $V_{DD} = 2.7$  to  $3.6$  V,  $T_a = -25$  to  $+70^\circ\text{C}$ )

| Parameter                           | Symbol      | Condition                                      | Min.      | Typ. | Max.      | Unit |
|-------------------------------------|-------------|--|-----------|------|-----------|------|
| CPT Detection Frequency             | $f_{detcp}$ | —  | 350       | —    | 640       | Hz   |
| CPT Non-detection Frequency         | $f_{rejcp}$ | —  | 700       | —    | —         | Hz   |
|                                     |             |  | —         | —    | 250       | Hz   |
| CPT Detection Level                 | $V_{detcp}$ | Input Frequency: 350 to 640 Hz                 | -39       | —    | 0         | dBm0 |
| CPT Non-detection Level             | $V_{rejcp}$ | —  | —         | —    | -49       | dBm0 |
| CPT Input Signal Continuation Time  | $t_{detcp}$ | CPT detected                                   | 55        | —    | —         | ms   |
|                                     | $t_{rejcp}$ | CPT not detected                               | —         | —    | 30        | ms   |
| CPT Detection Delay Time            | $t_{dlycp}$ | —  | 30        | 45   | 55        | ms   |
| CPT Detection Hold Time             | $t_{holcp}$ | —  | 7         | 16   | 24        | ms   |
| DTMF Detection Frequency            | $f_{detdt}$ | At Nominal Frequency                           | —         | —    | $\pm 1.5$ | %    |
| DTMF Non-detection Frequency        | $f_{rejdt}$ | At Nominal Frequency                           | $\pm 3.8$ | —    | —         | %    |
| DTMF Detection Level                | $V_{detdt}$ | Input Frequency: Nominal Frequency $\pm 1.5\%$ | -39       | —    | 0         | dBm0 |
| DTMF Non-detection Level            | $V_{rejdt}$ | —  | —         | —    | -47       | dBm0 |
| DTMF Input Signal continuation Time | $t_{detdt}$ | CPT detected                                   | 38        | —    | —         | ms   |
|                                     | $t_{rejdt}$ | CPT not detected                               | —         | —    | 16        | ms   |
| DTMF Detection Delay Time           | $t_{dlydt}$ | —  | 16        | —    | 38        | ms   |
| DTMF Detection Hold Time            | $t_{holdt}$ | —  | 14        | —    | 25        | ms   |
| ANS Detection Frequency             | $f_{detan}$ | —  | 2079      | 2100 | 2121      | Hz   |
| ANS Non-detection Frequency         | $f_{rejan}$ | —  | 2350      | —    | —         | Hz   |
|                                     |             |  | —         | —    | 1900      | Hz   |
| ANS Detection Level                 | $V_{detan}$ | Input Frequency: 2079 to 2121 Hz               | -31       | —    | 0         | dBm0 |
| ANS Non-detection Level             | $V_{rejan}$ | —  | —         | —    | -35       | dBm0 |
| ANS Input Signal Continuation Time  | $t_{detan}$ | CPT detected                                   | 480       | —    | —         | ms   |
|                                     | $t_{rejan}$ | CPT not detected                               | —         | —    | 420       | ms   |
| ANS Detection Delay Time            | $t_{dlyan}$ | —  | 420       | 450  | 480       | ms   |
| ANS Detection Hold Time             | $t_{holan}$ | —  | 7         | 12   | 17        | ms   |



The state of the  $\overline{\text{INT}}$  pin is changed by reading the contents of CR7. It is retained when CR7 is not read.

Note : In the case of call progress tone, DTMF tone, and 2100 Hz tone, XX refers to cp, dt, and an respectively.

**FUNCTIONAL DESCRIPTION**

**Control Registers**

**Table 1 Control Register Map**

| Reg Name | Address |    |    |    |    | Contents        |                 |                 |               |                |                     |                |                | R/W |
|----------|---------|----|----|----|----|-----------------|-----------------|-----------------|---------------|----------------|---------------------|----------------|----------------|-----|
|          | A4      | A3 | A2 | A1 | A0 | B7              | B6              | B5              | B4            | B3             | B2                  | B1             | B0             |     |
| CR0      | 0       | 0  | 0  | 0  | 0  | —               | PDWN            | PDN/RST         | —             | OPE MODE3      | OPE MODE2           | OPE MODE1      | OPE MODE0      | R/W |
| CR1      | 0       | 0  | 0  | 0  | 1  | ADPCM MODE      | ADPCM RESET     | PCM AD SEL      | TX MUTE       | RX MUTE        | RX MLV2             | RX MLV1        | RX MLV0        | R/W |
| CR2      | 0       | 0  | 0  | 1  | 0  | PCM PCO MUTE    | PCM PCI MUTE    | PCM LN SEL2     | PCM LN SEL1   | PCM LN SEL0    | PCM AC SEL2         | PCM AC SEL1    | PCM AC SEL0    | R/W |
| CR3      | 0       | 0  | 0  | 1  | 1  | TX GAIN3        | TX GAIN2        | TX GAIN1        | TX GAIN0      | RX GAIN3       | RX GAIN2            | RX GAIN1       | RX GAIN0       | R/W |
| CR4      | 0       | 0  | 1  | 0  | 0  | TX TONE GAIN3   | TX TONE GAIN2   | TX TONE GAIN1   | TX TONE GAIN0 | RX TONE GAIN3  | RX TONE GAIN2       | RX TONE GAIN1  | RX TONE GAIN0  | R/W |
| CR5      | 0       | 0  | 1  | 0  | 1  | DTMF/OTHERS SEL | TX TONE SEND    | RX TONE SEND    | TONE4         | TONE3          | TONE2               | TONE1          | TONE0          | R/W |
| CR6      | 0       | 0  | 1  | 1  | 0  | VOX ON/OFF      | ON LVL1         | ON LVL0         | OFF TIME      | VOX IN         | RX. NOISE LEVEL SEL | RX. NOISE LVL1 | RX. NOISE LVL0 | R/W |
| CR7      | 0       | 0  | 1  | 1  | 1  | VOX OUT         | Silence level 1 | Silence level 0 | INT           | DET CPT        | DET DTMF            | BUSY/DET21L    | RPM/DET21A     | R   |
| CR8      | 0       | 1  | 0  | 0  | 0  | LECTHR (HCL)*   | LECCLR1         | LECCLR2         | LECHD         | LECCCLP (NLP)* | LECHLD (ADP)*       | LECATT (ATT)*  | LECGC (GC)*    | R/W |
| CR9      | 0       | 1  | 0  | 0  | 1  | AECTHR (HCL)*   | —               | AECCLR          | AECHD         | AECCLP (NLP)*  | AECHLD (APD)*       | AECATT (ATT)*  | AECGC (GC)*    | R/W |
| CR10     | 0       | 1  | 0  | 1  | 0  | SEND/REC        | MEM SEL         | ADPCM MODE1     | ADPCM MODE0   | CMD3           | CMD2                | CMD1           | CMD0           | R/W |
| CR11     | 0       | 1  | 0  | 1  | 1  | ST7/A7          | ST6/A6          | ST5/A5          | ST4/A4        | ST3/A3         | ST2/A2              | ST1/A1         | ST0/A0         | R/W |
| CR12     | 0       | 1  | 1  | 0  | 0  | ST15/A15        | ST14/A14        | ST13/A13        | ST12/A12      | ST11/A11       | ST10/A10            | ST9/A9         | ST8/A8         | R/W |
| CR13     | 0       | 1  | 1  | 0  | 1  | —               | —               | —               | ST20/A20      | ST19/A19       | ST18/A18            | ST17/A17       | ST16/A16       | R/W |
| CR14     | 0       | 1  | 1  | 1  | 0  | SP7             | SP6             | SP5             | SP4           | SP3            | SP2                 | SP1            | SP0            | R/W |
| CR15     | 0       | 1  | 1  | 1  | 1  | SP15            | SP14            | SP13            | SP12          | SP11           | SP10                | SP9            | SP8            | R/W |
| CR16     | 1       | 0  | 0  | 0  | 0  | —               | —               | —               | SP20          | SP19           | SP18                | SP17           | SP16           | R/W |
| CR17     | 1       | 0  | 0  | 0  | 1  | D7/CA7          | D6/CA6          | D5/CA5          | D4/CA4        | D3/CA3         | D2/CA2              | D1/CA1         | D0/CA0         | R/W |
| CR18     | 1       | 0  | 0  | 1  | 0  | WA7             | WA6             | WA5             | WA4           | D TONE3/WA3    | D TONE2/WA2         | D TONE1/WA1    | D TONE0/WA0    | R/W |

R/W : Read/write enable R : Read only register

\* : These are the symbols of control pins used in the MSM7602 (echo canceler LSI device).



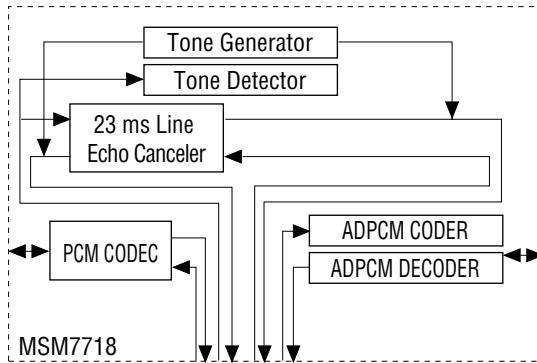


Figure 7-1 Normal Speech Mode

Note :

- When the MSM7718 is used in normal speech mode, set the TSTI4 pin to "0".
- In normal speech mode, the tone detector can detect call progress tone and DTMF tone by PMLNI input.

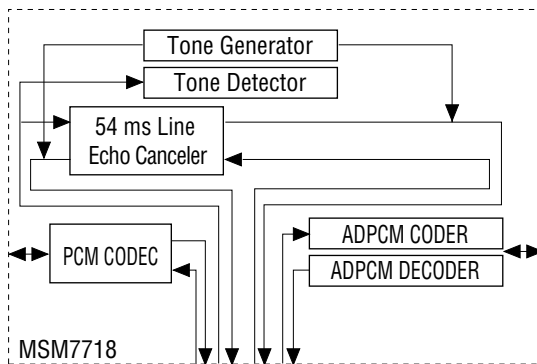


Figure 7-2 Line Echo Canceled Expansion Mode

Note :

- When the MSM7718 is used in line echo canceled expansion mode, set the TSTI4 pin to digital "1".
- In line echo canceled expansion mode, the tone detector can detect not only call progress tone and DTMF tone by PMLNI input but also 2100 Hz tone by PCMLNI and PCMACI input (bidirectional).
- The PCM CODEC does not operate in this mode. A capacitor is required between SGT and ground and between SGR and ground (see Application Circuit).





(3)CR2 (Setting of PCM I/O multiple control)

|               | <b>B7</b>    | <b>B6</b>    | <b>B5</b>   | <b>B4</b>   | <b>B3</b>   | <b>B2</b>   | <b>B1</b>   | <b>B0</b>   |
|---------------|--------------|--------------|-------------|-------------|-------------|-------------|-------------|-------------|
| CR2           | PCM PCO MUTE | PCM PCI MUTE | PCM LN SEL2 | PCM LN SEL1 | PCM LN SEL0 | PCM AC SEL2 | PCM AC SEL1 | PCM AC SEL0 |
| Initial value | 0            | 0            | 0           | 0           | 0           | 0           | 0           | 0           |

B7 ... ON or OFF of the PCM signal of the transmitter side of the PCM CODEC (PCMPCO pin)  
 0: ON 1: OFF

When this bit is "1" (OFF), the PCMPCO pin transmits a PCM idle pattern.

B6 ... ON or OFF of the PCM signal of the receiver side of the PCM CODEC (PCMPCI pin)  
 0: ON 1: OFF

When this bit is "1" (OFF), the PCMPCI pin receives a PCM idle pattern.

B5, 4, 3.... PCMI/O multiple timing control (PCMLNI and PCMLNO pins) of the line echo canceler  
 (see Table 2)

B2, 1, 0.... PCMI/O multiple timing control (PCMACI and PCMACO pins) of the line echo canceler  
 (see Table 2)

**Table 2 PCM Multiple Timing Control Table**

| <b>B5<br/>(B2)</b> | <b>B4<br/>(B1)</b> | <b>B3<br/>(B0)</b> | <b>Corresponding time slot</b> |
|--------------------|--------------------|--------------------|--------------------------------|
| 0                  | 0                  | 0                  | None                           |
| 0                  | 0                  | 1                  | 1                              |
| 0                  | 1                  | 0                  | 2                              |
| 0                  | 1                  | 1                  | 3                              |
| 1                  | 0                  | 0                  | 4                              |
| 1                  | 0                  | 1                  | 5                              |
| 1                  | 1                  | 0                  | 6                              |
| 1                  | 1                  | 1                  | 7                              |

Note : When bits B5 to B3 or B2 to B0 are all zeros, the internal process inputs a PCM idle pattern.  
 In this case, the outputs are all in high impedance state for all time slots.

(4)CR3 (Transmit/receive gain adjustment)

|               | <b>B7</b>   | <b>B6</b>   | <b>B5</b>   | <b>B4</b>   | <b>B3</b>   | <b>B2</b>   | <b>B1</b>   | <b>B0</b>   |
|---------------|-------------|-------------|-------------|-------------|-------------|-------------|-------------|-------------|
| CR3           | TX<br>GAIN3 | TX<br>GAIN2 | TX<br>GAIN1 | TX<br>GAIN0 | RX<br>GAIN3 | RX<br>GAIN2 | RX<br>GAIN1 | RX<br>GAIN0 |
| Initial value | 0           | 0           | 0           | 0           | 0           | 0           | 0           | 0           |

B7, 6, 5, 4 ..... Adjustment of the transmit signal gain [ATTtx]  
(see Table 3)

B3, 2, 1, 0 ..... Adjustment of the receive signal gain [ATTrx]  
(see Table 3)

**Table 3 Transmit/Receive Signal Gain Setting**

| <b>B7</b> | <b>B6</b> | <b>B5</b> | <b>B4</b> | <b>Transmit signal gain</b> | <b>B3</b> | <b>B2</b> | <b>B1</b> | <b>B0</b> | <b>Receive signal gain</b> |
|-----------|-----------|-----------|-----------|-----------------------------|-----------|-----------|-----------|-----------|----------------------------|
| 1         | 0         | 0         | 0         | -16 dB                      | 1         | 0         | 0         | 0         | -16 dB                     |
| 1         | 0         | 0         | 1         | -14 dB                      | 1         | 0         | 0         | 1         | -14 dB                     |
| 1         | 0         | 1         | 0         | -12 dB                      | 1         | 0         | 1         | 0         | -12 dB                     |
| 1         | 0         | 1         | 1         | -10 dB                      | 1         | 0         | 1         | 1         | -10 dB                     |
| 1         | 1         | 0         | 0         | -8 dB                       | 1         | 1         | 0         | 0         | -8 dB                      |
| 1         | 1         | 0         | 1         | -6 dB                       | 1         | 1         | 0         | 1         | -6 dB                      |
| 1         | 1         | 1         | 0         | -4 dB                       | 1         | 1         | 1         | 0         | -4 dB                      |
| 1         | 1         | 1         | 1         | -2 dB                       | 1         | 1         | 1         | 1         | -2 dB                      |
| 0         | 0         | 0         | 0         | 0 dB                        | 0         | 0         | 0         | 0         | 0 dB                       |
| 0         | 0         | 0         | 1         | +2 dB                       | 0         | 0         | 0         | 1         | +2 dB                      |
| 0         | 0         | 1         | 0         | +4 dB                       | 0         | 0         | 1         | 0         | +4 dB                      |
| 0         | 0         | 1         | 1         | +6 dB                       | 0         | 0         | 1         | 1         | +6 dB                      |
| 0         | 1         | 0         | 0         | +8 dB                       | 0         | 1         | 0         | 0         | +8 dB                      |
| 0         | 1         | 0         | 1         | +10 dB                      | 0         | 1         | 0         | 1         | +10 dB                     |
| 0         | 1         | 1         | 0         | +12 dB                      | 0         | 1         | 1         | 0         | +12 dB                     |
| 0         | 1         | 1         | 1         | +14 dB                      | 0         | 1         | 1         | 1         | +14 dB                     |

This table is for gains of transmit/receive voice signals.

(5)CR4 (Adjustment of tone generator gain)

|               | B7               | B6               | B5               | B4               | B3               | B2               | B1               | B0               |
|---------------|------------------|------------------|------------------|------------------|------------------|------------------|------------------|------------------|
| CR4           | TX TONE<br>GAIN3 | TX TONE<br>GAIN2 | TX TONE<br>GAIN1 | TX TONE<br>GAIN0 | RX TONE<br>GAIN3 | RX TONE<br>GAIN2 | RX TONE<br>GAIN1 | RX TONE<br>GAIN0 |
| Initial value | 0                | 0                | 0                | 0                | 0                | 0                | 0                | 0                |

B7, 6, 5, 4 ..... Transmit side gain adjustment for the tone generator [ATTtgrx] (see Table 4)  
 B3, 2, 1, 0 ..... Receive side gain adjustment for the tone generator [ATTtgrx] (see Table 5)

**Table 4 Setting of Transmit Side Gain of Tone Generator**

| B7 | B6 | B5 | B4 | Tone generator gain | B7 | B6 | B5 | B4 | Tone generator gain |
|----|----|----|----|---------------------|----|----|----|----|---------------------|
| 0  | 0  | 0  | 0  | -36 dB              | 1  | 0  | 0  | 0  | -20 dB              |
| 0  | 0  | 0  | 1  | -34 dB              | 1  | 0  | 0  | 1  | -18 dB              |
| 0  | 0  | 1  | 0  | -32 dB              | 1  | 0  | 1  | 0  | -16 dB              |
| 0  | 0  | 1  | 1  | -30 dB              | 1  | 0  | 1  | 1  | -14 dB              |
| 0  | 1  | 0  | 0  | -28 dB              | 1  | 1  | 0  | 0  | -12 dB              |
| 0  | 1  | 0  | 1  | -26 dB              | 1  | 1  | 0  | 1  | -10 dB              |
| 0  | 1  | 1  | 0  | -24 dB              | 1  | 1  | 1  | 0  | -8 dB               |
| 0  | 1  | 1  | 1  | -22 dB              | 1  | 1  | 1  | 1  | -6 dB               |

**Table 5 Setting of Receive Side Gain of Tone Generator**

| B3 | B2 | B1 | B0 | Tone generator gain | B3 | B2 | B1 | B0 | Tone generator gain |
|----|----|----|----|---------------------|----|----|----|----|---------------------|
| 0  | 0  | 0  | 0  | -36 dB              | 1  | 0  | 0  | 0  | -20 dB              |
| 0  | 0  | 0  | 1  | -34 dB              | 1  | 0  | 0  | 1  | -18 dB              |
| 0  | 0  | 1  | 0  | -32 dB              | 1  | 0  | 1  | 0  | -16 dB              |
| 0  | 0  | 1  | 1  | -30 dB              | 1  | 0  | 1  | 1  | -14 dB              |
| 0  | 1  | 0  | 0  | -28 dB              | 1  | 1  | 0  | 0  | -12 dB              |
| 0  | 1  | 0  | 1  | -26 dB              | 1  | 1  | 0  | 1  | -10 dB              |
| 0  | 1  | 1  | 0  | -24 dB              | 1  | 1  | 1  | 0  | -8 dB               |
| 0  | 1  | 1  | 1  | -22 dB              | 1  | 1  | 1  | 1  | -6 dB               |

Settings of Table 5 are made in relation to the following tone levels:

DTMF tone (Low frequency group) : -2 dBm0

DTMF tone (High frequency group) and other tone : 0 dBm0

For example, when bits B3, B2, B1, and B0 are set to "1, 1, 1, 1" (-6 dB), the PCMLNO pin outputs a tone of the following levels:

DTMF tone (Low frequency group) : -8 dBm0

DTMF tone (High frequency group) and other tone : -6 dBm0

The default value change command enables the gain adjustment by -1 dB step.

Writing "13CAh" into the address 00D8h adds a gain of -1 dB to the values in the above table. The default value is "1634h".

(6)CR5 (Setting of tone generator operating mode and tone frequency)

|               | <b>B7</b>          | <b>B6</b>       | <b>B5</b>       | <b>B4</b> | <b>B3</b> | <b>B2</b> | <b>B1</b> | <b>B0</b> |
|---------------|--------------------|-----------------|-----------------|-----------|-----------|-----------|-----------|-----------|
| CR5           | DTMF/OTHERS<br>SEL | TX TONE<br>SEND | RX TONE<br>SEND | TONE4     | TONE3     | TONE2     | TONE1     | TONE0     |
| Initial value | 0                  | 0               | 0               | 0         | 0         | 0         | 0         | 0         |

B7 ... Selection of DTMF signal or others (S, F, or R tone)

0: Others 1: DTMF signal

B6... Transmission of transmit side tone 0: Not transmit 1: Transmit

B5... Transmission of receive side tone 0: Not transmit 1: Transmit

B4, 3, 2, 1, 0 ... Setting of a tone frequency (see Table 6)

**Table 6 Setting of Tone Generator Frequencies**

(a) when B7 = "1" (DTMF tone)

| <b>B4</b> | <b>B3</b> | <b>B2</b> | <b>B1</b> | <b>B0</b> | <b>Description</b>   | <b>B4</b> | <b>B3</b> | <b>B2</b> | <b>B1</b> | <b>B0</b> | <b>Description</b>   |
|-----------|-----------|-----------|-----------|-----------|----------------------|-----------|-----------|-----------|-----------|-----------|----------------------|
| *         | 0         | 0         | 0         | 0         | 697 Hz + 1209 Hz (1) | *         | 1         | 0         | 0         | 0         | 852 Hz + 1209 Hz (7) |
| *         | 0         | 0         | 0         | 1         | 697 Hz + 1336 Hz (2) | *         | 1         | 0         | 0         | 1         | 852 Hz + 1336 Hz (8) |
| *         | 0         | 0         | 1         | 0         | 697 Hz + 1477 Hz (3) | *         | 1         | 0         | 1         | 0         | 852 Hz + 1477 Hz (9) |
| *         | 0         | 0         | 1         | 1         | 697 Hz + 1633 Hz (A) | *         | 1         | 0         | 1         | 1         | 852 Hz + 1633 Hz (C) |
| *         | 0         | 1         | 0         | 0         | 770 Hz + 1209 Hz (4) | *         | 1         | 1         | 0         | 0         | 941 Hz + 1209 Hz (*) |
| *         | 0         | 1         | 0         | 1         | 770 Hz + 1336 Hz (5) | *         | 1         | 1         | 0         | 1         | 941 Hz + 1336 Hz (0) |
| *         | 0         | 1         | 1         | 0         | 770 Hz + 1477 Hz (6) | *         | 1         | 1         | 1         | 0         | 941 Hz + 1477 Hz (#) |
| *         | 0         | 1         | 1         | 1         | 770 Hz + 1633 Hz (B) | *         | 1         | 1         | 1         | 1         | 941 Hz + 1633 Hz (D) |

(b) When B7 = "0" (Others)

The Table below lists default frequencies. "00000" to "00011" ("B4, B3, B2, B1, B0") are tones, which are modulated by sinewave. "01000" to "01011" are wamble tones, and "10000" to "10111" are single tones. For procedures to change frequencies, see the next page.

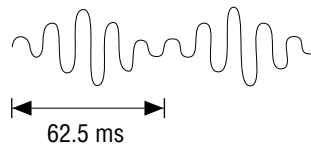
| <b>B4</b> | <b>B3</b> | <b>B2</b> | <b>B1</b> | <b>B0</b> | <b>Description</b>                   | <b>B4</b> | <b>B3</b> | <b>B2</b> | <b>B1</b> | <b>B0</b> | <b>Description</b>  |
|-----------|-----------|-----------|-----------|-----------|--------------------------------------|-----------|-----------|-----------|-----------|-----------|---------------------|
| 0         | 0         | 0         | 0         | 0         | 400/0H - 16 Hz Sine wave modulation  | 1         | 0         | 0         | 0         | 0         | 400 Hz Single tone  |
| 0         | 0         | 0         | 0         | 0         | 3000/0H - 16 Hz Sine wave modulation | 1         | 0         | 0         | 0         | 1         | 1000 Hz Single tone |
| 0         | 0         | 0         | 1         | 0         | 2700/0H - 16 Hz Sine wave modulation | 1         | 0         | 0         | 0         | 1         | 2000 Hz Single tone |
| 0         | 0         | 0         | 1         | 1         | */*H - 16 Hz Sine wave modulation    | 1         | 0         | 0         | 1         | 1         | 2667 Hz Single tone |
| 0         | 0         | 1         | 0         | 0         | —                                    | 1         | 0         | 1         | 0         | 0         | 1300 Hz Single tone |
| 0         | 0         | 1         | 0         | 1         | —                                    | 1         | 0         | 1         | 0         | 1         | 2080 Hz Single tone |
| 0         | 0         | 1         | 1         | 0         | —                                    | 1         | 0         | 1         | 1         | 0         | *Hz Single tone     |
| 0         | 0         | 1         | 1         | 1         | —                                    | 1         | 0         | 1         | 1         | 1         | *Hz Single tone     |
| 0         | 1         | 0         | 0         | 0         | 513/636 Hz 12 Hz Wamble              | 1         | 1         | 0         | 0         | 0         | —                   |
| 0         | 1         | 0         | 0         | 1         | 800/1000 Hz 8 Hz Wamble              | 1         | 1         | 0         | 0         | 1         | —                   |
| 0         | 1         | 0         | 1         | 0         | 2000/2667 Hz 8 Hz Wamble             | 1         | 1         | 0         | 1         | 0         | —                   |
| 0         | 1         | 0         | 1         | 1         | */*Hz *Hz Wamble                     | 1         | 1         | 0         | 1         | 1         | —                   |
| 0         | 1         | 1         | 0         | 0         | —                                    | 1         | 1         | 1         | 0         | 0         | —                   |
| 0         | 1         | 1         | 0         | 1         | —                                    | 1         | 1         | 1         | 0         | 1         | —                   |
| 0         | 1         | 1         | 1         | 0         | —                                    | 1         | 1         | 1         | 1         | 0         | —                   |
| 0         | 1         | 1         | 1         | 1         | —                                    | 1         | 1         | 1         | 1         | 1         | —                   |

Frequencies of tones (other than DTMF signals) to be generated by the tone generator can be changed. Tone frequencies can be changed in the Initial mode. See Figure 15-1 for procedures to change tone frequencies. The related subaddresses are shown below.

Modulation by 16 Hz sine wave

| B4 | B3 | B2 | B1 | B0 | Subaddress 1<br>(Frequency 1)<br>*1 |
|----|----|----|----|----|-------------------------------------|
| 0  | 0  | 0  | 0  | 0  | 164h                                |
| 0  | 0  | 0  | 0  | 1  | 165h                                |
| 0  | 0  | 0  | 1  | 0  | 166h                                |
| 0  | 0  | 0  | 1  | 1  | 167h                                |

Modulation by 16 Hz sine wave



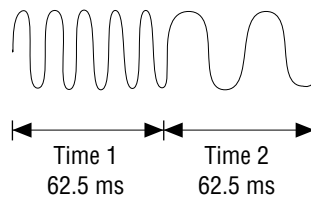
Wamble

| B4 | B3 | B2 | B1 | B0 | Subaddress 1<br>(Frequency 1)<br>*1 | Subaddress 2<br>(Frequency 2)<br>*1 | Subaddress 3<br>(Time 1)<br>*2 | Subaddress 4<br>(Time 2)<br>*2 |
|----|----|----|----|----|-------------------------------------|-------------------------------------|--------------------------------|--------------------------------|
| 0  | 1  | 0  | 0  | 0  | 168h                                | 16Ch                                | 170h                           | 174h                           |
| 0  | 1  | 0  | 0  | 1  | 169h                                | 16Dh                                | 171h                           | 175h                           |
| 0  | 1  | 0  | 1  | 0  | 16Ah                                | 16Eh                                | 172h                           | 176h                           |
| 0  | 1  | 0  | 1  | 1  | 16Bh                                | 16Fh                                | 173h                           | 177h                           |

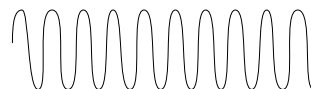
Single tone

| B4 | B3 | B2 | B1 | B0 | Subaddress 1<br>(Frequency 1)<br>*1 |
|----|----|----|----|----|-------------------------------------|
| 1  | 0  | 0  | 0  | 0  | 178h                                |
| 1  | 0  | 0  | 0  | 1  | 179h                                |
| 1  | 0  | 0  | 1  | 0  | 17Ah                                |
| 1  | 0  | 0  | 1  | 1  | 17Bh                                |
| 1  | 0  | 1  | 0  | 0  | 17Ch                                |
| 1  | 0  | 1  | 0  | 1  | 17Dh                                |
| 1  | 0  | 1  | 1  | 0  | 17Eh                                |
| 1  | 0  | 1  | 1  | 1  | 17Fh                                |

8 Hz wamble tone



Transmit single tone



\*1 Transmitted Tone Frequency = A × 8.192 (A = frequency)

ex. When frequency = 1000 Hz, 1000 × 8.192 = 9011.2 = 9011d (eliminate after the decimal point) = 2333h

\*2 Wamble Frequency (Tone Transmit time) = (A/B)/2 - 1  
(A = Transmitted tone frequency, B = wamble frequency)

ex. When wamble frequency is 8 Hz, tone frequency = 2667 Hz.  
(2667/8)/2 - 1 = 166.69 = 166d (eliminate after the decimal point) = A6h

(7)CR6 (VOX function control)

|               | <b>B7</b>     | <b>B6</b>  | <b>B5</b>  | <b>B4</b>   | <b>B3</b> | <b>B2</b>              | <b>B1</b>         | <b>B0</b>         |
|---------------|---------------|------------|------------|-------------|-----------|------------------------|-------------------|-------------------|
| CR6           | VOX<br>ON/OFF | ON<br>LVL1 | ON<br>LVLO | OFF<br>TIME | VOX<br>IN | RX. NOISE<br>LEVEL SEL | RX. NOISE<br>LVL1 | RX. NOISE<br>LVLO |
| Initial value | 0             | 0          | 0          | 0           | 0         | 0                      | 0                 | 0                 |

B7 ... Turns ON or OFF the VOX function. 0: OFF, 1: ON

B6, 5 ... Setting of transmit side voice or silence detection level

(0, 0) : -20 dBm0

(0, 1) : -25 dBm0

(1, 0) : -30 dBm0

(1, 1) : -35 dBm0

Note: • The detection level is changeable by inserting the pad of -1 dB to -5 dB in addition to the above values.

• Write  $16384 \times 10^{-A/20}$  at address "175h". (A=pad)

Example: When -1 dB pad is inserted,  $16384 \times 10^{-(-1)/20}$

=18383.15=18383d (eliminate after the decimal point)=47CFh

B4 ... Setting of hangover time (T<sub>VXOFF</sub>) (see Figure 6)

0: 160 ms 1: 320 ms

B3 ... VOX input signal (receiver side)

0: Transmits an internal background noise.

1: Transmits a voice reception signal.

Set the VOXI pin to "0" to use this data.

B2 ... Setting of a receiver side background noise level

0: Automatic internal setting

1: Reserved

B1, 0 ... Externally-set background noise level

(0, 0) : No noise

(0, 1) : -55 dBm0

(1, 0) : -45 dBm0

(1, 1) : -35 dBm0

(8)CR7 (Detection register : read-only)

|               | <b>B7</b>  | <b>B6</b>          | <b>B5</b>          | <b>B4</b> | <b>B3</b>  | <b>B2</b>   | <b>B1</b>       | <b>B0</b>      |
|---------------|------------|--------------------|--------------------|-----------|------------|-------------|-----------------|----------------|
| CR7           | VOX<br>OUT | Silence level<br>1 | Silence level<br>0 | INT       | DET<br>CPT | DET<br>DTMF | BUSY/<br>DET21L | PRM/<br>DET21A |
| Initial value | 0          | 0                  | 0                  | 0         | 0          | 0           | 0               | 0              |

B7 ... Detection of transmit side voice or noise

0: Silence 1: Voice

B6, 5 ... Transmit side silence level (indicator)

(0, 0) : -10 dB or less with respect to the detection level defined by CR6-B6, B5.

(0, 1) : -5 to -10 dB with respect to the detection level defined by CR6-B6, B5.

(1, 0) : 0 to -5 dB with respect to the detection level defined by CR6-B6, B5.

(1, 1) : 0 dB or more. Refer to the detection level defined by CR6-B6, B5.

Note : The above outputs are valid only when the VOX function is enabled by bit 7 of CR6.

B4 ... External interrupt signal

Goes to a logic "0" when any change has been found in the tone detection results for call progress tone, DTMF tone, and 2100 Hz tone.

Goes to a logic "1" when the CR7 control register is read out .

The inverted state of this bit (B4) is output to the  $\overline{\text{INT}}$  pin.



(10) CR9 : Reserved (Setting of acoustic echo canceler operating mode)

|               | <b>B7</b>         | <b>B6</b> | <b>B5</b> | <b>B4</b> | <b>B3</b>         | <b>B2</b>         | <b>B1</b>         | <b>B0</b>       |
|---------------|-------------------|-----------|-----------|-----------|-------------------|-------------------|-------------------|-----------------|
| CR9           | AECTHR<br>(HCL)*1 | —         | AECCLR    | AECHD     | AECCLP<br>(NLP)*1 | AECHLD<br>(ADP)*1 | AECATT<br>(ATT)*1 | AECGC<br>(GC)*1 |
| Initial value | 1                 | 0         | 0         | 0         | 0                 | 0                 | 0                 | 0               |

\*1 Names of control pins used in the MSM7602

B7 ... Acoustic echo canceler through-mode control bit

In this mode, RinA data and SinA data are through-output to RoutL and SoutL respectively.

1: Through mode 0: Normal mode (echo cancellation)

B6 ... Not used

B5 ... Selects whether or not to clear the coefficient of the adaptive FIR filter (AAFF) for the acoustic echo canceler.

1: Resets the coefficient 0: Normal operation

B4 ... Howling detector (HD) ON/OFF control

1: ON 0: OFF

B3 ... Turns ON or OFF the center clip function which forcibly sets the Sout output of the acoustic echo canceler to a minimum positive value when it is -57 dBm0 or less.

1: Center clip function ON

2: Center clip function OFF

B2 ... Selects whether or not to update the coefficient of the adaptive FIR filter (AAFF) for the acoustic echo canceler.

1: Coefficient Fixed mode

0: Normal mode (updates the coefficient.)

B1 ... Turns ON or OFF the ATT function which prevents howling from occurring by means of attenuators ATTrA and ATTsA provided for the RinA input and the SoutA output of the acoustic echo canceler.

When a signal is input to RinA only, the attenuator ATTsA of the SoutA output is activated.

When a signal is input to SinA only or to both SinA and RinA, the attenuator ATTrA of the RinA input is activated. Their ATT values are both about 6 dB.

1: ATT OFF

0: ATT ON

B0 ... Turns ON or OFF the gain control function which controls the RinA input level and prevents howling from occurring by the gain controller (GainA) for the RinA input of the acoustic echo canceler.

The gain controller starts controlling when the RIN level is -24 dBm0 or above and has the control range of 0 to -8.5 dB.

1: Gain control ON

0: Gain control OFF



(11) CR10 (External memory (flash memory) interface control)

|               | <b>B7</b>    | <b>B6</b>  | <b>B5</b>      | <b>B4</b>      | <b>B3</b> | <b>B2</b> | <b>B1</b> | <b>B0</b> |
|---------------|--------------|------------|----------------|----------------|-----------|-----------|-----------|-----------|
| CR10          | SEND/<br>REC | MEM<br>SEL | ADPCM<br>MODE1 | ADPCM<br>MODE0 | CMD3      | CMD2      | CMD1      | CMD0      |
| Initial value | 0            | 0          | 0              | 0              | 0         | 0         | 0         | 0         |

B7... Reserved (connection to the recording interface)

B6... Reserved (selection of external memory)

B5, 4... Reserved (selection of recording/playback ADPCM compression mode)

B3, 2, 1, 0 ...Reserved (memory interface command)

(0, 0, 0, 0) : NOP

(0, 0, 0, 1) : Reserved

(0, 0, 1, 0) : Reserved

(0, 0, 1, 1) : Reserved

(0, 1, 0, 0) : Reserved

(0, 1, 0, 1) : Reserved

(0, 1, 1, 0) : Reserved

(0, 1, 1, 1) : Reserved

(1, 0, 0, 0) : Reserved

(1, 0, 0, 1) : Reserved

(1, 0, 1, 0) : Reserved

(1, 0, 1, 1) : Reserved

(1, 1, 0, 0) : Reserved

(1, 1, 0, 1) : MDWR (Change default)

Writes the data of CR17 (D0 to D7) and CR16 (D8 to D15) in the lower byte of default storage memory. The address is specified by A0 to A7 of CR11 and A8 to A15 of CR12.

(1, 1, 1, 0) : Reserved

(1, 1, 1, 1) : Reserved

(12) CR11, 12, 13 (Memory address register 1)

|               | <b>B7</b>    | <b>B6</b>    | <b>B5</b>    | <b>B4</b>    | <b>B3</b>    | <b>B2</b>    | <b>B1</b>    | <b>B0</b>    |
|---------------|--------------|--------------|--------------|--------------|--------------|--------------|--------------|--------------|
| CR11          | ST7/<br>A7   | ST6/<br>A6   | ST5/<br>A5   | ST4/<br>A4   | ST3/<br>A3   | ST2/<br>A2   | ST1/<br>A1   | ST0/<br>A0   |
| Initial value | —            | —            | —            | —            | —            | —            | —            | —            |
|               | <b>B7</b>    | <b>B6</b>    | <b>B5</b>    | <b>B4</b>    | <b>B3</b>    | <b>B2</b>    | <b>B1</b>    | <b>B0</b>    |
| CR12          | ST15/<br>A15 | ST14/<br>A14 | ST13/<br>A13 | ST12/<br>A12 | ST11/<br>A11 | ST10/<br>A10 | ST9/<br>A9   | ST8/<br>A8   |
| Initial value | —            | —            | —            | —            | —            | —            | —            | —            |
|               | <b>B7</b>    | <b>B6</b>    | <b>B5</b>    | <b>B4</b>    | <b>B3</b>    | <b>B2</b>    | <b>B1</b>    | <b>B0</b>    |
| CR13          | —            | —            | —            | ST20/<br>A20 | ST19/<br>A19 | ST18/<br>A18 | ST17/<br>A17 | ST16/<br>A16 |
| Initial value | —            | —            | —            | —            | —            | —            | —            | —            |

CR11 to 13 : Registers storing an address (A0 to A20) required for the default value change command

Since CR13 is assigned “0h”, no setting is required for it.

(13) CR14, 15, 16 (Memory address register 2)

|               | <b>B7</b> | <b>B6</b> | <b>B5</b> | <b>B4</b> | <b>B3</b> | <b>B2</b> | <b>B1</b> | <b>B0</b> |
|---------------|-----------|-----------|-----------|-----------|-----------|-----------|-----------|-----------|
| CR14          | SP7       | SP6       | SP5       | SP4       | SP3       | SP2       | SP1       | SP0       |
| Initial value | —         | —         | —         | —         | —         | —         | —         | —         |
|               | <b>B7</b> | <b>B6</b> | <b>B5</b> | <b>B4</b> | <b>B3</b> | <b>B2</b> | <b>B1</b> | <b>B0</b> |
| CR15          | SP15      | SP14      | SP13      | SP12      | SP11      | SP10      | SP9       | SP8       |
| Initial value | —         | —         | —         | —         | —         | —         | —         | —         |
|               | <b>B7</b> | <b>B6</b> | <b>B5</b> | <b>B4</b> | <b>B3</b> | <b>B2</b> | <b>B1</b> | <b>B0</b> |
| CR16          | —         | —         | —         | SP20      | SP19      | SP18      | SP17      | SP16      |
| Initial value | —         | —         | —         | —         | —         | —         | —         | —         |

CR14 to 16: When the default value change command is used, the bit 7 to bit 0 of CR16 correspond to the D15 to D8 of write data.

Note : CR14 and CR15 are the reserved registers.

(14) CR17 (Memory data register)

|               | B7     | B6     | B5     | B4     | B3     | B2     | B1     | B0     |
|---------------|--------|--------|--------|--------|--------|--------|--------|--------|
| CR17          | D7/CA7 | D6/CA6 | D5/CA5 | D4/CA4 | D3/CA3 | D2/CA2 | D1/CA1 | D0/CA0 |
| Initial value | —      | —      | —      | —      | —      | —      | —      | —      |

CR17 is the register to store the data used by the default value store command.

(15) CR18 (Setting of tone detection frequency, memory address register 3)

|               | B7  | B6  | B5  | B4  | B3              | B2              | B1              | B0              |
|---------------|-----|-----|-----|-----|-----------------|-----------------|-----------------|-----------------|
| CR18          | WA7 | WA6 | WA5 | WA4 | D TONE3/<br>WA3 | D TONE2/<br>WA2 | D TONE1/<br>WA1 | D TONE0/<br>WA0 |
| Initial value | —   | —   | —   | 0   | 0               | 0               | 0               | 0               |

D TONE3 to 0: Valid only when the tone generator is operating (except for the initial mode)

B7, 6, 5, 4 ...Not used

B3, 2, 1, 0 ...Setting of a tone frequency (see Table 7)

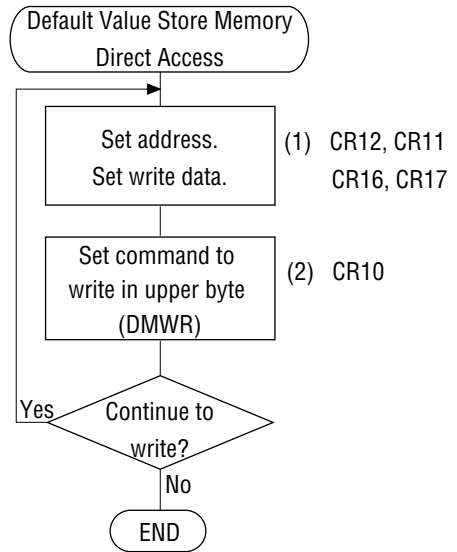
**Table 7 Setting of Tone Detector Frequencies**

| B3 | B2 | B1 | B0 | Frequency            | B3 | B2 | B1 | B0 | Frequency            |
|----|----|----|----|----------------------|----|----|----|----|----------------------|
| 0  | 0  | 0  | 0  | 697 Hz + 1209 Hz (1) | 1  | 0  | 0  | 0  | 697 Hz + 1477 Hz (3) |
| 0  | 0  | 0  | 1  | 770 Hz + 1209 Hz (4) | 1  | 0  | 0  | 1  | 770 Hz + 1477 Hz (6) |
| 0  | 0  | 1  | 0  | 852 Hz + 1209 Hz (7) | 1  | 0  | 1  | 0  | 852 Hz + 1477 Hz (9) |
| 0  | 0  | 1  | 1  | 941 Hz + 1209 Hz (*) | 1  | 0  | 1  | 1  | 941 Hz + 1477 Hz (#) |
| 0  | 1  | 0  | 0  | 697 Hz + 1336 Hz (2) | 1  | 1  | 0  | 0  | 697 Hz + 1633 Hz (A) |
| 0  | 1  | 0  | 1  | 770 Hz + 1336 Hz (5) | 1  | 1  | 0  | 1  | 770 Hz + 1633 Hz (B) |
| 0  | 1  | 1  | 0  | 852 Hz + 1336 Hz (8) | 1  | 1  | 1  | 0  | 852 Hz + 1633 Hz (C) |
| 0  | 1  | 1  | 1  | 941 Hz + 1336 Hz (0) | 1  | 1  | 1  | 1  | 941 Hz + 1633 Hz (D) |

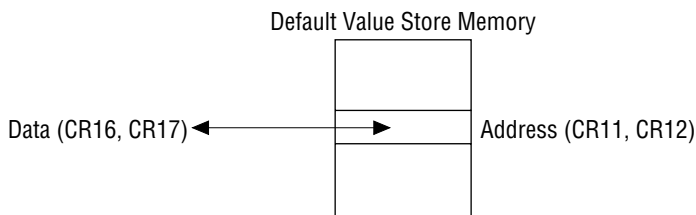
**Direct Access to Default Store Memory (See Figs.8-1, 8-2)**

The contents of the default store memory can be changed (e.g., to change tone detection levels and tone generation frequencies) in the initial mode (CR0-B3 to CR0-B0="0000"). Refer to the following procedure:

1. Set the default value store memory address (CR11, CR12).  
Set the write data into CR16 and CR17.
2. When writing data to the upper byte, set the DMWR (change default) command (CR10-B3 to CR10-B0="1101").

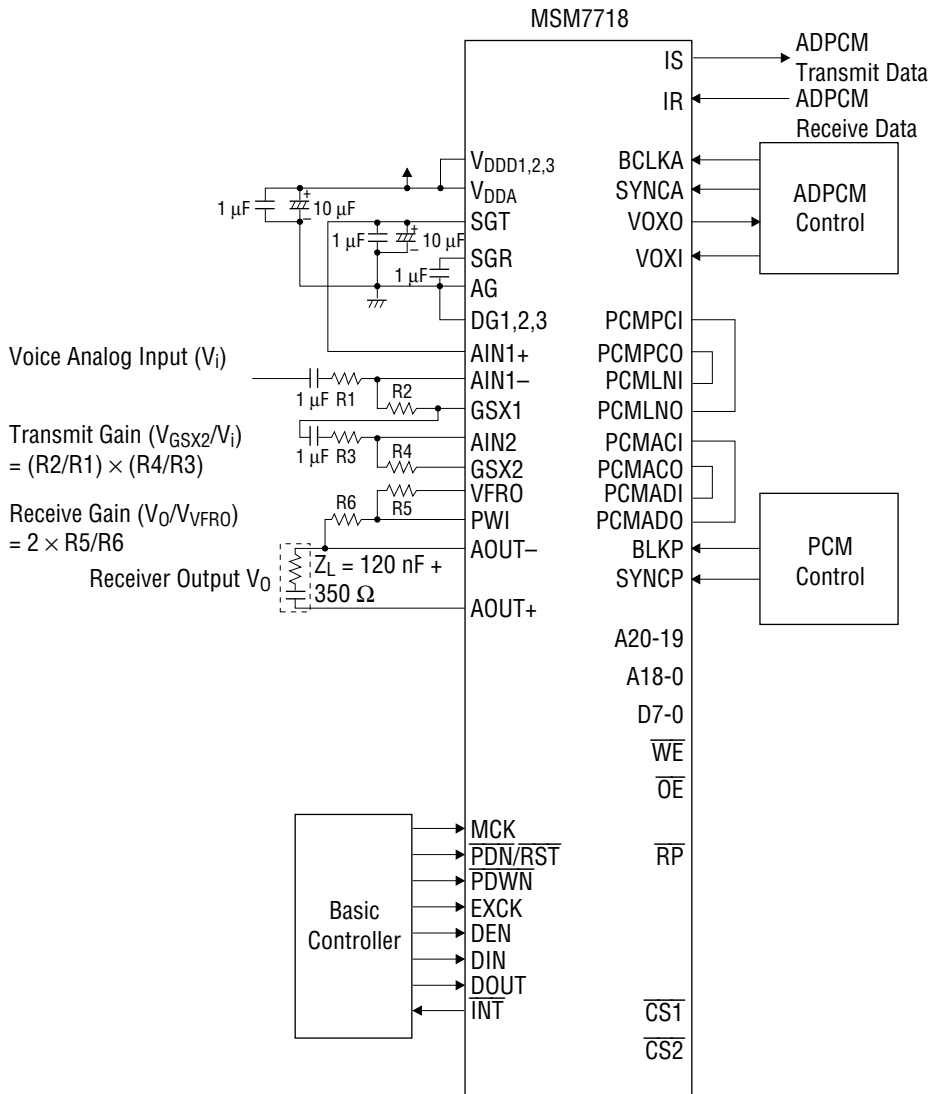


**Figure 8-1 Flow Chart of Default Value Store Memory Direct Access**



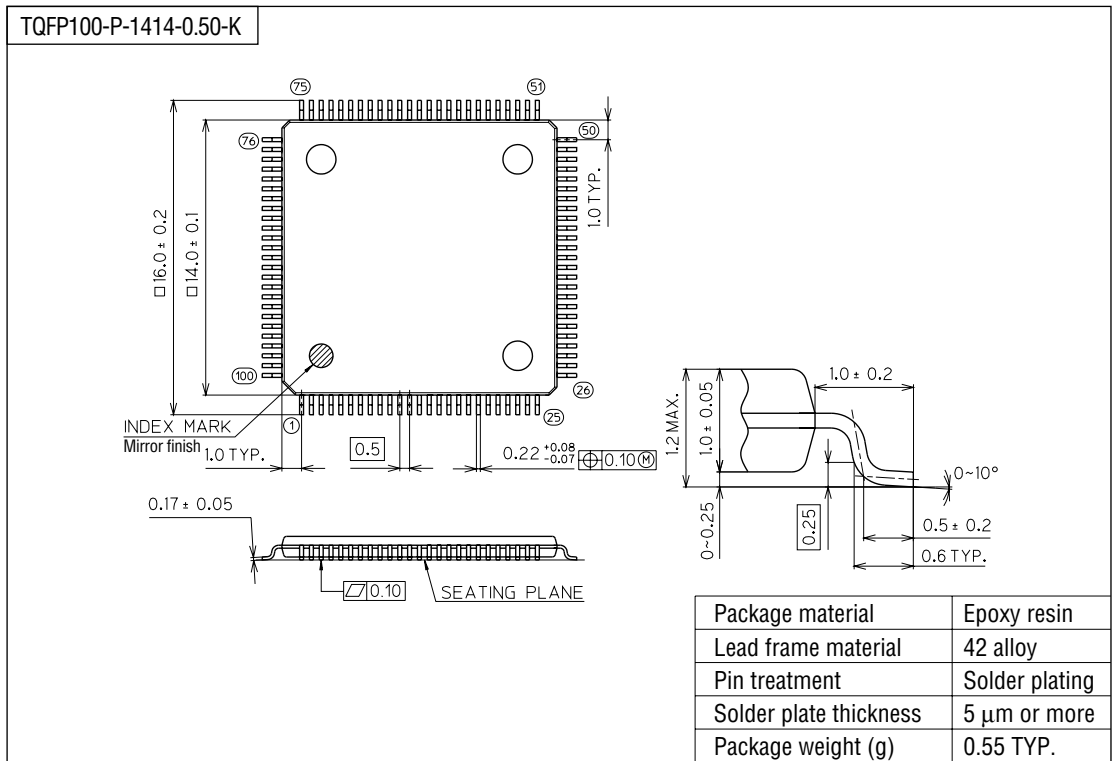
**Figure 8-2 Memory Map for Default Value Store Memory Direct Access**

APPLICATION CIRCUIT



PACKAGE DIMENSIONS

(Unit : mm)



Notes for Mounting the Surface Mount Type Package

The SOP, QFP, TSOP, SOJ, QFJ (PLCC), SHP and BGA are surface mount type packages, which are very susceptible to heat in reflow mounting and humidity absorbed in storage. Therefore, before you perform reflow mounting, contact Oki's responsible sales person for the product name, package name, pin number, package code and desired mounting conditions (reflow method, temperature and times).