

# MAXIM

## Quad SPST CMOS Analog Switches

MAX332/DG202/DG212

### General Description

Maxim's MAX332, DG202 and DG212 are normally open, quad single-pole-single-throw (SPST) analog switches. These CMOS switches can be continuously operated with power supplies ranging from  $\pm 4.5V$  to  $\pm 18V$ . Maxim guarantees that the MAX332 and DG202/212 will not latch up if their power supplies are disconnected with input signals still connected.

The MAX332 and DG202/DG212 are similar to the DG201 and DG211 except for inverted control inputs. All devices have guaranteed break-before-make switching as well as essentially constant on resistance over the analog signal range. All switches conduct current in either direction and add no offset to the output signal.

Compared to the original manufacturers products, Maxim's MAX332 and DG202/DG212 consume very little power, making them ideally suited for portable applications. Maxim has also eliminated the need for the third logic power supply ( $V_L$ ), required when operating the original manufacturer's DG212, without sacrificing compatibility.

### Applications

- Analog Multiplexers
- Programmable Gain Amplifiers
- Communications Systems
- Sample/Holds
- Automatic Test Equipment
- PBX, PABX

### Typical Operating Circuit

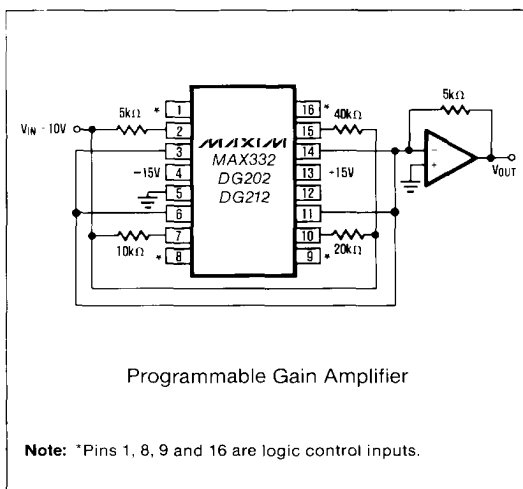

### Features

- ◆ Improved 2nd Source! (See pages 3 and 5 for "MAXIM Advantage™")
- ◆ Guaranteed  $\pm 4.5V$  to  $\pm 18V$  Operation
- ◆ No  $V_L$  Supply Required
- ◆ Non-Latching with Supplies Turned-off and Input Signals Present
- ◆ CMOS and TTL Logic Compatible
- ◆ Monolithic, Low Power CMOS Design

### Ordering Information

PART	TEMP. RANGE	PACKAGE
MAX332MJE	-55°C to +125°C	16 Lead CERDIP
DG202C/D	0°C to +70°C	Dice
DG202CJ	0°C to +70°C	16 Lead Plastic DIP
DG202CSE	0°C to +70°C	16 Lead Small Outline
DG202CK	0°C to +70°C	16 Lead CERDIP
DG202BSE	-25°C to +85°C	16 Lead Small Outline
DG202BK	-25°C to +85°C	16 Lead CERDIP
DG202AK	-55°C to +125°C	16 Lead CERDIP
DG212C/D	0°C to +70°C	Dice
DG212CJ	0°C to +70°C	16 Lead Plastic DIP
DG212CSE	0°C to +70°C	16 Lead Small Outline

### Pin Configuration

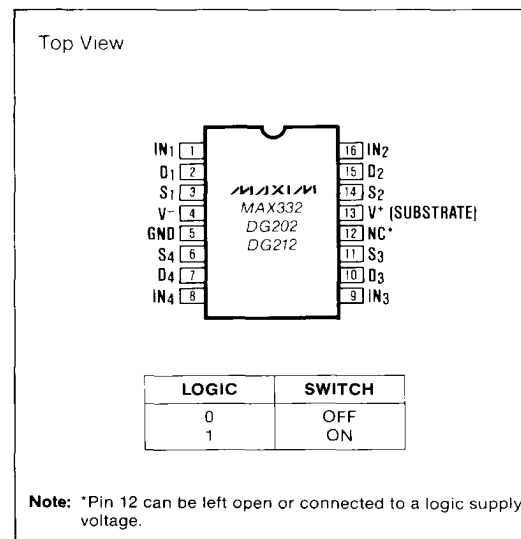

**MAXIM**

Maxim Integrated Products 1

Call toll free 1-800-998-8800 for free samples or literature.

# Quad SPST CMOS Analog Switches

## ABSOLUTE MAXIMUM RATINGS (DG212)

V <sup>+</sup> to V <sup>-</sup> .....	40V
V <sub>IN</sub> to Ground .....	V <sup>-</sup> , V <sup>+</sup>
V <sub>L</sub> to Ground .....	-0.3V, 25V
V <sub>S</sub> or V <sub>D</sub> to V <sup>+</sup> .....	0, -40V
V <sub>S</sub> or V <sub>D</sub> to V <sup>-</sup> .....	0, 40V
V <sup>+</sup> to Ground .....	25V
V <sup>-</sup> to Ground .....	-25V
Current, Any Terminal Except S or D .....	30mA
Continuous Current, S or D .....	20mA
Peak Current, S or D (Pulsed at 1msec, 10% duty cycle max) .....	70mA

Storage Temperature .....	-65°C to +125°C
Operating Temperature .....	0°C to +70°C
Power Dissipation (Note 1)	
16 Pin Plastic DIP (Note 2) .....	470mW
16 Pin Small Outline (SE) (Note 3) .....	400mW

- Note 1:** Device mounted with all leads soldered to PC board.  
**Note 2:** Derate 6.5mW/°C above +25°C.  
**Note 3:** Derate 7mW/°C above +25°C.

Stresses listed under "Absolute Maximum Ratings" may be applied (one at a time) to devices without resulting in permanent damage. These are stress ratings only, and functional operation of the device at these or any other conditions above those indicated in the operational sections of the specifications is not implied. Exposure to absolute maximum ratings conditions for extended periods may affect device reliability.

## ELECTRICAL CHARACTERISTICS (DG212)

(V<sup>+</sup> = +15V, V<sup>-</sup> = -15V, GND = 0V, T<sub>A</sub> = +25°C, unless otherwise noted)

	PARAMETER	SYMBOL	TEST CONDITIONS	LIMITS			UNITS
				MIN (Note 4)	TYP (Note 5)	MAX	
SWITCH	Analog Signal Range	V <sub>ANALOG</sub>		-15		15	V
	Drain-Source ON Resistance	r <sub>DS(on)</sub>	V <sub>D</sub> = ±10V, V <sub>IN</sub> = 2.4V, I <sub>S</sub> = 1mA		115	175	Ω
	Source OFF Leakage Current	I <sub>S(off)</sub>	V <sub>IN</sub> = 0.8V V <sub>S</sub> = 14V, V <sub>D</sub> = -14V V <sub>S</sub> = -14V, V <sub>D</sub> = 14V	-5.0	0.01	5.0	nA
	Drain OFF Leakage Current	I <sub>D(off)</sub>	V <sub>IN</sub> = 0.8V V <sub>S</sub> = 14V, V <sub>D</sub> = -14V V <sub>S</sub> = -14V, V <sub>D</sub> = 14V	-5.0	0.01	5.0	
	Drain ON Leakage Current (Note 6)	I <sub>D(on)</sub>	V <sub>S</sub> = V <sub>D</sub> = 14V, V <sub>IN</sub> = 2.4V V <sub>S</sub> = V <sub>D</sub> = -14V, V <sub>IN</sub> = 2.4V	-5.0	0.1	5.0	
				-0.15			
INPUT	Input Current With Input Voltage High	I <sub>INH</sub>	V <sub>IN</sub> = 2.4V V <sub>IN</sub> = 15V	-1.0	-0.0004	1.0	μA
	Input Current With Input Voltage Low	I <sub>INL</sub>	V <sub>IN</sub> = 0V	-1.0	-0.0004		
DYNAMIC	Turn-ON Time	t <sub>on</sub>	See Switching Time Test Circuit V <sub>S</sub> = 2V, R <sub>L</sub> = 1kΩ, C <sub>L</sub> = 35pF		460	1000	ns
	Turn-OFF Time	t <sub>off1</sub>			360	500	
		t <sub>off2</sub>			450		
	Source OFF Capacitance	C <sub>S(off)</sub>	V <sub>S</sub> = 0V, V <sub>IN</sub> = 0V, f = 1MHz		5		pF
	Drain OFF Capacitance	C <sub>D(off)</sub>	V <sub>D</sub> = 0V, V <sub>IN</sub> = 0V, f = 1MHz		5		
	Channel ON Capacitance	C <sub>D-S(on)</sub>	V <sub>D</sub> = V <sub>S</sub> = 5V, V <sub>IN</sub> = 0V, f = 1MHz		16		
OFF Isolation (Note 7)	OIRR	V <sub>IN</sub> = 0V, R <sub>L</sub> = 1kΩ, C <sub>L</sub> = 15pF, V <sub>S</sub> = 1VRMS, f = 100kHz		70		dB	
Crosstalk (Channel to Channel)	CCRR			90			
SUPPLY	Positive Supply Current	I <sup>+</sup>	V <sub>IN</sub> = 0V and 2.4V		0.35	0.48	mA
	Negative Supply Current	I <sup>-</sup>			0.30	0.48	
	Logic Supply Current	I <sub>L</sub>			0.5	1.2	

**Note 4:** The algebraic convention whereby the most negative value is a minimum, and the most positive is a maximum, is used in this data sheet.

**Note 5:** Typical values are for DESIGN AID ONLY, not guaranteed nor subject to production testing.

**Note 6:** I<sub>D(on)</sub> is leakage from driver into "ON" switch.

**Note 7:** OFF Isolation = 20 log  $\frac{V_S}{V_D}$ , V<sub>S</sub> = input to OFF switch, V<sub>D</sub> = output.

The electrical characteristics above are a reproduction of a portion of Siliconix's copyrighted 1985 data book. This information does not constitute any representation by Maxim that Siliconix's products will perform in accordance with these specifications. The "Electrical Characteristics Table" along with descriptive excerpts from the original manufacturer's data sheet have been included in this data sheet solely for comparative purposes.



## Quad SPST CMOS Analog Switches

- ◆ Significantly Reduced Power Consumption
- ◆ Third (Logic) Supply Not Required
- ◆ Fault Protected

**ABSOLUTE MAXIMUM RATINGS (DG212):** This device conforms to the Absolute Maximum Ratings on the adjacent page.

**ELECTRICAL CHARACTERISTICS (DG212):** Specifications below satisfy or exceed all "tested" parameters on adjacent page.

( $V^+ = +15V$ ,  $V^- = -15V$ ,  $GND = 0V$ ,  $T_A = +25^\circ C$ , unless otherwise noted)

	PARAMETER	SYMBOL	TEST CONDITIONS	LIMITS			UNITS
				MIN (Note 4)	TYP (Note 5)	MAX	
SWITCH	Analog Signal Range	$V_{ANALOG}$		-15		15	V
	Drain-Source ON Resistance	$r_{DS(on)}$	$V_D = \pm 10V$ , $V_{IN} = 2.4V$ , $I_S = 1mA$		115	175	$\Omega$
	Source OFF Leakage Current	$I_{S(off)}$	$V_{IN} = 0.8V$ $V_S = 14V$ , $V_D = -14V$ $V_S = -14V$ , $V_D = 14V$	-5.0	0.01	5.0	nA
	Drain OFF Leakage Current	$I_{D(off)}$	$V_{IN} = 0.8V$ $V_S = 14V$ , $V_D = -14V$ $V_S = -14V$ , $V_D = 14V$	-5.0	0.01	5.0	
	Drain ON Leakage Current (Note 6)	$I_{D(on)}$	$V_S = V_D = 14V$ , $V_{IN} = 2.4V$ $V_S = V_D = -14V$ , $V_{IN} = 2.4V$	-5.0	0.1	-0.15	
INPUT	Input Current With Input Voltage High	$I_{INH}$	$V_{IN} = 2.4V$ $V_{IN} = 15V$	-1.0	-0.0004	1.0	$\mu A$
	Input Current With Input Voltage Low	$I_{INL}$	$V_{IN} = 0V$	-1.0	-0.0004		
DYNAMIC	Turn-ON Time	$t_{on}$	See Switching Time Test Circuit $V_S = 2V$ , $R_L = 1k\Omega$ , $C_L = 35pF$		460	1000	ns
	Turn-OFF Time	$t_{off1}$			360	500	
		$t_{off2}$			450		
	Source OFF Capacitance	$C_{S(off)}$	$V_S = 0V$ , $V_{IN} = 0V$ , $f = 1MHz$		5		pF
	Drain OFF Capacitance	$C_{D(off)}$	$V_D = 0V$ , $V_{IN} = 0V$ , $f = 1MHz$		5		
	Channel ON Capacitance	$C_{D+S(on)}$	$V_D = V_S = 0V$ , $V_{IN} = 5V$ , $f = 1MHz$		16		dB
OFF Isolation (Note 8)	OIRR	$V_{IN} = 0V$ , $R_L = 1k\Omega$ , $C_L = 15pF$ , $V_S = 1VRMS$ , $f = 100kHz$		70			
Crosstalk (Channel to Channel)	CCRR				90		
SUPPLY	Positive Supply Current	$I^+$	$V_{IN} = 0V$ and $2.4V$		0.02	0.1	mA
	Negative Supply Current	$I^-$			0.00001	0.1	
	Logic Supply Current	$I_L$			0.0	0.0	
	Power Supply Range for Continuous Operation	$V_{OP}$			$\pm 4.5$		

**Note 8:** Electrical characteristics, such as ON Resistance, will change when power supplies, other than  $\pm 15V$ , are used.

MAX332/DG202/DG212

# Quad SPST CMOS Analog Switches

## ABSOLUTE MAXIMUM RATINGS (DG202)

Voltages Referenced to V <sup>-</sup>	
V <sup>+</sup> .....	44V
GND .....	25V
Digital Inputs (Note 1), V <sub>S</sub> , V <sub>D</sub> .....	-2V, to (V <sup>+</sup> +2V) or 20mA, whichever occurs first
Current, Any Terminal Except S or D .....	30mA
Continuous Current, S or D .....	20mA
Peak Current, S or D (Pulsed at 1msec, 10% duty cycle max.) .....	70mA
Operating Temperature	
DG202 (A Suffix) .....	-55°C to +125°C
(B Suffix) .....	-25°C to +85°C
(C Suffix) .....	0°C to +70°C
MAX332MJE .....	-55°C to +125°C

Storage Temperature .....	-65°C to +150°C
Power Dissipation (Note 2)	
16 Pin CERDIP (Note 3) .....	900mW
16 Pin Plastic DIP (Note 4) .....	470mW
16 Pin Small Outline (SE) (Note 5) .....	400mW

- Note 1:** Signals on S<sub>x</sub>, D<sub>x</sub>, or IN<sub>x</sub> exceeding V<sup>+</sup> or V<sup>-</sup> on Maxim's MAX332 and DG202 will be clamped by internal diodes, and are also internally current limited to 25mA.
- Note 2:** Device mounted with all leads soldered to PC board.
- Note 3:** Derate 12mW/°C above +75°C.
- Note 4:** Derate 6.5mW/°C above +25°C.
- Note 5:** Derate 7mW/°C above +25°C.

Stresses listed under "Absolute Maximum Ratings" may be applied (one at a time) to devices without resulting in permanent damage. These are stress ratings only, and functional operation of the device at these or any other conditions above those indicated in the operational sections of the specifications is not implied. Exposure to absolute maximum ratings conditions for extended periods may affect device reliability.

## ELECTRICAL CHARACTERISTICS (DG202)

(V<sup>+</sup> = +15V, V<sup>-</sup> = -15V, GND = 0V, T<sub>A</sub> = +25°C, unless otherwise noted)

	PARAMETER	SYMBOL	TEST CONDITIONS	LIMITS						UNITS
				DG202A			DG202B,C			
				MIN	TYP	MAX	MIN	TYP	MAX	
SWITCH	Analog Signal Range	V <sub>ANALOG</sub>		-15		15	-15		15	V
	Drain-Source ON Resistance	r <sub>DS(on)</sub>	V <sub>D</sub> = ±10V, V <sub>IN</sub> = 2.4V, I <sub>S</sub> = 1mA		115	175		115	200	Ω
	Source OFF Leakage Current	I <sub>S(off)</sub>	V <sub>IN</sub> = 0.8V		0.01	1.0		0.01	5.0	nA
	Drain OFF Leakage Current	I <sub>D(off)</sub>	V <sub>IN</sub> = 0.8V	V <sub>S</sub> = 14V, V <sub>D</sub> = -14V						
				V <sub>S</sub> = -14V, V <sub>D</sub> = 14V	-5.0	-0.02				
Drain ON Leakage Current (Note 8)	I <sub>D(on)</sub>	V <sub>S</sub> = -14V, V <sub>IN</sub> = 2.4V	V <sub>D</sub> = 14V, V <sub>IN</sub> = 2.4V	-1.0	-0.15		-5.0	-0.15		
			V <sub>S</sub> = 14V, V <sub>D</sub> = -14V							
INPUT	Input Current With Input Voltage High	I <sub>INH</sub>	V <sub>IN</sub> = 2.4V	-1.0	-0.0004		-1.0	-0.0004		μA
	Input Current With Input Voltage Low	I <sub>INL</sub>	V <sub>IN</sub> = 0V	-1.0	-0.0004		-1.0	-0.0004		
DYNAMIC	Turn-ON Time	t <sub>on</sub>	See Switching Time Test Circuit	480	600		480	600		ns
	Turn-OFF Time	t <sub>off</sub>		370	450		370	450		
	Charge Injection	Q	C <sub>L</sub> = 1000pF, V <sub>GEN</sub> = 0V, R <sub>GEN</sub> = 0Ω	20			20			pC
	Source OFF Capacitance	C <sub>S(off)</sub>	V <sub>S</sub> = 0V, V <sub>IN</sub> = 0V	5			5			pF
	Drain OFF Capacitance	C <sub>D(off)</sub>		5			5			
	Channel ON Capacitance	C <sub>D(on)</sub> + C <sub>S(on)</sub>	V <sub>D</sub> = V <sub>S</sub> = 0V, V <sub>IN</sub> = 5V	16			16			
	OFF Isolation		V <sub>IN</sub> = 0V, Z <sub>L</sub> = 75kΩ	70			70			
Crosstalk (Channel to Channel)		V <sub>S</sub> = 2.0V, f = 100kHz	90			90			dB	
SUPPLY	Positive Supply Current	I <sup>+</sup>	All Channels ON or OFF	0.9	2		0.9	2		mA
	Negative Supply Current	I <sup>-</sup>	All Channels ON or OFF	-1	-0.3		-1	-0.3		

**Note 6:** The algebraic convention whereby the most negative value is a minimum, and the most positive is a maximum, is used in this data sheet.

**Note 7:** Typical values are for DESIGN AID ONLY, not guaranteed nor subject to production testing.

**Note 8:** I<sub>D(on)</sub> is leakage from driver into "ON" switch.

The electrical characteristics above are a reproduction of a portion of Siliconix's copyrighted 1985 data book. This information does not constitute any representation by Maxim that Siliconix's products will perform in accordance with these specifications. The "Electrical Characteristics Table" along with descriptive excerpts from the original manufacturer's data sheet have been included in this data sheet solely for comparative purposes.



## Quad SPST CMOS Analog Switches

- ◆ Significantly Reduced Power Consumption
- ◆ Lower Input Current Over Temperature
- ◆ No Input Current Spike

**ABSOLUTE MAXIMUM RATINGS (MAX332, DG202):** This device conforms to the Absolute Maximum Ratings on the adjacent page.

**ELECTRICAL CHARACTERISTICS (MAX332, DG202):** Specifications below satisfy or exceed all "tested" parameters on adjacent page.

(V<sup>+</sup> = +15V, V<sup>-</sup> = -15V, GND = 0V, T<sub>A</sub> = +25°C, unless otherwise noted)

	PARAMETER	SYMBOL	TEST CONDITIONS	LIMITS						UNITS
				MAX332/DG202A			DG202B,C			
				MIN (Note 6)	TYP (Note 7)	MAX	MIN (Note 6)	TYP (Note 7)	MAX	
SWITCH	Analog Signal Range	V <sub>ANALOG</sub>		-15		15	-15		15	V
	Drain-Source ON Resistance (Note 9)	r <sub>DS (on)</sub>	V <sub>D</sub> = ±10V, V <sub>IN</sub> = 2.4V, I <sub>S</sub> = 1mA		115	175		115	200	Ω
	Source OFF Leakage Current	I <sub>S (off)</sub>	V <sub>IN</sub> = 0.8V V <sub>S</sub> = 14V, V <sub>D</sub> = -14V V <sub>S</sub> = -14V, V <sub>D</sub> = 14V	-1.0	-0.02		-5.0	-0.02		nA
	Drain OFF Leakage Current	I <sub>D (off)</sub>	V <sub>IN</sub> = 0.8V V <sub>S</sub> = 14V, V <sub>D</sub> = -14V V <sub>S</sub> = -14V, V <sub>D</sub> = 14V	-1.0	-0.02		-5.0	-0.02		
	Drain ON Leakage Current (Note 8)	I <sub>D (on)</sub>	V <sub>S</sub> = -14V, V <sub>IN</sub> = 2.4V V <sub>D</sub> = 14V, V <sub>IN</sub> = 2.4V	-1.0	-0.15		-5.0	-0.15		
Input Current With Input Voltage High	I <sub>INH</sub>	V <sub>IN</sub> = 2.4V V <sub>IN</sub> = 15V	-1.0	-0.0004		-1.0	-0.0004		μA	
Input Current With Input Voltage Low	I <sub>INL</sub>	V <sub>IN</sub> = 0V	-1.0	-0.0004		-1.0	-0.0004			
DYNAMIC	Turn-ON Time	t <sub>on</sub>	See Switching Time Test Circuit	480	600		480	600		ns
	Turn-OFF Time	t <sub>off1</sub>		370	450		370	450		
	Charge Injection	Q	C <sub>L</sub> = 1000pF, V <sub>GEN</sub> = 0V, R <sub>GEN</sub> = 0Ω	20			20			pC
	Source OFF Capacitance	C <sub>S (off)</sub>	V <sub>S</sub> = 0V, V <sub>IN</sub> = 0V	5			5			pF
	Drain OFF Capacitance	C <sub>D (off)</sub>	f = 140kHz	5			5			
	Channel ON Capacitance	C <sub>D (on)</sub> + C <sub>S (on)</sub>		V <sub>D</sub> = V <sub>S</sub> = 0V, V <sub>IN</sub> = 5V	16			16		
	OFF Isolation		V <sub>IN</sub> = 0V, Z <sub>L</sub> = 75kΩ	70			70			
Crosstalk (Channel to Channel)		V <sub>S</sub> = 2.0V, f = 100kHz	90			90			dB	
SUPPLY	Positive Supply Current	I <sup>+</sup>	All Channels ON or OFF	0.02	0.1		0.02	0.1		mA
	Negative Supply Current	I <sup>-</sup>	All Channels ON or OFF	-0.1	-0.01		-0.1	-0.01		
	Power Supply Range for Continuous Operation	V <sub>OP</sub>		±4.5		±18	±4.5		±18	V

**Note 6:** The algebraic convention whereby the most negative value is a minimum, and the most positive is a maximum, is used in this data sheet.

**Note 7:** Typical values are for DESIGN AID ONLY, not guaranteed nor subject to production testing.

**Note 8:** I<sub>D(on)</sub> is leakage from driver into "ON" switch.

**Note 9:** Electrical characteristics, such as ON Resistance, will change when power supplies other than ±15V, are used.

MAX332/DG202/DG212

# Quad SPST CMOS Analog Switches

## ELECTRICAL CHARACTERISTICS (DG202)

(V<sup>+</sup> = +15V, V<sup>-</sup> = -15V, GND = 0V, T<sub>A</sub> = Full Operating Temperature Range)

	PARAMETER	SYMBOL	TEST CONDITIONS	LIMITS						UNITS
				DG202A			DG202B,C			
				MIN	TYP	MAX	MIN	TYP	MAX	
SWITCH	Analog Signal Range	V <sub>ANALOG</sub>		-15	15		-15	15		V
	Drain-Source ON Resistance	r <sub>DS(on)</sub>	V <sub>D</sub> = ±10V, V <sub>IN</sub> = 2.4V, I <sub>S</sub> = 1mA			250			250	Ω
	Source OFF Leakage Current	I <sub>S(off)</sub>	V <sub>IN</sub> = 0.8V	V <sub>S</sub> = 14V, V <sub>D</sub> = -14V		100	100			nA
				V <sub>S</sub> = -14V, V <sub>D</sub> = 14V		-100	-100			
	Drain OFF Leakage Current	I <sub>D(off)</sub>	V <sub>IN</sub> = 0.8V	V <sub>S</sub> = 14V, V <sub>D</sub> = -14V		100	100			
				V <sub>S</sub> = -14V, V <sub>D</sub> = 14V		-100	-100			
	Drain ON Leakage Current (Note 10)	I <sub>D(on)</sub>	V <sub>S</sub> = -14V, V <sub>IN</sub> = 2.4V	V <sub>D</sub> = 14V, V <sub>IN</sub> = 2.4V		200	200			
INPUT	Input Current With Input Voltage High	I <sub>INH</sub>	V <sub>IN</sub> = 2.4V	-1.0			-10			μA
			V <sub>IN</sub> = 15V			-10				
	Input Current With Input Voltage Low	I <sub>INL</sub>	V <sub>IN</sub> = 0V	-10			-10			

Note 10: I<sub>D(on)</sub> is leakage from driver into "ON" switch.

The electrical characteristics above are a reproduction of a portion of Siliconix's copyrighted 1985 data book. This information does not constitute any representation by Maxim that Siliconix's products will perform in accordance with these specifications. The "Electrical Characteristics Table" along with descriptive excerpts from the original manufacturer's data sheet have been included in this data sheet solely for comparative purposes.

### Switching Time Test Circuit

Switch output waveform shown for V<sub>S</sub> = constant with logic input waveform as shown. Note that V<sub>S</sub> may be +ve or -ve as per switching times test circuit.

V<sub>O</sub> is the steady state output with switch on. Feed-through via gate capacitance may result in spikes at leading and trailing edge of output waveform.

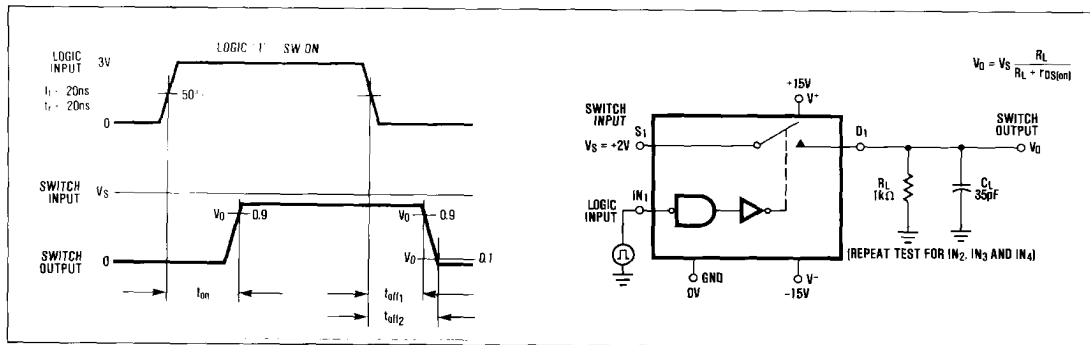

### Typical R<sub>DS(ON)</sub> vs. Power Supplies for Maxim's MAX332, DG202/DG212

POWER SUPPLIES	R <sub>DS(ON)</sub> AT ANALOG SIGNAL LEVEL					
	-5V	+5V	-10V	+10V	-15V	+15V
±5V	350Ω	380Ω				
±10V			165Ω	250Ω		
±15V			125Ω	160Ω	135Ω	155Ω



## Quad SPST CMOS Analog Switches

### ELECTRICAL CHARACTERISTICS (MAX332, DG202):

( $V^+ = +15V$ ,  $V^- = -15V$ ,  $GND = 0V$ ,  $T_A$  = full operating temperature range)

	PARAMETER	SYMBOL	TEST CONDITIONS	LIMITS				UNITS			
				MAX332/DG202A			DG202B,C				
				MIN	TYP	MAX	MIN		TYP	MAX	
SWITCH	Analog Signal Range	$V_{ANALOG}$		-15		15	-15		15	V	
	Drain-Source ON Resistance (Note 11)	$r_{DS(on)}$	$V_D = \pm 10V$ , $V_{IN} = 2.4V$ , $I_S = 1mA$			250			250	$\Omega$	
	Source OFF Leakage Current	$I_{S(off)}$	$V_{IN} = 0.8V$	$V_S = 14V$ , $V_D = -14V$ $V_S = -14V$ , $V_D = 14V$	-100			-100			nA
	Drain OFF Leakage Current	$I_{D(off)}$	$V_{IN} = 0.8V$	$V_S = 14V$ , $V_D = -14V$ $V_S = -14V$ , $V_D = 14V$	-100			-100			
	Drain ON Leakage Current (Note 10)	$I_{D(on)}$	$V_S = -14V$ , $V_{IN} = 2.4V$ $V_D = 14V$ , $V_{IN} = 2.4V$			200			200		
INPUT	Input Current With Input Voltage High	$I_{INH}$	$V_{IN} = 2.4V$ $V_{IN} = 15V$			-1.0			-1.0	$\mu A$	
	Input Current With Input Voltage Low	$I_{INL}$	$V_{IN} = 0V$			-1.0			-1.0		

Note 10:  $I_{D(on)}$  is leakage from driver into "ON" switch.

Note 11: Electrical characteristics, such as ON Resistance, will change when power supplies other than  $\pm 15V$ , are used.

MAX332/DG202/DG212

### Protecting Against Fault Conditions

Fault conditions occur when power supplies are turned off when input signals are still present or when over voltages occur at the inputs during normal operation. In either case, source-to-body diodes can be forward biased and conduct current from the signal source. If this current is required to be kept to low ( $\mu A$ ) levels then the addition of external protection diodes is recommended.

To provide protection for over-voltages up to 20V above the supplies, a 1N4001 or 1N914 type diode should be placed in series with the positive and negative supplies as shown in Fig. 1. The addition of these diodes will reduce the analog signal range to 1 volt below the positive supply and 1 volt above the negative supply.

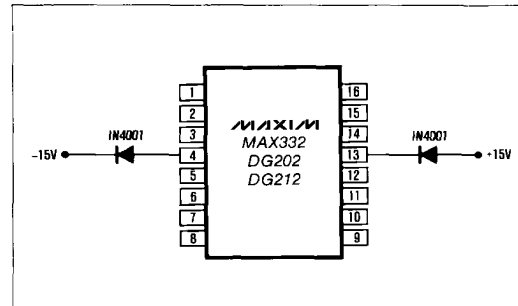
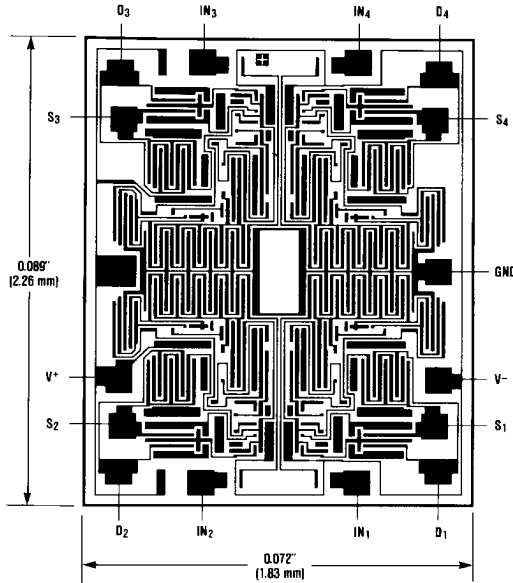

Figure 1. Protection Against Fault Conditions

# Quad SPST CMOS Analog Switches

**MAX332/DG202/DG212**

## Chip Topography



## Package Information

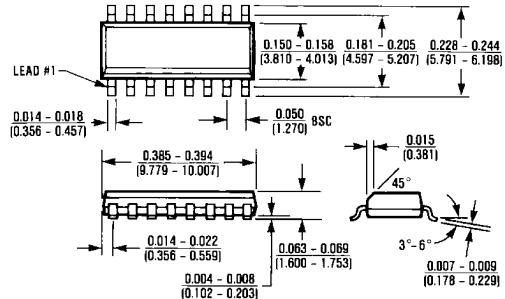

**16 Lead Small Outline (SE)**

$\theta_{JA} = 110^{\circ}\text{C/W}$

$\theta_{JC} = 60^{\circ}\text{C/W}$

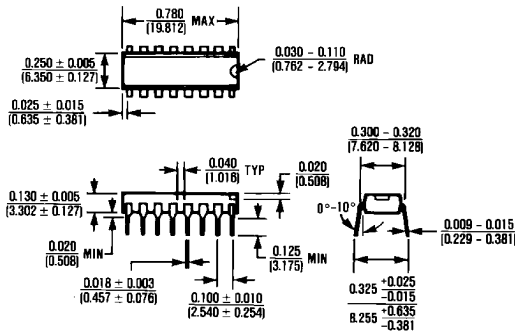

**16 Lead Plastic DIP**

$\theta_{JA} = 135^{\circ}\text{C/W}$

$\theta_{JC} = 65^{\circ}\text{C/W}$

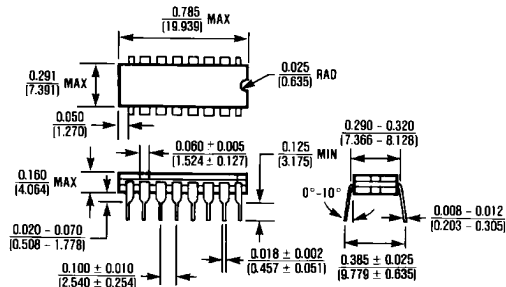

**16 Lead Cerdip**

$\theta_{JA} = 100^{\circ}\text{C/W}$

$\theta_{JC} = 60^{\circ}\text{C/W}$

Maxim cannot assume responsibility for use of any circuitry other than circuitry entirely embodied in a Maxim product. No circuit patent licenses are implied. Maxim reserves the right to change the circuitry and specifications without notice at any time.

8 **Maxim Integrated Products, 120 San Gabriel Drive, Sunnyvale, CA 94086 (408) 737-7600**

© 1995 Maxim Integrated Products

Printed USA

**MAXIM** is a registered trademark of Maxim Integrated Products.