

SYSTEM CATALOG

# Motor Solutions Guide



S E M I C O N D U C T O R

<http://www.semicon.toshiba.co.jp/eng>

# Toshiba's Semiconductors for Motor Control

Many of the digital mobile handsets, small office equipment and toy robots are battery-powered, and the controllers for small motors and actuators in these applications are required to consume little power. Toshiba is committed to the development of next-generation general-purpose motor drivers featuring low power consumption, low noise, quick response and accurate control by leveraging proprietary manufacturing and circuit technologies.

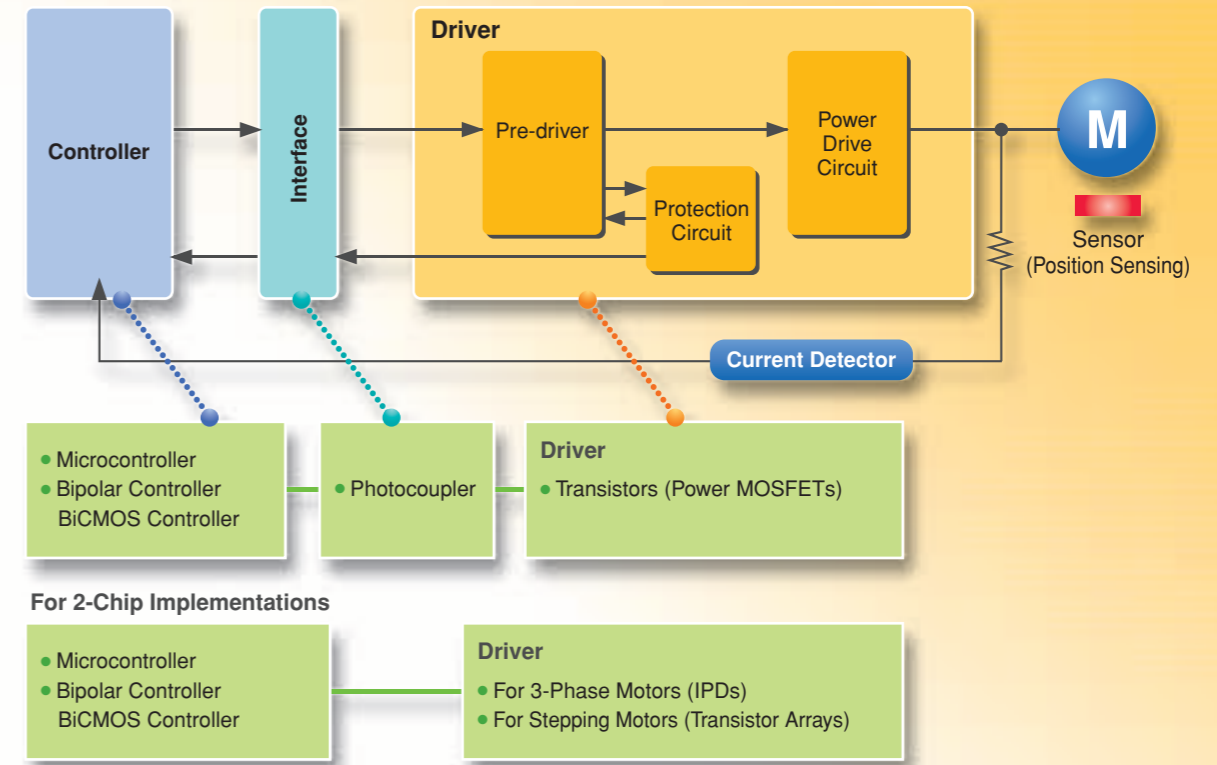

## Packaging Options for Motor Drivers and Microcontrollers

**Microcontrollers**

- QFP100
- LQFP44
- LQFP100
- LQFP48

**Motor Drivers for Battery-Powered Appliances**

- SSOP16
- VQON44
- SSOP20
- QON36
- SSOP24
- QON48
- WCSP6

**Motor Drivers for Office and Industrial Equipment**

- HZIP25
- HSIP10
- HZIP12
- HSIP7
- SIP9
- HQFP64
- HSOP20
- HSOP16
- SSOP10
- QFN36
- QFN48

**Motor Drivers for Home Appliances**

- DIP16
- SSOP24
- DIP20
- SSOP30
- QFP52
- HSOP36
- DIP26

The above package photos are not actual size.

## CONTENTS

Motor Drivers for Home Appliances .....	4, 5	Stepping Motor Drivers .....	13, 14, 15
Motor Drivers for Battery-Powered Appliances .....	6, 7	Transistor Arrays .....	15
Motor Drivers for Office and Industrial Equipment .....	8, 9	Microcontrollers .....	16, 17
Brush Motor Drivers .....	10, 11	IPDs, Power Drivers and Interface ICs .....	18, 19
Brushless Motor Drivers .....	12		

Toshiba offers a range of motor drivers ideal for inverter-powered equipment requiring low-power and quiet motor control. Toshiba designs and fabricates these motor drivers using proprietary technologies.

### Sine-Wave PWM Motor Drive Solutions

#### TB6551FG/TB6556FG/TB6584FNG

The TB6551FG, TB6556FG and TB6584FNG are three-phase brushless DC motor controllers that generate a full sine-wave PWM output. These motor controllers are specifically designed to reduce motor noise and vibration by controlling the motor drive current with a sine wave. With lead angle control and PWM control, they provide high efficiency and low power dissipation. The TB6556FG and TB6584FNG feature on-chip auto lead angle control.

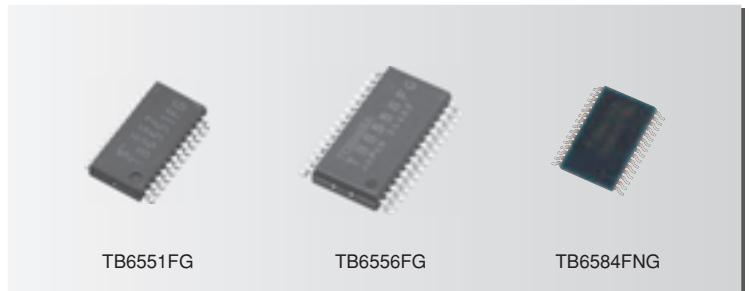

#### Features

- A true sine-wave output provides a significant reduction in acoustic noise compared to the conventional 120° commutation.
- Integrated lead angle control between 0° and 58° in 32 separate steps. This permits a wide range of motor applications through a choice of a suitable output driver.
- The phase outputs can be configured as either active-high or active-low.
- The dead-time function prevents cross conduction.
- Overcurrent protection: Forces the output signals to the inactive state to protect the output drivers if they exceed the rated voltage (Vdc = 0.5 V typ.)
- Undervoltage protection and motor rotational direction detection

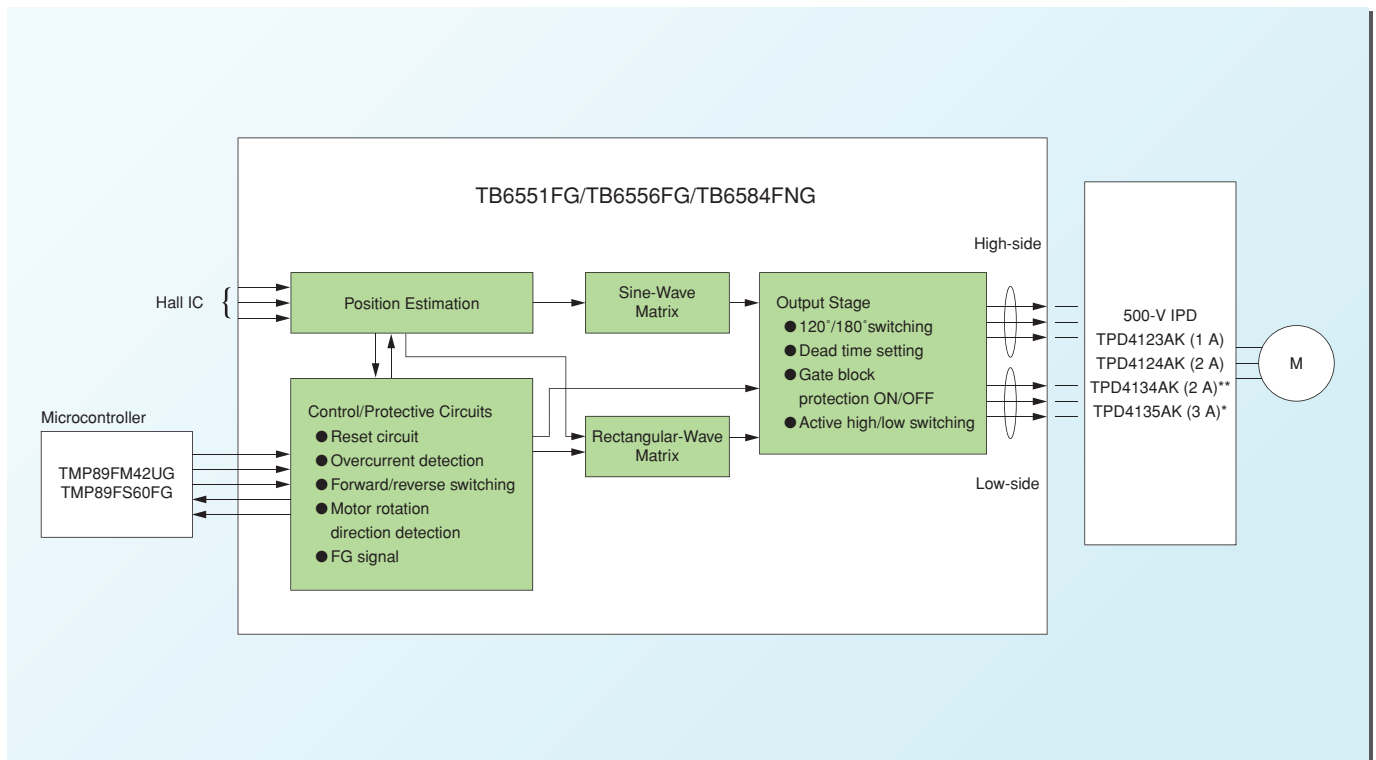

\*: New product \*\*: Under development

## Product Offerings

Part Number	Motor Type	Absolute Maximum Ratings		Characteristics	Application
		Output Breakdown	Output Current		
TB6575FNG	Brushless motors	5.5 V	20 mA	PWM sensorless controller	Air conditioners (indoor fans), washing machines, cloth drier fans, dish washer pumps
TB6588FG*		50 V	2.5 A	PWM sensorless driver	Washing machines, cloth drier fans
TB6633FNG*		25 V	1 A	PWM sensorless driver	Refrigerators (fans)
TB6586FG/AFG/BFG		18 V	2 mA	PWM controller with a turn-on angle of 150 degrees	Air conditioners (outdoor and indoor fans), kitchen fans, massage machines, water heaters, dish washer pumps
TB6551FG		12 V	2 mA	Sine-wave PWM controller	
TB6556FG		12 V	2 mA	Sine-wave PWM controller, Auto lead angle control	
TB6584FNG*		18 V	2 mA	Sine-wave PWM controller, Auto lead angle control	
TC7600FNG*		5.5 V	2 mA	Sine-wave sensorless vector control	
TB6585FG*		45 V	1.8 A	Sine-wave PWM controller	
TA7291P/FG/SG	Brush motors	25 V	2 A (1.2 A)	Vref function	Refrigerators (ice machines)

\*: New product

## Application Examples of Motor Drivers for Home Appliances

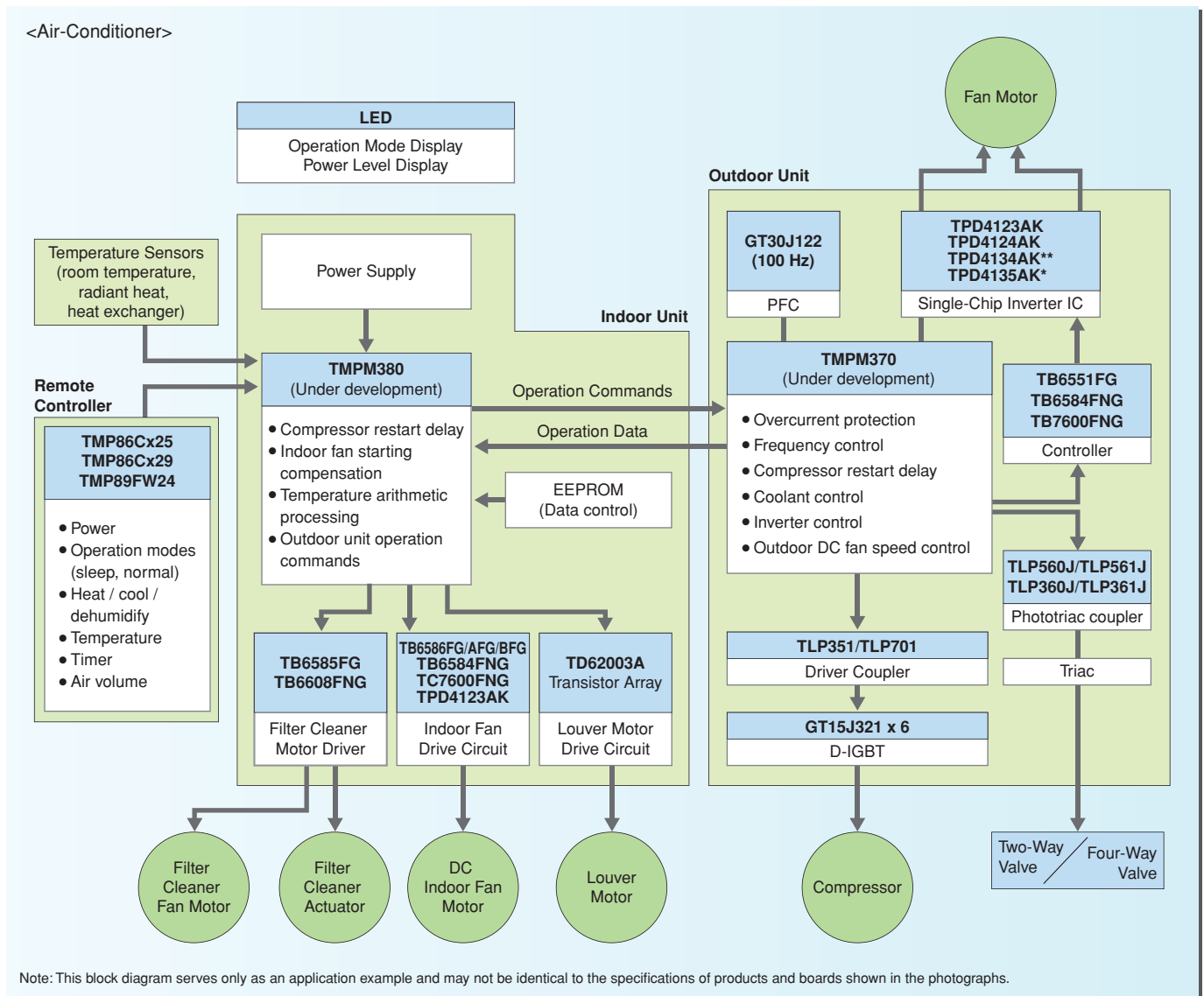

\*: New product \*\*: Under development

# Motor Drivers for Battery-Powered Appliances

## MOTOR SOLUTIONS GUIDE

Toshiba offers a range of motor drivers for portable applications that are fabricated using a new process featuring low power dissipation. These motor drivers use LDMOS transistors at the output stage to slash power loss and are available in compact leadless QON and QFN packages.

### DC Motor Drivers

#### TB6614FNG

The TB6614FNG is a DC motor driver IC using low-ON-resistance LDMOS transistors at the output stage. The IN1 and IN2 input terminals allow selection of one of the four modes: Forward, Reverse, Short Brake or Stop.

#### Features

- Power supply voltage:  $V_M = 15\text{ V}$  (max)
- Output current:  $I_{OUT} = 1.2\text{ A}$  (RMS)/3.2 A (repetitive pulse peak)
- $R_{on}$ :  $0.3\ \Omega$  typ. (high side + low side @  $V_{CC} = V_M = 5\text{ V}$ )
- Standby (power-saving) function
- Forward, reverse, short brake and stop modes
- Direct PWM control pin
- Thermal shutdown (TSD) circuitry, undervoltage detection (UVD) and overcurrent detection (ISD)
- Small surface-mount package (SSOP16 with a 0.65-mm lead pitch)

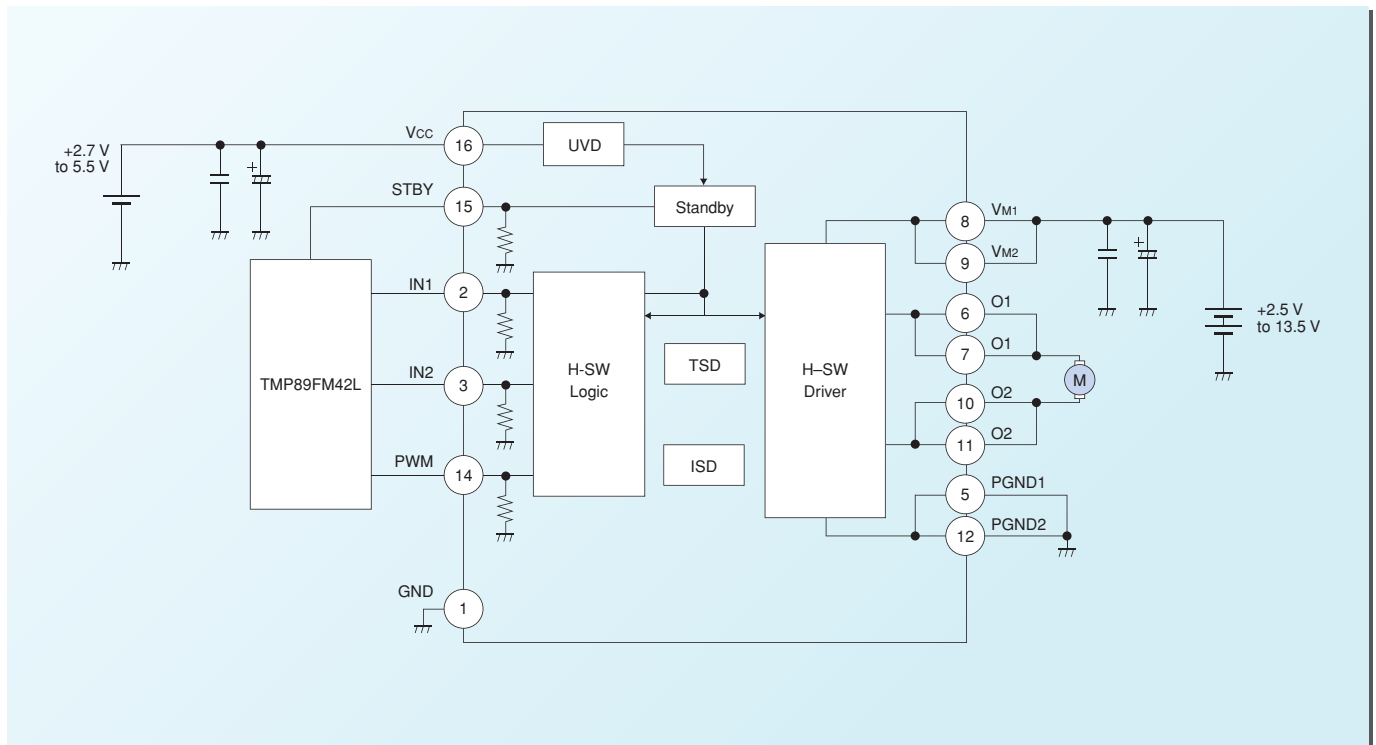

## 8-Channel Motor Driver IC for a Digital Still Camera (DSC)

### TB6613FTG

The TB6613FTG is an eight-channel DC motor driver IC using low-ON-resistance LDMOS transistors at the output stage. It incorporates five channels of constant-current H-bridge drivers for PWM chopping current control, four of which can be used to control up to two microstepping motors. This makes the TB6613FTG an ideal solution for various lens actuators of digital cameras and the like. Each driver is individually programmable through a three-wire serial interface, which minimizes the number of interconnections between the controller and the TB6613FTG.

#### Features

- 8-channel bridge drivers:
  - 3-channel full-bridge drivers + 5-channel constant-current bridge drivers (four of which can control up to two microstepping motors with either a 6-bit or 1-bit DAC)
- Absolute maximum ratings: 6 V/ 0.8 A
- Power supply voltage:  $V_{CC} = 3.0$  to  $5.5$  V  
 $V_M = 2.5$  to  $5.5$  V
- Ron:  $1.5 \Omega$
- Direct PWM control
- PWM constant-current chopper drive
- Standby function
- Thermal shutdown circuitry
- Package: VQON44

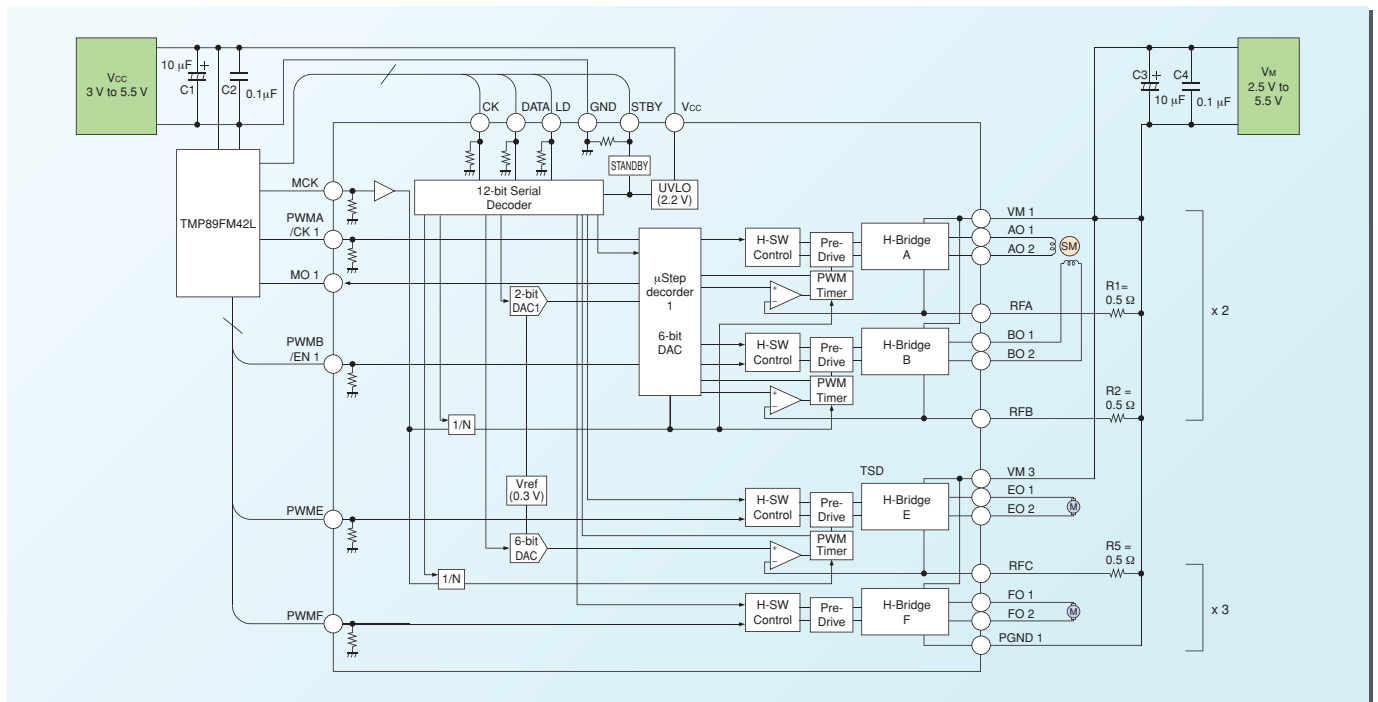

#### Product Offerings

Part Number	Motor Type	Absolute Maximum Ratings		Characteristics	Application
		Output Breakdown	Output Current		
TB6552FNG/FLG	Brush motors/ Stepping motors	15 V	1.0 A	Dual bridge	Toys, robots, digital still cameras
TB6596FLG		6 V	0.8 A	6-ch, serial interface + 6-bit DAC	Digital still cameras, robots
TB6607FLG		6 V	0.8 A	5-ch, serial interface + 6-bit DAC	
TB6609FLG		15 V	0.8 A	6-ch, serial interface + 6-bit DAC	
TB6613FTG		6 V	0.8 A	8-ch, two 6-bit microstepping drivers, serial and parallel control	
TB6593FNG		15 V	3.2 A	Single bridge	Digital still cameras, digital single-lens reflex cameras, small printers, toys
TB6612FNG		15 V	3.2 A	Dual bridge	Network cameras, small printers, small scanners
TB6608FNG		15 V	0.8 A	2W1-2-phase, constant current control	
TB6590FTG		6 V	0.5 A	Dual bridge, small VQON16 package (3 mm x 3 mm)	Digital still cameras, toys
TB6614FNG*		15 V	3.2 A	Single bridge ( $f_{PWM} \leq 400$ kHz, $R_{on} = 0.3 \Omega$ )	Digital still cameras, digital single-lens reflex cameras, small printers, toys
TB6617FNG**		40 V	2.0 A	Single bridge ( $f_{PWM} \leq 350$ kHz)	

\*: New product \*\*: Under development

# Motor Drivers for Office and Industrial Equipment

## MOTOR SOLUTIONS GUIDE

Toshiba offers a range of motor drivers for various types of motors that are designed to meet the large-current, quick-control and high-precision needs of office and industrial applications. These motor drivers leverage Toshiba's proprietary technologies such as a 40-V BiCD process and thermally enhanced packages.

### Constant-Current Chopper Stepping Motor Driver with a Micro-Step Output

#### TB6560AHQ/AFG

The TB6560AHQ/AFG is a bipolar dual-phase stepping motor driver. Fabricated with the BiCD process, the TB6560AHQ/AFG provides large current and low ON-resistance.

#### Features

- Low Ron: 0.6  $\Omega$  typ. (high side + low side)
- 2-phase to 4W1-2-phase excitation
- Selectable current decay modes for improved micro-stepping
- High-speed PWM chopping at 100 kHz or higher
- The CLK input allows MCU-less motor control.
- Ratings: 40 V/3.5 A (AHQ), 40 V/2.5 A (AFG)
- Wide supply voltage range: 4.5 to 34 V
- Packages: HZ1P25 (AHQ), HQFP64 (AFG)

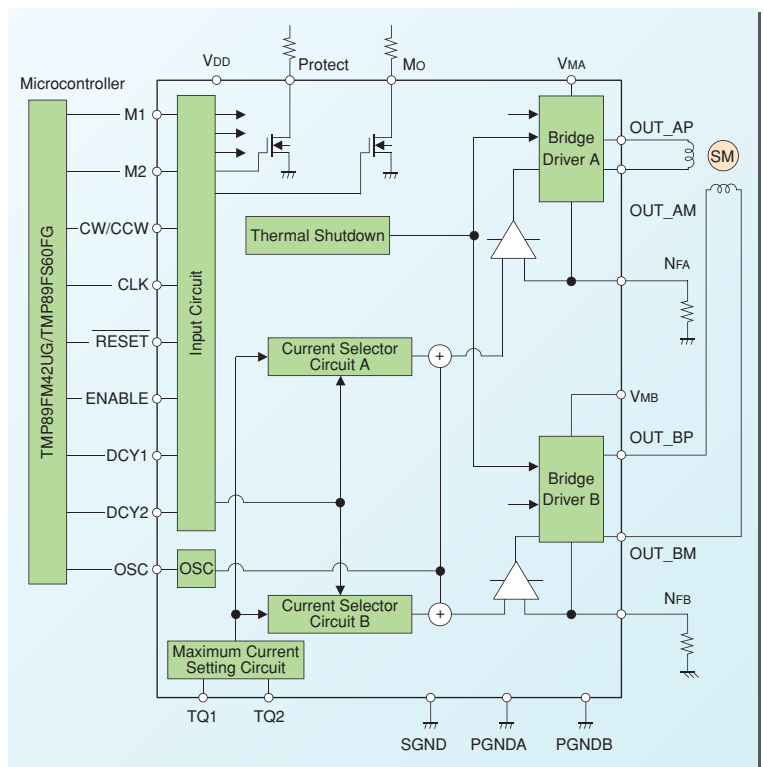

### Full-Bridge DC Motor Driver

#### TB6559FG

The TB6559FG is a full-bridge DC motor driver using complementary MOS transistors at the output stage: P-channel transistors on the high side and N-channel transistors on the low side. This eliminates the need for an external charge pump. The TB6559FG offers high thermal efficiency, thanks to selectable constant-current and direct PWM control. The IN1 and IN2 input terminals allow selection of one of the four modes: Forward, Reverse, Short Brake or Stop.

#### Features

- Power supply voltage: 50 V (max.)
- Output current: 2.5 A (max.)
- Ron: 1.3  $\Omega$  typ. (high side + low side)
- Selectable from constant-current and direct PWM control
- Standby function
- Forward, reverse, short brake and stop modes
- Overcurrent protection circuitry
- Thermal shutdown (TSD) circuitry

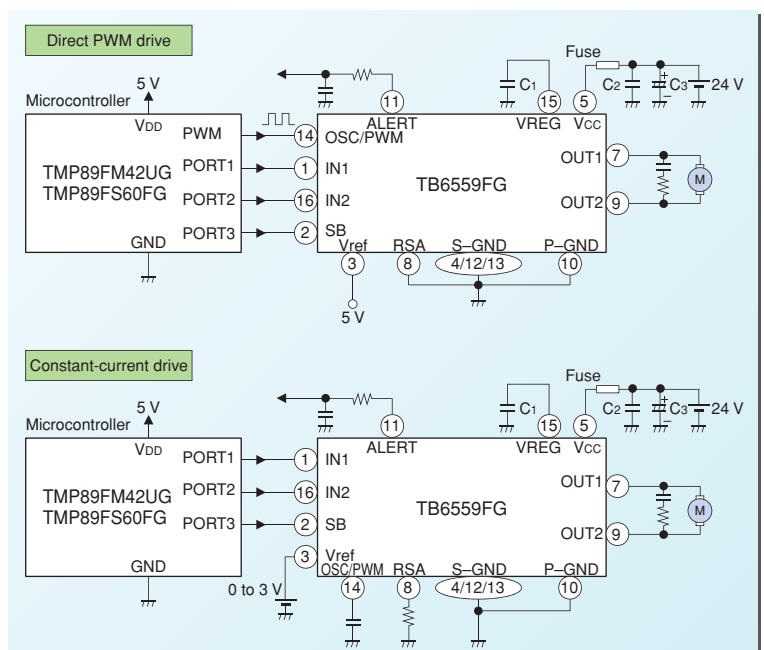

## Product Offerings

Part Number	Motor Type	Absolute Maximum Ratings		Characteristics	Application
		Output Breakdown	Output Current		
<b>TA7291SG (J)/FG</b>	Brush motors	25 V	1.2 A	Single bridge, output voltage controllable	Plain paper copiers (PPCs), printers, fax machines, vending machines, automatic teller machines (ATMs), amusement equipment, card readers, currency counters, etc.
<b>TA7291P</b>		25 V	2.0 A	Single bridge, output voltage controllable	
<b>TA8428K</b>		30 V	3.0 A	Single bridge	
<b>TA8428FG</b>		30 V	2.4 A	Single bridge	
<b>TA8429HQ</b>		30 V	4.5 A	Single bridge	
<b>TB6549FG/PG</b>		30 V	3.5 A	BiCD process, direct PWM control	
<b>TB6549HQ</b>		30 V	4.5 A	BiCD process, direct PWM control	
<b>TB6561NG/FG</b>		40 V	1.5A	BiCD process, dual bridge	
<b>TB6559FG</b>		50 V	2.5 A	Constant-current PWM control / direct PWM control, BiCD process	
<b>TB6568KQ*</b>		50 V	3.0 A	Full-bridge driver, BiCD process	
<b>TB6569FG*</b>		50 V	4.5 A	Full-bridge driver, abnormal condition output Constant-current PWM control, BiCD process	
<b>TB6551FG</b>	Brushless motors	12 V	2 mA	Sine-wave PWM controller	Industrial Fans
<b>TB6588FG*</b>		50 V	2.5 A	Sensorless control	Office printers
<b>TB6572AFG</b>		30 V	20 mA	Sine-wave PWM controller	
<b>TB6615PG</b>	Stepping motors	6 V	0.4 A	Controller	Plain paper copiers (PPCs), printers, scanners, fax machines, vending machines, automatic teller machines (ATM), amusement equipment, card readers, robots, currency counters, etc.
<b>TB6560AHQ/AFG</b>		40 V	3.5 A/2.5 A	Micro-step drive (4W1-2-phase)	
<b>TB62206FG</b>		40 V	1.8 A	1-2 phase, BiCD process	
<b>TB62209FG</b>		40 V	1.8 A	Micro-step drive, BiCD process	
<b>TB6562ANG/AFG</b>		40 V	1.5 A	W1-2 phase (1/4 step), BiCD process	
<b>TB62208FG*/FTG*/FNG**</b>	Stepping motors	40 V	1.8 A	1-2-phase, BiCD process, Phase inputs	
<b>TB62214FG*/FTG*/FNG**</b>		40 V	2.0 A	Clock input, W1-2-phase (1/4 step), BiCD process	
<b>TB62218FG*/FTG*/FNG**</b>		40 V	2.0 A	W1-2 phase (1/4 step), BiCD process, Phase inputs	
<b>TB62213FG**/FTG**/FNG**</b>		40 V	3.0 A	W1-2 phase (1/4 step), BiCD process, Phase inputs Functionally and pin-compatible with the TB62218, but with a lower Ron.	
<b>TB62215FG**/FTG**/FNG**</b>		40 V	3.0 A	Clock input, W1-2-phase (1/4 step), BiCD process Functionally and pin-compatible with the TB62214, but with a lower Ron.	
<b>TB62212FTAG/ TB62212FNG**</b>		Stepping motors /Brush motors	40 V	1.5 A/1.8 A 2.0 A/4.0 A	

\*: New product \*\*: Under development

## Automotive Actuator Applications

Part Number	Motor Type	Absolute Maximum Ratings		Characteristics	Application
		Output Breakdown	Output Current		
<b>TB9056FNG</b>	Brush motors	–	0.3 A	LIN-interface single bridge driver with LIN protocol controller, extended temperature range	Pumps
<b>TB9061FNG**</b>	Brushless motors	–	0.02 A	PWM sensorless controller, extended temperature range	
<b>TB9067FNG</b>		–	0.25 A	PWM motor controller, extended temperature range	
<b>TB9068FG**</b>		–	0.3 A	LIN interface, motor controller with on-chip drivers	

\*\* : Under development



### Full-Bridge DC Motor Driver IC

#### TB6568KQ/TB6569FG

The TB6568KQ and TB6569FG are DC motor drivers with MOS output transistors. The low-ON-resistance MOS output transistors and the PWM drive method improve thermal efficiency.

The IN1 and IN2 input terminals allow selection of one of the four modes: Forward, Reverse, Short Brake or Stop.

Housed in the HSIP7 package, the TB6568KQ is pin-compatible with the TA8428K.

The TB6569FG is offered in the HSOP16 package, a thermally enhanced surface-mount package. The TB6569FG provides an abnormal condition output, constant-current PWM control and an externally programmable overcurrent protection.

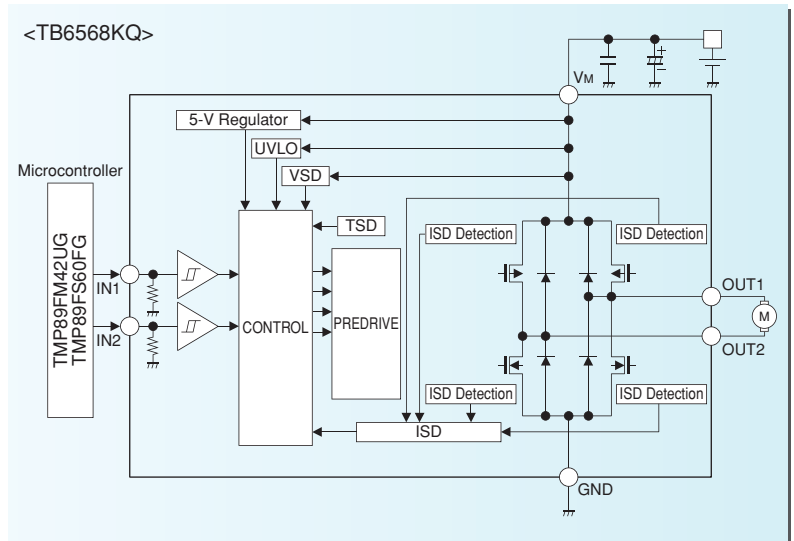

#### Features

##### (TB6568KQ/TB6569FG)

- Overcurrent protection circuitry
- Overvoltage protection circuitry
- Undervoltage lockout circuitry
- Thermal shutdown circuitry
- Cross conduction protection
- Low Ron: 0.55  $\Omega$  typ. (high side + low side)
- PWM control
- Operating voltage range: 10 to 45 V

##### (TB6568KQ)

- HSIP7 package

- Pin-compatible with TA8428K
- Rated absolute maximum output current: 3 A

##### (TB6569FG)

- HSOP16 package
- Abnormal condition output
- Constant-current PWM control
- Overcurrent protection control circuitry
- Rated absolute maximum output current: 4.0 A/4.5 A

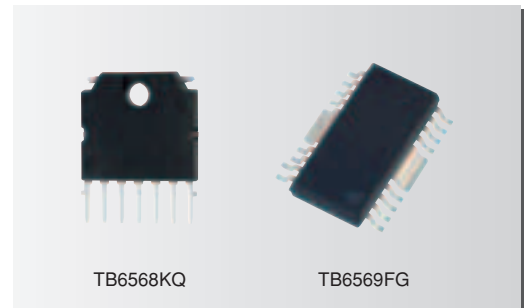

### Dual-Bridge DC Motor Driver

#### TB6552FLG/FNG

The TB6552FLG/FNG is a dual-bridge DC motor driver with low-ON-resistance LDMOS output transistors. The IN1 and IN2 input terminals allow selection of one of the four modes: Forward, Reverse, Short Brake or Stop. The PWM drive method improves thermal efficiency.

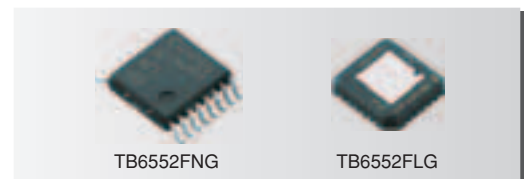

#### Features

- Dual-bridge driver
- Absolute maximum ratings: 15 V/1 A (TB6552FLG/FNG)
- Power supply voltage:  $V_{CC} = 2.7$  to 5.5 V
- $V_M = 2.5$  to 13.5 V (TB6552FLG/FNG)
- Ron: 1.5  $\Omega$  typ. (high side + low side,  $V_M = 5$  V)
- Forward, reverse, short brake and stop modes
- Direct PWM control
- Standby function
- Thermal shutdown circuitry
- Packages: QON24 (TB6552FLG) SSOP16 (TB6552FNG)

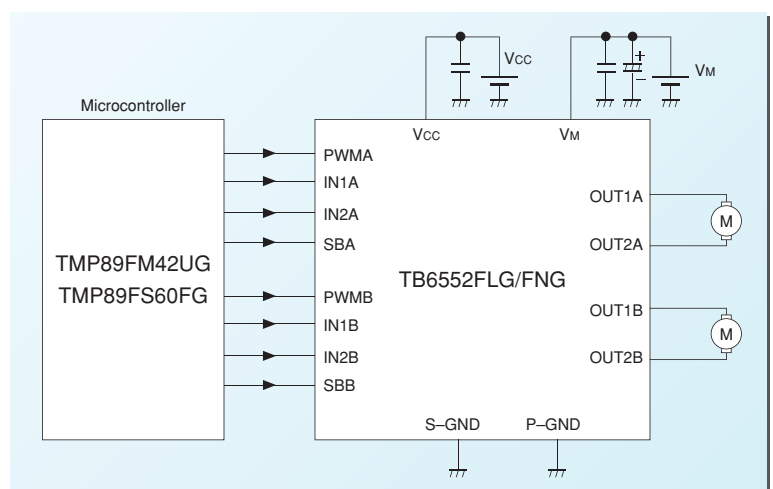

## Full-Bridge DC Motor Driver with LIN Interface

### TB9056FNG

The TB9056FNG is a full-bridge DC motor driver. Fabricated with a low-ON-resistance MOS process, the TB9056FNG offers a LIN interface for communication and allows selection of one of the four modes, Forward, Reverse, Short Brake or Stop. The TB9056FNG helps save energy with a standby leakage current of less than 10  $\mu\text{A}$ .

#### Features

- Full-bridge driver
- Operating voltage range: 7 to 18 V
- Rated absolute maximum output current: 300 mA
- LIN interface (V1.3)
- Output Ron: P-ch = 1  $\Omega$ , N-ch = 1  $\Omega$  (typ.)
- Overcurrent detection, overvoltage detection, overheat detection
- Standby leakage,  $I_{\text{leak}} = 10 \mu\text{A}$  (max)
- Extended temperature range: -40 to 85°C
- Package: SSOP24 (0.65-mm lead pitch)

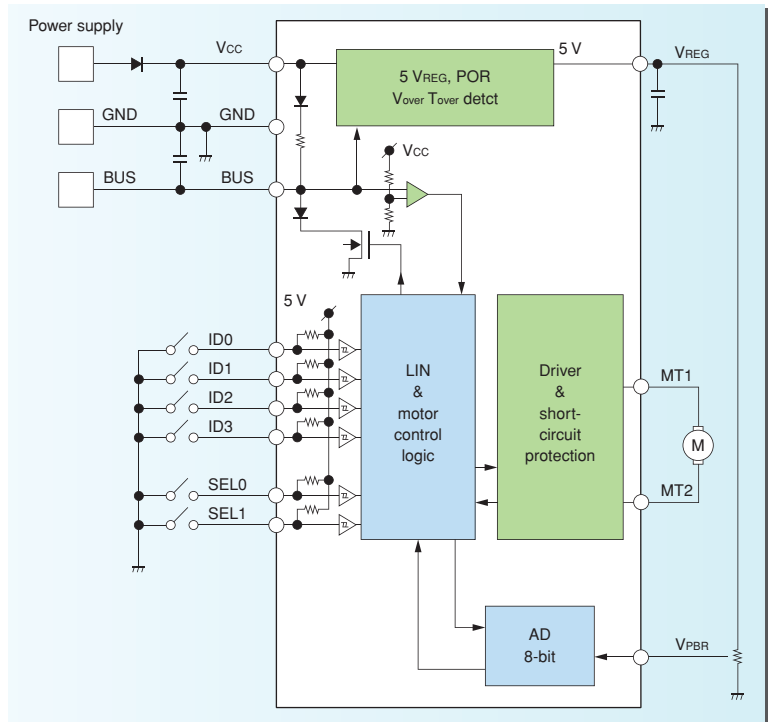

## Features of Intelligent Power Devices (IPDs)

### Power MOSFET Gate Driver for 3-Phase (H-Bridge) Motors <TPD7210F>

#### Features

- Operating voltage range: 4.5 to 18 V (Designed for 12-V power supply)
- Output current:  $\pm 1 \text{ A}$  (max)
- On-chip charge pump (Capacitors and diodes are required externally.)
- Package: SSOP24

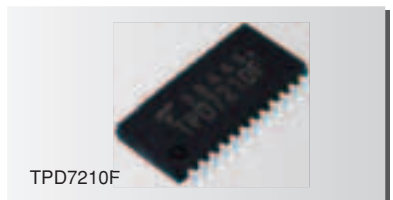

### Power MOSFET Gate Driver with Half-Bridge Outputs <TPD7211F> <Under development>

#### Features

- Operating voltage range: 5 to 18 V (Designed for 12-V power supply)
- Output current:  $\pm 500 \text{ mA}$  (max)
- The high-side driver is to drive the gate of an external P-channel power MOSFET.
- Package: Small, surface-mount PS8

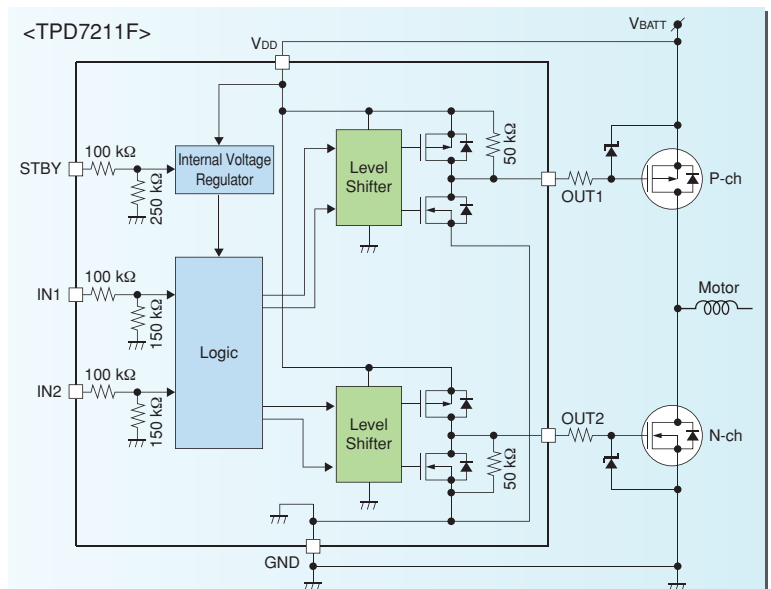

### 3-Phase Brushless DC Motor Controller with 150° Commutation and Lead Angle Control

#### TB6586FG/AFG/BFG

The TB6586FG/AFG/BFG motor controller IC has 150° commutation and provides auto lead angle control that determines the optimal turn-on point, enabling highly efficient driving of three-phase brushless motors.

#### Features

- High-side drivers are controlled with internally generated PWM signals with 150° commutation.
- Integrated bootstrap circuitry
- Auto lead angle control between 0° and 28° in 16 separate steps
- The reference clock is sourced from an external RC network.
- Overcurrent protection, reverse rotation detection, undervoltage lockout

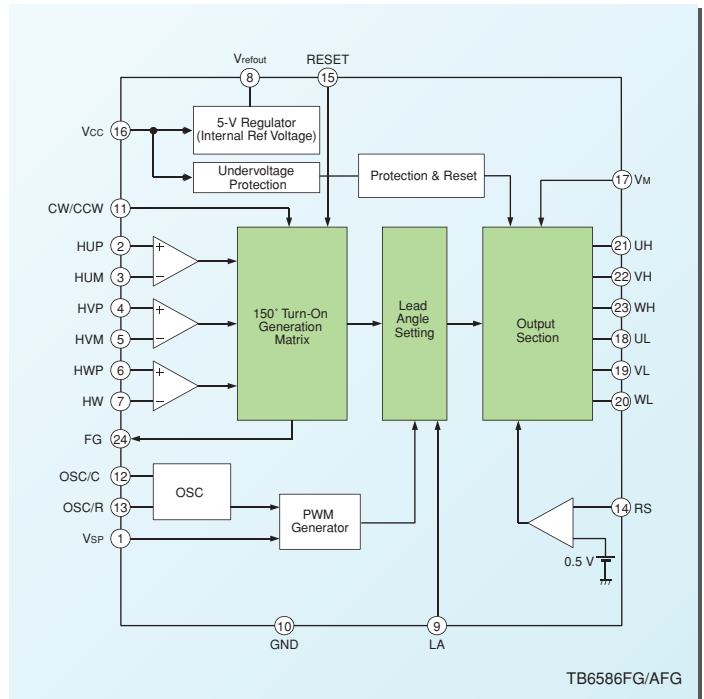
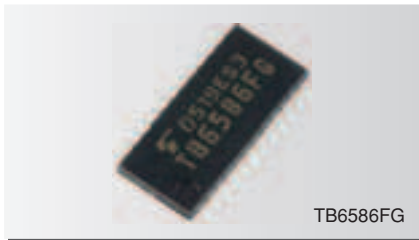

### 3-Phase Full-Wave Sensorless Brushless Motor Driver

#### TB6588FG

The TB6588FG incorporates the driver stage on the same chip, reducing the number of external components required and thus improving board utilization. The TB6588FG combines sensorless operation with hardware-based PWM motor control. It facilitates the use of smaller motors (without Hall sensors) and contributes to a reduction in power dissipation. The lap turn-on function for smooth phase current switching provides a quiet motor drive.

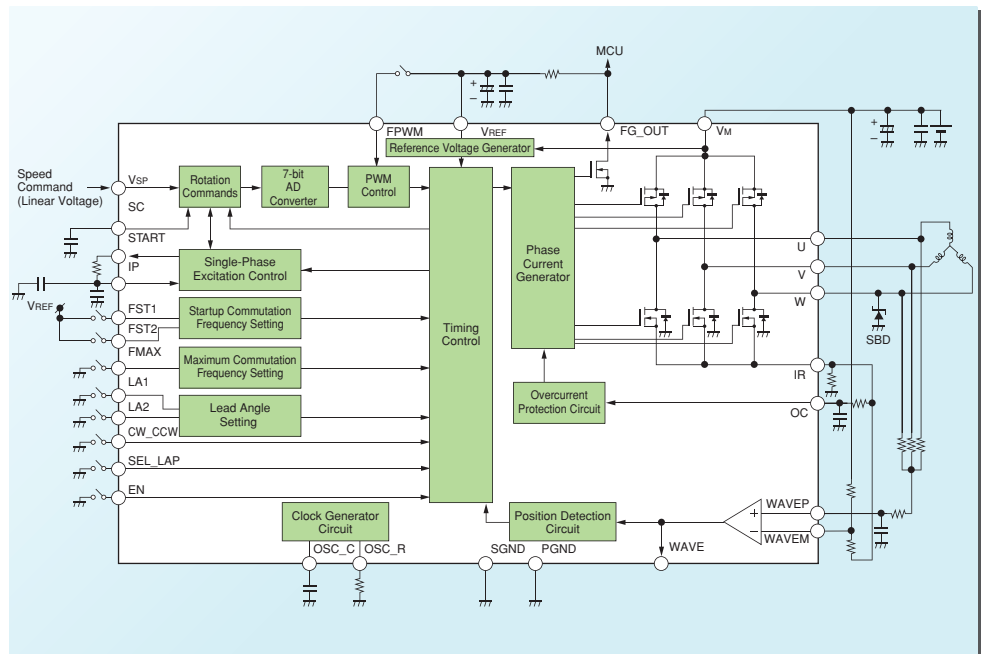

#### Features

- Three-phase, full-wave sensorless operation eliminates the need for Hall sensor feedback for motor position sensing. Only three wires are required for motor control circuitry and a motor.
- The rotation speed can be controlled with a linear voltage input.
- Four selectable lead angle settings according to the H or L level (0, 7.5, 15 or 30 degrees).
- The lap turn-on function for smooth phase current switching provides a quiet motor drive.
- An overcurrent protection circuit limits the PWM duty cycle when an overcurrent signal is detected.
- Single power supply:  $V_m = 7$  to 42 V (Rated absolute maximum voltage = 50 V)
- Output current:  $I_{OUT} = 1.5$  A (Rated absolute maximum current = 2.5 A)
- Incorporates an output driver and thus saves board space.

### Next-Generation Stepping Motor Driver Series

Two-phase constant-current bipolar stepping motor drivers fabricated using the BiCD process

- Achieved charge pump-less stepping motor drivers
- Integrated a logic voltage regulator into stepping motor drivers
- Integrated overcurrent detection, thermal shutdown and power-on reset circuits
- Mixed decay mode with improved constant-current accuracy

#### Packages

Toshiba's stepping motor drivers are available in several package styles to accommodate the needs for a variety of pc boards, applications and soldering methods.



HSOP28-P-0450-0.80

Suitable for reflow soldering

The 0.8-mm lead pitch of the HSOP package makes it ideal for reflow soldering onto paper phenolic boards and the like.

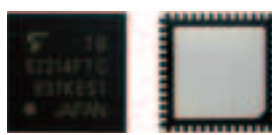

QFN48-P-0707-0.50

Suitable for space-sensitive applications

The QFN48 is a small leadless package measuring approximately 7.0 mm x 7.0 mm. It is ideal for high-density assembly onto glass-epoxy PCBs.



HTSSOP48-P-300-0.50

Thermally enhanced and easily solderable

The HTSSOP package is an ideal solution for board designs where thermal performance is a critical factor.

### Stepping Motor Driver with a Clock-In Decoder and W1-2-Phase Excitation Support

#### TB62214FG/FTG/FNG [New]

Fabricated on the BiCD process, the TB62214FG/FTG/FNG features maximum ratings of 40 V and 2.0 A and integrates a clock-in detector. The TB62214FG/FTG/FNG incorporates a voltage regulator for logic power supply, allowing single voltage ( $V_M$ ) operation.

#### Features

- Integrated clock-in decoder for motor control via a clock input
- Supports 2-phase, 1-2-phase and W1-2-phase excitation modes.
- Integrated overcurrent detection, thermal shutdown and power-on reset circuits
- Noise filter in the clock input circuitry
- Rated absolute maximum output current: 2.0 A
- Packages: HSOP28/QFN48/HTSSOP48

TB62214FG



HSOP28-P-0450-0.80

TB62214FTG



QFN48-P-0707-0.50

TB62214FNG (Under development)



HTSSOP48-P-300-0.50

#### TB62215FG/FTG/FNG <Under development>

Fabricated on the BiCD process, the TB62215FG/FTG/FNG features maximum ratings of 40 V and 3.0 A and integrates a clock-in detector. The TB62215FG/FTG/FNG incorporates a voltage regulator for logic power supply, allowing single voltage ( $V_M$ ) operation. The TB62215FG/FTG/FNG is a new stepping motor driver that is functionally and pin-compatible with the TB62214FG/FTG/FNG.

#### Features

- Integrated clock-in decoder for motor control via a clock input
- Supports 2-phase, 1-2-phase and W1-2-phase excitation modes.
- Integrated overcurrent detection, thermal shutdown and power-on reset circuits
- Noise filter in the clock input circuitry
- Rated absolute maximum output current: 3.0 A ● Ron: 0.6  $\Omega$  (high side + low side)
- Packages: HSOP28/QFN48/HTSSOP48 (Engineering samples are scheduled to be available in Q2 2010.)

### Stepping Motor Driver with W1-2-Phase Excitation Support

#### TB62218FG/FTG/FNG [New]

Fabricated on the BiCD process, the TB62218FG/FTG/FNG features maximum ratings of 40 V and 2.0 A. The TB62218FG/FTG/FNG is controlled via phase inputs and incorporates a voltage regulator for logic power supply, allowing single voltage ( $V_M$ ) operation.

#### Features

- Supports 2-phase, 1-2-phase and W1-2-phase excitation modes via three wires per phase.
- Integrated overcurrent detection, thermal shutdown and power-on reset circuits
- Rated absolute maximum output current: 2.0 A
- Packages: HSOP28/QFN48/HTSSOP48



#### TB62213FG/FTG/FNG <Under development>

Fabricated on the BiCD process, the TB62213FG/FTG/FNG features maximum ratings of 40 V and 3.0 A. The TB62213FG/FTG/FNG is controlled via phase inputs and incorporates a voltage regulator for logic power supply, allowing single voltage ( $V_M$ ) operation.

The TB62213FG/FTG/FNG is a new stepping motor driver that is functionally and pin-compatible with the TB62218FG/FTG/FNG.

#### Features

- Supports 2-phase, 1-2-phase and W1-2-phase excitation modes via three wires per phase.
- Integrated overcurrent detection, thermal shutdown and power-on reset circuits
- Rated absolute maximum output current: 3.0 A
- $R_{on}$ : 0.6  $\Omega$  (high side + low side)
- Packages: HSOP28/QFN48/HTSSOP48 (Engineering samples are scheduled to be available in Q2 2010)

### Stepping Motor Driver with 1-2-Phase Excitation Support

#### TB62208FG/FTG/FNG

Fabricated on the BiCD process, the TB62208FG/FTG/FNG features maximum ratings of 40 V and 1.8 A. The TB62208FG/FTG/FNG is controlled via phase inputs and incorporates a voltage regulator for logic power supply, allowing single voltage ( $V_M$ ) operation.

#### Features

- Supports 2-phase and 1-2-phase excitation modes via two wires per phase.
- Overcurrent detection, thermal shutdown and power-on reset
- Rated absolute maximum output current: 1.8 A
- Packages: HSOP28/QFN48/HTSSOP48

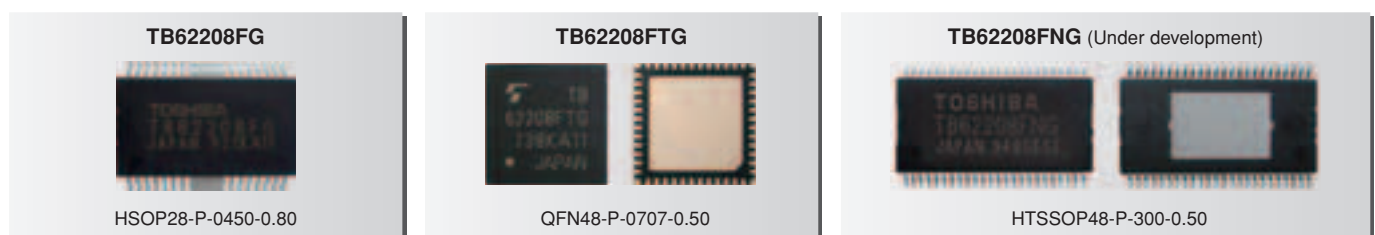

## 4-in-1 Stepping/DC Motor Driver

### TB62212FTAG/FNG

The TB62212FTAG/FNG has four-channel H bridges, making it possible to drive up to two stepping motors or up to four DC brush motors simultaneously. The TB62212FTAG/FNG can also be configured as a dual DC brush motor driver with a maximum current rating of 4.0 A.

#### Features

- H-bridges configurable into six different modes
  1. Two large DC motors:  $I_{out} = 4.0\text{ A}$
  2. Four small DC motors:  $I_{out} = 2.0\text{ A}$
  3. One large DC motor plus one small stepping motor
  4. Two small DC motors plus one small stepping motor
  5. Two small stepping motors:  $I_{out} = 1.5\text{ A}$
  6. One large stepping motor:  $I_{out} = 1.8\text{ A}$
- Overcurrent detection, thermal shutdown and power-on reset
- $R_{on}$ :  $2.2\ \Omega$  (high side + low side per H-bridge)
- Packages: QFN48  
HTSSOP48 (Under development)

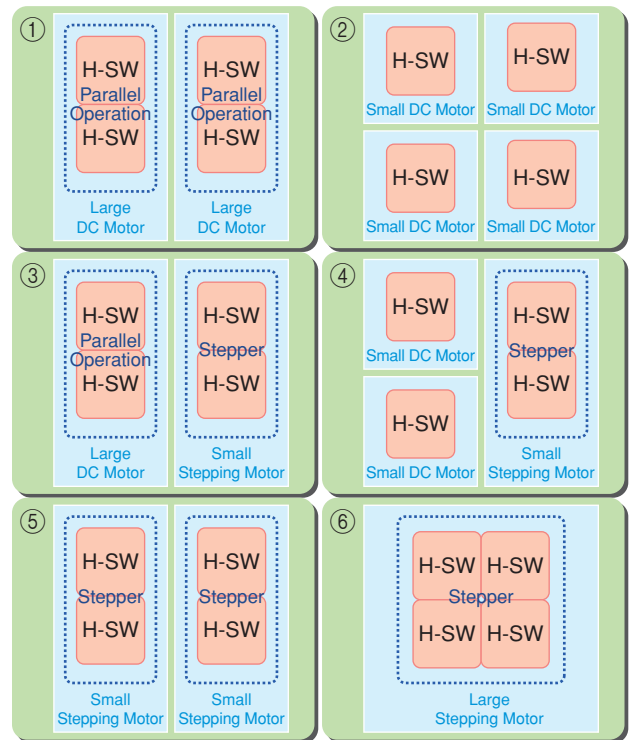

## Stepping Motor Driver ICs

Transistor arrays designed for stepping motor driving are available with a variety of functions, circuit counts, voltage and current ratings, packages and so on. Small, surface-mount SSOP packages help reduce the size of end products.

Part Number	# of Circuits	Package	Absolute Maximum Ratings		Structure/Configuration	Remarks
			Output Voltage	Output Current		
TD62064BP1G	4	DIP16-P-300-2.54A	80	1.5	Active-high transistor array	Unipolar constant-voltage drive
TD62064BFG		HSOP16-P-300-1.00				
TD62064APG		DIP16-P-300-2.54A	50	1.5		
TD62064AFG		HSOP16-P-300-1.00				
TD62308BP1G		DIP16-P-300-2.54A	80	1.5	Active-low transistor array	
TD62308BFG		HSOP16-P-300-1.00				
TD62308APG		DIP16-P-300-2.54A	50	1.5		
TD62308AFG		HSOP16-P-300-1.00				
TD62003APG	7	DIP16-P-300-2.54A	50	0.5	Active-high transistor array	
TD62004APG		SOP16-P-225-1.27				
TD62003AFG			SOP16-P-225-1.27			
TD62004AFG		SOP16-P-225-1.27				
TD62083APG	8		DIP18-P-300-2.54D	50	0.5	
TD62084APG		SOP18-P-375-1.27				
TD62083AFG			SSOP18-P-225-0.65			
TD62084AFG						
TD62083AFNG						
TD62084AFNG						

Toshiba offers a range of microcontrollers that incorporate a programmable motor driver (PMD) featuring inverter control of three-phase motors.

### Toshiba PMD Microcontroller Roadmap

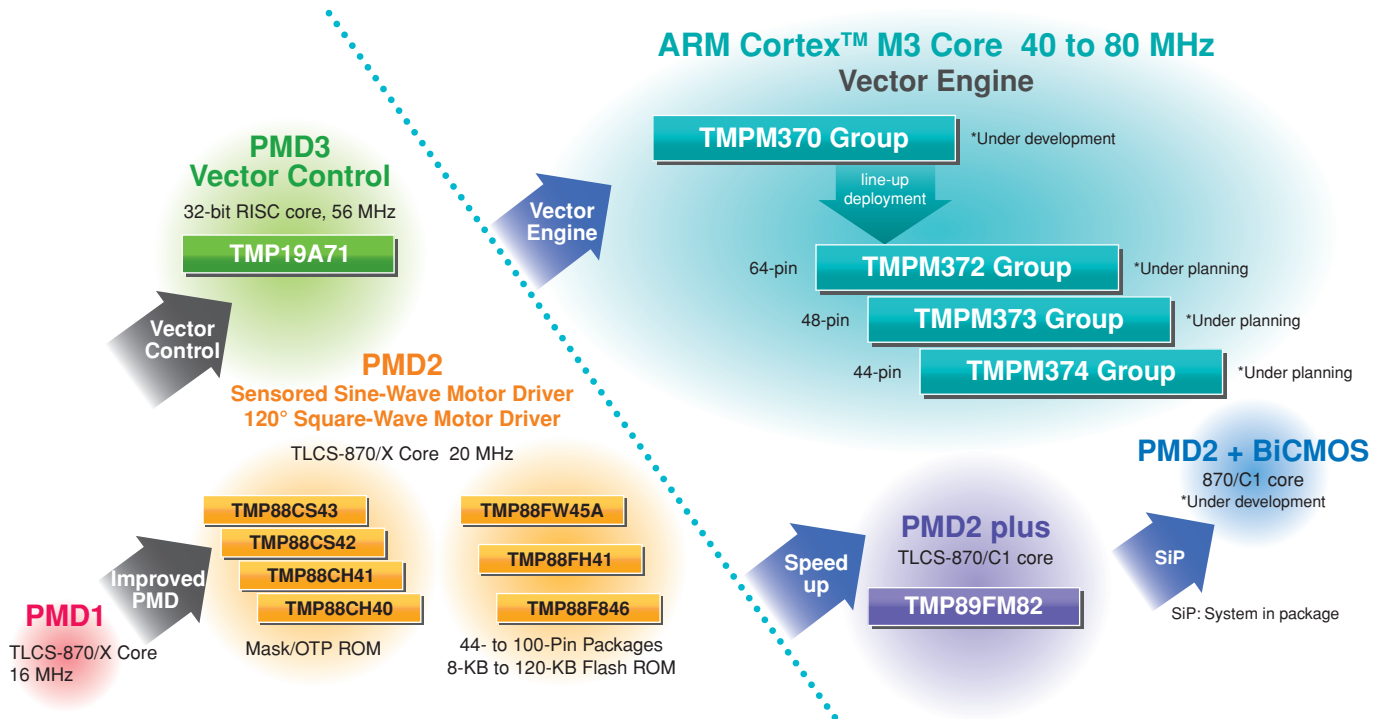

ARM and ARM Cortex are trademarks or registered trademarks of ARM Limited in the EU and other countries.

#### Vector Engine (VE)

The Vector Engine, or a hardware unit that performs routine computations such as coordinate translation, offloads the CPU from motor control tasks.

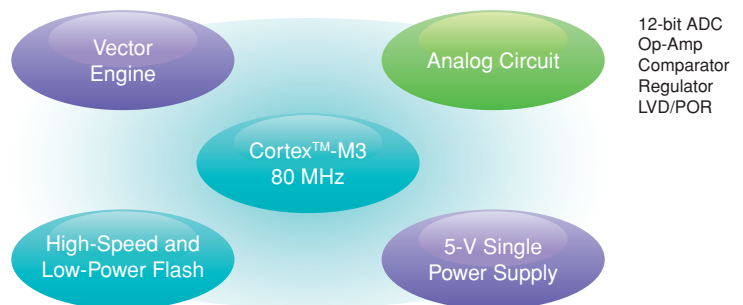

### Starter Kit with TMP89FM82DUG/TMP89FM82TDUG

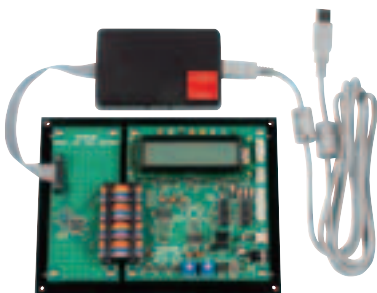

- Portable: 155 mm x 110 mm x 30 mm
- The microcontroller is exchangeable, being mounted on a separate board from the main circuit board.
- Supports an on-chip debug emulator (OCDE).
- Control from a PC is possible by connecting via a USB cable. (User-created application software is required.)
- Sample codes for three motor drive techniques (sensorless square-wave, sensored square-wave and sensored sine-wave control)
- Shows the target and current rotation speeds on a monochrome LCD (16 characters x 2 lines).

## Cortex™-M3 Core and Vector Motor Control Engine

### TMPM370FYFG <Under development>/TMPM370FYDFG <Under development>

- ARM Cortex™-M3 CPU core
  - ▶ Operating voltage: I/O = 4.5 to 5.5 V
  - ▶ Maximum operating frequency: 80 MHz (derived by multiplying a 10-MHz clock by a factor of 8 with on-chip PLL)
  - ▶ On-chip memory: 256-KB flash ROM, 10-KB RAM
  - ▶ High-speed computation: Multiplier (1-7 cycles), divider (2-12 cycles)
  - ▶ On-chip debug logic: JTAG or 2-wire SWD (Serial Wire Debug) interface
  - ▶ Low-power: Clock gearing (f/1, f/2, f/4, f/8 or f/16), operation mode (NORMAL/STOP)
- On-chip peripherals
  - ▶ Next-generation PMDs (motor control timers): 2 channels
    - Vector Engine: 1 channel
    - Encoder inputs: 2 channels
    - Comparator for emergency stop
  - ▶ 12-bit AD converter: 2- $\mu$ s conversion time, 2 unit, 22-channel ADCs (with three channels sharing the same pins)
  - ▶ 16-bit timer/counter: 8 channels (free-run, compare output, PPG, input capture)
  - ▶ Serial interface: 4 UART/SIO channels
  - ▶ Watchdog timer (WDT)      ▶ Power-on reset (POR)
  - ▶ Low voltage detection (LVD)   ▶ Oscillation frequency detection (OFD)

- Packages
  - ▶ 100-pin LQFP (14 x 14 mm, 0.5-mm lead pitch)
  - ▶ 100-pin QFP (14 x 20 mm, 0.65-mm lead pitch)

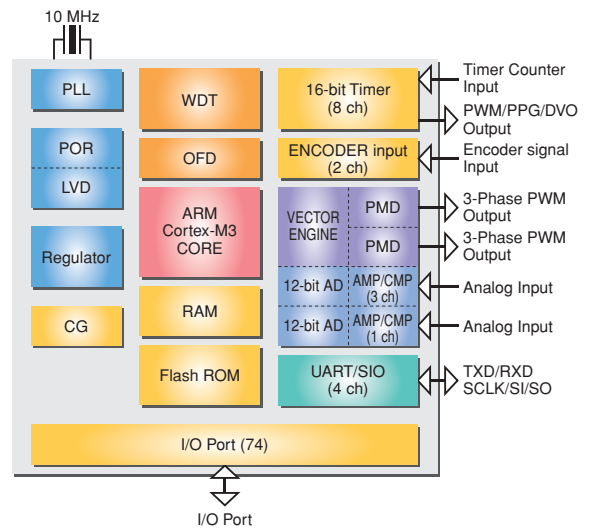

ARM and ARM Cortex are trademarks or registered trademarks of ARM Limited in the EU and other countries.

## TLCS-870/C1 Core and Sensored Sine-Wave/120° Square-Wave Motor Controller

### TMP89FM82DUG/TMP89FM82TDUG

- Improved instruction throughput due to the TLCS-870/C1 core
- The TLCS-870/C1 core provides an execution rate of one instruction per machine cycle, which translates to 1.6 times the performance of its predecessor.

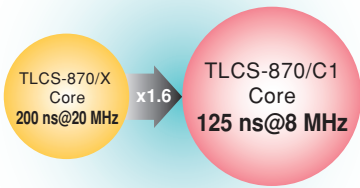

- On-chip debug features
- The on-chip debug features simplify the evaluation of motor software.



This product uses SuperFlash® technology under the license of Silicon Storage Technology, Inc. SuperFlash® is a registered trademark of Silicon Storage Technology, Inc.

- TLCS-870/C1 CPU core
  - ▶ Operating voltage: 4.5 to 5.5 V
  - ▶ Minimum instruction execution time: 125 ns @ 8 MHz / 4.5 to 5.5 V
  - ▶ On-chip memory: 32-KB flash ROM, 2-KB RAM

- On-chip peripherals
  - ▶ Programmable Motor Driver: 1 channel
    - PWM resolution: 42 ns
    - Dead time counter resolution: 83 ns
    - Sine-wave control
    - Sensorless and sensored DC motor control
    - Inverter AC motor control
    - Overload protection
    - Automatic commutation; real-time position sensing
  - ▶ 10-bit AD converters: 8 channels
  - ▶ 8-bit timers: 4 channels
  - ▶ 16-bit timers: 2 channels
  - ▶ UART/SIO: 1 channel
  - ▶ SEI/UART: 1 channel
  - ▶ Power-on reset circuit
  - ▶ Low voltage detection

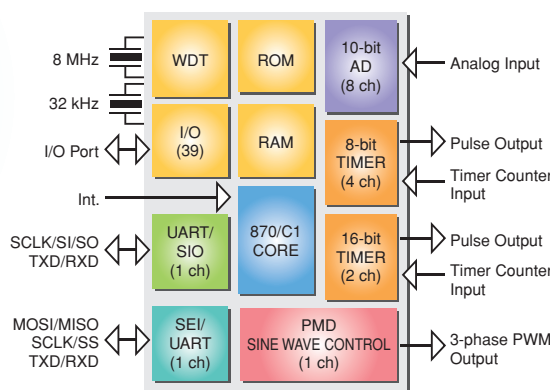

- Package
  - ▶ 48-pin LQFP (7 x 7 mm, 0.5-mm lead pitch)



### 250/500-V Brushless DC Motor Drivers Fabricated Using a Silicon-On-Insulator (SOI) Process

#### Single-Chip Inverters (IPDs): High-Voltage PWM Brushless DC Motor Drivers

Traditionally, a variable-voltage switching power supply was required to drive brushless DC motors. Toshiba's single-chip inverters, fabricated using a high-voltage monolithic process, eliminate the need for a buck converter, making it possible to be directly powered from commercial mains. Single-chip inverters are available in the new DIP26 package, which exhibits improved physical and thermal characteristics compared to the conventional HZIP23 package.

- Features**
- High withstand voltage due to the use of the SOI process and trench isolation structure
  - Available with ratings from 250 V/1A to 500 V/3A
  - Internal bootstrap power supply for the high-side gate drives

#### IPDs in the New DIP26 Package

- Features**
- Package: 26-pin DIP (NEW-DIP)
  - Package body thickness: 3.8 mm max
  - 16 control pins and 10 high-voltage pins are isolated on the opposite sides of the package.  
(This simplifies board trace routing.)
  - Improved thermal resistance

New Product

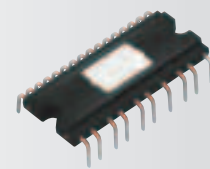

DIP26

<TPD4121K/TPD4122K Block Diagram>

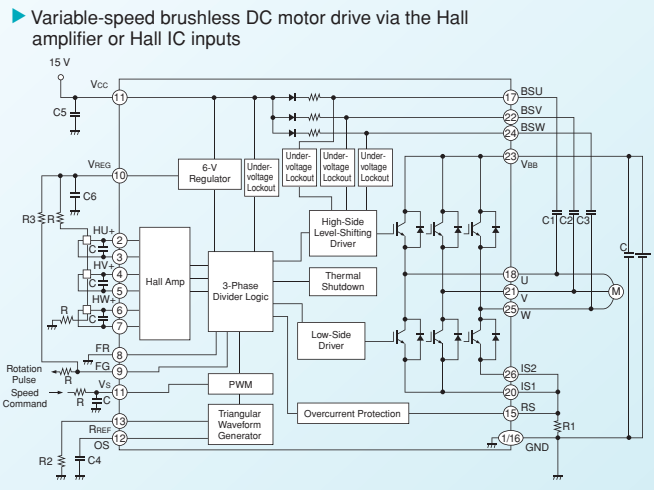

<TPD4123K/TPD4124K/TPD4134K\*/TPD4135K Block Diagram>

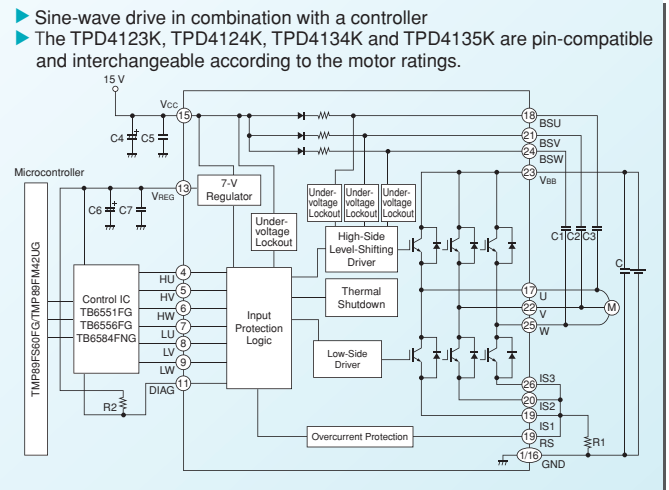

\*: Under development

#### Product Offerings

Part Number	Rating	Features						
		Hall-Effect Sensor Input	6 Inputs	Three-Phase Distribution	Level Shifter	Overcurrent Protection	Thermal Shutdown	Undervoltage Protection
TPD4121K	250 V/1 A	○	—	○	○	○	○	○
TPD4122K	500 V/1 A	○	—	○	○	○	○	○
TPD4123K	500 V/1 A	—	○	—	○	○	○	○
TPD4123AK	500 V/1 A	—	○	—	○	○	○	○
TPD4124K	500 V/2 A	—	○	—	○	○	○	○
TPD4124AK	500 V/2 A	—	○	—	○	○	○	○
TPD4134K**	500 V/2 A	—	○	—	○	○	○	○
TPD4134AK**	500 V/2 A	—	○	—	○	○	○	○
TPD4135K	500 V/3 A	—	○	—	○	○	○	○
TPD4135AK	500 V/3 A	—	○	—	○	○	○	○

\*\* : Under development

## Power Drivers

Power MOSFETs with an integrated high-speed diode: Achieves a higher parasitic-diode speed by using lifetime control.

### Product Offerings

High-Speed Diode (HSD) Series

Part Number	Absolute Maximum Rating			Package	R <sub>DS(ON)</sub> (Ω) V <sub>GS</sub> = 10 V		T <sub>rr</sub> Typ. (ns)	Series
	V <sub>DSS</sub> (V)	I <sub>D</sub> (A)	P <sub>D</sub> (W)		Typ.	Max		
2SK3868	500	5	35	TO-220SIS	1.3	1.7	150	π-MOSV
TK5A50D5*			35	TO-220SIS	1.7	2.1	130	π-MOSVII
2SK3417			50	TO-220FL/SM	1.6	1.8	60	π-MOSV
TK7A50D5*		7	35	TO-220SIS	1.4	1.68	130	π-MOSVII
2SK4042		8	40	TO-220SIS	0.7	0.97	190	π-MOSVI
TK12A50D5		12	45	TO-220SIS	0.5	0.73	120	π-MOSVII
2SK3314		15	150	TO-3P(N)	0.35	0.49	105	π-MOSV
2SK3936		23	150	TO-3P(N)	0.2	0.25	380	π-MOSVI
2SK3131		50	250	TO-3P(L)	0.085	0.11	105	π-MOSVI
TK4A60DA5*		3.5	35	TO-220SIS	2.46	3.08	130	π-MOSVII
TK4A60D5*	4	35	TO-220SIS	1.9	2.38	130	π-MOSVII	
2SK3947	6	40	TO-220SIS	1.1	1.4	150	π-MOSVI	
2SK4015	600	10	45	TO-220SIS	0.6	0.86	170	π-MOSVI
TK10A60D5*			45	TO-220SIS	0.8	1.0	90	π-MOSVII
2SK4016		13	50	TO-220SIS	0.33	0.5	160	π-MOSVI
2SK3906		20	150	TO-3P(N)	0.27	0.33	400	π-MOSVI

\*: Under development (preliminary design specs)

### Characteristics of High-Speed Diode Series

Faster parasitic diode

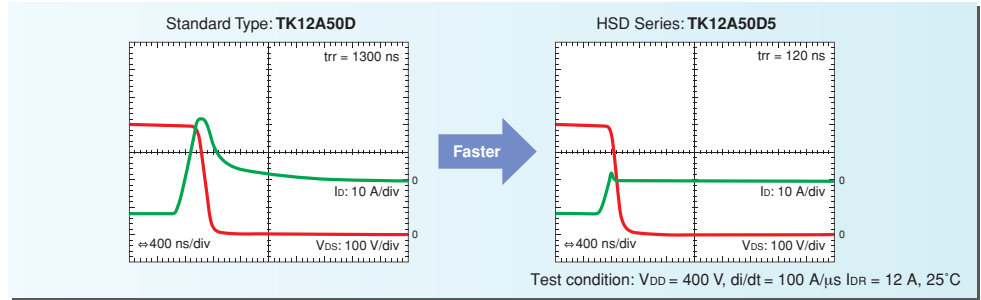

## IGBT/Power MOSFET Gate Driver Photocouplers

Toshiba offers photocouplers specifically designed for power device gate driving. The newly released TLP358H features a peak output current of ±6 A and an operating temperature as high as 125°C, whereas the TLP2451 in the small, thin SO8 package offers a peak output current of ±0.6 A and an operating temperature up to 125°C. Toshiba offers a wide selection of photocouplers to meet your unique need.

Characteristics	TLP358H	TLP350	TLP351	TLP700	TLP701	TLP705	TLP2451
Peak output current (max)	±6.0 A	±2.5 A	±0.6 A	±2.0 A	±0.6 A	±0.45 A	±0.6 A
Supply voltage	15 to 30 V	15 to 30 V	10 to 30 V	15 to 30 V	10 to 30 V	10 to 20 V	10 to 30 V
Propagation delay time (max)	500 ns	500 ns	700 ns	500 ns	700 ns	200 ns	700 ns
Operating temperature range	-40 to 125°C	-40 to 100°C	-40 to 100°C	-40 to 100°C	-40 to 100°C	-40 to 100°C	-40 to 125°C
Supply current (max)	2 mA	2 mA	2 mA	2 mA	2 mA	3 mA	2 mA
Threshold input current (max)	5 mA	5 mA	5 mA	5 mA	5 mA	8 mA	5 mA
Common-mode transient immunity (min)	±15 kV/μs	±15 kV/μs	±10 kV/μs	±15 kV/μs	±10 kV/μs	±10 kV/μs	±15 kV/μs
Isolation voltage (min)	3750 Vrms	3750 Vrms	3750 Vrms	5000 Vrms	5000 Vrms	5000 Vrms	3750 Vrms
Packaging	DIP8			SDIP6			SO8

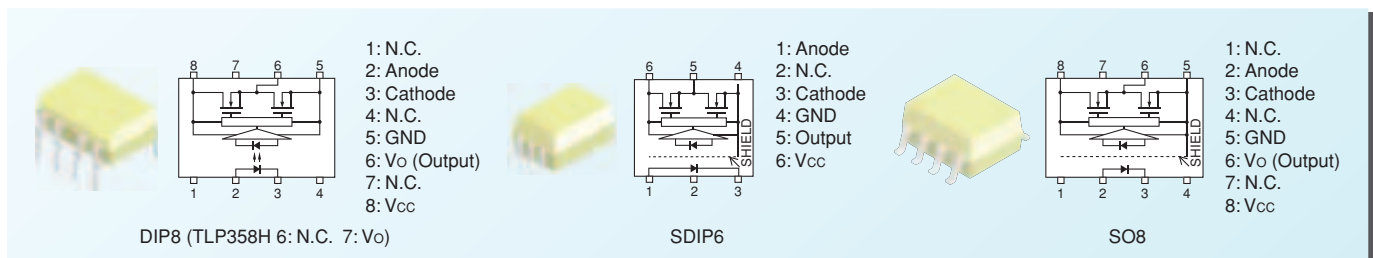

**Toshiba America****Electronic Components, Inc.**

- Irvine, Headquarters  
Tel: (949)623-2900 Fax: (949)474-1330
- Buffalo Grove (Chicago)  
Tel: (847)484-2400 Fax: (847)541-7287
- Duluth/Atlanta  
Tel: (770)931-3363 Fax: (770)931-7602
- El Paso  
Tel: (915)771-8156
- Houston  
Tel: (713)466-6277
- Marlborough  
Tel: (508)481-0034 Fax: (508)481-8828
- Parsippany  
Tel: (973)541-4715 Fax: (973)541-4716
- San Jose  
Tel: (408)526-2400 Fax: (408)526-2410
- Wixom (Detroit)  
Tel: (248)347-2607 Fax: (248)347-2602

**Toshiba Electronics do Brasil Ltda.**

Tel: (011)2539-6681 Fax: (011)2539-6675

**Toshiba India Private Ltd.**

Tel: (011)2331-8422 Fax: (011)2371-4603

**Toshiba Electronics Europe GmbH**

- Düsseldorf Head Office  
Tel: (0211)5296-0 Fax: (0211)5296-400
- France Branch  
Tel: (1)47282828 Fax: (1)42046491
- Italy Branch  
Tel: (039)68701 Fax: (039)6870205
- Spain Branch  
Tel: (91)660-6798 Fax: (91)660-6799
- U.K. Branch  
Tel: (1252)5300 Fax: (1252)53-0250
- Sweden Branch  
Tel: (8)704-0900 Fax: (8)80-8459

**Toshiba Electronics Asia (Singapore) Pte. Ltd.**

Tel: (6278)5252 Fax: (6271)5155

**Toshiba Electronics Service (Thailand) Co., Ltd.**

Tel: (02)501-1635 Fax: (02)501-1638

**Toshiba Electronics Trading (Malaysia) Sdn. Bhd.**

- Kuala Lumpur Head Office  
Tel: (03)5631-6311 Fax: (03)5631-6307
- Penang Office  
Tel: (04)226-8523 Fax: (04)226-8515

**Toshiba Electronics Asia, Ltd.**

- Hong Kong Head Office  
Tel: 2375-6111 Fax: 2375-0969
- Beijing Office  
Tel: (010)6590-8796 Fax: (010)6590-8791
- Chengdu Office  
Tel: (028)8675-1773 Fax: (028)8675-1065
- Qingdao Office  
Tel: (532)8579-3328 Fax: (532)8579-3329

**Toshiba Electronics Shenzhen Co., Ltd.**

Tel: (0755)2399-6897 Fax: (0755)2399-5573

**Toshiba Electronics (Shanghai) Co., Ltd.**

- Shanghai Head Office  
Tel: (021)6841-0666 Fax: (021)6841-5002

- Hangzhou Office  
Tel: (0571)8717-5004 Fax: (0571)8717-5013

- Nanjing Office  
Tel: (025)8689-0070 Fax: (025)8689-0125

**Toshiba Electronics (Dalian) Co., Ltd.**

Tel: (0411)8368-6882 Fax: (0411)8369-0822

**Tsurong Xiamen Xiangyu Trading Co., Ltd.**

Tel: (0592)226-1398 Fax: (0592)226-1399

**Toshiba Electronics Korea Corporation**

- Seoul Head Office  
Tel: (02)3484-4334 Fax: (02)3484-4302
- Daegu Office  
Tel: (053)428-7610 Fax: (053)428-7617

**Toshiba Electronics Taiwan Corporation**

- Taipei Head Office  
Tel: (02)2508-9988 Fax: (02)2508-9999
- Kaohsiung Office  
Tel: (07)237-0826 Fax: (07)236-0046

- ▶ Toshiba Corporation, and its subsidiaries and affiliates (collectively "TOSHIBA"), reserve the right to make changes to the information in this document, and related hardware, software and systems (collectively "Product") without notice.
- ▶ This document and any information herein may not be reproduced without prior written permission from TOSHIBA. Even with TOSHIBA's written permission, reproduction is permissible only if reproduction is without alteration/omission.
- ▶ Though TOSHIBA works continually to improve Product's quality and reliability, Product can malfunction or fail. Customers are responsible for complying with safety standards and for providing adequate designs and safeguards for their hardware, software and systems which minimize risk and avoid situations in which a malfunction or failure of Product could cause loss of human life, bodily injury or damage to property, including data loss or corruption. Before customers use the Product, create designs including the Product, or incorporate the Product into their own applications, customers must also refer to and comply with (a) the latest versions of all relevant TOSHIBA information, including without limitation, this document, the specifications, the data sheets and application notes for Product and the precautions and conditions set forth in the "TOSHIBA Semiconductor Reliability Handbook" and (b) the instructions for the application with which the Product will be used with or for. Customers are solely responsible for all aspects of their own product design or applications, including but not limited to (a) determining the appropriateness of the use of this Product in such design or applications; (b) evaluating and determining the applicability of any information contained in this document, or in charts, diagrams, programs, algorithms, sample application circuits, or any other referenced documents; and (c) validating all operating parameters for such designs and applications. **TOSHIBA ASSUMES NO LIABILITY FOR CUSTOMERS' PRODUCT DESIGN OR APPLICATIONS.**
- ▶ Product is intended for use in general electronics applications (e.g., computers, personal equipment, office equipment, measuring equipment, industrial robots and home electronics appliances) or for specific applications as expressly stated in this document. Product is neither intended nor warranted for use in equipment or systems that require extraordinarily high levels of quality and/or reliability and/or a malfunction or failure of which may cause loss of human life, bodily injury, serious property damage or serious public impact ("Unintended Use"). Unintended Use includes, without limitation, equipment used in nuclear facilities, equipment used in the aerospace industry, medical equipment, equipment used for automobiles, trains, ships and other transportation, traffic signaling equipment, equipment used to control combustions or explosions, safety devices, elevators and escalators, devices related to electric power, and equipment used in finance-related fields. Do not use Product for Unintended Use unless specifically permitted in this document.
- ▶ Do not disassemble, analyze, reverse-engineer, alter, modify, translate or copy Product, whether in whole or in part.
- ▶ Product shall not be used for or incorporated into any products or systems whose manufacture, use, or sale is prohibited under any applicable laws or regulations.
- ▶ The information contained herein is presented only as guidance for Product use. No responsibility is assumed by TOSHIBA for any infringement of patents or any other intellectual property rights of third parties that may result from the use of Product. No license to any intellectual property right is granted by this document, whether express or implied, by estoppel or otherwise.
- ▶ **ABSENT A WRITTEN SIGNED AGREEMENT, EXCEPT AS PROVIDED IN THE RELEVANT TERMS AND CONDITIONS OF SALE FOR PRODUCT, AND TO THE MAXIMUM EXTENT ALLOWABLE BY LAW, TOSHIBA (1) ASSUMES NO LIABILITY WHATSOEVER, INCLUDING WITHOUT LIMITATION, INDIRECT, CONSEQUENTIAL, SPECIAL, OR INCIDENTAL DAMAGES OR LOSS, INCLUDING WITHOUT LIMITATION, LOSS OF PROFITS, LOSS OF OPPORTUNITIES, BUSINESS INTERRUPTION AND LOSS OF DATA, AND (2) DISCLAIMS ANY AND ALL EXPRESS OR IMPLIED WARRANTIES AND CONDITIONS RELATED TO SALE, USE OF PRODUCT, OR INFORMATION, INCLUDING WARRANTIES OR CONDITIONS OF MERCHANTABILITY, FITNESS FOR A PARTICULAR PURPOSE, ACCURACY OF INFORMATION, OR NONINFRINGEMENT.**
- ▶ Do not use or otherwise make available Product or related software or technology for any military purposes, including without limitation, for the design, development, use, stockpiling or manufacturing of nuclear, chemical, or biological weapons or missile technology products (mass destruction weapons). Product and related software and technology may be controlled under the Japanese Foreign Exchange and Foreign Trade Law and the U.S. Export Administration Regulations. Export and re-export of Product or related software or technology are strictly prohibited except in compliance with all applicable export laws and regulations.
- ▶ Product may include products subject to foreign exchange and foreign trade control laws.
- ▶ Please contact your TOSHIBA sales representative for details as to environmental matters such as the RoHS compatibility of Product. Please use Product in compliance with all applicable laws and regulations that regulate the inclusion or use of controlled substances, including without limitation, the EU RoHS Directive. TOSHIBA assumes no liability for damages or losses occurring as a result of noncompliance with applicable laws and regulations.

**TOSHIBA****TOSHIBA CORPORATION**  
Semiconductor CompanyWebsite: <http://www.semicon.toshiba.co.jp/eng>

©2010 TOSHIBA CORPORATION

Previous edition: SCE0020C  
2010-3(1k)SO-DQ