

# NHD-240128BZ-NSW-BTW

## Graphic Liquid Crystal Display Module

NHD-	Newhaven Display
240128-	240 x 128 pixels
BZ-	Model
N-	Transmissive
SW-	Side White LED Backlight
B-	STN - Blue (-)
T-	12:00 view
W-	Wide Temperature (-20°C ~ +70°C)

**RoHS Compliant**

**Newhaven Display International, Inc.**

2511 Technology Drive, Suite 101

Elgin IL, 60124

Ph: 847-844-8795

Fax: 847-844-8796

[www.newhavendisplay.com](http://www.newhavendisplay.com)

[nhtech@newhavendisplay.com](mailto:nhtech@newhavendisplay.com)

[nhsales@newhavendisplay.com](mailto:nhsales@newhavendisplay.com)

## Document Revision History

Revision	Date	Description	Changed by
0	10/5/2007	Initial Release	-
1	6/4/2008	Update table of contents	CL
2	4/22/2010	User guide reformat	BE
3	9/20/2010	Pin description pin18/electrical characteristics updated	BE
4	11/30/2010	Update Mechanical Drawing / Block Diagram	AK

## Functions and Features

- 240 x 128 pixels
- Built-in RA8835 controller
- +5.0V Power Supply
- 1/128 duty, 1/12 bias
- RoHS Compliant

# Mechanical Drawing

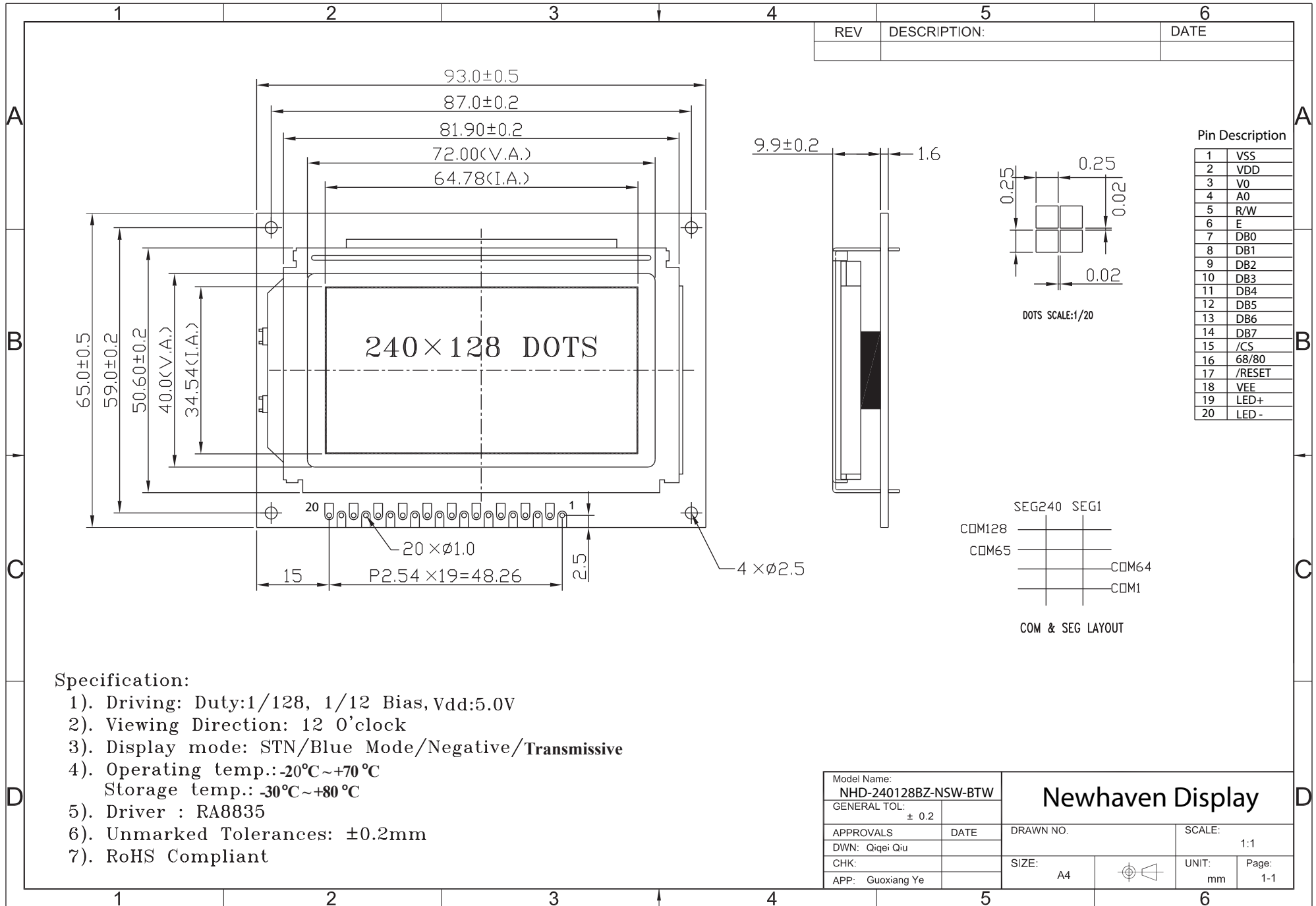

## Pin Description and Wiring Diagram

Pin No.	Symbol	External Connection	Function Description
1	VSS	Power Supply	Ground
2	VDD	Power Supply	Power supply for logic (+5.0V)
3	V0	Adj. Power Supply	Power Supply for contrast (approx – 13.5V)
4	A0	MPU	Register Select signal. 0: instruction; 1: data
5	R/W	MPU	Read/Write select signal, R/W=1: Read R/W=0: Write
6	E	MPU	Operation enable signal. Falling edge triggered.
7-10	DB0-DB3	MPU	Four low order bi-directional three-state data bus lines. These four are not used during 4-bit operation.
11-14	DB4-DB7	MPU	Four high order bi-directional three-state data bus lines.
15	/CS	MPU	Active LOW Chip Select Signal
16	68/80	MPU	Interface Select Pin. 0: 8080 Family 1: 6800 Family
17	/RESET	MPU	Active LOW reset signal
18	VEE	Power Supply	Positive voltage supply output (+20V)
19	LED+	Power Supply	Power supply for LED Backlight (+3.0V)
20	LED-	Power Supply	Ground for Backlight

**Recommended LCD connector:** 2.54mm pitch pins

**Backlight connector:** -      **Mates with:** -

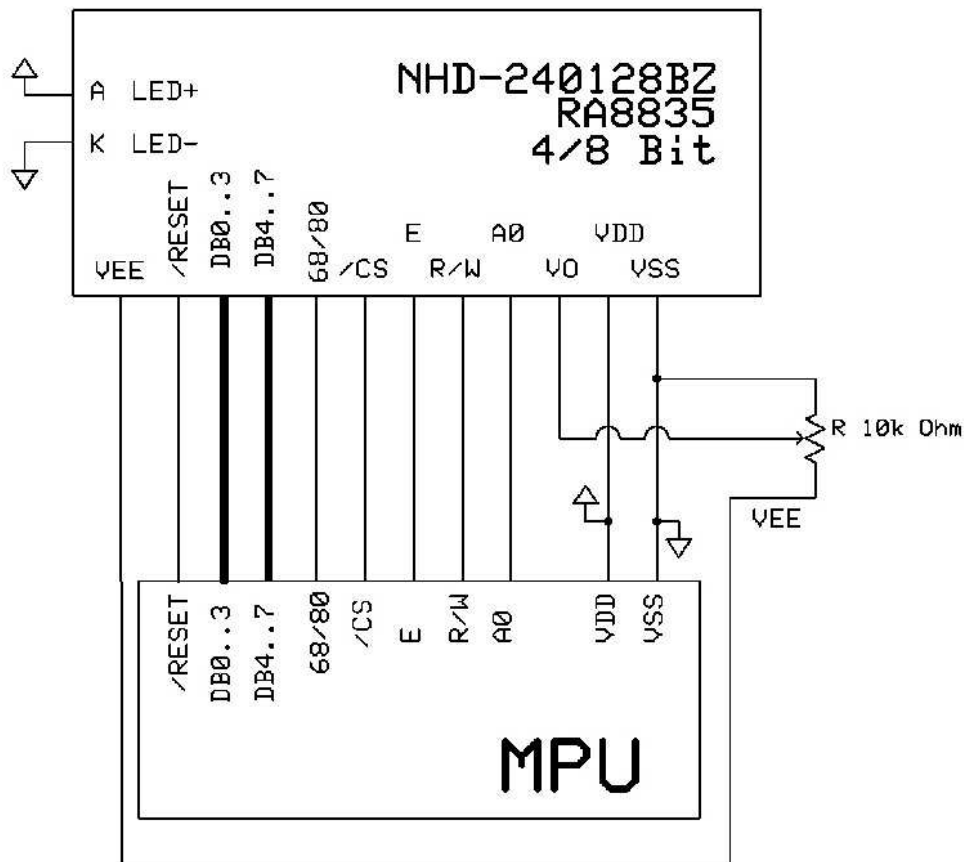

## Electrical Characteristics

Item	Symbol	Condition	Min.	Typ.	Max.	Unit
Operating Temperature Range	Top	Absolute Max	-20	-	+70	°C
Storage Temperature Range	Tst	Absolute Max	-30	-	+80	°C
Supply Voltage	VDD		4.7	5.0	5.5	V
Supply Current	IDD	VDD=5.0V	-	3.5	5.5	mA
Supply for LCD (contrast)	VDD-V0	Ta=25°	-	-13.5	-	V
"H" Level input	VIH		2.2	-	VDD	V
"L" Level input	VIL		0	-	0.6	V
"H" Level output	VOH		2.4	-	-	V
"L" Level output	VOL		-	-	0.4	V
Backlight Supply Voltage	Vled	-	-	3.0	-	V
Backlight Supply Current	Iled	Vled=3.0V	-	36	-	mA

## Optical Characteristics

Item	Symbol	Condition	Min.	Typ.	Max.	Unit
Viewing Angle - Vertical	AV	Cr ≥ 2	-	60	-	°
Viewing Angle - Vertical	AV	Cr ≥ 2	-	35	-	°
Viewing Angle – Horizontal	AH	Cr ≥ 2	-	40	-	°
Viewing Angle - Horizontal	AH	Cr ≥ 2	-	40	-	°
Contrast Ratio	Cr		-	6	-	-
Response Time (rise)	Tr	-	-	150	250	ms
Response Time (fall)	Tf	-	-	150	250	ms

## Controller Information

Built-in RA8835. Download specification at [http://www.newhavendisplay.com/app\\_notes/RA8835.pdf](http://www.newhavendisplay.com/app_notes/RA8835.pdf)

## Table of Commands

Class	Command	Code											Hex	Command Description	Command Read Parameters	
		RD	WR	A0	D7	D6	D5	D4	D3	D2	D1	D0			No. of Bytes	Section
System Control	<b>SYSTEM SET</b>	1	0	1	0	1	0	0	0	0	0	0	40	Initialize device and display	8	9-2-1
	<b>SLEEP IN</b>	1	0	1	0	1	0	1	0	0	1	1	53	Enter standby mode	0	9-2-2
Display Control	<b>DISPLAY ON/OFF</b>	1	0	1	0	1	0	1	1	0	0	D	58, 59	Enable and disable display and display flashing	1	9-3-1
	<b>SCROLL</b>	1	0	1	0	1	0	0	0	1	0	0	44	Set display start address and display regions	10	9-3-2
	<b>CSRFORM</b>	1	0	1	0	1	0	1	1	1	0	1	5D	Set cursor type	2	9-3-3
	<b>CGRAM ADR</b>	1	0	1	0	1	0	1	1	1	0	0	5C	Set start address of character generator RAM	2	9-3-6
	<b>CSRDIR</b>	1	0	1	0	1	0	0	1	1	CD 1	CD 0	4C to 4F	Set direction of cursor movement	0	9-3-4
	<b>HDOT SCR</b>	1	0	1	0	1	0	1	1	0	1	0	5A	Set horizontal scroll position	1	9-3-7
	<b>OVLAY</b>	1	0	1	0	1	0	1	1	0	1	1	5B	Set display overlay format	1	9-3-5
Drawing Control	<b>CSRW</b>	1	0	1	0	1	0	0	0	1	1	0	46	Set cursor address	2	9-r1
	<b>CSRR</b>	1	0	1	0	1	0	0	0	1	1	1	47	Read cursor address	2	9-4-2
Memory Control	<b>MWRITE</b>	1	0	1	0	1	0	0	0	0	1	0	42	Write to display memory	—	9-5-1
	<b>MREAD</b>	1	0	1	0	1	0	0	0	0	1	1	43	Read from display memory	—	9-5-2

# Timing Characteristics

## 10-3-1 8080 Family Interface Timing

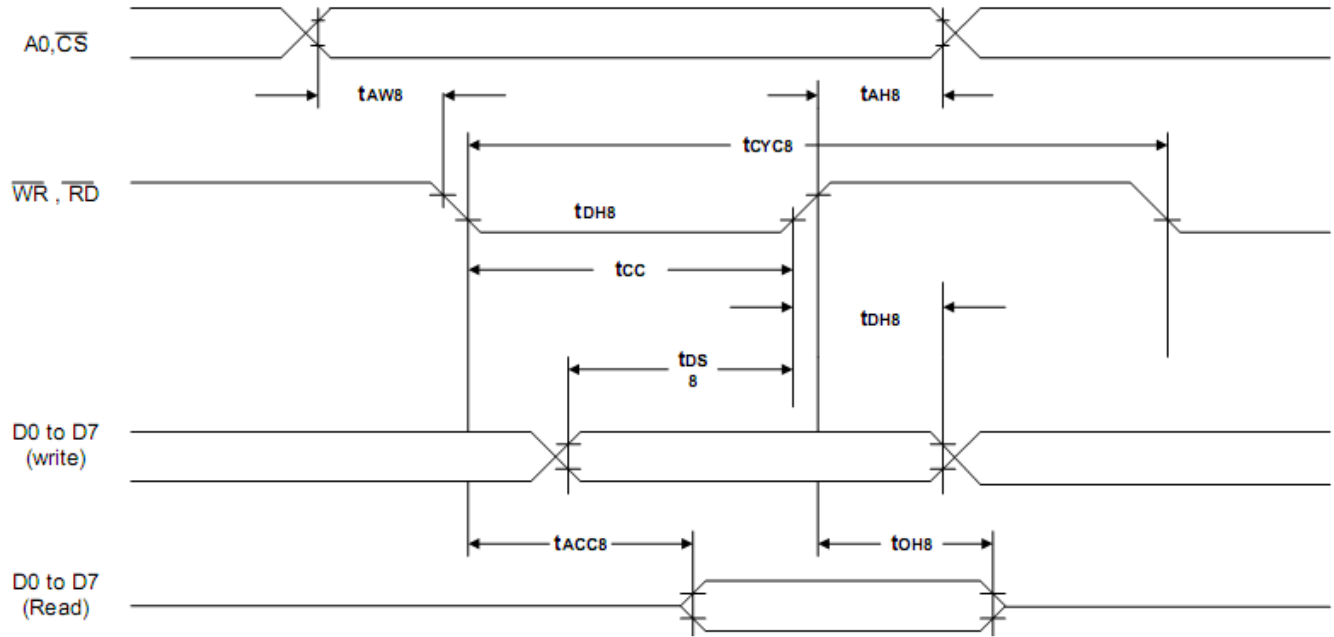

T<sub>a</sub> = -20 to 75°C

Signal	Symbol	Parameter	V <sub>DD</sub> = 4.5 to 5.5V		V <sub>DD</sub> = 2.7 to 4.5V		Unit	Condition
			Min.	Max.	Min.	Max.		
A0, $\overline{CS}$	t <sub>AH8</sub>	Address hold time	10	—	10	—	ns	CL = 100pF
	t <sub>AW8</sub>	Address setup time	0	—	0	—	ns	
$\overline{WR}$ , $\overline{RD}$	t <sub>CYC8</sub>	System cycle time	note.	—	note.	—	ns	
	t <sub>CC</sub>	Strobe pulse width	120	—	150	—	ns	
D0 to D7	t <sub>DS8</sub>	Data setup time	120	—	120	—	ns	
	t <sub>DH8</sub>	Data hold time	5	—	5	—	ns	
	t <sub>ACC8</sub>	$\overline{RD}$ access time	—	50	—	80	ns	
	t <sub>OH8</sub>	Output disable time	10	50	10	55	ns	

## 6800 Family Interface Timing

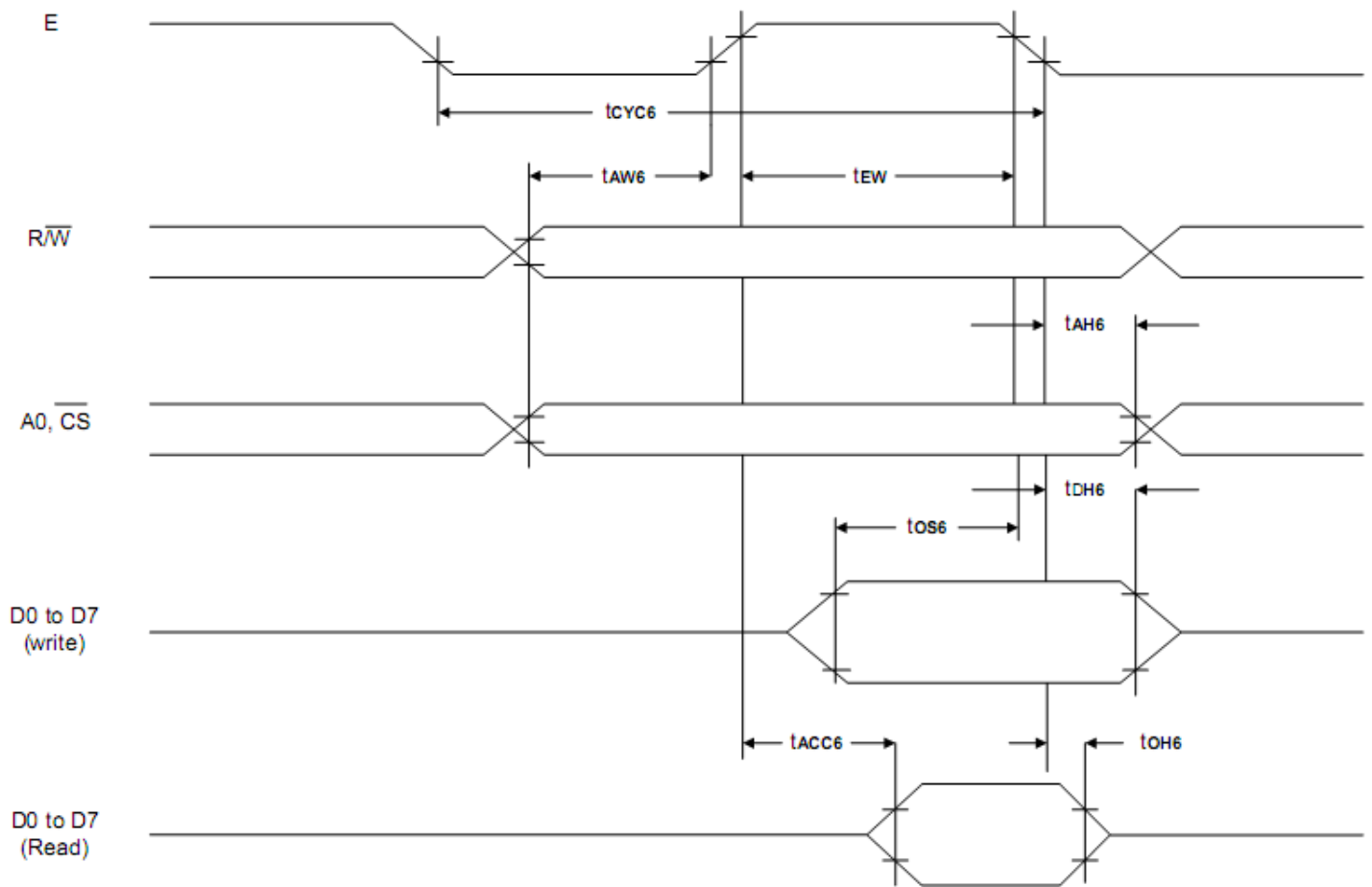

$T_a = -20$  to  $75^\circ\text{C}$

Signal	Symbol	Parameter	$V_{DD} = 4.5$ to $5.5\text{V}$		$V_{DD} = 2.7$ to $4.5\text{V}$		Unit	Condition
			Min.	Max.	Min.	Max.		
A0, $\overline{\text{CS}}$ , R/(W)	$t_{CYC6}$	System cycle time	note.	—	note.	—	ns	CL = 100 pF
	$t_{AW6}$	Address setup time	0	—	10	—	ns	
	$t_{AH6}$	Address hold time	0	—	0	—	ns	
D0 to D7	$t_{DS6}$	Data setup time	100	—	120	—	ns	
	$t_{DH6}$	Data hold time	0	—	0	—	ns	
	$t_{OH6}$	Output disable time	10	50	10	75	ns	
	$t_{ACC6}$	Access time	—	85	—	130	ns	
E	$t_{EW}$	Enable pulse width	120	—	150	—	ns	



## Display Memory Read Timing

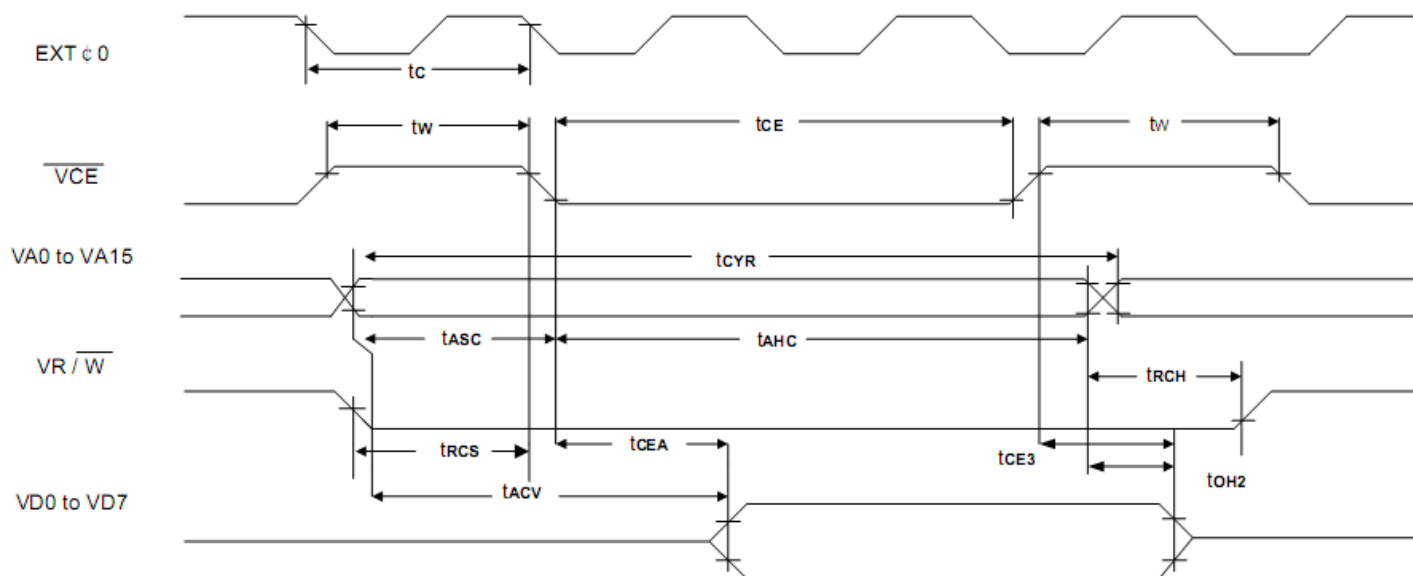

Ta = -20 to 75°C

Signal	Symbol	Parameter	V <sub>DD</sub> = 4.5 to 5.5V		V <sub>DD</sub> = 2.7 to 4.5V		Unit	Condition
			Min.	Max.	Min.	Max.		
EXT Φ0	t <sub>c</sub>	Clock period	100	—	125	—	ns	CL = 100 pF
$\overline{\text{VCE}}$	t <sub>w</sub>	VCE HIGH-level pulse width	t <sub>c</sub> - 50	—	t <sub>c</sub> - 50	—	ns	
	t <sub>CE</sub>	VCE LOW-level pulse width	2t <sub>c</sub> - 30	—	2t <sub>c</sub> - 30	—	ns	
VA0 to VA15	t <sub>CYR</sub>	Read cycle time	3t <sub>c</sub>	—	3t <sub>c</sub>	—	ns	
	t <sub>ASC</sub>	Address setup time to falling edge of $\overline{\text{VCE}}$	t <sub>c</sub> - 70	—	t <sub>c</sub> - 100	—	ns	
	t <sub>AHC</sub>	Address hold time from falling edge of $\overline{\text{VCE}}$	2t <sub>c</sub> - 30	—	2t <sub>c</sub> - 40	—	ns	
$\overline{\text{VRD}}$	t <sub>RCS</sub>	Read cycle setup time to falling edge of $\overline{\text{VCE}}$	t <sub>c</sub> - 45	—	t <sub>c</sub> - 60	—	ns	
	t <sub>RCH</sub>	Read cycle hold time from rising edge of $\overline{\text{VCE}}$	0.5t <sub>c</sub>	—	0.5t <sub>c</sub>	—	ns	
VD0 to VD7	t <sub>ACV</sub>	Address access time	—	3t <sub>c</sub> - 100	—	3t <sub>c</sub> - 115	Ns	
	t <sub>CEA</sub>	VCE access time	—	2t <sub>c</sub> - 80	—	2t <sub>c</sub> - 90	Ns	
	t <sub>OH2</sub>	Output data hold time	0	—	0	—	ns	
	t <sub>CE3</sub>	VCE to data off time	0	—	0	—	ns	



## Example Initialization Program

```
//-----  
sbit A0 = P3^0;  
sbit RW = P3^7;  
sbit E = P3^4;  
sbit CS = P3^1;  
sbit IM = P3^6;  
sbit RST = P3^2;  
  
//-----  
void Writecom(int A)  
{  
    CS = 0;  
    RW = 0;  
    A0 = 1;  
    E = 1;  
    P1 = A;  
    E = 1;  
}  
  
void Write(int A)  
{  
    CS = 0;  
    RW = 0;  
    A0 = 0;  
    E = 1;  
    P1 = A;  
    E = 1;  
}  
  
//-----  
void init()  
{  
    IM = 1;  
    RST = 0;  
    delay(10);  
    RST = 1;  
    delay(100);  
    Writecom(0x40);  
    Write(0x30);  
    Write(0x87);  
    Write(0x07);  
    Write(0x1D);  
    Write(0x50);  
    Write(0x80);  
    Write(0x1E);  
    Write(0x00);  
    Writecom(0x44);  
    Write(0x00);  
    Write(0x00);  
    Write(0x80);  
    Write(0x00);  
    Write(0x40);  
    Write(0x80);  
    Write(0x00);  
    Write(0x00);  
    Write(0x00);  
    Write(0x00);  
    Write(0x5A);  
    Write(0x00);  
    Write(0x5B);  
    Write(0x0C);  
    Write(0x4C);  
    Write(0x46);  
}
```

```
Write(0xB0);
Write(0xB0);
Write(0x42);
Write(0x00);

for(a = 0; a < 3840; a++)
{
    Write(0x00);
}
Writecom(0x46);
Write(0x60);
Write(0x09);
Writecom(0x42);
Write(0x00);
for(a = 0; a < 3840; a++)
{
    Write(0x00);
}
Writecom(0x59);
Write(0x04);
}
//-----
```

## Quality Information

Test Item	Content of Test	Test Condition	Note
High Temperature storage	Endurance test applying the high storage temperature for a long time.	+80°C , 200hrs	2
Low Temperature storage	Endurance test applying the low storage temperature for a long time.	-30°C , 200hrs	1,2
High Temperature Operation	Endurance test applying the electric stress (voltage & current) and the high thermal stress for a long time.	+70°C 200hrs	2
Low Temperature Operation	Endurance test applying the electric stress (voltage & current) and the low thermal stress for a long time.	-20°C , 200hrs	1,2
High Temperature / Humidity Operation	Endurance test applying the electric stress (voltage & current) and the high thermal with high humidity stress for a long time.	+60°C , 90% RH , 96hrs	1,2
Thermal Shock resistance	Endurance test applying the electric stress (voltage & current) during a cycle of low and high thermal stress.	-20°C,30min -> 25°C,5min -> 70°C,30min = 1 cycle 10 cycles	
Vibration test	Endurance test applying vibration to simulate transportation and use.	10-55Hz , 15mm amplitude. 60 sec in each of 3 directions X,Y,Z For 15 minutes	3
Static electricity test	Endurance test applying electric static discharge.	VS=800V, RS=1.5kΩ, CS=100pF One time	

**Note 1:** No condensation to be observed.

**Note 2:** Conducted after 4 hours of storage at 25°C, 0%RH.

**Note 3:** Test performed on product itself, not inside a container.

## Precautions for using LCDs/LCMs

See Precautions at [www.newhavendisplay.com/specs/precautions.pdf](http://www.newhavendisplay.com/specs/precautions.pdf)

## Warranty Information and Terms & Conditions

[http://www.newhavendisplay.com/index.php?main\\_page=terms](http://www.newhavendisplay.com/index.php?main_page=terms)