

10 9 8 7 6 70021 4 3

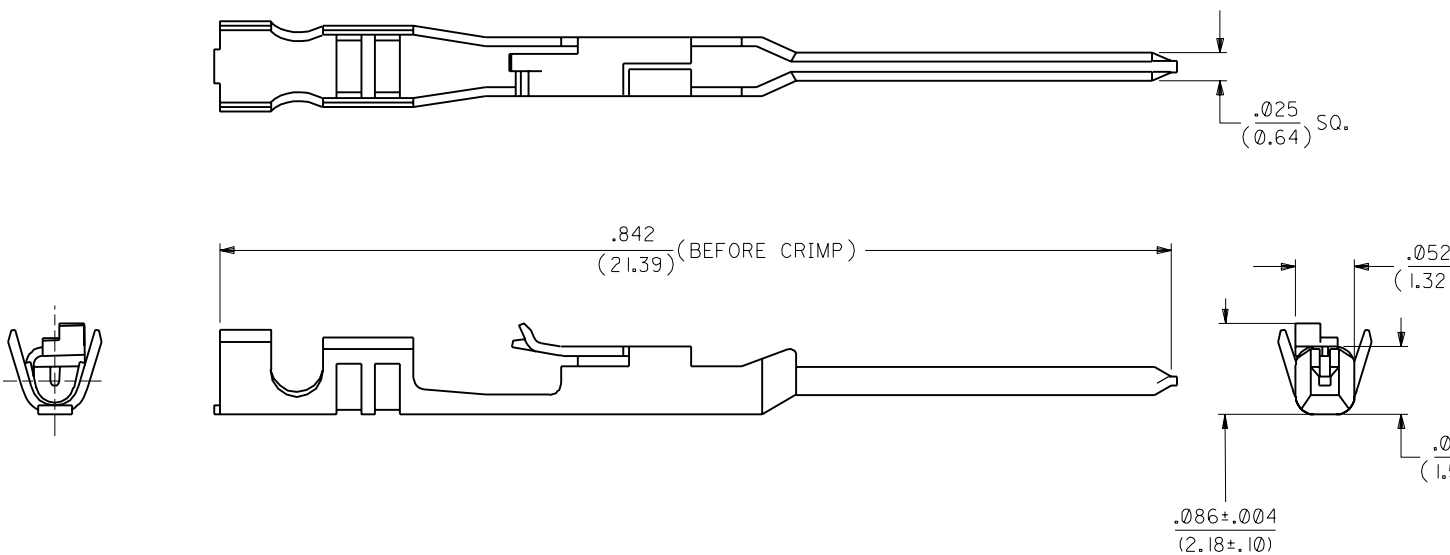

NOTES:

1. TERMINAL FOR USE WITH HOUSING PART NO. 70066-**** & 70107-****.
2. MATERIAL: .008/(0.20) THK. PHOSPHOR BRONZE.
3. TERMINAL TO BE USED WITH 22-24 AWG STRANDED WIRE WITH .064 DIA. MAX. INSULATION.
4. REFER TO MOLEX OPERATIONAL AND SERVICE MANUAL FOR DETAILS.
5. REFER TO PRODUCT SPECIFICATION NO. PS-70021.
6. PARTS SUPPLIED IN REEL FORM.

PLATING:

.000150 MIN. TIN/LEAD PLATE OVER NICKEL PLATE.

DIMENSIONS SHOWN (METRIC) INCH		▽ = 0	▼ = 0
UNLESS OTHERWISE SPECIFIED TOLERANCES: ANGULAR ± 1/2°			
	INCH	METRIC	
3 PLACE	± .010	---	
2 PLACE	± .015	± 0.25	
1 PLACE	---	± 0.35	
DRAFT WHERE APPLICABLE MUST REMAIN WITHIN DIMENSIONS			
DRWG. BY: WJF	CHK'D. BY: MJM	FILE NAME: ST0021X21.DGN	
APP'D. BY: WAZ	SCALE: 10: 1	THIS DRAWING C MOLEX INC. AND SH	

TITLE: TERMINAL

PART NO. 16-02-0107

MOLEX INCORPORATED LISLE, ILL. 60532

10 9 8 7 6 5 4 3