

**12-CHARACTER 4-LINE
DOT MATRIX LCD CONTROLLER****■ GENERAL DESCRIPTION**

The NJU6620 is a Dot Matrix LCD controller driver for 12-character 4-line with icon display in single chip.

It contains voltage converter and regulator, bleeder resistance, CR oscillator, microprocessor interface circuits, instruction decoder controller, character generator ROM/RAM, high voltage operation common and segment drivers.

The voltage converter generates high voltage (about 8V) from the supply voltage (3V) and it is regulated by the regulator. The bias level of LCD driving voltage is generated of high value of bleeder resistance and the buffer amplifier convert its impedance. The 16th gray scale contrast control function is incorporated for its adjustment. Therefore, simple power supply circuit and easy contrast adjustment are available. The complete CR oscillator is incorporated, therefore no external components for oscillation circuit are required. The microprocessor interface circuits which operate by 1MHz, can be selected serial, 4 or 8 bit interface.

The character generator ROM consists of 10,080 bits stores 252 kinds of character Font. Each 160 bits CG RAM and Icon display RAM can stores 4 kinds of special character displayed on the dot matrix display area or 152 kind of Icon on the Icon display area.

The 37-common (32 for character, 4 for icon and 1 for static) and 63-segment (60 for character, 2 for icon and 1 for static) drivers operated up to 9.9V drives 12-character 4-line with 128 Icon and static segment LCD display.

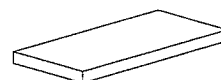
■ PACKAGE OUTLINE**NJU6620CH****■ FEATURES**

- 12-character 4-line Dot Matrix LCD Controller Driver
- Maximum 128 Icon Display
- Serial, 4 or 8 Bit parallel Direct Interface with Microprocessor
- Display Data RAM - 48 x 8 bits : Maximum 12-character 4-line Display
- Character Generator ROM - 10,080 bits : 252 Characters for 5 x 7 Dots
- Character Generator RAM - 32 x 5 bits : 4 Patterns (5 x 7 Dots)
- Icon Display RAM - 32 x 5 bits : Maximum 128 Icon
- High Voltage LCD Driver : 37-common / 63-segment
- Duty and Bias Ratio : 1/36 duty and 1/7 bias
- Useful Instruction Set : Clear Display, Return Home, Display ON/OFF Cont, Cursor ON/OFF Cont, Display Blink, Cursor Shift, Character Shift
- Common and Segment driver Location order Select Function (Mode A/Mode B)
- Power On Initialization / Hardware Reset
- Voltage Converter and Bleeder Resistance on-chip
- Voltage regulator on-chip
- Software contrast control
- Oscillation Circuit on-chip
- Low Power Consumption
- Operating Voltage --- 2.4 to 3.3 V (Except LCD Driving Voltage)
- Package Outline --- Bumped Chip
- C-MOS Technology

Feb. 1999

Ver. 1

■ PAD LOCATION

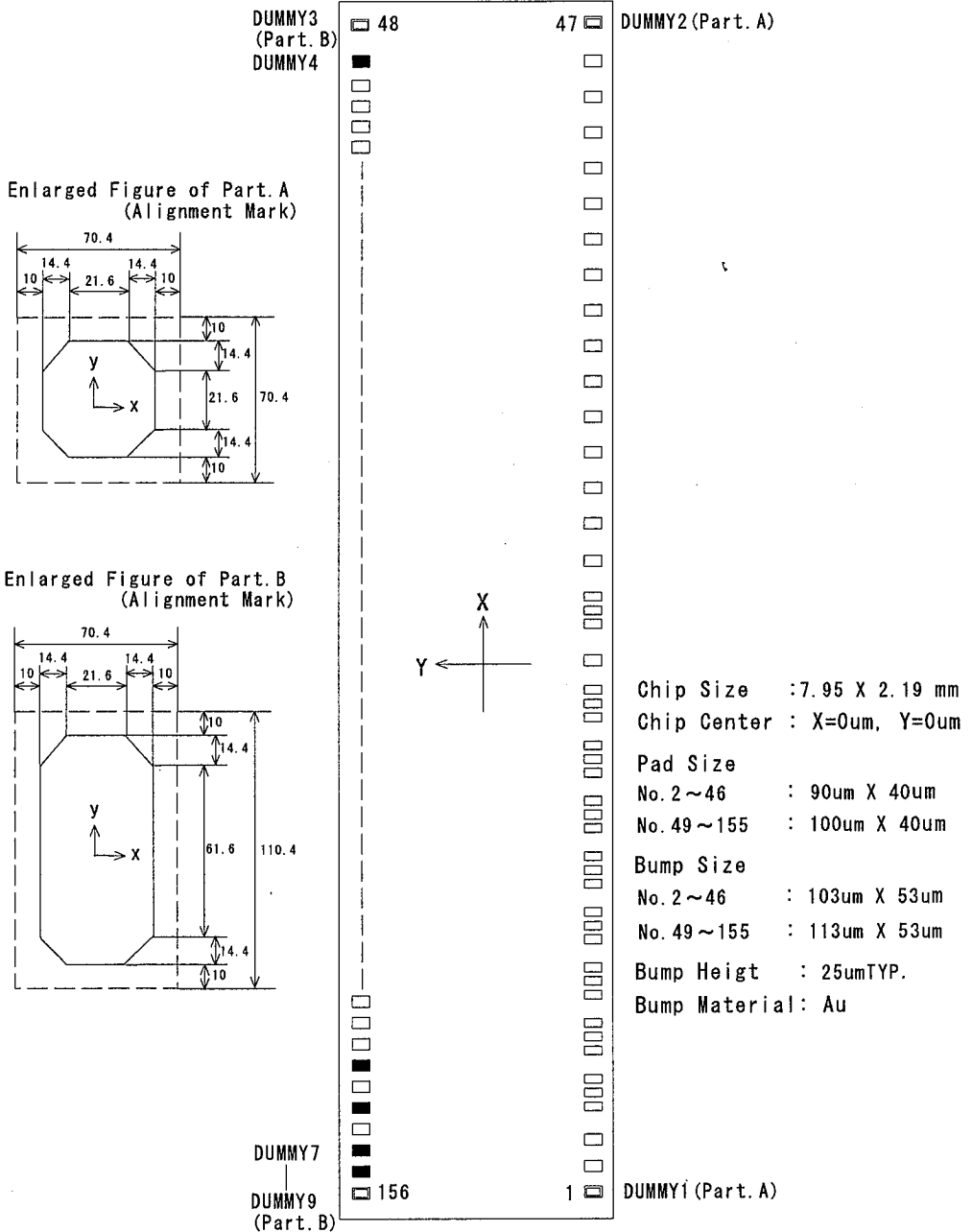



NJU6620

■ PAD COORDINATES CHIP

SIZE 7.95 mm x 2.19 mm (CHIP CENTER X=0 μ m, Y=0 μ m)

PAD No.	PAD NAME		X= (μ m)	Y= (μ m)
	Mode A	Mode B		
1	DUMMY1	DUMMY1	-3831	-935
2	OSC1	OSC1	-3570	-935
3	OSC2	OSC2	-3405	-935
4	V5	V5	-3252	-935
5	V5	V5	-3180	-935
6	V5	V5	-3107	-935
7	VSS	VSS	-2865	-935
8	VSS	VSS	-2793	-935
9	VSS	VSS	-2720	-935
10	V5OUT	V5OUT	-2568	-935
11	V5OUT	V5OUT	-2495	-935
12	V5OUT	V5OUT	-2423	-935
13	C2-	C2-	-2178	-935
14	C2-	C2-	-2105	-935
15	C2-	C2-	-2033	-935
16	C2'	C2'	-1791	-935
17	C2'	C2'	-1718	-935
18	C2'	C2'	-1646	-935
19	C1-	C1-	-1404	-935
20	C1-	C1-	-1332	-935
21	C1-	C1-	-1259	-935
22	C1+	C1+	-1017	-935
23	C1+	C1+	-945	-935
24	C1+	C1+	-872	-935
25	VDD	VDD	-719	-935
26	VDD	VDD	-646	-935
27	VDD	VDD	-574	-935
28	VR	VR	-423	-935
29	VREG	VREG	-10	-935
30	VREG	VREG	62	-935
31	VREG	VREG	135	-935
32	TEST	TEST	324	-935
33	SEL	SEL	666	-935
34	RESET	RESET	841	-935
35	P/S	P/S	1131	-935
36	RS	RS	1299	-935
37	R/W	R/W	1590	-935
38	E/SCL	E/SCL	1758	-935
39	DB0	DB0	2031	-935
40	DB1	DB1	2255	-935
41	DB2	DB2	2497	-935
42	DB3	DB3	2722	-935
43	DB4	DB4	2964	-935
44	DB5	DB5	3189	-935
45	DB6	DB6	3430	-935
46	DB7	DB7	3655	-935
47	DUMMY2	DUMMY2	3831	-935
48	DUMMY3	DUMMY3	3785	940
49	DUMMY4	DUMMY4	3710	940
50	SEGS1	SEGS1	3640	940

PAD No.	PAD NAME		X= (μ m)	Y= (μ m)
	Mode A	Mode B		
51	COM9	COM9	3570	940
52	COM10	COM10	3500	940
53	COM11	COM11	3430	940
54	COM12	COM12	3360	940
55	COM13	COM13	3290	940
56	COM14	COM14	3220	940
57	COM15	COM15	3150	940
58	COM16	COM16	3080	940
59	COM25	COM25	3010	940
60	COM26	COM26	2940	940
61	COM27	COM27	2870	940
62	COM28	COM28	2800	940
63	COM29	COM29	2730	940
64	COM30	COM30	2660	940
65	COM31	COM31	2590	940
66	COM32	COM32	2520	940
67	SEG1	SEG2	2450	940
68	SEG1	SEG60	2380	940
69	SEG2	SEG59	2310	940
70	SEG3	SEG58	2240	940
71	SEG4	SEG57	2170	940
72	SEG5	SEG56	2100	940
73	SEG6	SEG55	2030	940
74	SEG7	SEG54	1960	940
75	SEG8	SEG53	1890	940
76	SEG9	SEG52	1820	940
77	SEG10	SEG51	1750	940
78	SEG11	SEG50	1680	940
79	SEG12	SEG49	1610	940
80	SEG13	SEG48	1540	940
81	SEG14	SEG47	1470	940
82	SEG15	SEG46	1400	940
83	SEG16	SEG45	1330	940
84	SEG17	SEG44	1260	940
85	SEG18	SEG43	1190	940
86	SEG19	SEG42	1120	940
87	SEG20	SEG41	1050	940
88	SEG21	SEG40	980	940
89	SEG22	SEG39	910	940
90	SEG23	SEG38	840	940
91	SEG24	SEG37	770	940
92	SEG25	SEG36	700	940
93	SEG26	SEG35	630	940
94	SEG27	SEG34	560	940
95	SEG28	SEG33	490	940
96	SEG29	SEG32	420	940
97	SEG30	SEG31	350	940
98	SEG31	SEG30	280	940
99	SEG32	SEG29	210	940
100	SEG33	SEG28	140	940

New Japan Radio Co., Ltd.

PAD No.	PAD NAME		X= (μm)	Y= (μm)
	Mode A	Mode B		
101	SEG34	SEG27	70	940
102	SEG35	SEG26	0	940
103	SEG36	SEG25	-70	940
104	SEG37	SEG24	-140	940
105	SEG38	SEG23	-210	940
106	SEG39	SEG22	-280	940
107	SEG40	SEG21	-350	940
108	SEG41	SEG20	-420	940
109	SEG42	SEG19	-490	940
110	SEG43	SEG18	-560	940
111	SEG44	SEG17	-630	940
112	SEG45	SEG16	-700	940
113	SEG46	SEG15	-770	940
114	SEG47	SEG14	-840	940
115	SEG48	SEG13	-910	940
116	SEG49	SEG12	-980	940
117	SEG50	SEG11	-1050	940
118	SEG51	SEG10	-1120	940
119	SEG52	SEG9	-1190	940
120	SEG53	SEG8	-1260	940
121	SEG54	SEG7	-1330	940
122	SEG55	SEG6	-1400	940
123	SEG56	SEG5	-1470	940
124	SEG57	SEG4	-1540	940
125	SEG58	SEG3	-1610	940
126	SEG59	SEG2	-1680	940
127	SEG60	SEG1	-1750	940
128	SEGM2	SEGM1	-1820	940
129	COM24	COM24	-1890	940
130	COM23	COM23	-1960	940
131	COM22	COM22	-2030	940
132	COM21	COM21	-2100	940
133	COM20	COM20	-2170	940
134	COM19	COM19	-2240	940
135	COM18	COM18	-2310	940
136	COM17	COM17	-2380	940
137	COM8	COM8	-2450	940
138	COM7	COM7	-2520	940
139	COM6	COM6	-2590	940
140	COM5	COM5	-2660	940
141	COM4	COM4	-2730	940
142	COM3	COM3	-2800	940
143	COM2	COM2	-2870	940
144	COM1	COM1	-2940	940
145	COMM4	COMM4	-3010	940
146	COMM3	COMM3	-3080	940
147	COMM2	COMM2	-3150	940
148	COMM1	COMM1	-3220	940
149	COMS1	COMS1	-3290	940
150	DUMMY5	DUMMY5	-3360	940

PAD No.	PAD NAME		X= (μm)	Y= (μm)
	Mode A	Mode B		
151	CV1V4	CV1V4	-3430	940
152	DUMMY6	DUMMY6	-3500	940
153	CV2V3	CV2V3	-3570	940
154	DUMMY7	DUMMY7	-3640	940
155	DUMMY8	DUMMY8	-3710	940
156	DUMMY9	DUMMY9	-3785	940

Note) Mode A: SEL="L", Mode B: SEL="H"

■ BLOCK DIAGRAM

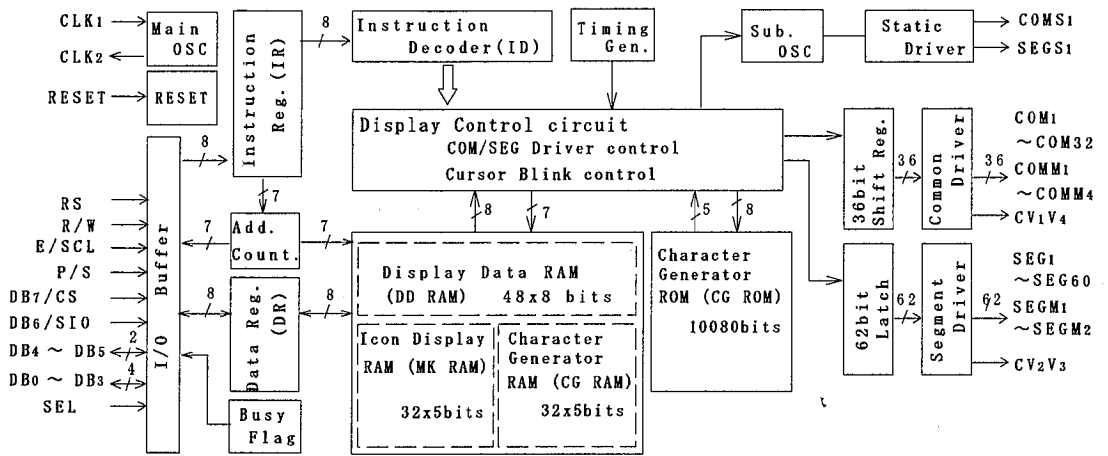

LCD Driving Voltage

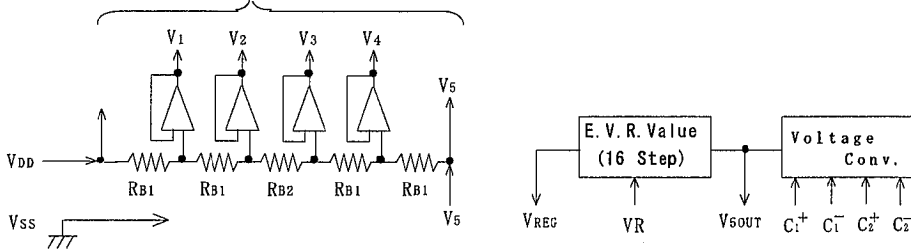

■ TERMINAL DESCRIPTION

PAD No	SYMBOL	I/O	FUNCTION
25~27 7~9	V _{DD} , V _{SS}	—	Power Source VDD: +3V, VSS: 0V
4~6	V _S	—	LCD driving voltage
2	OSC ₁	I	System clock input terminal This terminal should be open, for internal clock operation.
3	OSC ₂	O	System clock output terminal This terminal can use for clock frequency monitoring.。
35	P/S	I	Parallel or serial interface selection terminal "0": Serial interface "1": Parallel interface
36	RS	I	Register selection signal input terminal "0": Instruction register (writing) Busy flag, address counter (reading) "1": Data register (writing / reading)
37	R/W	I	Read / Write selection signal input terminal "0": Write "1": Read
38	E	I	Read / Write activation signal input in parallel mode
	SCL	I	Sift clock input in serial mode
46	DB ₇	I/O	3-state data bus for MSB to transfer the Data between MPU and NJU6620 in parallel mode. DB 7 is also used for the Busy Flag reading.
	CS	I	Chip select signal input in serial mode
45	DB ₆	I/O	3-state data bus for bit 6 to transfer the Data between MPU and NJU6620 in parallel mode
	SIO	I/O	Serial Data I/O in serial mode
43, 44	DB ₅	I/O	3-state data bus for bit 4 and 5 to transfer the Data between MPU and NJU6620 in parallel mode.
39~42	DB ₄	I/O	In serial mode, these terminals are not used and should be open.
39~42	DB ₀ ~DB ₃	I/O	3-state data bus for lower 4 bit to transfer the Data between MPU and NJU6620 in parallel mode In serial and 4-bit parallel mode, these terminals are not used and should be open.
153, 151	CV ₁ V ₄ , CV ₂ V ₃	—	Capacitor terminals for noise reduction of COM/SEG output voltage. The capacitor connected between CV ₁ V ₄ , CV ₂ V ₃ and VDD is required to operate with the LCD panel actually.

PAD No	SYMBOL	I/O	FUNCTION
51~66 129~144	COM ₁ ~COM ₃₂	0	LCD common driving signal output terminals
145~148	COMM ₁ ~COMM ₄	0	Icon common driving signal output terminals
149	COMS ₁	0	Static driving common signal output terminal When power down mode, VDD or VSS level are output.
68~127	SEG ₁ ~SEG ₆₀	0	LCD segment driving signal output terminals
67, 128	SEGM ₁ , SEGM ₂	0	Icon segment driving signal output terminals
50	SEGS ₁	0	Static Driving Segment signal output terminal When power down mode, VDD or VSS level are output.
13~24	C2 ⁻ , C2 ⁺ C1 ⁻ , C1 ⁺	I/O	Step up voltage capacitor connecting terminals In case of tripler operation, connect the capacitor between C1 ⁺ and C1 ⁻ , C2 ⁺ and C2 ⁻ . In case of doubler operation, connect the capacitor between C2 ⁺ and C2 ⁻ , connect C2 ⁺ to C1 ⁺ , and C1 ⁻ should be open.
10~12	V _{500T}	0	Step up voltage output terminal
29~31	V _{REG}	0	Voltage regulator output terminal Connect the resistor between this terminal and VR Terminal.
28	VR	I	Reference voltage for voltage regulator input terminal Connect the resistor between this terminal and VDD terminal.
34	RESET	I	Reset Terminal. When the "L" level input over than 1.2ms to this terminal, the system will be reset (at fOSC=212KHz).
33	SEL	I	Common and Segment driver location order select terminal "0": Mode A location (See the PAD COORDINATES) "1": Mode B location (See the PAD COORDINATES)
32	TEST	I	Maker Testing Terminal (Pull down) This terminal should be connected to VSS or open.
49, 150 152, 154 155, 156	DUMMY ₄ ~DUMMY ₈	—	Dummy terminal These terminals are electrically open.
1, 47 48, 156	DUMMY ₁ DUMMY ₂ DUMMY ₃ DUMMY ₉	—	Dummy terminal These terminals are electrically open and an alignment pattern is placed beside each terminals.

■ FUNCTIONAL DESCRIPTION

(1) Description for each block

(1-1) Register

The NJU6620 incorporates two 8-bit registers, an Instruction Register (IR) and a Data Register (DR). The Register (IR) stores instruction codes such as "Clear Display" and "Cursor Shift" or address data for Display Data RAM (DD RAM), Character Generator RAM (CG RAM) and Icon Display RAM (MK RAM).

The MPU can write the instruction code and address data to the Register (IR), but it cannot read out from the Register (IR).

The Register (DR) is a temporary stored register, the data stored in the Register (DR) is written into the DD RAM, CG RAM or MK RAM and read out from the DD RAM, CG RAM or MK RAM.

The data in the Register (DR) written by the MPU is transferred automatically to the DD RAM, CG RAM or MK RAM by internal operation.

When the address data for the DD RAM, CG RAM or MK RAM is written into the Register (IR), the addressed data in the DD RAM, CG RAM or MK RAM is transferred to the Register (DR).

By the MPU read out the data in the Register (DR), the data transmitting process is performed completely.

After reading the data in the Register (DR) by the MPU, the next address data in the DD RAM, CG RAM or MK RAM is transferred automatically to the Register (DR) to provide for the next MPU reading.

These two registers are selected by the selection signal RS as shown below.

Table 1. shows register operation controlled by RS and R/W signals.

Table 1. Register Operation

RS	R/W	Selected Register	Operation
0	0	IR	Write
0	1		Read busy flag (DB7) and address counter (DB0~DB6)
1	0	DR	Write (Register (DR) to DD RAM, CG RAM or MK RAM)
1	1		Read (DD RAM, CG RAM or MK RAM to Register (DR))

(1-2) Busy Flag (BF)

When the internal circuits are in the operation mode, the busy flag (BF) is "1", and any instruction reading is inhibited.

The busy flag (BF) is output at DB7 when RS="0" and R/W="1" as shown in Table 1.

The next instruction should be written after the busy flag (BF) goes to "0".

(1-3) Address Counter (AC)

The address counter (AC) addresses the DD RAM, CG RAM or MK RAM.

When the address setting instruction is written into the Register (IR), the address information is transferred from Register (IR) to the Counter (AC). The selection of either the DD RAM, CG RAM or MK RAM is also determined by this instruction.

After writing (or reading) the display data to (or from) the DD RAM, CG RAM or MK RAM, the Counter (AC) increments (or decrements) automatically.

The address data in the Counter (AC) is output from DB6 ~ DB0 when RS="0" and R/W="1" as shown in Table 1.

(1-4) Display Data RAM (DD RAM)

The display data RAM (DD RAM) consists of 48 x 8 bits stores up to 48-character display data represented in 8-bit code.

The DD RAM address data set in the address counter (AC) is represented in Hexadecimal.

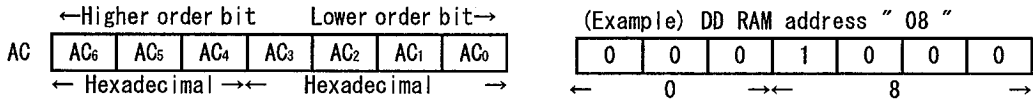

4-line Display

The relation between DD RAM address and display position on the LCD is shown below.

	1	2	3	4	5	6	7	8	9	10	11	12	←Display Position
1st Line	00	01	02	03	04	05	06	07	08	09	0A	0B	←DD RAM Address (Hexadecimal)
2nd Line	10	11	12	13	14	15	16	17	18	19	1A	1B	
3rd Line	20	21	22	23	24	25	26	27	28	29	2A	2B	
4th Line	30	31	32	33	34	35	36	37	38	39	3A	3B	

Note : The 1st, 2nd, 3rd and 4th line address are defined as (00)H to (0B)H, (10)H to (1B)H, (20)H to (2B)H, and (30)H to (3B)H. The end of each line address and the beginning of following line address are not consecutive.

When the display shift is performed, the DD RAM address changes as follows:

(Left Shift Display)

(00) ←	01	02	03	04	05	06	07	08	09	0A	0B	00
(10) ←	11	12	13	14	15	16	17	18	19	1A	1B	10
(20) ←	21	22	23	24	25	26	27	28	29	2A	2B	20
(30) ←	31	32	33	34	35	36	37	38	39	3A	3B	30

(Right Shift Display)

0B	00	01	02	03	04	05	06	07	08	09	0A	→(0B)
1B	10	11	12	13	14	15	16	17	18	19	1A	→(1B)
2B	20	21	22	23	24	25	26	27	28	29	2A	→(2B)
3B	30	31	32	33	34	35	36	37	38	39	3A	→(3B)

Note : The left and right shift performs only in same line, the display data do not change to other line.

(1-5) Character Generator ROM (CG ROM)

The Character Generator ROM (CG ROM) generates 5 x 7 dots character pattern represented in 8-bit character code.

The storage capacity is up to 252 kinds of 5 x 7 dots character pattern(available address is (04)H through (FF)H).

The correspondence between character code and standard character pattern of NJU6620 is shown in Table 2-1.

User-defined character patterns (Custom Font) are also available by mask option.

Table 2-1. CG ROM Character Pattern (ROM version -02)

		Upper 4 bit (Hexadecimal)															
		0	1	2	3	4	5	6	7	8	9	A	B	C	D	E	F
Lower 4 bit (Hexadecimal)	0	CG RAM (01)	␣		0	a	P	`	p	0	é		—	9	3	0	p
	1	(02)	E	!	1	A	O	a	4	0	a	.	7	7	4	3	9
	2	(03)	á	"	2	B	R	b	r	é	E	'	4	7	×	3	0
	3	(04)	i	#	3	C	S	c	s	á	ò	.	7	7	E	3	.
	4		ó	\$	4	D	T	d	t	á	ö	.	I	†	†	μ	0
	5		ú	%	5	E	U	e	u	á	ò	.	7	7	1	3	0
	6		À	&	6	F	V	f	v	á	ò	.	7	7	2	3	0
	7		À	'	7	G	W	g	w	á	ò	.	7	7	7	9	π
	8		á	(8	H	X	h	x	á	ö	.	7	7	U	7	π
	9		0)	9	I	Y	i	y	á	ö	.	7	7	U	7	π
	A		¿	*	:	J	Z	j	z	á	ö	.	7	7	U	7	π
	B		7	+	:	K	L	k	l	á	ö	.	7	7	E	0	*
	C		7	,	<	L	¶	l	¶	á	ö	.	7	7	7	7	π
	D		i	—	=	M	I	m)	á	ö	.	7	7	U	7	π
	E		×	.	>	N	^	n	+	á	ö	.	7	7	E	0	*
	F		✳	/	?	O	_	o	+	á	ö	.	7	7	U	7	π

(1-6) Character Generator RAM (CG RAM)

The character generator RAM (CG RAM) can store any kind of character pattern in 5 x 7 dots written by the user program to display user's original character pattern. The CG RAM can store 4 kind of character in 5 x 7 dots mode.

To display user's original character pattern stored in the CG RAM, the address data (00)H-(03)H should be written to the DD RAM as shown in Table 2-1.

Table 3. show the correspondence among the character pattern, CG RAM address and Data.

Table 3. Correspondence of CG RAM address, DD RAM character code and CG RAM character pattern (5 x 7 dots)

Character Code (DD RAM data)	CG RAM Address		Character Pattern (CG RAM data)
7 6 5 4 3 2 1 0 ← → Upperbit Lower bit	7 6 5 4 3 2 1 0 ← → Upperbit Lower bit		← 4 3 2 1 0 Upper bit Lower bit
00000000	01000	000 001 010 011 100 101 110 111	 Character Pattern Example(1) ←Cursor Position
00000001	01001	000 001 010 011 100 101 110 111	 Character Pattern Example(2) ←Cursor Position
		000 001	
⋮	⋮	⋮	⋮
00000011	01011	100 101 110 111	

- Notes :
1. Character code bit 0,1 correspond to the CG RAM address bit 3,4(2bits:4 patterns).
 2. CG RAM address 0 to 2 designate character pattern line position. The 8th line is the cursor position and the display is performed by logical OR with cursor. Therefore, in case of the cursor display, the 8th line should be "0". If there is "1" in the 8th line, the bit "1" is always displayed on the cursor position regardless of cursor existence.
 3. Character pattern row position correspond to the CG RAM data bits 0 to 4 are shown above.
 4. CG RAM character patterns are selected when character code bits 2 to 7 are all "0" and these are addressed by character code bits 0 and 1.
 5. "1" for CG RAM data corresponds to display On and "0" to display Off.

(1-7) Icon Display RAM (MK RAM)

The NJU6620 can display maximum 128 Icons.

The Icon Display can be controlled by writing the Data in MK RAM corresponds to the Icon. The relation between MK RAM address and Icon Display position is shown below:

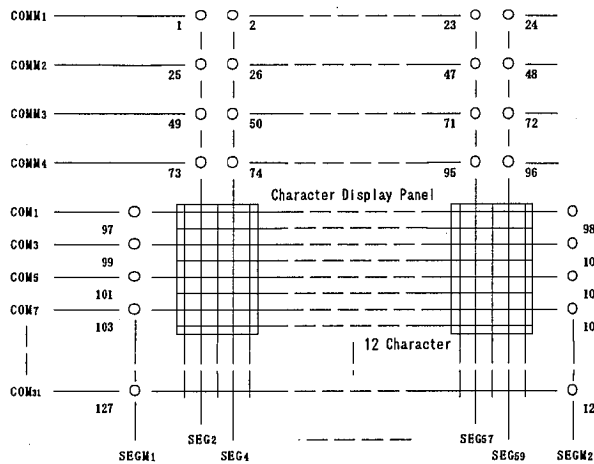

Table 4. Correspondence among Icon Position, MK RAM Address and Data

MK RAM Address		Bits for Icon Display Position							
		D7	D6	D5	D4	D3	D2	D1	D0
0110 0000	60 _H	*	*	*	1	2	3	4	97
0110 0001	61 _H	*	*	*	5	6	7	8	98
:	:	:							
0110 0101	65 _H	*	*	*	21	22	23	24	102
0110 0110	66 _H	*	*	*	*	*	*	*	103
0110 0111	67 _H	*	*	*	*	*	*	*	104
0110 1000	68 _H	*	*	*	25	26	27	28	105
0110 1001	69 _H	*	*	*	29	30	31	32	106
:	:	:							
0110 1101	6D _H	*	*	*	45	46	47	48	110
0110 1110	6E _H	*	*	*	*	*	*	*	111
0110 1111	6F _H	*	*	*	*	*	*	*	112
0111 0000	70 _H	*	*	*	49	50	51	52	113
0111 0001	71 _H	*	*	*	53	54	55	56	114
:	:	:							
0111 0101	75 _H	*	*	*	69	70	71	72	118
0111 0110	76 _H	*	*	*	*	*	*	*	119
0111 0111	77 _H	*	*	*	*	*	*	*	120
0111 1000	78 _H	*	*	*	73	74	75	76	121
0111 1001	79 _H	*	*	*	77	78	79	80	122
:	:	:							
0111 1101	7D _H	*	*	*	93	94	95	96	126
0111 1110	7E _H	*	*	*	*	*	*	*	127
0111 1111	7F _H	*	*	*	*	*	*	*	128

- Notes:
- When the Icon display function using, the system should be initialized by the software initialization because the MK RAM is not initialized by the power turning on and hardware reset.
 - The cross-points between SEG1, SEG2 and some of common COM1 through COM4, even common likes as COM2, COM4...COM32, are always off because of the corresponding RAM does not exist as shown above.
 - In the table 4, the bits D5 to D7 mentioned by * are invalid, therefore both of "0" or "1" can be written but these are no meaning.

(1-8) Timing Generator

The timing generator generates a timing signals for the DD RAM, CG RAM and MK RAM and other internal circuits.

RAM read timing for the display and internal operation timing for MPU access are separately generated, so that they may not interfere with each other.

Therefore, when the data write to the DD RAM for example, there will be no undesirable influence, such as flickering, in areas other than the display area.

(1-9) LCD Driver

LCD Driver consist of 37-common driver and 63-segment driver.

The character pattern data are latched to the addressed Segment-register respectively. This latched data controls display driver to output LCD driving waveform.

(1-10) Cursor Blinking Control Circuit

This circuits controls cursor On/Off and the cursor position character blinks.

The cursor or blinks appear in the digit residing at the DD RAM address set in the address counter (AC).

When the address counter is (08)H, a cursor position is shown as follows:

	AC ₆	AC ₅	AC ₄	AC ₃	AC ₂	AC ₁	AC ₀
AC	0	0	0	1	0	0	0

4-Line display

	1	2	3	4	5	6	7	8	9	10	11	12	←Display position
1st Line	00	01	02	03	04	05	06	07	08	09	0A	0B	←DD RAM address (Hexadecimal)
2nd Line	10	11	12	13	14	15	16	17	18	19	1A	1B	
3rd Line	20	21	22	23	24	25	26	27	28	29	2A	2B	
4th Line	30	31	32	33	34	35	36	37	38	39	3A	3B	

↙ Cursor position

Note : The cursor or blinks also appear when the address counter (AC) selects the CG RAM or the MK RAM. But the displayed cursor and blink are meaningless.

If the AC storing the CG or MK RAM address data, the cursor and blink are displayed in the meaningless position.

(2) Power on Initialization by internal circuits

(2-1) Initialization By Internal Reset Circuits

The NJU6620 is automatically initialized by internal power on initialization circuits when the power is turned on. In the internal power on initialization, following instructions are executed. During the Internal power on initialization, the busy flag (BF) is "1" and this status is kept 7 ms ($f_{osc}=212kHz$) after VDD rises to 2.4V.

Initialization flow is shown below:

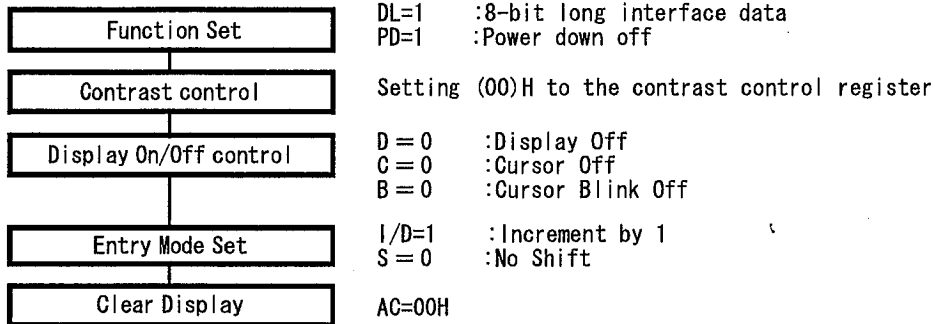

Note : If the condition of power supply rise time described in the Electrical Characteristics is not satisfied, the internal Power On Initialization Circuits will not operated and initialization will not performed.
In this case the initialization by MPU software is required.

(2-2) Initialization By Hardware

The NJU6620 incorporates RESET terminal to initialize the all system. When the "L" level input over 1.2ms to the RESET terminal, reset sequence is executed. In this time, busy signal output during 7 ms ($f_{osc}=212kHz$) after RESET terminal goes to "H".

-Timing Chart

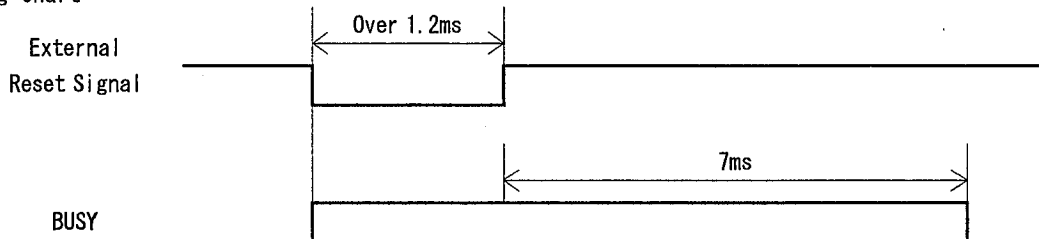

(3) Instructions

The NJU6620 incorporates two registers, an Instruction Register (IR) and a Data Register (DR). These two registers store control information temporarily to allow interface between NJU6620 and MPU or peripheral ICs operating different cycles. The operation of NJU6620 is determined by this control signal from MPU. The control information includes register selection signals (RS), read/write signals (R/W) and data bus signals (DB0 to DB7). Table 5. shows each instruction and its operating time.

Note : The execution time mentioned in Table 5. based on f_{cp} or $f_{osc}=212kHz$.
If the oscillation frequency is changed, the execution time is also changed.

Table 4. Table of Instructions

INSTRUCTIONS	C O D E											DESCRIPTION	Execute Time f _{osc} = 212KHz
	RS	R/W	DB ₇	DB ₆	DB ₅	DB ₄	DB ₃	DB ₂	DB ₁	DB ₀			
Maker Testing	0	0	0	0	0	0	0	0	0	0	0	All "0" code is using for maker testing.	—
Clear Display	0	0	0	0	0	0	0	0	0	0	1	Display clear and sets RAM address (00)H in AC.	6.87ms
Return Home	0	0	0	0	0	0	0	0	0	1	*	Sets RAM address (00)H in AC and returns display being shifted original position. RAM contents remain unchanged.	141 μs
Entry Mode Set	0	0	0	0	0	0	0	0	1	I/D	S	Sets cursor move direction and specifies shift of display are performed in data read/write. I/D=1: Increment, I/D=0: Decremen S=1: Accompanies display shift	0 μs
Display ON/OFF Control	0	0	0	0	0	0	0	1	D	C	B	Sets of display On/Off (D), cursor On/Off (C) and blink of cursor position character (B).	0 μs
Cursor or Display Shift	0	0	0	0	0	0	1	S/C	R/L	*	*	Moves cursor & shifts display without changing RAM contents S/C=1: Display shift S/C=0: Cursor shift R/L=1: Shift to the right R/L=0: Shift to the left	cursor: 141 μs display: 0 μs
Function Set	0	0	0	0	0	1	DL	*	*	*	PD	Sets interface data length (DL) and power down mode (PD).	PD=0: 0 μs PD=1: 200 μs
Contrast control	0	0	0	1	*	*	←←←	Cc	→→→			Sets data to Contrast Control Register.	0 μs
Set RAM Address	0	0	1	←←←			AR				→→→	Sets RAM address. After this instruction, the data is transferred to/from RAM.	141 μs
Read Busy Flag & AC contents	0	1	BF	←←←			AC				→→→	Reads busy flag and AC content BF=1: Internally operating BF=0: Can accept instruction	0 μs
Write Data to RAM	1	0	←←←				Write Data (DD RAM)				→→→	Writes data into RAM.	141 μs
	1	0	*	*	*	←←←	(CG RAM)				→→→		
	1	0	*	*	*	←←←	(MK RAM)				→→→		
Read Data from RAM	1	1	←←←				Write Data (DD RAM)				→→→	Reads data from RAM.	141 μs
	1	1	*	*	*	←←←	(CG RAM)				→→→		
	1	1	*	*	*	←←←	(MK RAM)				→→→		
Explanation of Abbreviation	DD RAM : Display data RAM, CG RAM : Character generator RAM, MK RAM : Icon display RAM, AR : RAM address (both of DD, CG and MK RAM) AC : Address counter used for both of DD, CG and MK RAM												

*:Don't care

(3-1) Description of each instructions

(a) Maker Testing

	RS	R/W	DB ₇	DB ₆	DB ₅	DB ₄	DB ₃	DB ₂	DB ₁	DB ₀
Code	0	0	0	0	0	0	0	0	0	0

All "0" code in 4-bit length is using for device testing mode (only for maker). Therefore, please avoid all "0" input or no meaning Enable signal input at data "0". (Especially please pay attention the output condition of Enable signal when the power turns on.)

(b) Clear Display

	RS	R/W	DB ₇	DB ₆	DB ₅	DB ₄	DB ₃	DB ₂	DB ₁	DB ₀
Code	0	0	0	0	0	0	0	0	0	1

Clear display instruction is executed when the code "1" is written into DB₀. When this instruction is executed, the space code (20)H is written into every DD RAM address, the DD RAM address (00)H is set into the address counter and entry mode is set increment. If the cursor or blink are displayed, they are returned to the left end of the 1st line in the LCD. The S of entry mode does not change.

Note: The character pattern for character code (20)H must be blank code in the user-defined character pattern(Custom font).

(c) Return Home

	RS	R/W	DB ₇	DB ₆	DB ₅	DB ₄	DB ₃	DB ₂	DB ₁	DB ₀	
Code	0	0	0	0	0	0	0	0	1	*	* =Don't Care

Return home instruction is executed when the code "1" is written into DB₁. When this instruction is executed, the DD RAM address (00)H is set into the address counter. Display is returned its original position if shifted, the cursor or blink are returned to the left end of the 1st line in the LCD if the cursor or blink are on the display. The DD RAM contents do not change.

(d) Entry Mode Set

	RS	R/W	DB ₇	DB ₆	DB ₅	DB ₄	DB ₃	DB ₂	DB ₁	DB ₀
Code	0	0	0	0	0	0	0	1	I/D	S

Entry mode set instruction which sets the cursor moving direction and display shift On/Off, is executed when the code "1" is written into DB₂ and the codes of (I/D) and (S) are written into DB₁(I/D) and DB₀(S), as shown below.

(I/D) sets the address increment or decrement, and the (S) sets the entire display shift in the DD RAM writing.

I/D	F u n c t i o n
1	Address increment: The address of the DD RAM or CG RAM increment (+1) when the read/write, and the cursor or blink move to the right.
0	Address decrement: The address of the DD RAM or CG RAM decrement (-1) when the read/write, and the cursor or blink move to the left.
S	F u n c t i o n
1	Entire display shift. The shift direction is determined by I/D.: shift to the left at I/D=1 and shift to the right at the I/D=0. The shift is operated only for the character, so that it looks as if the cursor stands still and the display moves. The display does not shift when reading from the DD RAM and writing/reading into/from CG RAM.
0	The display does not shift.

(e) Display ON/OFF Control

	RS	R/W	DB ₇	DB ₆	DB ₅	DB ₄	DB ₃	DB ₂	DB ₁	DB ₀
Code	0	0	0	0	0	0	1	D	C	B

Display On/Off control instruction which controls the whole display On/Off, the cursor On/Off and the cursor position character blink, is executed when the code "1" is written into DB₃ and the codes of (D), (C) and (B) are written into DB₂(D), DB₁(C) and DB₀(B), as shown below.

D	Function
1	Display On.
0	Display Off. In this mode, the display data remains in the DD RAM so that it is retrieved immediately on the display when the D change to 1.

C	Function
1	Cursor On. The cursor is displayed by 5 dots on the 8th line.
0	Cursor Off. Even if the display data write, the I/D etc does not change

B	Function
1	The cursor position character is blinking. Blinking rate is 439ms at fosc=212kHz. The cursor and the blink can be displayed simultaneously.
0	The character does not blink.

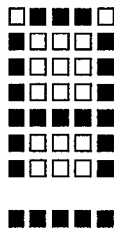

Character Font 5 x 7 dots

(1) Cursor display example

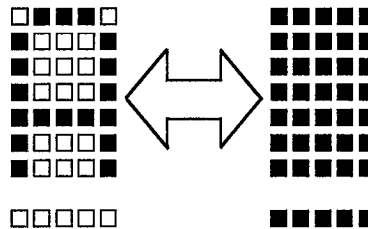

Alternating display

(2) Blink display example

(f) Cursor/Display Shift

	RS	R/W	DB ₇	DB ₆	DB ₅	DB ₄	DB ₃	DB ₂	DB ₁	DB ₀	
Code	0	0	0	0	0	1	S/C	R/L	*	*	* =Don't Care

The Cursor/Display shift instruction shifts the cursor position or display to the right or left without writing or reading display data. This function is used to correct or search the display. The cursor moves to the 2nd line when it passes the 12th digit of the 1st line. Notice that the every 1st to 3rd line displays shift at the same time. When the displayed data are shifted repeatedly, each line moves only horizontally.

The 2nd and 3rd line display does not shift into the 1st and 2nd line.

The contents of address counter(AC) does not change by operation of the display shift only. This instruction is executed when the code "1" is written into DB₄ and the codes of (S/C) and (R/L) are written into DB₃(S/C) and DB₂(R/L), as shown below.

S/C	R/L	F u n c t i o n
0	0	Shifts the cursor position to the left ((AC) is decremented by 1)
0	1	Shifts the cursor position to the right ((AC) is incremented by 1)
1	0	Shifts the entire display to the left and the cursor follows it.
1	1	Shifts the entire display to the right and the cursor follows it.

(g) Function Set

	RS	R/W	DB ₇	DB ₆	DB ₅	DB ₄	DB ₃	DB ₂	DB ₁	DB ₀	
Code	0	0	0	0	1	DL	*	*	*	PD	* =Don't Care

Function set instruction which sets the interface data length and powerdown mode, is executed, when the code "1" is written into DB₅ and the code of (DL) and (PD) is written into DB₄ (DL) and DB₀ (PD), as shown below. In the serial interface operation, the DL is not cared.

When the powerdown mode is set, the display is off automatically (D=0). Afterward, when the powerdown mode is reset, the display is off continuously. The display is appeared by the display on (D="1") instruction.

Note : This function set instruction must be performed at the head of the program prior to all other existing instructions(except Busy flag/Address read). This function set instruction can not be executed afterwards unless the interface data length change.

DL	F u n c t i o n
1	Set the interface data length of 8-bit (using from DB ₇ to DB ₀) in the parallel operation only
0	Set the interface data length of 4-bit (using from DB ₇ to DB ₄) in the parallel operation only the data must be sent or received twice in this mode.

PD	F u n c t i o n
1	Power down mode off (Normal operation)
0	Power down mode on (The display goes to off automatically.)

Note : When the Power down mode, it must be not execution except for this instruction.

(h) Contrast Control

	RS	R/W	DB ₇	DB ₆	DB ₅	DB ₄	DB ₃	DB ₂	DB ₁	DB ₀	
Code	0	0	0	1	*	*	C ₃	C ₂	C ₁	C ₀	* =Don't Care

Contrast Control instruction which adjusts the contrast of the LCD, is executed when the code "1" is written into DB6 and the codes of C3 to C0 are written into DB3 to DB0 as shown below.

The contrast of LCD can be adjusted one of 16 voltage stage by setting this 4-bit register. See (5-1) to realize "how to adjust the Contrast of LCD".

Set the binary code "0000" when contrast adjustment is unused.

C ₃	C ₂	C ₁	C ₀	V _{LCD}	$V_{LCD} = V_{DD} - V_5$
0	0	0	0	low	
1	1	1	1	high	

(i) Set RAM Address

	RS	R/W	DB ₇	DB ₆	DB ₅	DB ₄	DB ₃	DB ₂	DB ₁	DB ₀
Code	0	0	1	A	A	A	A	A	A	A
			←Higher order bit				Lower order bit→			

The RAM address set instruction is executed when the code "1" is written into DB7 and the address is written into DB6 to DB0 as shown above.

The address data (DB6 to DB0) is written into the address counter (AC) by this instruction. After this instruction execution, the data writing/reading is performed into/from the addressed RAM.

The RAM includes DD RAM, CG RAM and MK RAM, and these RAMs are shared by address as shown below.

	RAM Address
DD RAM 1st Line	: from (00)H to (0B)H
DD RAM 2nd Line	: from (10)H to (1B)H
DD RAM 3rd Line	: from (20)H to (2B)H
DD RAM 4th Line	: from (30)H to (3B)H
CG RAM 4 characters	: from (40)H to (5F)H
MK RAM 128 icons	: from (60)H to (7F)H

(j) Read Busy Flag & AC contents

	RS	R/W	DB ₇	DB ₆	DB ₅	DB ₄	DB ₃	DB ₂	DB ₁	DB ₀
Code	0	1	BF	A	A	A	A	A	A	A
			←Higher order bit				Lower order bit→			

This instruction reads out the internal status of the NJU6620. When this instruction is executed, the busy flag (BF) stored in DB7 and the address counter (AC) contents stored in DB6 to DB0 are read out.

The (BF)="1" indicates that internal operation is in progress. The next instruction is inhibited when (BF)="1". Check the (BF) status before the next write operation.

(k) Write Data to RAM

Write Data to RAM instruction is executed when the code "1" is written into (RS) and code "0" is written into (R/W).

By the execution of this instruction, the binary 8-bit data (A7 to A0) are written into the DD RAM, and the binary 5-bit data (A4 to A0) are written into the CG or MK RAM. The selection of RAM is determined by the previous instruction. After this instruction execution, the address increment(+1) or decrement(-1) is performed automatically according to the entry mode set. And the display shift is also executed according to the previous entry mode set.

·Write Data to DD RAM

	RS	R/W	DB ₇	DB ₆	DB ₅	DB ₄	DB ₃	DB ₂	DB ₁	DB ₀
Code	1	0	D	D	D	D	D	D	D	D
	←Higher order bit					Lower order bit→				

·Write Data to CG or MK RAM

	RS	R/W	DB ₇	DB ₆	DB ₅	DB ₄	DB ₃	DB ₂	DB ₁	DB ₀
Code	1	0	*	*	*	D	D	D	D	D
	←Higher order bit					Lower order bit→				

* =Don't Care

(l) Read Data from MK RAM

Read Data from RAM instruction is executed when the code "1" is written into (RS) and (R/W). By the execution of this instruction, the binary 8-bit data (D7 to D0) are read out from the DD RAM, the binary 5-bit data (D4 to D0) are read out from the CG or MK RAM. The selection of RAM is determined by previous instruction. Before executing this instruction, RAM address set must be executed, otherwise the read out data are invalidated.

When this instruction is serially executed, the next address data is normally read from the second read.

The RAM address set instruction is not required if the cursor shift instruction is executed just beforehand (only DD RAM reading). The cursor shift instruction has same function as the DD RAM address set, so that after reading the DD RAM, the address increment or decrement is executed automatically according to the entry mode.

But display shift does not occur regardless of the entry mode.

Note : The address counter(AC) is automatically incremented or decremented by 1 after write instruction to either of the DD RAM, CG RAM or DD RAM. Even if the read instruction is executed after this write instruction, the addressed data can not be read out correctly.

For a correct data read out, either the address set instruction or cursor shift instruction (only with DD RAM) must be implemented just before this instruction or from the second time read out instruction execution if the read out instruction is executed 2 times consecutively.

·Read Data from DD RAM

	RS	R/W	DB ₇	DB ₆	DB ₅	DB ₄	DB ₃	DB ₂	DB ₁	DB ₀
Code	1	1	D	D	D	D	D	D	D	D
	←Higher order bit					Lower order bit→				

·Read Data from CG or MK RAM

	RS	R/W	DB ₇	DB ₆	DB ₅	DB ₄	DB ₃	DB ₂	DB ₁	DB ₀
Code	1	1	*	*	*	D	D	D	D	D
	←Higher order bit					Lower order bit→				

* =Don't Care

(3-2) Initialization using the internal reset circuits

(a) 8-bit operation (Using internal reset circuits).

The Function set, Display On/Off Control and Entry Set Instruction must be executed before the data input, as shown below.

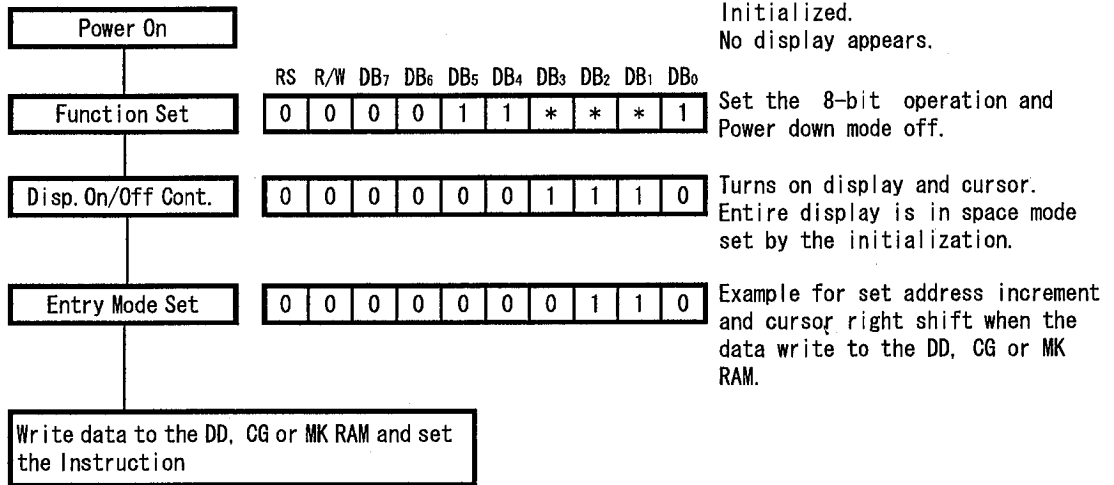

(b) 4-bit operation (Using internal reset circuits).

In the 4-bit operation, the function set must be performed by the user programming. When the power is turned on, 8-bit operation is selected automatically, therefore the first input is performed under 8-bit operation. In this operation, full instruction can not input because of terminals DB0 to DB3 are no connection. Therefore, same instruction must be rewritten on the RS, R/W and DB7 to DB4, as shown below. Since one operation is completed by the two accesses in the 4-bit operation mode, rewrite is required to set the instruction code in full.

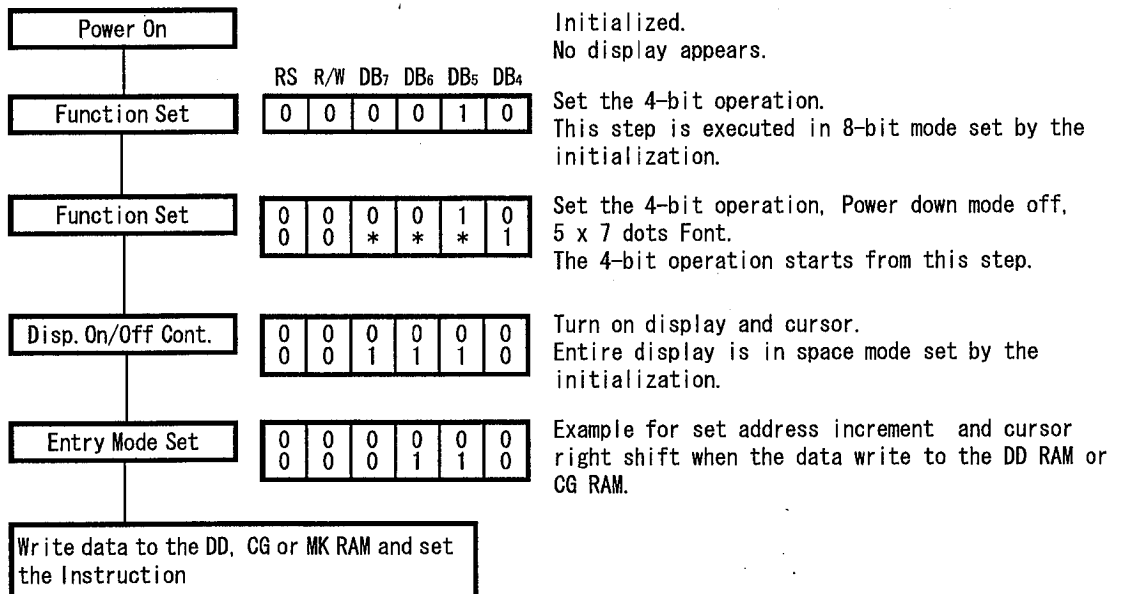

Note : When the Icon display function using, the system should be initialized by software initialization.

(3-3) Initialization by instruction

If the power supply conditions for the correct operation of the internal reset circuits are not met, the NJU6620 must be initialized by the instruction.

(a) Initialization by Instruction in 8-bit interface length.

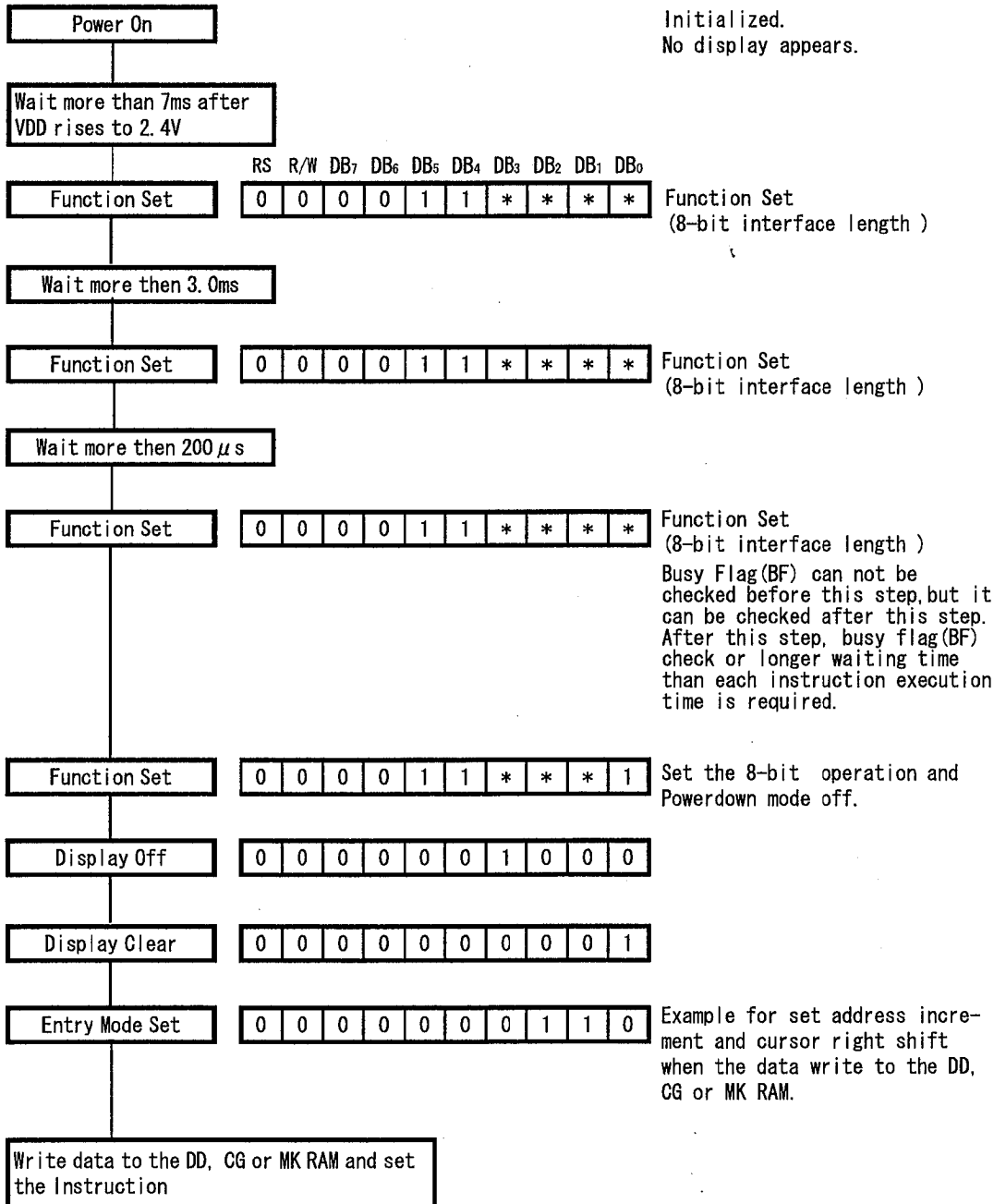

Note : When the Icon display function using, the system should be initialized by software initialization.

(b) Initialization by Instruction in 4-bit interface length

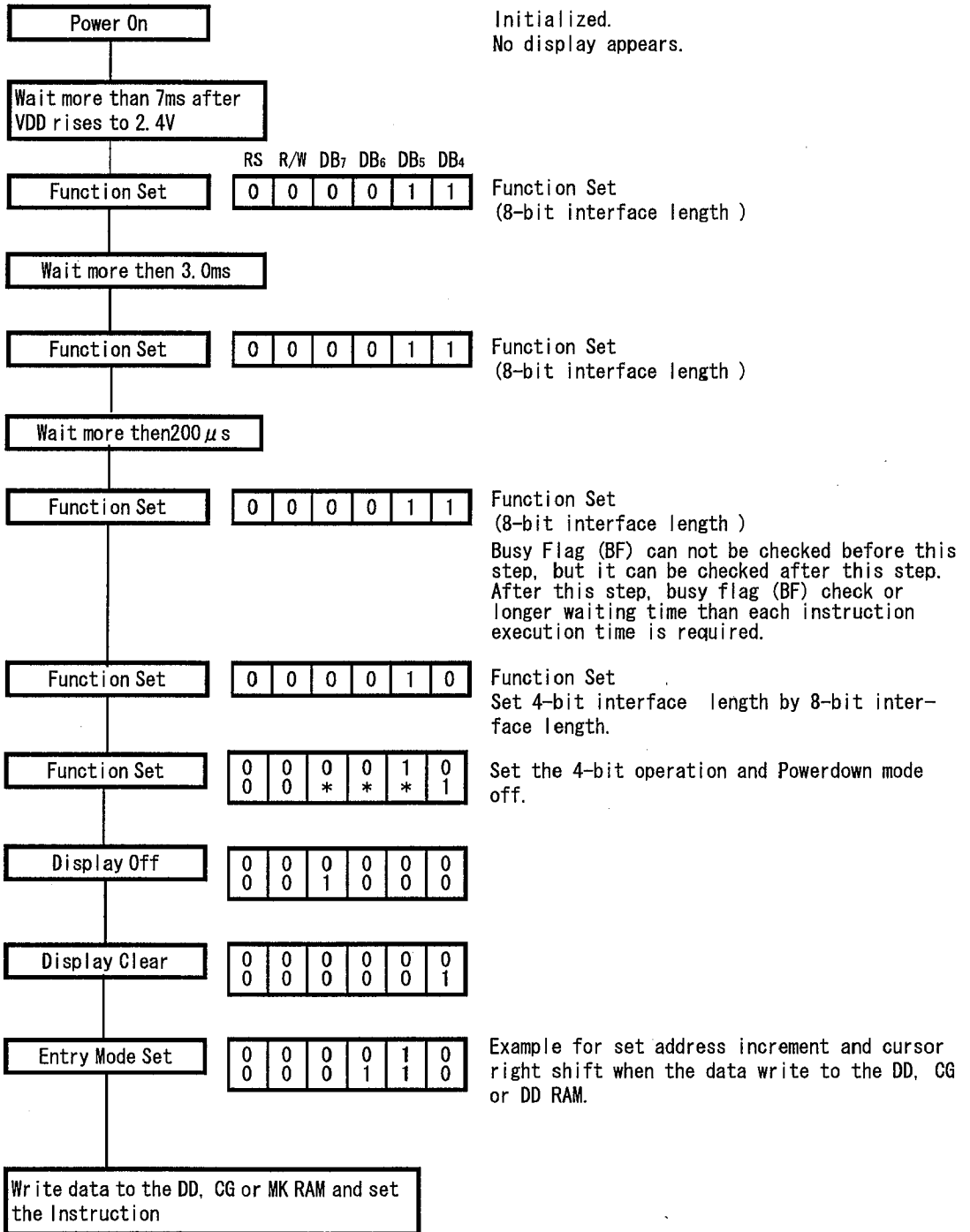

Note : When the Icon display function using, the system should be initialized by software initialization.

(4) Powerdown Function

NJU6620 incorporates the powerdown mode to decrease the operating current.

The powerdown mode can be set/reset by the function set instruction.

In the powerdown mode, all the character display (12-character 4-line) and icon display turn off and only the static display area operates automatically.

The status of internal circuits at the powerdown mode is shown below :

- Main oscillator stops operation and sub oscillator for the static display starts operations.
- Voltage converter, voltage regulator and buffer amplifire for the bleeder resistance stop the operation.
- The contents of DD RAM, CG RAM and MK RAM are kept.

(5) LCD display

(5-1) Power Supply for LCD Driving

NJU6620 incorporates Voltage converter (tripler or doubler) to generate the LCD driving high voltage, Voltage regulator to adjust the LCD driving voltage, Bleeder resistance and buffer amplifire.

(a) Voltage converter

- Voltage tripler

By connecting the capacitor between C1+ and C1-, C2+ and C2-, VSS and V50UT respectively, two times negative voltage of VDD-VSS output from V50UT.

- Voltage doubler

By connecting the capacitor between C2+ and C2-, VSS and V50UT respectively, and connecting the C1+ terminal to C2+ terminal, and C1- terminal being open, negative voltage of VDD-VSS output from V50UT.

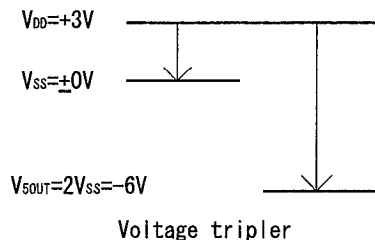
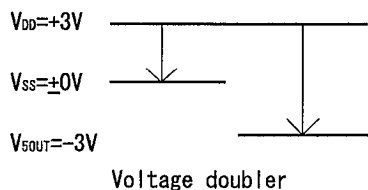

(b) Voltage Regulator

Voltage Regulator incorporates a non-inverting OP-AMP which supplied VDD and V50UT, and a reference voltage source.

By setting the VR level by connecting Ra and Rb, the regulator which amplifies VREF output the LCD driving voltage to the VREG terminal.

Therefore, the LCD operating voltage can be output between VDD and VREG by setting VREF and the external resistances Ra and Rb.

$$V_{REG} = (1 + R_b/R_a) \cdot V_{REF} \quad \text{where, } V_{DD} = 0V \quad \text{and} \quad |V_{REG}| < |V_{50UT}|$$

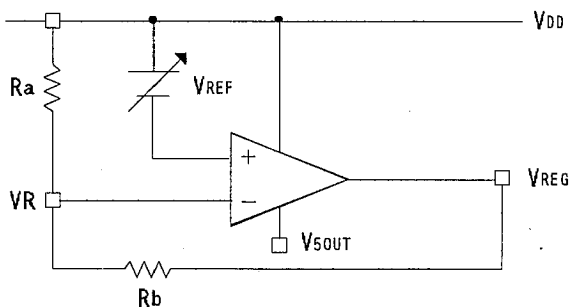

The contrast control function performs VREF value adjustment from 1st step to 16th step by a step setting when the 4-bit data write into the contrast control register by the instruction.

Note : Set the contrast control register to (00)H when the contrast control function is unused.
 Use variable resistances to the external resistances Ra, Rb and a thermister if need due to the voltage reference VREF is changed by the lot and operating temperature.
 Take care the Noise input on the VR terminal because of it designed in high impedance.
 Short wiring or sealed wiring are required to avoid the noise input, if necessary.

[The Voltage Reference VREF characteristics]

Supply Voltage : VDD= 0V, VSS= -3V Temperature : 25°C

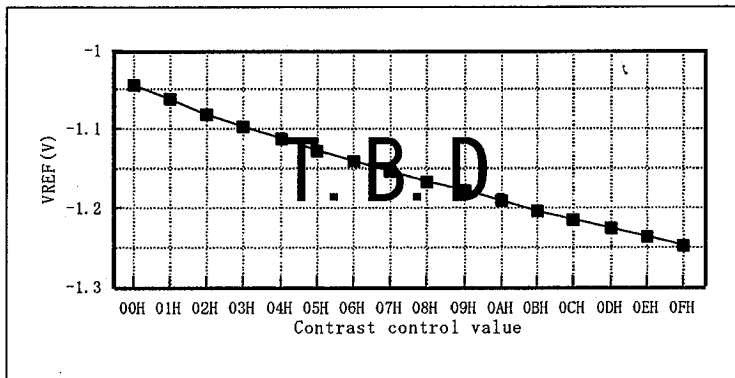

[The LCD Operating Voltage VREG characteristics]

Supply Voltage : VDD= 0V, VSS= -3V Voltage Tripler Output : V50UT=-9V
 External Resistances : Ra = 180K Ω, Rb = 820K Ω Temperature : 25°C

Used Equation : $VREG(xx)H = (1 + 820k \Omega / 180k \Omega) \cdot VREF (xx)H$

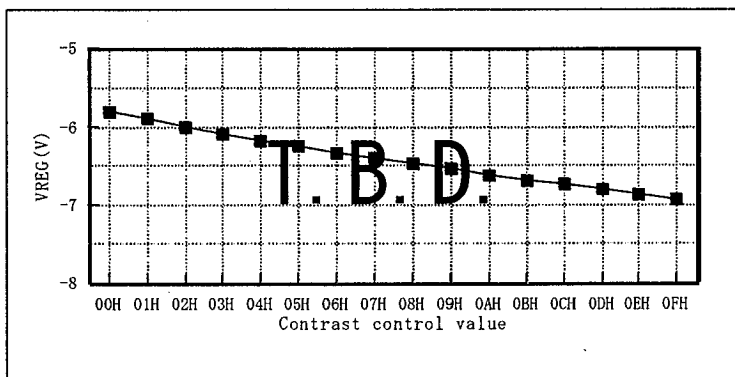

(c) Bleeder Resistance

Each LCD driving voltage (V₁, V₂, V₃, V₄) is generated by the high impedance bleeder resistance buffered by voltage follower OP-AMP to get a enough display characteristics with low operating current.

The bleeder resistance is set 1/7 bias suitable for 1/36 duty ratio and 5M Ω resistance in total. The capacitor connected between V₅ and V_{DD} is needed for stabilizing V₅. The determination of the each capacitance of C₁, C₂ and C₃ generating for LCD operating voltage, is required to operate with the LCD panel actually. The capacitance for the typical application is shown below :

LCD Driving Voltage vs Duty Ratio

Power supply	Duty Ratio	1/36
	Bias	1/7
V _{LCD}		V _{DD} - V ₅

V_{LCD} is the maximum amplitude for LCD driving voltage.

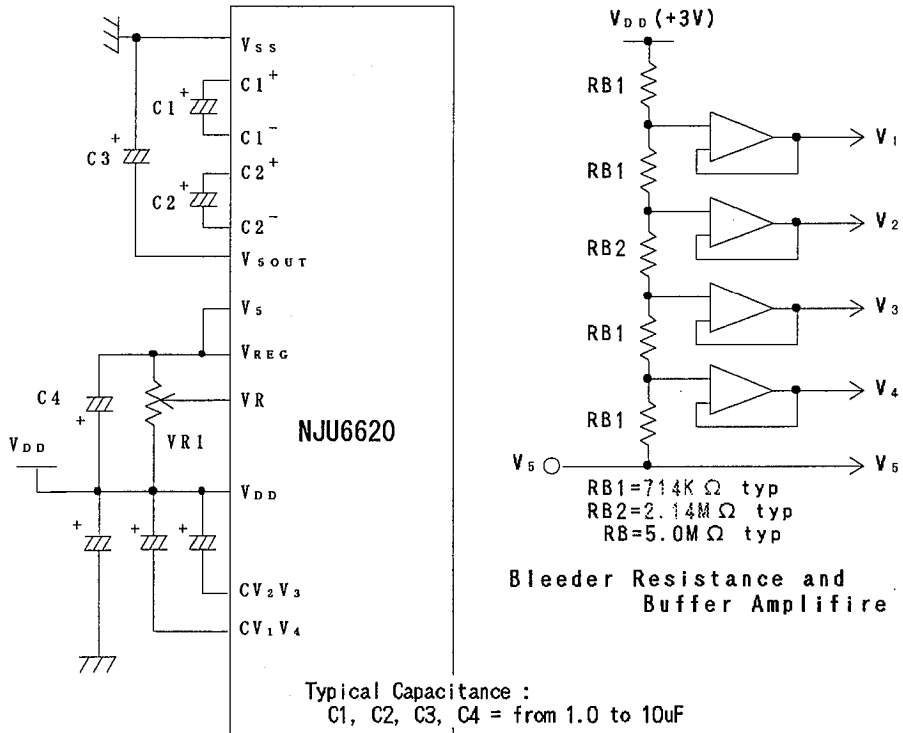

Typical application for LCD operating voltage generation

Note 1 : Take care the Noise input on the VR terminal as designed in high impedance. Short wiring or sealed wiring are required to avoid the noise input, if necessary.

Note 2 : The capacitor connected CV1V4 and CV2V3 terminals are required to operate with the LCD panel actually.

(5-2) Relation between oscillation frequency and LCD frame frequency

As the NJU6620 incorporate oscillation capacitor and resistor for CR oscillation, 192kHz oscillation is available without any external components.

The LCD frame frequency example mentioned below is based on ***kHz oscillation. (1clock = ****us)

1/36 duty ratio

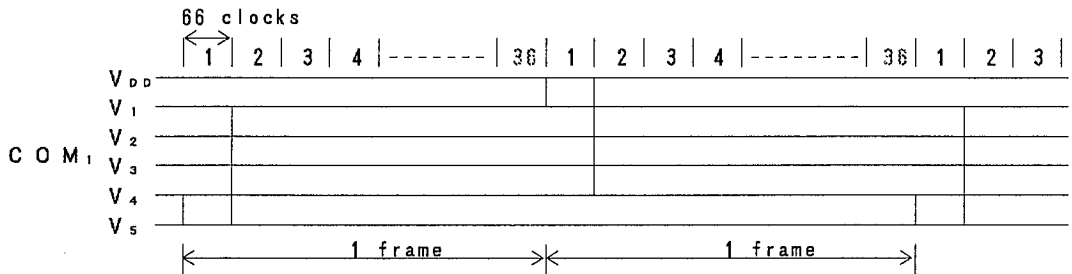

$$1 \text{ frame} = 4.76(\mu\text{s}) * 66 * 36 = 11.3(\text{ms})$$

$$\text{Frame frequency} = 1 / 11.3(\text{ms}) = 88.5(\text{Hz})$$

(6) Interface with MPU

Interface circuits of NJU6620 can be connected to serial or 4/8-bit parallel. NJU6620 can be interfaced with both of 4/8-bit MPU and the two-time 4-bit or one-time 8-bit data transfer is available.

(6-1) 4-bit MPU interface

When the interface length is 4-bit, the data transfer is performed by 4 lines connected to DB4 to DB7 (DB0 to DB3 are not used). The data transfer with the MPU is completed by the two time 4-bit data transfer.

The data transfer is executed in the sequence of upper 4-bit (the data DB4 to DB7 at 8-bit length) and lower 4-bit (the data DB0 to DB3 at 8-bit length).

The busy flag check can be executed after two-time 4-bit data transfer (1 instruction execution by two-time transfer). In this case, the data of busy flag and address counter contents are also output twice.

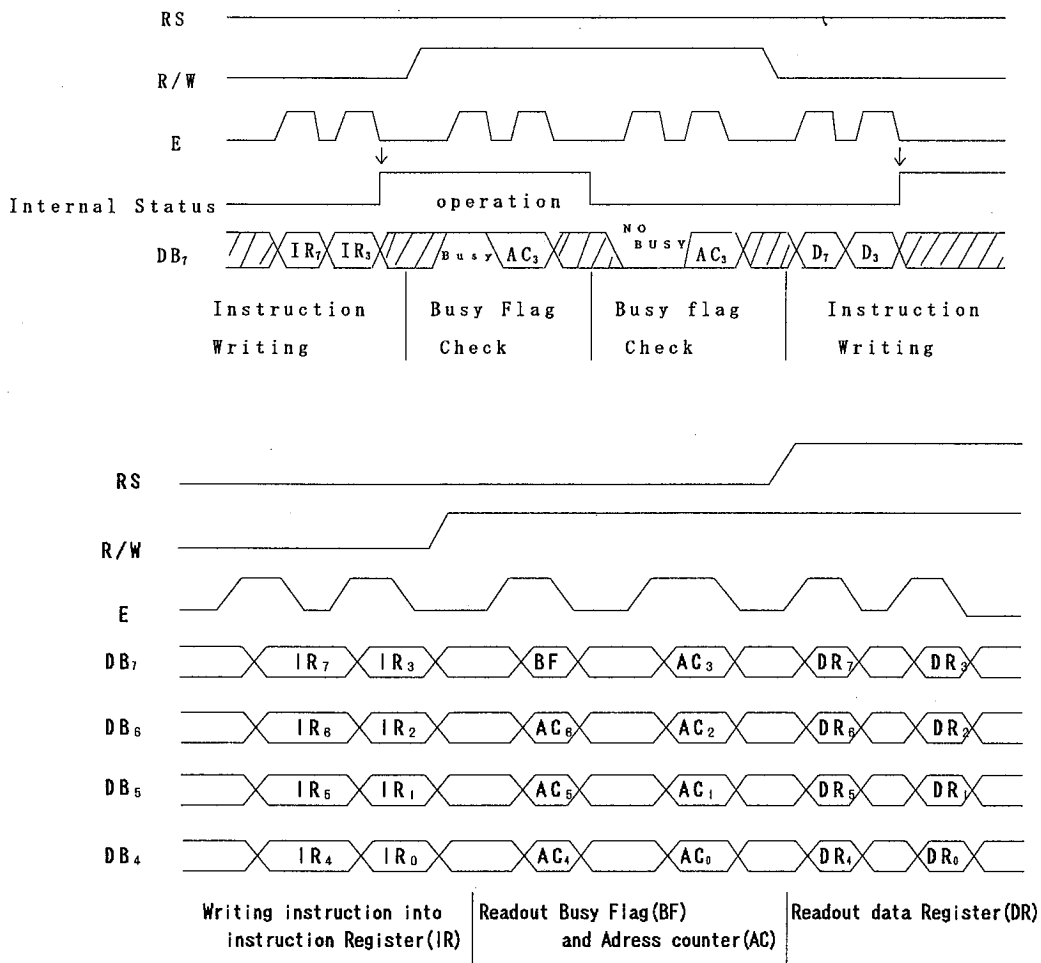

(6-2) 8-bit MPU interface

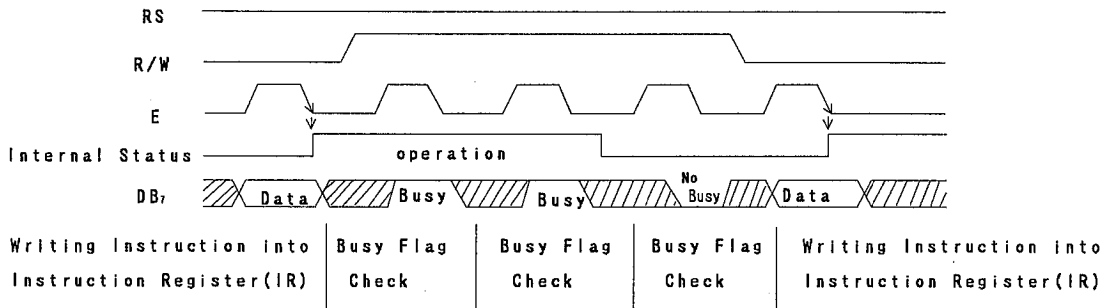

(6-3) Serial interface

Serial interface circuit is activated when the P/S terminal is set to "L" level then the chip select terminal (CS) goes to "L" level. The data input/output is MSB first like as the order of DB7, DB6 ... DB0.

The input data is entered into the shift register synchronized at the rise edge of the serial clock SCL. The shift register converted to parallel data at the CS rise edge input.

In case of entering over than 8-bit data, valid data is last 8-bit data.

The output data is exited from the shift register synchronized at the fall edge of the serial clock SCL.

The time chart for the serial interface is shown below.

Note : The level ("L" or "H") of RS and R/W terminals should be set before CS terminal goes to "L" level.

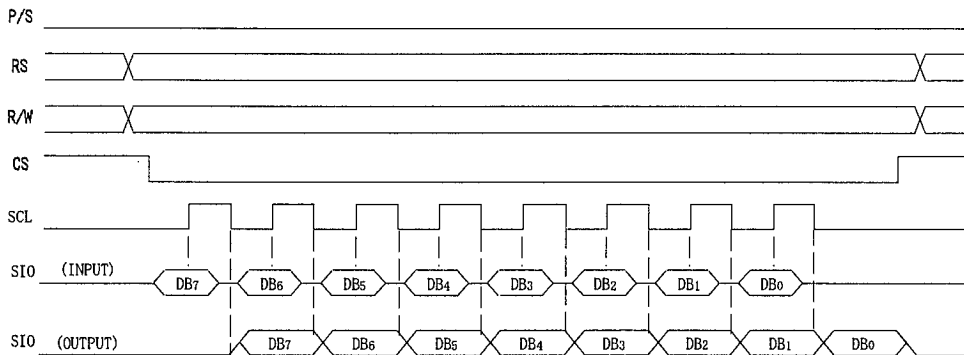

■ ABSOLUTE MAXIMUM RATINGS

(Ta=25°C)

PARAMETER	SYMBOL	RATINGS	UNIT	NOTE
Supply Voltage(1)	V _{DD}	-0.3~+7.0	V	
Supply Voltage(2)	V _{LCD}	V _{DD} -11.0~V _{DD} +0.3	V	
Input Voltage	V _{IN}	-0.3~V _{DD} +0.3	V	
Operating Temperature	T _{opr}	-30~+80	°C	
Storage Temperature	T _{stg}	-55~+125	°C	

Note 1 : If the LSI are used on condition above the absolute maximum ratings, the LSI may be destroyed. Using the LSI within electrical characteristics is strongly recommended for normal operation. Use beyond the electric characteristics conditions will cause mal function and poor reliability.

Note 2 : Decoupling capacitor should be connected between V_{DD} and V_{SS} due to the stabilized operation for the Voltage converter.

Note 3 : All voltage values are specified as V_{SS} = 0V

Note 4 : The relation : V_{DD} > V_{SS} , V_{DD} > V_{SS} ≥ V_{5OUT}, V_{SS}=0V must be maintained.

■ ELECTRICAL CHARACTERISTICS

(V_{DD}=2.4 ~ 3.3V, Ta=-20 ~ +75°C)

PARAMETER		SYMBOL	CONDITIONS	MIN.	TYP.	MAX.	UNIT	NOTE
Operation Voltage		V _{DD}		2.4	3.0	3.3	V	
Input Voltage		V _{IH}		0.8V _{DD}	—	V _{DD}	V	4
		V _{IL}		V _{SS}	—	0.2V _{DD}	V	5
Output Voltage		V _{OH}	I _{OH} =0.205mA, V _{DD} =3V	2.0	—	—	V	6
		V _{OL}	I _{OL} =1.6mA, V _{DD} =3V	—	—	0.5	V	
Driver On-resist. (COM)		R _{COM}	±I _G =1μA (All COM term.)	—	—	20	kΩ	9
Driver On-resist. (SEG)		R _{SEG}	±I _G =1μA (All SEG term.)	—	—	30	kΩ	
Input Leakage Current		I _{LI}	V _{IN} =0~V _{DD}	-1	—	1	μA	7
Pull-up MOS Current		-I _P	V _{DD} =3V, (All DB terminals)	10	25	50	μA	
Operating Current		I _{DD1}	V _{DD} =3V f _{osc} =Internal Osc. V _S =-5V during display	T. B. D.			μA	8
		I _{DD2}	V _{DD} =3V f _{osc} =Internal Osc. during access, T _{cyce} =5μs	T. B. D.			μA	
		I _{DD3}	V _{DD} =3V, f _{osc} =Internal Osc. during Powerdown mode	T. B. D.			μA	
Voltage Converter (Tripler)	Output Voltage	V _{5OUT}	V _{DD} =3V, Ta=25°C, I _{OUT} =100μA	—	-4.8	—	V	
	Voltage Efficiency	V _{ef}	R _L =∞	—	95.0	—	%	
Voltage Converter (Doubler)	Output Voltage	V _{5OUT}	V _{DD} =3V, Ta=25°C, I _{OUT} =100μA		-1.8	—	V	
	Voltage Efficiency	V _{ef}	R _L =∞		95.0	—	%	
Voltage Regulator	Reference Voltage	V _{REF}	Contrast Control (00)H. Ta=25°C	V _{DD} -0.75	V _{DD} -1.05	V _{DD} -1.35	V	
	Output Voltage	V _{REG}	R _L =∞, V _{5OUT} =-6V, R _{RV} =1MΩ. Contrast Control (00)H		V _{DD} -5.8			
Bleeder resistance		R _B	V _{DD} -V _S =3V	—	5	—	MΩ	
Oscillation Frequency		f _{osc}	V _{DD} =3V, Ta=25°C	135	212	289	kHz	
LCD Driving Voltage		V _{LCD}	V _{LCD} =V _{DD} -V _S	V _{DD} -5.0	—	V _{DD} -10.0	V	10
V5 Terminal Current		I _S	V _{DD} =3V, V _S =6V			200	μA	

Note 5 : Input/Output structure except LCD driver are shown below:

·Input Terminal Structure

E/SCL, RS, R/W, P/S, SEL Terminals

RESET Terminal



·Input/Output Terminal Structure

DB0 to DB7 Terminals

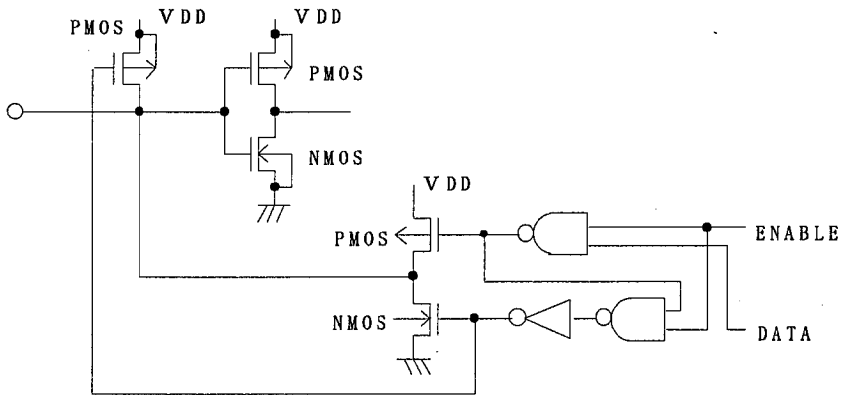

Note 6 : Apply to the Output and Input/Output Terminals.

Note 7 : Except pull-up resistance current and output driver current.

Note 8 : Except Input/output current but including the current flow on bleeder resistance.

If the input level is medium, current consumption will increase due to the penetration current. Therefore, the input level must be fixed to "H" or "L".

· Operating Current Measurement Circuit

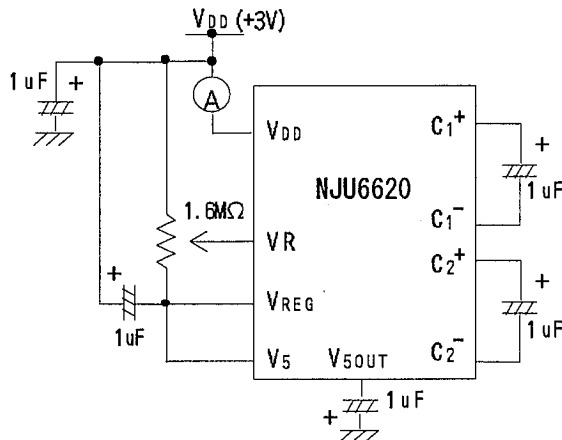

Note 9 : RCOM and RSEG are the resistance values between power supply terminals (VDD, V50UT) and each common terminal (COM1 to COM32, COMMK1 to COMMK4) and supply voltage (VDD, V50UT) and each segment terminal (SEG1 to SEG60, SEGM1 and SEGM2) respectively, and measured when the current I_d is flown on every common and segment terminals at a same time.

Note 10: Apply to the output voltage from each COM and SEG are less than $\pm 0.15V$ against the LCD driving constant voltage (VDD, V50UT) at no load condition.

Voltage Tripler Measurement Circuit

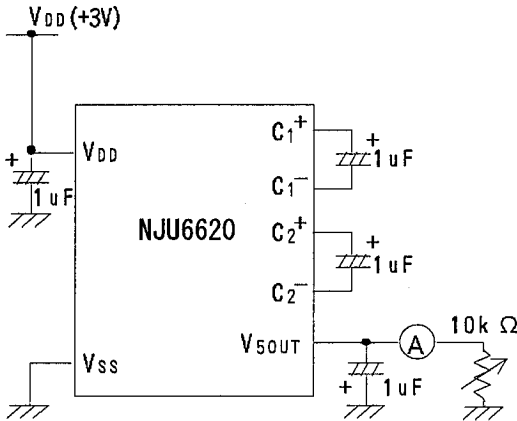

Voltage Doubler Measurement Circuit

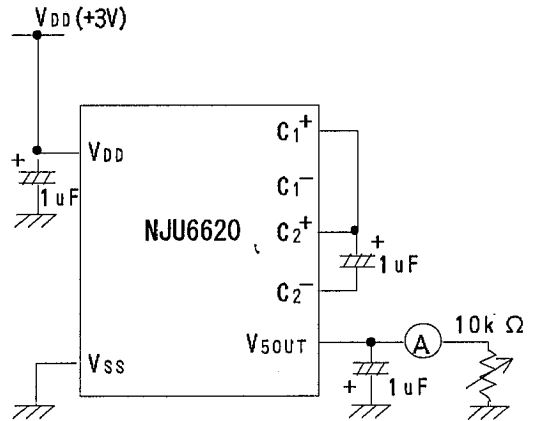

Voltage Tripler/Doubler
operation Clock Frequency = 10kHz

Bleeder Resistance
and Buffer Amplifier

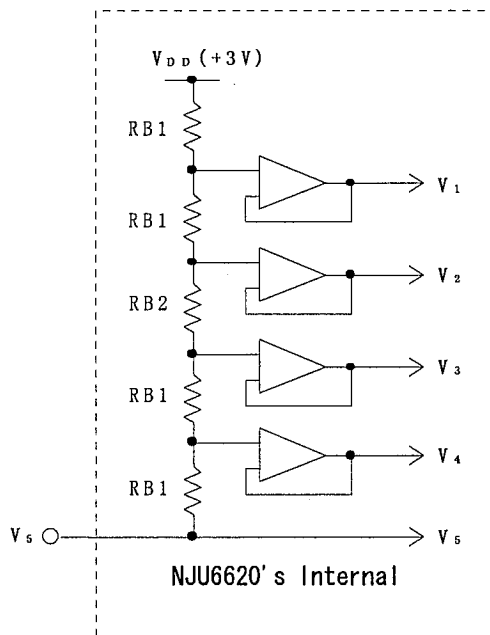

• Bus timing characteristics (VDD = 2.4 ~ 3.3V, VSS = 0V, Ta = -20 ~ +75°C)

Write operation (Write from MPU to NJU6620)

PARAMETER		SYMBOL	MIN.	MAX.	CONDITION	UNIT
Enable cycle time		t_{CYCE}	1	—	fig.1	μs
Enable pulse width	"1" level	P_{WEH}	400	—		ns
Enable rise time, fall time		t_{Er}, t_{Ef}	—	20		
Set up time	RS, R/W, E	t_{AS}	200	—		
Address hold time		t_{AH}	200	—		
Data set up time		t_{DSW}	200	—		
Data hold Time		t_{H}	200	—		

Timing Characteristics (Write operation)

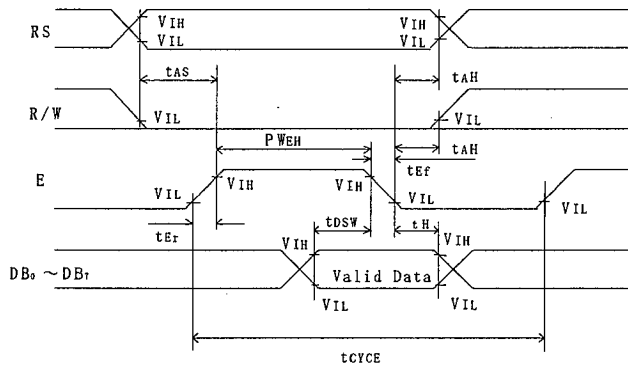

fig.1

Read operation (Read from NJU6620 to MPU)

PARAMETER		SYMBOL	MIN.	MAX.	CONDITION	UNIT
Enable cycle time		t_{CYCE}	1	—	fig. 2	μs
Enable pulse width	"1" level	P_{WEH}	750	—		ns
Enable rise time, fall time		t_{Er}, t_{Ef}	—	20		
Set up time	RS, R/W, E	t_{AS}	200	—		
Address hold time		t_{AH}	200	—		
Data delay time		t_{DDR}	—	750		
Data hold time		t_{DHR}	200	—		

Load Condition of DB0 to DB7 : $CL=100pF$

Timing Characteristics (Read operation)

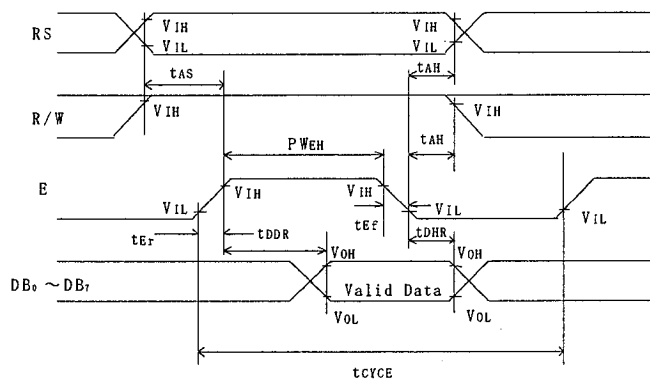

fig. 2

• Serial Interface Sequence

($V_{DD}=2.4 \sim 3.3V$, $V_{SS}=0V$, $T_a=-20 \sim +75^\circ C$)

PARAMETER		SYMBOL	MIN.	MAX.	CONDITION	UNIT
Serial clock cycle time		t_{CYCE}	1	—	fig. 3	μs
Serial clock width	"1" level	t_{SCH}	300	—		ns
	"0" level	t_{SCL}	700	—		
Serial clock rise and fall Time		t_{SCR}, t_{SCF}	—	20		
Chip select pulse width		PW_{CS}	500	—		
Chip select set up time		t_{CSU}	200	—		
Chip select hold time		t_{CH}	200	—		
Chip Select rise and fall Time		t_{CSR}, t_{CSF}	—	20		
Set up time	RS, R/W - CS	t_{AS}	200	—		
Address hold time	CS - RS, R/W	t_{AH}	200	—		
Serial input data set up time		t_{SISU}	200	—		
Serial input data hold time		t_{SIH}	200	—		
Serial output data delay time		t_{SOD}	—	700		
Serial output data hold time		t_{SOH}	200	—		

Serial Interface

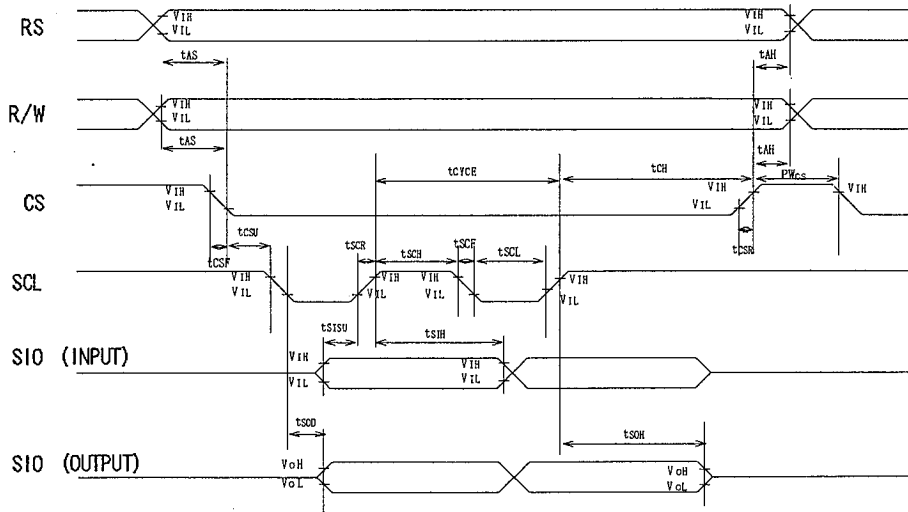
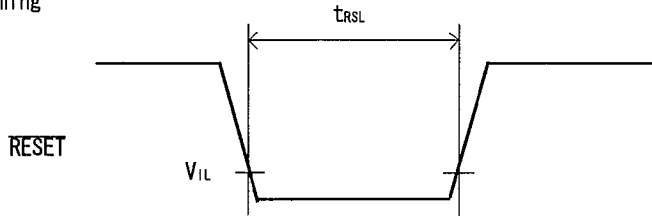

fig. 3

• The Input Condition when using the Hardware Reset Circuit

Input timing



PARAMETER	SYMBOL	CONDITION	MIN	TYP	MAX	UNIT
Reset input "0" level width	t_{RSL}	$f_{osc}=212kHz$	1.2	—	—	ms

• Power Supply Condition when using the internal initialization circuit ($T_a = -20 \sim +75^\circ C$)

PARAMETER	SYMBOL	CONDITION	MIN	TYP	MAX	UNIT
Power supply rise time	t_{rDD}	—	0.1	—	5	ms
Power supply OFF time	t_{OFF}	—	1	—	—	ms

Since the internal initialization circuits will not operate normally unless the above conditions are met, in such a case initialize by instruction. (Refer to initialization by the instruction)

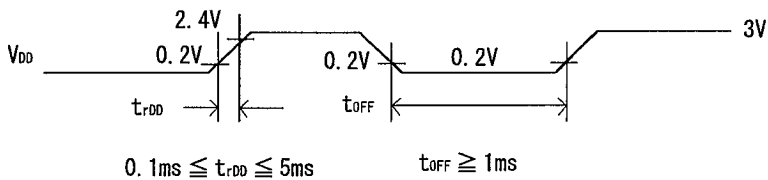

t_{OFF} specifies the power off time in a short period off or cyclical on/off.

■ LCD DRIVING WAVE FORM

1/36 Duty Driving

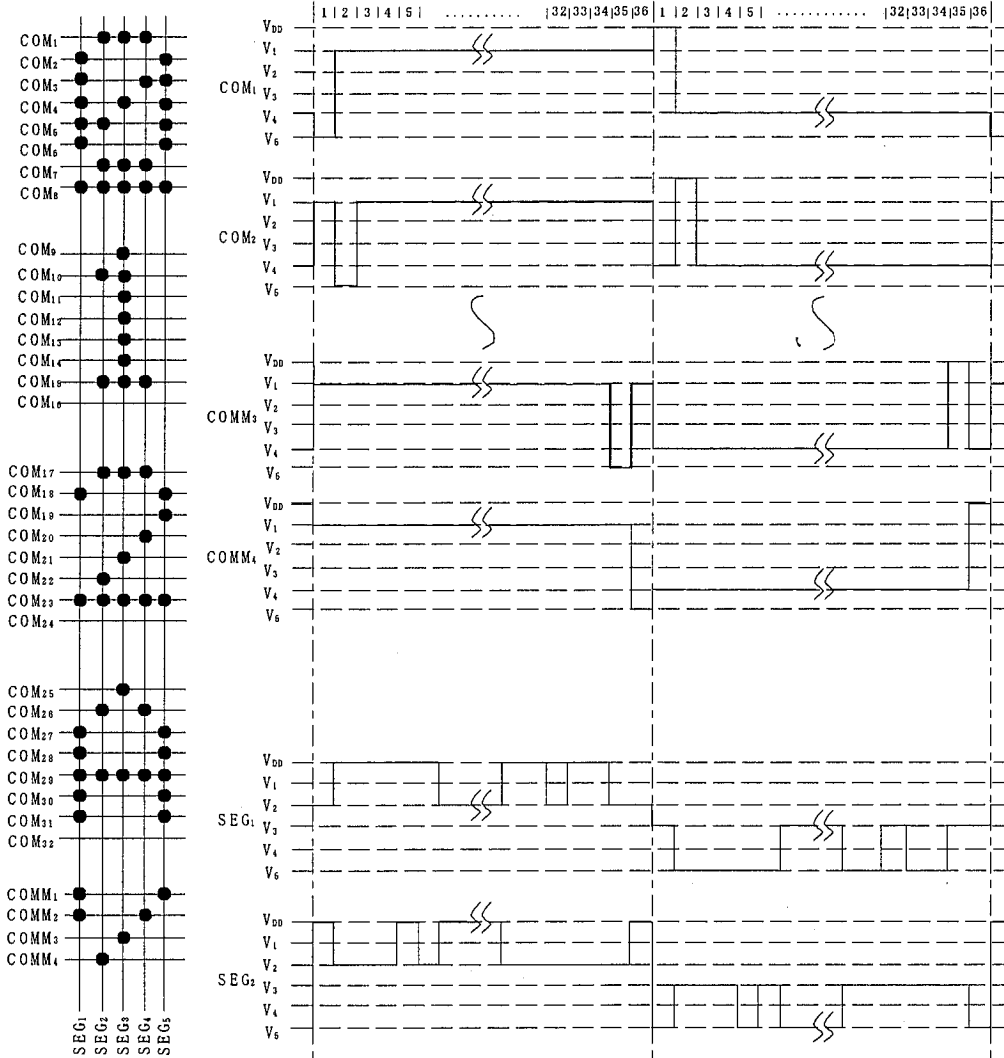

■ APPLICATION CIRCUITS (2)

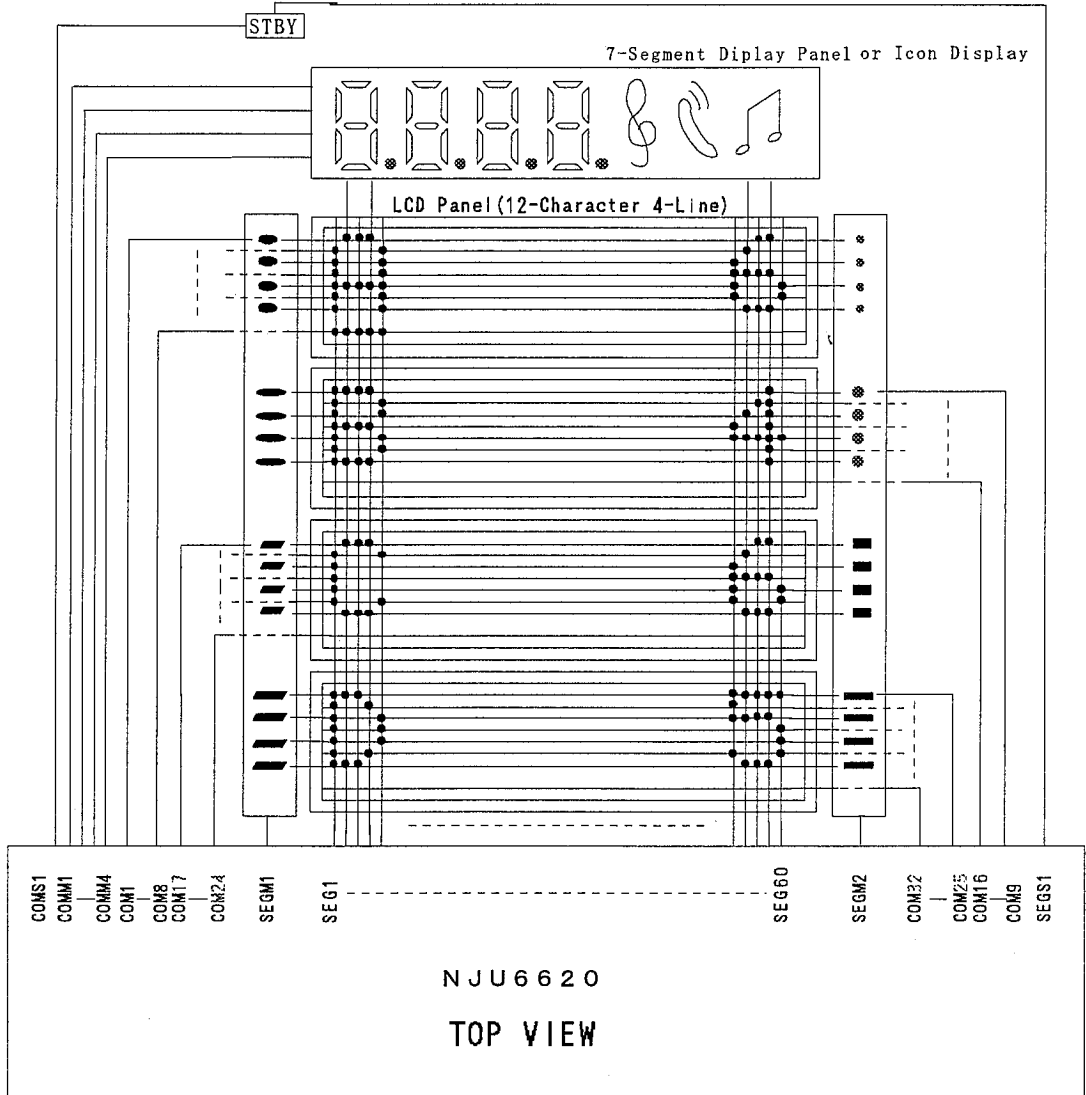

12-character 4-line Display Example
(The terminal description is "Mode B".)

MEMO

[CAUTION]

The specifications on this databook are only given for information, without any guarantee as regards either mistakes or omissions. The application circuits in this databook are described only to show representative usages of the product and not intended for the guarantee or permission of any right including the industrial rights.