



LOW SKEW, 1-TO-10, DIFFERENTIAL-TO-2.5V, 3.3V LVPECL/ECL FANOUT BUFFER

ICS853111B

GENERAL DESCRIPTION



The ICS853111B is a low skew, high performance 1-to-10 Differential-to-2.5V/3.3V LVPECL/ECL Fanout Buffer and a member of the HiPerClockS™ family of High Performance Clock Solutions from ICS. The ICS853111B is characterized to operate from either a 2.5V or a 3.3V power supply. Guaranteed output and part-to-part skew characteristics make the ICS853111B ideal for those clock distribution applications demanding well defined performance and repeatability.

FEATURES

- Ten differential 2.5V/3.3V LVPECL / ECL outputs
- Two selectable differential input pairs
- PCLKx, nPCLKx pairs can accept the following differential input levels: LVPECL, LVDS, CML, SSTL
- Maximum output frequency: >3GHz
- Translates any single ended input signal to 3.3V LVPECL levels with resistor bias on nPCLK input
- Output skew: 20ps (typical)
- Part-to-part skew: 85ps (typical)
- Propagation delay: 495ps (typical)
- Jitter, RMS: < 0.03ps (typical)
- LVPECL mode operating voltage supply range: $V_{CC} = 2.375V$ to $3.8V$, $V_{EE} = 0V$
- ECL mode operating voltage supply range: $V_{CC} = 0V$, $V_{EE} = -3.8V$ to $-2.375V$
- $-40^{\circ}C$ to $85^{\circ}C$ ambient operating temperature
- Available in both standard (RoHS 5) and lead-free (RoHS 6) packages

BLOCK DIAGRAM

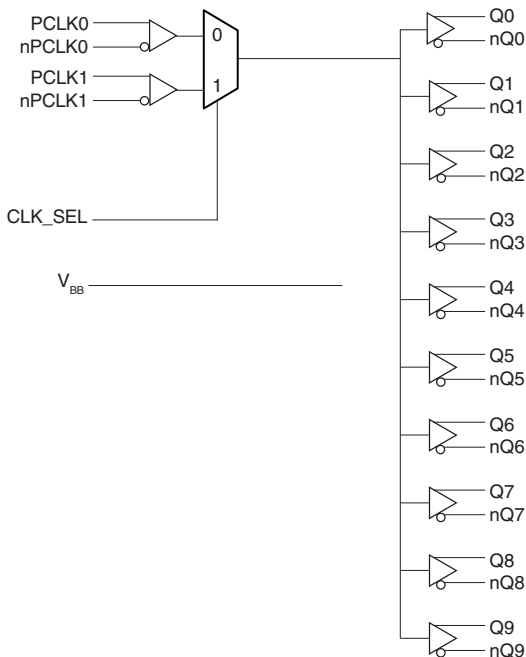

PIN ASSIGNMENT

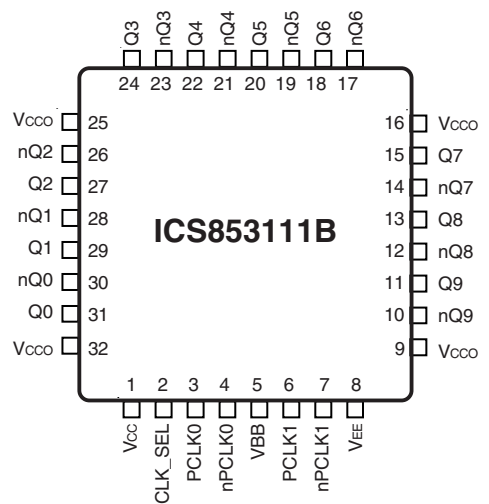

32-Lead TQFP, E-PAD
7mm x 7mm x 1.0mm package body
Y Package
Top View

TABLE 1. PIN DESCRIPTIONS

Number	Name	Type		Description
1	V _{CC}	Power		Positive supply pin.
2	CLK_SEL	Input	Pulldown	Clock select input. When HIGH, selects PCLK1, nPCLK1 inputs. When LOW, selects PCLK0, nPCLK0 inputs. LVCMOS / LVTTTL interface levels.
3	PCLK0	Input	Pulldown	Non-inverting differential clock input.
4	nPCLK0	Input	Pullup/Pulldown	Inverting differential LVPECL clock input. V _{CC} /2 default when left floating.
5	V _{BB}	Output		Bias voltage.
6	PCLK1	Input	Pulldown	Non-inverting differential clock input.
7	nPCLK1	Input	Pullup/Pulldown	Inverting differential LVPECL clock input. V _{CC} /2 default when left floating.
8	V _{EE}	Power		Negative supply pin.
9, 16, 25, 32	V _{CCO}	Power		Output supply pins.
10, 11	nQ9, Q9	Output		Differential output pair. LVPECL interface levels.
12, 13	nQ8, Q8	Output		Differential output pair. LVPECL interface levels.
14, 15	nQ7, Q7	Output		Differential output pair. LVPECL interface levels.
17, 18	nQ6, Q6	Output		Differential output pair. LVPECL interface levels.
19, 20	nQ5, Q5	Output		Differential output pair. LVPECL interface levels.
21, 22	nQ4, Q4	Output		Differential output pair. LVPECL interface levels.
23, 24	nQ3, Q3	Output		Differential output pair. LVPECL interface levels.
26, 27	nQ2, Q2	Output		Differential output pair. LVPECL interface levels.
28, 29	nQ1, Q1	Output		Differential output pair. LVPECL interface levels.
30, 31	nQ0, Q0	Output		Differential output pair. LVPECL interface levels.

NOTE: Pullup and Pulldown refer to internal input resistors. See Table 2, Pin Characteristics, for typical values.

TABLE 2. PIN CHARACTERISTICS

Symbol	Parameter	Test Conditions	Minimum	Typical	Maximum	Units
R _{PULLDOWN}	Input Pulldown Resistor			75		kΩ
R _{VCC/2}	Pullup/Pulldown Resistors			50		kΩ

TABLE 3A. CLOCK INPUT FUNCTION TABLE

Inputs		Outputs		Input to Output Mode	Polarity
PCLKx	nPCLKx	Q0:Q9	nQ0:Q9		
0	1	LOW	HIGH	Differential to Differential	Non Inverting
1	0	HIGH	LOW	Differential to Differential	Non Inverting
0	Biased; NOTE 1	LOW	HIGH	Single Ended to Differential	Non Inverting
1	Biased; NOTE 1	HIGH	LOW	Single Ended to Differential	Non Inverting
Biased; NOTE 1	0	HIGH	LOW	Single Ended to Differential	Inverting
Biased; NOTE 1	1	LOW	HIGH	Single Ended to Differential	Inverting

NOTE 1: Please refer to the Application Information, "Wiring the Differential Input to Accept Single Ended Levels".

TABLE 3B. CONTROL INPUT FUNCTION TABLE

Inputs	
CLK_SEL	Selected Source
0	PCLK0, nPCLK0
1	PCLK1, nPCLK1

ABSOLUTE MAXIMUM RATINGS

Supply Voltage, V_{CC}	4.6V (LVPECL mode, $V_{EE} = 0$)
Negative Supply Voltage, V_{EE}	-4.6V (ECL mode, $V_{CC} = 0$)
Inputs, V_i (LVPECL mode)	-0.5V to $V_{CC} + 0.5$ V
Inputs, V_i (ECL mode)	0.5V to $V_{EE} - 0.5$ V
Outputs, I_o	
Continuous Current	50mA
Surge Current	100mA
V_{BB} Sink/Source, I_{BB}	± 0.5 mA
Operating Temperature Range, T_A	-40°C to +85°C
Storage Temperature, T_{STG}	-65°C to 150°C
Package Thermal Impedance, θ_{JA}	49.5°C/W (0 lfpm) (Junction-to-Ambient)

NOTE: Stresses beyond those listed under Absolute Maximum Ratings may cause permanent damage to the device. These ratings are stress specifications only. Functional operation of product at these conditions or any conditions beyond those listed in the *DC Characteristics* or *AC Characteristics* is not implied. Exposure to absolute maximum rating conditions for extended periods may affect product reliability.

TABLE 4A. POWER SUPPLY DC CHARACTERISTICS, $V_{CC} = 2.375$ V TO 3.8V; $V_{EE} = 0$ V

Symbol	Parameter	Test Conditions	Minimum	Typical	Maximum	Units
V_{CC}	Positive Supply Voltage		2.375	3.3	3.8	V
I_{EE}	Power Supply Current			120		mA

TABLE 4B. LVPECL DC CHARACTERISTICS, $V_{CC} = 3.3$ V; $V_{EE} = 0$ V

Symbol	Parameter	-40°C			25°C			85°C			Units
		Min	Typ	Max	Min	Typ	Max	Min	Typ	Max	
V_{OH}	Output High Voltage; NOTE 1	2.175	2.275	2.38	2.225	2.295	2.37	2.295	2.33	2.365	V
V_{OL}	Output Low Voltage; NOTE 1	1.405	1.545	1.68	1.425	1.52	1.615	1.44	1.535	1.63	V
V_{IH}	Input High Voltage(Single-Ended)	2.075		2.36	2.075		2.36	2.075		2.36	V
V_{IL}	Input Low Voltage(Single-Ended)	1.43		1.765	1.43		1.765	1.43		1.765	V
V_{BB}	Output Voltage Reference; NOTE 2	1.86		1.98	1.86		1.98	1.86		1.98	V
V_{PP}	Peak-to-Peak Input Voltage	150	800	1200	150	800	1200	150	800	1200	mV
V_{CMR}	Input High Voltage Common Mode Range; NOTE 3, 4	1.2		3.3	1.2		3.3	1.2		3.3	V
I_{IH}	Input High Current	PCLK0, PCLK1 nPCLK0, nPCLK1		150			150			150	μ A
I_{IL}	Input Low Current	PCLK0, PCLK1		-10			-10			-10	μ A
		nPCLK0, nPCLK1		-150			-150			-150	μ A

Input and output parameters vary 1:1 with V_{CC} . V_{EE} can vary +0.925V to -0.5V.

NOTE 1: Outputs terminated with 50 Ω to $V_{CCO} - 2$ V.

NOTE 2: Single-ended input operation is limited. $V_{CC} \geq 3$ V in LVPECL mode.

NOTE 3: Common mode voltage is defined as V_{IH} .

NOTE 4: For single-ended applications, the maximum input voltage for PCLK0, nPCLK0 and PCLK1, nPCLK1 is $V_{CC} + 0.3$ V.

TABLE 4C. LVPECL DC CHARACTERISTICS, $V_{CC} = 2.5V$; $V_{EE} = 0V$

Symbol	Parameter	-40°C			25°C			85°C			Units
		Min	Typ	Max	Min	Typ	Max	Min	Typ	Max	
V_{OH}	Output High Voltage; NOTE 1	1.375	1.475	1.58	1.425	1.495	1.57	1.495	1.53	1.565	V
V_{OL}	Output Low Voltage; NOTE 1	0.605	0.745	0.88	0.625	0.72	0.815	0.64	0.735	0.83	V
V_{IH}	Input High Voltage(Single-Ended)	1.275		1.56	1.275		1.56	1.275		1.56	V
V_{IL}	Input Low Voltage(Single-Ended)	0.63		0.965	0.63		0.965	0.63		0.965	V
V_{PP}	Peak-to-Peak Input Voltage	150	800	1200	150	800	1200	150	800	1200	mV
V_{CMR}	Input High Voltage Common Mode Range; NOTE 3, 4	1.2		2.5	1.2		2.5	1.2		2.5	V
I_{IH}	Input High Current	PCLK0, PCLK1 nPCLK0, nPCLK1		150			150			150	μA
I_{IL}	Input Low Current	PCLK0, PCLK1		-10			-10			-10	μA
		nPCLK0, nPCLK1		-150			-150			-150	μA

Input and output parameters vary 1:1 with V_{CC} . V_{EE} can vary +0.925V to -0.5V.

NOTE 1: Outputs terminated with 50 Ω to $V_{CC} - 2V$.

NOTE 2: Single-ended input operation is limited. $V_{CC} \geq 3V$ in LVPECL mode.

NOTE 3: Common mode voltage is defined as V_{IH} .

NOTE 4: For single-ended applications, the maximum input voltage for PCLK0, nPCLK0 and PCLK1, nPCLK1 is $V_{CC} + 0.3V$.

TABLE 4D. ECL DC CHARACTERISTICS, $V_{CC} = 0V$; $V_{EE} = -3.8V$ TO $-2.375V$

Symbol	Parameter	-40°C			25°C			85°C			Units
		Min	Typ	Max	Min	Typ	Max	Min	Typ	Max	
V_{OH}	Output High Voltage; NOTE 1	-1.125	-1.025	-0.92	-1.075	-1.005	-0.93	-1.005	-0.97	-0.935	V
V_{OL}	Output Low Voltage; NOTE 1	-1.895	-1.755	-1.62	-1.875	-1.78	-1.685	-1.86	-1.765	-1.67	V
V_{IH}	Input High Voltage(Single-Ended)	-1.225		-0.94	-1.225		-0.94	-1.225		-0.94	V
V_{IL}	Input Low Voltage(Single-Ended)	-1.87		-1.535	-1.87		-1.535	-1.87		-1.535	V
V_{BB}	Output Voltage Reference; NOTE 2	-1.44		-1.32	-1.44		-1.32	-1.44		-1.32	V
V_{PP}	Peak-to-Peak Input Voltage	150	800	1200	150	800	1200	150	800	1200	mV
V_{CMR}	Input High Voltage Common Mode Range; NOTE 3, 4	$V_{EE} + 1.2V$		0	$V_{EE} + 1.2V$		0	$V_{EE} + 1.2V$		0	V
I_{IH}	Input High Current	PCLK0, PCLK1 nPCLK0, nPCLK1		150			150			150	μA
I_{IL}	Input Low Current	PCLK0, PCLK1		-10			-10			-10	μA
		nPCLK0, nPCLK1		-150			-150			-150	μA

Input and output parameters vary 1:1 with V_{CC} . V_{EE} can vary +0.925V to -0.5V.

NOTE 1: Outputs terminated with 50 Ω to $V_{CC} - 2V$.

NOTE 2: Single-ended input operation is limited. $V_{CC} \geq 3V$ in LVPECL mode.

NOTE 3: Common mode voltage is defined as V_{IH} .

NOTE 4: For single-ended applications, the maximum input voltage for PCLK0, nPCLK0 and PCLK1, nPCLK1 is $V_{CC} + 0.3V$.

TABLE 5. AC CHARACTERISTICS, $V_{CC} = 0V$; $V_{EE} = -3.8V$ TO $-2.375V$ OR $V_{CC} = 2.375$ TO $3.8V$; $V_{EE} = 0V$

Symbol	Parameter	-40°C			25°C			85°C			Units	
		Min	Typ	Max	Min	Typ	Max	Min	Typ	Max		
f_{MAX}	Output Frequency		>3			>3			>3		GHz	
t_{PD}	Propagation Delay; NOTE 1	375	475	575	395	495	595	425	530	635	ps	
$t_{sk(o)}$	Output Skew; NOTE 2, 4		20	32		20	32		20	32	ps	
$t_{sk(pp)}$	Part-to-Part Skew; NOTE 3, 4		85	150		85	150		85	150	ps	
f_{jit}	Buffer Additive Phase Jitter, RMS; refer to Additive Phase Jitter section		0.03			0.03			0.03		ps	
t_R/t_F	Output Rise/Fall Time	20% to 80%	75	150	220	80	150	215	78	150	215	ps

All parameters are measured $\leq 1GHz$ unless otherwise noted.

NOTE 1: Measured from the differential input crossing point to the differential output crossing point.

NOTE 2: Defined as skew between outputs at the same supply voltage and with equal load conditions.

Measured at the output differential cross points.

NOTE 3: Defined as skew between outputs on different devices operating at the same supply voltages and with equal load conditions. Using the same type of inputs on each device, the outputs are measured at the differential cross points.

NOTE 4: This parameter is defined in accordance with JEDEC Standard 65.

ADDITIVE PHASE JITTER

The spectral purity in a band at a specific offset from the fundamental compared to the power of the fundamental is called the ***dBc Phase Noise***. This value is normally expressed using a Phase noise plot and is most often the specified plot in many applications. Phase noise is defined as the ratio of the noise power present in a 1Hz band at a specified offset from the fundamental frequency to the power value of the fundamental. This ratio is expressed in decibels (dBm) or a ratio of the power in the 1Hz

band to the power in the fundamental. When the required offset is specified, the phase noise is called a ***dBc*** value, which simply means dBm at a specified offset from the fundamental. By investigating jitter in the frequency domain, we get a better understanding of its effects on the desired application over the entire time record of the signal. It is mathematically possible to calculate an expected bit error rate given a phase noise plot.

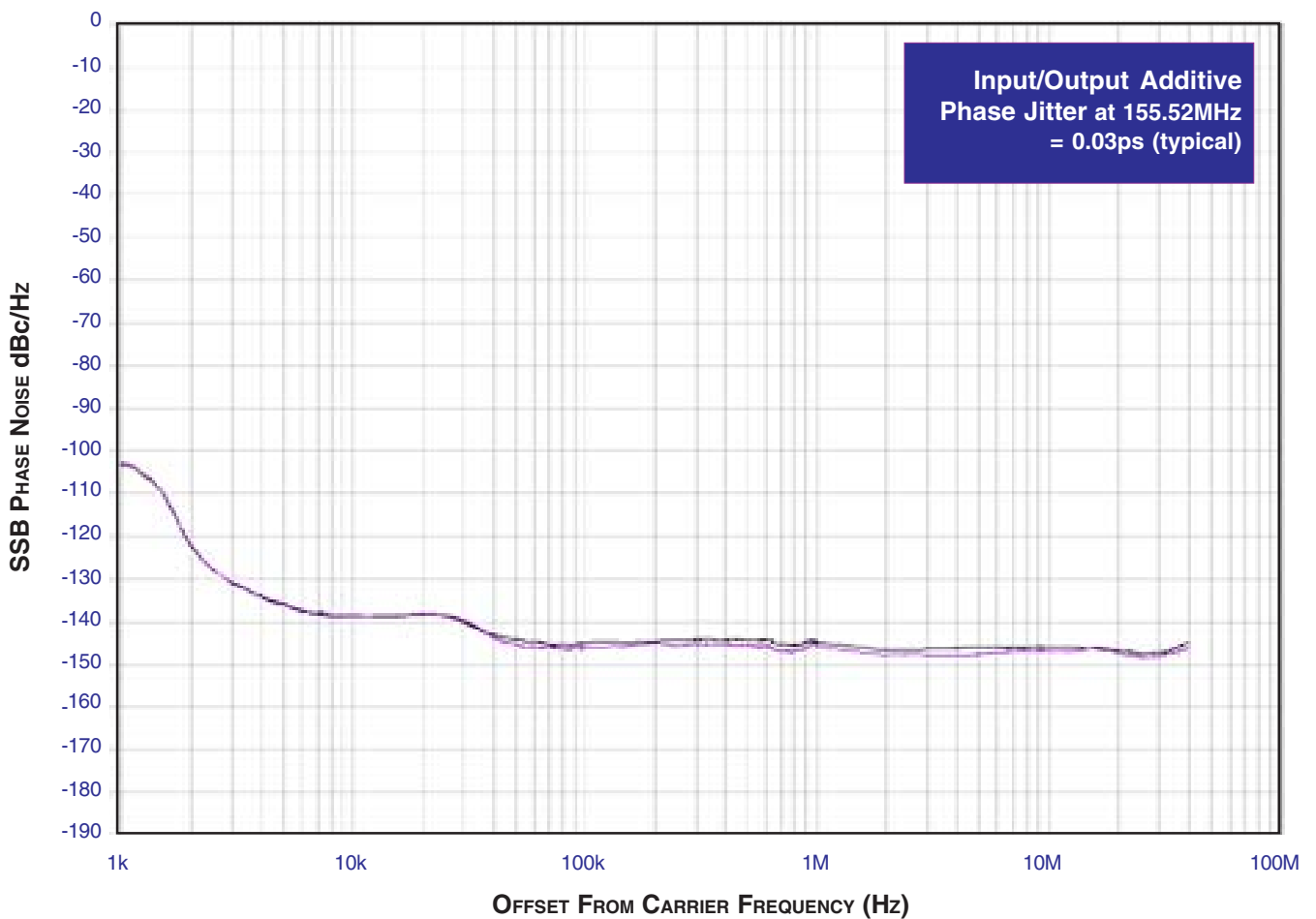

As with most timing specifications, phase noise measurements has issues relating to the limitations of the equipment. Often the noise floor of the equipment is higher than the noise floor of the device. This is illustrated above. The device meets the noise floor

of what is shown, but can actually be lower. The phase noise is dependent on the input source and measurement equipment.

PARAMETER MEASUREMENT INFORMATION

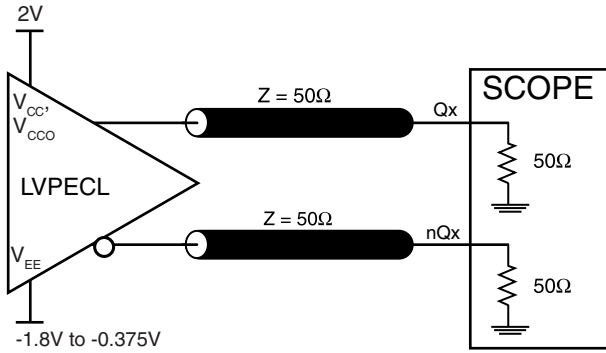

OUTPUT LOAD AC TEST CIRCUIT

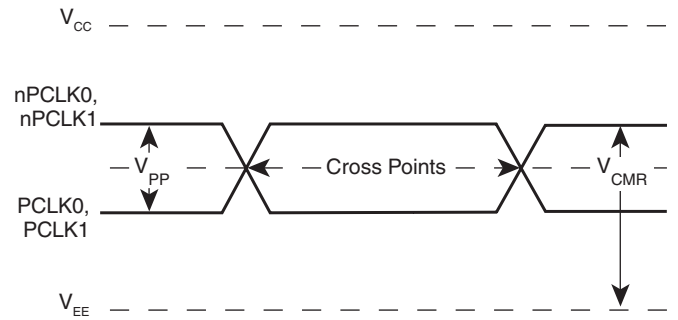

DIFFERENTIAL INPUT LEVEL

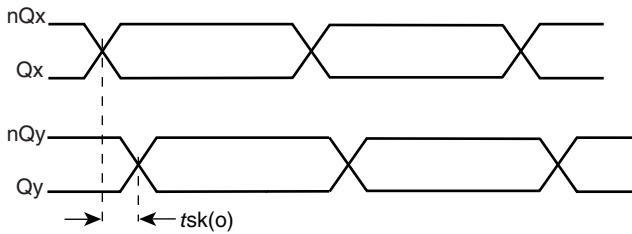

OUTPUT SKEW

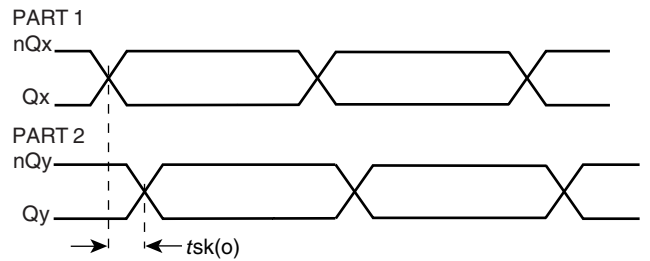

PART-TO-PART SKEW

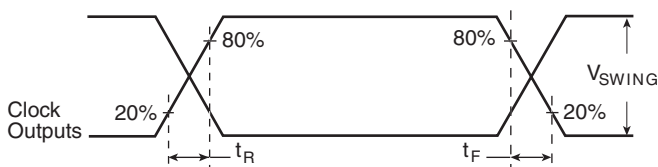

OUTPUT RISE/FALL TIME

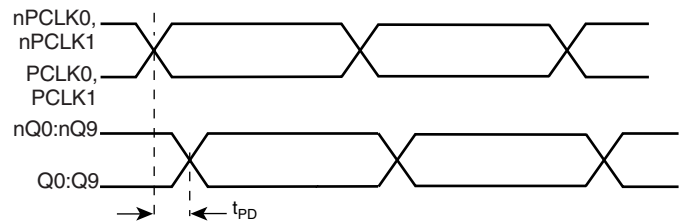

PROPAGATION DELAY

APPLICATION INFORMATION

WIRING THE DIFFERENTIAL INPUT TO ACCEPT SINGLE ENDED LVCMOS LEVELS

Figure 2A shows how the differential input can be wired to accept single ended levels. The reference voltage $V_{REF} \approx V_{CC}/2$ is generated by the bias resistors R1, R2 and C1. This bias circuit should be located as close as possible to the input pin.

of R1 and R2 might need to be adjusted to position the V_{REF} in the center of the input voltage swing. For example, if the input clock swing is only 2.5V and $V_{CC} = 3.3V$, V_{REF} should be 1.25V and $R2/R1 = 0.609$.

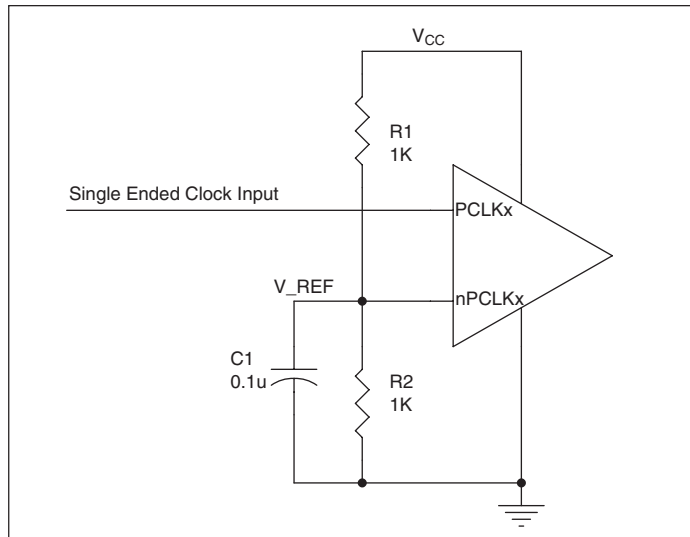

FIGURE 2A. SINGLE ENDED SIGNAL DRIVING DIFFERENTIAL INPUT

WIRING THE DIFFERENTIAL INPUT TO ACCEPT SINGLE ENDED LVPECL LEVELS

Figure 2B shows an example of the differential input that can be wired to accept single ended LVPECL levels. The reference voltage level V_{BB} generated from the device is connected to the

negative input. The C1 capacitor should be located as close as possible to the input pin.

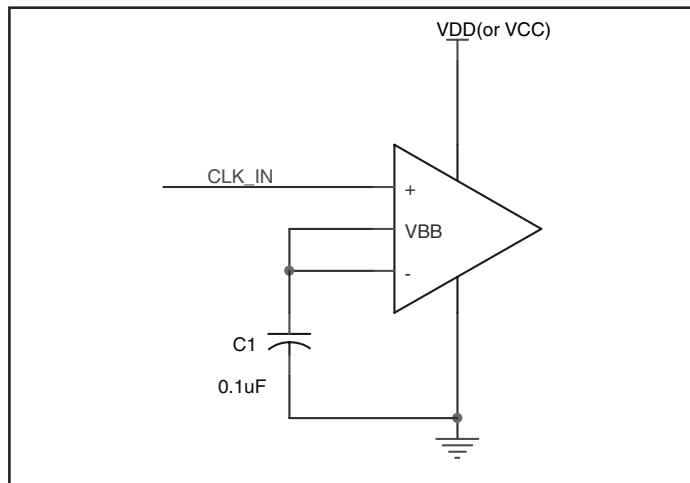

FIGURE 2B. SINGLE ENDED LVPECL SIGNAL DRIVING DIFFERENTIAL INPUT

LVPECL CLOCK INPUT INTERFACE

The PCLK /nPCLK accepts LVPECL, CML, SSTL and other differential signals. Both V_{SWING} and V_{OH} must meet the V_{PP} and V_{CMR} input requirements. *Figures 3A to 3E* show interface examples for the HiPerClockS PCLK/nPCLK input driven by the most common driver types. The input interfaces suggested

here are examples only. If the driver is from another vendor, use their termination recommendation. Please consult with the vendor of the driver component to confirm the driver termination requirements.

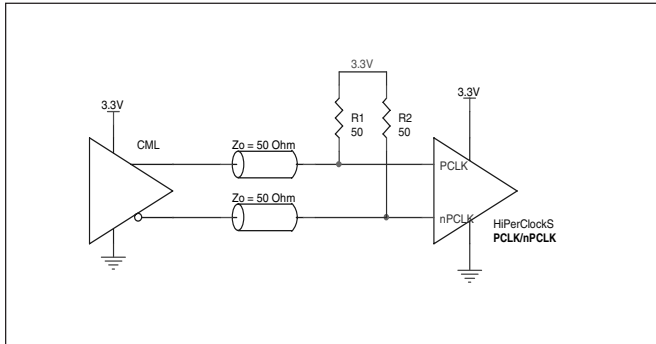

FIGURE 4A. HiPerClockS PCLK/nPCLK INPUT DRIVEN BY A CML DRIVER

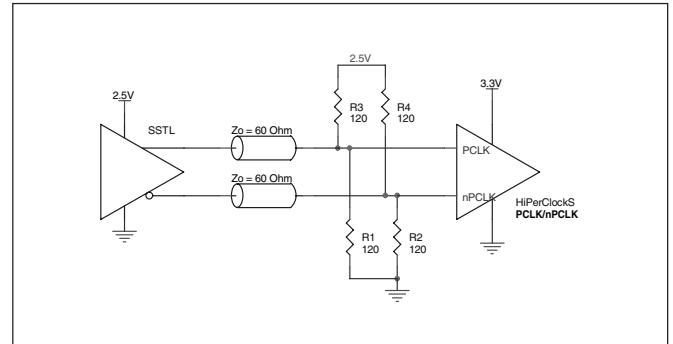

FIGURE 3B. HiPerClockS PCLK/nPCLK INPUT DRIVEN BY AN SSTL DRIVER

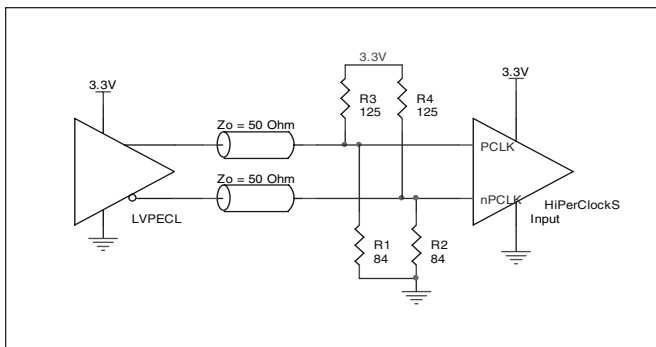

FIGURE 3C. HiPerClockS PCLK/nPCLK INPUT DRIVEN BY A 3.3V LVPECL DRIVER

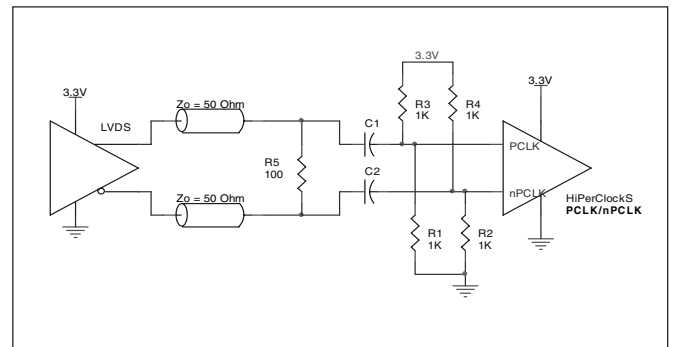

FIGURE 3D. HiPerClockS PCLK/nPCLK INPUT DRIVEN BY A 3.3V LVDS DRIVER

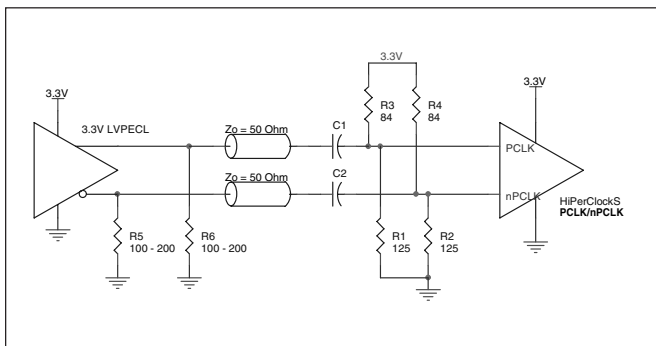

FIGURE 3E. HiPerClockS PCLK/nPCLK INPUT DRIVEN BY A 3.3V LVPECL DRIVER WITH AC COUPLE

RECOMMENDATIONS FOR UNUSED INPUT AND OUTPUT PINS

INPUTS

PCLK/nPCLK INPUTS

For applications not requiring the use of a differential input, both the PCLK and nPCLK pins can be left floating. Though not required, but for additional protection, a 1k Ω resistor can be tied from PCLK to ground.

OUTPUTS

LVPECL OUTPUTS

All unused LVPECL outputs can be left floating. We recommend that there is no trace attached. Both sides of the differential output pair should either be left floating or terminated.

TERMINATION FOR 3.3V LVPECL OUTPUTS

The clock layout topology shown below is a typical termination for LVPECL outputs. The two different layouts mentioned are recommended only as guidelines.

FOUT and nFOUT are low impedance follower outputs that generate ECL/LVPECL compatible outputs. Therefore, terminating resistors (DC current path to ground) or current sources must be used for functionality. These outputs are designed to drive 50 Ω transmission lines. Matched imped-

ance techniques should be used to maximize operating frequency and minimize signal distortion. *Figures 4A and 4B* show two different layouts which are recommended only as guidelines. Other suitable clock layouts may exist and it would be recommended that the board designers simulate to guarantee compatibility across all printed circuit and clock component process variations.

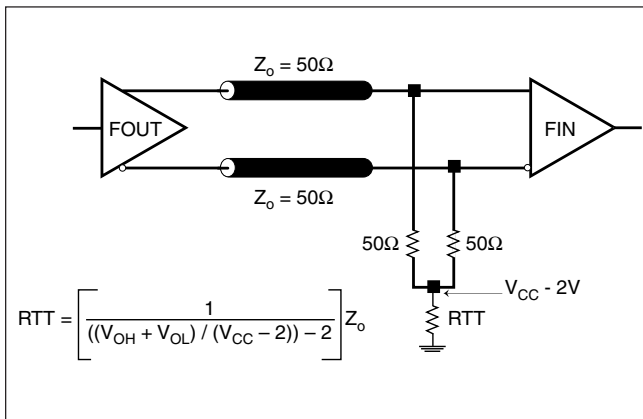

FIGURE 4A. LVPECL OUTPUT TERMINATION

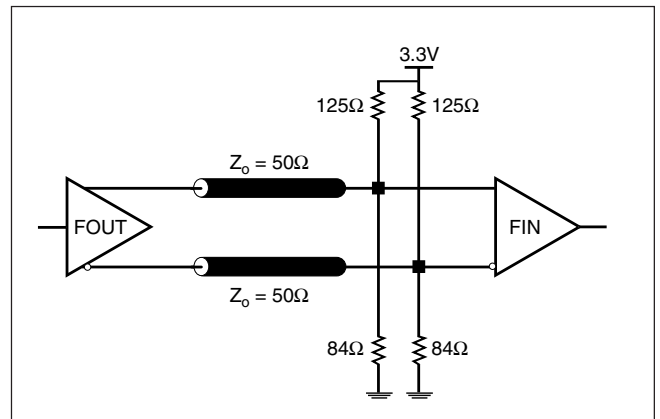

FIGURE 4B. LVPECL OUTPUT TERMINATION

TERMINATION FOR 2.5V LVPECL OUTPUT

Figure 5A and Figure 5B show examples of termination for 2.5V LVPECL driver. These terminations are equivalent to terminating

50Ω to $V_{CC} - 2V$. For $V_{CC} = 2.5V$, the $V_{CC} - 2V$ is very close to ground level. The $R3$ in Figure 5B can be eliminated and the termination is shown in Figure 5C.

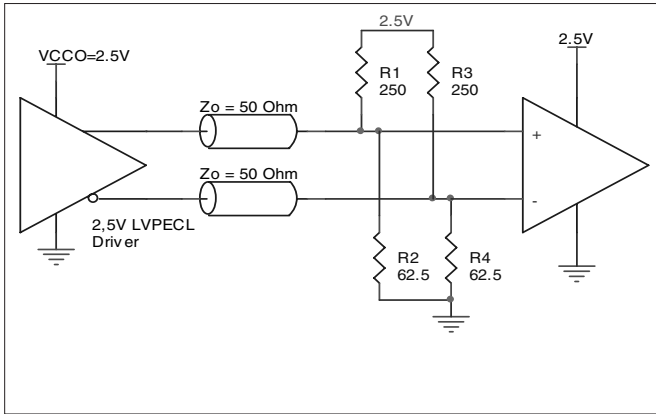

FIGURE 5A. 2.5V LVPECL DRIVER TERMINATION EXAMPLE

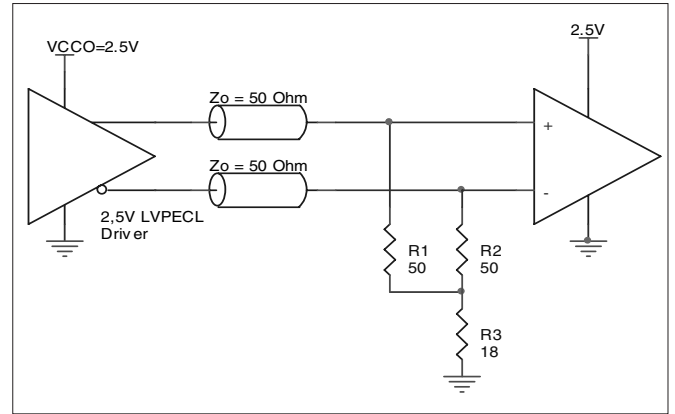

FIGURE 5B. 2.5V LVPECL DRIVER TERMINATION EXAMPLE

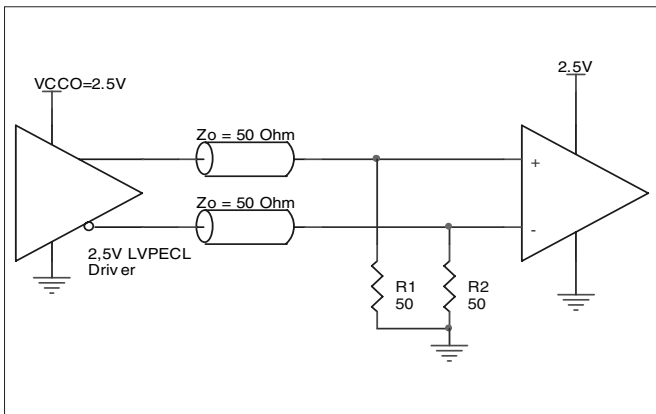

FIGURE 5C. 2.5V LVPECL TERMINATION EXAMPLE

SCHEMATIC EXAMPLE

This application note provides general design guide using ICS853111B LVPECL buffer. Figure 6 shows a schematic example of the ICS853111B LVPECL clock buffer. In this example, the

input is driven by an LVPECL driver. CLK_SEL is set at logic high to select PCLK0/nPCLK0 input.

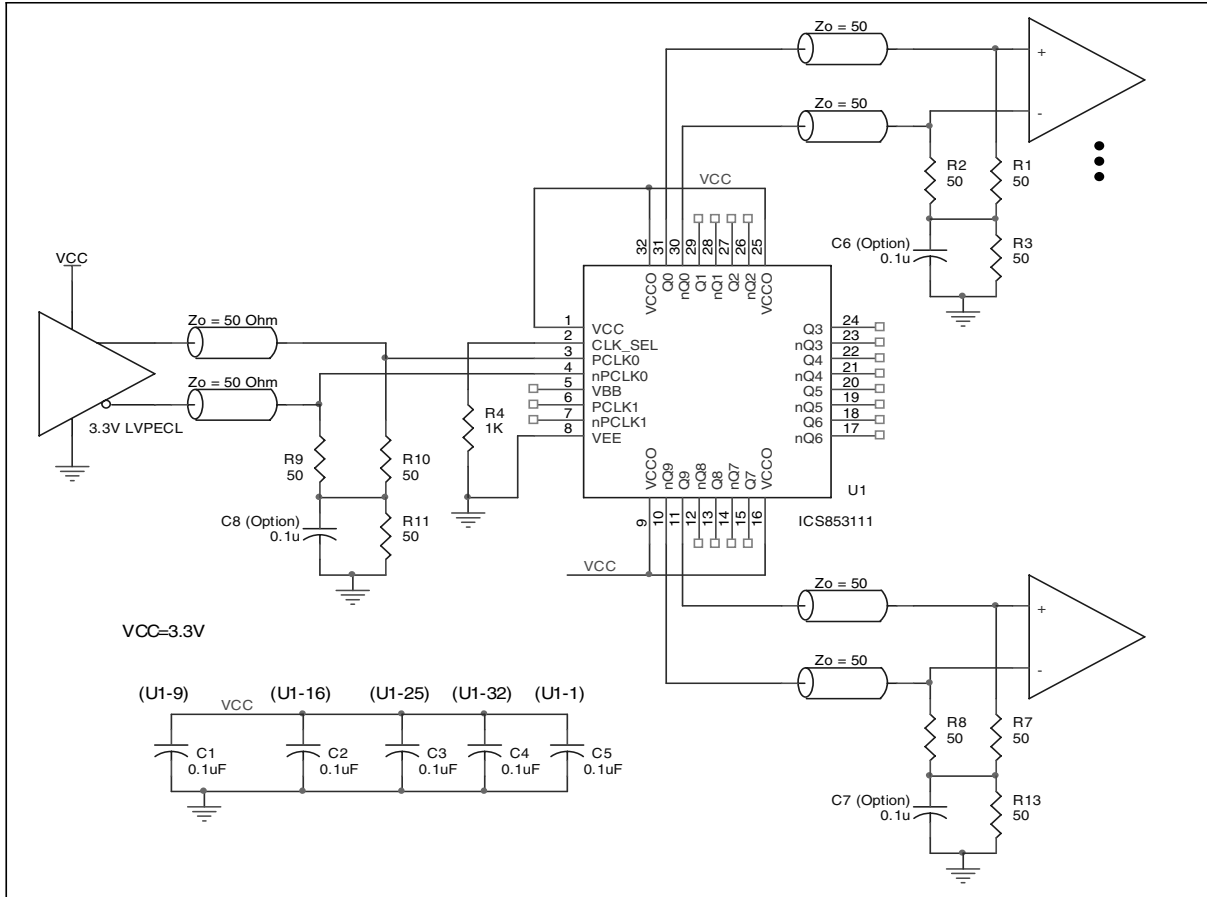

FIGURE 6. EXAMPLE ICS853111B LVPECL CLOCK OUTPUT BUFFER SCHEMATIC

THERMAL RELEASE PATH

The expose metal pad provides heat transfer from the device to the P.C. board. The expose metal pad is ground pad connected to ground plane through thermal via. The exposed pad on the device to the exposed metal pad on the PCB is contacted through

solder as shown in *Figure 7*. For further information, please refer to the Application Note on Surface Mount Assembly of Amkor's Thermally/Electrically Enhance Leadframe Base Package, Amkor Technology.

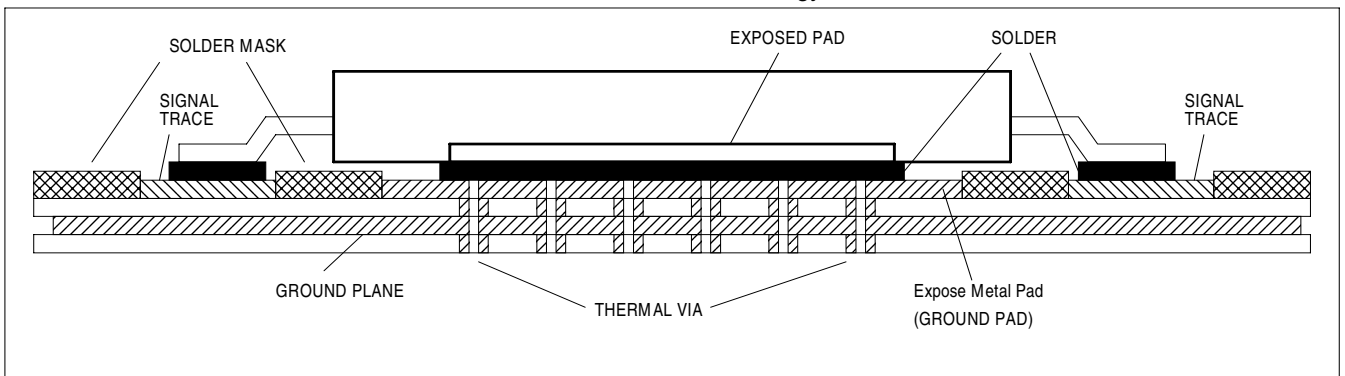

FIGURE 7. P.C. BOARD FOR EXPOSED PAD THERMAL RELEASE PATH EXAMPLE

POWER CONSIDERATIONS

This section provides information on power dissipation and junction temperature for the ICS853111B. Equations and example calculations are also provided.

1. Power Dissipation.

The total power dissipation for the ICS853111B is the sum of the core power plus the power dissipated in the load(s). The following is the power dissipation for $V_{CC} = 3.8V$, which gives worst case results.

NOTE: Please refer to Section 3 for details on calculating power dissipated in the load.

- Power (core)_{MAX} = $V_{CC_MAX} * I_{EE_MAX} = 3.8V * 120mA = 456mW$
- Power (outputs)_{MAX} = **30.94mW/Loaded Output pair**
If all outputs are loaded, the total power is $10 * 30.94mW = 309.4mW$

$$\text{Total Power}_{_MAX} (3.8V, \text{ with all outputs switching}) = 456mW + 309.4mW = \mathbf{765.4mW}$$

2. Junction Temperature.

Junction temperature, T_j , is the temperature at the junction of the bond wire and bond pad and directly affects the reliability of the device. The maximum recommended junction temperature for HiPerClockS™ devices is 125°C.

The equation for T_j is as follows: $T_j = \theta_{JA} * Pd_total + T_A$

T_j = Junction Temperature

θ_{JA} = junction-to-Ambient Thermal Resistance

Pd_total = Total Device Power Dissipation (example calculation is in section 1 above)

T_A = Ambient Temperature

In order to calculate junction temperature, the appropriate junction-to-ambient thermal resistance θ_{JA} must be used. Assuming a moderate air flow of 200 linear feet per minute and a multi-layer board, the appropriate value is 43.8°C/W per Table 6 below.

Therefore, T_j for an ambient temperature of 70°C with all outputs switching is:

$$70^\circ\text{C} + 0.765W * 43.8^\circ\text{C/W} = 118.5^\circ\text{C}. \text{ This is below the limit of } 125^\circ\text{C}.$$

This calculation is only an example. T_j will obviously vary depending on the number of loaded outputs, supply voltage, air flow, and the type of board (single layer or multi-layer).

TABLE 6. THERMAL RESISTANCE θ_{JA} FOR 32-PIN TQFP, E-PAD FORCED CONVECTION

θ_{JA} by Velocity (Linear Feet per Minute)			
	0	200	500
Single-Layer PCB, JEDEC Standard Test Boards	69.3°C/W	57.8°C/W	52.1°C/W
Multi-Layer PCB, JEDEC Standard Test Boards	49.5°C/W	43.8°C/W	41.3°C/W

NOTE: Most modern PCB designs use multi-layered boards. The data in the second row pertains to most designs.

3. Calculations and Equations.

The purpose of this section is to derive the power dissipated into the load.

LVPECL output driver circuit and termination are shown in *Figure 7*.

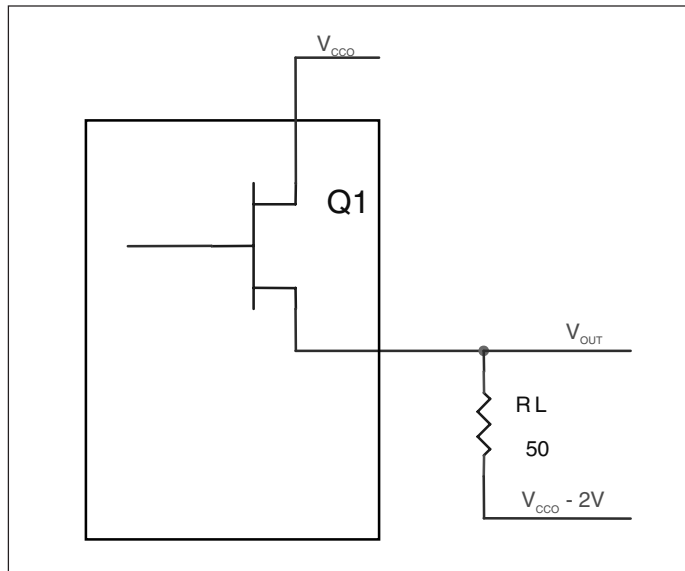

FIGURE 7. LVPECL DRIVER CIRCUIT AND TERMINATION

To calculate worst case power dissipation into the load, use the following equations which assume a 50Ω load, and a termination voltage of $V_{CCO} - 2V$.

- For logic high, $V_{OUT} = V_{OH_MAX} = V_{CCO_MAX} - 0.935V$

$$(V_{CCO_MAX} - V_{OH_MAX}) = 0.935V$$

- For logic low, $V_{OUT} = V_{OL_MAX} = V_{CCO_MAX} - 1.67V$

$$(V_{CCO_MAX} - V_{OL_MAX}) = 1.67V$$

$$Pd_H = [(V_{OH_MAX} - (V_{CCO_MAX} - 2V))/R_L] * (V_{CCO_MAX} - V_{OH_MAX}) = [(2V - (V_{CCO_MAX} - V_{OH_MAX}))/R_L] * (V_{CCO_MAX} - V_{OH_MAX}) = [(2V - 0.935V)/50\Omega] * 0.935V = 19.92mW$$

$$Pd_L = [(V_{OL_MAX} - (V_{CCO_MAX} - 2V))/R_L] * (V_{CCO_MAX} - V_{OL_MAX}) = [(2V - (V_{CCO_MAX} - V_{OL_MAX}))/R_L] * (V_{CCO_MAX} - V_{OL_MAX}) = [(2V - 1.67V)/50\Omega] * 1.67V = 11.02mW$$

$$\text{Total Power Dissipation per output pair} = Pd_H + Pd_L = 30.94mW$$

RELIABILITY INFORMATION

TABLE 7. θ_{JA} vs. AIR FLOW TABLE FOR 32 LEAD TQFP, E-PAD

	θ_{JA} by Velocity (Linear Feet per Minute)		
	0	200	500
Single-Layer PCB, JEDEC Standard Test Boards	69.3°C/W	57.8°C/W	52.1°C/W
Multi-Layer PCB, JEDEC Standard Test Boards	49.5°C/W	43.8°C/W	41.3°C/W

NOTE: Most modern PCB designs use multi-layered boards. The data in the second row pertains to most designs.

TRANSISTOR COUNT

The transistor count for ICS853111B is: 1340

Pin compatible with MC100EP111 and MC100LVEP111

PACKAGE OUTLINE - Y SUFFIX FOR 32 LEAD TQFP, E-PAD

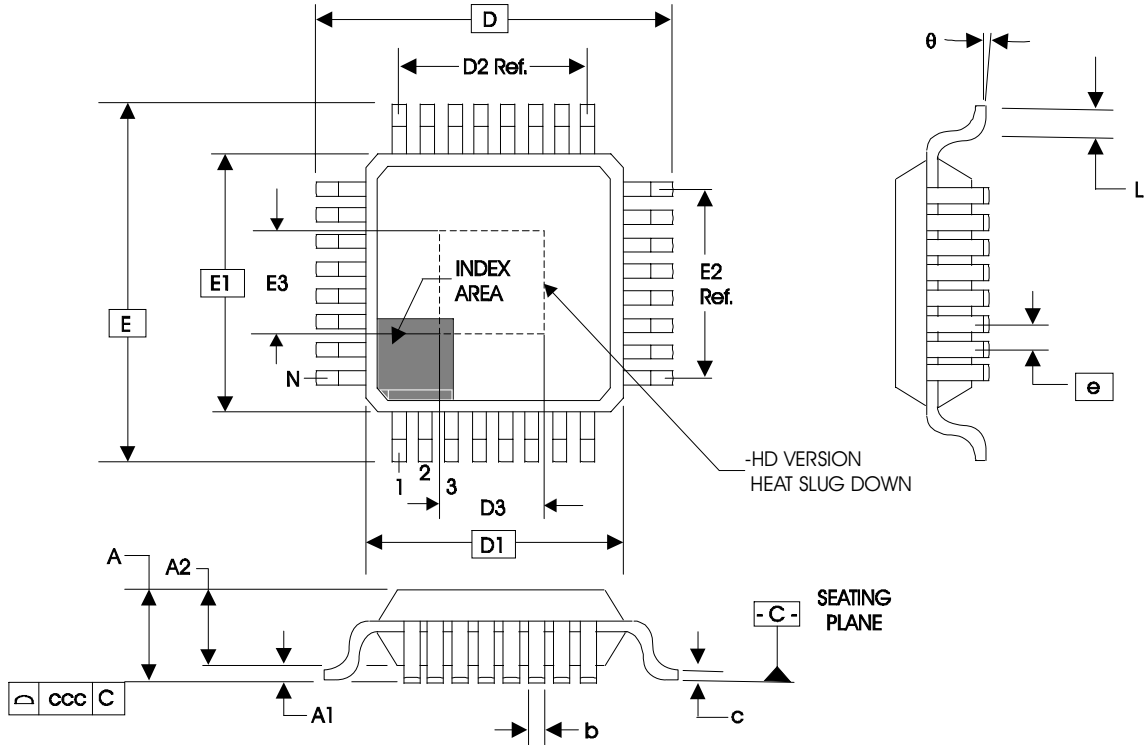

TABLE 8. PACKAGE DIMENSIONS

JEDEC VARIATION ALL DIMENSIONS IN MILLIMETERS			
SYMBOL	BBA		
	MINIMUM	NOMINAL	MAXIMUM
N	32		
A	--	--	1.20
A1	0.05	--	0.15
A2	0.95	1.0	1.05
b	0.30	0.35	0.40
c	0.09	--	0.20
D, E	9.00 BASIC		
D1, E1	7.00 BASIC		
D2, E2	5.60 Ref.		
D3, E3	3.0	3.5	4.0
e	0.80 BASIC		
L	0.45	0.60	0.75
theta	0°	--	7°
ccc	--	--	0.10

Reference Document: JEDEC Publication 95, MS-026

ICS853111B**LOW SKEW, 1-TO-10, DIFFERENTIAL-TO-2.5V, 3.3V LVPECL/ECL FANOUT BUFFER****TABLE 9. ORDERING INFORMATION**

Part/Order Number	Marking	Package	Shipping Packaging	Temperature
ICS853111BY	ICS853111BY	32 lead TQFP, E-PAD	tray	-40°C to 85°C
ICS853111BYT	ICS853111BY	32 lead TQFP, E-PAD	1000 tape & reel	-40°C to 85°C
ICS853111BYLF	ICS853111BYLF	"Lead Free" 32 lead TQFP, E-PAD	tray	-40°C to 85°C
ICS853111BYLFT	ICS853111BYLF	"Lead Free" 32 lead TQFP, E-PAD	1000 tape & reel	-40°C to 85°C

NOTE: Parts that are ordered with an "LF" suffix to the part number are the Pb-Free configuration and are RoHS compliant.

While the information presented herein has been checked for both accuracy and reliability, Integrated Device Technology, Incorporated (IDT) assumes no responsibility for either its use or for infringement of any patents or other rights of third parties, which would result from its use. No other circuits, patents, or licenses are implied. This product is intended for use in normal commercial and industrial applications. Any other applications such as those requiring high reliability or other extraordinary environmental requirements are not recommended without additional processing by IDT. IDT reserves the right to change any circuitry or specifications without notice. IDT does not authorize or warrant any IDT product for use in life support devices or critical medical instruments.

REVISION HISTORY SHEET				
Rev	Table	Page	Description of Change	Date
A		9	Corrected Figure 3C.	11/13/03
		17	Added "Lead Free" Part/Order Number rows.	
A		1	Features Section - added Lead-Free bullet.	6/16/05
	T8	16	Package Dimensions - corrected dimensions D2/E2 to read 3.5mm from 5.60.	
	T9	17	Ordering Information Table - corrected Lead-Free marking and added Lead-Free note.	
B	T4C	4	LVPECL DC Characteristics Table - corrected V_{IH} max. (@ 85°) 1.56V from -0.83V.	9/5/07
		10	Added <i>Recommendations for Unused Input and Output Pins</i> .	
	T8	16	Package Dimensions - added dimensions D3/E3.	

ICS853111B

LOW SKEW, 1-TO-10, DIFFERENTIAL-TO-2.5V, 3.3V LVPECL/ECL FANOUT BUFFER

Innovate with IDT and accelerate your future networks. Contact:

www.IDT.com

For Sales

800-345-7015
408-284-8200
Fax: 408-284-2775

For Tech Support

netcom@idt.com
480-763-2056

Corporate Headquarters

Integrated Device Technology, Inc.
6024 Silver Creek Valley Road
San Jose, CA 95138
United States
800 345 7015
+408 284 8200 (outside U.S.)

Asia Pacific and Japan

Integrated Device Technology
Singapore (1997) Pte. Ltd.
Reg. No. 199707558G
435 Orchard Road
#20-03 Wisma Atria
Singapore 238877
+65 6 887 5505

Europe

IDT Europe, Limited
321 Kingston Road
Leatherhead, Surrey
KT22 7TU
England
+44 (0) 1372 363 339
Fax: +44 (0) 1372 378851



www.IDT.com