



3825 Ohio Avenue, St. Charles, Illinois 60174
 1-800-SENSOR2, FAX: 630-377-6495
 www.systemsensor.com

ED-P, ED-PT, and ED-DP Intelligent Photoelectric Smoke Detectors

Specifications

Normal Operating Voltage:	15 to 30 VDC
Standby Current:	481µA max. @ 24 VDC (continuous broadcasts)
Alarm Current:	2 mA max. @ 24 VDC (LEDs on)
Humidity Range:	10% to 93% Relative Humidity, noncondensing
Temperature Range:	32°F to 120°F (0°C to 49°C); ED-P, ED-DP 32°F to 100°F (0°C to 38°C); ED-PT
Heat Detector:	135°F Fixed Temperature Electronic Thermistor
Height:	2.1 inches (51 mm) installed in EBF Base
Diameter:	6.1 inches (155 mm) installed in EBF Base 4.1 inches (104 mm) installed in EB Base
Weight:	5.2 oz. (147 g)

Before Installing

This detector must be installed in compliance with the control panel system installation manual. The installation must meet the requirements of the Authority Having Jurisdiction (AHJ). Detectors offer maximum performance when installed in compliance with the National Fire Protection Association (NFPA); see NFPA 72.

General Description

Models ED-P, ED-PT and ED-DP are intelligent photoelectric, spot-type smoke detectors utilizing sensing chambers that are designed to respond rapidly to a broad range of fires. The sensing chamber employs features that minimize the effects of settled dust on performance. Model ED-PT uses a thermistor based, 135°F heat detection circuit in addition to the photoelectric sensing chamber. ED-DP is designed for use inside the ED-DPR duct housing only. ED-DP should not be used in open area applications.

The detector is designed with tri-color LEDs to indicate detector status. The detector can be programmed to make the LEDs blink or be steady green, amber or red. The detector remote output can be configured to follow the LED or be independently controlled. A remote LED annunciator is available as an accessory (RA400Z).

The ED-P, ED-PT and ED-DP require compatible addressable communications to function properly. Connect these detectors to listed-compatible control panels only.

Spacing

System Sensor recommends spacing detectors in compliance with NFPA 72. In low air flow applications with smooth ceilings, the detectors should be spaced 30 feet

apart. For specific information regarding detector spacing, placement, and special applications, refer to NFPA 72 or the *System Smoke Detector Applications Guide*, available from System Sensor.

Duct Applications: ED-P and ED-PT are listed for use in ducts. See Duct Applications Guide A05-1004-XX for details on pendant mount applications.

Wiring Guide

All wiring must be installed in compliance with the National Electrical Code, applicable local codes, and any special requirements of the Authority Having Jurisdiction (AHJ). Proper wire gauges should be used. The installation wires should be color-coded to limit wiring mistakes and simplify system troubleshooting. Improper connections will prevent a system from responding properly in the event of a fire.

1. Wire the detector base (supplied separately) per the wiring diagram, see Figure 1.
2. Install the detector into the base. Push the detector into the base while turning it clockwise to secure it in place.
3. Set the desired address using the IR configuration tool (model no. EA-CT).
 Note: Maximum range for the EA-CT is 30 ft. (9 m).
4. Test the detector(s) as described in the TESTING section of this manual.

Figure 1. Wiring diagram:

CAUTION: Do not loop wire under terminal 1 or 3. Break wire run to provide supervision of connections.

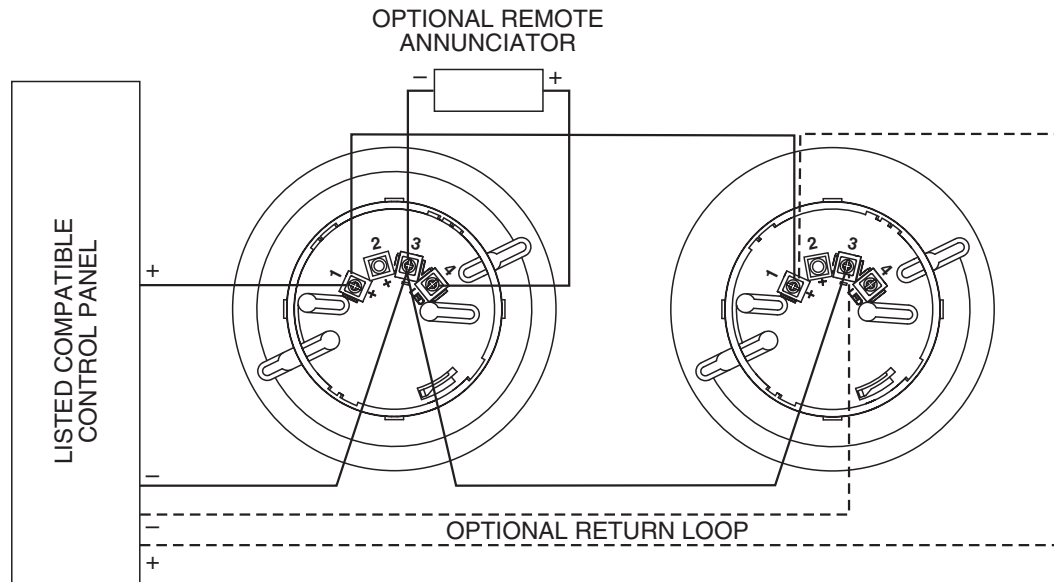

C0113-00

CAUTION

Dust covers provide limited protection against airborne dust particles during shipping. Dust covers must be removed before the detectors can sense smoke. Remove detectors prior to heavy remodeling or construction.

Tamper-Resistance

Models ED-P and ED-PT include a tamper-resistant capability that prevents their removal from the base without the use of a tool. Refer to the base manual for details on making use of this capability.

Testing

Before testing, notify the proper authorities that the system is undergoing maintenance, and will temporarily be out of service. Disable the system to prevent unwanted alarms.

All detectors must be tested after installation and periodically thereafter. Testing methods must satisfy the Authority Having Jurisdiction (AHJ). Detectors offer maximum performance when tested and maintained in compliance with NFPA 72.

The detector can be tested in the following ways:

A. Functional:

This detector can be functionally tested by using the EA-CT. Following the instructions, initiate the detector test sequence. The detector will then send a test alarm message to the panel. Refer to the control panel technical documentation for further information.

B. Smoke Entry:

Smoke entry testing should be performed immediately following the functional test. The functional test initiates an approximately 5 minute period when the detector's signal processing software routines are not active. Failure to do so will introduce a time delay before the detector alarms.

Home Safeguard Model 25S Smoke Detector Tester can be used to verify smoke entry into the sensing chamber and the corresponding alarm response. Aim the aerosol can at the detector and spray for one to two seconds from a distance of two to four feet until the panel alarms.

Another method is to use the GEMINI model 501 aerosol generator for smoke entry testing. Set the generator to represent 4%/ft. to 5%/ft. obscuration as described in the GEMINI 501 manual. Using the bowl shaped applicator, apply aerosol until the panel alarms.

C. Direct Heat (ED-PT only):

A hair dryer, heat gun, or test apparatus designed for this purpose should be used to test the thermistors. Direct the heat toward either of the two thermistors, using care to avoid damaging the plastic housing. The detector will reset only after it has had sufficient time to cool. Make sure that both thermistors are tested individually.

A detector that fails any of these tests should be cleaned as described under CLEANING, and retested. If the detector fails after cleaning, it must be replaced.

When testing is complete, restore the system to normal operation and notify the proper authorities that the system is back in operation.

Cleaning

Before removing the detector, notify the proper authorities that the smoke detector system is undergoing maintenance and will be temporarily out of service. Disable the zone or system undergoing maintenance to prevent unwanted alarms.

1. Remove the detector to be cleaned from the system.
2. Remove the detector cover by pressing firmly on each of the four removal tabs that hold the cover in place.
3. Vacuum the screen carefully without removing it. If further cleaning is required continue with Step 4, otherwise skip to Step 7.
4. Remove the chamber cover/screen assembly by pulling it straight out.
5. Use a vacuum cleaner or clean compressed air to remove dust and debris from the sensing chamber.
6. Reinstall the chamber cover/screen assembly by sliding the edge over the sensing chamber. Turn until it is firmly in place.
7. Replace the cover using the LEDs to align the cover and then gently pushing it until it locks into place. Make sure that the thermistors do not become bent under the cover on ED-PT models.
8. Reinstall the detector.
9. Test the detector as described in TESTING.
10. Reconnect disabled circuits.
11. Notify the proper authorities that the system is back on line.

Special Note Regarding Smoke Detector Guards

Smoke detectors are not to be used with detector guards unless the combination has been evaluated and found suitable for that purpose.

Figure 2. Detector assembly:

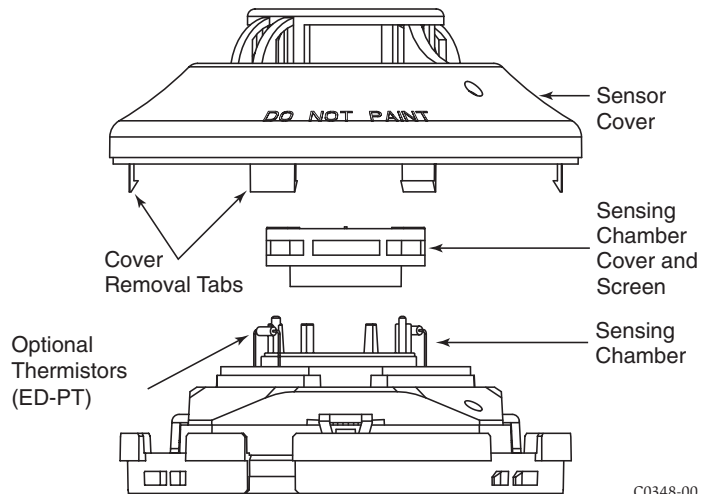

Please refer to insert for the Limitations of Fire Alarm Systems

Three-Year Limited Warranty

System Sensor warrants its enclosed smoke detector to be free from defects in materials and workmanship under normal use and service for a period of three years from date of manufacture. System Sensor makes no other express warranty for this smoke detector. No agent, representative, dealer, or employee of the Company has the authority to increase or alter the obligations or limitations of this Warranty. The Company's obligation of this Warranty shall be limited to the repair or replacement of any part of the smoke detector which is found to be defective in materials or workmanship under normal use and service during the three year period commencing with the date of manufacture. After phoning System Sensor's toll free number 800-SENSOR2 (736-7672) for a Return Authorization number, send defective units postage prepaid to: System Sensor, Returns

Department, RA # _____, 3825 Ohio Avenue, St. Charles, IL 60174. Please include a note describing the malfunction and suspected cause of failure. The Company shall not be obligated to repair or replace units which are found to be defective because of damage, unreasonable use, modifications, or alterations occurring after the date of manufacture. In no case shall the Company be liable for any consequential or incidental damages for breach of this or any other Warranty, expressed or implied whatsoever, even if the loss or damage is caused by the Company's negligence or fault. Some states do not allow the exclusion or limitation of incidental or consequential damages, so the above limitation or exclusion may not apply to you. This Warranty gives you specific legal rights, and you may also have other rights which vary from state to state.

FCC Statement

This device complies with part 15 of the FCC Rules. Operation is subject to the following two conditions: (1) This device may not cause harmful interference, and (2) this device must accept any interference received, including interference that may cause undesired operation.

Note: This equipment has been tested and found to comply with the limits for a Class B digital device, pursuant to Part 15 of the FCC Rules. These limits are designed to provide reasonable protection against harmful interference in a residential installation. This equipment generates, uses and can radiate radio frequency energy and, if not installed and used in accordance with the instructions, may cause harmful interference to radio communications. However, there is no guarantee that interference will not occur in a particular installation. If this equipment does cause harmful interference to radio or television reception, which can be determined by turning the equipment off and on, the user is encouraged to try to correct the interference by one or more of the following measures:

- Reorient or relocate the receiving antenna.
- Increase the separation between the equipment and receiver.
- Connect the equipment into an outlet on a circuit different from that to which the receiver is connected.
- Consult the dealer or an experienced radio/TV technician for help.