

1-Cell, 3-Pin, Step-Up DC/DC Converter

■ FEATURES

- A Guaranteed Start-Up from less than 0.9 V.
- High Efficiency.
- Low Quiescent Current.
- Less Number of External Components needed.
- Low Ripple and Low Noise.
- Fixed Output Voltage: 2.7V, 3.0V, 3.3V, 4.5V and 5V.
- Space Saving Packages: SOT-23, SOT-89 and TO-92.

■ APPLICATIONS

- Pagers.
- Cameras.
- Wireless Microphones.
- Pocket Organizers.
- Battery Backup Suppliers.
- Portable Instruments.

■ DESCRIPTION

The AIC1638 is a high efficiency step-up DC/DC converter for applications using 1 to 4 NiMH battery cells. Only three external components are required to deliver a fixed output voltage of 2.7V, 3.0V, 3.3V, 4.5V or 5V. The AIC1638 starts up from less than 0.9V input with 1mA load. Pulse Frequency Modulation scheme brings optimized performance for applications with light output loading and low input voltages. The output ripple and noise are lower compared with the circuits operating in PSM mode.

The PFM control circuit operating in 100KHz (max.) switching rate results in smaller passive components. The space saving SOT-23, SOT-89 and TO-92 packages make the AIC1638 an ideal choice of DC/DC converter for space conscious applications, like pagers, electronic cameras, and wireless microphones.

■ TYPICAL APPLICATION CIRCUIT

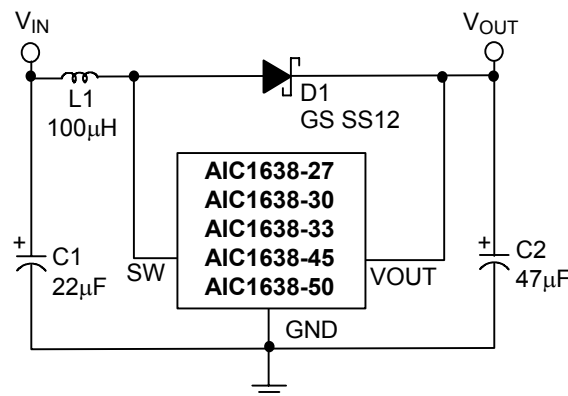

One Cell Step-Up DC/DC Converter

ORDERING INFORMATION

AIC1638-XX X X XX

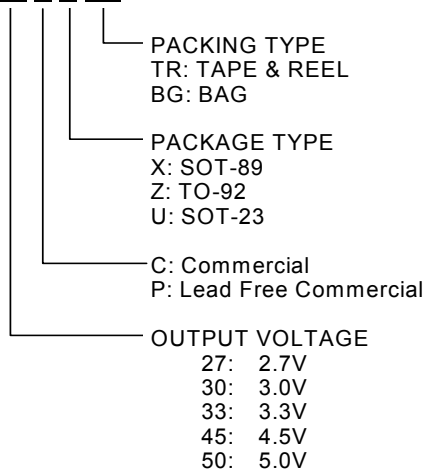

Example: AIC1638-27CXTR
 → 2.7V Version, in SOT-89 Package & Tape & Reel Packing Type
 AIC1638-27PXTR
 → 2.7V Version, in SOT-89 Lead Free Package & Tape & Reel Packing Type

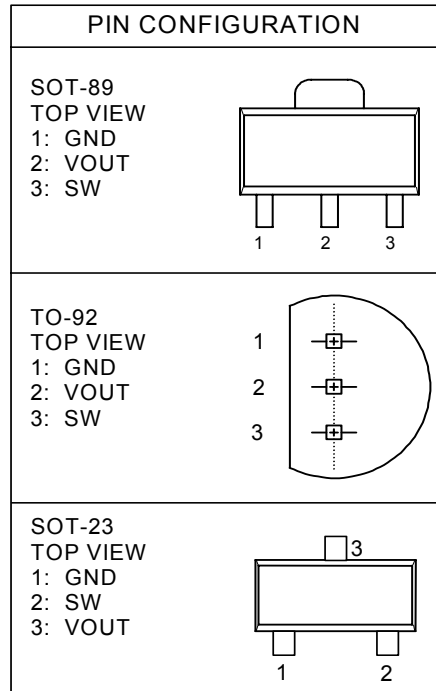

SOT-23 MARKING

Part No.	CU	PU
AIC1638-27	DA27	DA27P
AIC1638-30	DA30	DA30P
AIC1638-33	DA33	DA33P
AIC1638-45	DA45	DA45P
AIC1638-50	DA50	DA50P

SOT-89 MARKING

Part No.	CX	PX
AIC1638-27XX	AN27	AN27P
AIC1638-30XX	AN30	AN30P
AIC1638-33XX	AN33	AN33P
AIC1638-45XX	AN45	AN45P
AIC1638-50XX	AN50	AN50P

■ ABSOLUTE MAXIMUM RATINGS

Supply Voltage (VOUT pin).....	.6V
SW pin Voltage.....	.6V
SW pin Switch Current.....	0.6A
Operating Temperature Range.....	-40°C to 85°C
Maximum Junction Temperature.....	125°C
Storage Temperature Range.....	-65°C to 150 °C
Lead Temperature (Soldering 10 Sec.).....	260°C

Absolute Maximum Ratings are those values beyond which the life of a device may be impaired.

■ TEST CIRCUIT

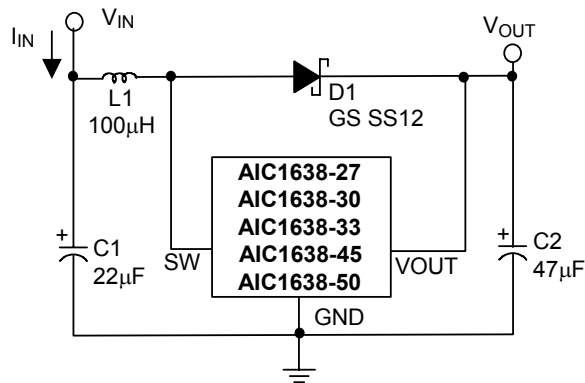

Fig. 1 Test Circuit 1

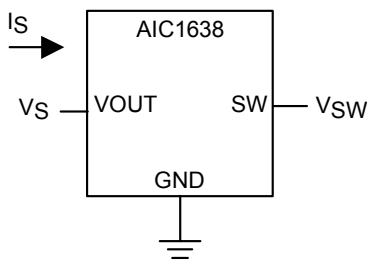

Fig. 2 Test Circuit 2

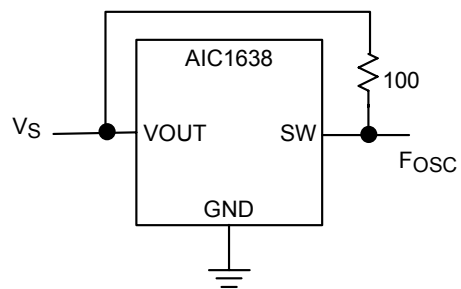

Fig. 3 Test Circuit 3

ELECTRICAL CHARACTERISTICS ($T_A=25^\circ\text{C}$, $I_{OUT}=10\text{mA}$, Unless otherwise specified) (Note1)

PARAMETER	TEST CONDITIONS	TEST CKT	SYMBOL	MIN.	TYP.	MAX.	UNIT
Output Voltage	AIC1638-27 $V_{IN}=1.8\text{V}$	1	V_{OUT}	2.633	2.700	2.767	V
	AIC1638-30 $V_{IN}=1.8\text{V}$			2.925	3.000	3.075	
	AIC1638-33 $V_{IN}=2.0\text{V}$			3.218	3.300	3.382	
	AIC1638-45 $V_{IN}=3.0\text{V}$			4.387	4.500	4.613	
	AIC1638-50 $V_{IN}=3.0\text{V}$			4.875	5.000	5.125	
Input Voltage	Normal Operation	1	V_{IN}			6	V
Start-Up Voltage	$I_{OUT}=1\text{mA}$, $V_{IN}:0 \rightarrow 2\text{V}$	1	V_{START}		0.8	0.9	V
Min. Hold-on Voltage	$I_{OUT}=1\text{mA}$, $V_{IN}:2 \rightarrow 0\text{V}$	1	V_{HOLD}			0.7	V
No-Load Input Current	$I_{OUT}=0\text{mA}$	1	I_{IN}		15		μA
Supply Current	AIC1638-27	2	I_{S1}		42		μA
	AIC1638-30			50			
	AIC1638-33			60			
	AIC1638-45			70			
	AIC1638-50			90			
$V_S=V_{OUT} \times 0.95$ Measurement of the IC input current (V_{OUT} pin)							
Supply Current	AIC1638-27	2	I_{S2}		7		μA
	AIC1638-30			7			
	AIC1638-33			7			
	AIC1638-45			7			
	AIC1638-50			7			
$V_S=V_{OUT} + 0.5\text{V}$ Measurement of the IC input current (V_{OUT} pin)							
SW Leakage Current	$V_{SW}=6\text{V}$, $V_S=V_{OUT} + 0.5\text{V}$	2				0.5	μA
SW Switch-On Resistance	AIC1638-27	2	R_{ON}		1.3		Ω
	AIC1638-30			1.2			
	AIC1638-33			1.1			
	AIC1638-45			1			
	AIC1638-50			1			
$V_S=V_{OUT} \times 0.95$, $V_{SW}=0.4\text{V}$							

ELECTRICAL CHARACTERISTICS (Continued)

PARAMETER	TEST CONDITIONS	TEST CKT	SYMBOL	MIN.	TYP.	MAX.	UNIT
Oscillator Duty Cycle	$V_S = V_{OUT} \times 0.95$ Measurement of the SW pin waveform	3	DUTY	65	75	85	%
Max. Oscillator Freq.	$V_S = V_{OUT} \times 0.95$ Measurement of the SW pin waveform	3	FOSC	80	105	130	KHz
Efficiency		1	η		85		%

Note 1: Specifications are production tested at $T_A = 25^\circ\text{C}$. Specifications over the -40°C to 85°C operating temperature range are assured by design, characterization and correlation with Statistical Quality Controls (SQC).

TYPICAL PERFORMANCE CHARACTERISTICS (Refer to Typical Application)

Capacitor (C2) : $47\mu\text{F}$ (Tantalum Type)

Diode (D1) : 1N5819 Schottky Type

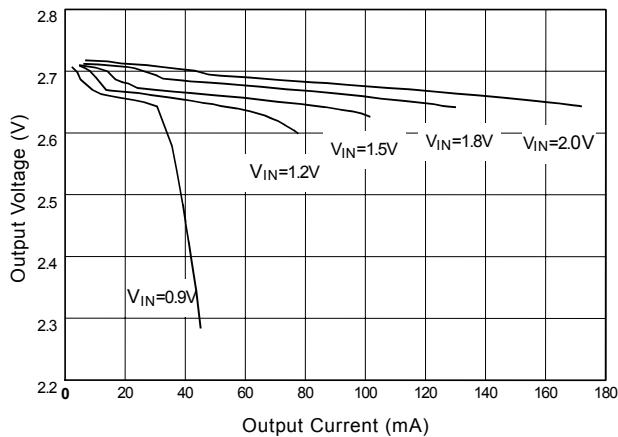

Fig. 4 AIC1638-27 Load Regulation (L=100 μH CD54)

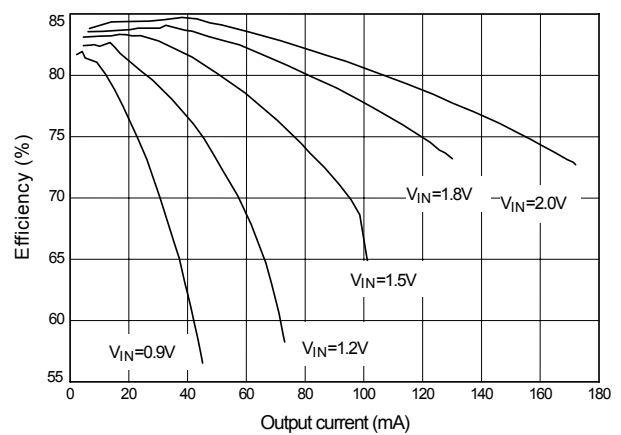

Fig. 5 AIC1638-27 Efficiency (L=100 μH CD54)

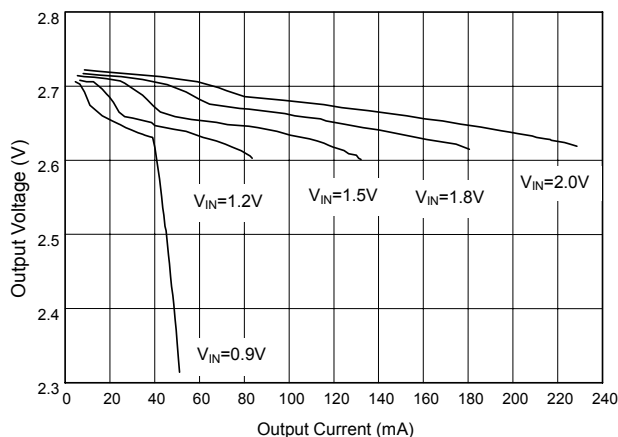

Fig. 6 AIC1638-27 Load Regulation (L=47 μH CD54)

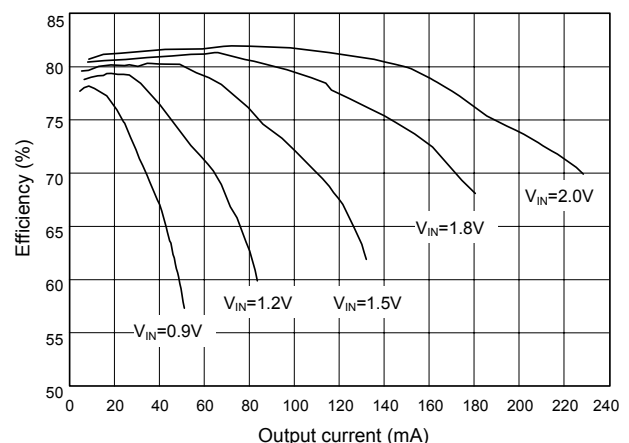

Fig. 7 AIC1638-27 Efficiency (L=47 μH CD54)

TYPICAL PERFORMANCE CHARACTERISTICS (Continued)

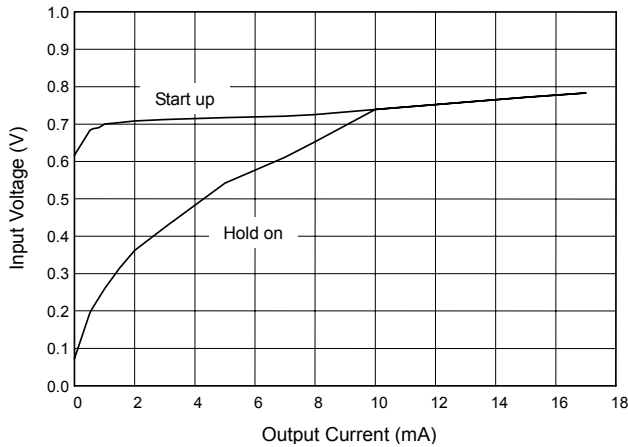

Fig. 8 AIC1638-27 Start-Up & Hold-ON Voltage (L=47µH CD54)

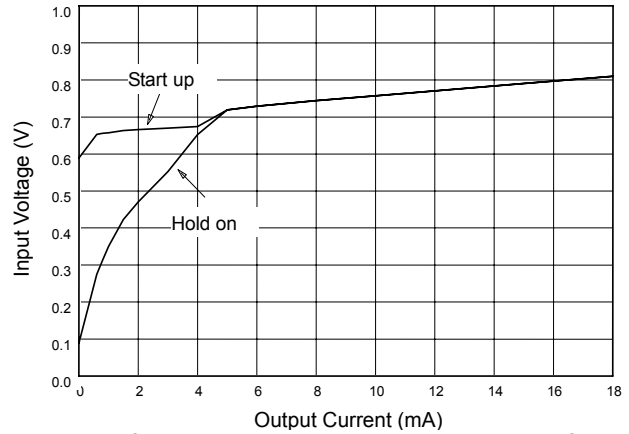

Fig. 9 AIC1638-27 Start-Up & Hold-ON Voltage (L=100µH CD54)

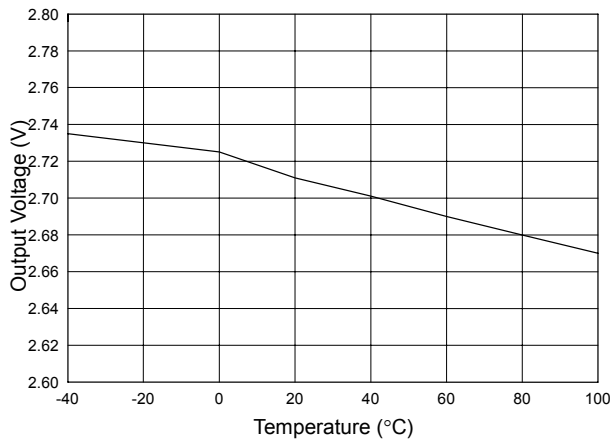

Fig. 10 AIC1638-27 Output Voltage vs. Temperature

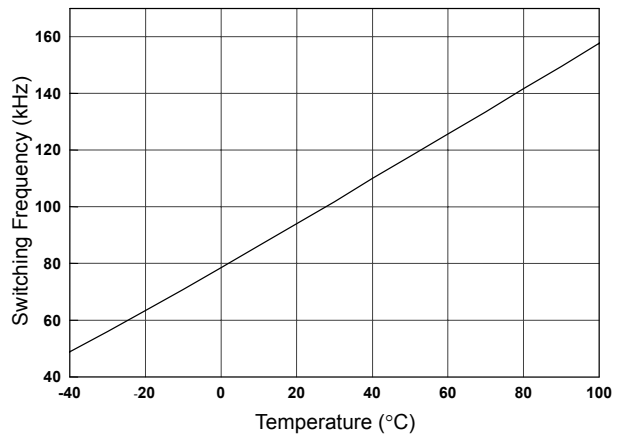

Fig. 11 AIC1638-27 Switching Frequency vs. Temperature

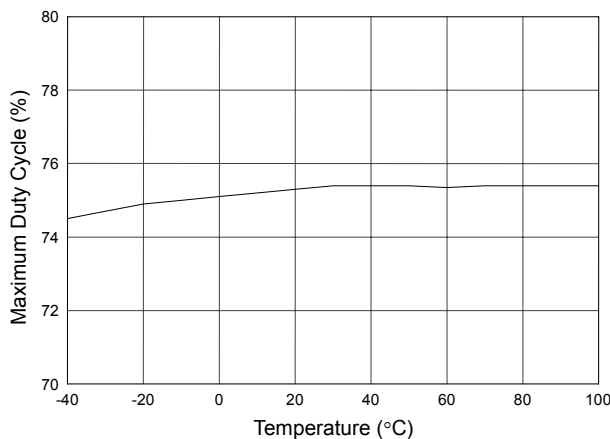

Fig. 12 AIC1638-27 Maximum Duty Cycle vs. Temperature

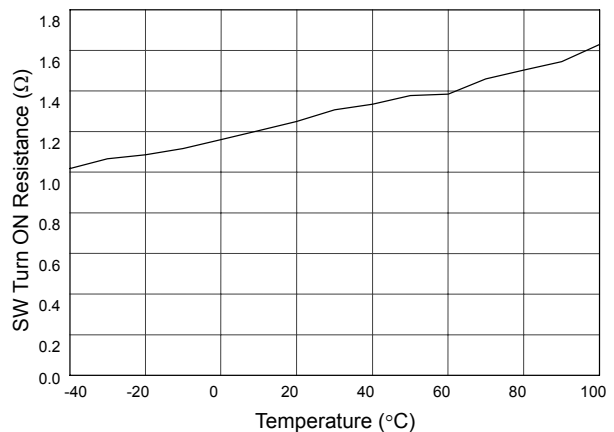

Fig. 13 AIC1638-27 SW Turn ON Resistance vs. Temperature

■ TYPICAL PERFORMANCE CHARACTERISTICS (Continued)

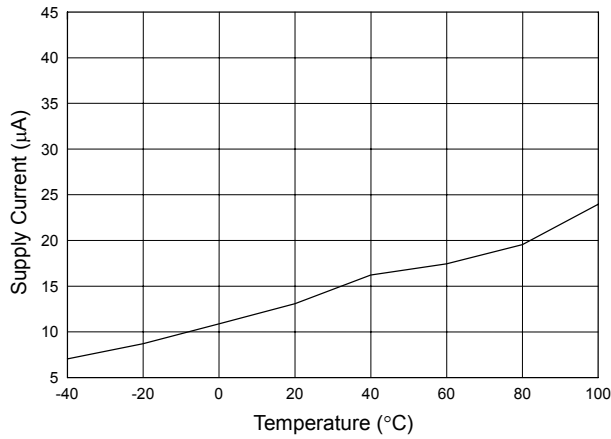

Fig. 14 AIC1638-27 Supply Current vs. Temperature

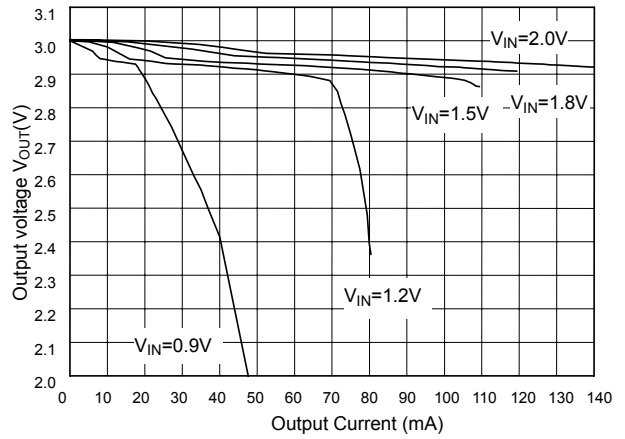

Fig. 15 AIC1638-30 Load Regulation (L=100µH, CD54)

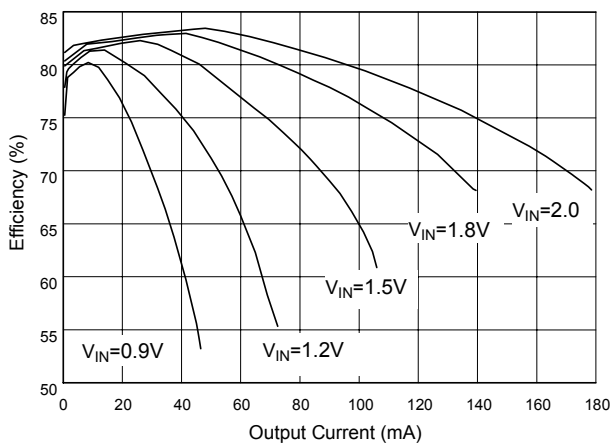

Fig. 16 AIC1638-30 Efficiency (L=100µH, CD54)

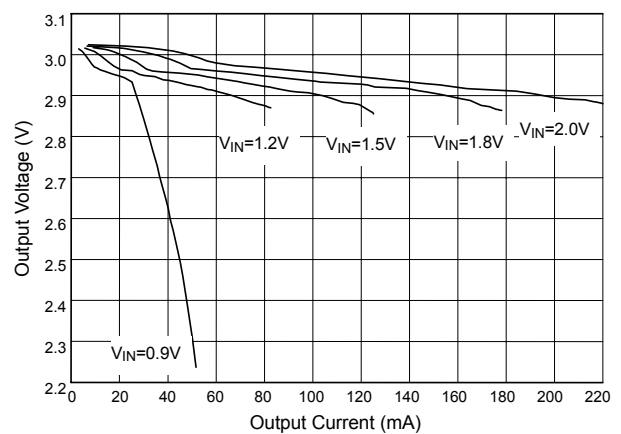

Fig. 17 AIC1638-30 Load Regulation (L=47µH, CD54)

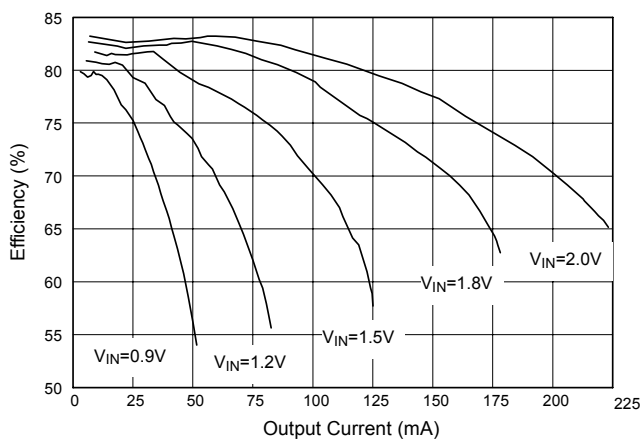

Fig. 18 AIC1638-30 Efficiency (L=47µH, CD54)

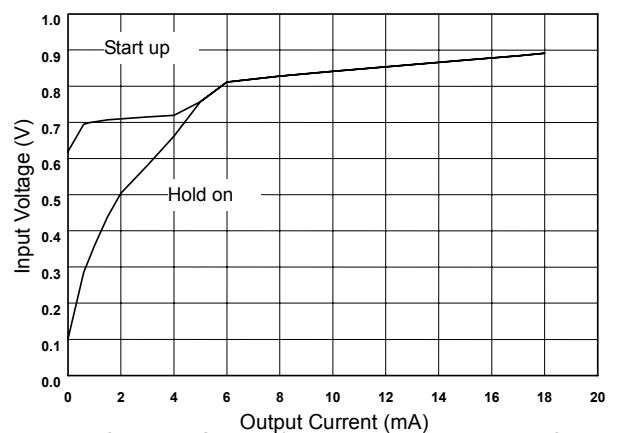

Fig. 19 AIC1638-30 Start-up & Hold-on Voltage (L=100µH, CD54)

■ TYPICAL PERFORMANCE CHARACTERISTICS (Continued)

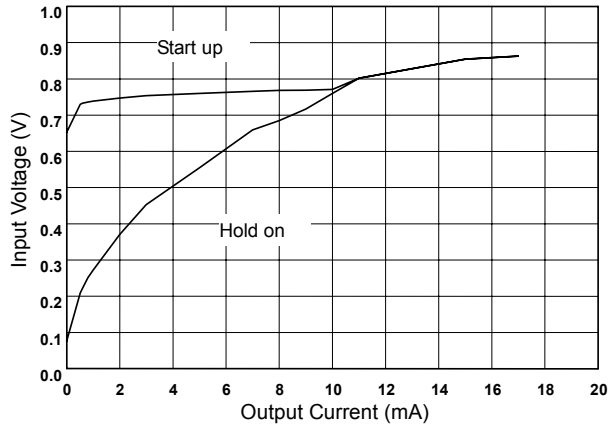

Fig. 20 AIC1638-30 Start-up & Hold-on Voltage (L=47 μ H CD54)

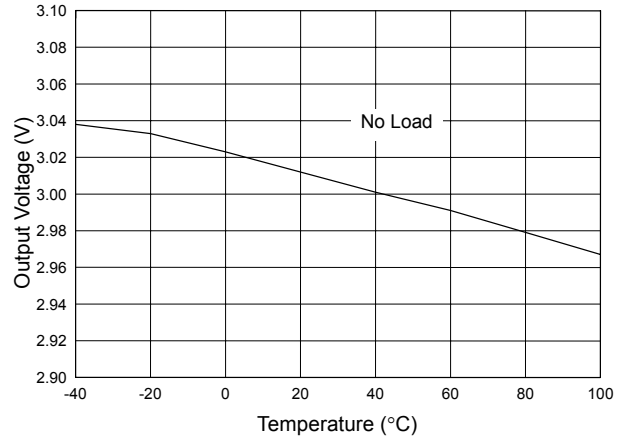

Fig. 21 AIC1638-30 Output Voltage vs. Temperature

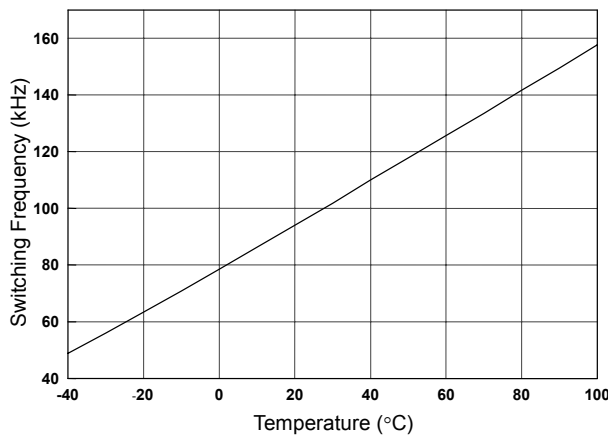

Fig. 22 AIC1638-30 Switching Frequency vs. Temperature

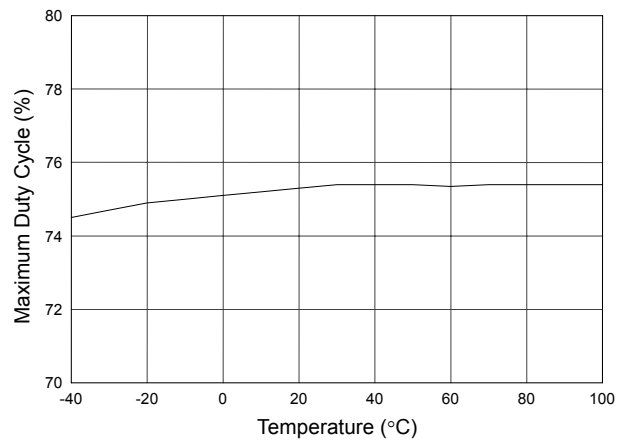

Fig. 23 AIC1638-30 Maximum Duty Cycle vs. Temperature

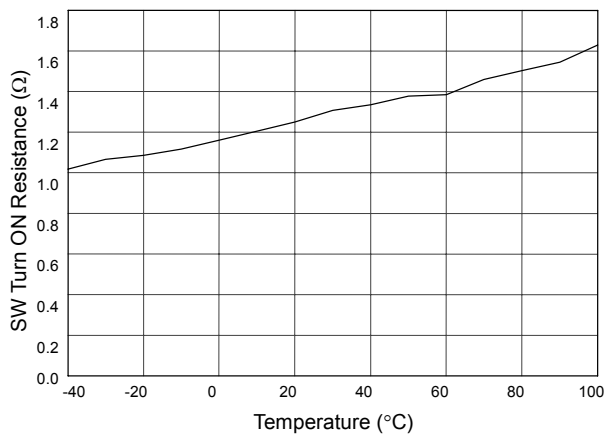

Fig. 24 AIC1638-30 SW Turn ON Resistance vs. Temperature

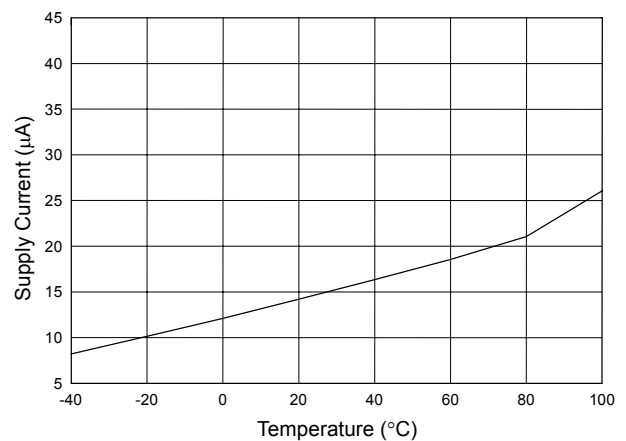

Fig. 25 AIC1638-30 Supply Current vs. Temperature

■ TYPICAL PERFORMANCE CHARACTERISTICS (Continued)

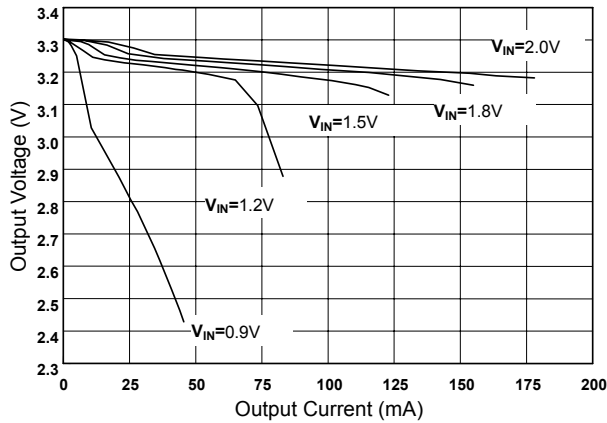

Fig. 26 AIC1638-33 Load Regulation (L=100µH, CD54)

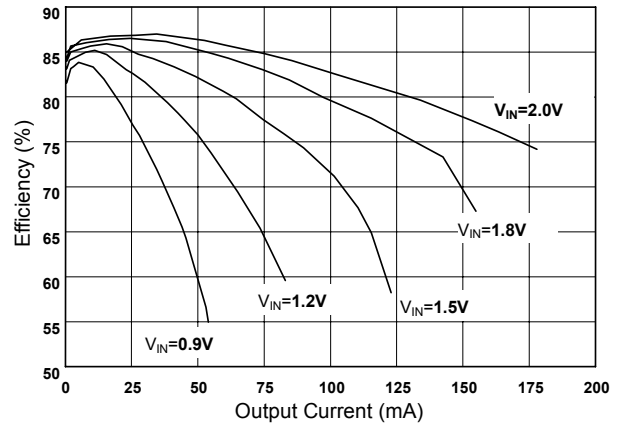

Fig. 27 AIC1638-33 Efficiency (L=100µH, CD54)

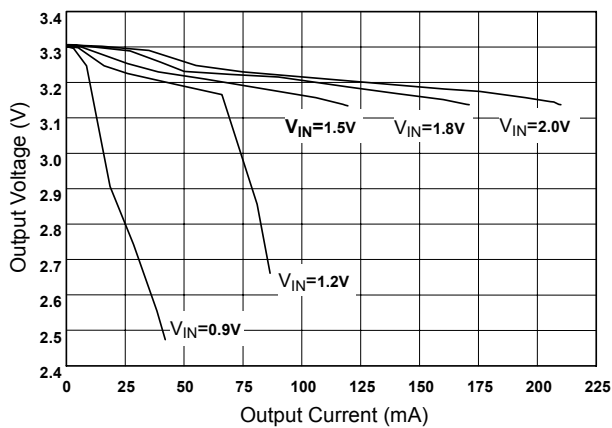

Fig. 28 AIC1638-33 Load Regulation (L=47µH, CD54)

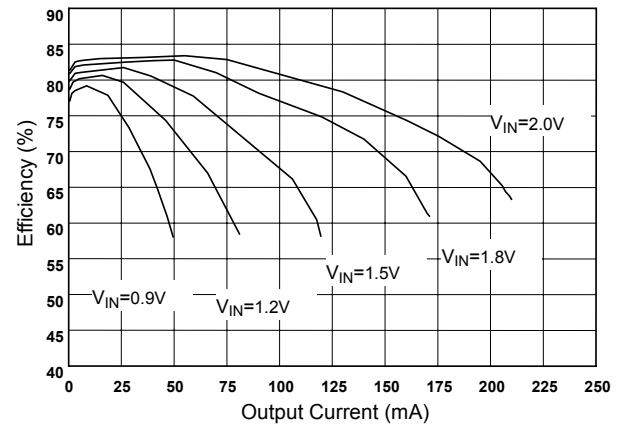

Fig. 29 AIC1638-33 Efficiency (L=47µH, CD54)

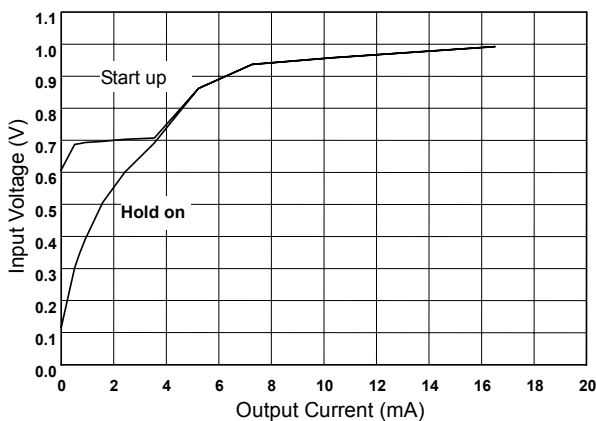

Fig. 30 AIC1638-33 Start-up & Hold-on Voltage (L=100µH CD54)

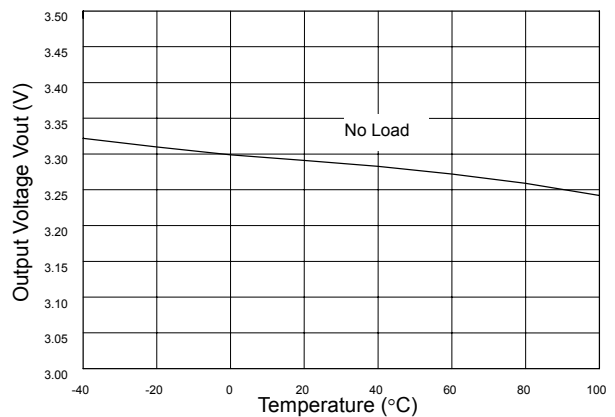

Fig. 31 AIC1638-33 Output Voltage vs. Temperature

■ TYPICAL PERFORMANCE CHARACTERISTICS (Continued)

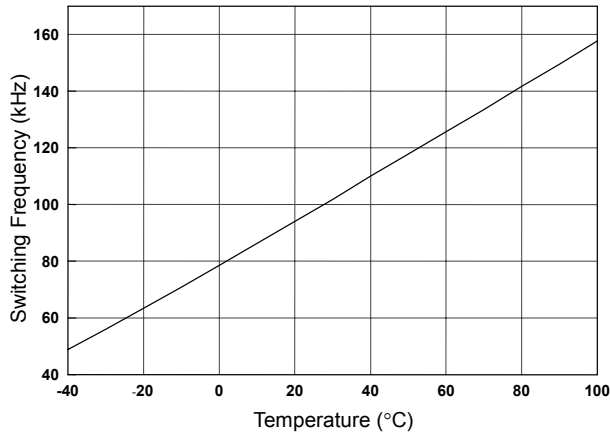

Fig. 32 AIC1638-33 Switching Frequency vs. Temperature

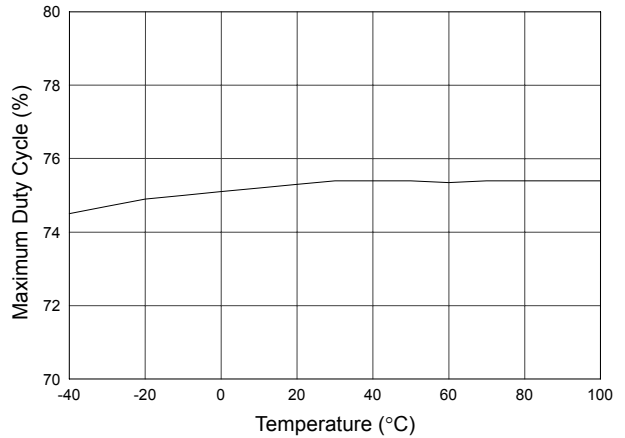

Fig. 33 AIC1638-33 Maximum Duty Cycle vs. Temperature

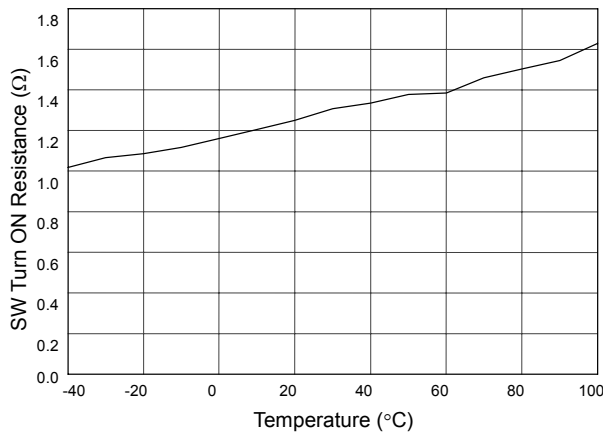

Fig. 34 AIC1638-33 SW Turn ON Resistance vs. Temperature

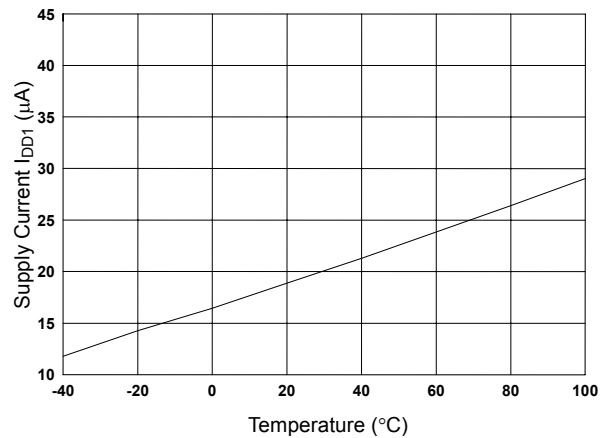

Fig. 35 AIC1638-33 Supply Current vs. Temperature

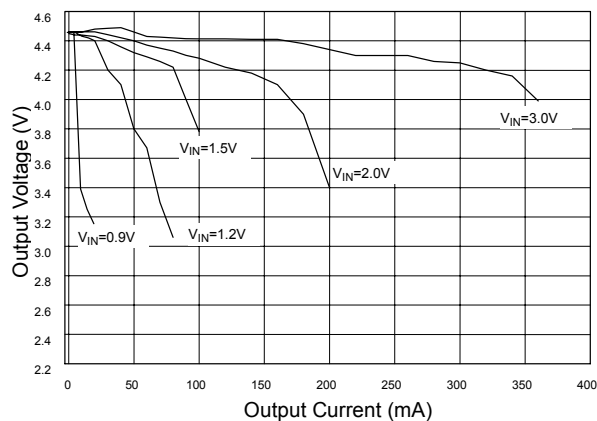

Fig. 36 AIC1638-45 Load Regulation (L=100μH)

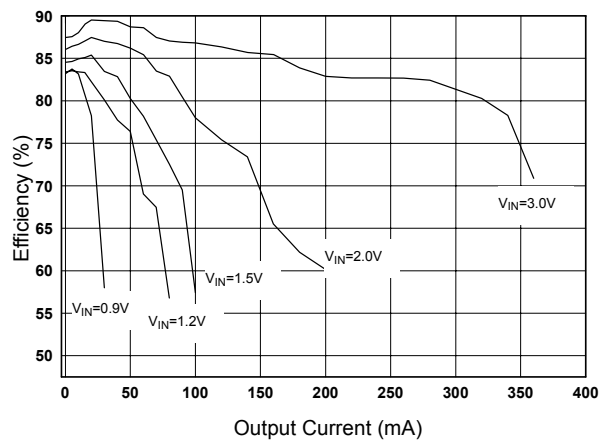

Fig. 37 AIC1638-45 Efficiency (L=100μH)

■ TYPICAL PERFORMANCE CHARACTERISTICS (Continued)

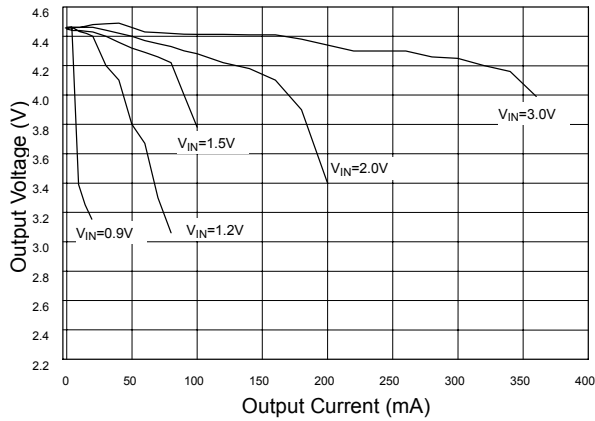

Fig. 38 AIC1638-45 Load Regulation (L=100µH)

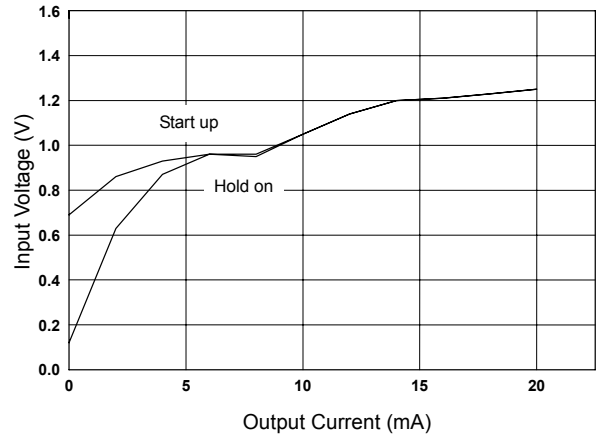

Fig. 39 AIC1638-45 Start-up & Hold-On Voltage (L=100µH)

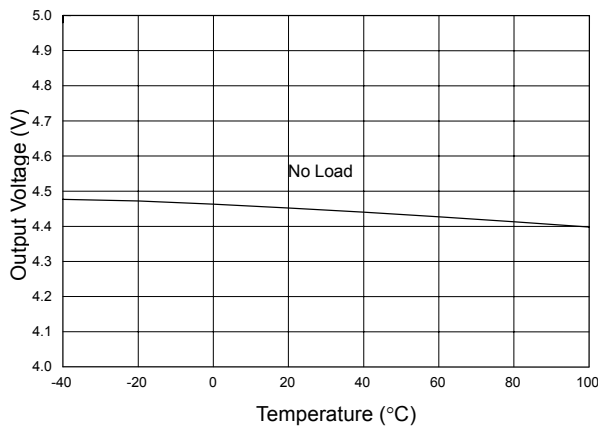

Fig. 40 AIC1638-45 Output Voltage vs. Temperature

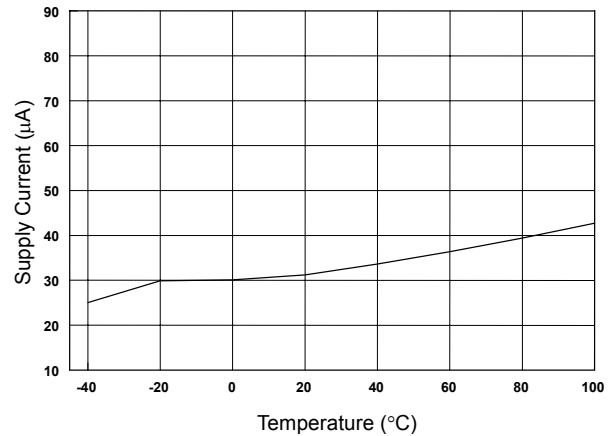

Fig. 41 AIC1638-45 Supply Current vs. Temperature

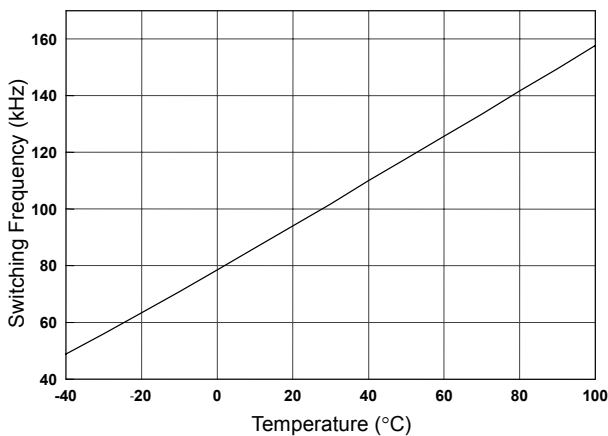

Fig. 42 AIC1638-45 Switching Frequency vs. Temperature

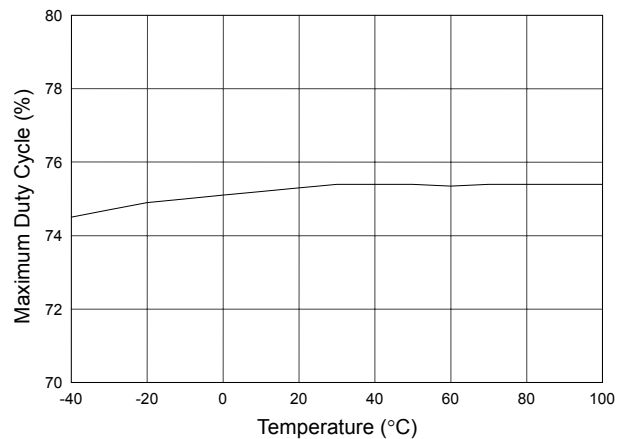

Fig. 43 AIC1638-45 Maximum Duty Cycle vs. Temperature

■ TYPICAL PERFORMANCE CHARACTERISTICS (Continued)

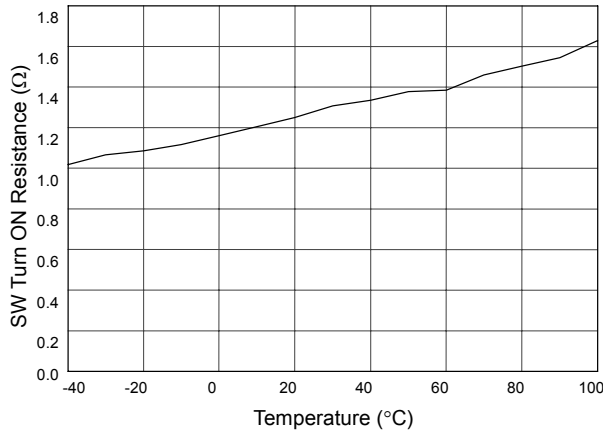

Fig. 44 AIC1638-45 SW Turn ON Resistance vs. Temperature

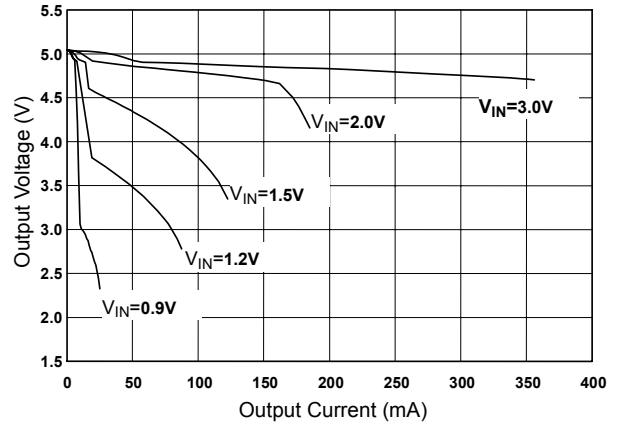

Fig. 45 AIC1638-50 Load Regulation (L=100μH CD54)

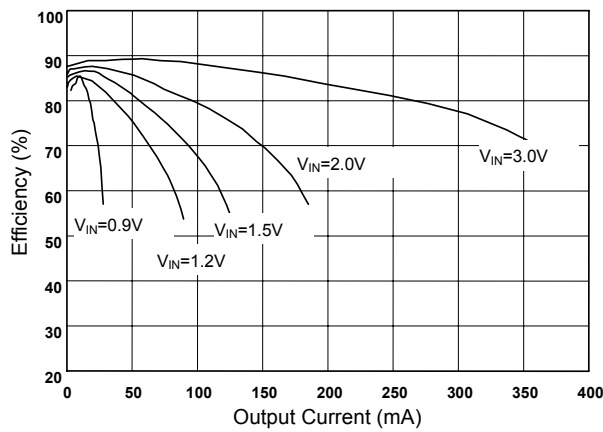

Fig. 46 AIC1638-50 Efficiency (L=100μH CD54)

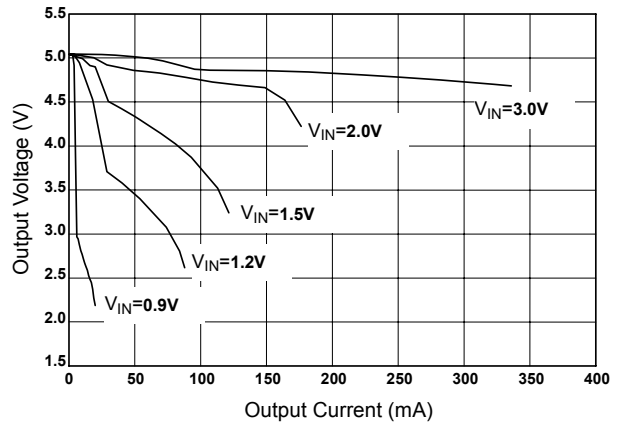

Fig. 47 AIC1638-50 Load Regulation (L=47μH CD54)

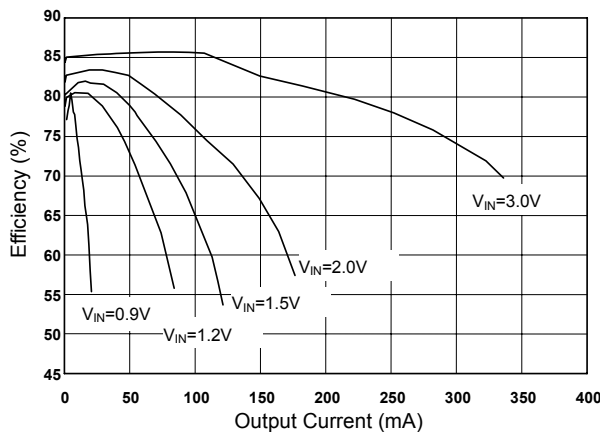

Fig. 48 AIC1638-50 Efficiency (L=47μH CD54)

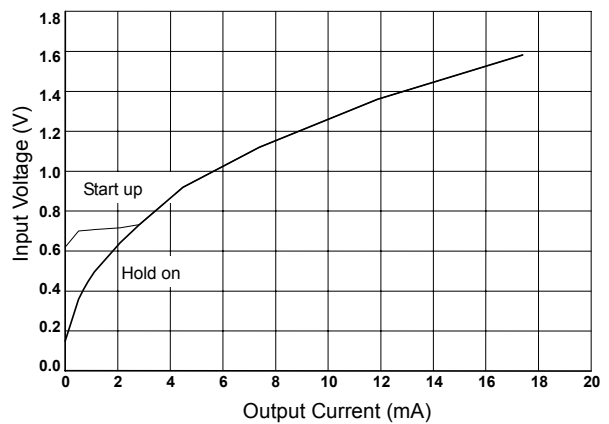

Fig. 49 AIC1638-50 Start-up & Hold-on Voltage (L=100μH CD50)

■ TYPICAL PERFORMANCE CHARACTERISTICS (Continued)

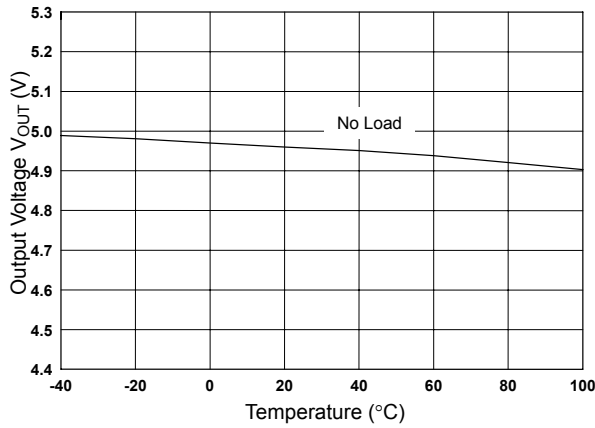

Fig. 50 AIC1638-50 Output Voltage vs. Temperature

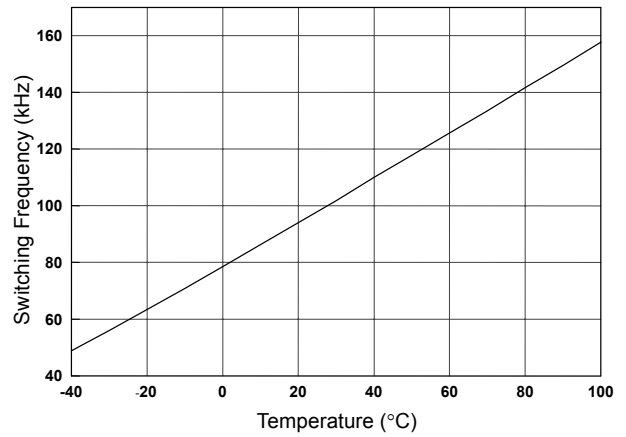

Fig. 51 AIC1638-50 Switching Frequency vs. Temperature

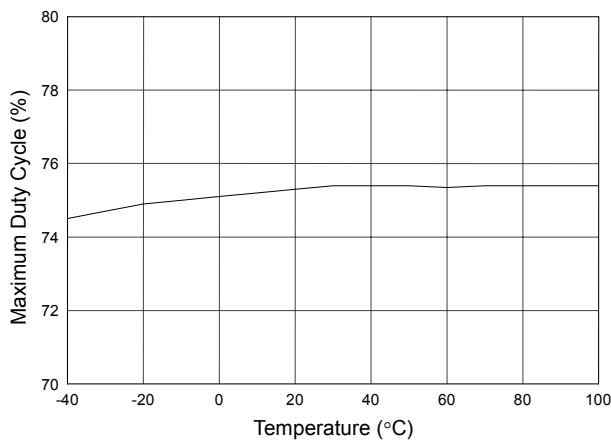

Fig. 52 AIC1638-50 Maximum Duty Cycle vs. Temperature

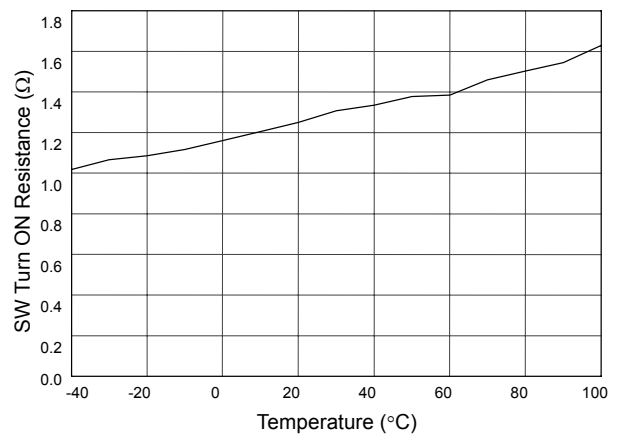

Fig. 53 AIC1638-50 SW Turn ON Resistance vs. Temperature

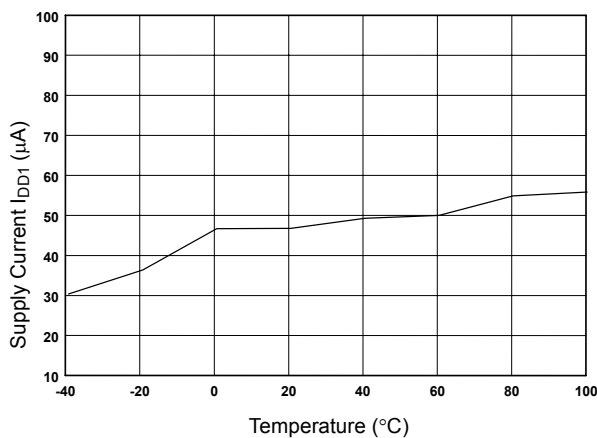

Fig. 54 AIC1638-50 Supply Current vs. Temperature

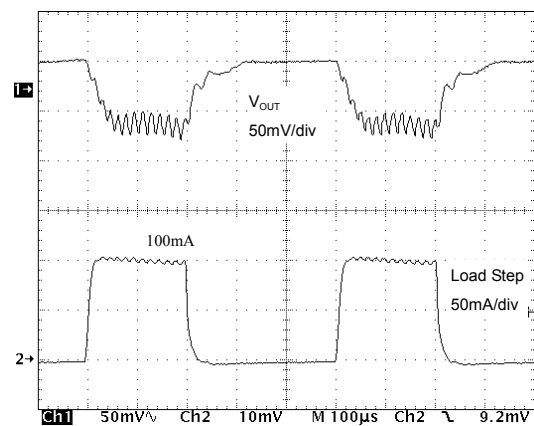

Fig. 55 Load Transient Response
($L_1=100\mu\text{H}$, $C_2=47\mu\text{F}$, $V_{IN}=2\text{V}$)

TYPICAL PERFORMANCE CHARACTERISTICS (Continued)

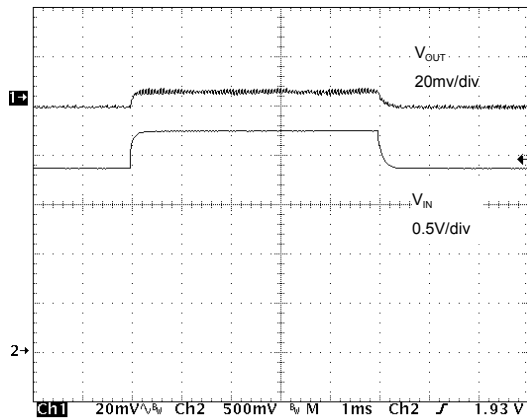
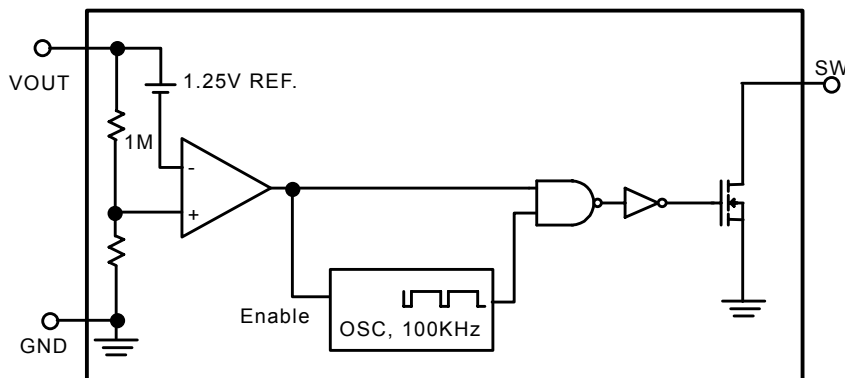

Fig. 56 Line Transient Response
($L_1=100\mu\text{H}$, $C_2=47\mu\text{F}$)

BLOCK DIAGRAM



PIN DESCRIPTIONS

PIN 1 : GND - Ground. Must be low impedance; solder directly to ground plane.

PIN 3 : SW - Internal drain of N-MOSFET switch.

PIN 2 : VOUT - IC supply pin. Connect VOUT to the converter output.

APPLICATION INFORMATION

GENERAL DESCRIPTION

AIC1638 PFM (pulse frequency modulation) converter ICs combines a switch mode converter, N-channel power MOSFET, precision voltage reference, and voltage detector in a single monolithic device. They offer both extreme low quiescent current, high efficiency, and very low gate threshold voltage to ensure start-up with low battery voltage (0.8V typ.). Designed to maximize battery life in portable products, and minimize switching losses by only switching as needed service the load.

PFM converters transfer a discrete amount of energy per cycle and regulate the output voltage by modulating switching frequency with the constant turn-on time. Switching frequency depends on load, input voltage, and inductor value, and it can range up to 100KHz. The SW on-resistance is typically 1 to 1.5Ω to minimize switch losses.

When the output voltage drops, the error comparator enables 100KHz oscillator that turns on the MOSFET around 7.5μS and 2.5μS off time. Turning on the MOSFET allows inductor current to ramp up, storing energy in a magnetic field. When MOSFET turns off that force inductor current through diode to the output capacitor and load. As the stored energy is depleted, the current ramp down until the diode turns off. At this point, inductor may ring due to residual energy and stray capacitance. The output capacitor stores charge when current flowing through the diode is high, and release it when current is low, thereby maintaining a steady voltage across the load.

As the load increases, the output capacitor discharges faster and the error comparator initiates cycles sooner, increasing the switching frequency. The maximum duty cycle ensure adequate time for energy transfer to output during the second half

each cycle. Depending on circuit, PFM converter can operate in either discontinuous mode or continuous conduction mode. Continuous conduction mode means that the inductor current does not ramp to zero during each cycle.

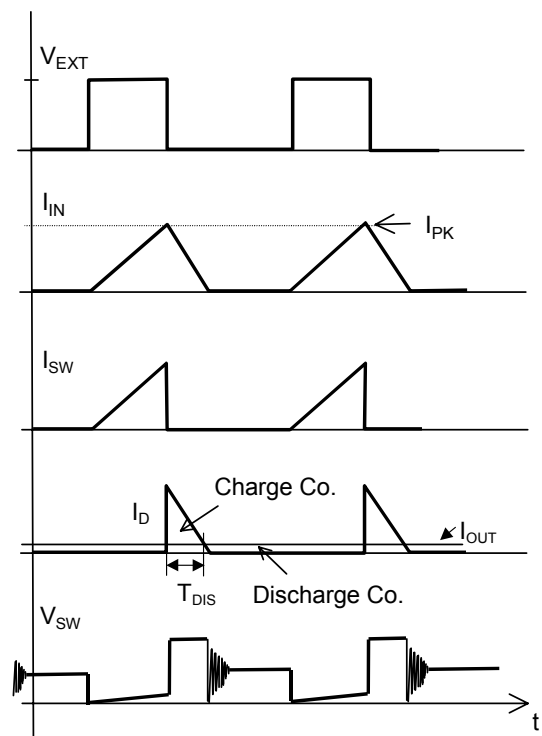
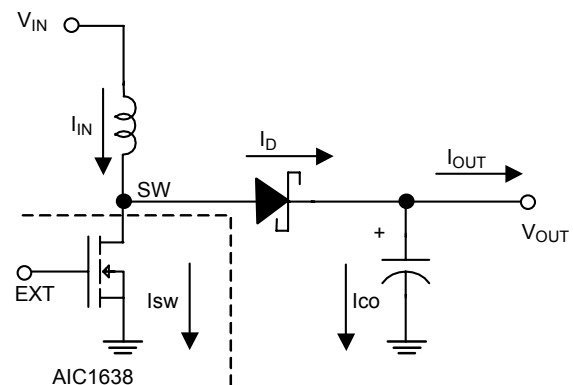

Discontinuous Conduction Mode

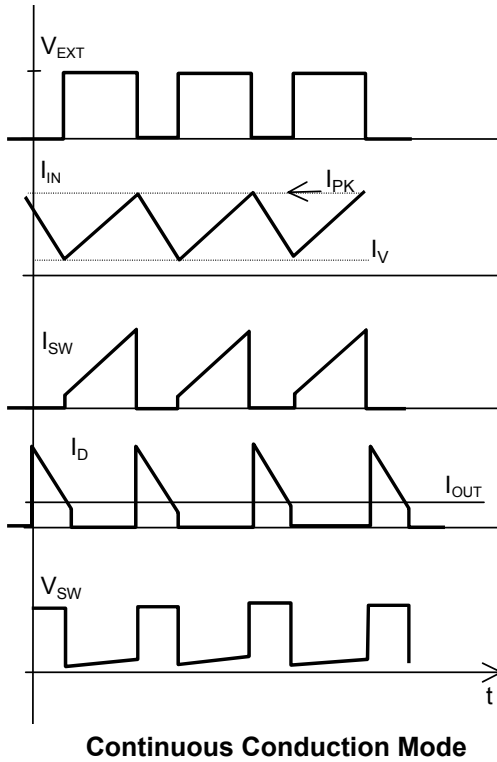

At the boundary between continuous and discontinuous mode, output current (I_{OB}) is determined by

$$I_{OB} = \left(\frac{V_{IN}}{V_{OUT} + V_D} \right) \frac{1}{2} \frac{V_{IN}}{L} T_{ON}(1-x)$$

where V_D is the diode drop,

$$x = (R_{ON} + R_S) T_{ON} / L.$$

R_{ON} = Switch turn on resistance, R_S = Inductor DC resistance

T_{ON} = Switch ON time

In the discontinuous mode, the switching frequency (F_{sw}) is

$$F_{sw} = \frac{2(L)(V_{OUT} + V_D - V_{IN})(I_{OUT})}{V_{IN}^2 \times T_{ON}^2} (1+x)$$

In the continuous mode, the switching frequency is

$$f_{sw} = \frac{1}{T_{ON}} \frac{(V_{OUT} + V_D - V_{IN})}{(V_{OUT} + V_D - V_{SW})} \times \left[1 + \frac{x}{2} \left(\frac{V_{IN} - V_{SW}}{V_{OUT} + V_D - V_{SW}} \right) \right]$$

$$\cong \frac{1}{T_{ON}} \left(\frac{V_{OUT} + V_D - V_{IN}}{V_{OUT} + V_D - V_{SW}} \right)$$

where V_{sw} = switch drop and proportion to output current.

INDUCTOR SELECTION

To operate as an efficient energy transfer element, the inductor must fulfill three requirements. First, the inductance must be low enough for the inductor to store adequate energy under the worst-case condition of minimum input voltage and switch ON time. Second, the inductance must also be high enough so maximum current rating of AIC1638 and inductor are not exceeded at the other worst-case condition of maximum input voltage and ON time. Lastly, the inductor must have sufficiently low DC resistance so excessive power is not lost as heat in the windings. But unfortunately this is inversely related to physical size.

Minimum and Maximum input voltage, output voltage and output current must be established before and inductor can be selected.

In discontinuous mode operation, at the end of the switch ON time, peak current and energy in the inductor build according to

$$I_{PK} = \left(\frac{V_{in}}{R_{on} + R_s} \right) \left(1 - \exp\left(-\frac{R_{on} + R_s}{L} T_{on}\right) \right)$$

$$\cong \left(\frac{V_{IN}}{L} \right) (T_{ON}) \left(1 - \frac{x}{2} \right)$$

$$\cong \frac{V_{IN}}{L} T_{ON} \quad (\text{Simple losses equation}),$$

where $x = (R_{ON} + R_S) T_{ON} / L$

$$EL = \frac{1}{2}L \times I_{PK}^2$$

Power required from the inductor per cycle must be equal or greater than

$$PL/F_{SW} = (V_{OUT} + V_D - V_{IN})(I_{OUT})\left(\frac{1}{F_{SW}}\right)$$

in order for the converter to regulate the output.

When loading is over I_{OB} , PFM converter operates in continuous mode. Inductor peak current can be derived from

$$I_{PK} = \left(\frac{V_{OUT} + V_D - V_{SW}}{V_{IN} - V_{SW}} - \frac{x}{2}\right)I_{OUT} + \left(\frac{V_{IN} - V_{SW}}{2L}\right)T_{ON}\left(1 - \frac{x}{2}\right)$$

Valley current (I_V) is

$$I_V = \left(\frac{V_{OUT} + V_D - V_{SW}}{V_{IN} - V_{SW}} - \frac{x}{2}\right)I_{OUT} - \left(\frac{V_{IN} - V_{SW}}{2L}\right) \times T_{ON}\left(1 - \frac{x}{2}\right)$$

Table 1 Indicates resistance and height for each coil.

Power Inductor Type		Inductance (μH)	Resistance (Ω)	Rated Current (A)	Height (mm)
Coilcraft SMT Type (www.coilcraft.com)	DS1608	22	0.10	0.7	2.9
		47	0.18	0.5	
		100	0.38	0.3	
	DO3316	22	0.08	2.7	5.2
		47	0.14	1.8	
Sumida SMT Type CD54		47	0.25	0.7	4.5
		100	0.50	0.5	
Hold SMT Type PM54		47	0.25	0.7	4.5
		100	0.50	0.5	
Hold SMT Type PM75		33	0.11	1.2	5.0

CAPACITOR SELECTION

A poor choice for a output capacitor can result in poor efficiency and high output ripple. Ordinary aluminum electrolyzers, while inexpensive may have unacceptably poor ESR and ESL. There are low ESR aluminum capacitors for switch mode DC-DC converters which work much better than general propose unit. Tantalum capacitors provide still better performance at more expensive. OS-CON capacitors have extremely low ESR in a small size. If capacitance is reduced, output ripple will increase.

Most of the input supply is supplied by the input bypass capacitor, the capacitor voltage rating

should be at least 1.25 times greater than a maximum input voltage.

DIODE SELECTION

Speed, forward drop, and leakage current are the three main considerations in selecting a rectifier diode. Best performance is obtained with Schottky rectifier diode, such as 1N5819. Motorola makes MBR0530 in surface mount. For lower output power a 1N4148 can be used although efficiency and start-up voltage will suffer substantially.

COMPONENT POWER DISSIPATION

Operating in discontinuous mode, power loss in the winding resistance of inductor can be approximate equal to

$$PD_L = \frac{2}{3} \left(\frac{T_{ON}}{L} \right) (R_s) \left(\frac{V_{OUT} + V_D}{V_{OUT}} \right) (P_{OUT})$$

where $P_{OUT} = V_{OUT} \times I_{OUT}$; $R_s =$ Inductor DC R;

$V_D =$ Diode drop.

The power dissipated in a switch loss is

$$PD_{sw} = \frac{2}{3} \left(\frac{T_{ON}}{L} \right) (R_{ON}) \left(\frac{V_{OUT} + V_D - V_{IN}}{V_{OUT}} \right) (P_{OUT})$$

The power dissipated in rectifier diode is

$$PD_D = \left(\frac{V_D}{V_{OUT}} \right) (P_{OUT})$$

PHYSICAL DIMENSION (unit: mm)

● SOT-23

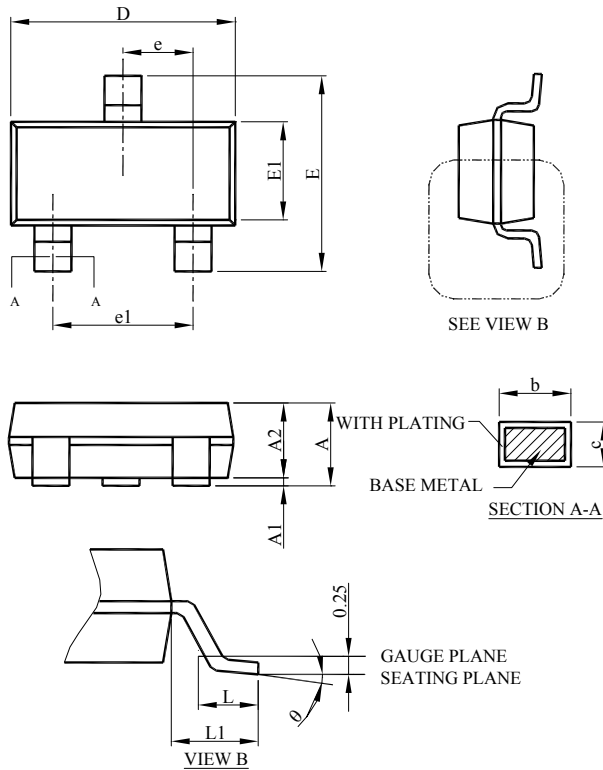

SYMBOL	SOT-23	
	MILLIMETERS	
	MIN.	MAX.
A	0.95	1.45
A1	0.05	0.15
A2	0.90	1.30
b	0.30	0.50
c	0.08	0.22
D	2.80	3.00
E	2.60	3.00
E1	1.50	1.70
e	0.95 BSC	
e1	1.90 BSC	
L	0.30	0.60
L1	0.60 REF	
θ	0°	8°

● SOT-89

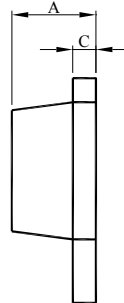
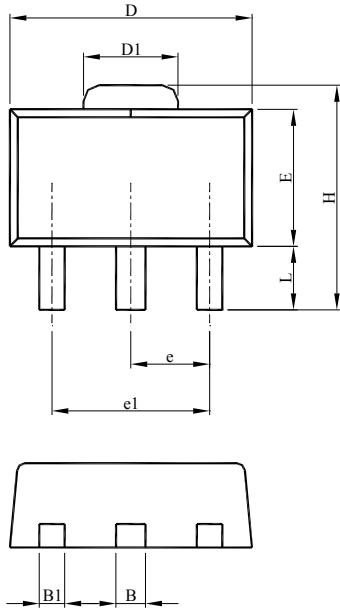

SOT-89		
MILLIMETERS		
SYMBOL	MIN.	MAX.
A	1.40	1.60
B	0.44	0.56
B1	0.36	0.48
C	0.35	0.44
D	4.40	4.60
D1	1.50	1.83
E	2.29	2.60
e	1.50 BSC	
e1	3.00 BSC	
H	3.94	4.25
L	0.89	1.20

● TO-92

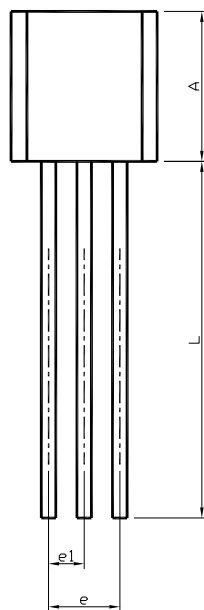
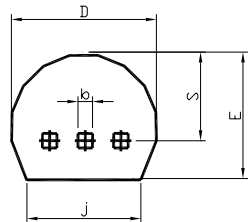

TO-92		
MILLIMETERS		
SYMBOL	MIN.	MAX.
A	4.32	5.33
b	0.36	0.47
D	4.45	5.20
E	3.18	4.19
e	2.42	2.66
e1	1.15	1.39
j	3.43	
L	12.70	
S	2.03	2.66

Note:

Information provided by AIC is believed to be accurate and reliable. However, we cannot assume responsibility for use of any circuitry other than circuitry entirely embodied in an AIC product; nor for any infringement of patents or other rights of third parties that may result from its use. We reserve the right to change the circuitry and specifications without notice.

Life Support Policy: AIC does not authorize any AIC product for use in life support devices and/or systems. Life support devices or systems are devices or systems which, (i) are intended for surgical implant into the body or (ii) support or sustain life, and whose failure to perform, when properly used in accordance with instructions for use provided in the labeling, can be reasonably expected to result in a significant injury to the user.