

Silicon NPN Power Transistors

2SD1158

DESCRIPTION

- With TO-220 package
- High speed switching
- High DC current gain
- Low collector saturation voltage

APPLICATIONS

- Switching regulators
- DC-DC converters
- Solid state relay
- General purpose power amplifiers

PINNING

PIN	DESCRIPTION
1	Base
2	Collector;connected to mounting base
3	Emitter

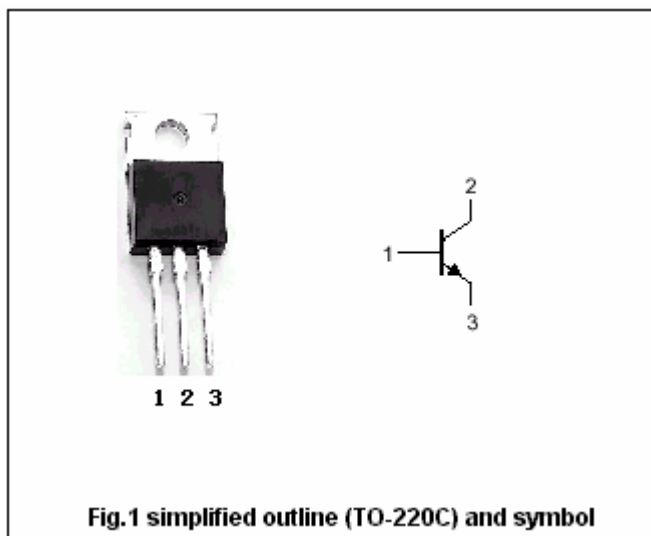

Absolute maximum ratings (Ta=25°C)

SYMBOL	PARAMETER	CONDITIONS	VALUE	UNIT
V_{CBO}	Collector-base voltage	Open emitter	80	V
V_{CEO}	Collector-emitter voltage	Open base	50	V
V_{EBO}	Emitter-base voltage	Open collector	10	V
I_C	Collector current		8	A
I_B	Base current		2	A
P_C	Collector power dissipation	$T_C=25^\circ\text{C}$	40	W
T_j	Junction temperature		150	°C
T_{stg}	Storage temperature		-55~150	°C

THERMAL CHARACTERISTICS

SYMBOL	PARAMETER	VALUE	UNIT
$R_{th\ j-c}$	Thermal resistance junction to case	1.25	°C/W

Silicon NPN Power Transistors

2SD1158

CHARACTERISTICS

T_j=25°C unless otherwise specified

www.datasheet4u.com

SYMBOL	PARAMETER	CONDITIONS	MIN	TYP.	MAX	UNIT
V _{(BR)CEO}	Collector-emitter breakdown voltage	I _C =10mA ; I _B =0	50			V
V _{(BR)CBO}	Collector-base breakdown voltage	I _C =0.1mA ; I _E =0	80			V
V _{(BR)EBO}	Emitter-base breakdown voltage	I _E =0.1mA ; I _C =0	10			V
V _{CEsat}	Collector-emitter saturation voltage	I _C =2A, I _B =0.1A			0.5	V
V _{BEsat}	Base-emitter saturation voltage	I _C =2A, I _B =0.1A			1.5	V
I _{CBO}	Collector cut-off current	V _{CB} =80V; I _E =0			0.1	mA
I _{EBO}	Emitter cut-off current	V _{EB} =10V; I _C =0			0.1	mA
h _{FE}	DC current gain	I _C =1A ; V _{CE} =5V	250			

Switching times

t _{on}	Turn-on time	I _C =5A; I _{B1} =-I _{B2} =0.5A R _L =6Ω P _w = 20μs, Duty≤2%			0.5	μs
t _s	Storage time				3.0	μs
t _f	Fall time				0.8	μs

Silicon NPN Power Transistors

2SD1158

PACKAGE OUTLINE

www.datasheet4u.com

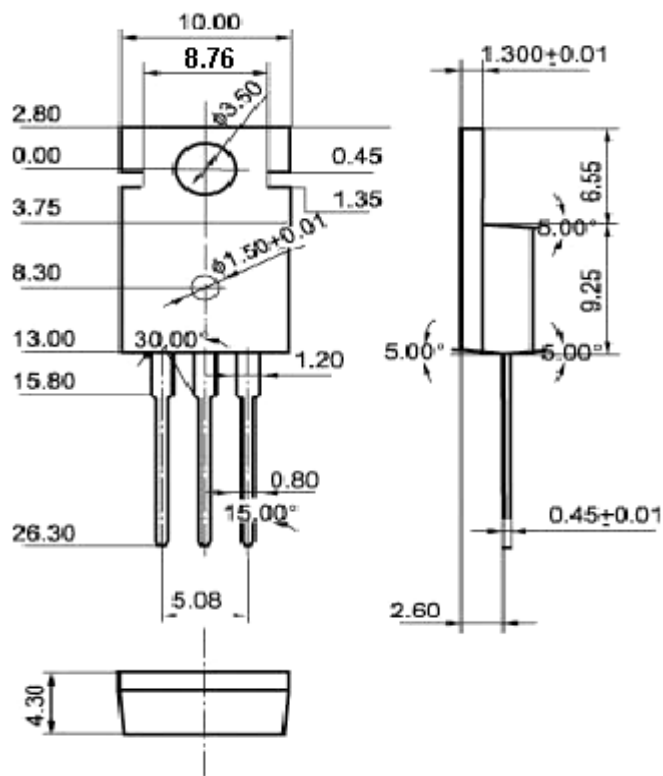

Fig.2 outline dimensions (unindicated tolerance:±0.10 mm)

Silicon NPN Power Transistors

2SD1158

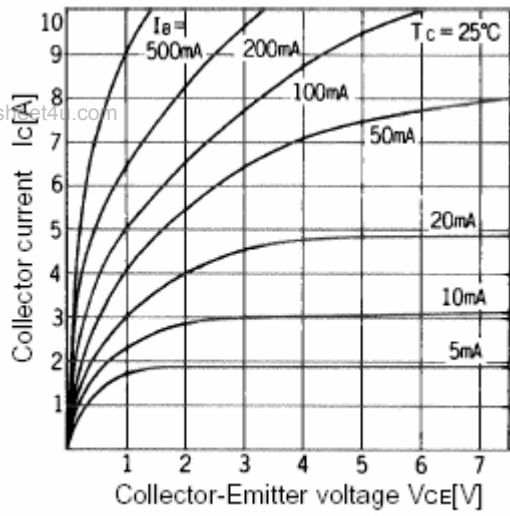

Fig.3 Static Characteristic

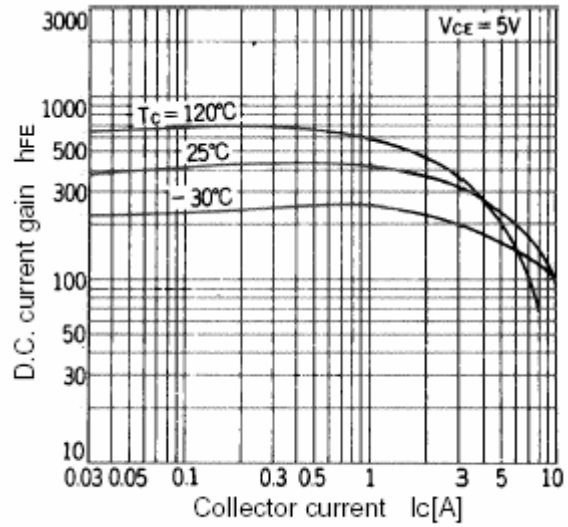

Fig.4 DC current Gain

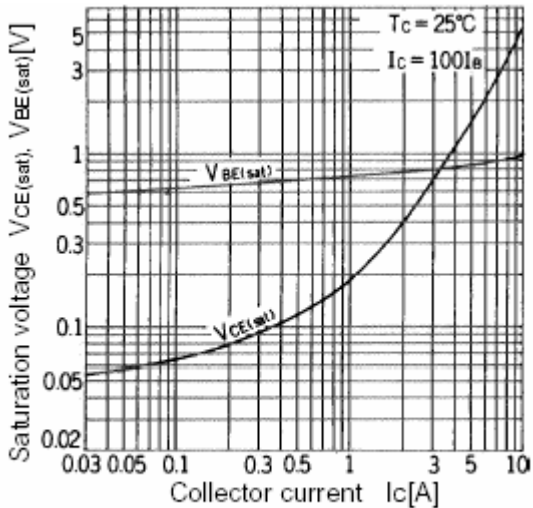

Fig.5 Base-Emitter Saturation Voltage
Collector-Emitter Saturation Voltage

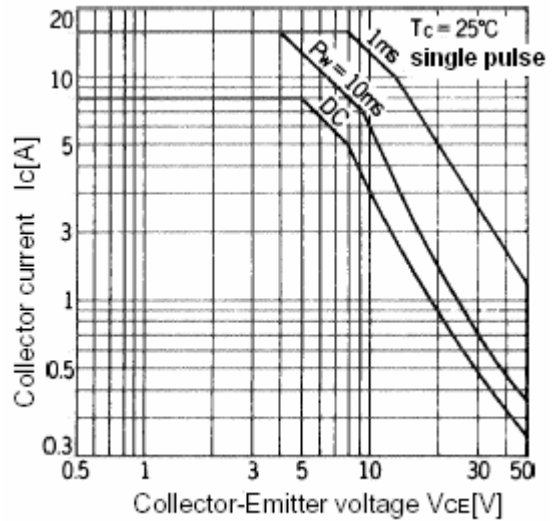

Fig.6 Safe Operating Area