



2SD1628

Preliminary

NPN SILICON TRANSISTOR

HIGH-CURRENT SWITCHING APPLICATIONS

■ FEATURES

- * Low saturation voltage.
- * High h_{FE} .
- * Large current capacity.

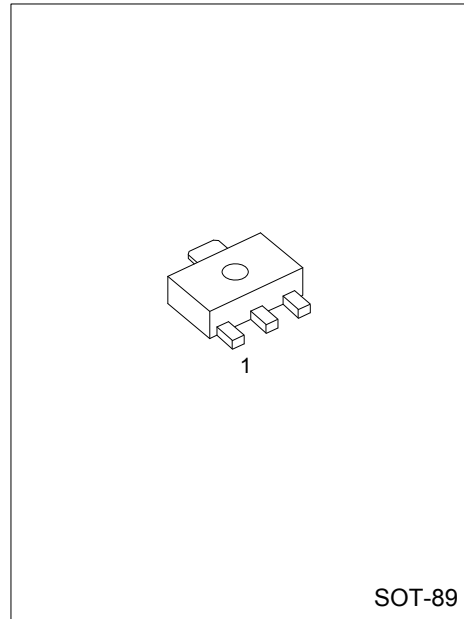

Lead-free: 2SD1628L
 Halogen-free: 2SD1628G

■ ORDERING INFORMATION

Ordering Number			Package	Pin Assignment			Packing
Normal	Lead Free Plating	Halogen Free		1	2	3	
2SD1628-x-AB3-R	2SD1628L-x-AB3-R	2SD1628G-x-AB3-R	SOT-89	B	C	E	Tape Reel

<p>2SD1628L-x-AB3-R</p> <p>(1) Packing Type (2) Package Type (3) Rank (4) Lead Plating</p>	<p>(1) R: Tape Reel (2) AB3: SOT-89 (3) x: refer to Classification of h_{FE1} (4) G: Halogen Free, L: Lead Free Plating, Blank: Pb/Sn</p>
---	---

■ ABSOLUTE MAXIMUM RATINGS (Ta = 25°C)

PARAMETER	SYMBOL	RATINGS	UNIT
Collector-Base Voltage	V_{CBO}	60	V
Collector-Emitter Voltage	V_{CEO}	20	V
Emitter-Base Voltage	V_{EBO}	6	V
Collector Current	DC	I_C	5
	Pulse	I_{CP}	8
Collector Dissipation	P_C	0.5	W
Junction Temperature	T_J	150	°C
Storage Temperature	T_{STG}	-55~+150	°C

Note: Absolute maximum ratings are those values beyond which the device could be permanently damaged.

Absolute maximum ratings are stress ratings only and functional device operation is not implied.

■ ELECTRICAL CHARACTERISTICS (Ta= 25°C, unless otherwise specified)

PARAMETER	SYMBOL	TEST CONDITIONS	MIN	TYP	MAX	UNIT
Collector-Emitter Saturation Voltage	$V_{CE(SAT)}$	$I_C = 3A, I_B = 60mA$			500	mV
Base-Emitter Saturation Voltage	$V_{BE(SAT)}$	$I_C = 3A, I_B = 60mA$			1.5	V
Collector Cut-Off Current	I_{CBO}	$V_{CB} = 50V, I_E = 0$			100	nA
Emitter Cut-Off Current	I_{EBO}	$V_{EB} = 5V, I_C = 0$			100	nA
DC Current Gain	h_{FE1}	$V_{CE} = 2V, I_C = 0.5A$	120		560	
	h_{FE2}	$V_{CE} = 2V, I_C = 3A$	95			
Output Capacitance	C_{ob}	$V_{CB} = 10V, f = 1MHz$		45		pF
Transition Frequency	f_T	$V_{CE} = 10V, I_C = 50mA$		120		MHz
Turn On Time	t_{ON}	See specified Test circuit		30		ns
Storage Time	t_S			300		ns
Fall Time	t_F			40		ns

■ CLASSIFICATION OF h_{FE1}

RANK	E	F	G
RANGE	120 ~ 200	160 ~ 320	280 ~ 560

■ SWITCHING TIME TEST CIRCUIT

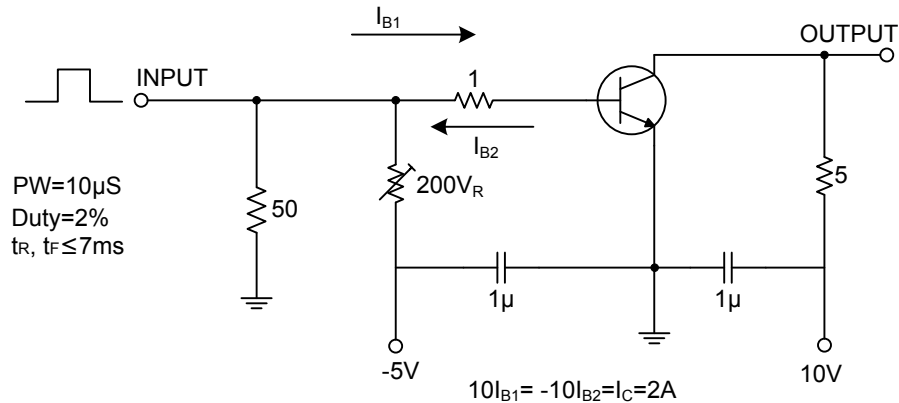

Unit (Resistance:Ω, Capacitance:F)

UTC assumes no responsibility for equipment failures that result from using products at values that exceed, even momentarily, rated values (such as maximum ratings, operating condition ranges, or other parameters) listed in products specifications of any and all UTC products described or contained herein. UTC products are not designed for use in life support appliances, devices or systems where malfunction of these products can be reasonably expected to result in personal injury. Reproduction in whole or in part is prohibited without the prior written consent of the copyright owner. The information presented in this document does not form part of any quotation or contract, is believed to be accurate and reliable and may be changed without notice.