



MX27C2100/27C2048

2M-BIT [256Kx8/128x16] CMOS EPROM

FEATURES

- 128K x 16 organization(MX27C2048, JEDEC pin out)
- 256K x 8 or 128K x 16 organization(MX27C2100, ROM pin out compatible)
- +12.5V programming voltage
- Fast access time: 55/70/90/120/150 ns
- Totally static operation
- Completely TTL compatible
- Operating current: 40mA
- Standby current: 100uA
- Package type:
 - 40 pin plastic DIP
 - 44 pin PLCC(MX27C2048)

GENERAL DESCRIPTION

The MX27C2100/2048 is a 5V only, 2M-bit, One Time Programmable Read Only Memory. It is organized as 128K words by 16 bits per word(MX27C2048), 256K x 8 or 128K x 16(MX27C2100), operates from a single + 5 volt supply, has a static standby mode, and features fast single address location programming. All programming signals are TTL levels, requiring a single pulse. For

programming outside from the system, existing EPROM programmers may be used. The MX27C2100/2048 supports a intelligent fast programming algorithm which can result in programming times of less than one minute.

This EPROM is packaged in industry standard 40 pin dual-in-line package and 44 lead PLCC package.

PIN CONFIGURATIONS

PDIP(MX27C2048)

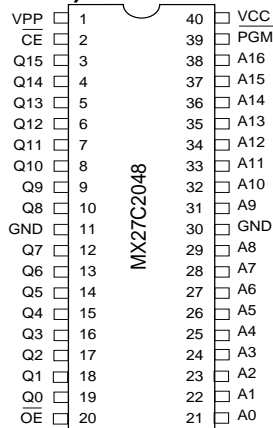

PLCC(MX27C2048)

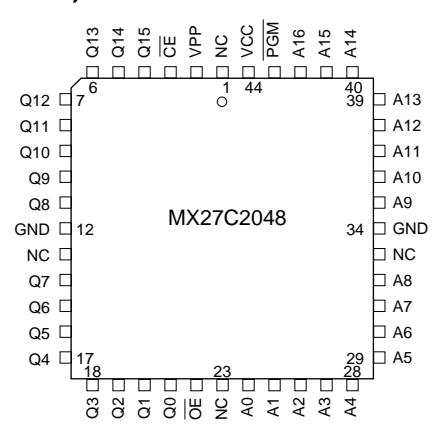

PIN DESCRIPTION(MX27C2048)

| SYMBOL | PIN NAME |
|------------------|------------------------|
| A0-A16 | Address Input |
| Q0-Q15 | Data Input/Output |
| \overline{CE} | Chip Enable Input |
| \overline{OE} | Output Enable Input |
| \overline{PGM} | Program Enable Input |
| VPP | Program Supply Voltage |
| VCC | Power Supply Pin (+5V) |
| GND | Ground Pin |

BLOCK DIAGRAM (MX27C2048)

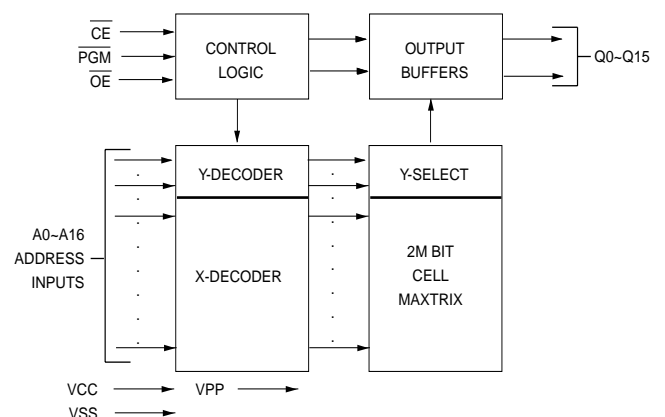



MX27C2100/27C2048

PIN CONFIGURATIONS

PDIP(MX27C2100)

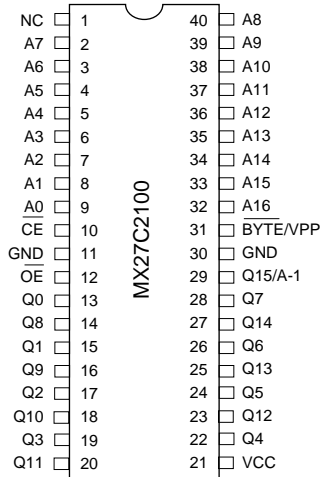

BLOCK DIAGRAM (MX27C2100)

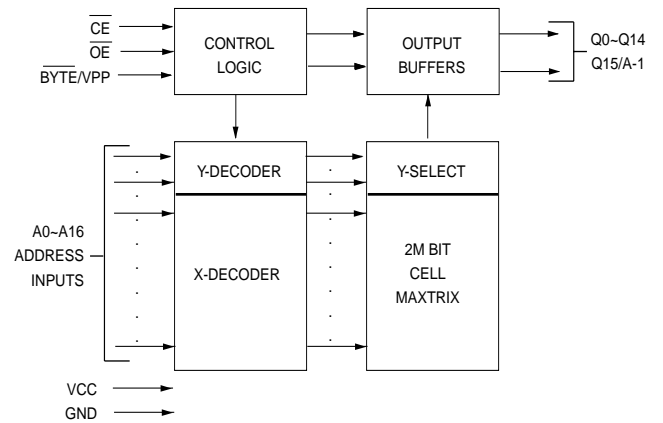

PIN DESCRIPTION(MX27C2100)

| SYMBOL | PIN NAME |
|-----------------------|--|
| A0~A16 | Address Input |
| Q0~Q14 | Data Input/Output |
| \overline{CE} | Chip Enable Input |
| \overline{OE} | Output Enable Input |
| \overline{BYTE}/VPP | Word/Byte Selection /Program Supply Voltage |
| Q15/A-1 | Q15(Word mode)/LSB addr. (Byte mode) |
| VCC | Power Supply Pin (+5V) |
| GND | Ground Pin |

TRUTH TABLE OF BYTE FUNCTION(MX27C2100)

BYTE MODE($\overline{BYTE} = GND$)

| \overline{CE} | \overline{OE} | Q15/A-1 | MODE | Q0-Q7 | SUPPLY CURRENT |
|-----------------|-----------------|-----------|--------------|--------|-----------------|
| H | X | X | Non selected | High Z | Standby(ICC2) |
| L | H | X | Non selected | High Z | Operating(ICC1) |
| L | L | A-1 input | Selected | DOUT | Operating(ICC1) |

WORD MODE($\overline{BYTE} = VCC$)

| \overline{CE} | \overline{OE} | Q15/A-1 | MODE | Q0-Q14 | SUPPLY CURRENT |
|-----------------|-----------------|---------|--------------|--------|-----------------|
| H | X | High Z | Non selected | High Z | Standby(ICC2) |
| L | H | High Z | Non selected | High Z | Operating(ICC1) |
| L | L | DOUT | Selected | DOUT | Operating(ICC1) |

NOTE : X = H or L



MX27C2100/27C2048

FUNCTIONAL DESCRIPTION

THE PROGRAMMING OF THE MX27C2100/2048

When the MX27C2100/2048 is delivered, or it is erased, the chip has all 2M bits in the "ONE", or HIGH state. "ZEROS" are loaded into the MX27C2100/2048 through the procedure of programming.

For programming, the data to be programmed is applied with 16 bits in parallel to the data pins.

VCC must be applied simultaneously or before VPP, and removed simultaneously or after VPP. When programming an MXIC EPROM, a 0.1uF capacitor is required across VPP and ground to suppress spurious voltage transients which may damage the device.

FAST PROGRAMMING

The device is set up in the fast programming mode when the programming voltage $VPP = 12.75V$ is applied, with $VCC = 6.25V$ and $PGM = VIL$ (or $OE = VIH$) (Algorithm is shown in Figure 1). The programming is achieved by applying a single TTL low level 100us pulse to the PGM input after addresses and data line are stable. If the data is not verified, an additional pulse is applied for a maximum of 25 pulses. This process is repeated while sequencing through each address of the device. When the programming mode is completed, the data in all address is verified at $VCC = VPP = 5V \pm 10\%$.

PROGRAM INHIBIT MODE

Programming of multiple MX27C2100/2048's in parallel with different data is also easily accomplished by using the Program Inhibit Mode. Except for \overline{CE} and \overline{OE} , all like inputs of the parallel MX27C2100/2048 may be common. A TTL low-level program pulse applied to an MX27C2100/2048 \overline{CE} input with $VPP = 12.5 \pm 0.5V$ will program the MX27C2100/2048. A high-level \overline{CE} input inhibits the other MX27C2100/2048s from being programmed.

PROGRAM VERIFY MODE

Verification should be performed on the programmed bits to determine that they were correctly programmed. The verification should be performed with \overline{OE} and \overline{CE} at

VIL (for MX27C2048), \overline{OE} at VIL , \overline{CE} at VIH (for MX27C2100) and VPP at its programming voltage.

AUTO IDENTIFY MODE

The auto identify mode allows the reading out of a binary code from an EPROM that will identify its manufacturer and device type. This mode is intended for use by programming equipment for the purpose of automatically matching the device to be programmed with its corresponding programming algorithm. This mode is functional in the $25^{\circ}C \pm 5^{\circ}C$ ambient temperature range that is required when programming the MX27C2100/2048.

To activate this mode, the programming equipment must force $12.0 \pm 0.5V$ on address line A9 of the device. Two identifier bytes may then be sequenced from the device outputs by toggling address line A0 from VIL to VIH . All other address lines must be held at VIL during auto identify mode.

Byte 0 ($A0 = VIL$) represents the manufacturer code, and byte 1 ($A0 = VIH$), the device identifier code. For the MX27C2100/2048, these two identifier bytes are given in the Mode Select Table. All identifiers for manufacturer and device codes will possess odd parity, with the MSB (Q15) defined as the parity bit.

READ MODE

The MX27C2100/2048 has two control functions, both of which must be logically satisfied in order to obtain data at the outputs. Chip Enable (\overline{CE}) is the power control and should be used for device selection. Output Enable (\overline{OE}) is the output control and should be used to gate data to the output pins, independent of device selection. Assuming that addresses are stable, address access time (t_{ACC}) is equal to the delay from \overline{CE} to output (t_{CE}). Data is available at the outputs t_{OE} after the falling edge of \overline{OE} 's, assuming that \overline{CE} has been LOW and addresses have been stable for at least $t_{ACC} - t_{OE}$.

WORD-WIDE MODE

With $BYTE/VPP$ at $VCC \pm 0.2V$ outputs Q0-7 present data Q0-7 and outputs Q8-15 present data Q8-15, after \overline{CE} and \overline{OE} are appropriately enabled.



BYTE-WIDE MODE

With BYTE/VPP at $GND \pm 0.2V$, outputs Q8-15 are tri-stated. If $Q15/A-1 = VIH$, outputs Q0-7 present data bits Q8-15. If $Q15/A-1 = VIL$, outputs Q0-7 present data bits Q0-7.

The location of the capacitor should be close to where the power supply is connected to the array.

STANDBY MODE

The MX27C2100/2048 has a CMOS standby mode which reduces the maximum VCC current to 100 μA . It is placed in CMOS standby when \overline{CE} is at $VCC \pm 0.3 V$. The MX27C2100/2048 also has a TTL-standby mode which reduces the maximum VCC current to 1.5 mA. It is placed in TTL-standby when \overline{CE} is at VIH . When in standby mode, the outputs are in a high-impedance state, independent of the \overline{OE} input.

TWO-LINE OUTPUT CONTROL FUNCTION

To accommodate multiple memory connections, a two-line control function is provided to allow for:

1. Low memory power dissipation,
2. Assurance that output bus contention will not occur.

It is recommended that \overline{CE} be decoded and used as the primary device-selecting function, while \overline{OE} be made a common connection to all devices in the array and connected to the READ line from the system control bus. This assures that all deselected memory devices are in their low-power standby mode and that the output pins are only active when data is desired from a particular memory device.

SYSTEM CONSIDERATIONS

During the switch between active and standby conditions, transient current peaks are produced on the rising and falling edges of Chip Enable. The magnitude of these transient current peaks is dependent on the output capacitance loading of the device. At a minimum, a 0.1 μF ceramic capacitor (high frequency, low inherent inductance) should be used on each device between Vcc and GND to minimize transient effects. In addition, to overcome the voltage drop caused by the inductive effects of the printed circuit board traces on EPROM arrays, a 4.7 μF bulk electrolytic capacitor should be used between VCC and GND for each eight devices.



MX27C2100/27C2048

MODE SELECT TABLE (MX27C2048)

| MODE | PINS | | | | | | OUTPUTS |
|----------------------|-----------------|-----------------|------------------|-----|----|-----|---------|
| | \overline{CE} | \overline{OE} | \overline{PGM} | A0 | A9 | VPP | |
| Read | VIL | VIL | VIH | X | X | VCC | DOUT |
| Output Disable | VIL | VIH | VIH | X | X | VCC | High Z |
| Standby (TTL) | VIH | X | X | X | X | VCC | High Z |
| Standby (CMOS) | VCC±0.3V | X | X | X | X | VCC | High Z |
| Program | VIL | VIH | VIL | X | X | VPP | DIN |
| Program Verify | VIL | VIL | VIH | X | X | VPP | DOUT |
| Program Inhibit | VIH | X | X | X | X | VPP | High Z |
| Manufacturer Code(3) | VIL | VIL | X | VIL | VH | VCC | 00C2H |
| Device Code(3) | VIL | VIL | X | VIH | VH | VCC | 0122H |

NOTES: 1. VH = 12.0 V ± 0.5 V
2. X = Either VIH or VIL

3. A1 - A8 = A10 - A16 = VIL(For auto select)
4. See DC Programming Characteristics for VPP voltage during programming.

MODE SELECT TABLE (MX27C2100)

| MODE | BYTE/ | | | | | | | |
|----------------------|-----------------|-----------------|----|-----|---------|--------|-----------|-----------|
| | \overline{CE} | \overline{OE} | A9 | A0 | Q15/A-1 | VPP(5) | Q8-14 | Q0-7 |
| Read (Word) | VIL | VIL | X | X | Q15 Out | VCC | Q8-14 Out | Q0-7 Out |
| Read (Upper Byte) | VIL | VIL | X | X | VIH | GND | High Z | Q8-15 Out |
| Read (Lower Byte) | VIL | VIL | X | X | VIL | GND | High Z | Q0-7 Out |
| Output Disable | VIL | VIH | X | X | High Z | X | High Z | High Z |
| Standby | VIH | X | X | X | High Z | X | High Z | High Z |
| Program | VIL | VIH | X | X | Q15 In | VPP | Q8-14 In | Q0-7 In |
| Program Verify | VIH | VIL | X | X | Q15 Out | VPP | Q8-14 Out | Q0-7 Out |
| Program Inhibit | VIH | VIH | X | X | High Z | VPP | High Z | High Z |
| Manufacturer Code(3) | VIL | VIL | VH | VIL | 0B | VCC | 00H | C2H |
| Device Code(3) | VIL | VIL | VH | VIH | 0B | VCC | 01H | 8AH |

NOTES: 1. VH = 12.0V ± 0.5V
2. X = Either VIH or VIL.
3. A1 - A8, A10 - A16 = VIL(For auto select)

4. See DC Programming Characteristics for VPP voltages.
5. BYTE/VPP is intended for operation under DC Voltage conditions only.

FIGURE 1. FAST PROGRAMMING FLOW CHART

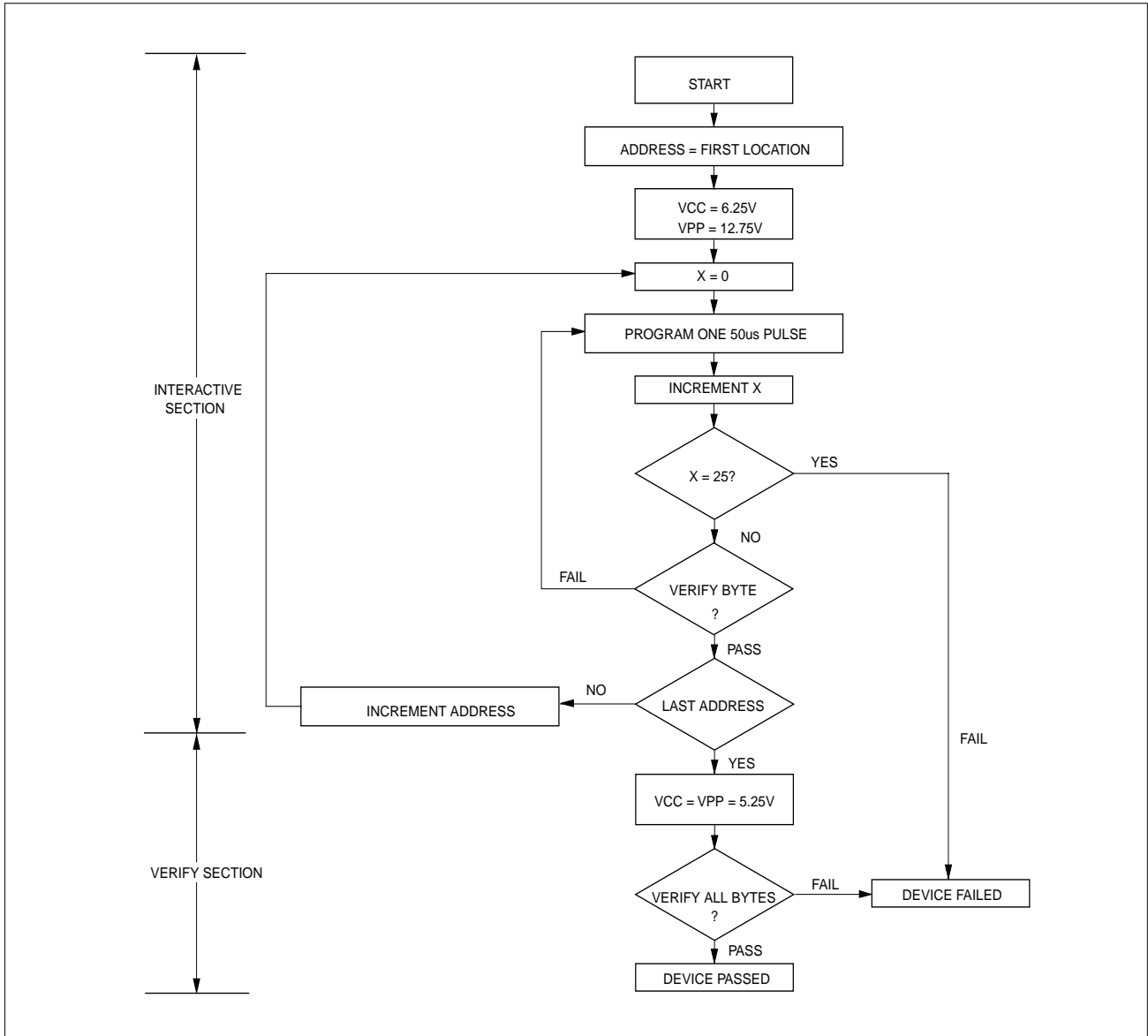

SWITCHING TEST CIRCUITS

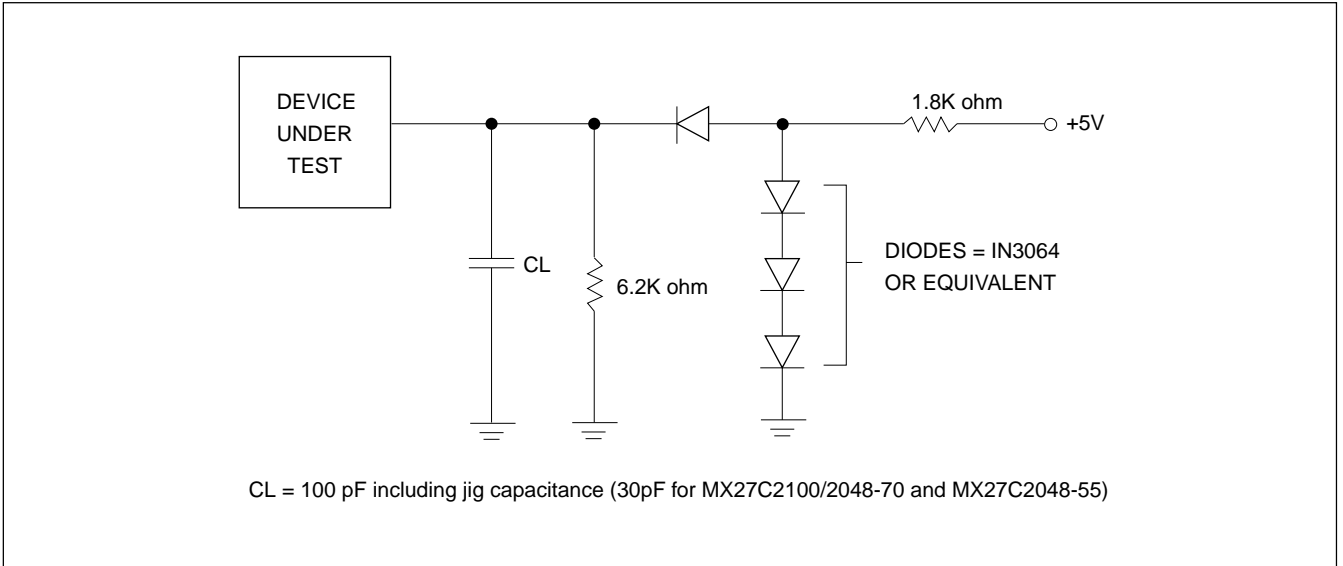

SWITCHING TEST WAVEFORMS

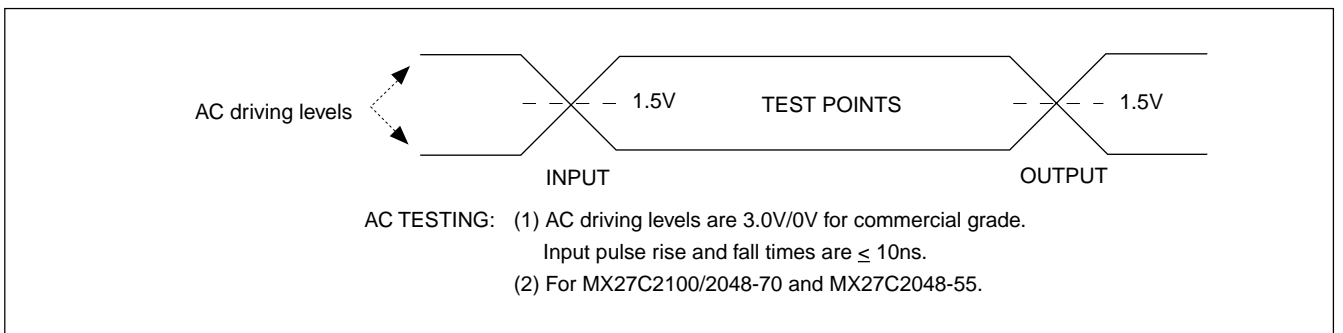
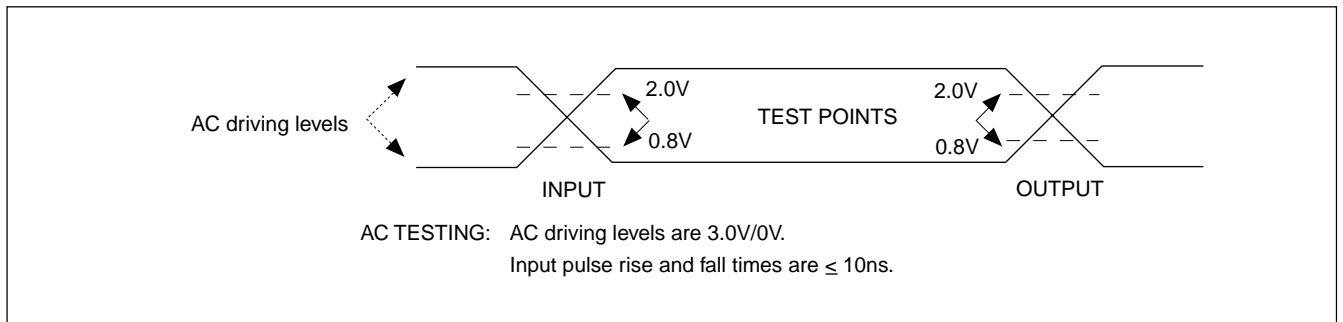



MX27C2100/27C2048

ABSOLUTE MAXIMUM RATINGS

| RATING | VALUE |
|-------------------------------|---------------------|
| Ambient Operating Temperature | 0°C to 70°C |
| Storage Temperature | -65°C to 125°C |
| Applied Input Voltage | -0.5V to 7.0V |
| Applied Output Voltage | -0.5V to VCC + 0.5V |
| VCC to Ground Potential | -0.5V to 7.0V |
| A9 & Vpp | -0.5V to 13.5V |

NOTICE:

Stresses greater than those listed under ABSOLUTE MAXIMUM RATINGS may cause permanent damage to the device. This is a stress rating only and functional operation of the device at these or any other conditions above those indicated in the operational sections of this specification is not implied. Exposure to absolute maximum rating conditions for extended period may affect reliability.

NOTICE:

Specifications contained within the following tables are subject to change.

DC/AC Operating Conditions for Read Operation

| | | MX27C2048 | | MX27C2100/2048 | | |
|-----------------------|------------|-------------|-------------|----------------|-------------|-------------|
| | | -55 | -70 | -90 | -12 | -15 |
| Operating Temperature | Commercial | 0°C to 70°C | 0°C to 70°C | 0°C to 70°C | 0°C to 70°C | 0°C to 70°C |
| Vcc Power Supply | | 5V ± 10% | 5V ± 10% | 5V ± 10% | 5V ± 10% | 5V ± 10% |

DC CHARACTERISTICS

| SYMBOL | PARAMETER | MIN. | MAX. | UNIT | CONDITIONS |
|--------|-------------------------|------|-----------|------|---|
| VOH | Output High Voltage | 2.4 | | V | IOH = -0.4mA |
| VOL | Output Low Voltage | | 0.4 | V | IOL = 2.1mA |
| VIH | Input High Voltage | 2.0 | VCC + 0.5 | V | |
| VIL | Input Low Voltage | -0.3 | 0.8 | V | |
| ILI | Input Leakage Current | -10 | 10 | µA | VIN = 0 to 5.5V |
| ILO | Output Leakage Current | -10 | 10 | µA | VOUT = 0 to 5.5V |
| ICC3 | VCC Power-Down Current | | 100 | µA | $\overline{CE} = VCC \pm 0.3V$ |
| ICC2 | VCC Standby Current | | 1.5 | mA | $\overline{CE} = VIH$ |
| ICC1 | VCC Active Current | | 40 | mA | $\overline{CE} = VIL, f=5MHz, Iout = 0mA$ |
| IPP | VPP Supply Current Read | | 10 | µA | $\overline{CE} = \overline{OE} = VIL, VPP = 5.5V$ |

CAPACITANCE TA = 25°C, f = 1.0 MHz (Sampled only)

| SYMBOL | PARAMETER | TYP. | MAX. | UNIT | CONDITIONS |
|--------|--------------------|------|------|------|------------|
| CIN | Input Capacitance | 8 | 12 | pF | VIN = 0V |
| COUT | Output Capacitance | 8 | 12 | pF | VOUT = 0V |
| CVPP | VPP Capacitance | 18 | 25 | pF | VPP = 0V |



MX27C2100/27C2048

AC CHARACTERISTICS

| SYMBOL | PARAMETER | 2100/2048-55 | | 2100/2048-70 | | 2100/2048-90 | | UNIT | CONDITIONS |
|--------|---|--------------|------|--------------|------|--------------|------|------|---------------------------------------|
| | | MIN. | MAX. | MIN. | MAX. | MIN. | MAX. | | |
| tACC | Address to Output Delay | | 55 | | 70 | | 90 | ns | $\overline{CE} = \overline{OE} = VIL$ |
| tCE | Chip Enable to Output Delay | | 55 | | 70 | | 90 | ns | $\overline{OE} = VIL$ |
| tOE | Output Enable to Output Delay | | 30 | | 30 | | 40 | ns | $\overline{CE} = VIL$ |
| tDF | \overline{OE} High to Output Float, or \overline{CE} High to Output Float | 0 | 15 | 0 | 15 | 0 | 25 | ns | |
| tOH | Output Hold from Address, \overline{CE} or \overline{OE} which ever occurred first | 0 | | 0 | | 0 | | ns | |

AC CHARACTERISTICS

| SYMBOL | PARAMETER | 2100/2048-12 | | 2100/2048-15 | | UNIT | CONDITIONS |
|--------|---|--------------|------|--------------|------|------|---------------------------------------|
| | | MIN. | MAX. | MIN. | MAX. | | |
| tACC | Address to Output Delay | | 120 | | 150 | ns | $\overline{CE} = \overline{OE} = VIL$ |
| tCE | Chip Enable to Output Delay | | 120 | | 150 | ns | $\overline{OE} = VIL$ |
| tOE | Output Enable to Output Delay | | 50 | | 65 | ns | $\overline{CE} = VIL$ |
| tDF | \overline{OE} High to Output Float, or \overline{CE} High to Output Float | 0 | 35 | 0 | 50 | ns | |
| tOH | Output Hold from Address, \overline{CE} or \overline{OE} which ever occurred first | 0 | | 0 | | ns | |

AC CHARACTERISTICS

| SYMBOL | PARAMETER | 27C2100-70 | | 27C2100-90 | | 27C2100-12 | | 27C2100-15 | | UNIT |
|--------|-------------------------------------|------------|------|------------|------|------------|------|------------|------|------|
| | | MIN. | MAX. | MIN. | MAX. | MIN. | MAX. | MIN. | MAX. | |
| tBHA | \overline{BYTE} Access Time | | 70 | | 90 | | 120 | | 150 | ns |
| tOHB | \overline{BYTE} Output Hold Time | 0 | | 0 | | 0 | | 0 | | ns |
| tBHZ | \overline{BYTE} Output Delay Time | | 70 | | 70 | | 70 | | 70 | ns |
| tBLZ | \overline{BYTE} Output Set Time | 10 | | 10 | | 10 | | 10 | | ns |



MX27C2100/27C2048

DC PROGRAMMING CHARACTERISTICS TA = 25°C ± 5°C

| SYMBOL | PARAMETER | MIN. | MAX. | UNIT | CONDITIONS |
|--------|---------------------------------------|------|-----------|------|--|
| VOH | Output High Voltage | 2.4 | | V | IOH = -0.40mA |
| VOL | Output Low Voltage | | 0.4 | V | IOL = 2.1mA |
| VIH | Input High Voltage | 2.0 | VCC + 0.5 | V | |
| VIL | Input Low Voltage | -0.3 | 0.8 | V | |
| ILI | Input Leakage Current | -10 | 10 | uA | VIN = 0 to 5.5V |
| VH | A9 Auto Select Voltage | 11.5 | 12.5 | V | |
| ICC3 | VCC Supply Current (Program & Verify) | | 50 | mA | |
| IPP2 | VPP Supply Current(Program) | | 30 | mA | $\overline{CE} = VIL, \overline{OE} = VIH$ |
| VCC1 | Fast Programming Supply Voltage | 6.00 | 6.50 | V | |
| VPP1 | Fast Programming Voltage | 12.5 | 13.0 | V | |

AC PROGRAMMING CHARACTERISTICS TA = 25°C ± 5°C

| SYMBOL | PARAMETER | MIN. | MAX. | UNIT | CONDITIONS |
|--------|--------------------------------------|------|------|------|------------|
| tAS | Address Setup Time | 2.0 | | us | |
| tOES | \overline{OE} Setup Time | 2.0 | | us | |
| tDS | Data Setup Time | 2.0 | | us | |
| tAH | Address Hold Time | 0 | | us | |
| tDH | Data Hold Time | 2.0 | | us | |
| tDFP | Out put Enable to Output Float Delay | 0 | 130 | ns | |
| tVPS | VPP Setup Time | 2.0 | | us | |
| tPW | \overline{PGM} Program Pulse Width | 95 | 105 | us | |
| tVCS | VCC Setup Time | 2.0 | | us | |
| tCES | \overline{CE} Setup Time | 2.0 | | us | |
| tOE | Data valid from \overline{OE} | | 150 | ns | |



MX27C2100/27C2048

WAVEFORMS(MX27C2048) READ CYCLE (WORD MODE)

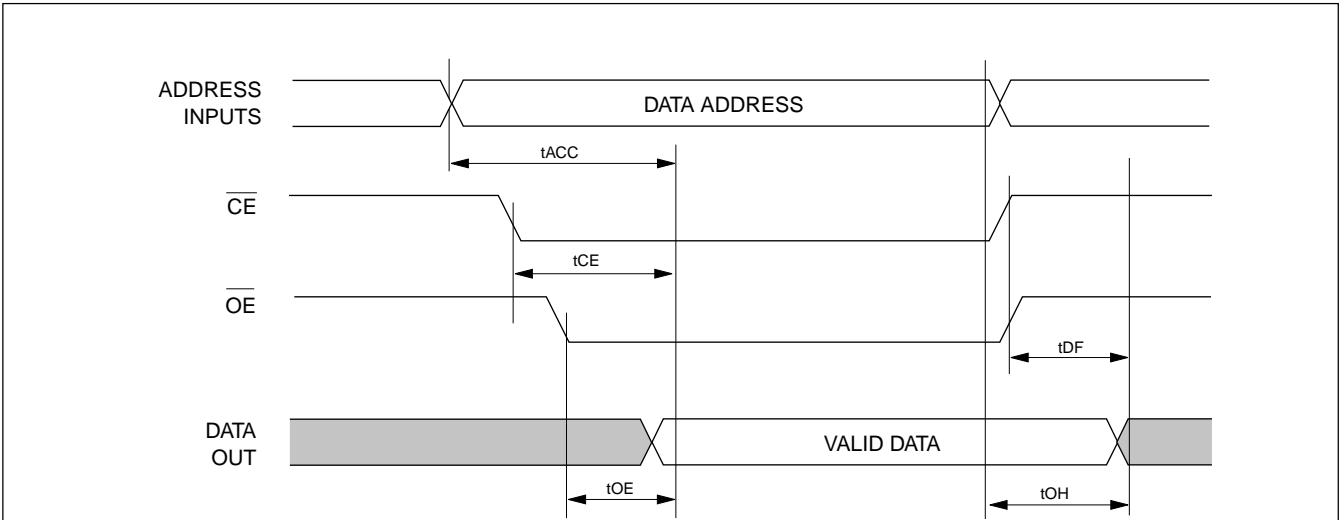

FAST PROGRAMMING ALGORITHM WAVEFORM

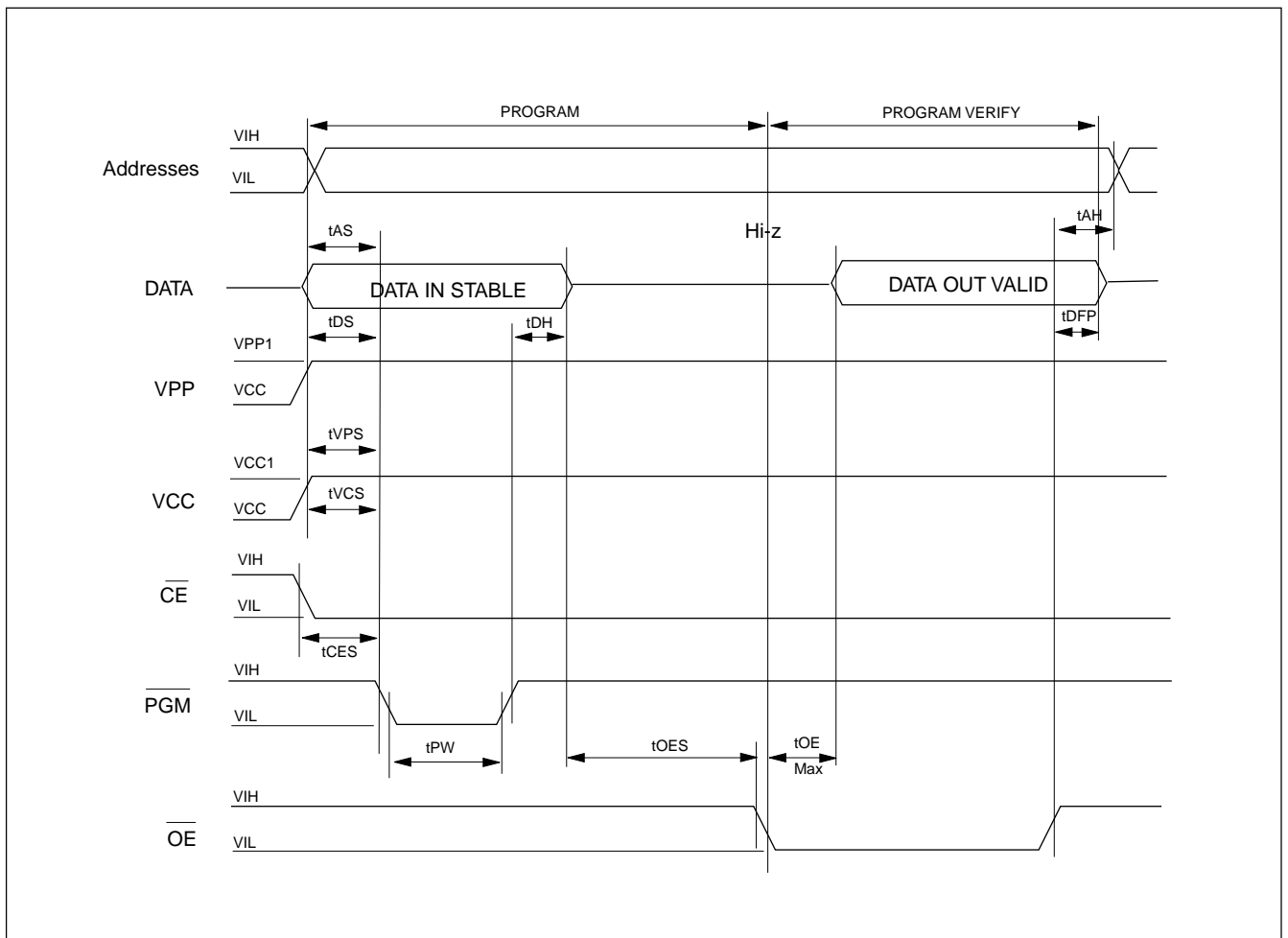

WAVEFORMS(MX27C2100) READ CYCLE (BYTE MODE)

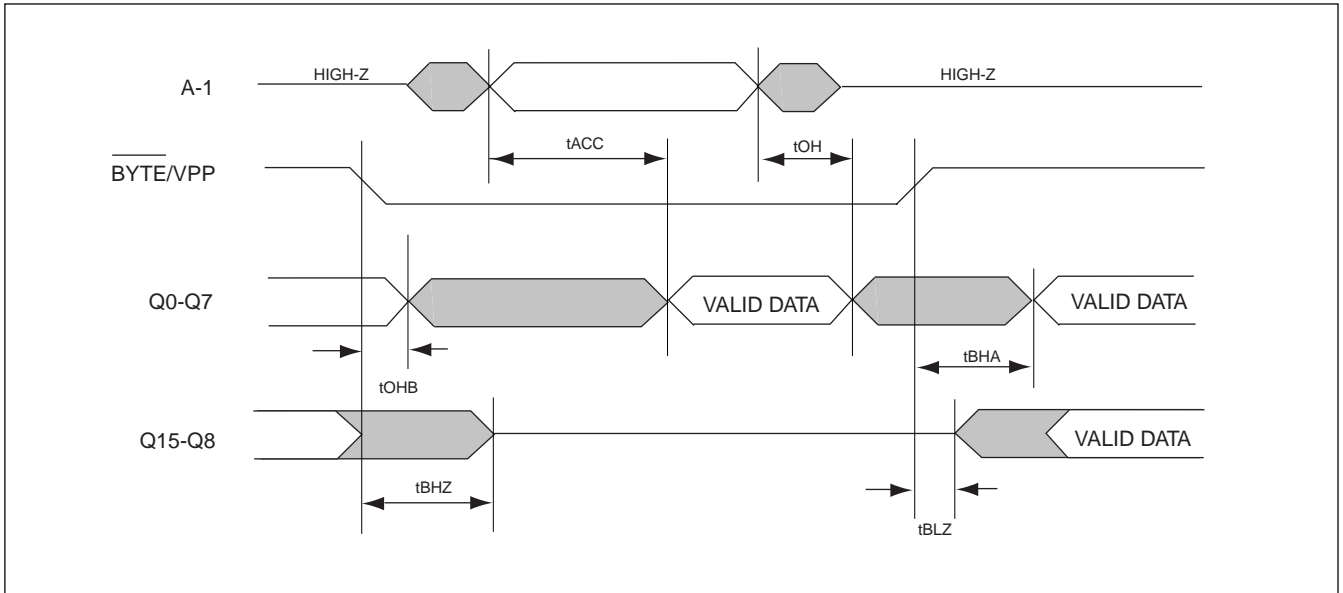

FAST PROGRAMMING ALGORITHM WAVEFORM

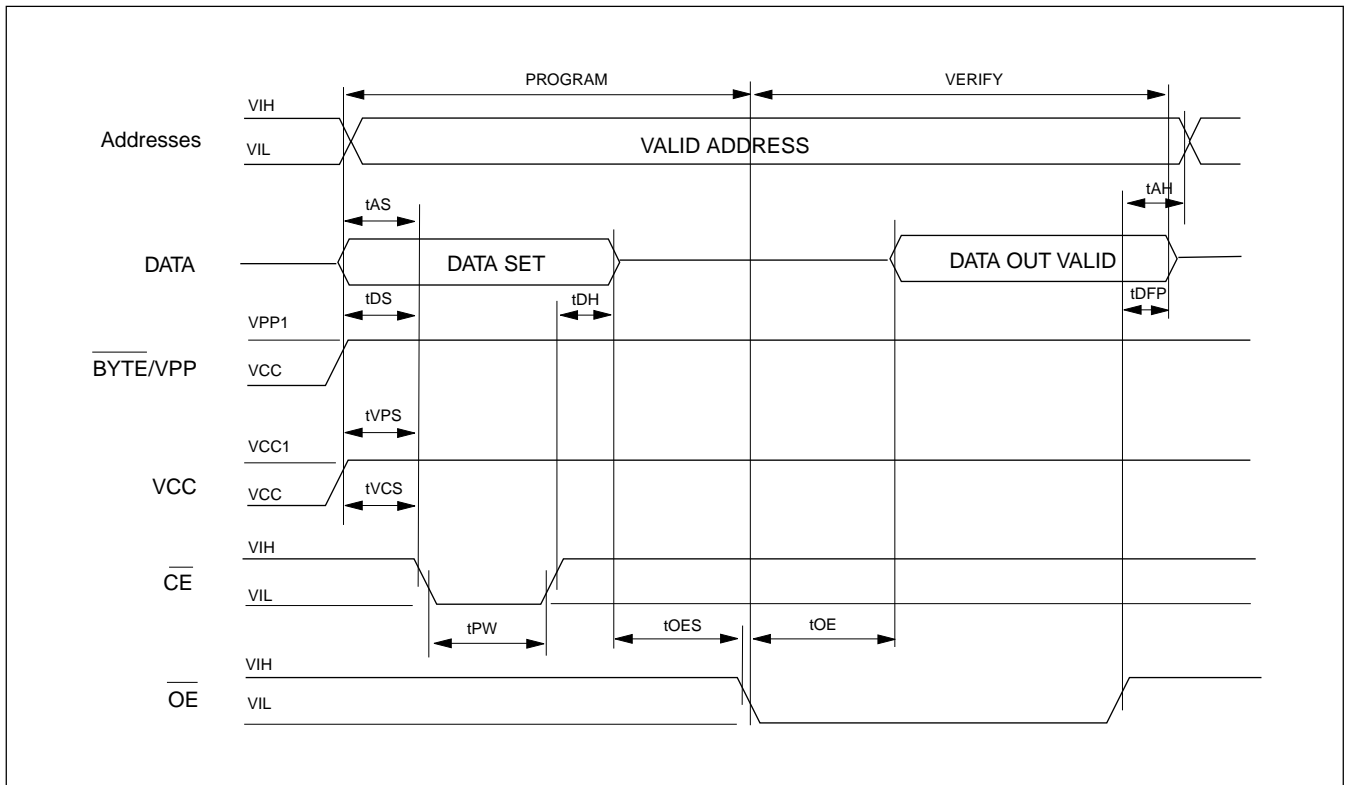



MX27C2100/27C2048

ORDERING INFORMATION

PLASTIC PACKAGE

| PART NO. | ACCESS TIME | OPERATING CURRENT | STANDBY CURRENT | PACKAGE |
|----------------|-------------|-------------------|-----------------|---------------------------|
| | (ns) | MAX.(mA) | MAX.(uA) | |
| MX27C2100PC-70 | 70 | 40 | 100 | 40 Pin DIP(ROM pin out) |
| MX27C2100PC-90 | 90 | 40 | 100 | 40 Pin DIP(ROM pin out) |
| MX27C2100PC-12 | 120 | 40 | 100 | 40 Pin DIP(ROM pin out) |
| MX27C2100PC-15 | 150 | 40 | 100 | 40 Pin DIP(ROM pin out) |
| MX27C2048PC-55 | 55 | 40 | 100 | 40 Pin DIP(JEDEC pin out) |
| MX27C2048PC-70 | 70 | 40 | 100 | 40 Pin DIP(JEDEC pin out) |
| MX27C2048PC-90 | 90 | 40 | 100 | 40 Pin DIP(JEDEC pin out) |
| MX27C2048PC-12 | 120 | 40 | 100 | 40 Pin DIP(JEDEC pin out) |
| MX27C2048PC-15 | 150 | 40 | 100 | 40 Pin DIP(JEDEC pin out) |
| MX27C2048QC-55 | 55 | 40 | 100 | 44 Pin PLCC |
| MX27C2048QC-70 | 70 | 40 | 100 | 44 Pin PLCC |
| MX27C2048QC-90 | 90 | 40 | 100 | 44 Pin PLCC |
| MX27C2048QC-12 | 120 | 40 | 100 | 44 Pin PLCC |
| MX27C2048QC-15 | 150 | 40 | 100 | 44 Pin PLCC |



MX27C2100/27C2048

PACKAGE INFORMATION

Title: Package Outline for PDIP 40L(600MIL)

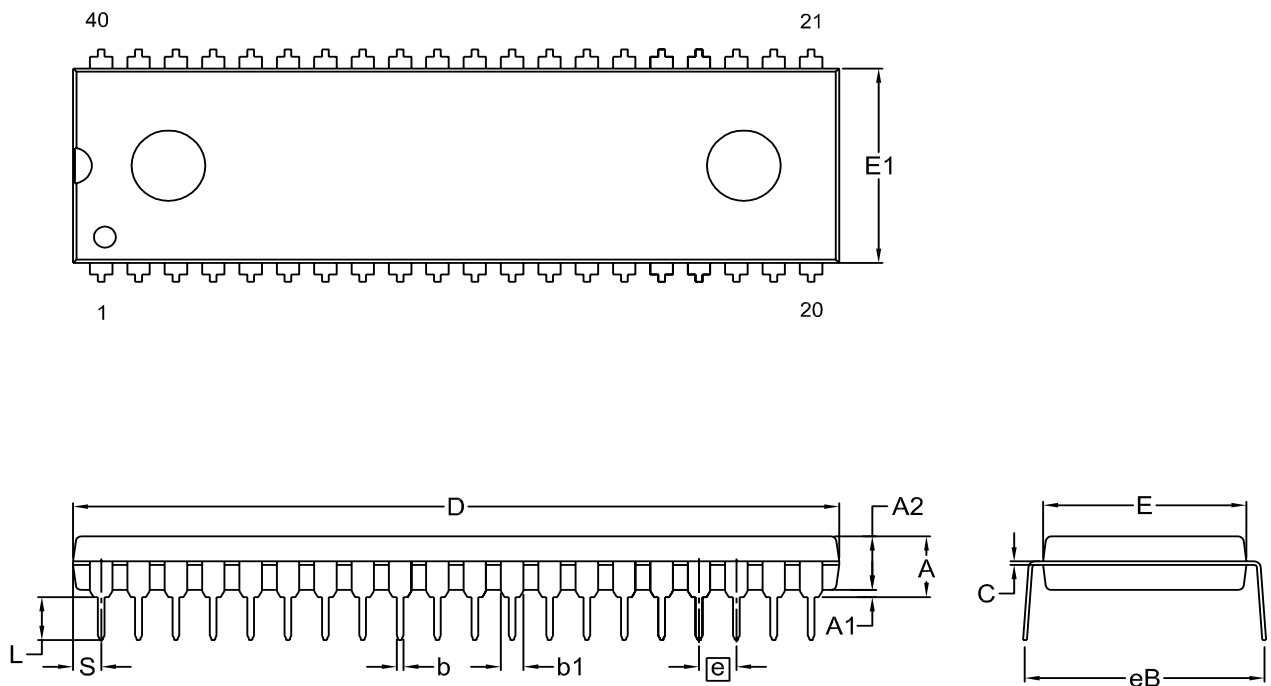

Dimensions (inch dimensions are derived from the original mm dimensions)

| SYMBOL | | A | A1 | A2 | b | b1 | C | D | E | E1 | e | eB | L | S |
|--------|------|-------|-------|-------|-------|-------|-------|-------|-------|-------|-------|-------|-------|-------|
| UNIT | | | | | | | | | | | | | | |
| mm | Min. | — | 0.25 | 3.73 | 0.38 | 1.14 | 0.20 | 51.31 | 15.11 | 13.84 | | 15.75 | 2.92 | 1.65 |
| | Nom. | — | --- | 3.94 | 0.46 | 1.27 | 0.25 | 51.94 | 15.24 | 13.97 | 2.54 | 16.51 | 3.30 | 1.90 |
| | Max. | 4.90 | 0.76 | 4.14 | 0.53 | 1.40 | 0.30 | 52.57 | 15.37 | 14.10 | | 17.27 | 3.68 | 2.16 |
| Inch | Min. | --- | 0.010 | 0.147 | 0.015 | 0.045 | 0.008 | 2.020 | 0.595 | 0.545 | | 0.620 | 0.115 | 0.065 |
| | Nom. | --- | --- | 0.155 | 0.018 | 0.050 | 0.010 | 2.045 | 0.600 | 0.550 | 0.100 | 0.650 | 0.130 | 0.075 |
| | Max. | 0.193 | 0.030 | 0.163 | 0.021 | 0.055 | 0.012 | 2.070 | 0.605 | 0.555 | | 0.680 | 0.145 | 0.085 |

| DWG.NO. | REVISION | REFERENCE | | | ISSUE DATE |
|-------------|----------|-----------|------|--|------------|
| | | JEDEC | EIAJ | | |
| 6110-0202.4 | 6 | | | | 11-19-02 |

Title: Package Outline for 44L PLCC

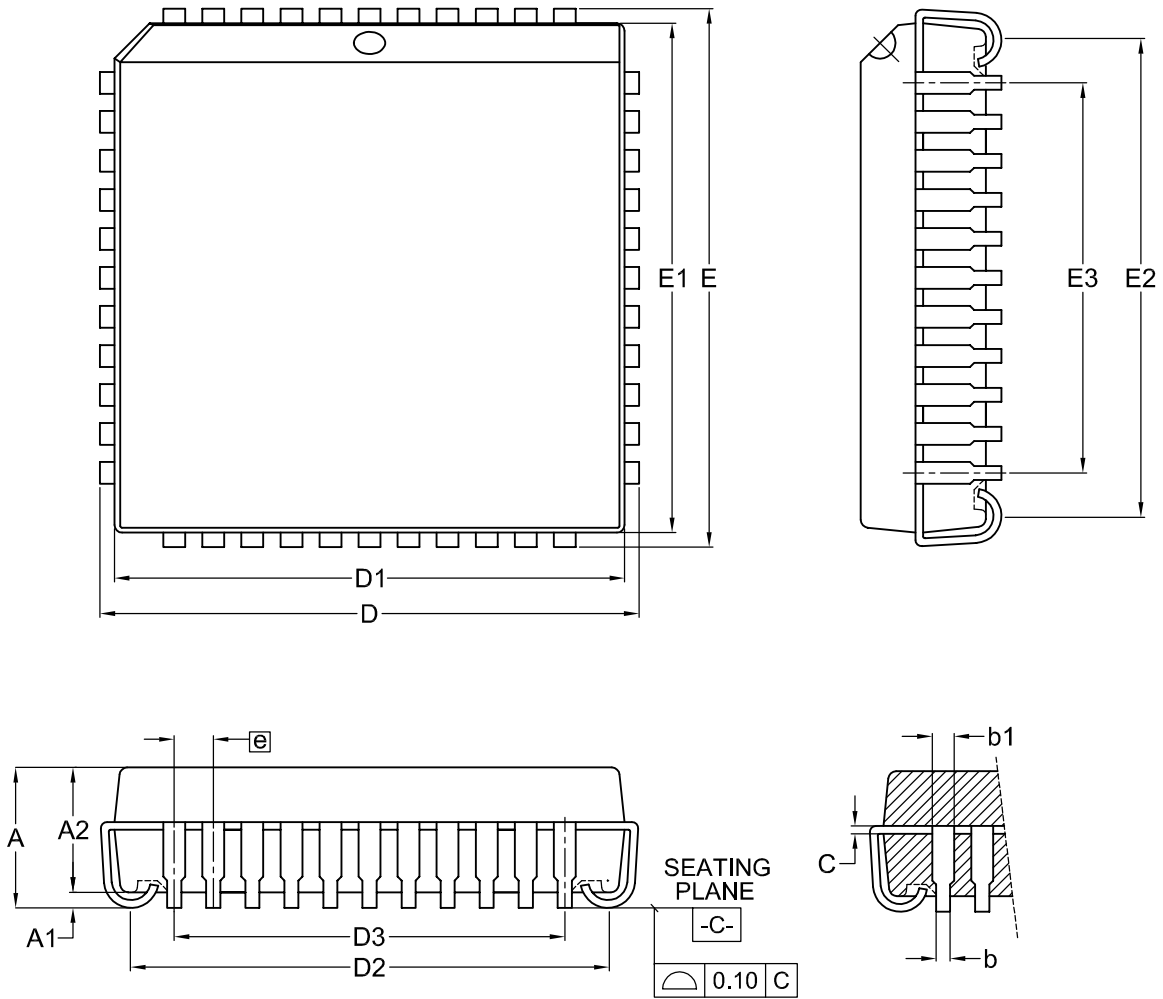

Dimensions (inch dimensions are derived from the original mm dimensions)

| SYMBOL | | A | A1 | A2 | b | b1 | C | D | D1 | D2 | D3 | E | E1 | E2 | E3 | e |
|--------|------|-------|-------|-------|-------|-------|-------|-------|-------|-------|-------|-------|-------|-------|-------|-------|
| UNIT | | | | | | | | | | | | | | | | |
| mm | Min. | --- | 0.38 | 3.71 | 0.38 | 0.61 | 0.20 | 17.40 | 16.52 | 15.19 | | 17.40 | 16.52 | 15.19 | | |
| | Nom. | --- | 0.50 | 3.81 | 0.46 | 0.71 | 0.25 | 17.53 | 16.59 | 15.49 | 12.70 | 17.53 | 16.59 | 15.49 | 12.70 | 1.27 |
| | Max. | 4.57 | 0.66 | 3.91 | 0.54 | 0.81 | 0.30 | 17.66 | 16.66 | 15.79 | | 17.66 | 16.66 | 15.79 | | |
| Inch | Min. | — | 0.015 | 0.146 | 0.015 | 0.024 | 0.008 | 0.685 | 0.650 | 0.598 | | 0.685 | 0.650 | 0.598 | | |
| | Nom. | — | 0.020 | 0.150 | 0.018 | 0.028 | 0.010 | 0.690 | 0.653 | 0.610 | 0.500 | 0.690 | 0.653 | 0.610 | 0.500 | 0.050 |
| | Max. | 0.180 | 0.026 | 0.154 | 0.021 | 0.032 | 0.012 | 0.695 | 0.656 | 0.622 | | 0.695 | 0.656 | 0.622 | | |

| DWG.NO. | REVISION | REFERENCE | | | ISSUE DATE |
|-----------|----------|-----------|------|--|------------|
| | | JEDEC | EIAJ | | |
| 6110-2003 | 4 | MS-016 | | | 09-24-'02 |



REVISION HISTORY

| Revision No. | Description | Page | Date |
|---------------------|---|-----------------|-------------|
| 3.0 | SWITCHING TEST WAVEFORMS: For 90/120/150ns, the AC driving level are revised from 2.4V/0.4V to 3.0V/0V. | | 10/23/1996 |
| 4.0 | 1)Eliminate Interactive Programming Mode. 2)40-CDIP package quartz len, change to square shape. | | 6/13/1997 |
| 4.1 | IPP : 100uA----> 10uA | | 8/8/1997 |
| 4.2 | Cancel Ceramic DIP package type | P1,2,3,13,14 | MAR/01/2000 |
| 4.3 | Cancel "Ultraviolet Erasable" wording in General Description To modify Package Information | P1 P14~16 | AUG/22/2001 |
| 4.4 | To modify Package Information | P14~16 | NOV/19/2002 |
| 4.5 | 1. To remove 10 x 14mm 40-TSOP package type. 2. To modify 40-PDIP package information | P1,13,16 P14 | JAN/14/2003 |



MX27C2100/27C2048

MACRONIX INTERNATIONAL Co., LTD.

HEADQUARTERS:

TEL:+886-3-578-6688

FAX:+886-3-563-2888

EUROPE OFFICE:

TEL:+32-2-456-8020

FAX:+32-2-456-8021

JAPAN OFFICE:

TEL:+81-44-246-9100

FAX:+81-44-246-9105

SINGAPORE OFFICE:

TEL:+65-348-8385

FAX:+65-348-8096

TAIPEI OFFICE:

TEL:+886-2-2509-3300

FAX:+886-2-2509-2200

MACRONIX AMERICA, INC.

TEL:+1-408-453-8088

FAX:+1-408-453-8488

CHICAGO OFFICE:

TEL:+1-847-963-1900

FAX:+1-847-963-1909

[http : //www.macronix.com](http://www.macronix.com)