

Features

- High Dynamic Range for AM and FM
- Integrated AGC for FM
- High Intercept Point 3rd-order for FM
- FM Amplifier Adjustable to Various Cable Impedances
- High Intercept Point 2nd-order for AM
- Low-noise Output Voltage
- Low Power Consumption



Low-noise AM/FM Antenna Impedance Matching IC

Electrostatic sensitive device.
Observe precautions for handling.

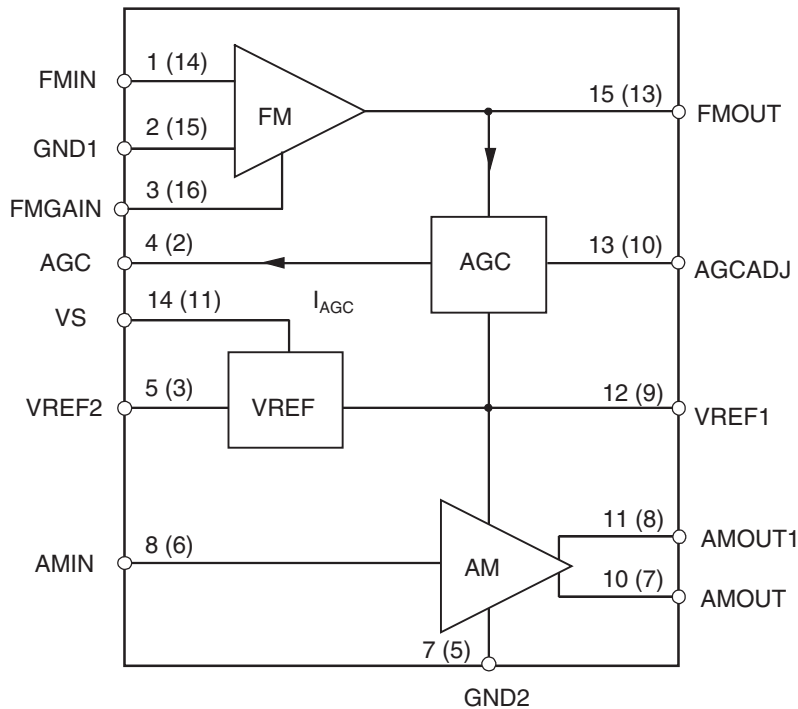


ATR4254

1. Description

The ATR4254 is an integrated low-noise AM/FM antenna impedance matching circuit in BiCMOS technology. The device is designed specifically for car applications and is suitable for windshield and roof antennas.

Figure 1-1. Block Diagram



() Pin numbers in brackets = QFN16 4 × 4 package

Rev. 4879A-AUDR-09/05



2. Pin Configuration

Figure 2-1. Pinning SO16

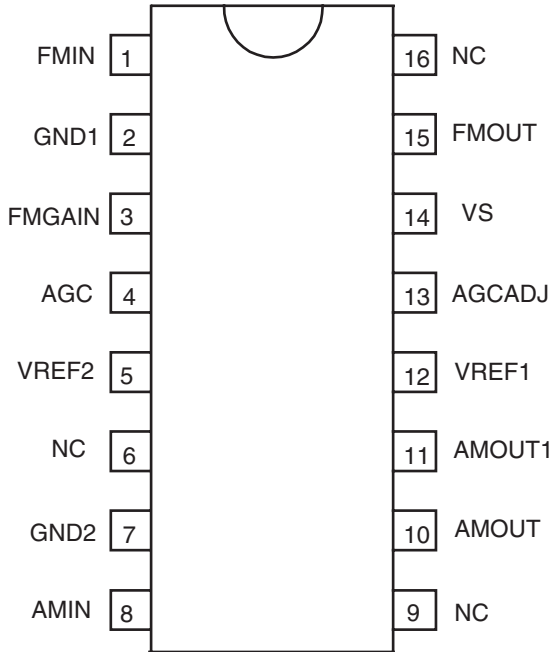


Figure 2-2. Pinning QFN16 4 × 4

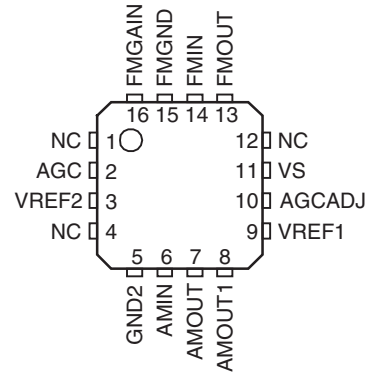


Table 2-1. Pin Description

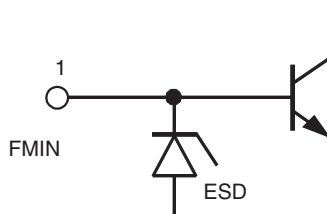
Pin SS016	Pin QFN16	Symbol	Function
1	14	FMIN	FM input
2	15	GND1	Ground for FM part
3	16	FMGAIN	FM gain adjustment
4	2	AGC	AGC output
5	3	VREF2	Reference voltage 2 output
6	1	NC	Not connected
7	5	GND2	Ground for AM part
8	6	AMIN	AM input
9	4	NC	Not connected
10	7	AMOUT	AM output
11	8	AMOUT1	AM output
12	9	VREF1	Reference voltage 1 output
13	10	AGCADJ	Adjustment FM wide-band AGC threshold
14	11	VS	Supply voltage
15	13	FMOUT	FM output
16	12	NC	Not connected

3. Pin Description

3.1 FMIN

The input of the FM amplifier, FMIN, is a bipolar transistor's base. A resistor or a coil is connected between FMIN and VREF2. If a coil is used, the noise performance is excellent.

Figure 3-1. Internal Circuit at Pin FMIN



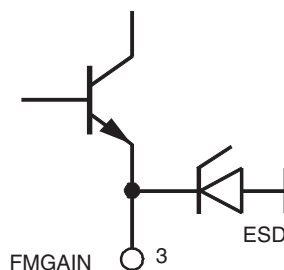
3.2 GND1

To avoid cross-talk between AM and FM signals, the circuit has two separate ground pins. GND1 is the ground for the FM part.

3.3 FMGAIN

The DC current of the FM amplifier transistor is adjusted by an external resistor which is connected between FMGAIN and GND1. To influence the AC gain of the amplifier, a resistor is connected in series to a capacitor between FMGAIN and GND1. The capacitor has to shorten frequencies of 100 MHz.

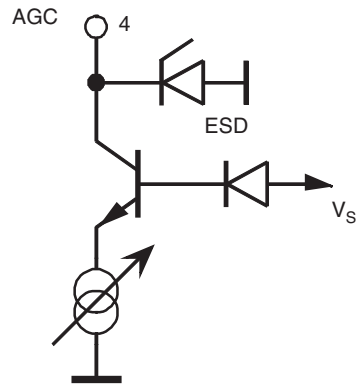
Figure 3-2. Internal Circuit at Pin FMGAIN



3.4 AGC

DC current flows into the AGC pin at high FM antenna input signals. This current has to be amplified via the current gain of an external PNP transistor that feeds a PIN diode. This diode dampens the antenna's input signal and protects the amplifier input against overload. The maximum current which flows into the AGC pin is approximately 1 mA. In low-end applications, the AGC function is not necessary and the external components can therefore be omitted.

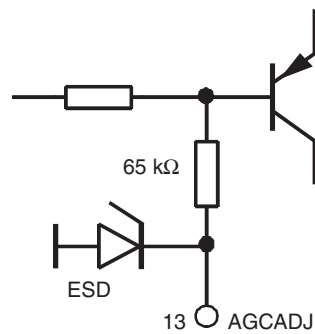
Figure 3-3. Internal Circuit at Pin AGC



3.5 AGCADJ

The threshold of the AGC can be adjusted by varying the DC current at pin AGCADJ. If pin AGCADJ is connected directly to GND1, the threshold is set to 96 dB μ V at the FM amplifier output. If a resistor is connected between AGCADJ and GND1, the threshold is shifted to higher values with increasing resistances. If AGCADJ is open, the threshold is set to 106 dB μ V.

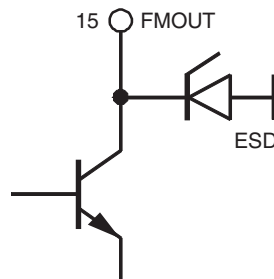
Figure 3-4. Internal Circuit at Pin AGCADJ



3.6 FMOUT

The FM amplifier output is an open collector of a bipolar RF transistor. It should be connected to V_S via a coil.

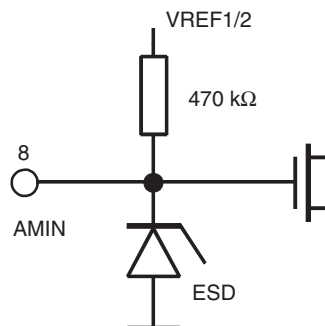
Figure 3-5. Internal Circuit at Pin FMOUT



3.7 AMIN

The AM input has an internal bias voltage. The DC voltage at this pin is $V_{Ref1/2}$. The input resistance is about 470 k Ω . The input capacitance is less than 10 pF.

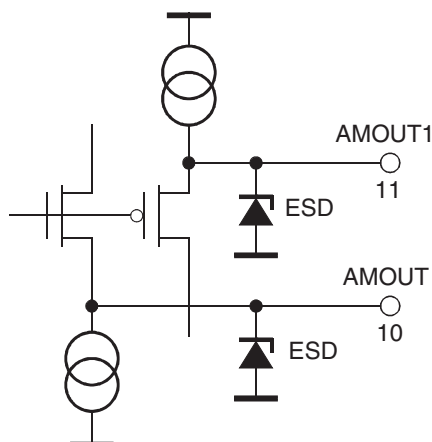
Figure 3-6. Internal Circuit at Pin AMIN



3.8 AMOUT, AMOUT1

The buffered AM amplifier consists of a complementary pair of CMOS source followers. The transistor gates are connected to AMIN. The pin AMOUT is the NMOS transistor's source, pin AMOUT1 is the PMOS transistor's source. Due to the two different DC levels of these pins, they have to be connected together via an external capacitor of about 100 nF. This technique can achieve an excellent dynamic range.

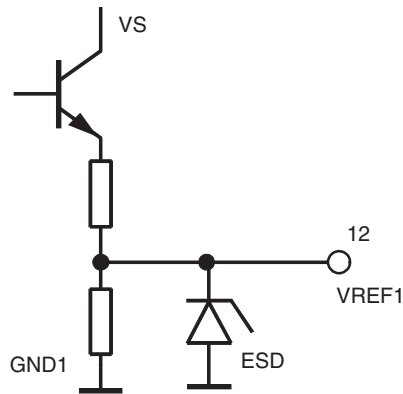
Figure 3-7. Internal Circuit at Pins AMOUT1 and AMOUT



3.9 VREF1

VREF1 is the stabilized voltage for the AM amplifier and the AGC block. To achieve excellent noise performance at LW frequencies, it is recommended that this pin be connected to ground via an external capacitor of about 1 μ F.

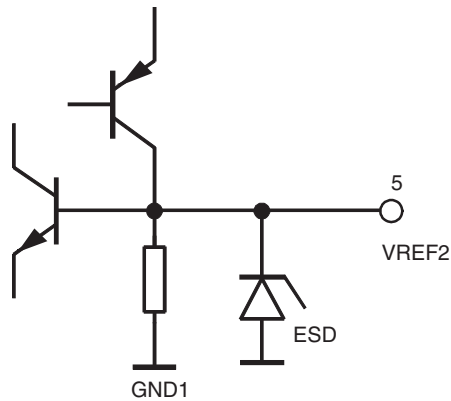
Figure 3-8. Internal Circuit at Pin VREF1



3.10 VREF2

For the DC biasing of the FM amplifier, a second voltage reference circuit is integrated. Since the collector current is temperature independent, the output voltage has a negative temperature coefficient of about -1 mV/K. To stabilize this voltage, an external capacitor to ground of a few nF is recommended.

Figure 3-9. Internal Circuit at Pin VREF2



3.11 GND2

GND2 is the ground for the AM amplifier.

4. Functional Description

The ATR4254 is an integrated AM/FM antenna impedance matching circuit. It compensates cable losses between the antenna (for example, windshield, roof or bumper antennas) and the car radio, which is usually placed far away from the antenna.

The FM amplifier provides excellent noise performance. External components are used to adjust the gain and the input-output matching impedance. Therefore, it is possible to adjust the amplifier to various cable impedances (usually 50Ω, 75Ω or 150Ω). To protect the amplifier against input overload, an Automatic Gain Control (AGC) is included on the chip. The AGC observes the AC voltage at the FM amplifier output, rectifies this signal, and delivers DC current to dampen the input antenna signal via an external PIN diode. The threshold for the AGC is adjustable. Simple and temperature-compensated biasing is possible due to the integrated voltage reference V_{Ref2} .

The AM part consists of a buffer amplifier. The voltage gain of this stage is approximately one. The input resistance is 470 kΩ, the input capacitance less than 10 pF. The output resistance is 125Ω. An excellent dynamic range is achieved due to the complementary CMOS source follower stage.

5. Absolute Maximum Ratings

Stresses beyond those listed under “Absolute Maximum Ratings” may cause permanent damage to the device. This is a stress rating only and functional operation of the device at these or any other conditions beyond those indicated in the operational sections of this specification is not implied. Exposure to absolute maximum rating conditions for extended periods may affect device reliability.

Reference point is ground (pins 2 and 7)

Parameters	Symbol	Value	Unit
Supply voltage	V_S	8.8	V
Power dissipation, P_{tot} at $T_{amb} = 85^\circ\text{C}$	P_{tot}	460	mW
Junction temperature	T_j	150	°C
Ambient temperature	T_{amb}	-40 to +85	°C
Storage temperature	T_{stg}	-50 to +150	°C
Electrostatic handling (HBM at ESD S.5.1)	$\pm V_{ESD}$	± 1000	V

6. Thermal Resistance

Parameters	Symbol	Value	Unit
Junction ambient	R_{thJA}	140	K/W

7. Electrical Characteristics

$V_S = 8V$, $T_{amb} = 25^\circ C$, unless otherwise specified (see Figure 7-1 on page 9).

Parameters	Test Conditions	Pin	Symbol	Min.	Typ.	Max.	Unit
Supply voltage		14	V_S	7.2	8	8.8	V
Supply currents		14	I_S	3.5	4.8	5.6	mA
Reference voltage 1 output ($I_{12} = 0$)		12	V_{Ref1}	5.1	5.4	5.7	V
Reference voltage 2 output ($I_5 = 0$)		5	V_{Ref2}	2.3	2.6	2.8	V
Temperature dependence of VREF2		5	$V_{Ref2}/\Delta T$		-1		mV/K
AM Amplifier							
Input resistance		8	R_{AMIN}		470		k Ω
Input capacitance		8	C_{AMIN}			10	pF
Output resistance		10	R_{OUT}		125		Ω
Voltage gain		8, 10	a		0.85		
Output noise voltage (rms value)	S1 switched to 2 B = 6 kHz 150 kHz to 300 kHz 500 kHz to 6.5 kHz	10	V_{N1} V_{N2}		-2 -6		dB μ V dB μ V
2nd harmonic	S2 switched to 1 $f_{AMIN} = 500$ kHz Output voltage = 110 dB μ V	10			-65		dBc
FM Amplifier							
Supply current limit	$I_{AGC}, I_{AGCADJ} = 0A$	15	I_{15}		33	35	mA
Input resistance	f = 100 MHz	1	R_{FMIN}		50		Ω
Output resistance	f = 100 MHz	15	R_{FMOUT}		50		Ω
Power gain	f = 100 MHz	1, 15	G		5		dB
Output noise voltage	f = 100 MHz B = 120 kHz	15	V_N		0		dB μ V
3rd-order output intercept	f = 100 MHz	15			132		dB μ V
AGC							
AGC input voltage threshold	f = 100 MHz S2 switched to 1; AGC threshold DC current is 10 μ A at pin 4	15	V_{th1}		96		dB μ V
AGC input voltage threshold	f = 100 MHz, S2 switched to 2; AGC threshold DC current is 10 μ A at pin 4	15	V_{th2}		106		dB μ V
AGC output current	AGC active		I_{AGC}			1.2	mA

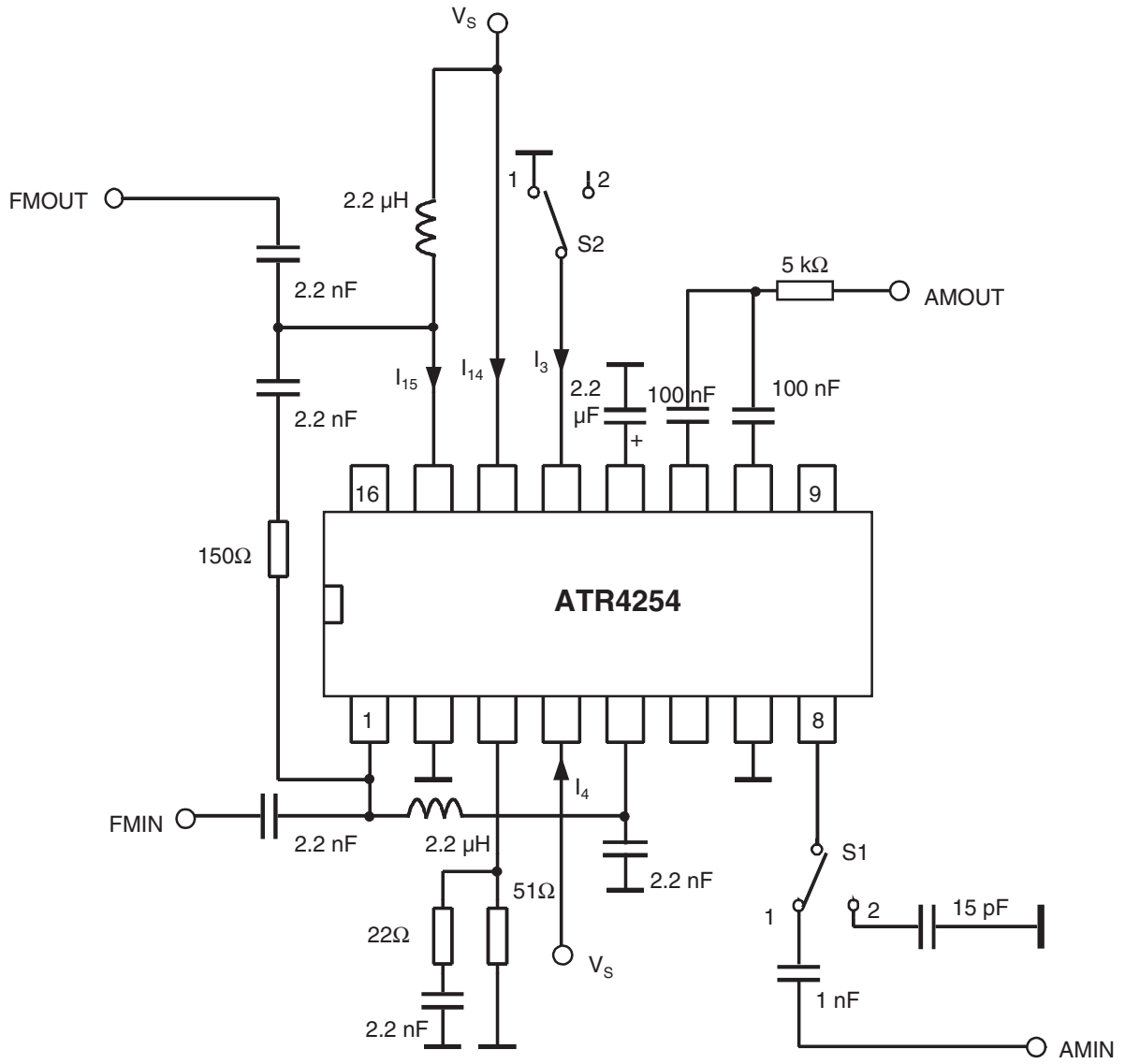
Figure 7-1. Test Circuit

Figure 7-2. FM Intermodulation Distortion

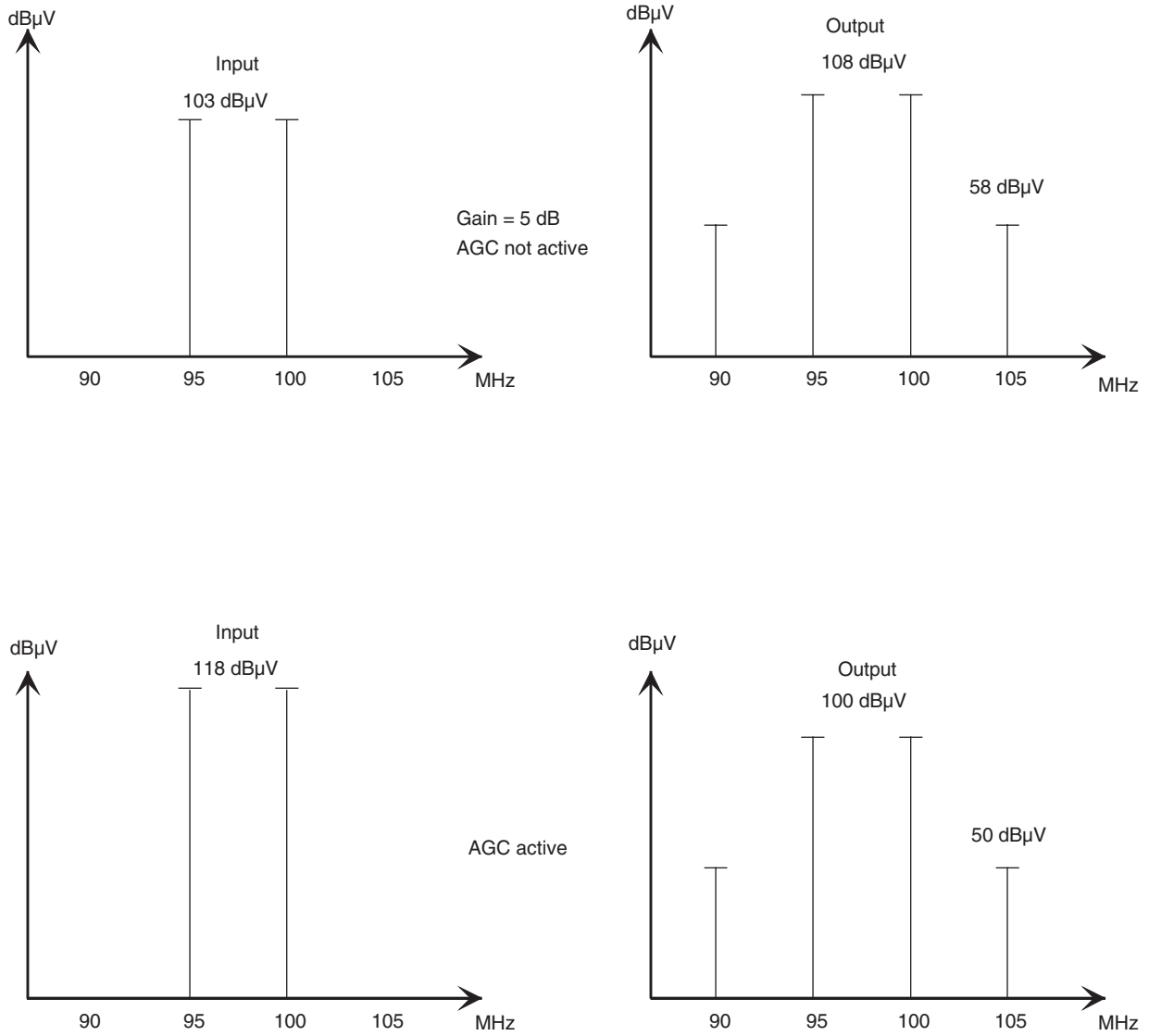


Figure 7-3. Test Circuit for AM Large Signal Behavior

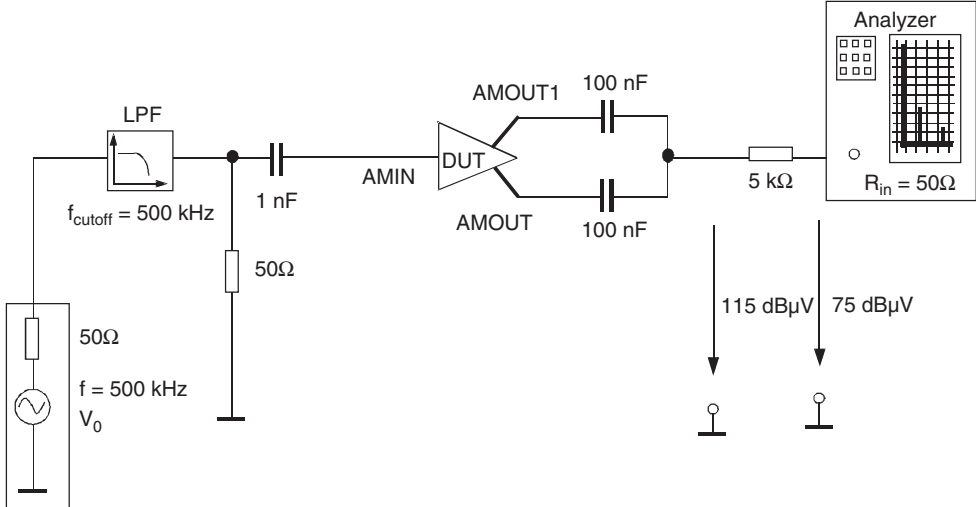


Figure 7-4. AM Harmonic Distortion

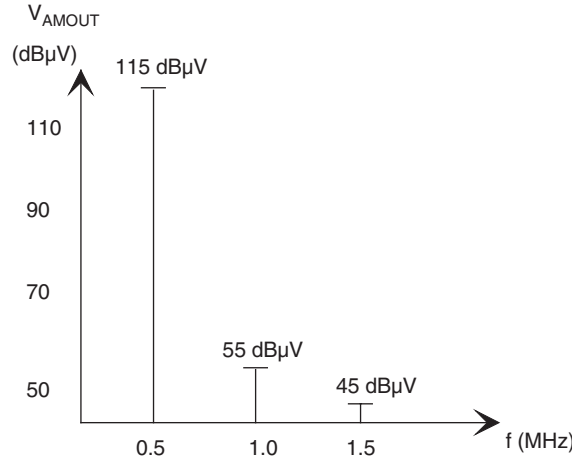
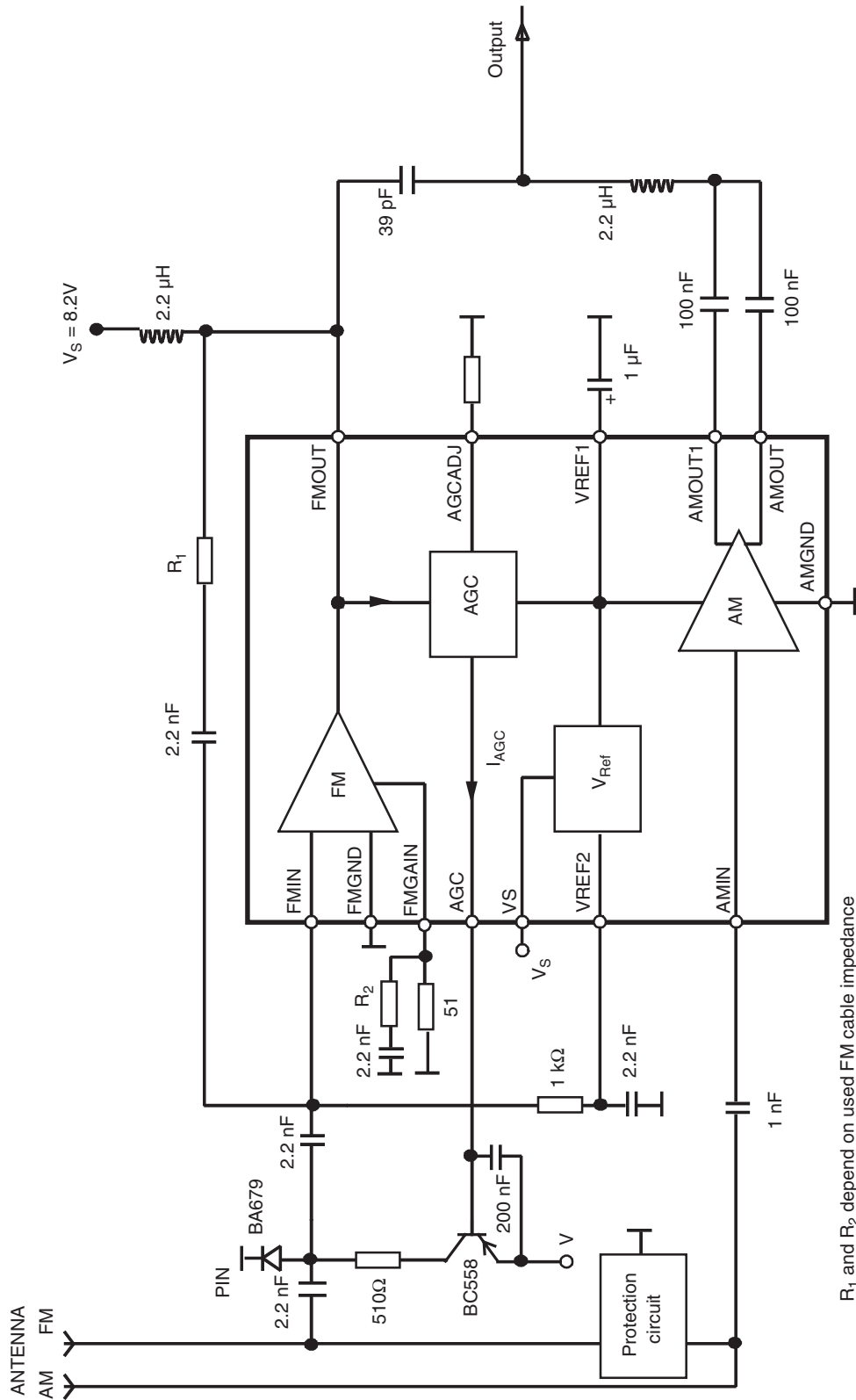


Figure 7-5. Application Circuit



R_1 and R_2 depend on used FM cable impedance

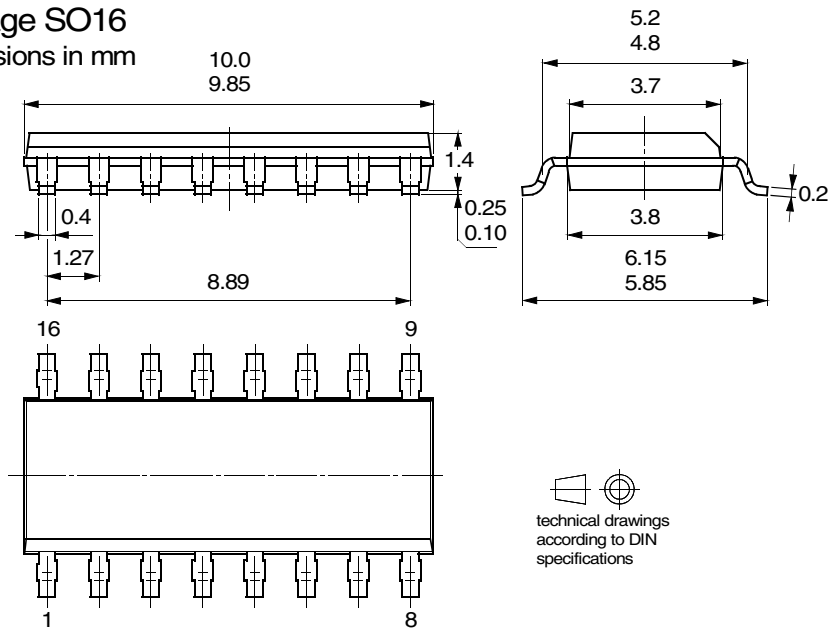
FM cable impedance	R_1 (Ω)	R_2 (Ω)
50	150	22
75	270	33
100	390	51
125	470	86
150	620	160

8. Ordering Information

Extended Type Number	Package	Remarks
ATR4254-TBJY	SO16	–
ATR4254-TBQY	SO16	Taping corresponding to ICE-286-3
ATR4254-PEPY	QFN16	–
ATR4254-PEQY	QFN16	Taping corresponding to ICE-286-3

9. Package Information

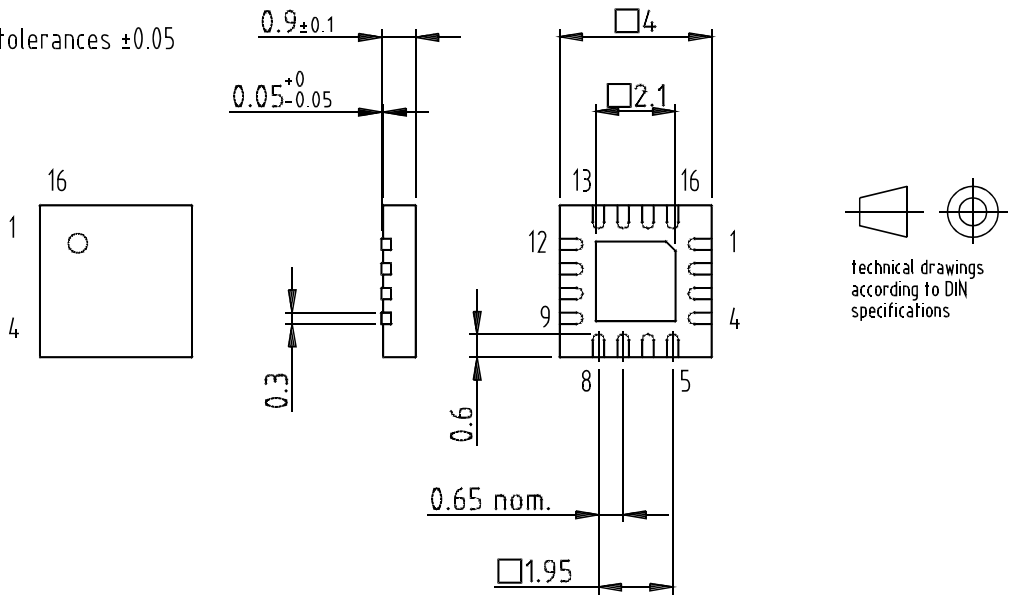
Package SO16
Dimensions in mm



technical drawings according to DIN specifications

Package: QFN 16 - 4x4
 Exposed pad 2.1x2.1
 (acc. JEDEC OUTLINE No. MO-220)
 Dimensions in mm

Not indicated tolerances ± 0.05



technical drawings according to DIN specifications

Drawing-No.: 6.543-5090.01-4
 Issue: 2; 24.01.03



Atmel Corporation

2325 Orchard Parkway
San Jose, CA 95131, USA
Tel: 1(408) 441-0311
Fax: 1(408) 487-2600

Regional Headquarters

Europe

Atmel Sarl
Route des Arsenalux 41
Case Postale 80
CH-1705 Fribourg
Switzerland
Tel: (41) 26-426-5555
Fax: (41) 26-426-5500

Asia

Room 1219
Chinachem Golden Plaza
77 Mody Road Tsimshatsui
East Kowloon
Hong Kong
Tel: (852) 2721-9778
Fax: (852) 2722-1369

Japan

9F, Tonetsu Shinkawa Bldg.
1-24-8 Shinkawa
Chuo-ku, Tokyo 104-0033
Japan
Tel: (81) 3-3523-3551
Fax: (81) 3-3523-7581

Atmel Operations

Memory

2325 Orchard Parkway
San Jose, CA 95131, USA
Tel: 1(408) 441-0311
Fax: 1(408) 436-4314

Microcontrollers

2325 Orchard Parkway
San Jose, CA 95131, USA
Tel: 1(408) 441-0311
Fax: 1(408) 436-4314

La Chantrerie
BP 70602
44306 Nantes Cedex 3, France
Tel: (33) 2-40-18-18-18
Fax: (33) 2-40-18-19-60

ASIC/ASSP/Smart Cards

Zone Industrielle
13106 Rousset Cedex, France
Tel: (33) 4-42-53-60-00
Fax: (33) 4-42-53-60-01

1150 East Cheyenne Mtn. Blvd.
Colorado Springs, CO 80906, USA
Tel: 1(719) 576-3300
Fax: 1(719) 540-1759

Scottish Enterprise Technology Park
Maxwell Building
East Kilbride G75 0QR, Scotland
Tel: (44) 1355-803-000
Fax: (44) 1355-242-743

RF/Automotive

Theresienstrasse 2
Postfach 3535
74025 Heilbronn, Germany
Tel: (49) 71-31-67-0
Fax: (49) 71-31-67-2340

1150 East Cheyenne Mtn. Blvd.
Colorado Springs, CO 80906, USA
Tel: 1(719) 576-3300
Fax: 1(719) 540-1759

Biometrics/Imaging/Hi-Rel MPU/ High Speed Converters/RF Datacom

Avenue de Rochepleine
BP 123
38521 Saint-Egreve Cedex, France
Tel: (33) 4-76-58-30-00
Fax: (33) 4-76-58-34-80

Literature Requests

www.atmel.com/literature

Disclaimer: The information in this document is provided in connection with Atmel products. No license, express or implied, by estoppel or otherwise, to any intellectual property right is granted by this document or in connection with the sale of Atmel products. **EXCEPT AS SET FORTH IN ATMEL'S TERMS AND CONDITIONS OF SALE LOCATED ON ATMEL'S WEB SITE, ATMEL ASSUMES NO LIABILITY WHATSOEVER AND DISCLAIMS ANY EXPRESS, IMPLIED OR STATUTORY WARRANTY RELATING TO ITS PRODUCTS INCLUDING, BUT NOT LIMITED TO, THE IMPLIED WARRANTY OF MERCHANTABILITY, FITNESS FOR A PARTICULAR PURPOSE, OR NON-INFRINGEMENT. IN NO EVENT SHALL ATMEL BE LIABLE FOR ANY DIRECT, INDIRECT, CONSEQUENTIAL, PUNITIVE, SPECIAL OR INCIDENTAL DAMAGES (INCLUDING, WITHOUT LIMITATION, DAMAGES FOR LOSS OF PROFITS, BUSINESS INTERRUPTION, OR LOSS OF INFORMATION) ARISING OUT OF THE USE OR INABILITY TO USE THIS DOCUMENT, EVEN IF ATMEL HAS BEEN ADVISED OF THE POSSIBILITY OF SUCH DAMAGES.** Atmel makes no representations or warranties with respect to the accuracy or completeness of the contents of this document and reserves the right to make changes to specifications and product descriptions at any time without notice. Atmel does not make any commitment to update the information contained herein. Unless specifically provided otherwise, Atmel products are not suitable for, and shall not be used in, automotive applications. Atmel's products are not intended, authorized, or warranted for use as components in applications intended to support or sustain life.

© Atmel Corporation 2005. All rights reserved. Atmel®, logo and combinations thereof, Everywhere You Are® and others, are registered trademarks or trademarks of Atmel Corporation or its subsidiaries. Other terms and product names may be trademarks of others.



Printed on recycled paper.

4879A-AUDR-09/05