

Features

- High Performance, Low Power AVR[®]32 32-Bit Microcontroller
 - 210 DMIPS throughput at 150 MHz
 - 16 KB instruction cache and 16 KB data caches
 - Memory Management Unit enabling use of operating systems
 - Single-cycle RISC instruction set including SIMD and DSP instructions
 - Java Hardware Acceleration
- Multimedia Co-Processor
 - Vector Multiplication Unit for video acceleration through color-space conversion (YUV-<->RGB), image scaling and filtering, quarter pixel motion compensation
- Multi-hierarchy bus system
 - High-performance data transfers on separate buses for increased performance
- Data Memories
 - 32KBytes SRAM
- External Memory Interface
 - SDRAM, DataFlash[™], SRAM, Multi Media Card (MMC), Secure Digital (SD), Compact Flash, Smart Media, NAND Flash
- Direct Memory Access Controller
 - External Memory access without CPU intervention
- Interrupt Controller
 - Individually maskable Interrupts
 - Each interrupt request has a programmable priority and autovector address
- System Functions
 - Power and Clock Manager
 - Crystal Oscillator with Phase-Lock-Loop (PLL)
 - Watchdog Timer
 - Real-time Clock
- 6 Multifunction timer/counters
 - Three external clock inputs, I/O pins, PWM, capture and various counting capabilities
- 4 Universal Synchronous/Asynchronous Receiver/Transmitters (USART)
 - 115.2 kbps IrDA Modulation and Demodulation
 - Hardware and software handshaking
- 3 Synchronous Serial Protocol controllers
 - Supports I2S, SPI and generic frame-based protocols
- Two-Wire Interface
 - Sequential Read/Write Operations, Philips' I2C[®] compatible
- Image Sensor Interface
 - 12-bit Data Interface for CMOS cameras
- Universal Serial Bus (USB) 2.0 High Speed (480 Mbps) Device
 - On-chip Transceivers with physical interface
- 16-bit stereo audio DAC
 - Sample rates up to 50 kHz
- On-Chip Debug System
 - Nexus Class 3
 - Full speed, non-intrusive data and program trace
 - Runtime control and JTAG interface
- Package/Pins
 - AT32AP7001: 208-pin QFP/ 90 GPIO pins
- Power supplies
 - 1.65V to 1.95V VDDCORE
 - 3.0V to 3.6V VDDIO



AVR[®]32 32-bit Microcontroller

AT32AP7001

Preliminary



1. Part Description

The AT32AP7001 is a complete System-on-chip application processor with an AVR32 RISC processor achieving 210 DMIPS running at 150 MHz. AVR32 is a high-performance 32-bit RISC microprocessor core, designed for cost-sensitive embedded applications, with particular emphasis on low power consumption, high code density and high application performance.

AT32AP7001 implements a Memory Management Unit (MMU) and a flexible interrupt controller supporting modern operating systems and real-time operating systems. The processor also includes a rich set of DSP and SIMD instructions, specially designed for multimedia and telecom applications.

AT32AP7001 incorporates SRAM memories on-chip for fast and secure access. For applications requiring additional memory, external 16-bit SRAM is accessible. Additionally, an SDRAM controller provides off-chip volatile memory access as well as controllers for all industry standard off-chip non-volatile memories, like Compact Flash, Multi Media Card (MMC), Secure Digital (SD)-card, SmartCard, NAND Flash and Atmel DataFlash™.

The Direct Memory Access controller for all the serial peripherals enables data transfer between memories without processor intervention. This reduces the processor overhead when transferring continuous and large data streams between modules in the MCU.

The Timer/Counters includes three identical 16-bit timer/counter channels. Each channel can be independently programmed to perform a wide range of functions including frequency measurement, event counting, interval measurement, pulse generation, delay timing and pulse width modulation.

A pixel co-processor provides color space conversions for images and video, in addition to a wide variety of hardware filter support

Synchronous Serial Controllers provide easy access to serial communication protocols, audio standards like AC'97, I2S, I2C© and various SPI modes. The modules support frame-based protocols, like VoIP SIP protocols.

The Java hardware acceleration implementation in AVR32 allows for a very high-speed Java byte-code execution. AVR32 implements Java instructions in hardware, reusing the existing RISC data path, which allows for a near-zero hardware overhead and cost with a very high performance.

The Image Sensor Interface supports cameras with up to 12-bit data buses and connects directly to the LCD interface through a separate bus.

PS2 connectivity is provided for standard input devices like mice and keyboards.

AT32AP7001 integrates a class 3 Nexus 2.0 On-Chip Debug (OCD) System, with non-intrusive real-time trace, full-speed read/write memory access in addition to basic runtime control.

The C-compiler is closely linked to the architecture and is able to utilize code optimization features, both for size and speed.

2. Signals Description

The following table gives details on the signal name classified by peripheral. The pinout multiplexing of these signals is given in the Peripheral Muxing table in the Peripherals chapter.

Table 2-1. Signal Description List

Signal Name	Function	Type	Active Level	Comments
Power				
AVDDPLL	PLL Power Supply	Power		1.65 to 1.95 V
AVDDUSB	USB Power Supply	Power		1.65 to 1.95 V
AVDDOSC	Oscillator Power Supply	Power		1.65 to 1.95 V
VDDCORE	Core Power Supply	Power		1.65 to 1.95 V
VDDIO	I/O Power Supply	Power		3.0 to 3.6V
AGNDPLL	PLL Ground	Ground		
AGNDUSB	USB Ground	Ground		
AGNDOSC	Oscillator Ground	Ground		
GND	Ground	Ground		
Clocks, Oscillators, and PLL's				
XIN0, XIN1, XIN32	Crystal 0, 1, 32 Input	Analog		
XOUT0, XOUT1, XOUT32	Crystal 0, 1, 32 Output	Analog		
PLL0, PLL1	PLL 0,1 Filter Pin	Analog		
JTAG				
TCK	Test Clock	Input		
TDI	Test Data In	Input		
TDO	Test Data Out	Output		
TMS	Test Mode Select	Input		
TRST_N	Test Reset	Input	Low	
Auxiliary Port - AUX				
MCKO	Trace Data Output Clock	Output		
MDO0 - MDO5	Trace Data Output	Output		
MSEO0 - MSEO1	Trace Frame Control	Output		
EVTI_N	Event In	Input	Low	

Table 2-1. Signal Description List

Signal Name	Function	Type	Active Level	Comments
EVTO_N	Event Out	Output	Low	
Power Manager - PM				
GCLK0 - GCLK4	Generic Clock Pins	Output		
OSCEN_N	Oscillator Enable	Input	Low	
RESET_N	Reset Pin	Input	Low	
WAKE_N	Wake Pin	Input	Low	
External Interrupt Module - EIM				
EXTINT0 - EXTINT3	External Interrupt Pins	Input		
NMI_N	Non-Maskable Interrupt Pin	Input	Low	
AC97 Controller - AC97C				
SCLK	AC97 Clock Signal	Input		
SDI	AC97 Receive Signal	Output		
SDO	AC97 Transmit Signal	Output		
SYNC	AC97 Frame Synchronization Signal	Input		
DAC - DAC				
DATA0 - DATA1	D/A Data Out	Output		
DATAN0 - DATAN1	D/A Inverted Data Out	Output		
External Bus Interface - EBI				
ADDR0 - ADDR25	Address Bus	Output		
CAS	Column Signal	Output	Low	
CFCE1	Compact Flash 1 Chip Enable	Output	Low	
CFCE2	Compact Flash 2 Chip Enable	Output	Low	
CFRNW	Compact Flash Read Not Write	Output		
DATA0 - DATA31	Data Bus	I/O		
NANDOE	NAND Flash Output Enable	Output	Low	
NANDWE	NAND Flash Write Enable	Output	Low	
NCS0 - NCS5	Chip Select	Output	Low	
NRD	Read Signal	Output	Low	

Table 2-1. Signal Description List

Signal Name	Function	Type	Active Level	Comments
NWAIT	External Wait Signal	Input	Low	
NWE0	Write Enable 0	Output	Low	
NWE1	Write Enable 1	Output	Low	
NWE3	Write Enable 3	Output	Low	
RAS	Row Signal	Output	Low	
SDA10	SDRAM Address 10 Line	Output		
SDCK	SDRAM Clock	Output		
SDCKE	SDRAM Clock Enable	Output		
SDCS	SDRAM Chip Select	Output	Low	
SDWE	SDRAM Write Enable	Output	Low	
Image Sensor Interface - ISI				
DATA0 - DATA11	Image Sensor Data	Input		
HSYNC	Horizontal Synchronization	Input		
PCLK	Image Sensor Data Clock	Input		
VSYSN	Vertical Synchronization	Input		
Multimedia Card Interface - MMCI				
CLK	Multimedia Card Clock	Output		
CMD0 - CMD1	Multimedia Card Command	I/O		
DATA0 - DATA7	Multimedia Card Data	I/O		
Parallel Input/Output 2 - PIOA, PIOB, PIOC, PIOD, PIOE				
PA0 - PA31	Parallel I/O Controller PIOA	I/O		
PB0 - PB30	Parallel I/O Controller PIOB	I/O		
PC0 - PC31	Parallel I/O Controller PIOC	I/O		
PD0 - PD17	Parallel I/O Controller PIOD	I/O		
PE0 - PE26	Parallel I/O Controller PIOE	I/O		
PS2 Interface - PSIF				
CLOCK0 - CLOCK1	PS2 Clock	Input		
DATA0 - DATA1	PS2 Data	I/O		

Table 2-1. Signal Description List

Signal Name	Function	Type	Active Level	Comments
Serial Peripheral Interface - SPI0, SPI1				
MISO	Master In Slave Out	I/O		
MOSI	Master Out Slave In	I/O		
NPCS0 - NPCS3	SPI Peripheral Chip Select	I/O	Low	
SCK	Clock	Output		
Synchronous Serial Controller - SSC0, SSC1, SSC2				
RX_CLOCK	SSC Receive Clock	I/O		
RX_DATA	SSC Receive Data	Input		
RX_FRAME_SYNC	SSC Receive Frame Sync	I/O		
TX_CLOCK	SSC Transmit Clock	I/O		
TX_DATA	SSC Transmit Data	Output		
TX_FRAME_SYNC	SSC Transmit Frame Sync	I/O		
DMA Controller - DMAC				
DMARQ0 - DMARQ3	DMA Requests	Input		
Timer/Counter - TIMER0, TIMER1				
A0	Channel 0 Line A	I/O		
A1	Channel 1 Line A	I/O		
A2	Channel 2 Line A	I/O		
B0	Channel 0 Line B	I/O		
B1	Channel 1 Line B	I/O		
B2	Channel 2 Line B	I/O		
CLK0	Channel 0 External Clock Input	Input		
CLK1	Channel 1 External Clock Input	Input		
CLK2	Channel 2 External Clock Input	Input		
Two-wire Interface - TWI				
SCL	Serial Clock	I/O		
SDA	Serial Data	I/O		
Universal Synchronous Asynchronous Receiver Transmitter - USART0, USART1, USART2, USART3				

Table 2-1. Signal Description List

Signal Name	Function	Type	Active Level	Comments
CLK	Clock	I/O		
CTS	Clear To Send	Input		
RTS	Request To Send	Output		
RXD	Receive Data	Input		
TXD	Transmit Data	Output		
Pulse Width Modulator - PWM				
PWM0 - PWM3	PWM Output Pins	Output		
Universal Serial Bus Device - USB				
DDM	USB Device Port Data -	Analog		
DDP	USB Device Port Data +	Analog		
VBG	USB bandgap	Analog		Connected to a 6810 Ohm \pm 0.5% resistor to ground and a 10 pF capacitor to ground.

3. Power Considerations

3.1 Power Supplies

The AT32AP7001 has several types of power supply pins:

- **VDDCORE pins:** Power the core, memories, and peripherals. Voltage is 1.8V nominal.
- **VDDIO pins:** Power I/O lines. Voltage is 3.3V nominal.
- **VDDPLL pin:** Powers the PLL. Voltage is 1.8V nominal.
- **VDDUSB pin:** Powers the USB. Voltage is 1.8V nominal.
- **VDDOSC pin:** Powers the oscillators. Voltage is 1.8V nominal.

The ground pins GND are common to VDDCORE and VDDIO. The ground pin for VDDPLL is GNDPLL, and the GND pin for VDDOSC is GNDOSC.

See "Electrical Characteristics" on page 770 for power consumption on the various supply pins.

3.2 Power Supply Connections

Special considerations should be made when connecting the power and ground pins on a PCB. Figure 3-1 shows how this should be done.

Figure 3-1. Connecting analog power supplies

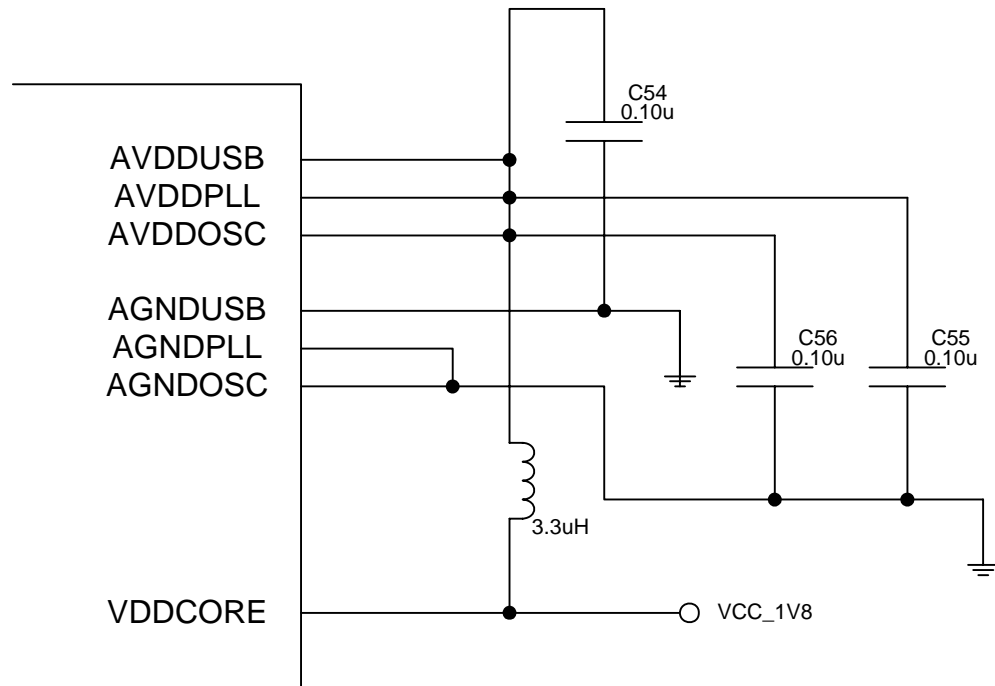

4. Package and Pinout

4.1 AVR32AP7001

Figure 4-1. 208 QFP Pinout.

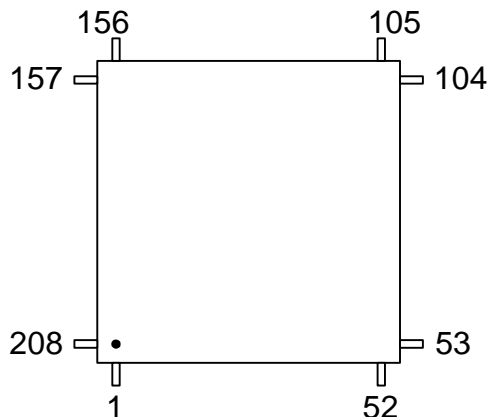

Table 4-1. QFP-208 Package Pinout

1	GND	53	GND	105	GND	157	GND
2	PE17	54	PA23	106	PX13	158	PB10
3	PE18	55	PA24	107	PX14	159	PB11
4	PX47	56	XIN1	108	PX15	160	PB12
5	PX48	57	XOUT1	109	PX16	161	PB13
6	PX49	58	AVDDUSB	110	PX17	162	PB14
7	PX50	59	AGNDUSB	111	PX34	163	PB15
8	PX51	60	VDDIO	112	PX35	164	PB16
9	VDDIO	61	FSDM	113	PX36	165	PB17
10	PX32	62	FSDP	114	PX37	166	PB18
11	PX33	63	GND	115	PX38	167	PB19
12	PX00	64	GND	116	PX18	168	PB20
13	PX01	65	HSDM	117	PX19	169	PB21
14	PX02	66	HSDP	118	PX20	170	PB22
15	PX03	67	VDDCORE	119	PX21	171	PB23
16	PX04	68	GND	120	PX22	172	VDDCORE
17	PX05	69	GND	121	PX23	173	GND
18	VDDCORE	70	VBG	122	PX24	174	GND
19	GND	71	VDDIO	123	PX25	175	PA06
20	TDO	72	PA25	124	PX26	176	PA07
21	TCK	73	PA26	125	VDDIO	177	VDDIO

Table 4-1. QFP-208 Package Pinout (Continued)

22	TMS		74	PA27		126	PX27		178	VDDIO
23	TDI		75	PA28		127	PX28		179	OSCEN_N
24	TRST_N		76	PA29		128	PX29		180	XIN32
25	EVTI_N		77	PA30		129	PX30		181	XOUT32
26	RESET_N		78	PA31		130	PX31		182	AGNDOSC
27	PA00		79	WAKE_N		131	VDDCORE		183	AVDDOSC
28	PA01		80	PB26		132	GND		184	PLL1
29	PA02		81	PB27		133	GND		185	XIN0
30	PA03		82	PB28		134	PE26		186	XOUT0
31	PA04		83	PX53		135	PX39		187	AGNDPLL
32	PA05		84	PX52		136	VDDCORE		188	AVDDPLL
33	PB24		85	PX41		137	GND		189	PLL0
34	PB25		86	GND		138	PX40		190	PE00
35	PA08		87	PE25		139	PX42		191	PE01
36	VDDIO		88	PE24		140	PX43		192	PE02
37	GND		89	PE23		141	PX44		193	PE03
38	PA09		90	PE22		142	PX45		194	PE04
39	PA10		91	PE21		143	PX46		195	PE05
40	PA11		92	PE20		144	PB00		196	PE06
41	PA12		93	PE19		145	PB01		197	PE07
42	PA13		94	PX06		146	PB02		198	PE08
43	PA14		95	PX07		147	PB03		199	PE09
44	PA15		96	PX08		148	PB04		200	PE10
45	PA16		97	PX09		149	PB05		201	PE11
46	PA17		98	PX10		150	PB06		202	PE12
47	PA18		99	PX11		151	PB07		203	PE13
48	PA19		100	PB29		152	PB08		204	PE14
49	PA20		101	PB30		153	PB09		205	PE15
50	PA21		102	PX12		154	PC16		206	PE16
51	PA22		103	PC00		155	PC17		207	No Connect
52	VDDIO		104	VDDIO		156	VDDIO		208	GND

5. Blockdiagram

Figure 5-1. Blockdiagram

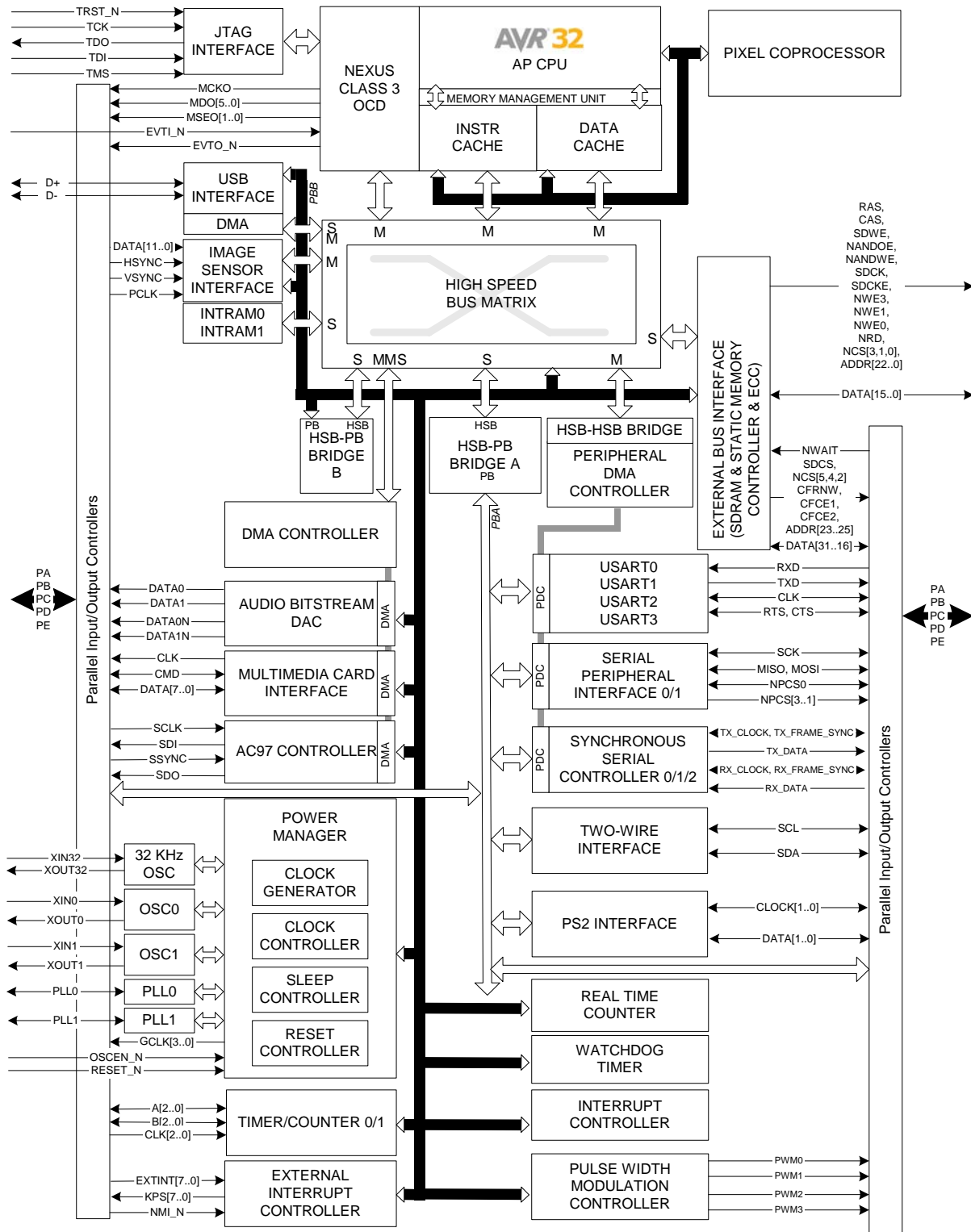

5.1 Processor and architecture

5.1.1 AVR32AP CPU

- 32-bit load/store AVR32B RISC architecture.
 - Up to 15 general-purpose 32-bit registers.
 - 32-bit Stack Pointer, Program Counter and Link Register reside in register file.
 - Fully orthogonal instruction set.
 - Privileged and unprivileged modes enabling efficient and secure Operating Systems.
 - Innovative instruction set together with variable instruction length ensuring industry leading code density.
 - DSP extension with saturating arithmetic, and a wide variety of multiply instructions.
 - SIMD extension for media applications.
- 7 stage pipeline allows one instruction per clock cycle for most instructions.
 - Java Hardware Acceleration.
 - Byte, half-word, word and double word memory access.
 - Unaligned memory access.
 - Shadowed interrupt context for INT3 and multiple interrupt priority levels.
 - Dynamic branch prediction and return address stack for fast change-of-flow.
 - Coprocessor interface.
- Full MMU allows for operating systems with memory protection.
- 16Kbyte Instruction and 16Kbyte data caches.
 - Virtually indexed, physically tagged.
 - 4-way associative.
 - Write-through or write-back.
- Nexus Class 3 On-Chip Debug system.
 - Low-cost NanoTrace supported.

5.1.2 Pixel Coprocessor (PiCo)

- Coprocessor coupled to the AVR32 CPU Core through the TCB Bus.
- Three parallel Vector Multiplication Units (VMU) where each unit can:
 - Multiply three pixel components with three coefficients.
 - Add the products from the multiplications together.
 - Accumulate the result or add an offset to the sum of the products.
- Can be used for accelerating:
 - Image Color Space Conversion.
 - Configurable Conversion Coefficients.
 - Supports packed and planar input and output formats.
 - Supports subsampled input color spaces (i.e 4:2:2, 4:2:0).
 - Image filtering/scaling.
 - Configurable Filter Coefficients.
 - Throughput of one sample per cycle for a 9-tap FIR filter.
 - Can use the built-in accumulator to extend the FIR filter to more than 9-taps.
 - Can be used for bilinear/bicubic interpolations.
 - MPEG-4/H.264 Quarter Pixel Motion Compensation.
- Flexible input Pixel Selector.
 - Can operate on numerous different image storage formats.
- Flexible Output Pixel Inserter.
 - Scales and saturates the results back to 8-bit pixel values.

- Supports packed and planar output formats.
- Configurable coefficients with flexible fixed-point representation.

5.1.3 Debug and Test system

- IEEE1149.1 compliant JTAG and boundary scan
- Direct memory access and programming capabilities through JTAG interface
- Extensive On-Chip Debug features in compliance with IEEE-ISTO 5001-2003 (Nexus 2.0) Class 3
- Auxiliary port for high-speed trace information
- Hardware support for 6 Program and 2 data breakpoints
- Unlimited number of software breakpoints supported
- Advanced Program, Data, Ownership, and Watchpoint trace supported

5.1.4 DMA controller

- 2 HSB Master Interfaces
- 3 Channels
- Software and Hardware Handshaking Interfaces
 - 11 Hardware Handshaking Interfaces
- Memory/Non-Memory Peripherals to Memory/Non-Memory Peripherals Transfer
- Single-block DMA Transfer
- Multi-block DMA Transfer
 - Linked Lists
 - Auto-Reloading
 - Contiguous Blocks
- DMA Controller is Always the Flow Controller
- Additional Features
 - Scatter and Gather Operations
 - Channel Locking
 - Bus Locking
 - FIFO Mode
 - Pseudo Fly-by Operation

5.1.5 Peripheral DMA Controller

- Transfers from/to peripheral to/from any memory space without intervention of the processor.
- Next Pointer Support, forbids strong real-time constraints on buffer management.
- Eighteen channels
 - Two for each USART
 - Two for each Serial Synchronous Controller
 - Two for each Serial Peripheral Interface

5.1.6 Bus system

- HSB bus matrix with 10 Masters and 8 Slaves handled
 - Handles Requests from the CPU Icache, CPU Dcache, HSB bridge, HISI, USB 2.0 Controller, DMA Controller 0, DMA Controller 1, and to internal SRAM 0, internal SRAM 1, PB A, PB B, EBI and, USB.

- Round-Robin Arbitration (three modes supported: no default master, last accessed default master, fixed default master)
- Burst Breaking with Slot Cycle Limit
- One Address Decoder Provided per Master
- 2 Peripheral buses allowing each bus to run on different bus speeds.
 - PB A intended to run on low clock speeds, with peripherals connected to the PDC.
 - PB B intended to run on higher clock speeds, with peripherals connected to the DMAC.
- HSB-HSB Bridge providing a low-speed HSB bus running at the same speed as PBA
 - Allows PDC transfers between a low-speed PB bus and a bus matrix of higher clock speeds

An overview of the bus system is given in [Figure 5-1 on page 11](#). All modules connected to the same bus use the same clock, but the clock to each module can be individually shut off by the Power Manager. The figure identifies the number of master and slave interfaces of each module connected to the HSB bus, and which DMA controller is connected to which peripheral.

6. I/O Line Considerations

6.1 JTAG pins

The TMS, TDI and TCK pins have pull-up resistors. TDO is an output, driven at up to VDDIO, and have no pull-up resistor. The TRST_N pin is used to initialize the embedded JTAG TAP Controller when asserted at a low level. It is a schmitt input and integrates permanent pull-up resistor to VDDIO, so that it can be left unconnected for normal operations.

6.2 WAKE_N pin

The WAKE_N pin is a schmitt trigger input integrating a permanent pull-up resistor to VDDIO.

6.3 RESET_N pin

The RESET_N pin is a schmitt input and integrates a permanent pull-up resistor to VDDIO. As the product integrates a power-on reset cell, the RESET_N pin can be left unconnected in case no reset from the system needs to be applied to the product.

6.4 EVTI_N pin

The EVTI_N pin is a schmitt input and integrates a non-programmable pull-up resistor to VDDIO.

6.5 TWI pins

When these pins are used for TWI, the pins are open-drain outputs with slew-rate limitation and inputs with inputs with spike-filtering. When used as GPIO-pins or used for other peripherals, the pins have the same characteristics as PIO pins.

6.6 PIO pins

All the I/O lines integrate a programmable pull-up resistor. Programming of this pull-up resistor is performed independently for each I/O line through the PIO Controllers. After reset, I/O lines default as inputs with pull-up resistors enabled, except when indicated otherwise in the column "Reset State" of the PIO Controller multiplexing tables.

7. AVR32 AP CPU

This chapter gives an overview of the AVR32 AP CPU. AVR32 AP is an implementation of the AVR32 architecture. A summary of the programming model, instruction set, caches and MMU is presented. For further details, see the *AVR32 Architecture Manual* and the *AVR32 AP Technical Reference Manual*.

7.1 AVR32 Architecture

AVR32 is a new, high-performance 32-bit RISC microprocessor architecture, designed for cost-sensitive embedded applications, with particular emphasis on low power consumption and high code density. In addition, the instruction set architecture has been tuned to allow a variety of microarchitectures, enabling the AVR32 to be implemented as low-, mid- or high-performance processors. AVR32 extends the AVR family into the world of 32- and 64-bit applications.

Through a quantitative approach, a large set of industry recognized benchmarks has been compiled and analyzed to achieve the best code density in its class. In addition to lowering the memory requirements, a compact code size also contributes to the core's low power characteristics. The processor supports byte and half-word data types without penalty in code size and performance.

Memory load and store operations are provided for byte, half-word, word and double word data with automatic sign- or zero extension of half-word and byte data.

In order to reduce code size to a minimum, some instructions have multiple addressing modes. As an example, instructions with immediates often have a compact format with a smaller immediate, and an extended format with a larger immediate. In this way, the compiler is able to use the format giving the smallest code size.

Another feature of the instruction set is that frequently used instructions, like add, have a compact format with two operands as well as an extended format with three operands. The larger format increases performance, allowing an addition and a data move in the same instruction in a single cycle. Load and store instructions have several different formats in order to reduce code size and speed up execution.

The register file is organized as sixteen 32-bit registers and includes the Program Counter, the Link Register, and the Stack Pointer. In addition, register R12 is designed to hold return values from function calls and is used implicitly by some instructions.

7.2 The AVR32 AP CPU

AVR32 AP targets high-performance applications, and provides an advanced OCD system, efficient data and instruction caches, and a full MMU. [Figure 7-1 on page 17](#) displays the contents of AVR32 AP.

Figure 7-1. Overview of the AVR32 AP CPU

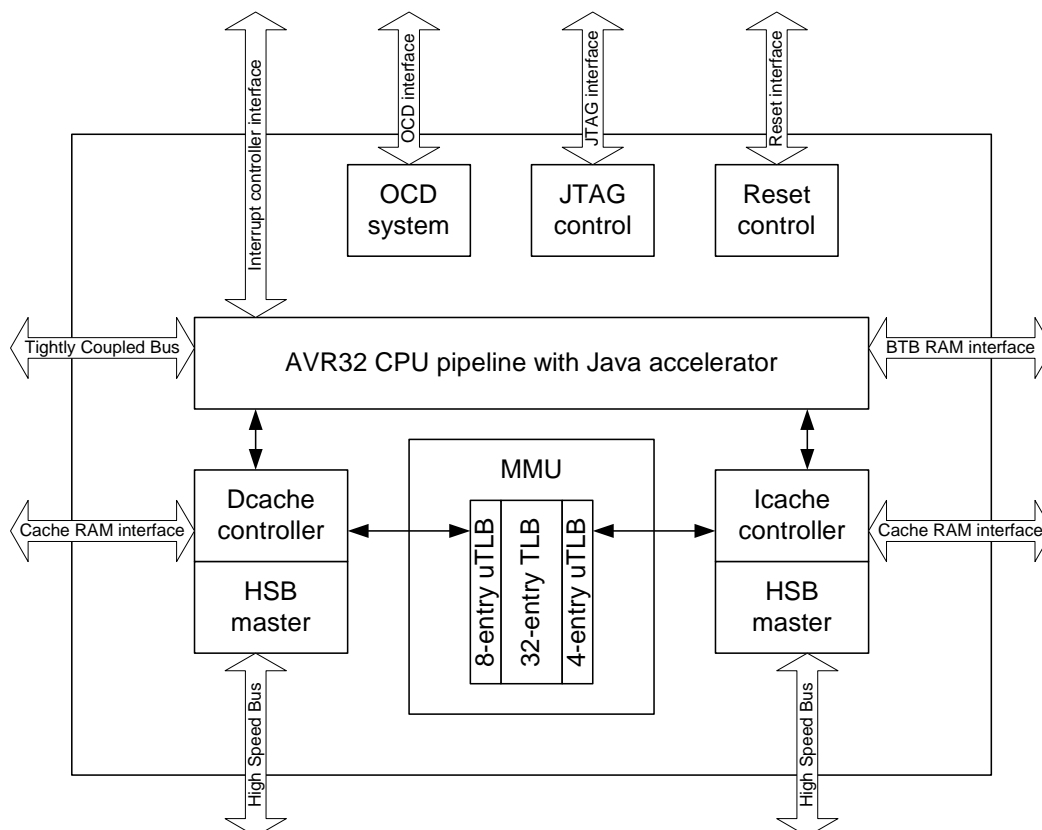

7.2.1 Pipeline Overview

AVR32 AP is a pipelined processor with seven pipeline stages. The pipeline has three subpipes, namely the Multiply pipe, the Execute pipe and the Data pipe. These pipelines may execute different instructions in parallel. Instructions are issued in order, but may complete out of order (OOO) since the subpipes may be stalled individually, and certain operations may use a subpipe for several clock cycles.

[Figure 7-2 on page 18](#) shows an overview of the AVR32 AP pipeline stages.

Figure 7-2. The AVR32 AP Pipeline

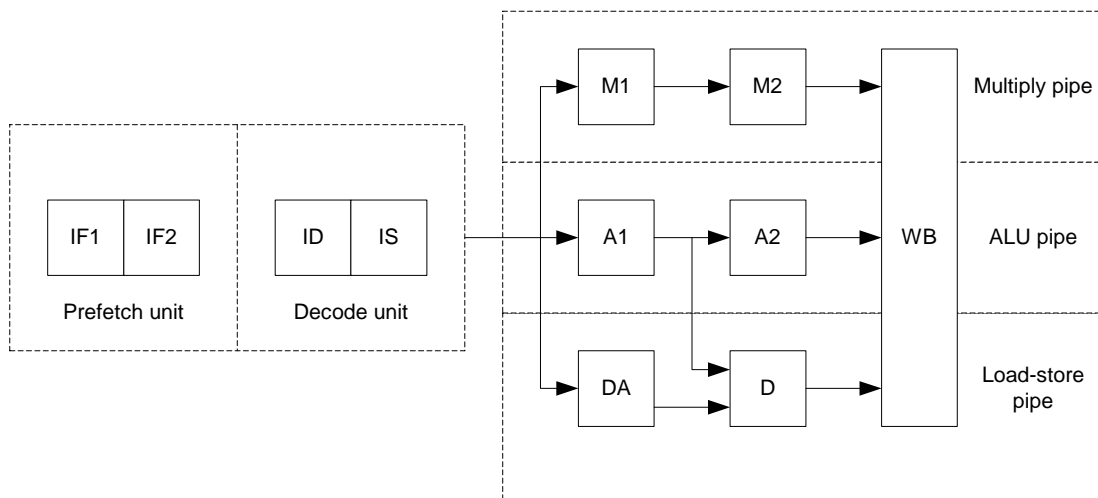

The following abbreviations are used in the figure:

- IF1, IF2 - Instruction Fetch stage 1 and 2
- ID - Instruction Decode
- IS - Instruction Issue
- A1, A2 - ALU stage 1 and 2
- M1, M2 - Multiply stage 1 and 2
- DA - Data Address calculation stage
- D - Data cache access
- WB - Writeback

7.2.2 AVR32B Microarchitecture Compliance

AVR32 AP implements an AVR32B microarchitecture. The AVR32B microarchitecture is targeted at applications where interrupt latency is important. The AVR32B therefore implements dedicated registers to hold the status register and return address for interrupts, exceptions and supervisor calls. This information does not need to be written to the stack, and latency is therefore reduced. Additionally, AVR32B allows hardware shadowing of the registers in the register file.

The *scall*, *rete* and *rets* instructions use the dedicated return status registers and return address registers in their operation. No stack accesses are performed by these instructions.

7.2.3 Java Support

AVR32 AP provides Java hardware acceleration in the form of a Java Virtual Machine hardware implementation. Refer to the *AVR32 Java Technical Reference Manual* for details.

7.2.4 Memory management

AVR32 AP implements a full MMU as specified by the AVR32 architecture. The page sizes provided are 1K, 4K, 64K and 1M. A 32-entry fully-associative common TLB is implemented, as well as a 4-entry micro-ITLB and 8-entry micro-DTLB. Instruction and data accesses perform lookups in the micro-TLBs. If the access misses in the micro-TLBs, an access in the common TLB is performed. If this access misses, a page miss exception is issued.

7.2.5 Caches and write buffer

AVR32 AP implements 16K data and 16K instruction caches. The caches are 4-way set associative. Each cache has a 32-bit System Bus master interface connecting it to the bus. The instruction cache has a 32-bit interface to the fetch pipeline stage, and the data cache has a 64-bit interface to the load-store pipeline. The caches use a least recently used allocate-on-read-miss replacement policy. The caches are virtually tagged, physically indexed, avoiding the need to flush them on task switch.

The caches provide locking on a per-line basis, allowing code and data to be permanently locked in the caches for timing-critical code. The data cache also allows prefetching of data using the *pref* instruction.

Accesses to the instruction and data caches are tagged as cacheable or uncacheable on a per-page basis by the MMU. Data cache writes are tagged as write-through or writeback on a per-page basis by the MMU.

The data cache has a 32-byte combining write buffer, to avoid stalling the CPU when writing to external memory. Writes are tagged as bufferable or unbufferable on a per-page basis by the MMU. Bufferable writes to sequential addresses are placed in the buffer, allowing for example a sequence of byte writes from the CPU to be combined into word transfers on the bus. A *sync* instruction is provided to explicitly flush the write buffer.

7.2.6 Unaligned reference handling

AVR32 AP has hardware support for performing unaligned memory accesses. This will reduce the memory footprint needed by some applications, as well as speed up other applications operating on unaligned data.

AVR32 AP is able to perform certain word-sized load and store instructions of any alignment, and word-aligned *st.d* and *ld.d*. Any other unaligned memory access will cause an MMU address exception. All coprocessor memory access instructions require word-aligned pointers. Double-word-sized accesses with word-aligned pointers will automatically be performed as two word-sized accesses.

The following table shows the instructions with support for unaligned addresses. All other instructions require aligned addresses. Accessing an unaligned address may require several clock cycles, refer to the *AVR32 AP Technical Reference Manual* for details.

Table 7-1. Instructions with unaligned reference support

Instruction	Supported alignment
ld.w	Any
st.w	Any
lddsp	Any
lddpc	Any
stdsp	Any
ld.d	Word
st.d	Word
All coprocessor memory access instruction	Word

7.2.7 Unimplemented instructions

The following instructions are unimplemented in AVR32 AP, and will cause an Unimplemented Instruction Exception if executed:

- mems
- memc
- memt

7.2.8 Exceptions and Interrupts

AVR32 AP incorporates a powerful exception handling scheme. The different exception sources, like Illegal Op-code and external interrupt requests, have different priority levels, ensuring a well-defined behavior when multiple exceptions are received simultaneously. Additionally, pending exceptions of a higher priority class may preempt handling of ongoing exceptions of a lower priority class. Each priority class has dedicated registers to keep the return address and status register thereby removing the need to perform time-consuming memory operations to save this information.

There are four levels of external interrupt requests, all executing in their own context. The INT3 context provides dedicated shadow registers ensuring low latency for these interrupts. An interrupt controller does the priority handling of the external interrupts and provides the autovector offset to the CPU.

The addresses and priority of simultaneous events are shown in [Table 7-2 on page 21](#).

Table 7-2. Priority and handler addresses for events

Priority	Handler Address	Name	Event source	Stored Return Address
1	0xA000_0000	Reset	External input	Undefined
2	Provided by OCD system	OCD Stop CPU	OCD system	First non-completed instruction
3	EVBA+0x00	Unrecoverable exception	Internal	PC of offending instruction
4	EVBA+0x04	TLB multiple hit	Internal signal	PC of offending instruction
5	EVBA+0x08	Bus error data fetch	Data bus	First non-completed instruction
6	EVBA+0x0C	Bus error instruction fetch	Data bus	First non-completed instruction
7	EVBA+0x10	NMI	External input	First non-completed instruction
8	Autovectored	Interrupt 3 request	External input	First non-completed instruction
9	Autovectored	Interrupt 2 request	External input	First non-completed instruction
10	Autovectored	Interrupt 1 request	External input	First non-completed instruction
11	Autovectored	Interrupt 0 request	External input	First non-completed instruction
12	EVBA+0x14	Instruction Address	ITLB	PC of offending instruction
13	EVBA+0x50	ITLB Miss	ITLB	PC of offending instruction
14	EVBA+0x18	ITLB Protection	ITLB	PC of offending instruction
15	EVBA+0x1C	Breakpoint	OCD system	First non-completed instruction
16	EVBA+0x20	Illegal Opcode	Instruction	PC of offending instruction
17	EVBA+0x24	Unimplemented instruction	Instruction	PC of offending instruction
18	EVBA+0x28	Privilege violation	Instruction	PC of offending instruction
19	EVBA+0x2C	Floating-point	FP Hardware	PC of offending instruction
20	EVBA+0x30	Coprocessor absent	Instruction	PC of offending instruction
21	EVBA+0x100	Supervisor call	Instruction	PC(Supervisor Call) +2
22	EVBA+0x34	Data Address (Read)	DTLB	PC of offending instruction
23	EVBA+0x38	Data Address (Write)	DTLB	PC of offending instruction
24	EVBA+0x60	DTLB Miss (Read)	DTLB	PC of offending instruction
25	EVBA+0x70	DTLB Miss (Write)	DTLB	PC of offending instruction
26	EVBA+0x3C	DTLB Protection (Read)	DTLB	PC of offending instruction
27	EVBA+0x40	DTLB Protection (Write)	DTLB	PC of offending instruction
28	EVBA+0x44	DTLB Modified	DTLB	PC of offending instruction

7.3 Programming Model

7.3.1 Register file configuration

The AVR32B architecture specifies that the exception contexts may have a different number of shadowed registers in different implementations. Figure 7-3 on page 22 shows the model used in AVR32 AP.

Figure 7-3. The AVR32 AP Register File

Application	Supervisor	INT0	INT1	INT2	INT3	Exception	NMI
Bit 31	Bit 0	Bit 31	Bit 0	Bit 31	Bit 0	Bit 31	Bit 0
PC	PC	PC	PC	PC	PC	PC	PC
LR	LR	LR	LR	LR	LR_INT3	LR	LR
SP_APP	SP_SYS	SP_SYS	SP_SYS	SP_SYS	SP_SYS	SP_SYS	SP_SYS
R12	R12	R12	R12	R12	R12_INT3	R12	R12
R11	R11	R11	R11	R11	R11_INT3	R11	R11
R10	R10	R10	R10	R10	R10_INT3	R10	R10
R9	R9	R9	R9	R9	R9_INT3	R9	R9
R8	R8	R8	R8	R8	R8_INT3	R8	R8
R7	R7	R7	R7	R7	R7	R7	R7
R6	R6	R6	R6	R6	R6	R6	R6
R5	R5	R5	R5	R5	R5	R5	R5
R4	R4	R4	R4	R4	R4	R4	R4
R3	R3	R3	R3	R3	R3	R3	R3
R2	R2	R2	R2	R2	R2	R2	R2
R1	R1	R1	R1	R1	R1	R1	R1
R0	R0	R0	R0	R0	R0	R0	R0
SR	SR	SR	SR	SR	SR	SR	SR
	RSR_SUP	RSR_INT0	RSR_INT1	RSR_INT2	RSR_INT3	RSR_EX	RSR_NMI
	RAR_SUP	RAR_INT0	RAR_INT1	RAR_INT2	RAR_INT3	RAR_EX	RAR_NMI

7.3.2 Status register configuration

The Status Register (SR) is splitted into two halfwords, one upper and one lower, see Figure 7-4 on page 22 and Figure 7-5 on page 23. The lower word contains the C, Z, N, V and Q condition code flags and the R, T and L bits, while the upper halfword contains information about the mode and state the processor executes in. Refer to the AVR32 Architecture Manual for details.

Figure 7-4. The Status Register High Halfword

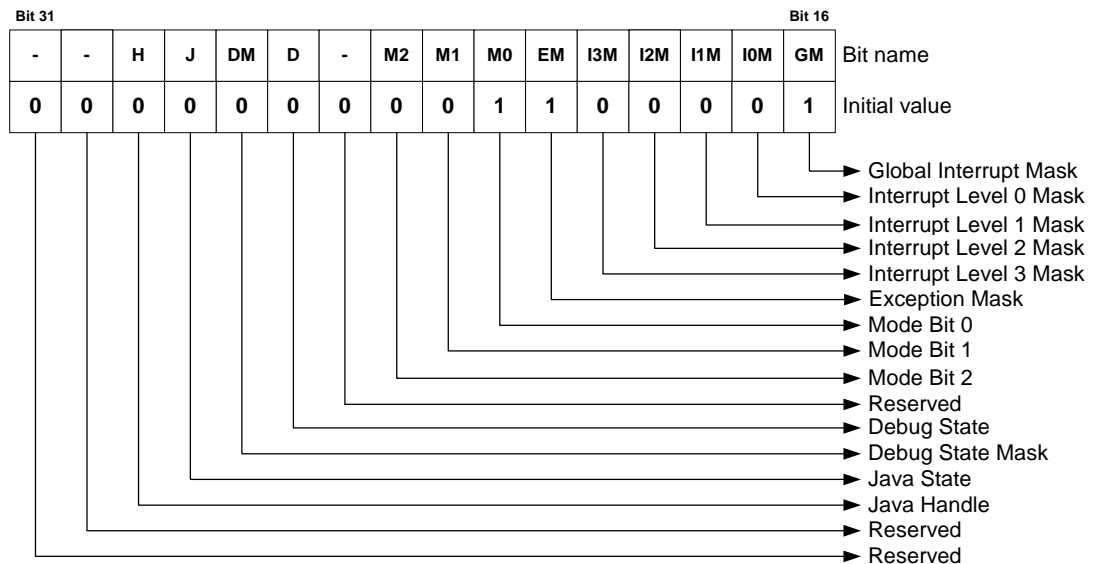
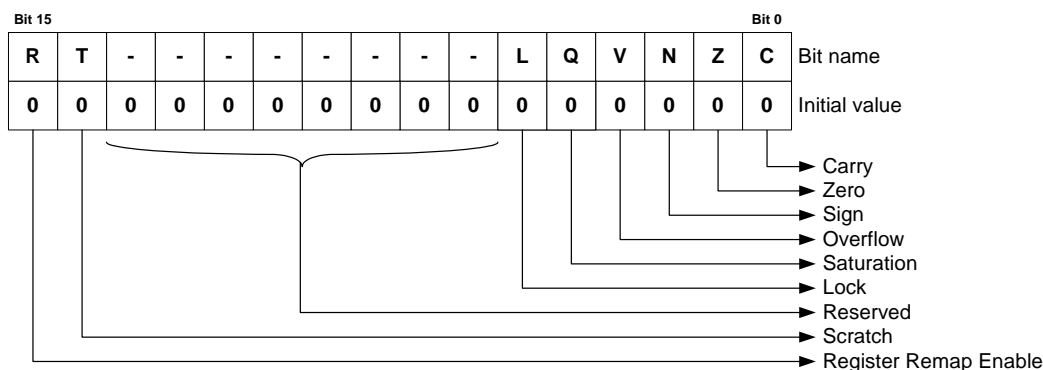

Figure 7-5. The Status Register Low Halfword



7.3.3 Processor States

7.3.3.1 Normal RISC State

The AVR32 processor supports several different execution contexts as shown in [Table 7-3 on page 23](#).

Table 7-3. Overview of execution modes, their priorities and privilege levels.

Priority	Mode	Security	Description
1	Non Maskable Interrupt	Privileged	Non Maskable high priority interrupt mode
2	Exception	Privileged	Execute exceptions
3	Interrupt 3	Privileged	General purpose interrupt mode
4	Interrupt 2	Privileged	General purpose interrupt mode
5	Interrupt 1	Privileged	General purpose interrupt mode
6	Interrupt 0	Privileged	General purpose interrupt mode
N/A	Supervisor	Privileged	Runs supervisor calls
N/A	Application	Unprivileged	Normal program execution mode

Mode changes can be made under software control, or can be caused by external interrupts or exception processing. A mode can be interrupted by a higher priority mode, but never by one with lower priority. Nested exceptions can be supported with a minimal software overhead.

When running an operating system on the AVR32, user processes will typically execute in the application mode. The programs executed in this mode are restricted from executing certain instructions. Furthermore, most system registers together with the upper halfword of the status register cannot be accessed. Protected memory areas are also not available. All other operating modes are privileged and are collectively called System Modes. They have full access to all privileged and unprivileged resources. After a reset, the processor will be in supervisor mode.

7.3.3.2 Debug State

The AVR32 can be set in a debug state, which allows implementation of software monitor routines that can read out and alter system information for use during application development. This implies that all system and application registers, including the status registers and program counters, are accessible in debug state. The privileged instructions are also available.

All interrupt levels are by default disabled when debug state is entered, but they can individually be switched on by the monitor routine by clearing the respective mask bit in the status register.

Debug state can be entered as described in the *AVR32 AP Technical Reference Manual*.

Debug state is exited by the *retd* instruction.

7.3.3.3 *Java State*

AVR32 AP implements a Java Extension Module (JEM). The processor can be set in a Java State where normal RISC operations are suspended. Refer to the *AVR32 Java Technical Reference Manual* for details.

8. Pixel Coprocessor (PiCo)

8.1 Features

- Coprocessor coupled to the AVR32 CPU Core through the TCB Bus.
- Three parallel Vector Multiplication Units (VMU) where each unit can:
 - Multiply three pixel components with three coefficients.
 - Add the products from the multiplications together.
 - Accumulate the result or add an offset to the sum of the products.
- Can be used for accelerating:
 - Image Color Space Conversion.
 - Configurable Conversion Coefficients.
 - Supports packed and planar input and output formats.
 - Supports subsampled input color spaces (i.e 4:2:2, 4:2:0).
 - Image filtering/scaling.
 - Configurable Filter Coefficients.
 - Throughput of one sample per cycle for a 9-tap FIR filter.
 - Can use the built-in accumulator to extend the FIR filter to more than 9-taps.
 - Can be used for bilinear/bicubic interpolations.
 - MPEG-4/H.264 Quarter Pixel Motion Compensation.
- Flexible input Pixel Selector.
 - Can operate on numerous different image storage formats.
- Flexible Output Pixel Inserter.
 - Scales and saturates the results back to 8-bit pixel values.
 - Supports packed and planar output formats.
- Configurable coefficients with flexible fixed-point representation.

8.2 Description

The Pixel Coprocessor (PiCo) is a coprocessor coupled to the AVR32 CPU through the TCB (Tightly Coupled Bus) interface. The PiCo consists of three Vector Multiplication Units (VMU0, VMU1, VMU2), an Input Pixel Selector and an Output Pixel Inserter. Each VMU can perform a vector multiplication of a 1x3 12-bit coefficient vector with a 3x1 8-bit pixel vector. In addition a 12-bit offset can be added to the result of this vector multiplication.

The PiCo can be used for transforming the pixel components in a given color space (i.e. RGB, YCrCb, YUV) to any other color space as long as the transformation is linear. The flexibility of the Input Pixel Selector and Output Pixel Insertion logic makes it easy to efficiently support different pixel storage formats with regards to issues such as byte ordering of the color components, if the color components constituting an image are packed/interleaved or stored as separate images or if any of the color components are subsampled.

The three Vector Multiplication Units can also be connected together to form one large vector multiplier which can perform a vector multiplication of a 1x9 12-bit coefficient vector with a 9x1 8-bit pixel vector. This can be used to implement FIR filters, bilinear interpolations filters for smoothing/scaling images etc. By allowing the outputs from the Vector Multiplication units to accumulate it is also possible to extend the order of the filter to more than 9-taps.

The results from the VMUs are scaled and saturated back to unsigned 8-bit pixel values in the Output Pixel Inserter.

The PiCo is divided into three pipeline stages with a throughput of one operation per cpu clock cycle.

8.3 Block Diagram

Figure 8-1. Pixel Coprocessor Block Diagram

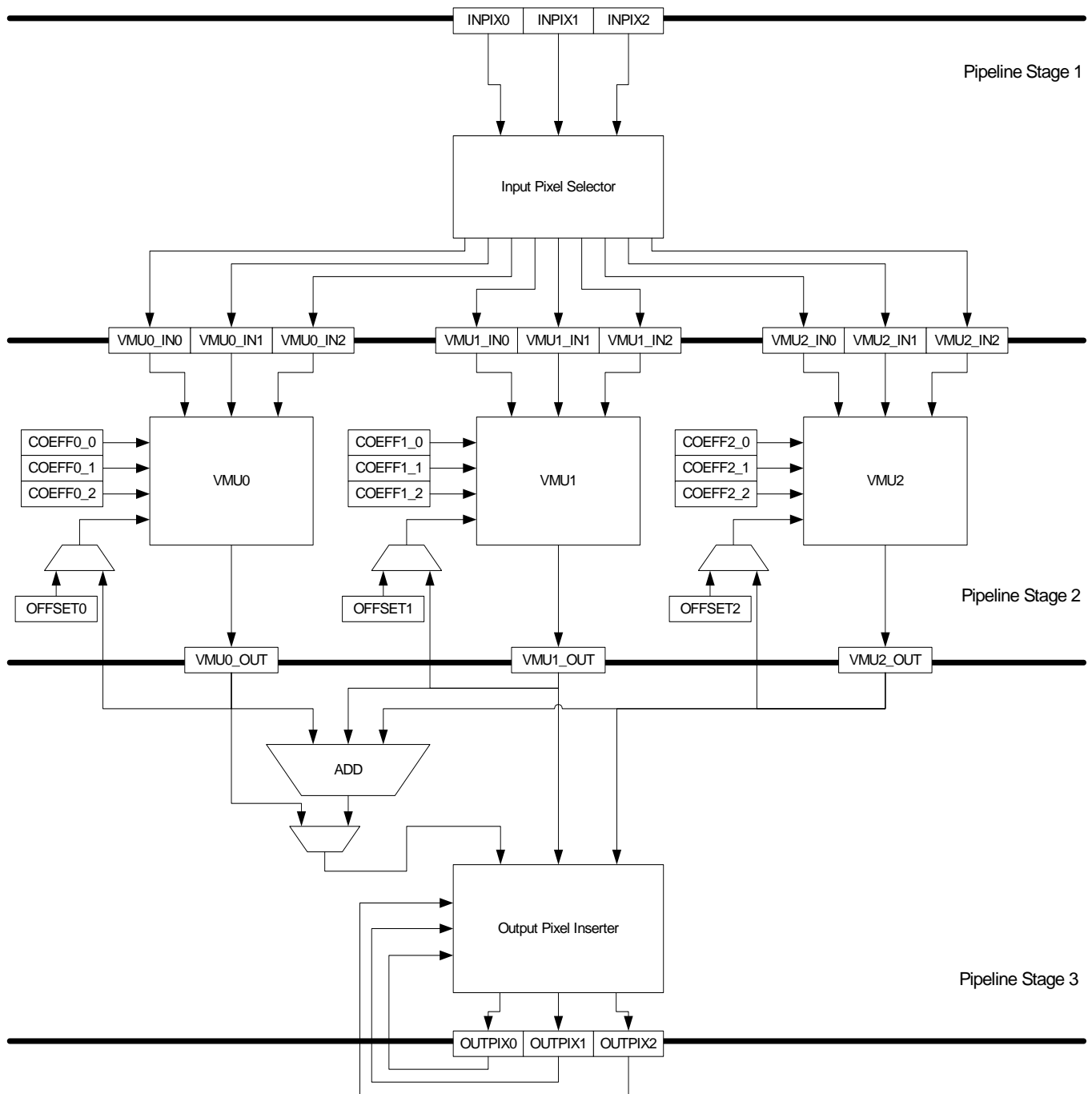

8.4 Vector Multiplication Unit (VMU)

Each VMU consists of three multipliers used for multiplying unsigned 8-bit pixel components with signed 12-bit coefficients. The result from each multiplication is a 20-bit signed number that is

input to a 22-bit vector adder along with an offset as shown in [Figure 8-2 on page 27](#). The operation is equal to the offsetted vector multiplication given in the following equation:

$$vmu_out = \begin{bmatrix} coeff0 & coeff1 & coeff2 \end{bmatrix} \begin{bmatrix} vmu_in0 \\ vmu_in1 \\ vmu_in2 \end{bmatrix} + offset$$

Figure 8-2. Inside VMU_n ($n \in \{0,1,2\}$)

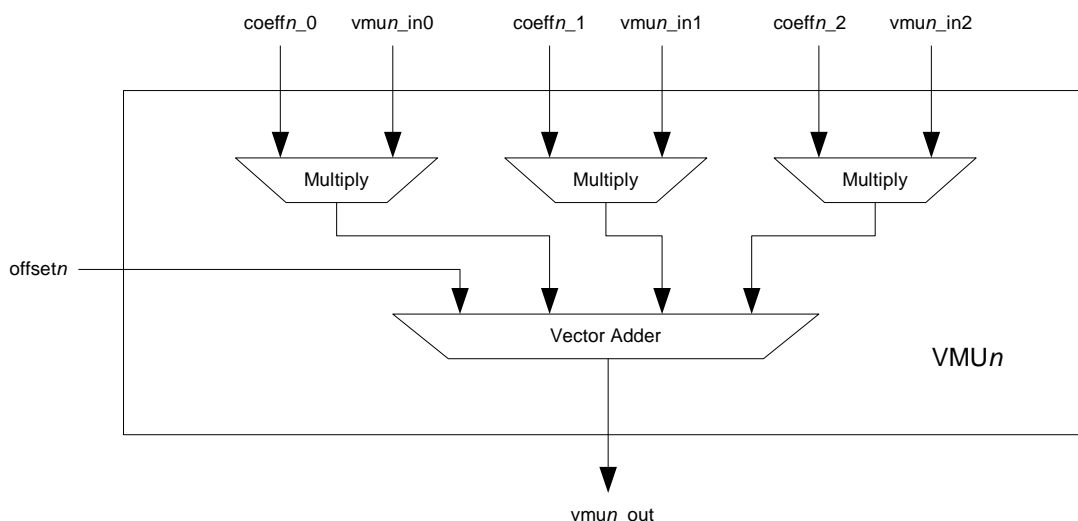

8.5 Input Pixel Selector

The Input Pixel Selector uses the ISM (Input Selection Mode) field in the CONFIG register and the three input pixel source addresses given in the PiCo operation instructions to decide which pixels to select for inputs to the VMUs.

8.5.1 Transformation Mode

When the Input Selection Mode is set to Transformation Mode the input pixel source addresses IN_x, IN_y and IN_z directly maps to three pixels in the INPIX_n registers. These three pixels are then input to each of the VMUs. The following expression then represents what is computed by the VMUs in Transformation Mode:

$$\begin{bmatrix} VMU0_OUT \\ VMU1_OUT \\ VMU2_OUT \end{bmatrix} = \begin{bmatrix} COEFF0_0 & COEFF0_1 & COEFF0_2 \\ COEFF1_0 & COEFF1_1 & COEFF1_2 \\ COEFF2_0 & COEFF2_1 & COEFF2_2 \end{bmatrix} \begin{bmatrix} INx \\ INy \\ INz \end{bmatrix} + \begin{bmatrix} OFFSET0 \text{ or } VMU0_OUT \\ OFFSET1 \text{ or } VMU1_OUT \\ OFFSET2 \text{ or } VMU2_OUT \end{bmatrix}$$

8.5.2 Horizontal Filter Mode

In Horizontal Filter Mode the input pixel source addresses IN_x, IN_y and IN_z represents the base pixel address of a pixel triplet. The pixel triplet {IN(x), IN(x+1), IN(x+2)} is input to VMU0, the pixel triplet {IN(y), IN(y+1), IN(y+2)} is input to VMU1 and the pixel triplet {IN(z), IN(z+1), IN(z+2)} is input to VMU2. [Figure 8-3 on page 28](#) shows how the pixel triplet is found by taking the pixel addressed by the base address and following the arrow to find the next two pixels which makes up the triplet.

Figure 8-3. Horizontal Filter Mode Pixel Addressing

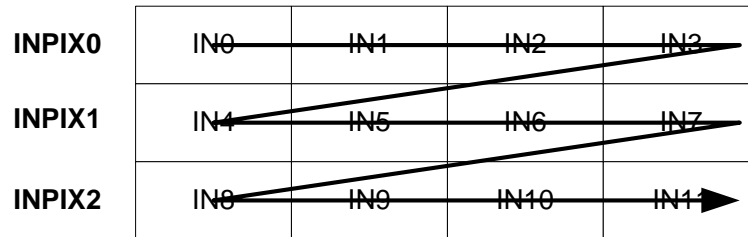

The following expression represents what is computed by the VMUs in Horizontal Filter Mode:

$$VMU0_OUT = [COEFF0_0 \ COEFF0_1 \ COEFF0_2] \begin{bmatrix} IN(x+0) \\ IN(x+1) \\ IN(x+2) \end{bmatrix} + (OFFSET0 \text{ or } VMU0_OUT)$$

$$VMU1_OUT = [COEFF1_0 \ COEFF1_1 \ COEFF1_2] \begin{bmatrix} IN(y+0) \\ IN(y+1) \\ IN(y+2) \end{bmatrix} + (OFFSET1 \text{ or } VMU1_OUT)$$

$$VMU2_OUT = [COEFF2_0 \ COEFF2_1 \ COEFF2_2] \begin{bmatrix} IN(z+0) \\ IN(z+1) \\ IN(z+2) \end{bmatrix} + (OFFSET2 \text{ or } VMU2_OUT)$$

8.5.3 Vertical Filter Mode

In Vertical Filter Mode the input pixel source addresses INx, INy and INz represent the base of a pixel triplet found by following the vertical arrow shown in Figure 8-4 on page 28. The pixel triplet {IN(x), IN((x+4)%11), IN((x+8)%11)} is input to VMU0, the pixel triplet {IN(y), IN((y+4)%11), IN((y+8)%11)} is input to VMU1 and the pixel triplet {IN(z), IN((z+4)%11), IN((z+8)%11)} is input to VMU2.

Figure 8-4. Vertical Filter Mode Pixel Addressing

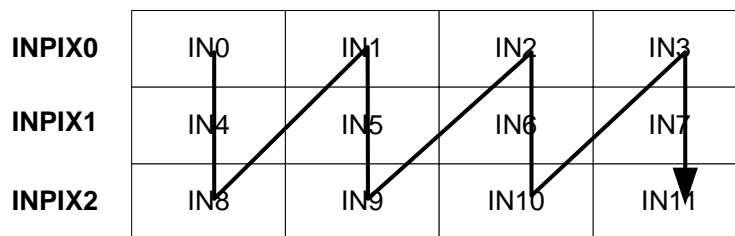

The following expression represents what is computed by the VMUs in Vertical Filter Mode:

$$\begin{aligned}
 \text{VMU0_OUT} &= [\text{COEFF0_0} \text{ COEFF0_1} \text{ COEFF0_2}] \begin{bmatrix} \text{IN}((x+0)\%11) \\ \text{IN}((x+4)\%11) \\ \text{IN}((x+8)\%11) \end{bmatrix} + (\text{OFFSET0 or VMU0_OUT}) \\
 \text{VMU1_OUT} &= [\text{COEFF1_0} \text{ COEFF1_1} \text{ COEFF1_2}] \begin{bmatrix} \text{IN}((y+0)\%11) \\ \text{IN}((y+4)\%11) \\ \text{IN}((y+8)\%11) \end{bmatrix} + (\text{OFFSET1 or VMU1_OUT}) \\
 \text{VMU2_OUT} &= [\text{COEFF2_0} \text{ COEFF2_1} \text{ COEFF2_2}] \begin{bmatrix} \text{IN}((z+0)\%11) \\ \text{IN}((z+4)\%11) \\ \text{IN}((z+8)\%11) \end{bmatrix} + (\text{OFFSET2 or VMU2_OUT})
 \end{aligned}$$

8.6 Output Pixel Inserter

The Output Pixel Inserter uses the OIM (Output Insertion Mode) field in the CONFIG register and the destination pixel address given in the PiCo operation instructions to decide which three of the twelve possible OUT n pixels to write back the scaled and saturated results from the VMUs to. The 22-bit results from each VMU is first scaled by performing an arithmetical right shift by COEFF_FRAC_BITS in order to remove the fractional part of the results and obtain the integer part. The integer part is then saturated to an unsigned 8-bit number in the range 0 to 255.

8.6.1 Planar Insertion Mode

In Planar Insertion Mode the destination pixel address OUT d specifies which pixel in each of the registers OUTPIX0, OUTPIX1 and OUTPIX2 will be updated. VMU n writes to OUTPIX n . This can be seen in [Figure 8-5 on page 29](#) and [Table 8-2 on page 47](#). This mode is useful when transforming from one color space to another where the resulting color components should be stored in separate images.

Figure 8-5. Planar Pixel Insertion

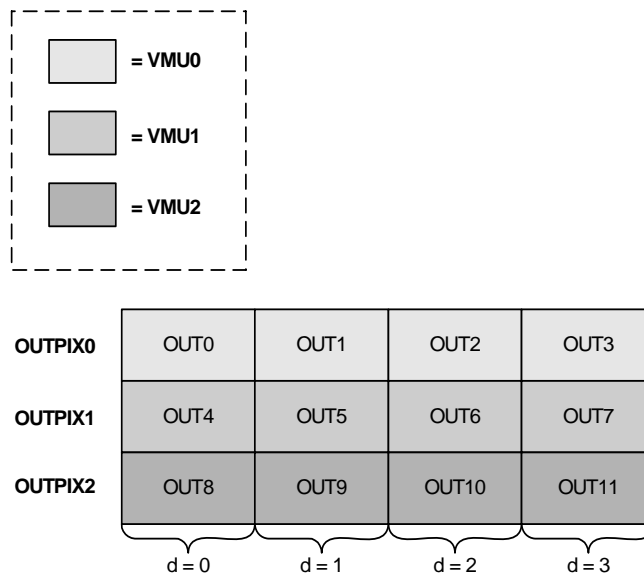

8.6.2 Packed Insertion Mode

In Packed Insertion Mode the three output registers OUTPIX0, OUTPIX1 and OUTPIX2 are divided into four pixel triplets as seen in Figure 8-6 on page 30 and Table 8-2 on page 47. The destination pixel address is then the address of the pixel triplet. VMU n writes to pixel n of the pixel triplet. This mode is useful when transforming from one color space to another where the resulting color components should be packed together.

Figure 8-6. Packed Pixel Insertion.

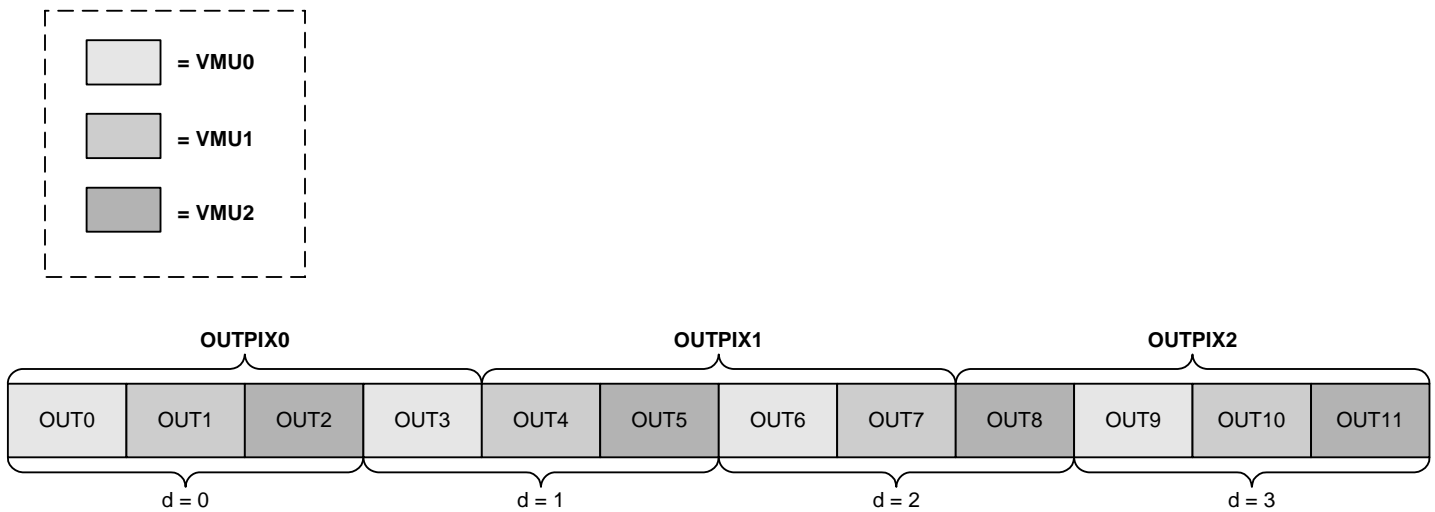

8.7 User Interface

The PiCo uses the TCB interface to communicate with the CPU and the user can read from or write to the PiCo Register File by using the PiCo load/store/move instructions which maps to generic coprocessor instructions.

8.7.1 Register File

The PiCo register file can be accessed from the CPU by using the *picomv.x*, *picold.x*, *picost.x*, *picoldm* and *picostm* instructions.

Table 8-1. PiCo Register File

Cp Reg #	Register	Name	Access
cr0	Input Pixel Register 2	INPIX2	Read/Write
cr1	Input Pixel Register 1	INPIX1	Read/Write
cr2	Input Pixel Register 0	INPIX0	Read/Write
cr3	Output Pixel Register 2	OUTPIX2	Read Only
cr4	Output Pixel Register 1	OUTPIX1	Read Only
cr5	Output Pixel Register 0	OUTPIX0	Read Only
cr6	Coefficient Register A for VMU0	COEFF0_A	Read/Write
cr7	Coefficient Register B for VMU0	COEFF0_B	Read/Write
cr8	Coefficient Register A for VMU1	COEFF1_A	Read/Write
cr9	Coefficient Register B for VMU1	COEFF1_B	Read/Write
cr10	Coefficient Register A for VMU2	COEFF2_A	Read/Write
cr11	Coefficient Register B for VMU2	COEFF2_B	Read/Write
cr12	Output from VMU0	VMU0_OUT	Read/Write
cr13	Output from VMU1	VMU1_OUT	Read/Write
cr14	Output from VMU2	VMU2_OUT	Read/Write
cr15	PiCo Configuration Register	CONFIG	Read/Write

8.7.1.1 Input Pixel Register 0

Register Name: INPIX0

Access Type: Read/Write

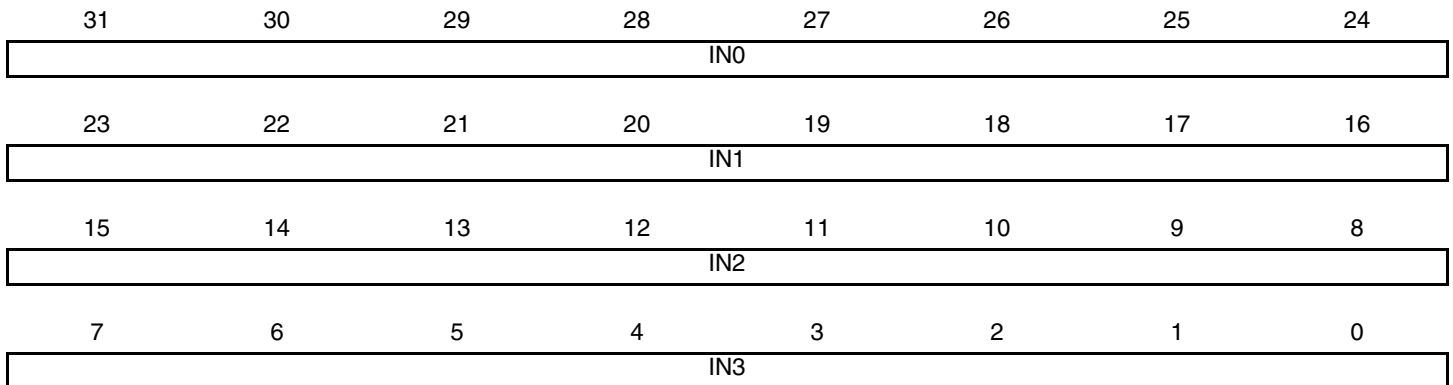

- **IN0: Input Pixel 0**

Input Pixel number 0 to the Input Pixel Selector Unit.

- **IN1: Input Pixel 1**

Input Pixel number 1 to the Input Pixel Selector Unit.

- **IN2: Input Pixel 2**

Input Pixel number 2 to the Input Pixel Selector Unit.

- **IN3: Input Pixel 3**

Input Pixel number 3 to the Input Pixel Selector Unit.

8.7.1.2 Input Pixel Register 1

Register Name: INPIX1

Access Type: Read/Write

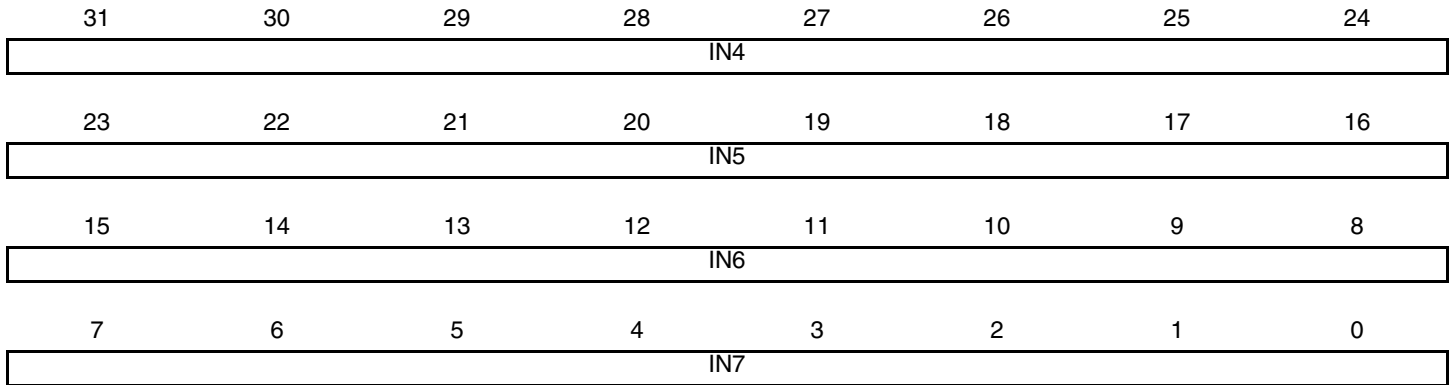

- **IN0: Input Pixel 4**

Input Pixel number 4 to the Input Pixel Selector Unit.

- **IN1: Input Pixel 5**

Input Pixel number 5 to the Input Pixel Selector Unit.

- **IN2: Input Pixel 6**

Input Pixel number 6 to the Input Pixel Selector Unit.

- **IN3: Input Pixel 7**

Input Pixel number 7 to the Input Pixel Selector Unit.

8.7.1.3 Input Pixel Register 2

Register Name: INPIX2

Access Type: Read/Write

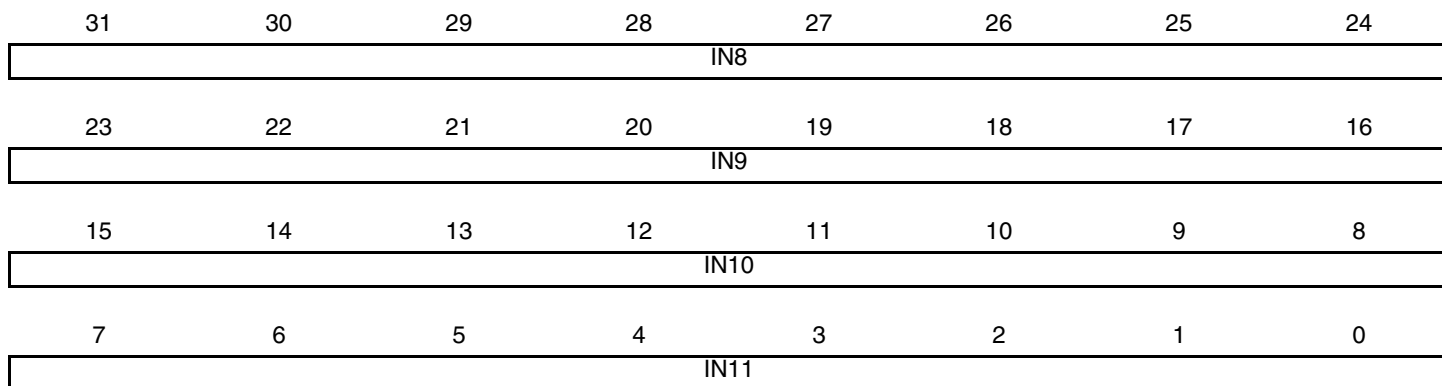

- **IN0: Input Pixel 8**

Input Pixel number 8 to the Input Pixel Selector Unit.

- **IN1: Input Pixel 9**

Input Pixel number 9 to the Input Pixel Selector Unit.

- **IN2: Input Pixel 10**

Input Pixel number 10 to the Input Pixel Selector Unit.

- **IN3: Input Pixel 11**

Input Pixel number 11 to the Input Pixel Selector Unit.

8.7.1.4 Output Pixel Register 0

Register Name: OUTPIX0

Access Type: Read

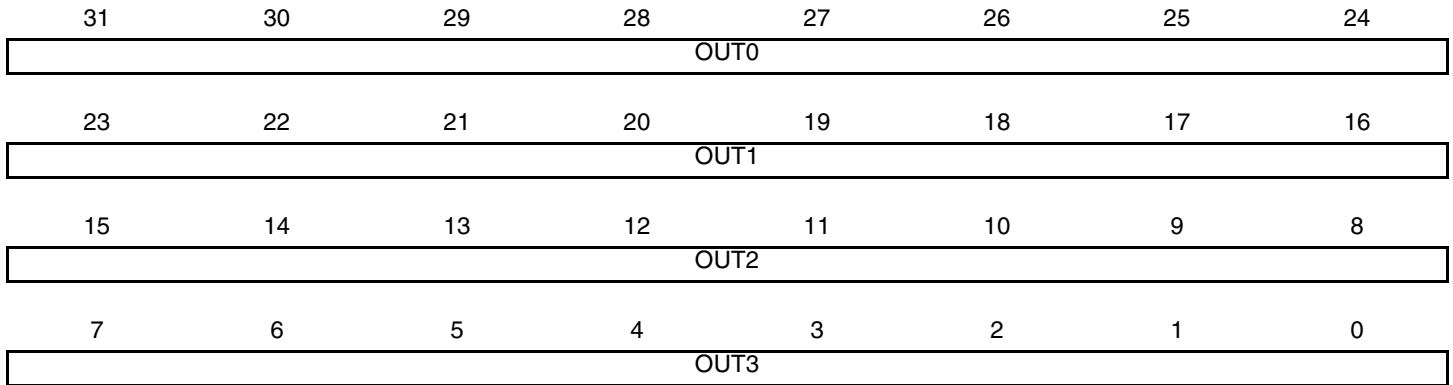

- **OUT0: Output Pixel 0**

Output Pixel number 0 from the Output Pixel Inserter Unit.

- **OUT1: Output Pixel 1**

Output Pixel number 1 from the Output Pixel Inserter Unit.

- **OUT2: Output Pixel 2**

Output Pixel number 2 from the Output Pixel Inserter Unit.

- **OUT3: Output Pixel 3**

Output Pixel number 3 from the Output Pixel Inserter Unit.

8.7.1.5 Output Pixel Register 1

Register Name: OUTPIX1

Access Type: Read

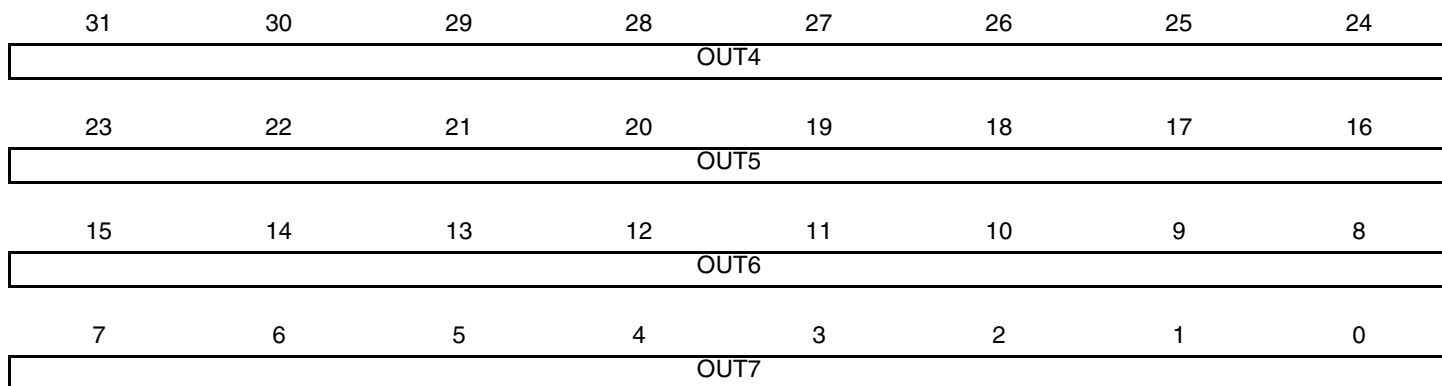

- **OUT4: Output Pixel 4**

Output Pixel number 4 from the Output Pixel Inserter Unit.

- **OUT5: Output Pixel 5**

Output Pixel number 5 from the Output Pixel Inserter Unit.

- **OUT6: Output Pixel 6**

Output Pixel number 6 from the Output Pixel Inserter Unit.

- **OUT7: Output Pixel 7**

Output Pixel number 7 from the Output Pixel Inserter Unit.

8.7.1.6 Output Pixel Register 2

Register Name: OUTPIX2

Access Type: Read

31	30	29	28	27	26	25	24
OUT8							
23	22	21	20	19	18	17	16
OUT9							
15	14	13	12	11	10	9	8
OUT10							
7	6	5	4	3	2	1	0
OUT11							

- **OUT8: Output Pixel 8**

Output Pixel number 8 from the Output Pixel Inserter Unit.

- **OUT9: Output Pixel 9**

Output Pixel number 9 from the Output Pixel Inserter Unit.

- **OUT10: Output Pixel 10**

Output Pixel number 10 from the Output Pixel Inserter Unit.

- **OUT11: Output Pixel 11**

Output Pixel number 11 from the Output Pixel Inserter Unit.

8.7.1.7 Coefficient Register A for VMU0

Register Name: COEFF0_A

Access Type: Read/Write

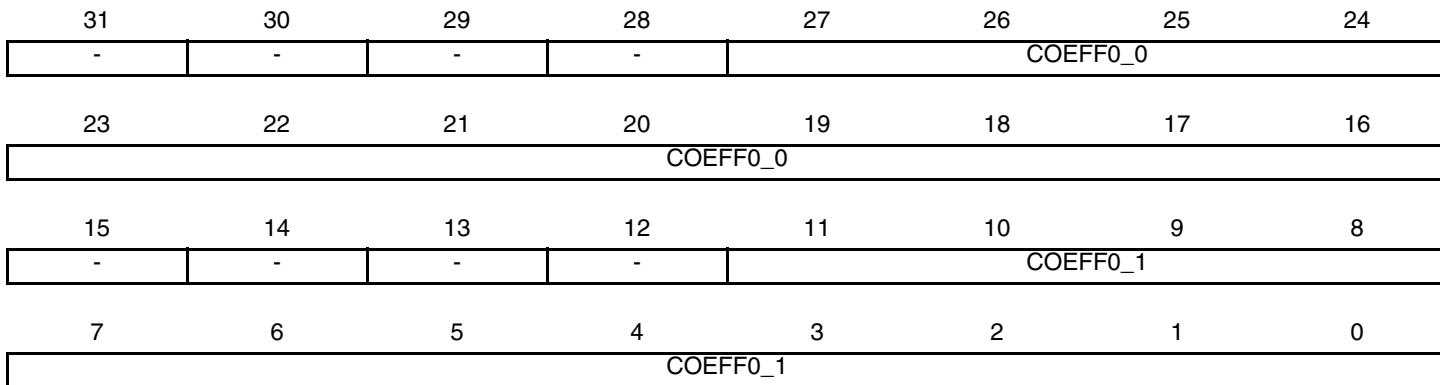

- **COEFF0_0: Coefficient 0 for VMU0**

Coefficient 0 input to VMU0. A signed 12-bit fixed-point number where the number of fractional bits is given by the COEFF_FRAC_BITS field in the CONFIG register. The actual fractional number is equal to $COEFF0_0 / 2^{COEFF_FRAC_BITS}$, where the COEFF0_0 value is interpreted as a 2's complement integer. When reading this register, COEFF0_0 is sign-extended to 16-bits in order to fill in the unused bits in the upper halfword of this register.

- **COEFF0_1: Coefficient 1 for VMU0**

Coefficient 1 input to VMU0. A signed 12-bit fixed-point number where the number of fractional bits is given by the COEFF_FRAC_BITS field in the CONFIG register. The actual fractional number is equal to $COEFF0_1 / 2^{COEFF_FRAC_BITS}$, where the COEFF0_1 value is interpreted as a 2's complement integer. When reading this register, COEFF0_1 is sign-extended to 16-bits in order to fill in the unused bits in the lower halfword of this register.

8.7.1.8 Coefficient Register B for VMU0

Register Name: COEFF0_B

Access Type: Read/Write

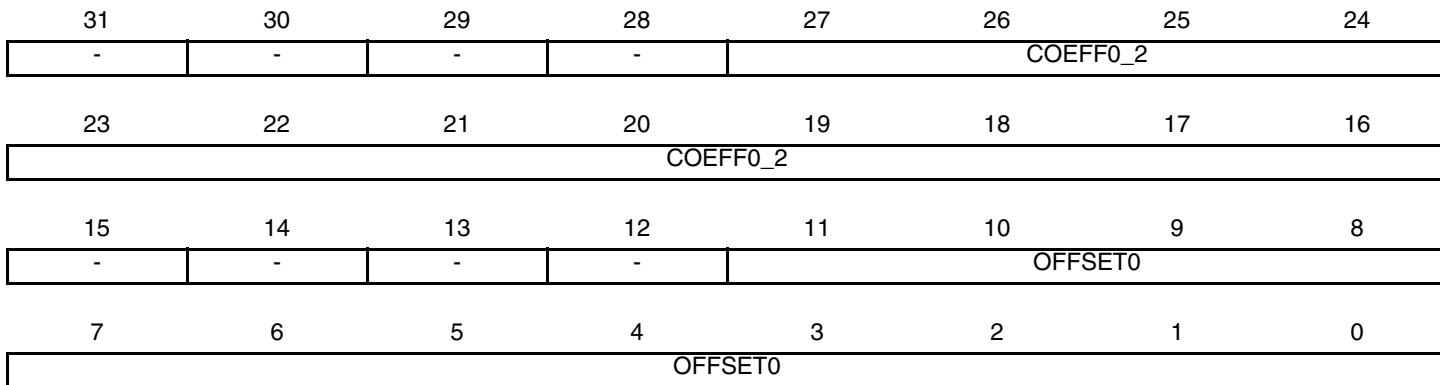

- **COEFF0_2: Coefficient 2 for VMU0**

Coefficient 2 input to VMU0. A signed 12-bit fixed-point number where the number of fractional bits is given by the COEFF_FRAC_BITS field in the CONFIG register. The actual fractional number is equal to $COEFF0_2 / 2^{COEFF_FRAC_BITS}$, where the COEFF0_2 value is interpreted as a 2's complement integer. When reading this register, COEFF0_2 is sign-extended to 16-bits in order to fill in the unused bits in the upper halfword of this register.

- **OFFSET0: Offset for VMU0**

Offset input to VMU0 in case of non-accumulating operations. A signed 12-bit fixed-point number where the number of fractional bits is given by the OFFSET_FRAC_BITS field in the CONFIG register. The actual fractional number is equal to $OFFSET0 / 2^{OFFSET_FRAC_BITS}$, where the OFFSET0 value is interpreted as a 2's complement integer. When reading this register, OFFSET0 is sign-extended to 16-bits in order to fill in the unused bits in the lower halfword of this register.

8.7.1.9 Coefficient Register A for VMU1

Register Name: COEFF1_A

Access Type: Read/Write

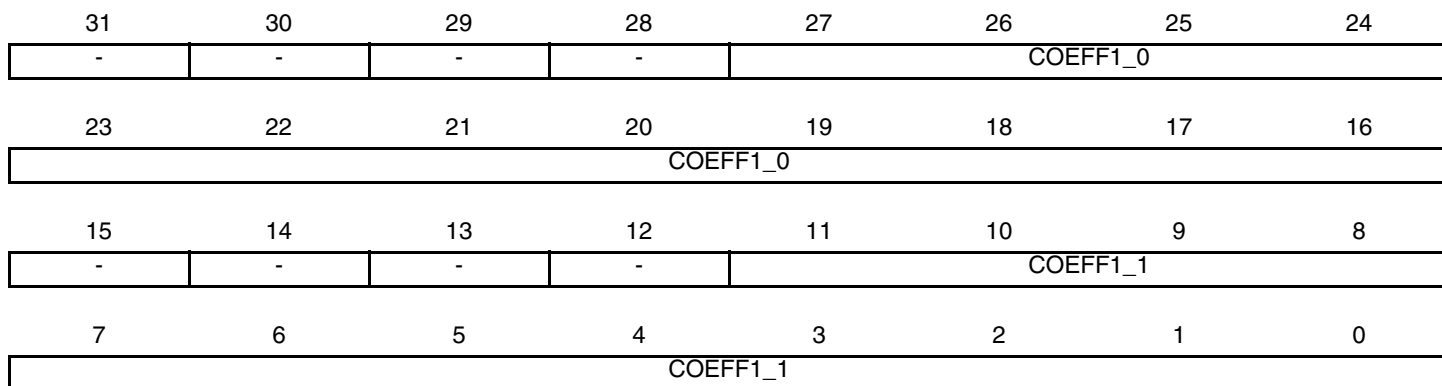

- **COEFF1_0: Coefficient 0 for VMU1**

Coefficient 0 input to VMU1. A signed 12-bit fixed-point number where the number of fractional bits is given by the COEFF_FRAC_BITS field in the CONFIG register. The actual fractional number is equal to $COEFF1_0 / 2^{COEFF_FRAC_BITS}$, where the COEFF1_0 value is interpreted as a 2's complement integer. When reading this register, COEFF1_0 is sign-extended to 16-bits in order to fill in the unused bits in the upper halfword of this register.

- **COEFF1_1: Coefficient 1 for VMU1**

Coefficient 1 input to VMU0. A signed 12-bit fixed-point number where the number of fractional bits is given by the COEFF_FRAC_BITS field in the CONFIG register. The actual fractional number is equal to $COEFF1_1 / 2^{COEFF_FRAC_BITS}$, where the COEFF1_1 value is interpreted as a 2's complement integer. When reading this register, COEFF1_1 is sign-extended to 16-bits in order to fill in the unused bits in the lower halfword of this register.

8.7.1.10 Coefficient Register B for VMU1

Register Name: COEFF1_B

Access Type: Read/Write

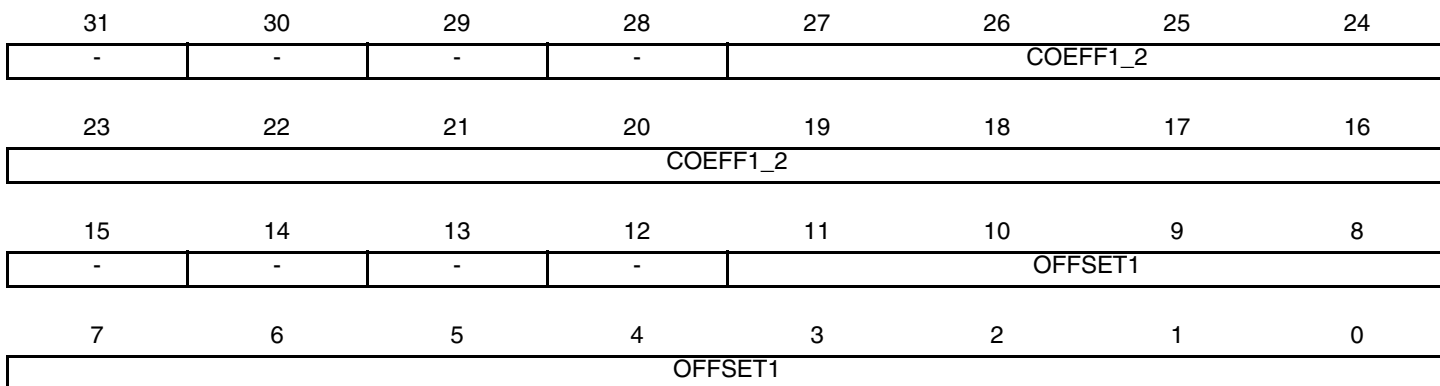

- **COEFF1_2: Coefficient 2 for VMU1**

Coefficient 2 input to VMU1. A signed 12-bit fixed-point number where the number of fractional bits is given by the COEFF_FRAC_BITS field in the CONFIG register. The actual fractional number is equal to $COEFF1_2 / 2^{COEFF_FRAC_BITS}$, where the COEFF1_2 value is interpreted as a 2's complement integer. When reading this register, COEFF1_2 is sign-extended to 16-bits in order to fill in the unused bits in the upper halfword of this register.

- **OFFSET1: Offset for VMU1**

Offset input to VMU1 in case of non-accumulating operations. A signed 12-bit fixed-point number where the number of fractional bits is given by the OFFSET_FRAC_BITS field in the CONFIG register. The actual fractional number is equal to $OFFSET1 / 2^{OFFSET_FRAC_BITS}$, where the OFFSET1 value is interpreted as a 2's complement integer. When reading this register, OFFSET1 is sign-extended to 16-bits in order to fill in the unused bits in the lower halfword of this register.

8.7.1.11 Coefficient Register A for VMU2

Register Name: COEFF2_A

Access Type: Read/Write

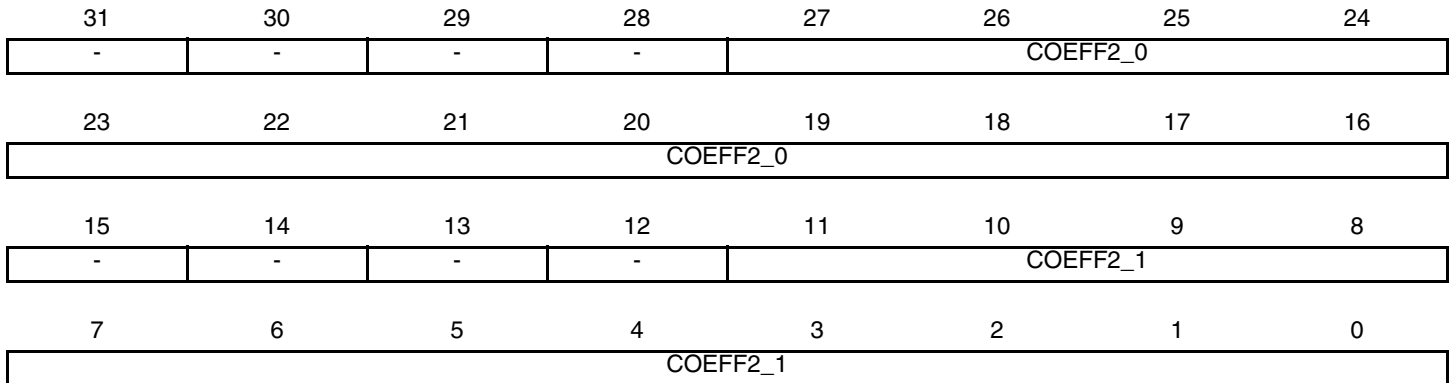

- **COEFF2_0: Coefficient 0 for VMU2**

Coefficient 0 input to VMU2. A signed 12-bit fixed-point number where the number of fractional bits is given by the COEFF_FRAC_BITS field in the CONFIG register. The actual fractional number is equal to $COEFF2_0 / 2^{COEFF_FRAC_BITS}$, where the COEFF2_0 value is interpreted as a 2's complement integer. When reading this register, COEFF2_0 is sign-extended to 16-bits in order to fill in the unused bits in the upper halfword of this register.

- **COEFF2_1: Coefficient 1 for VMU2**

Coefficient 1 input to VMU2. A signed 12-bit fixed-point number where the number of fractional bits is given by the COEFF_FRAC_BITS field in the CONFIG register. The actual fractional number is equal to $COEFF2_1 / 2^{COEFF_FRAC_BITS}$, where the COEFF2_1 value is interpreted as a 2's complement integer. When reading this register, COEFF2_1 is sign-extended to 16-bits in order to fill in the unused bits in the lower halfword of this register.

8.7.1.12 Coefficient Register B for VMU2

Register Name: COEFF2_B

Access Type: Read/Write

31	30	29	28	27	26	25	24
-	-	-	-	COEFF2_2			
23	22	21	20	19	18	17	16
COEFF2_2							
15	14	13	12	11	10	9	8
-	-	-	-	OFFSET2			
7	6	5	4	3	2	1	0
OFFSET2							

- **COEFF2_2: Coefficient 2 for VMU2**

Coefficient 2 input to VMU2. A signed 12-bit fixed-point number where the number of fractional bits is given by the COEFF_FRAC_BITS field in the CONFIG register. The actual fractional number is equal to $COEFF2_2 / 2^{COEFF_FRAC_BITS}$, where the COEFF2_2 value is interpreted as a 2's complement integer. When reading this register, COEFF2_2 is sign-extended to 16-bits in order to fill in the unused bits in the upper halfword of this register.

- **OFFSET2: Offset for VMU2**

Offset input to VMU2 in case of non-accumulating operations. A signed 12-bit fixed-point number where the number of fractional bits is given by the OFFSET_FRAC_BITS field in the CONFIG register. The actual fractional number is equal to $OFFSET2 / 2^{OFFSET_FRAC_BITS}$, where the OFFSET2 value is interpreted as a 2's complement integer. When reading this register, OFFSET2 is sign-extended to 16-bits in order to fill in the unused bits in the lower halfword of this register.

8.7.1.13 VMU0 Output Register

Register Name: VMU0_OUT

Access Type: Read/Write

31	30	29	28	27	26	25	24
-	-	-	-	-	-	-	-
23	22	21	20	19	18	17	16
-	-	VMU0_OUT					
15	14	13	12	11	10	9	8
VMU0_OUT							
7	6	5	4	3	2	1	0
VMU0_OUT							

- **VMU0_OUT: Output from VMU0**

This register is used for directly accessing the output from VMU0 or for setting the initial value of the accumulator for accumulating operations. The output from VMU0 is a signed 22-bit fixed-point number where the number of fractional bits are given by the COEFF_FRAC_BITS field in the CONFIG register. When reading this register the signed 22-bit value is sign-extended to 32-bits.

8.7.1.14 VMU1 Output Register

Register Name: VMU1_OUT

Access Type: Read/Write

31	30	29	28	27	26	25	24
-	-	-	-	-	-	-	-
23	22	21	20	19	18	17	16
-	-	VMU1_OUT					
15	14	13	12	11	10	9	8
VMU1_OUT							
7	6	5	4	3	2	1	0
VMU1_OUT							

• **VMU1_OUT: Output from VMU1**

This register is used for directly accessing the output from VMU1 or for setting the initial value of the accumulator for accumulating operations. The output from VMU1 is a signed 22-bit fixed-point number where the number of fractional bits are given by the COEFF_FRAC_BITS field in the CONFIG register. When reading this register the signed 22-bit value is sign-extended to 32-bits.

8.7.1.15 VMU2 Output Register

Register Name: VMU2_OUT

Access Type: Read/Write

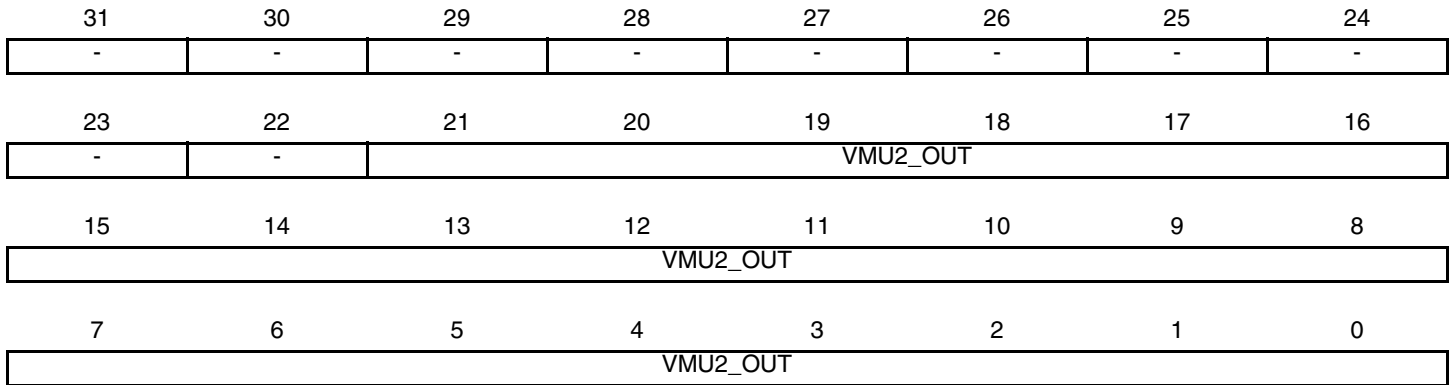

• VMU2_OUT: Output from VMU2

This register is used for directly accessing the output from VMU2 or for setting the initial value of the accumulator for accumulating operations. The output from VMU2 is a signed 22-bit fixed-point number where the number of fractional bits are given by the COEFF_FRAC_BITS field in the CONFIG register. When reading this register the signed 22-bit value is sign-extended to 32-bits.

8.7.1.16 PiCo Configuration Register

Register Name: CONFIG

Access Type: Read/Write

31	30	29	28	27	26	25	24
-	-	-	-	-	-	-	-
23	22	21	20	19	18	17	16
-	-	-	-	-	-	-	-
15	14	13	12	11	10	9	8
-	-	-	-	-	OIM	ISM	
7	6	5	4	3	2	1	0
OFFSET_FRAC_BITS				COEFF_FRAC_BITS			

• OIM: Output Insertion Mode

The OIM bit specifies the semantics of the OUTd output pixel address parameter to the *pico(s)v(mul/mac)* instructions. The OIM together with the output pixel address parameter specify which of the 12 output bytes (OUTn) of the OUTPIXn registers will be updated with the results from the VMUs. [Table 8-2 on page 47](#) describes the different Output Insertion Modes. See [Section 8.6 "Output Pixel Inserter" on page 29](#) for a description of the Output Pixel Inserter.

Table 8-2. Output Insertion Modes

OIM	Mode	Description
0	Packed Insertion Mode	<p>{OUTPIX0, OUTPIX1, OUTPIX2} is treated as one large register containing 4 sequential 24-bit pixel triplets. The DST_ADR field specifies which of the sequential triplets will be updated.</p> <p>$OUT(d*3 + 0) \leftarrow$ Scaled and saturated output from VMU0</p> <p>$OUT(d*3 + 1) \leftarrow$ Scaled and saturated output from VMU1</p> <p>$OUT(d*3 + 2) \leftarrow$ Scaled and saturated output from VMU2</p>
1	Planar Insertion Mode	<p>Each of the OUTPIXn registers will get one of the resulting pixels. The triplet address specifies what byte in each of the OUTPIXn registers the results will be written to.</p> <p>$OUT(d + 0) \leftarrow$ Scaled and saturated output from VMU0</p> <p>$OUT(d + 4) \leftarrow$ Scaled and saturated output from VMU1</p> <p>$OUT(d + 8) \leftarrow$ Scaled and saturated output from VMU2</p>

• ISM: Input Selection Mode

The ISM field specifies the semantics of the input pixel address parameters INx, INy and INz to the *pico(s)v(mul/mac)* instructions. Together with the three input pixel addresses the ISM field specifies to the Input Pixel Selector which of the input pixels (INn) that should be selected as inputs to the VMUs. [Table 8-3 on page 48](#) describes the

different Input Selection Modes. See [Section 8.5 "Input Pixel Selector"](#) on page 27 for a description of the Input Pixel

Table 8-3. Input Selection Modes

ISM		Mode	
0	0	Transformation Mode	VMU0, VMU1 and VMU2 get the same pixel inputs. These three pixels can be freely selected from the INPIX n registers.
0	1	Horizontal Filter Mode	Pixel triplets are selected for input to each of the VMUs by addressing horizontal pixel triplets from the INPIX n registers.
1	0	Vertical Filter Mode	Pixel triplets are selected for input to each of the VMUs by addressing vertical pixel triplets from the INPIX n registers.
1	1	Reserved	N.A

Selector.

- **OFFSET_FRAC_BITS: Offset Fractional Bits**

Specifies the number of fractional bits in the fixed-point offsets input to each VMU. Must be in the range from 0 to COEFF_FRAC_BITS. Other values gives undefined results. This value is used for scaling the OFFSET n values before being input to VMU n so that the offset will have the same fixed-point format as the outputs from the multiplication stages before performing the vector addition in the VMU.

- **COEFF_FRAC_BITS: Coefficient Fractional Bits**

Specifies the number of fractional bits in the fixed-point coefficients input to each VMU. Must be in the range from 0 to 11, since at least one bit of the coefficient must be used for the sign. Other values gives undefined results. COEFF_FRAC_BITS is used in the Output Pixel Inserter to scale the fixed-point results from the VMUs back to unsigned 8-bit integers.

8.8 PiCo Instructions

8.8.1 PiCo Instructions Nomenclature

8.8.1.1 Registers and Operands

R {d, s, ...}	The uppercase ' R ' denotes a 32-bit (word) register.
Rd	The lowercase ' d ' denotes the <i>destination</i> register number.
Rs	The lowercase ' s ' denotes the <i>source</i> register number.
Rb	The lowercase ' b ' denotes the <i>base</i> register number for indexed addressing modes.
Ri	The lowercase ' i ' denotes the <i>index</i> register number for indexed addressing modes.
Rp	The lowercase ' p ' denotes the <i>pointer</i> register number.
IN {x, y, z}	The uppercase ' IN ' denotes a pixel in the INPIX n registers.
INx	The lowercase ' x ' denotes the first input pixel number for the PiCo operation instructions.
INy	The lowercase ' y ' denotes the second input pixel number for the PiCo operation instructions.
INz	The lowercase ' z ' denotes the third input pixel number for the PiCo operation instructions.
OUTd	The uppercase ' OUT ' denotes a pixel in the OUTPIX n registers.
OUTd	The lowercase ' d ' denotes the destination pixel number for the PiCo operation instructions.
Pr	PiCo register. See Section 8.7.1 "Register File" on page 31 for a complete list of registers.
PrHi:PrLo	PiCo register pair. Only register pairs corresponding to valid coprocessor double registers are valid. E.g. INPIX1:INPIX2 (cr1:cr0). The low part must correspond to an even coprocessor register number n and the high part must then correspond to coprocessor register $n+1$. See Table 8-1 on page 31 for a mapping between PiCo register names and coprocessor register numbers.
PC	Program Counter, equal to R15
LR	Link Register, equal to R14
SP	Stack Pointer, equal to R13
PiCoRegList	Register List used in the <i>picoldm</i> and <i>picostm</i> instructions. See instruction description for which register combinations are allowed in the register list.
disp	Displacement
sa	Shift amount
[i]	Denotes bit i in a immediate value. Example: imm6[4] denotes bit 4 in an 6-bit immediate value.
[i:j]	Denotes bit i to j in an immediate value.

Some instructions access or use doubleword operands. These operands must be placed in two consecutive register addresses where the first register must be an even register. The even register contains the least significant part and the odd register contains the most significant part. This ordering is reversed in comparison with how data is organized in memory (where the most significant part would receive the lowest address) and is intentional.

The programmer is responsible for placing these operands in properly aligned register pairs. This is also specified in the "Operands" section in the detailed description of each instruction. Failure to do so will result in an undefined behavior.

8.8.1.2 Operations

ASR(x, n) SE(x, Bits(x) + n) >> n

SATSU(x, n) Signed to Unsigned Saturation (x is treated as a signed value):
If (x > (2ⁿ-1)) then (2ⁿ⁻¹-1); elseif (x < 0) then 0; else x;

SE(x, n) Sign Extend x to an n-bit value

8.8.1.3 Data Type Extensions

.d Double (64-bit) operation.

.w Word (32-bit) operation.

8.8.2 PiCo Instruction Summary

Table 8-4. PiCo instruction summary

Mnemonics		Operands / Syntax	Description	Operation
picosvmac	E	OUTd, INx, INy, INz	PiCo single vector multiplication and accumulation.	See PiCo instruction set reference
picosvmul	E	OUTd, INx, INy, INz	PiCo single vector multiplication	See PiCo instruction set reference
picovmac	E	OUTd, INx, INy, INz	PiCo vector multiplications and accumulations.	See PiCo instruction set reference
picovmul	E	OUTd, INx, INy, INz	PiCo vector multiplications.	See PiCo instruction set reference
picold.d	E	PrHi:PrLo, Rp[disp]	Load PiCo register pair	$PrHi:PrLo \leftarrow *(Rp+ZE(disp8<<2))$
	E	PrHi:PrLo, --Rp	Load PiCo register pair with pre-decrement	$PrHi:PrLo \leftarrow *(--Rp)$
	E	PrHi:PrLo, Rb[Ri<<sa]	Load PiCo register pair with indexed addressing	$PrHi:PrLo \leftarrow *(Rb+(Ri \ll sa2))$
picold.w	E	Pr, Rp[disp]	Load PiCo register	$Pr \leftarrow *(Rp+ZE(disp8<<2))$
	E	Pr, --Rp	Load PiCo register with pre-decrement	$Pr \leftarrow *(--Rp)$
	E	Pr, Rb[Ri<<sa]	Load PiCo register with indexed addressing	$Pr \leftarrow *(Rb+(Ri \ll sa2))$
picoldm	E	Rp{++}, PiCoRegList	Load multiple PiCo registers	See PiCo instruction set reference
picomv.d	E	Rd, PrHi:PrLo	Move from PiCo register pair to CPU register pair	$Rd+1:Rd \leftarrow PrHi:PrLo$
	E	PrHi:PrLo, Rd	Move from CPU register pair to PiCo register pair	$PrHi:PrLo \leftarrow Rd+1:Rd$
picomv.w	E	Rd, Pr	Move from PiCo register to CPU register	$Rd \leftarrow Pr$
	E	Pr, Rd	Move from CPU register to PiCo register	$Pr \leftarrow Rd$
picost.d	E	Rp[disp], PrHi:PrLo	Store PiCo register pair	$*(Rp+ZE(disp8<<2)) \leftarrow PrHi:PrLo$
	E	Rp++, PrHi:PrLo	Store PiCo register pair with post-increment	$*(Rp-) \leftarrow PrHi:PrLo$
	E	Rb[Ri<<sa], PrHi:PrLo	Store PiCo register pair with indexed addressing	$*(Rb+(Ri \ll sa2)) \leftarrow PrHi:PrLo$
picost.w	E	Rp[disp], Pr	Store PiCo register	$*(Rp+ZE(disp8<<2)) \leftarrow Pr$
	E	Rp++, Pr	Store PiCo register with post-increment	$*(Rp-) \leftarrow Pr$
	E	Rb[Ri<<sa], Pr	Store PiCo register with indexed addressing	$*(Rb+(Ri \ll sa2)) \leftarrow Pr$
picostm	E	{--}Rp, PiCoRegList	Store multiple PiCo registers	See PiCo instruction set reference

PICOSVMAC – PiCo Single Vector Multiplication and Accumulation

Description

Performs three vector multiplications where the input pixels taken from the INPIX n registers depends on the Input Selection Mode and the input pixel addresses given in the instruction. The values in the VMU n _OUT registers are then accumulated with the new results from the vector multiplications. The results from each Vector Multiplication Unit (VMU) are then added together for one of the outputs to the Output Pixels Inserter to form the result of a single vector multiplication of two 9-element vectors. The results from the VMUs are then scaled and saturated to unsigned 8-bit values before being inserted into the OUTPIX n registers. Which pixels to update in the OUTPIX n registers depend upon the Output Insertion Mode and the output pixel address given in the instruction.

Operation:

I. if (Input Selection Mode == Horizontal Filter Mode) then

$$VMU0_OUT = [COEFF0_0 \ COEFF0_1 \ COEFF0_2] \begin{bmatrix} IN(x+0) \\ IN(x+1) \\ IN(x+2) \end{bmatrix} + VMU0_OUT$$

$$VMU1_OUT = [COEFF1_0 \ COEFF1_1 \ COEFF1_2] \begin{bmatrix} IN(y+0) \\ IN(y+1) \\ IN(y+2) \end{bmatrix} + VMU1_OUT$$

$$VMU2_OUT = [COEFF2_0 \ COEFF2_1 \ COEFF2_2] \begin{bmatrix} IN(z+0) \\ IN(z+1) \\ IN(z+2) \end{bmatrix} + VMU2_OUT$$

else if (Input Selection Mode == Vertical Filter Mode) then

$$VMU0_OUT = [COEFF0_0 \ COEFF0_1 \ COEFF0_2] \begin{bmatrix} IN((x+0)\%11) \\ IN((x+4)\%11) \\ IN((x+8)\%11) \end{bmatrix} + VMU0_OUT$$

$$VMU1_OUT = [COEFF1_0 \ COEFF1_1 \ COEFF1_2] \begin{bmatrix} IN((y+0)\%11) \\ IN((y+4)\%11) \\ IN((y+8)\%11) \end{bmatrix} + VMU1_OUT$$

$$VMU2_OUT = [COEFF2_0 \ COEFF2_1 \ COEFF2_2] \begin{bmatrix} IN((z+0)\%11) \\ IN((z+4)\%11) \\ IN((z+8)\%11) \end{bmatrix} + VMU2_OUT$$

else if (Input Selection Mode == Transformation Mode) then

$$\begin{bmatrix} VMU0_OUT \\ VMU1_OUT \\ VMU2_OUT \end{bmatrix} = \begin{bmatrix} COEFF0_0 & COEFF0_1 & COEFF0_2 \\ COEFF1_0 & COEFF1_1 & COEFF1_2 \\ COEFF2_0 & COEFF2_1 & COEFF2_2 \end{bmatrix} \begin{bmatrix} INx \\ INy \\ INz \end{bmatrix} + \begin{bmatrix} VMU0_OUT \\ VMU1_OUT \\ VMU2_OUT \end{bmatrix}$$

if (Output Insertion Mode == Packed Insertion Mode) then

OUT(d*3 + 0) ← SATSU(ASR(VMU0_OUT + VMU1_OUT + VMU2_OUT, COEFF_FRAC_BITS), 8);

OUT(d*3 + 1) ← SATSU(ASR(VMU1_OUT, COEFF_FRAC_BITS), 8);

OUT(d*3 + 2) ← SATSU(ASR(VMU2_OUT, COEFF_FRAC_BITS), 8);

else if (Output Insertion Mode == Planar Insertion Mode) then

OUT(d + 0) ← SATSU(ASR(VMU0_OUT + VMU1_OUT + VMU2_OUT, COEFF_FRAC_BITS), 8);

OUT(d + 4) ← SATSU(ASR(VMU1_OUT, COEFF_FRAC_BITS), 8);

OUT(d + 8) ← SATSU(ASR(VMU2_OUT, COEFF_FRAC_BITS), 8);

Syntax:

l. picosvmac OUTd, INx, INy, INz

Operands:

l. d ∈ {0, 1, 2, 3}
x, y, z ∈ {0, 1, ..., 11}

Opcode:

31	30	29	28	27	26	25	24	23	22	21	20	19	18	17	16
1	1	1	0	0	0	0	1	1	0	1	0	0	1	1	OUT d[1]
15	14	13	12	11	10	9	8	7	6	5	4	3	2	1	0
PiCo CP#			OUT d[0]	INx				INy				INz			

Example:

/*

Inner loop of a 16-tap symmetric FIR filter with coefficients {c0, c1, c2, c3, c4, c5, c6, c7, c7, ..., c0} set to filter the pixels pointed to by r12 storing the result to the memory pointed to by r11. The coefficients in the PiCo are already set to the following values: COEFF0_0 = c0, COEFF0_1 = c1, COEFF0_2 = c2, COEFF1_0 = c3, COEFF1_1 = c4, COEFF1_2 = c5, COEFF2_0 = c6, COEFF2_1 = c7, COEFF2_2 = 0, OFFSET0 = 0.5 (For rounding the result), OFFSET1 = 0, OFFSET2 = 0.

The Input Selection Mode is set to Horizontal Filter Mode while the Output Insertion Mode is set to Planar Insertion Mode.

The input image pointer might be unaligned, hence the use of ld.w instead of picold.w.

*/

```

...
ld.w      r1, r12[0]          /* r1 = *((int *)src) */
ld.w      r0, r12[4]          /* r0 = *(((int *)src) + 1) */
ld.w      r2, r12[8]          /* r2 = *(((int *)src) + 2) */
ld.w      r3, r12[12]         /* r3 = *(((int *)src) + 3) */
picomv.d  INPIX1:INPIX2, r0    /* INPIX1={src[0],src[1],src[2],src[3]}, INPIX2={src[4],src[5],src[6],src[7]} */
swap.b    r2                  /* r2 = {src[11],src[10],src[9],src[8]} */
swap.b    r3                  /* r3 = {src[15],src[14],src[13],src[12]} */
picosvmul OUT3, IN4, IN7, IN10 /* VMU0_OUT = c0*src[0]+c1*src[1]+c2*src[2] + 0.5
VMU1_OUT = c3*src[3]+c4*src[4]+c5*src[5]
VMU2_OUT = c6*src[6]+c7*src[7] */
picomv.d  INPIX1:INPIX2, r2    /* INPIX1={src[15],src[14],src[13],src[12]},
INPIX2={src[11],src[10],src[9],src[8]} */
picosvmac OUT3, IN4, IN7, IN10 /* VMU0_OUT += c0*src[15]+c1*src[14]+c2*src[13]
VMU1_OUT += c3*src[12]+c4*src[11]+c5*src[10]
VMU2_OUT += c6*src[9]+c7*src[8]
OUT3 = satscaled(VMU0_OUT+VMU1_OUT+VMU2_OUT) */

sub       r12, -1              /* src++ */
picomv.w  r4, OUTPIX0          /* r4 = { OUT0, OUT1, OUT2, OUT3 }
st.b     r11++, r4            /* *dst = OUT3 */
...

```

PICOSVMUL – PiCo Single Vector Multiplication

Description

Performs three vector multiplications where the input pixels taken from the INPIX n registers depends on the Input Selection Mode and the input pixel addresses given in the instruction. The results from each Vector Multiplication Unit (VMU) are then added together for one of the outputs to the Output Pixels Inserter to form the result of a single vector multiplication of two 9-element vectors. The results from the VMUs are then scaled and saturated to unsigned 8-bit values before being inserted into the OUTPIX n registers. Which pixels to update in the OUTPIX n registers depend upon the Output Insertion Mode and the output pixel address given in the instruction.

Operation:

I. OFFSET_SCALE = COEFF_FRAC_BITS - OFFSET_FRAC_BITS
 if (Input Selection Mode == Horizontal Filter Mode) then

$$VMU0_OUT = \begin{bmatrix} COEFF0_0 & COEFF0_1 & COEFF0_2 \end{bmatrix} \begin{bmatrix} IN(x+0) \\ IN(x+1) \\ IN(x+2) \end{bmatrix} + OFFSET0 \ll OFFSET_SCALE$$

$$VMU1_OUT = \begin{bmatrix} COEFF1_0 & COEFF1_1 & COEFF1_2 \end{bmatrix} \begin{bmatrix} IN(y+0) \\ IN(y+1) \\ IN(y+2) \end{bmatrix} + OFFSET1 \ll OFFSET_SCALE$$

$$VMU2_OUT = \begin{bmatrix} COEFF2_0 & COEFF2_1 & COEFF2_2 \end{bmatrix} \begin{bmatrix} IN(z+0) \\ IN(z+1) \\ IN(z+2) \end{bmatrix} + OFFSET2 \ll OFFSET_SCALE$$

else if (Input Selection Mode == Vertical Filter Mode) then

$$VMU0_OUT = \begin{bmatrix} COEFF0_0 & COEFF0_1 & COEFF0_2 \end{bmatrix} \begin{bmatrix} IN((x+0)\%11) \\ IN((x+4)\%11) \\ IN((x+8)\%11) \end{bmatrix} + OFFSET0 \ll OFFSET_SCALE$$

$$VMU1_OUT = \begin{bmatrix} COEFF1_0 & COEFF1_1 & COEFF1_2 \end{bmatrix} \begin{bmatrix} IN((y+0)\%11) \\ IN((y+4)\%11) \\ IN((y+8)\%11) \end{bmatrix} + OFFSET1 \ll OFFSET_SCALE$$

$$VMU2_OUT = \begin{bmatrix} COEFF2_0 & COEFF2_1 & COEFF2_2 \end{bmatrix} \begin{bmatrix} IN((z+0)\%11) \\ IN((z+4)\%11) \\ IN((z+8)\%11) \end{bmatrix} + OFFSET2 \ll OFFSET_SCALE$$

else if (Input Selection Mode == Transformation Mode) then

$$\begin{bmatrix} VMU0_OUT \\ VMU1_OUT \\ VMU2_OUT \end{bmatrix} = \begin{bmatrix} COEFF0_0 & COEFF0_1 & COEFF0_2 \\ COEFF1_0 & COEFF1_1 & COEFF1_2 \\ COEFF2_0 & COEFF2_1 & COEFF2_2 \end{bmatrix} \begin{bmatrix} INx \\ INy \\ INz \end{bmatrix} + \begin{bmatrix} OFFSET0 \ll OFFSET_SCALE \\ OFFSET1 \ll OFFSET_SCALE \\ OFFSET2 \ll OFFSET_SCALE \end{bmatrix}$$

if (Output Insertion Mode == Packed Insertion Mode) then

OUT(d*3 + 0) ← SATSU(ASR(VMU0_OUT + VMU1_OUT + VMU2_OUT, COEFF_FRAC_BITS), 8);
 OUT(d*3 + 1) ← SATSU(ASR(VMU1_OUT, COEFF_FRAC_BITS), 8);
 OUT(d*3 + 2) ← SATSU(ASR(VMU2_OUT, COEFF_FRAC_BITS), 8);

else if (Output Insertion Mode == Planar Insertion Mode) then

OUT(d + 0) ← SATSU(ASR(VMU0_OUT + VMU1_OUT + VMU2_OUT, COEFF_FRAC_BITS), 8);
 OUT(d + 4) ← SATSU(ASR(VMU1_OUT, COEFF_FRAC_BITS), 8);
 OUT(d + 8) ← SATSU(ASR(VMU2_OUT, COEFF_FRAC_BITS), 8);

Syntax:

l. picosvmul OUTd, INx, INy, INz

Operands:

l. d ∈ {0, 1, 2, 3}
 x, y, z ∈ {0, 1, ..., 11}

Opcode:

31	30	29	28	27	26	25	24	23	22	21	20	19	18	17	16
1	1	1	0	0	0	0	1	1	0	1	0	0	1	0	OUT d[1]
15	14	13	12	11	10	9	8	7	6	5	4	3	2	1	0
PiCo CP#			OUT d[0]	INx				INy				INz			

Example:

/*

Excerpt from inner loop of bilinear interpolation filter operating on image component stored in an array pointed to by r12. The width of the image is stored in r11 while the resulting filtered image is pointed to by r10. The coefficients of the filter: A, B, C, D are already set before this code is executed. COEFF0_0 = A, COEFF0_1 = B, COEFF0_2 = 0, COEFF1_0 = C, COEFF1_1 = D, COEFF1_2 = 0, COEFF2_0 = 0, COEFF2_1 = 0, COEFF2_2 = 0, OFFSET0 = 0.5 (For rounding the result), OFFSET1 = 0, OFFSET2 = 0.

The Input Selection Mode is set to Horizontal Filter Mode while the Output Insertion Mode is set to Planar Insertion Mode.

The input image pointer might be unaligned, hence the use of ld.w instead of picold.w, while the output image pointer is word aligned.

Four output pixels are computed in this example which show an example of a bilinear interpolation filter found in the Motion Compensation used in the H.264 Video Standard.

```

*/
...
ld.w      r1, r12[0]          /* r1 = *((int *)src) */
ld.w      r0, r12[r11]       /* r0 = *((int *)src + width) */
sub       r12, -2           /* src+=2 */
ld.w      r3, r12[0]        /* r3 = *((int *)src) */
ld.w      r2, r12[r11]      /* r2 = *((int *)src + width) */
picomv.d  INPIX1:INPIX2, r0  /* INPIX1 = r1, INPIX2 = r0 */
picosvmul OUT0, IN4, IN8, IN0 /* OUT0 = A*src[j][i+0] + B*src[j][i+1] C*src[j+1][i] + D*src[j+1][i+1] */
picosvmul OUT1, IN5, IN9, IN0 /* OUT1 = A*src[j][i+1] + B*src[j][i+2] C*src[j+1][i+1] + D*src[j+1][i+2] */
picomv.d  INPIX1:INPIX2, r2  /* INPIX1 = r3, INPIX2 = r2 */
picosvmul OUT2, IN4, IN8, IN0 /* OUT2 = A*src[j][i+2] + B*src[j][i+3] C*src[j+1][i+2] + D*src[j+1][i+3] */
picosvmul OUT3, IN5, IN9, IN0 /* OUT3 = A*src[j][i+3] + B*src[j][i+4] C*src[j+1][i+3] + D*src[j+1][i+4] */
sub       r12, -2           /* src+=2 */
picost.w  r10++, OUTPIX0     /* *((int *)src) = { OUT0, OUT1, OUT2, OUT3 } */
...

```



PICOVMAC – PiCo Vector Multiplication and Accumulation

Description

Performs three vector multiplications where the input pixels taken from the INPIX n registers depends on the Input Selection Mode and the input pixel addresses given in the instruction. The values in the VMU n _OUT registers are then accumulated with the new results from the vector multiplications. The results from the VMUs are then scaled and saturated to unsigned 8-bit values before being inserted into the OUTPIX n registers. Which pixels to update in the OUTPIX n registers depend upon the Output Insertion Mode and the output pixel address given in the instruction.

Operation:

I. if (Input Selection Mode == Horizontal Filter Mode) then

$$VMU0_OUT = [COEFF0_0 \ COEFF0_1 \ COEFF0_2] \begin{bmatrix} IN(x+0) \\ IN(x+1) \\ IN(x+2) \end{bmatrix} + VMU0_OUT$$

$$VMU1_OUT = [COEFF1_0 \ COEFF1_1 \ COEFF1_2] \begin{bmatrix} IN(y+0) \\ IN(y+1) \\ IN(y+2) \end{bmatrix} + VMU1_OUT$$

$$VMU2_OUT = [COEFF2_0 \ COEFF2_1 \ COEFF2_2] \begin{bmatrix} IN(z+0) \\ IN(z+1) \\ IN(z+2) \end{bmatrix} + VMU2_OUT$$

else if (Input Selection Mode == Vertical Filter Mode) then

$$VMU0_OUT = [COEFF0_0 \ COEFF0_1 \ COEFF0_2] \begin{bmatrix} IN((x+0)\%11) \\ IN((x+4)\%11) \\ IN((x+8)\%11) \end{bmatrix} + VMU0_OUT$$

$$VMU1_OUT = [COEFF1_0 \ COEFF1_1 \ COEFF1_2] \begin{bmatrix} IN((y+0)\%11) \\ IN((y+4)\%11) \\ IN((y+8)\%11) \end{bmatrix} + VMU1_OUT$$

$$VMU2_OUT = [COEFF2_0 \ COEFF2_1 \ COEFF2_2] \begin{bmatrix} IN((z+0)\%11) \\ IN((z+4)\%11) \\ IN((z+8)\%11) \end{bmatrix} + VMU2_OUT$$

else if (Input Selection Mode == Transformation Mode) then

$$\begin{bmatrix} VMU0_OUT \\ VMU1_OUT \\ VMU2_OUT \end{bmatrix} = \begin{bmatrix} COEFF0_0 & COEFF0_1 & COEFF0_2 \\ COEFF1_0 & COEFF1_1 & COEFF1_2 \\ COEFF2_0 & COEFF2_1 & COEFF2_2 \end{bmatrix} \begin{bmatrix} INx \\ INy \\ INz \end{bmatrix} + \begin{bmatrix} VMU0_OUT \\ VMU1_OUT \\ VMU2_OUT \end{bmatrix}$$

if (Output Insertion Mode == Packed Insertion Mode) then

OUT(d*3 + 0) ← SATSU(ASR(VMU0_OUT, COEFF_FRAC_BITS), 8);
 OUT(d*3 + 1) ← SATSU(ASR(VMU1_OUT, COEFF_FRAC_BITS), 8);
 OUT(d*3 + 2) ← SATSU(ASR(VMU2_OUT, COEFF_FRAC_BITS), 8);

else if (Output Insertion Mode == Planar Insertion Mode) then

OUT(d + 0) ← SATSU(ASR(VMU0_OUT, COEFF_FRAC_BITS), 8);
 OUT(d + 4) ← SATSU(ASR(VMU1_OUT, COEFF_FRAC_BITS), 8);
 OUT(d + 8) ← SATSU(ASR(VMU2_OUT, COEFF_FRAC_BITS), 8);

Syntax:

l. picovmac OUTd, INx, INy, INz

Operands:

l. d ∈ {0, 1, 2, 3}
 x, y, z ∈ {0, 1, ..., 11}

Opcode:

31	30	29	28	27	26	25	24	23	22	21	20	19	18	17	16
1	1	1	0	0	0	0	1	1	0	1	0	0	0	1	OUT d[1]
15	14	13	12	11	10	9	8	7	6	5	4	3	2	1	0
PiCo CP#			OUT d[0]	INx				INy				INz			

Example:

/*

Inner loop of a 6-tap symmetric FIR filter with coefficients {c0, c1, c2, c2, c1, c0} set to filter in the vertical direction of the image pointed to by r12 with the width of the image stored in r11 and the destination image stored in r10. The coefficients in the PiCo are already set to the following values: COEFF0_0 = c0, COEFF0_1 = c1, COEFF0_2 = c2, COEFF1_0 = c0, COEFF1_1 = c1, COEFF1_2 = c2, COEFF2_0 = c0, COEFF2_1 = c1, COEFF2_2 = c2, OFFSET0 = OFFSET1 = OFFSET2 = 0.5 (For rounding the result).

The Input Selection Mode is set to Vertical Filter Mode while the Output Insertion Mode is set to Packed Insertion Mode.

The input image is assumed to be word aligned.

*/

...

```

picold.w      INPIX0, r12[0]          /* INPIX0 = {src[0][0], src[0][1], src[0][2], src[0][3]} */
picold.w      INPIX1, r12[r11]       /* INPIX1 = {src[1][0], src[1][1], src[1][2], src[1][3]} */
picold.w      INPIX2, r12[r11 << 1] /* INPIX2 = {src[2][0], src[2][1], src[2][2], src[2][3]} */
add           r9, r12, r11          /* r9 = src + width */
picovmul      OUT0, IN0, IN1, IN2    /*
                                     VMU0_OUT = c0*src[0][0]+c1*src[1][0]+c2*src[2][0] + 0.5
                                     VMU1_OUT = c0*src[0][1]+c1*src[1][1]+c2*src[2][1] + 0.5
                                     VMU2_OUT = c0*src[0][2]+c1*src[1][2]+c2*src[2][2] + 0.5*/

picold.w      INPIX2, r9[r11 << 1]   /* INPIX2 = {src[3][0], src[3][1], src[3][2], src[3][3]} */
picold.w      INPIX1, r12[r11 << 2]  /* INPIX1 = {src[4][0], src[4][1], src[4][2], src[4][3]} */
picold.w      INPIX0, r9[r11 << 2]   /* INPIX0 = {src[5][0], src[5][1], src[5][2], src[5][3]} */
picovmac      OUT0, IN0, IN1, IN2    /*
                                     VMU0_OUT += c0*src[5][0]+c1*src[4][0]+c2*src[3][0]
                                     VMU1_OUT += c0*src[5][1]+c1*src[4][1]+c2*src[3][1]
                                     VMU2_OUT += c0*src[5][2]+c1*src[4][2]+c2*src[3][2]
                                     OUT0 = satscale(VMU0_OUT), OUT1 = satscale(VMU1_OUT),
                                     OUT2 = satscale(VMU2_OUT) */

```

....



PICOVMUL – PiCo Vector Multiplication

Description

Performs three vector multiplications where the input pixels taken from the INPIX n registers depends on the Input Selection Mode and the input pixel addresses given in the instruction. The results from the VMUs are then scaled and saturated to unsigned 8-bit values before being inserted into the OUTPIX n registers. Which pixels to update in the OUTPIX n registers depend upon the Output Insertion Mode and the output pixel address given in the instruction.

Operation:

- I. OFFSET_SCALE = COEFF_FRAC_BITS - OFFSET_FRAC_BITS
if (Input Selection Mode == Horizontal Filter Mode) then

$$VMU0_OUT = \begin{bmatrix} COEFF0_0 & COEFF0_1 & COEFF0_2 \end{bmatrix} \begin{bmatrix} IN(x+0) \\ IN(x+1) \\ IN(x+2) \end{bmatrix} + OFFSET0 \ll OFFSET_SCALE$$

$$VMU1_OUT = \begin{bmatrix} COEFF1_0 & COEFF1_1 & COEFF1_2 \end{bmatrix} \begin{bmatrix} IN(y+0) \\ IN(y+1) \\ IN(y+2) \end{bmatrix} + OFFSET1 \ll OFFSET_SCALE$$

$$VMU2_OUT = \begin{bmatrix} COEFF2_0 & COEFF2_1 & COEFF2_2 \end{bmatrix} \begin{bmatrix} IN(z+0) \\ IN(z+1) \\ IN(z+2) \end{bmatrix} + OFFSET2 \ll OFFSET_SCALE$$

else if (Input Selection Mode == Vertical Filter Mode) then

$$VMU0_OUT = \begin{bmatrix} COEFF0_0 & COEFF0_1 & COEFF0_2 \end{bmatrix} \begin{bmatrix} IN((x+0)\%11) \\ IN((x+4)\%11) \\ IN((x+8)\%11) \end{bmatrix} + OFFSET0 \ll OFFSET_SCALE$$

$$VMU1_OUT = \begin{bmatrix} COEFF1_0 & COEFF1_1 & COEFF1_2 \end{bmatrix} \begin{bmatrix} IN((y+0)\%11) \\ IN((y+4)\%11) \\ IN((y+8)\%11) \end{bmatrix} + OFFSET1 \ll OFFSET_SCALE$$

$$VMU2_OUT = \begin{bmatrix} COEFF2_0 & COEFF2_1 & COEFF2_2 \end{bmatrix} \begin{bmatrix} IN((z+0)\%11) \\ IN((z+4)\%11) \\ IN((z+8)\%11) \end{bmatrix} + OFFSET2 \ll OFFSET_SCALE$$

else if (Input Selection Mode == Transformation Mode) then

$$\begin{bmatrix} VMU0_OUT \\ VMU1_OUT \\ VMU2_OUT \end{bmatrix} = \begin{bmatrix} COEFF0_0 & COEFF0_1 & COEFF0_2 \\ COEFF1_0 & COEFF1_1 & COEFF1_2 \\ COEFF2_0 & COEFF2_1 & COEFF2_2 \end{bmatrix} \begin{bmatrix} INx \\ INy \\ INz \end{bmatrix} + \begin{bmatrix} OFFSET0 \ll OFFSET_SCALE \\ OFFSET1 \ll OFFSET_SCALE \\ OFFSET2 \ll OFFSET_SCALE \end{bmatrix}$$

if (Output Insertion Mode == Packed Insertion Mode) then

OUT(d*3 + 0) ← SATSU(ASR(VMU0_OUT, COEFF_FRAC_BITS), 8);
OUT(d*3 + 1) ← SATSU(ASR(VMU1_OUT, COEFF_FRAC_BITS), 8);
OUT(d*3 + 2) ← SATSU(ASR(VMU2_OUT, COEFF_FRAC_BITS), 8);

else if (Output Insertion Mode == Planar Insertion Mode) then

OUT(d + 0) ← SATSU(ASR(VMU0_OUT, COEFF_FRAC_BITS), 8);
OUT(d + 4) ← SATSU(ASR(VMU1_OUT, COEFF_FRAC_BITS), 8);
OUT(d + 8) ← SATSU(ASR(VMU2_OUT, COEFF_FRAC_BITS), 8);

Syntax:

l. picovmul OUTd, INx, INy, INz

Operands:

l. $d \in \{0, 1, 2, 3\}$
 $x, y, z \in \{0, 1, \dots, 11\}$

Opcode:

31	30	29	28	27	26	25	24	23	22	21	20	19	18	17	16
1	1	1	0	0	0	0	1	1	0	1	0	0	0	0	OUT d[1]
15	14	13	12	11	10	9	8	7	6	5	4	3	2	1	0
PiCo CP#			OUT d[0]	INx				INy				INz			

Example:

/*

Excerpt from inner loop of YCrCb 4:2:2 planar format to RGB packed format image color conversion. The coefficients of the transform is already set before this code is executed. In transforms like this, the inputs Y, Cr and Cb are often offsetted with a given amount. This offset can be factored out and included in the offsets like this:
 $1.164*(Y - 16) = 1.164*Y - 18.625$.

The pointer to the Y component is in r12, the pointer to the Cr component in r11 and the pointer to the Cb component in r10. The pointer to the RGB output image is in r9.

The Input Selection Mode is set to Transform Mode while the Output Insertion Mode is set to Packed Insertion Mode.

It is assumed that all the input and output pointers are word aligned.

Four RGB triplets are computed in this example. */

```

...
picold.w      INPIX0, r12++      /* INPIX0= { Y[0], Y[1], Y[2], Y[3] }*/
picold.w      INPIX1, r11++      /* INPIX1= { Cr[0], Cr[1], Cr[2], Cr[3] }*/
picold.w      INPIX2, r10++      /* INPIX2= { Cb[0], Cb[1], Cb[2], Cb[3] }*/
picovmul      OUT0, IN0, IN4, IN8 /* OUT0 = r[0], OUT1 = g[0], OUT2 = b[0] */
picovmul      OUT1, IN1, IN4, IN8 /* OUT3 = r[1], OUT4 = g[1], OUT5 = b[1] */
picovmul      OUT2, IN2, IN5, IN9 /* OUT6 = r[2], OUT7 = g[2], OUT8 = b[2] */
picovmul      OUT3, IN3, IN5, IN9 /* OUT9 = r[3], OUT10 = g[3], OUT11 = b[3] */
picostm       r9, OUTPIX2, OUTPIX1, OUTPIX0/* RGB = {r[0],g[0],b[0],r[1],g[1],b[1],r[2],g[2],b[2],r[3],g[3],b[3]} */
...

```



PICOLD.{D,W} – Load PiCo Register(s)

Description

Reads the memory location specified into the given coprocessor register(s).

Operation:

- I. PrHi:PrLo \leftarrow *(Rp + (ZE(disps8) << 2));
- II. Rp \leftarrow Rp-8;
PrHi:PrLo \leftarrow *(Rp);
- III. PrHi:PrLo \leftarrow *(Rb + (Ri << sa2));
- IV. Pr \leftarrow *(Rp + (ZE(disps8) << 2));
- V. Rp \leftarrow Rp-4;
Pr \leftarrow *(Rp);
- VI. Pr \leftarrow *(Rb + (Ri << sa2));

Syntax:

- I. picold.d PrHi:PrLo, Rp[disp]
- II. picold.d PrHi:PrLo, --Rp
- III. picold.d PrHi:PrLo, Rb[Ri<<sa]
- IV. picold.w Pr, Rp[disp]
- V. picold.w Pr, --Rp
- VI. picold.w Pr, Rb[Ri<<sa]

Operands:

- I-III. PrHi:PrLo \in { INPIX1:INPIX2, COEFF0_B:COEFF0_A, COEFF1_B:COEFF1_A, COEFF2_B:COEFF2_A, VMU1_OUT:VMU0_OUT, CONFIG:VMU2_OUT }
- IV-VI. Pr \in { INPIX0, INPIX1, INPIX2, COEFF0_A, COEFF0_B, COEFF1_A, COEFF1_B, COEFF2_A, COEFF2_B, VMU0_OUT, VMU1_OUT, VMU2_OUT, CONFIG }
- I-II, IV-V.p \in {0, 1, ..., 15}
- I, IV. disp \in {0, 4, ..., 1020}
- III, VI. {b, i} \in {0, 1, ..., 15}
- III, VI. sa \in {0, 1, 2, 3}

Opcode

I.

31	30	29	28	27	26	25	24	23	22	21	20	19	18	17	16
1	1	1	0	1	0	0	1	1	0	1	0	Rp			
15	14	13	12	11	10	9	8	7	6	5	4	3	2	1	0
PiCo CP#			1	PrLo[3:1]			0	disp8							

II.

31	30	29	28	27	26	25	24	23	22	21	20	19	18	17	16	
1	1	1	0	1	1	1	1	1	0	1	0	Rp				
15	14	13	12	11	10	9	8	7	6	5	4	3	2	1	0	
PiCo CP#			0	PrLo[3:1]			0	0	1	0	1	0	0	0	0	0

III.

31	30	29	28	27	26	25	24	23	22	21	20	19	18	17	16
1	1	1	0	1	1	1	1	1	0	1	0	Rp			
15	14	13	12	11	10	9	8	7	6	5	4	3	2	1	0
PiCo CP#			1	PrLo[3:1]			0	0	1	Shamt		Ri			

IV.

31	30	29	28	27	26	25	24	23	22	21	20	19	18	17	16
1	1	1	0	1	0	0	1	1	0	1	0	Rp			
15	14	13	12	11	10	9	8	7	6	5	4	3	2	1	0
PiCo CP#		0	Pr				disp8								

V.

31	30	29	28	27	26	25	24	23	22	21	20	19	18	17	16
1	1	1	0	1	1	1	1	1	0	1	0	Rp			
15	14	13	12	11	10	9	8	7	6	5	4	3	2	1	0
PiCo CP#		0	Pr				0	1	0	0	0 0 0 0				

VI.

31	30	29	28	27	26	25	24	23	22	21	20	19	18	17	16
1	1	1	0	1	1	1	1	1	0	1	0	Rp			
15	14	13	12	11	10	9	8	7	6	5	4	3	2	1	0
PiCo CP#		1	Pr				0	0	Shamt		Ri				

Example:

picold.d COEFF0_B:COEFF0_A, r12[4]

PICOLDM – Load Multiple PiCo Registers

Description

Reads the memory locations specified into the given PiCo registers. The pointer register can optionally be updated after the operation.

Operation:

```
I. II. III. Loadaddress ←Rp;
    if ( PiCoRegList contains CONFIG )
        CONFIG ← *(Loadaddress++);
    if ( PiCoRegList contains VMU2_OUT )
        VMU2_OUT ← *(Loadaddress++);
    if ( PiCoRegList contains VMU1_OUT )
        VMU1_OUT ← *(Loadaddress++);
    if ( PiCoRegList contains VMU0_OUT )
        VMU0_OUT ← *(Loadaddress++);
    if ( PiCoRegList contains COEFF2_B )
        COEFF2_B ← *(Loadaddress++);
    if ( PiCoRegList contains COEFF2_A )
        COEFF2_A ← *(Loadaddress++);
    if ( PiCoRegList contains COEFF1_B )
        COEFF1_B ← *(Loadaddress++);
    if ( PiCoRegList contains COEFF1_A )
        COEFF1_A ← *(Loadaddress++);
    if ( PiCoRegList contains COEFF0_B )
        COEFF0_B ← *(Loadaddress++);
    if ( PiCoRegList contains COEFF0_A )
        COEFF0_A ← *(Loadaddress++);
    if ( PiCoRegList contains OUTPIX0 )
        Loadaddress++;
    if ( PiCoRegList contains OUTPIX1 )
        Loadaddress++;
    if ( PiCoRegList contains OUTPIX2 )
        Loadaddress++;
    if ( PiCoRegList contains INPIX0 )
        INPIX0 ← *(Loadaddress++);
    if ( PiCoRegList contains INPIX1 )
        INPIX1 ← *(Loadaddress++);
    if ( PiCoRegList contains INPIX2 )
        INPIX2 ← *(Loadaddress++);

    if Opcode[++] == 1 then
        Rp ← Loadaddress;
```

Syntax:

```
I.    picoldm    Rp{++}, PiCoRegList
II.   picoldm    Rp{++}, PiCoRegList
III.  picoldm    Rp{++}, PiCoRegList
```

Operands:

```
I.    PiCoRegList ∈ { {INPIX1, INPIX2}, {OUTPIX2, INPIX0}, {OUTPIX0, OUTPIX1}, {COEFF0_B, COEFF0_A},
                    {COEFF1_B, COEFF1_A}, {COEFF2_B, COEFF2_A}, {VMU1_OUT, VMU0_OUT},
```

{CONFIG, VMU2_OUT }

- II. PiCoRegList ∈ { INPIX0, INPIX1, INPIX2, OUTPIX0, OUTPIX1, OUTPIX2, COEFF0_A, COEFF0_B }
- III. PiCoRegList ∈ { COEFF1_A, COEFF1_B, COEFF2_A, COEFF2_B, VMU0_OUT, VMU1_OUT, VMU2_OUT, CONFIG, }
- I-III. p ∈ {0, 1, ..., 15}

Opcode

I.

31	30	29	28	27	26	25	24	23	22	21	20	19	18	17	16
1	1	1	0	1	1	0	1	1	0	1	0	Rp			
15	14	13	12	11	10	9	8	7	6	5	4	3	2	1	0
PiCo CP#	W	0	1	0	0	CONFIG VMU2_OUT	VMU1_OUT VMU0_OUT	COEFF2_B COEFF2_A	COEFF1_B COEFF1_A	COEFF0_B COEFF0_A	OUTPIX0 OUTPIX1	OUTPIX2 INPIX0	INPIX1 INPIX2		

II.

31	30	29	28	27	26	25	24	23	22	21	20	19	18	17	16
1	1	1	0	1	1	0	1	1	0	1	0	Rp			
15	14	13	12	11	10	9	8	7	6	5	4	3	2	1	0
PiCo CP#	W	0	0	0	0	COEFF0_B	COEFF0_A	OUTPIX0	OUTPIX1	OUTPIX2	INPIX0	INPIX1	INPIX2		

III.

31	30	29	28	27	26	25	24	23	22	21	20	19	18	17	16
1	1	1	0	1	1	0	1	1	0	1	0	Rp			
15	14	13	12	11	10	9	8	7	6	5	4	3	2	1	0
PiCo CP#	W	0	0	0	1	CONFIG	VMU2_OUT	VMU1_OUT	VMU0_OUT	COEFF2_B	COEFF2_A	COEFF1_B	COEFF1_A		

Example:

- I. picoldm r7++, COEFF0_A, COEFF0_B, COEFF1_A, COEFF1_B, COEFF2_A, COEFF2_B
- II. picoldm r0, INPIX0, INPIX1, INPIX2
- III. picoldm r12, VMU0_OUT, VMU1_OUT, VMU2_OUT

PICOMV.{D,W} – Move between PiCo Register(s) and Register File

Description

Move the specified PiCo register(s) to register(s) in the Register File or move register(s) in the Register File to PiCo register(s).

Operation:

- I. PrHi:PrLo \leftarrow (Rs+1:Rs);
- II. Pr \leftarrow Rs;
- III. (Rd+1:Rd) \leftarrow PrHi:PrLo;
- IV. Rd \leftarrow Pr;

Syntax:

- I. picomv.d PrHi:PrLo, Rs
- II. picomv.w Pr, Rs
- III. picomv.d Rd, PrHi:PrLo
- IV. picomv.w Rd, Pr

Operands:

- I, II. PrHi:PrLo \in { INPIX1:INPIX2, OUTPIX2:INPIX0, OUTPIX0:OUTPIX1, COEFF0_B:COEFF0_A, COEFF1_B:COEFF1_A, COEFF2_B:COEFF2_A, VMU1_OUT:VMU0_OUT, CONFIG:VMU2_OUT }
- II, IV. Pr \in { INPIX0, INPIX1, INPIX2, OUTPIX0, OUTPIX1, OUTPIX2, COEFF0_A, COEFF0_B, COEFF1_A, COEFF1_B, COEFF2_A, COEFF2_B, VMU0_OUT, VMU1_OUT, VMU2_OUT, CONFIG }
- I. s \in {0, 2, 4, ..., 14}
- III. d \in {0, 2, 4, ..., 14}
- II. s \in {0, 1, ..., 15}
- IV. d \in {0, 1, ..., 15}

Opcode

I.

31	30	29	28	27	26	25	24	23	22	21	20	19	18	17	16
1	1	1	0	1	1	1	1	1	0	1	0		Rs		0
15	14	13	12	11	10	9	8	7	6	5	4	3	2	1	0
PiCo CP#			0	PrLo[3:1]			0	0	0	1	1	0	0	0	0

II.

31	30	29	28	27	26	25	24	23	22	21	20	19	18	17	16
1	1	1	0	1	1	1	1	1	0	1	0		Rs		
15	14	13	12	11	10	9	8	7	6	5	4	3	2	1	0
PiCo CP#			0	Pr			0	0	1	0	0	0	0	0	0

III.

31	30	29	28	27	26	25	24	23	22	21	20	19	18	17	16
1	1	1	0	1	1	1	1	1	0	1	0	Rd			0
15	14	13	12	11	10	9	8	7	6	5	4	3	2	1	0
PiCo CP#			0	PrLo[3:1]			0	0	0	0	1	0	0	0	0

IV.

31	30	29	28	27	26	25	24	23	22	21	20	19	18	17	16
1	1	1	0	1	1	1	1	1	0	1	0	Rd			0
15	14	13	12	11	10	9	8	7	6	5	4	3	2	1	0
PiCo CP#			0	Pr			0	0	0	0	0	0	0	0	0

Example:

```

picomv.d    r2, OUTPIX0:OUTPIX1
picomv.w    CONFIG, lr
    
```

PICOST.{D,W} – Store PiCo Register(s)

Description

Stores the PiCo register value(s) to the memory location specified by the addressing mode.

Operation:

- I. $*(Rp + (ZE(dispatch) \ll 2)) \leftarrow PrHi:PrLo;$
- II. $*(Rp) \leftarrow PrHi:PrLo;$
 $Rp \leftarrow Rp+8;$
- III. $*(Rb + (Ri \ll sa2)) \leftarrow PrHi:PrLo;$
- IV. $*(Rp + (ZE(dispatch) \ll 2)) \leftarrow Pr;$
- V. $*(Rp) \leftarrow Pr;$
 $Rp \leftarrow Rp-4;$
- VI. $*(Rb + (Ri \ll sa2)) \leftarrow Pr;$

Syntax:

- I. picost.d Rp[disp], PrHi:PrLo
- II. picost.d Rp++, PrHi:PrLo
- III. picost.d Rb[Ri<<sa], PrHi:PrLo
- IV. picost.w Rp[disp], Pr
- V. picost.w Rp++, Pr
- VI. picost.w Rb[Ri<<sa], Pr

Operands:

- I-III. PrHi:PrLo $\in \{$ INPIX1:INPIX2, OUTPIX2:INPIX0, OUTPIX0:OUTPIX1, COEFF0_B:COEFF0_A, COEFF1_B:COEFF1_A, COEFF2_B:COEFF2_A, VMU1_OUT:VMU0_OUT, CONFIG:VMU2_OUT $\}$
- IV-VI. Pr $\in \{$ INPIX0, INPIX1, INPIX2, OUTPIX0, OUTPIX1, OUTPIX2, COEFF0_A, COEFF0_B, COEFF1_A, COEFF1_B, COEFF2_A, COEFF2_B, VMU0_OUT, VMU1_OUT, VMU2_OUT, CONFIG $\}$
- I-II, IV-V.p $\in \{0, 1, \dots, 15\}$
- I, IV. disp $\in \{0, 4, \dots, 1020\}$
- III, VI. {b, i} $\in \{0, 1, \dots, 15\}$
- III, VI. sa $\in \{0, 1, 2, 3\}$

Opcode

I.

31	30	29	28	27	26	25	24	23	22	21	20	19	18	17	16
1	1	1	0	1	0	1	1	1	0	1	0	Rp			
15	14	13	12	11	10	9	8	7	6	5	4	3	2	1	0
PiCo CP#			1	PrLo[3:1]			0	disp8							

II.

31	30	29	28	27	26	25	24	23	22	21	20	19	18	17	16
1	1	1	0	1	1	1	1	1	0	1	0	Rp			
15	14	13	12	11	10	9	8	7	6	5	4	3	2	1	0
PiCo CP#			0	PrLo[3:1]			0	0	1	1	1	0	0	0	0

III.

31	30	29	28	27	26	25	24	23	22	21	20	19	18	17	16
1	1	1	0	1	1	1	1	1	0	1	0	Rp			
15	14	13	12	11	10	9	8	7	6	5	4	3	2	1	0
PiCo CP#			1	PrLo[3:1]			0	1	1	Shamt		Ri			

IV.

31	30	29	28	27	26	25	24	23	22	21	20	19	18	17	16
1	1	1	0	1	0	1	1	1	0	1	0	Rp			
15	14	13	12	11	10	9	8	7	6	5	4	3	2	1	0
PiCo CP#		0	Pr				disp8								

V.

31	30	29	28	27	26	25	24	23	22	21	20	19	18	17	16
1	1	1	0	1	1	1	1	1	0	1	0	Rp			
15	14	13	12	11	10	9	8	7	6	5	4	3	2	1	0
PiCo CP#		0	Pr				0	1	1	0	0 0 0 0				

VI.

31	30	29	28	27	26	25	24	23	22	21	20	19	18	17	16
1	1	1	0	1	1	1	1	1	0	1	0	Rp			
15	14	13	12	11	10	9	8	7	6	5	4	3	2	1	0
PiCo CP#		1	Pr				1	0	Shamt		Ri				

Example:

picost.w

r10++, OUTPIX0

PICOSTM – Store Multiple PiCo Registers

Description

Writes the PiCo registers specified in the register list into the specified memory locations.

Operation:

I. II. III.

```

if Opcode[--] == 1 then
    Rp ← Rp - 4*RegistersInList;
Storeaddress ←Rp;

if ( PiCoRegList contains CONFIG )
    *(Storeaddress++) ← CONFIG;
if ( PiCoRegList contains VMU2_OUT )
    *(Storeaddress++) ← VMU2_OUT;
if ( PiCoRegList contains VMU1_OUT )
    *(Storeaddress++) ← VMU1_OUT;
if ( PiCoRegList contains VMU0_OUT )
    *(Storeaddress++) ← VMU0_OUT;
if ( PiCoRegList contains COEFF2_B )
    *(Storeaddress++) ← COEFF2_B;
if ( PiCoRegList contains COEFF2_A )
    *(Storeaddress++) ← COEFF2_A;
if ( PiCoRegList contains COEFF1_B )
    *(Storeaddress++) ← COEFF1_B;
if ( PiCoRegList contains COEFF1_A )
    *(Storeaddress++) ← COEFF1_A;
if ( PiCoRegList contains COEFF0_B )
    *(Storeaddress++) ← COEFF0_B;
if ( PiCoRegList contains COEFF0_A )
    *(Storeaddress++) ← COEFF0_A;
if ( PiCoRegList contains OUTPIX0 )
    *(Storeaddress++) ← OUTPIX0;
if ( PiCoRegList contains OUTPIX1 )
    *(Storeaddress++) ← OUTPIX1;
if ( PiCoRegList contains OUTPIX2 )
    *(Storeaddress++) ← OUTPIX2;
if ( PiCoRegList contains INPIX0 )
    *(Storeaddress++) ←INPIX0 ;
if ( PiCoRegList contains INPIX1 )
    *(Storeaddress++) ←INPIX1 ;
if ( PiCoRegList contains INPIX2 )
    *(Storeaddress++) ←INPIX2 ;
    
```

Syntax:

```

I.    picostm    {--}Rp, PiCoRegList
II.   picostm    {--}Rp, PiCoRegList
III.  picostm    {--}Rp, PiCoRegList
    
```

Operands:

I. PiCoRegList ∈ { {INPIX1, INPIX2}, {OUTPIX2, INPIX0}, {OUTPIX0, OUTPIX1}, {COEFF0_B, COEFF0_A}, {COEFF1_B, COEFF1_A}, {COEFF2_B, COEFF2_A}, {VMU1_OUT, VMU0_OUT},

{CONFIG, VMU2_OUT }

- II. PiCoRegList ∈ { INPIX0, INPIX1, INPIX2, OUTPIX0, OUTPIX1, OUTPIX2, COEFF0_A, COEFF0_B }
- III. PiCoRegList ∈ { COEFF1_A, COEFF1_B, COEFF2_A, COEFF2_B, VMU0_OUT, VMU1_OUT, VMU2_OUT, CONFIG, }
- I-III. p ∈ {0, 1, ..., 15}

Opcode

I.

31	30	29	28	27	26	25	24	23	22	21	20	19	18	17	16
1	1	1	0	1	1	0	1	1	0	1	0	Rp			
15	14	13	12	11	10	9	8	7	6	5	4	3	2	1	0
PiCo CP#	W	0	1	0	1	CONFIG VMU2_OUT	VMU1_OUT VMU0_OUT	COEFF2_B COEFF2_A	COEFF1_B COEFF1_A	COEFF0_B COEFF0_A	OUTPIX0 OUTPIX1	OUTPIX2 INPIX0	INPIX1 INPIX2		

II.

31	30	29	28	27	26	25	24	23	22	21	20	19	18	17	16
1	1	1	0	1	1	0	1	1	0	1	0	Rp			
15	14	13	12	11	10	9	8	7	6	5	4	3	2	1	0
PiCo CP#	W	0	0	1	0	COEFF0_B	COEFF0_A	OUTPIX0	OUTPIX1	OUTPIX2	INPIX0	INPIX1	INPIX2		

III.

31	30	29	28	27	26	25	24	23	22	21	20	19	18	17	16
1	1	1	0	1	1	0	1	1	0	1	0	Rp			
15	14	13	12	11	10	9	8	7	6	5	4	3	2	1	0
PiCo CP#	W	0	0	1	1	CONFIG	VMU2_OUT	VMU1_OUT	VMU0_OUT	COEFF2_B	COEFF2_A	COEFF1_B	COEFF1_A		

Example:

- I. picostm --r7, COEFF0_A, COEFF0_B, COEFF1_A, COEFF1_B, COEFF2_A, COEFF2_B
- II. picostm r2, OUTPIX0, OUTPIX1, OUTPIX2
- III. picostm r11, VMU0_OUT, VMU1_OUT, VMU2_OUT

8.9 Data Hazards

Data hazards are caused by data dependencies between instructions which are in different stages of the pipeline and reads/writes registers which are common to several pipeline stages. Because of the 3-stage pipeline employed in the PiCo data hazards might exist between instructions. Data hazards are handled by hardware interlocks which can stall a new read command from or write command to the PiCo register file.

Table 8-5. Data Hazards

Instruction	Next Instruction	Condition	Stall Cycles
picovmul picovmac picosvmul picosvmac	picomv.x Pr,... picold.x picoldm	Write-After-Read (WAR) or Write-After-Write (WAW) Hazard will occur if writing COEFF _n _A/B, VMU _n _OUT or CONFIG since these are accessed when the PiCo command is in Pipeline Stage 2 and Pipeline Stage 3.	1
		Writes to INPIX _n registers produces no hazard since they are only accessed in Pipeline Stage 1.	0
	picomv.x Rd,... picost.x picostm	Read-After-Write Hazard (RAW) will occur if reading the PiCo register file while a command is in the pipeline.	2

9. Memories

9.1 Embedded Memories

- 32 Kbyte SRAM
 - Implemented as two 16Kbyte blocks
 - Single cycle access at full bus speed

9.2 Physical Memory Map

The system bus is implemented as an HSB bus matrix. All system bus addresses are fixed, and they are never remapped in any way, not even in boot. Note that AT32AP7001 by default uses segment translation, as described in the AVR32 Architecture Manual. The 32 bit physical address space is mapped as follows:

Table 9-1. AT32AP7001 Physical Memory Map

Start Address	Size	Device
0x0000_0000	64 Mbyte	EBI SRAM CS0
0x0400_0000	64 Mbyte	EBI SRAM CS4
0x0800_0000	64 Mbyte	EBI SRAM CS2
0x0C00_0000	64 Mbyte	EBI SRAM CS3
0x1000_0000	256 Mbyte	EBI SRAM/SDRAM CS1
0x2000_0000	64 Mbyte	EBI SRAM CS5
0x2400_0000	16 Kbyte	Internal SRAM 0
0x2400_4000	16 Kbyte	Internal SRAM1
0xFF00_0000	4 Kbyte	LCDC configuration
0xFF20_0000	1 KByte	DMAC configuration
0xFF30_0000	1 MByte	USB Data
0xFFE0_0000	1 MByte	PBA
0xFFFF0_0000	1 MByte	PBB

Accesses to unused areas returns an error result to the master requesting such an access.

The bus matrix has the several masters and slaves. Each master has its own bus and its own decoder, thus allowing a different memory mapping per master. The master number in the table below can be used to index the HMATRIX control registers. For example, MCFG2 is associated with the HSB-HSB bridge.

Table 9-2. HSB masters

Master 0	CPU Dcache
Master 1	CPU Icache
Master 2	HSB-HSB Bridge
Master 3	ISI DMA
Master 4	USB DMA
Master 5	LCD Controller DMA
Master 6	Ethernet MAC0 DMA
Master 7	Ethernet MAC1 DMA
Master 8	DMAC Master Interface 0
Master 9	DMAC Master Interface 1

Each slave has its own arbiter, thus allowing a different arbitration per slave. The slave number in the table below can be used to index the HMATRIX control registers. For example, SCFG3 is associated with PBB.

Table 9-3. HSB slaves

Slave 0	Internal SRAM 0
Slave 1	Internal SRAM1
Slave 2	PBA
Slave 3	PBB
Slave 4	EBI
Slave 5	USB data
Slave 6	LCDC configuration
Slave 7	DMAC configuration

10. Peripherals

10.1 Peripheral address map

Table 10-1. Peripheral Address Mapping

Address		Peripheral Name	Bus
0xFF200000	DMAC	DMA Controller Slave Interface- DMAC	HSB
0xFF300000	USB	USB 2.0 Slave Interface - USB	HSB
0xFFE00000	SPI0	Serial Peripheral Interface - SPI0	PB A
0xFFE00400	SPI1	Serial Peripheral Interface - SPI1	PB A
0xFFE00800	TWI	Two-wire Interface - TWI	PB A
0xFFE00C00	USART0	Universal Synchronous Asynchronous Receiver Transmitter - USART0	PB A
0xFFE01000	USART1	Universal Synchronous Asynchronous Receiver Transmitter - USART1	PB A
0xFFE01400	USART2	Universal Synchronous Asynchronous Receiver Transmitter - USART2	PB A
0xFFE01800	USART3	Universal Synchronous Asynchronous Receiver Transmitter - USART3	PB A
0xFFE01C00	SSC0	Synchronous Serial Controller - SSC0	PB A
0xFFE02000	SSC1	Synchronous Serial Controller - SSC1	PB A
0xFFE02400	SSC2	Synchronous Serial Controller - SSC2	PB A
0xFFE02800	PIOA	Parallel Input/Output 2 - PIOA	PB A
0xFFE02C00	PIOB	Parallel Input/Output 2 - PIOB	PB A
0xFFE03000	PIOC	Parallel Input/Output 2 - PIOC	PB A
0xFFE03400	PIOD	Parallel Input/Output 2 - PIOD	PB A
0xFFE03800	PIOE	Parallel Input/Output 2 - PIOE	PB A

Table 10-1. Peripheral Address Mapping (Continued)

Address	Peripheral Name	Bus
0xFFE03C00	PSIF PS2 Interface - PSIF	PB A
0xFFFF0000	SM System Manager - SM	PB B
0xFFFF00400	INTC Interrupt Controller - INTC	PB B
0xFFFF00800	HMATRIX HSB Matrix - HMATRIX	PB B
0xFFFF00C00	TC0 Timer/Counter - TC0	PB B
0xFFFF01000	TC1 Timer/Counter - TC1	PB B
0xFFFF01400	PWM Pulse Width Modulation Controller - PWM	PB B
0xFFFF02000	DAC DAC - Audio DAC	PB B
0xFFFF02400	MCI Multimedia Card Interface - MCI	PB B
0xFFFF02800	AC97C AC97 Controller - AC97C	PB B
0xFFFF02C00	ISI Image Sensor Interface - ISI	PB B
0xFFFF03000	USB USB 2.0 Configuration Interface - USB	PB B
0xFFFF03400	SMC Static Memory Controller - SMC	PB B
0xFFFF03800	SDRAMC SDRAM Controller - SDRAMC	PB B
0xFFFF03C00	ECC Error Correcting Code Controller - ECC	PB B

10.2 Interrupt Request Signal Map

The various modules may output interrupt request signals. These signals are routed to the Interrupt Controller (INTC). The Interrupt Controller supports up to 64 groups of interrupt requests. Each group can have up to 32 interrupt request signals. All interrupt signals in the same group share the same autovector address and priority level. Refer to the documentation for the individual submodules for a description of the semantic of the different interrupt requests.

The interrupt request signals in AT32AP7001 are connected to the INTC as follows:

Table 10-2. Interrupt Request Signal Map

Group	Line	Signal
0	0	COUNT-COMPARE match
	1	Performance Counter Overflow
2	0	DMAC BLOCK
	1	DMAC DSTT
	2	DMAC ERR
	3	DMAC SRCT
	4	DMAC TFR
3	0	SPI 0
4	0	SPI 1
5	0	TWI
6	0	USART0
7	0	USART1
8	0	USART2
9	0	USART3
10	0	SSC0
11	0	SSC1
12	0	SSC2
13	0	PIOA
14	0	PIOB
15	0	PIOC
16	0	PIOD
17	0	PIOE
18	0	PSIF
19	0	EIM0
	1	EIM1
	2	EIM2
	3	EIM3
20	0	PM
21	0	RTC
22	0	TC00
	1	TC01
	2	TC02
23	0	TC10
	1	TC11
	2	TC12

Table 10-2. Interrupt Request Signal Map

Group	Line	Signal
24	0	PWM
27	0	DAC
28	0	MCI
29	0	AC97C
30	0	ISI
31	0	USB
32	0	EBI

10.3 DMAC Handshake Interface Map

The following table details the hardware handshake map between the DMAC and the peripherals attached to it :

Table 10-3. Hardware Handshaking Connection

Request	Hardware Handshaking Interface
MCI RX	0
MCI TX	1
DAC TX	2
AC97C CHANNEL A RX	3
AC97C CHANNEL A TX	4
AC97C CHANNEL B RX	5
AC97C CHANNEL B TX	6
EXTERNAL DMA REQUEST 0	7
EXTERNAL DMA REQUEST 1	8
EXTERNAL DMA REQUEST 2	9
EXTERNAL DMA REQUEST 3	10

10.4 Clock Connections

10.4.1 Timer/Counters

Each Timer/Counter channel can independently select an internal or external clock source for its counter:

Table 10-4. Timer/Counter clock connections

Timer/Counter	Source	Name	Connection
0	Internal	TIMER_CLOCK1	clk_slow
		TIMER_CLOCK2	clk_pbb / 4
		TIMER_CLOCK3	clk_pbb / 8
		TIMER_CLOCK4	clk_pbb / 16
		TIMER_CLOCK5	clk_pbb / 32
	External	XC0	See Section 10.7
		XC1	
		XC2	
1	Internal	TIMER_CLOCK1	clk_slow
		TIMER_CLOCK2	clk_pbb / 4
		TIMER_CLOCK3	clk_pbb / 8
		TIMER_CLOCK4	clk_pbb / 16
		TIMER_CLOCK5	clk_pbb / 32
	External	XC0	See Section 10.7
		XC1	
		XC2	

10.4.2 USARTs

Each USART can be connected to an internally divided clock:

Table 10-5. USART clock connections

USART	Source	Name	Connection
0	Internal	CLK_DIV	clk_pba / 8
1			
2			
3			

10.4.3 SPIs

Each SPI can be connected to an internally divided clock:

Table 10-6. SPI clock connections

SPI	Source	Name	Connection
0	Internal	CLK_DIV	clk_pba / 32
1			

10.5 External Interrupt Pin Mapping

External interrupt requests are connected to the following pins::

Table 10-7. External Interrupt Pin Mapping

Source	Connection
NMI_N	PB24
EXTINT0	PB25
EXTINT1	PB26
EXTINT2	PB27
EXTINT3	PB28

10.6 Nexus OCD AUX port connections

If the OCD trace system is enabled, the trace system will take control over a number of pins, irrespectively of the PIO configuration. Two different OCD trace pin mappings are possible, depending on the configuration of the OCD AXS register. For details, see the *AVR32 AP Technical Reference Manual*.

Table 10-8. Nexus OCD AUX port connections

Pin	AXS=0	AXS=1
EVTI_N	EVTI_N	EVTI_N
MDO[5]	PB09	PC18
MDO[4]	PB08	PC14
MDO[3]	PB07	PC12
MDO[2]	PB06	PC11
MDO[1]	PB05	PC06
MDO[0]	PB04	PC05
EVTO_N	PB03	PB28
MCKO	PB02	PC02
MSEO[1]	PB01	PC01
MSEO[0]	PB00	PC00

10.7 Peripheral Multiplexing on IO lines

The AT32AP7001 features five PIO controllers, PIOA to PIOE, that multiplex the I/O lines of the peripheral set. Each PIO Controller controls up to thirty-two lines.

Each line can be assigned to one of two peripheral functions, A or B. The tables in the following pages define how the I/O lines of the peripherals A and B are multiplexed on the PIO Controllers.

Note that some output only peripheral functions might be duplicated within the tables.

10.7.1 PIO Controller A Multiplexing

Table 10-9. PIO Controller A Multiplexing

I/O Line	Peripheral A	Peripheral B
PA00	SPI0 - MISO	SSC1 - RX_FRAME_SYNC
PA01	SPI0 - MOSI	SSC1 - TX_FRAME_SYNC
PA02	SPI0 - SCK	SSC1 - TX_CLOCK
PA03	SPI0 - NPCS[0]	SSC1 - RX_CLOCK
PA04	SPI0 - NPCS[1]	SSC1 - TX_DATA
PA05	SPI0 - NPCS[2]	SSC1 - RX_DATA
PA06	TWI - SDA	USART0 - RTS
PA07	TWI - SCL	USART0 - CTS
PA08	PSIF - CLOCK	USART0 - RXD
PA09	PSIF - DATA	USART0 - TXD
PA10	MCI - CLK	USART0 - CLK
PA11	MCI - CMD	TC0 - CLK0
PA12	MCI - DATA[0]	TC0 - A0
PA13	MCI - DATA[1]	TC0 - A1
PA14	MCI - DATA[2]	TC0 - A2
PA15	MCI - DATA[3]	TC0 - B0
PA16	USART1 - CLK	TC0 - B1
PA17	USART1 - RXD	TC0 - B2
PA18	USART1 - TXD	TC0 - CLK2
PA19	USART1 - RTS	TC0 - CLK1
PA20	USART1 - CTS	SPI0 - NPCS[3]
PA21	SSC0 - RX_FRAME_SYNC	PWM - PWM[2]
PA22	SSC0 - RX_CLOCK	PWM - PWM[3]
PA23	SSC0 - TX_CLOCK	TC1 - A0
PA24	SSC0 - TX_FRAME_SYNC	TC1 - A1
PA25	SSC0 - TX_DATA	TC1 - B0
PA26	SSC0 - RX_DATA	TC1 - B1
PA27	SPI1 - NPCS[3]	TC1 - CLK0
PA28	PWM - PWM[0]	TC1 - A2

Table 10-9. PIO Controller A Multiplexing

PA29	PWM - PWM[1]	TC1 - B2
PA30	SM - GCLK[0]	TC1 - CLK1
PA31	SM - GCLK[1]	TC1 - CLK2

10.7.2 PIO Controller B Multiplexing

Table 10-10. PIO Controller B Multiplexing

I/O Line	Peripheral A	Peripheral B
PB00	ISI - DATA[0]	SPI1 - MISO
PB01	ISI - DATA[1]	SPI1 - MOSI
PB02	ISI - DATA[2]	SPI1 - NPCS[0]
PB03	ISI - DATA[3]	SPI1 - NPCS[1]
PB04	ISI - DATA[4]	SPI1 - NPCS[2]
PB05	ISI - DATA[5]	SPI1 - SCK
PB06	ISI - DATA[6]	MCI - CMD[1]
PB07	ISI - DATA[7]	MCI - DATA[4]
PB08	ISI - HSYNC	MCI - DATA[5]
PB09	ISI - VSYNC	MCI - DATA[6]
PB10	ISI - PCLK	MCI - DATA[7]
PB11	PSIF - CLOCK[1]	ISI - DATA[8]
PB12	PSIF - DATA[1]	ISI - DATA[9]
PB13	SSC2 - TX_DATA	ISI - DATA[10]
PB14	SSC2 - RX_DATA	ISI - DATA[11]
PB15	SSC2 - TX_CLOCK	USART3 - CTS
PB16	SSC2 - TX_FRAME_SYNC	USART3 - RTS
PB17	SSC2 - RX_FRAME_SYNC	USART3 - TXD
PB18	SSC2 - RX_CLOCK	USART3 - RXD
PB19	SM - GCLK[2]	USART3 - CLK
PB20	DAC - DATA[1]	AC97C - SDO
PB21	DAC - DATA[0]	AC97C - SYNC
PB22	DAC - DATAN[1]	AC97C - SCLK
PB23	DAC - DATAN[0]	AC97C - SDI
PB24	NMI_N	DMAC - DMARQ[0]
PB25	EXTINT0	DMAC - DMARQ[1]
PB26	EXTINT1	USART2 - RXD
PB27	EXTINT2	USART2 - TXD
PB28	EXTINT3	USART2 - CLK
PB29	SM - GCLK[3]	USART2 - CTS
PB30	SM - GCLK[4]	USART2 - RTS

Table 10-11. PIO Controller C Multiplexing

PC16		
PC17		

Table 10-12. PIO Controller E Multiplexing

I/O Line	Peripheral A	Peripheral B
PE00	EBI - DATA[16]	
PE01	EBI - DATA[17]	
PE02	EBI - DATA[18]	
PE03	EBI - DATA[19]	
PE04	EBI - DATA[20]	
PE05	EBI - DATA[21]	
PE06	EBI - DATA[22]	
PE07	EBI - DATA[23]	
PE08	EBI - DATA[24]	
PE09	EBI - DATA[25]	
PE10	EBI - DATA[26]	
PE11	EBI - DATA[27]	
PE12	EBI - DATA[28]	
PE13	EBI - DATA[29]	
PE14	EBI - DATA[30]	
PE15	EBI - DATA[31]	
PE16	EBI - ADDR[23]	
PE17	EBI - ADDR[24]	
PE18	EBI - ADDR[25]	
PE19	EBI - CFCE1	
PE20	EBI - CFCE2	
PE21	EBI - NCS[4]	
PE22	EBI - NCS[5]	
PE23	EBI - CFRNW	
PE24	EBI - NWAIT	
PE25	EBI - NCS[2]	
PE26	EBI - SDCS	

10.7.5 IO Pins Without Multiplexing

Many of the external EBI pins are not controlled by the PIO modules, but directly driven by the EBI. These pins have programmable pullup resistors. These resistors are controlled by Special Function Register 4 (SFR4) in the HMATRIX. The pullup on the lines multiplexed with PIO is controlled by the appropriate PIO control register.

This SFR can also control CompactFlash, SmartMedia or NandFlash Support, see the EBI chapter for details

10.7.5.1 HMatrix SFR4 EBI Control Register

Name: HMATRIX_SFR4

Access Type: Read/Write

31	30	29	28	27	26	25	24
-	-	-	-	-	-	-	-
23	22	21	20	19	18	17	16
-	-	-	-	-	-	-	-
15	14	13	12	11	10	9	8
-	-	-	-	-	-	-	EBI_DBPUC
7	6	5	4	3	2	1	0
-	-	EBI_CS5A	EBI_CS4A	EBI_CS3A	-	EBI_CS1A	-

- **CS1A: Chip Select 1 Assignment**

0 = Chip Select 1 is assigned to the Static Memory Controller.

1 = Chip Select 1 is assigned to the SDRAM Controller.

- **CS3A: Chip Select 3 Assignment**

0 = Chip Select 3 is only assigned to the Static Memory Controller and NCS3 behaves as defined by the SMC.

1 = Chip Select 3 is assigned to the Static Memory Controller and the NAND Flash/SmartMedia Logic is activated.

- **CS4A: Chip Select 4 Assignment**

0 = Chip Select 4 is assigned to the Static Memory Controller and NCS4, NCS5 and NCS6 behave as defined by the SMC.

1 = Chip Select 4 is assigned to the Static Memory Controller and the CompactFlash Logic is activated.

- **CS5A: Chip Select 5 Assignment**

0 = Chip Select 5 is assigned to the Static Memory Controller and NCS4, NCS5 and NCS6 behave as defined by the SMC.

1 = Chip Select 5 is assigned to the Static Memory Controller and the CompactFlash Logic is activated.

Accessing the address space reserved to NCS5 and NCS6 may lead to an unpredictable outcome.

- **EBI_DBPUC: EBI Data Bus Pull-up Control**

0: EBI D[15:0] are internally pulled up to the VDDIO power supply. The pull-up resistors are enabled after reset.

1: EBI D[15:0] are not internally pulled up.

Table 10-13. IO Pins without multiplexing

I/O Line	Function
PX00	EBI - DATA[0]
PX01	EBI - DATA[1]
PX02	EBI - DATA[2]
PX03	EBI - DATA[3]
PX04	EBI - DATA[4]
PX05	EBI - DATA[5]
PX06	EBI - DATA[6]
PX07	EBI - DATA[7]
PX08	EBI - DATA[8]
PX09	EBI - DATA[9]
PX10	EBI - DATA[10]
PX11	EBI - DATA[11]
PX12	EBI - DATA[12]
PX13	EBI - DATA[13]
PX14	EBI - DATA[14]
PX15	EBI - DATA[15]
PX16	EBI - ADDR[0]
PX17	EBI - ADDR[1]
PX18	EBI - ADDR[2]
PX19	EBI - ADDR[3]
PX20	EBI - ADDR[4]
PX21	EBI - ADDR[5]
PX22	EBI - ADDR[6]
PX23	EBI - ADDR[7]
PX24	EBI - ADDR[8]
PX25	EBI - ADDR[9]
PX26	EBI - ADDR[10]
PX27	EBI - ADDR[11]
PX28	EBI - ADDR[12]
PX29	EBI - ADDR[13]
PX30	EBI - ADDR[14]
PX31	EBI - ADDR[15]

Table 10-13. IO Pins without multiplexing (Continued)

PX32	EBI - ADDR[16]
PX33	EBI - ADDR[17]
PX34	EBI - ADDR[18]
PX35	EBI - ADDR[19]
PX36	EBI - ADDR[20]
PX37	EBI - ADDR[21]
PX38	EBI - ADDR[22]
PX39	EBI - NCS[0]
PX40	EBI - NCS[1]
PX41	EBI - NCS[3]
PX42	EBI - NRD
PX43	EBI - NWE0
PX44	EBI - NWE1
PX45	EBI - NWE3
PX46	EBI - SDCK
PX47	EBI - SDCKE
PX48	EBI - RAS
PX49	EBI - CAS
PX50	EBI - SDWE
PX51	EBI - SDA10
PX52	EBI - NANDOE
PX53	EBI - NANDWE

10.8 Peripheral overview

10.8.1 External Bus Interface

- Optimized for Application Memory Space support
- Integrates Three External Memory Controllers:
 - Static Memory Controller
 - SDRAM Controller
 - ECC Controller
- Additional Logic for NAND Flash/SmartMedia™ and CompactFlash™ Support
 - SmartMedia support: 8-bit as well as 16-bit devices are supported
 - CompactFlash support: all modes (Attribute Memory, Common Memory, I/O, True IDE) are supported but the signals _IOIS16 (I/O and True IDE modes) and _ATA SEL (True IDE mode) are not handled.
- Optimized External Bus:
 - 16- or 32-bit Data Bus
 - Up to 26-bit Address Bus, Up to 64-Mbytes Addressable
 - Optimized pin multiplexing to reduce latencies on External Memories
- Up to 6 Chip Selects, Configurable Assignment:
 - Static Memory Controller on NCS0
 - SDRAM Controller or Static Memory Controller on NCS1
 - Static Memory Controller on NCS2
 - Static Memory Controller on NCS3, Optional NAND Flash/SmartMedia™ Support
 - Static Memory Controller on NCS4 - NCS5, Optional CompactFlash™ Support

10.8.2 Static Memory Controller

- 6 Chip Selects Available
- 64-Mbyte Address Space per Chip Select
- 8-, 16- or 32-bit Data Bus
- Word, Halfword, Byte Transfers
- Byte Write or Byte Select Lines
- Programmable Setup, Pulse And Hold Time for Read Signals per Chip Select
- Programmable Setup, Pulse And Hold Time for Write Signals per Chip Select
- Programmable Data Float Time per Chip Select
- Compliant with LCD Module
- External Wait Request
- Automatic Switch to Slow Clock Mode
- Asynchronous Read in Page Mode Supported: Page Size Ranges from 4 to 32 Bytes

10.8.3 SDRAM Controller

- Numerous Configurations Supported
 - 2K, 4K, 8K Row Address Memory Parts
 - SDRAM with Two or Four Internal Banks
 - SDRAM with 16- or 32-bit Data Path
- Programming Facilities
 - Word, Half-word, Byte Access
 - Automatic Page Break When Memory Boundary Has Been Reached
 - Multibank Ping-pong Access
 - Timing Parameters Specified by Software
 - Automatic Refresh Operation, Refresh Rate is Programmable

- Energy-saving Capabilities
 - Self-refresh, Power-down and Deep Power Modes Supported
 - Supports Mobile SDRAM Devices
- Error Detection
 - Refresh Error Interrupt
- SDRAM Power-up Initialization by Software
- CAS Latency of 1, 2, 3 Supported
- Auto Precharge Command Not Used

10.8.4 Error Corrected Code Controller

- Hardware Error Corrected Code (ECC) Generation
 - Detection and Correction by Software
- Supports NAND Flash and SmartMedia™ Devices with 8- or 16-bit Data Path.
- Supports NAND Flash/SmartMedia with Page Sizes of 528, 1056, 2112 and 4224 Bytes, Specified by Software

10.8.5 Serial Peripheral Interface

- Supports communication with serial external devices
 - Four chip selects with external decoder support allow communication with up to 15 peripherals
 - Serial memories, such as DataFlash™ and 3-wire EEPROMs
 - Serial peripherals, such as ADCs, DACs, LCD Controllers, CAN Controllers and Sensors
 - External co-processors
- Master or slave serial peripheral bus interface
 - 8- to 16-bit programmable data length per chip select
 - Programmable phase and polarity per chip select
 - Programmable transfer delays between consecutive transfers and between clock and data per chip select
 - Programmable delay between consecutive transfers
 - Selectable mode fault detection
- Very fast transfers supported
 - Transfers with baud rates up to MCK
 - The chip select line may be left active to speed up transfers on the same device

10.8.6 Two-wire Interface

- Compatibility with standard two-wire serial memory
- One, two or three bytes for slave address
- Sequential read/write operations

10.8.7 USART

- Programmable Baud Rate Generator
- 5- to 9-bit full-duplex synchronous or asynchronous serial communications
 - 1, 1.5 or 2 stop bits in Asynchronous Mode or 1 or 2 stop bits in Synchronous Mode
 - Parity generation and error detection
 - Framing error detection, overrun error detection
 - MSB- or LSB-first
 - Optional break generation and detection
 - By 8 or by-16 over-sampling receiver frequency
 - Hardware handshaking RTS-CTS
 - Receiver time-out and transmitter timeguard
 - Optional Multi-drop Mode with address generation and detection
 - Optional Manchester Encoding
- RS485 with driver control signal
- ISO7816, T = 0 or T = 1 Protocols for interfacing with smart cards
 - NACK handling, error counter with repetition and iteration limit
- IrDA modulation and demodulation
 - Communication at up to 115.2 Kbps
- Test Modes 46
 - Remote Loopback, Local Loopback, Automatic Echo

10.8.8 Serial Synchronous Controller

- Provides serial synchronous communication links used in audio and telecom applications (with CODECs in Master or Slave Modes, I2S, TDM Buses, Magnetic Card Reader, etc.)
- Contains an independent receiver and transmitter and a common clock divider
- Offers a configurable frame sync and data length
- Receiver and transmitter can be programmed to start automatically or on detection of different event on the frame sync signal
- Receiver and transmitter include a data signal, a clock signal and a frame synchronization signal

10.8.9 AC97 Controller

- Compatible with AC97 Component Specification V2.2
- Capable to Interface with a Single Analog Front end
- Three independent RX Channels and three independent TX Channels
 - One RX and one TX channel dedicated to the AC97 Analog Front end control
 - One RX and one TX channel for data transfers, connected to the DMAC
 - One RX and one TX channel for data transfers, connected to the DMAC
- Time Slot Assigner allowing to assign up to 12 time slots to a channel
- Channels support mono or stereo up to 20 bit sample length - Variable sampling rate AC97 Codec Interface (48KHz and below)

10.8.10 Audio DAC

- Digital Stereo DAC
- Oversampled D/A conversion architecture
 - Oversampling ratio fixed 128x
 - FIR equalization filter
 - Digital interpolation filter: Comb4
 - 3rd Order Sigma-Delta D/A converters
- Digital bitstream outputs
- Parallel interface
- Connected to DMA Controller for background transfer without CPU intervention

10.8.11 Timer Counter

- Three 16-bit Timer Counter Channels
- Wide range of functions including:
 - Frequency Measurement
 - Event Counting
 - Interval Measurement
 - Pulse Generation
 - Delay Timing
 - Pulse Width Modulation
 - Up/down Capabilities
- Each channel is user-configurable and contains:
 - Three external clock inputs
 - Five internal clock inputs
 - Two multi-purpose input/output signals
- Two global registers that act on all three TC Channels

10.8.12 Pulse Width Modulation Controller

- 4 channels, one 16-bit counter per channel
- Common clock generator, providing Thirteen Different Clocks
 - A Modulo n counter providing eleven clocks
 - Two independent Linear Dividers working on modulo n counter outputs
- Independent channel programming
 - Independent Enable Disable Commands
 - Independent Clock
 - Independent Period and Duty Cycle, with Double Bufferization
 - Programmable selection of the output waveform polarity
 - Programmable center or left aligned output waveform

10.8.13 Multimedia Card Interface

- 2 double-channel Multimedia Card Interface, allowing concurrent transfers with 2 cards
- Compatibility with MultiMedia Card Specification Version 2.2
- Compatibility with SD Memory Card Specification Version 1.0
- Compatibility with SDIO Specification Version V1.0.
- Cards clock rate up to Master Clock divided by 2
- Embedded power management to slow down clock rate when not used
- Each MCI has two slot, each supporting
 - One slot for one MultiMediaCard bus (up to 30 cards) or
 - One SD Memory Card
- Support for stream, block and multi-block data read and write

10.8.14 PS/2 Keyboard Interface

- Peripheral Bus slave
- PS/2 Host
- Receive and transmit capability
- Parity generation and error detection
- Overrun error detection

10.8.15 USB Device Port

- USB V2.0 high-speed compliant, 480 Mbits per second
- Embedded USB V2.0 high-speed transceiver
- Embedded dual-port RAM for endpoints
- Suspend/Resume logic
- Ping-pong mode (two memory banks) for isochronous and bulk endpoints
- Six general-purpose endpoints
 - Endpoint 0, Endpoint 3: 8 bytes, no ping-pong mode
 - Endpoint 1, Endpoint 2: 64 bytes, ping-pong mode
 - Endpoint 4, Endpoint 5: 256 bytes, ping-pong mode

-

10.8.16 Image Sensor Interface

- ITU-R BT. 601/656 8-bit mode external interface support
- Support for ITU-R BT.656-4 SAV and EAV synchronization
- Vertical and horizontal resolutions up to 2048 x 2048
- Preview Path up to 640*480
- Support for packed data formatting for YCbCr 4:2:2 formats
- Preview scaler to generate smaller size image 50
- Programmable frame capture rate

11. Power Manager

Rev: 1.0.2.1

11.1 Features

- Controls oscillators and PLL's
- Generates clocks and resets for digital logic
- Supports 2 crystal oscillators 10 to 27 MHz
- Supports 2 PLL's 80 to 150 MHz
- Supports 32KHz ultra-low power oscillator
- On-the fly frequency change of CPU, HSB, and PB frequency
- Sleep modes allow simple disabling of logic clocks, PLL's and oscillators
- Module-level clock gating through maskable peripheral clocks
- Wake-up from interrupts or external pin
- Generic clocks with wide frequency range provided
- Automatic identification of reset sources

11.2 Description

The Power Manager (PM) controls the oscillators, PLL's, and generates the clocks and resets in the device. The PM controls two fast crystal oscillators, as well as two PLL's, which can multiply the clock from either oscillator to provide higher frequencies. Additionally, a low-power 32KHz oscillator is used to generate a slow clock for real-time counters.

The provided clocks are divided into synchronous and generic clocks. The synchronous clocks are used to clock the main digital logic in the device, namely the CPU, and the modules and peripherals connected to the HSB, PBA, and PBB buses. The generic clocks are asynchronous clocks, which can be tuned precisely within a wide frequency range, which makes them suitable for peripherals that require specific frequencies, such as timers and communication modules.

The PM also contains advanced power-saving features, allowing the user to optimize the power consumption for an application. The synchronous clocks are divided into four clock domains, for the CPU, and modules on the HSB, PBA, and PBB buses. The four clocks can run at different speeds, so the user can save power by running peripherals at a relatively low clock, while maintaining a high CPU performance. Additionally, the clocks can be independently changed on-the fly, without halting any peripherals. This enables the user to adjust the speed of the CPU and memories to the dynamic load of the application, without disturbing or re-configuring active peripherals.

Each module also has a separate clock, enabling the user to switch off the clock for inactive modules, to save further power. Additionally, clocks and oscillators can be automatically switched off during idle periods by using the sleep instruction on the CPU. The system will return to normal on occurrence of interrupts or an event on the WAKE_N pin.

The Power Manager also contains a Reset Controller, which collects all possible reset sources, generates hard and soft resets, and allows the reset source to be identified by software.

11.3 Block Diagram

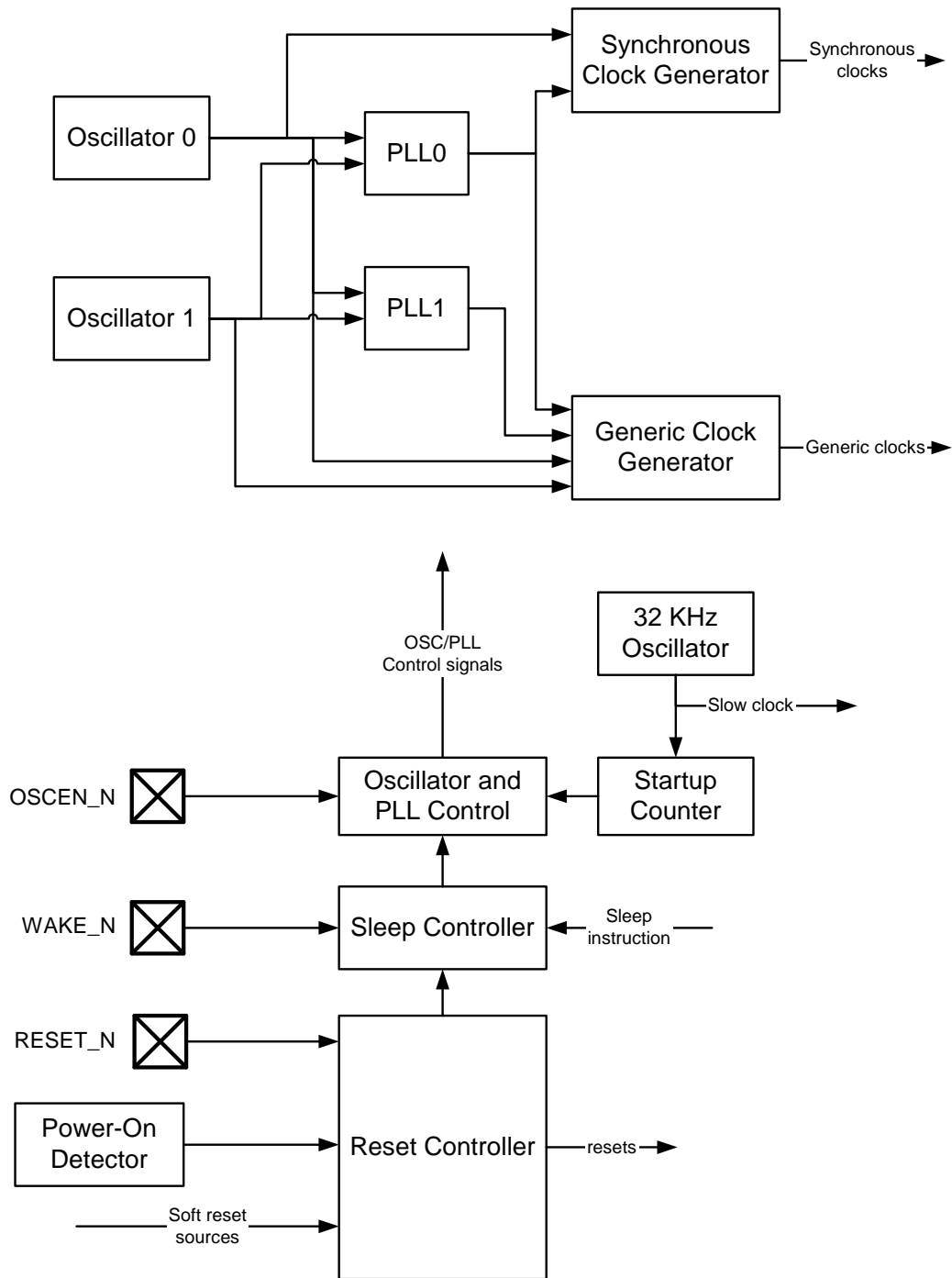

11.4 Product Dependencies

11.4.1 I/O Lines

The PM provides a number of generic clock outputs, which can be connected to output pins, multiplexed with PIO lines. The programmer must first program the PIO controller to assign these pins to their peripheral function. If the I/O pins of the PM are not used by the application, they can be used for other purposes by the PIO controller.

The PM also has a dedicated WAKE_N pin, as well as a number of pins for oscillators and PLL's, which do not require the PIO controller to be programmed.

11.4.2 Interrupt

The PM interrupt line is connected to one of the internal sources of the interrupt controller. Using the PM interrupt requires the interrupt controller to be programmed first.

11.5 Functional Description

11.5.1 Oscillator 0 and 1 operation

The two main oscillators are designed to be used with an external 10 to 27 MHz crystal, as shown in [Figure 11-1](#). The main oscillators are enabled by default after reset, and are only switched off in sleep modes, as described in [Section 11.5.6 on page 99](#). After a power-on reset, or when waking up from a sleep mode that disabled the main oscillators, the oscillators need 128 slow clock cycles to stabilize on the correct frequency. The PM masks the main oscillator outputs during this start-up period, to ensure that no unstable clocks propagate to the digital logic.

The oscillators can be bypassed by pulling the OSCEN_N pin high. This disables the oscillators, and an external clock must be applied on XIN. No start-up time applies to this clock.

Figure 11-1. Oscillator connections

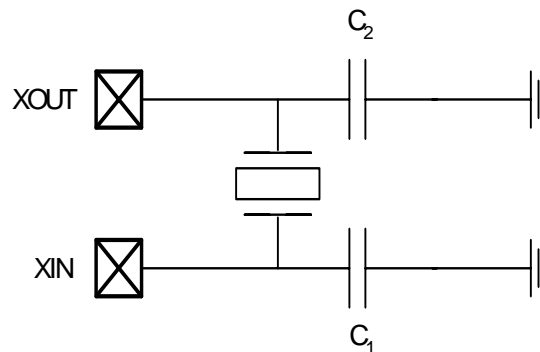

11.5.2 32 KHz oscillator operation

The 32 KHz oscillator operates similarly to Oscillator 0 and 1 described above, and is used to generate the slow clock in the device. A 32768 Hz crystal must be connected between XIN32 and XOUT32 as shown in [Figure 11-1](#). The 32 KHz oscillator is an ultra-low power design, and remains enabled in all sleep modes except static mode, as described in [Section 11.5.6 on page 99](#). The oscillator has a rather long start-up time of 32768 clock cycles, and no clocks will be generated in the device during this start-up time.

Note that in static sleep mode the startup counter will start at the negedge of reset and not at the posedge.

Pulling OSCEN_N high will also disable the 32 KHz oscillator, and a 32 KHz clock must be applied on the XIN32 pin. No start-up time applies to this clock.

11.5.3 PLL operation

The device contains two PLL's, PLL0 and PLL1. These are disabled by default, but can be enabled to provide high frequency source clocks for synchronous or generic clocks. The PLL's can take either Oscillator 0 or 1 as clock source. Each PLL has an input divider, which divides the source clock, creating the reference clock for the PLL. The PLL output is divided by a user-defined factor, and the PLL compares the resulting clock to the reference clock. The PLL will adjust its output frequency until the two compared clocks are equal, thus locking the output frequency to a multiple of the reference clock frequency.

When the PLL is switched on, or when changing the clock source or multiplication or division factor for the PLL, the PLL is unlocked and the output frequency is undefined. The PLL clock for the digital logic is automatically masked when the PLL is unlocked, to prevent connected digital logic from receiving a too high frequency and thus become unstable.

Figure 11-2. PLL with control logic and filters

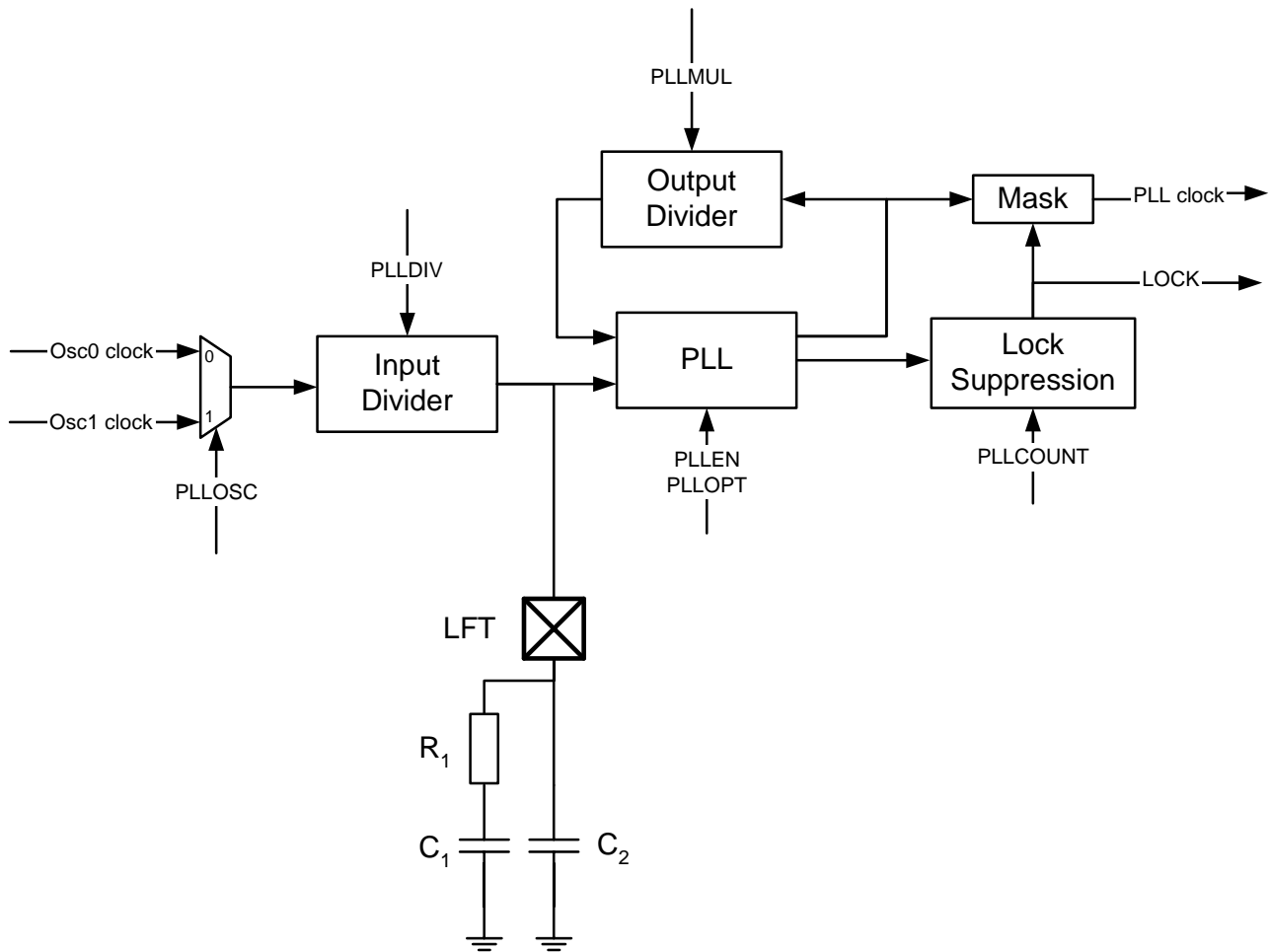

11.5.3.1 Enabling the PLL

PLL_n is enabled by writing the PLEN bit in the PLL_n register. PLLOSC selects Oscillator 0 or 1 as clock source. The PLLDIV and PLLMUL bitfields must be written with the division and multiplication factor, respectively, creating the PLL frequency:

$$f_{PLL} = (PLLMUL+1)/(PLLDIV+1) \cdot f_{OSC}$$

The LOCK_n flag in ISR is set when PLL_n becomes locked. The bit will stay high until cleared by writing 1 to ICR:LOCK_n. The Power Manager interrupt can be triggered by writing IER:LOCK_n to 1.

11.5.3.2 Lock suppression

When using high division or multiplication factors, there is a possibility that the PLL can give false lock indications while sweeping to the correct frequency. To prevent false lock indications from setting the LOCK_n flag, the lock indication can be suppressed for a number of slow clock

cycles indicated in the PLLn:COUNT field. Typical start-up times can be found using the Atmel filter calculator (see below).

11.5.3.3 Operating range selection

To use PLLn, a passive RC filter should be connected to the LFTn pin, as shown in [Figure 11-2](#). Filter values depend on the PLL reference and output frequency range. Atmel provides a tool named “Atmel PLL LFT Filter Calculator AT91” available for download at the Atmel web site. The PLL for AT32AP7001 can be selected in this tool by selecting “AT91RM9200 (58A07F)” and leave “lcp = ‘1’” (default).

Similarly, the PLLn:PLLOPT field should be set to proper values according to the PLL operating frequency, as described in [Section 11.6.4 on page 108](#).

11.5.4 Synchronous clocks

Oscillator 0 (default) or PLL0 provides the source for the main clocks, which is the common root for the synchronous clocks for the CPU, and HSB, PBA, and PBB modules. The main clock is divided by an 8-bit prescaler, and each of these four synchronous clocks can run from any tapping of this prescaler, or the undivided main clock, as long as $f_{CPU} \geq f_{HSB} \geq f_{PBA}$. The synchronous clock source can be changed on-the fly, responding to varying load in the application. The clock domains can be shut down in sleep mode, as described in [“Sleep modes” on page 99](#). Additionally, the clocks for each module in the four domains can be individually masked, to avoid power consumption in inactive modules.

Figure 11-3. Synchronous clock generation

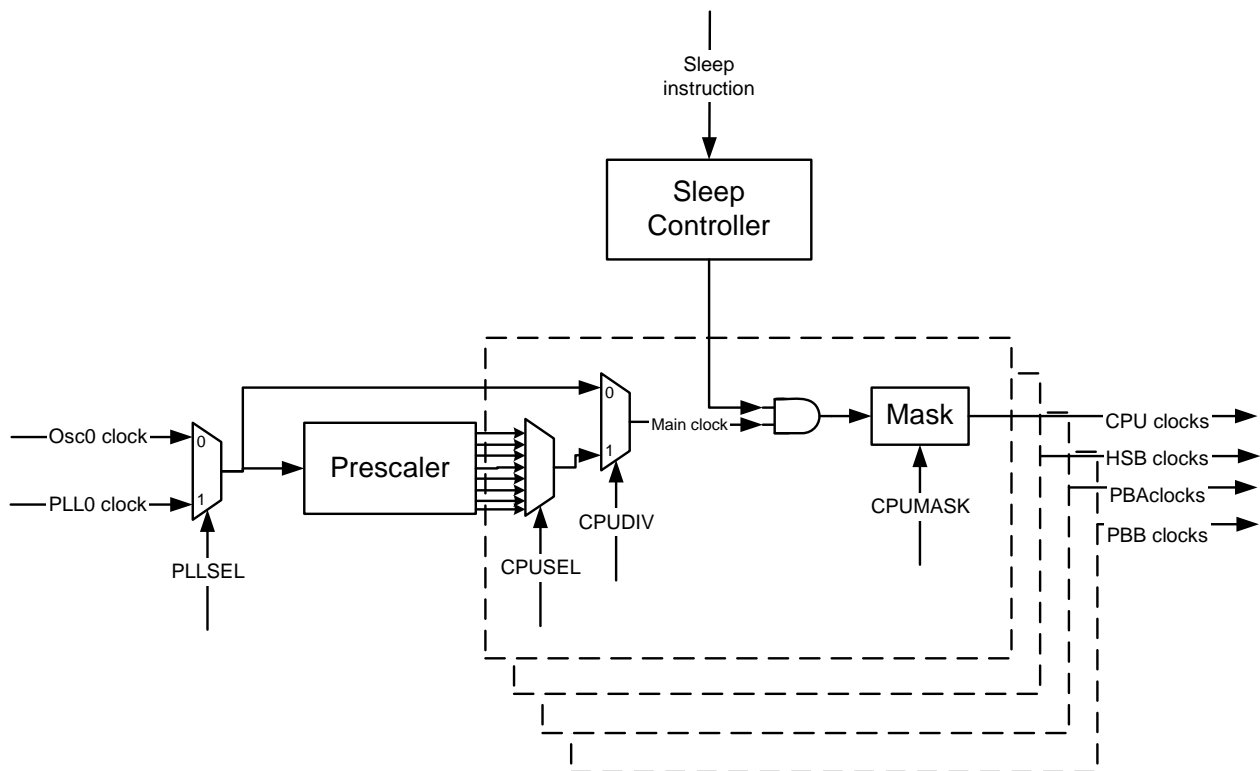

11.5.4.1 Selecting PLL or oscillator for the main clock

The common main clock can be connected to Oscillator 0 or PLL0. By default, the main clock will be connected to the Oscillator 0 output. The user can connect the main clock to the PLL0 output by writing the PLLSEL bit in the Main Clock Control Register (MCCTRL) to 1. This must only be done after PLL0 has been enabled, otherwise a deadlock will occur. Care should also be taken that the new frequency of the synchronous clocks does not exceed the maximum frequency for each clock domain.

11.5.4.2 Selecting synchronous clock division ratio

The main clock feeds an 8-bit prescaler, which can be used to generate the synchronous clocks. By default, the synchronous clocks run on the undivided main clock. The user can select a prescaler division for the CPU clock by writing CKSEL:CPUDIV to 1 and CPUSEL to the prescaling value, resulting in a CPU clock frequency:

$$f_{\text{CPU}} = f_{\text{main}} / 2^{(\text{CPUSEL}+1)}$$

Similarly, the clock for HSB, PBA, and PBB can be divided by writing their respective bitfields. To ensure correct operation, frequencies must be selected so that $f_{\text{CPU}} \geq f_{\text{HSB}} \geq f_{\text{PBA,B}}$. Also, frequencies must never exceed the specified maximum frequency for each clock domain.

CKSEL can be written without halting or disabling peripheral modules. Writing CKSEL allows a new clock setting to be written to all synchronous clocks at the same time. It is possible to keep one or more clocks unchanged by writing the same value a before to the xxxDIV and xxxSEL bitfields. This way, it is possible to e.g. scale CPU and HSB speed according to the required performance, while keeping the PBA and PBB frequency constant.

11.5.4.3 Clock Ready flag

There is a slight delay from CKSEL is written and the new clock setting becomes effective. During this interval, the Clock Ready (CKRDY) flag in ISR will read as 0. If IER:CKRDY is written to 1, the Power Manager interrupt can be triggered when the new clock setting is effective. CKSEL must not be re-written while CKRDY is 0, or the system may become unstable or hang.

11.5.5 Peripheral clock masking

By default, the clock for all modules are enabled, regardless of which modules are actually being used. It is possible to disable the clock for a module in the CPU, HSB, PBA, or PBB clock domain by writing the corresponding bit in the Clock Mask register (CPU/HSB/PBA/PBB) to 0. When a module is not clocked, it will cease operation, and its registers cannot be read or written. The module can be re-enabled later by writing the corresponding mask bit to 1.

A module may be connected to several clock domains, in which case it will have several mask bits.

[Table 11-1](#) contains a list of implemented maskable clocks.

11.5.5.1 Cautionary note

Note that clocks should only be switched off if it is certain that the module will not be used. Switching off the clock for the internal RAM will cause a problem if the stack is mapped there. Switching off the clock to the System Manager (SM), which contains the mask registers, or the corresponding PB bridge, will make it impossible to write the mask registers again. In this case, they can only be re-enabled by a system reset.

11.5.5.2 *Mask Ready flag*

Due to synchronization in the clock generator, there is a slight delay from a mask register is written until the new mask setting goes into effect. When clearing mask bits, this delay can usually be ignored. However, when setting mask bits, the registers in the corresponding module must not be written until the clock has actually be re-enabled. The status flag MSKRDY in ISR provides the required mask status information. When writing either mask register with any value, this bit is cleared. The bit is set when the clocks have been enabled and disabled according to the new mask setting. Optionally, the Power Manager interrupt can be enabled by writing the MSKRDY bit in IER.

Table 11-1. Maskable module clocks in AT32AP7001.

Bit	CPUMASK	HSBMASK	PBAMASK	PBBMASK
0	PICO	EBI	SPI0	SM
1	-	PBA	SPI1	INTC
2	-	PBB	TWI	HMATRIX
3	-	HRAMC	USART0	TC0
4	-	HSB-HSB Bridge	USART1	TC1
5	-	ISI	USART2	PWM
6	-	USB	USART3	MACB0
7	-	LCDC	SSC0	MACB1
8	-	MACB0	SSC1	DAC
9	-	MACB1	SSC2	MCI
10	-	DMA	PIOA	AC97C
11	-	-	PIOB	ISI
12	-	-	PIOC	USB
13	-	-	PIOD	SMC
14	-	-	PIOE	SDRAMC
15	-	-	PSIF	ECC
16	-	-	PDC	-
31: 17	-	-	-	-

11.5.6 Sleep modes

In normal operation, all clock domains are active, allowing software execution and peripheral operation. When the CPU is idle, it is possible to switch off the CPU clock and optionally other clock domains to save power. This is activated by the sleep instruction, which takes the sleep mode index number as argument.

11.5.6.1 Entering and exiting sleep modes

The sleep instruction will halt the CPU and all modules belonging to the stopped clock domains. The modules will be halted regardless of the bit settings of the mask registers.

Oscillators and PLL's can also be switched off to save power. These modules have a relatively long start-up time, and are only switched off when very low power consumption is required.

The CPU and affected modules are restarted when the sleep mode is exited. This occurs when an interrupt triggers, or the WAKE_N pin is asserted. Note that even though an interrupt is enabled in sleep mode, it may not trigger if the source module is not clocked.

11.5.6.2 Supported sleep modes

The following sleep modes are supported. These are detailed in [Table 11-2](#).

- Idle: The CPU is stopped, the rest of the chip is operating. Wake-up sources are any interrupt, or WAKE_N pin.
- Frozen: The CPU and HSB modules are stopped, peripherals are operating. Wake-up sources are any interrupt from PB modules, or WAKE_N pin.
- Standby: All synchronous clocks are stopped, but oscillators and PLL's are running, allowing quick wake-up to normal mode. Wake-up sources are RTC or external interrupt, or WAKE_N pin.
- Stop: As Standby, but Oscillator 0 and 1, and the PLL's are stopped. 32 KHz oscillator and RTC/WDT still operates. Wake-up sources are RTC or external interrupt, or WAKE_N pin.
- Static: All oscillators and clocks are stopped. Wake-up sources are external interrupt or WAKE_N pin.

Table 11-2. Sleep modes

Index	Sleep Mode	CPU	HSB	PBA,B + GCLK	Osc0,1 + PLL0,1	Osc32 + RTC/WDT
0	Idle	Off	On	On	On	On
1	Frozen	Off	Off	On	On	On
2	Standby	Off	Off	Off	On	On
3	Stop	Off	Off	Off	Off	On
5	Static	Off	Off	Off	Off	Off

11.5.6.3 Precautions when entering sleep mode

Modules communicating with external circuits should normally be disabled before entering a sleep mode that will stop the module operation. This prevents erratic behavior when entering or exiting sleep mode. Please refer to the relevant module documentation for recommended actions.

Communication between the synchronous clock domains is disturbed when entering and exiting sleep modes. This means that bus transactions are not allowed between clock domains affected by the sleep mode. The system may hang if the bus clocks are stopped in the middle of a bus transaction.

The CPU and caches are automatically stopped in a safe state to ensure that all CPU bus operations are complete when the sleep mode goes into effect. Thus, when entering Idle mode, no further action is necessary.

When entering a deeper sleep mode than Idle mode, all other HSB masters must be stopped before entering the sleep mode. Also, if there is a chance that any PB write operations are incomplete, the CPU should perform a read operation from any register on the PB bus before executing the sleep instruction. This will stall the CPU while waiting for any pending PB operations to complete.

The Power manager will leave some clocks running if the OCD is in debug mode or there is a memory access instruction loaded in the JTAG. To ensure that the correct sleep mode is exe-

cutted debug mode should be turned off and the IDCODE instruction should be loaded into the instruction register of the JTAG.

11.5.7 Generic clocks

Timers, communication modules, and other modules connected to external circuitry may require specific clock frequencies to operate correctly. The Power Manager contains an implementation defined number of generic clocks, that can provide a wide range of accurate clock frequencies.

Each generic clock module runs from either Oscillator 0 or 1, or PLL0 or 1. The selected source can optionally be divided by any even integer up to 512. Each clock can be independently enabled and disabled, and is also automatically disabled along with peripheral clocks by the Sleep Controller.

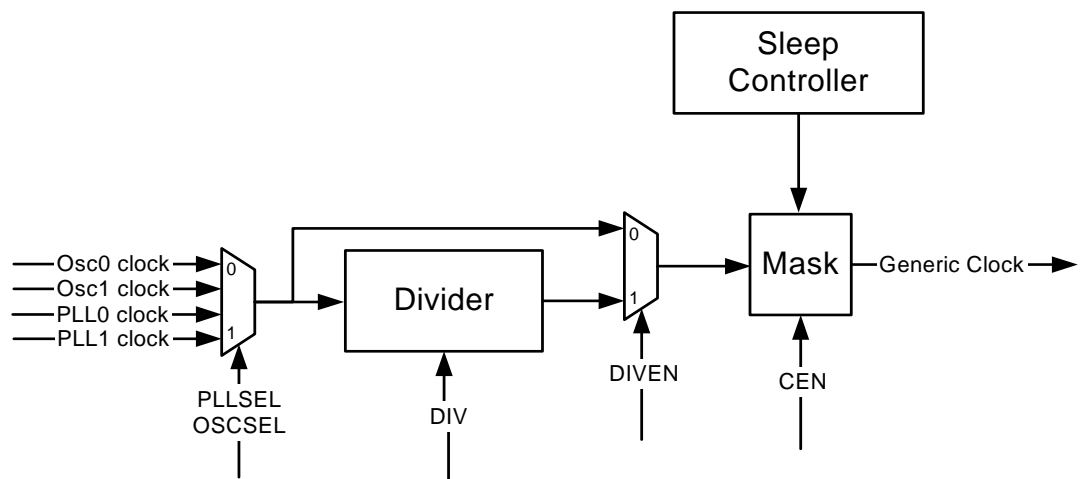

Figure 11-4. Generic clock generation

11.5.7.1 Enabling a generic clock

A generic clock is enabled by writing the CEN bit in GCCTRL to 1. Each generic clock can use either Oscillator 0 or 1 or PLL0 or 1 as source, as selected by the PLLSEL and OSCSEL bits. The source clock can optionally be divided by writing DIVEN to 1 and the division factor to DIV, resulting in the output frequency:

$$f_{GCLK} = f_{SRC} / (2 * (DIV + 1))$$

11.5.7.2 Disabling a generic clock

The generic clock can be disabled by writing CEN to 0 or entering a sleep mode that disables the PB clocks. In either case, the generic clock will be switched off on the first falling edge after the disabling event, to ensure that no glitches occur. If CEN is written to 0, the bit will still read as 1 until the next falling edge occurs, and the clock is actually switched off. When writing CEN to 0, the other bits in GCCTRL should not be changed until CEN reads as 0, to avoid glitches on the generic clock.

When the clock is disabled, both the prescaler and output are reset.

11.5.7.3 Changing clock frequency

When changing generic clock frequency by writing GCCTRL, the clock should be switched off by the procedure above, before being re-enabled with the new clock source or division setting. This prevents glitches during the transition.

11.5.7.4 Generic clock implementation

In AT32AP7001, there are 8 generic clocks. These are allocated to different functions as shown in [Table 11-3](#).

Table 11-3. Generic clock allocation

Clock number	Function
0	GCLK0 pin
1	GCLK1 pin
2	GCLK2 pin
3	GCLK3 pin
4	GCLK4 pin
5	Reserved for internal use
6	DAC
7	LCD Controller

11.5.8 Divided PB clocks

The clock generator in the Power Manager provides divided PBA and PBB clocks for use by peripherals that require a prescaled PB clock. This is described in the documentation for the relevant modules.

The divided clocks are not directly maskable, but are stopped in sleep modes where the PB clocks are stopped.

11.5.9 Debug operation

During a debug session, the user may need to halt the system to inspect memory and CPU registers. The clocks normally keep running during this debug operation, but some peripherals may require the clocks to be stopped, e.g. to prevent timer overflow, which would cause the program to fail. For this reason, peripherals on the PBA and PBB buses may use “debug qualified” PB clocks. This is described in the documentation for the relevant modules. The divided PB clocks are always debug qualified clocks.

Debug qualified PB clocks are stopped during debug operation. The debug system can optionally keep these clocks running during the debug operation. This is described in the documentation for the On-Chip Debug system.

11.5.10 Reset Controller

The Reset Controller collects the various reset sources in the system and generates hard and soft resets for the digital logic.

The device contains a Power-On Detector, which keeps the system reset until power is stable. This eliminates the need for external reset circuitry to guarantee stable operation when powering up the device.

It is also possible to reset the device by asserting the RESET_N pin. This pin has an internal pull-up, and does not need to be driven externally when negated.

Table 11-4 lists these and other reset sources supported by the Reset Controller.

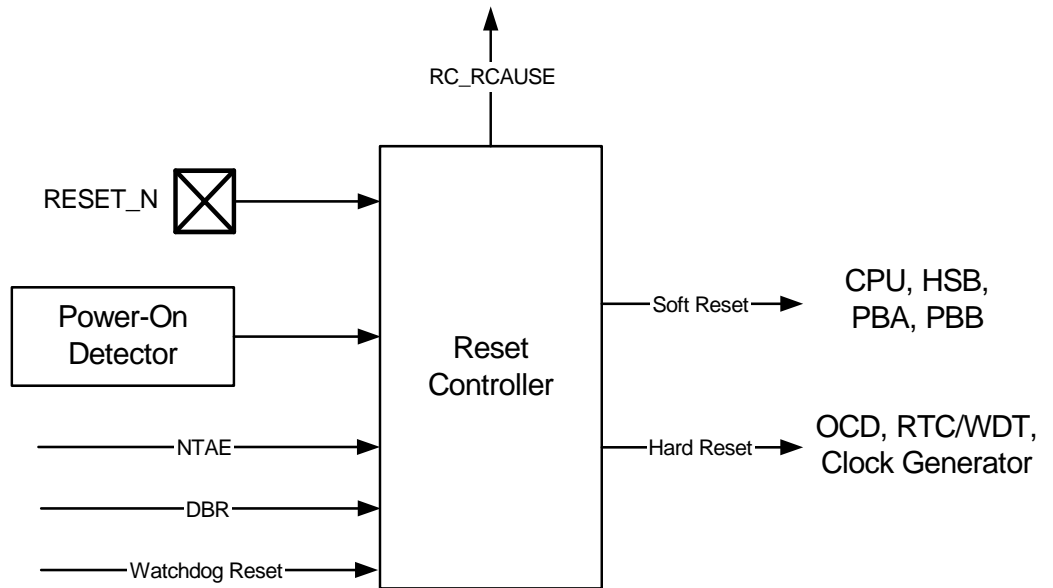

Figure 11-5. Reset Controller block diagram

Reset sources are divided into hard and soft resets. Hard resets imply that the system could have become unstable, and virtually all logic will be reset. The clock generator, which also controls the oscillators, will also be reset. If the device is reset due to a power-on reset, or reset occurred when the device was in a sleep mode that disabled the oscillators, the normal oscillator startup time will apply.

A soft reset will reset most digital logic in the device, such as CPU, HSB, and PB modules, but not the OCD system, clock generator, Watchdog Timer and RTC, allowing some functions, including the oscillators, to remain active during the reset. The startup time from a soft reset is thus negligible. Note that all PB registers are reset, except those in the RTC/WDT. The MCCTRL and CKSEL registers are reset, and the device will restart using Oscillator 0 as clock source for all synchronous clocks.

In addition to the listed reset types, the JTAG can keep parts of the device statically reset through the JTAG Reset Register. See JTAG documentation for details.

The cause of the last reset can be read from the RC_RCAUSE register. This register contains one bit for each reset source, and can be identified during the boot sequence of an application to determine the proper action to be taken.

Table 11-4. Reset types

Reset source	Description	Type
Power-on Reset	Supply voltage below the power-on reset detector threshold voltage	Hard
External	RESET_N pin asserted	Hard
NanoTrace Access Error	See On-Chip Debug documentation.	Soft
Watchdog Timer	See watchdog timer documentation.	Soft
OCD	See On-Chip Debug documentation	Soft

11.6 User Interface

Offset	Register	Register Name	Access	Reset
0x00	Main Clock Control	MCCTRL	Read/Write	0x0
0x04	Clock Select	CKSEL	Read/Write	0x0
0x08	CPU Clock Mask	CPUMASK	Read/Write	Impl. defined
0x0C	HSB Clock Mask	HSBMASK	Read/Write	Impl. defined
0x10	PBA Clock Mask	PBAMASK	Read/Write	Impl. defined
0x14	PBB Clock Mask	PBBMASK	Read/Write	Impl. defined
0x20	PLL0 Control	PLL0	Read/Write	0x0
0x24	PLL1 Control	PLL1	Read/Write	0x0
0x40	Interrupt Enable	IER	Write-only	0x0
0x44	Interrupt Disable	IDR	Write-only	0x0
0x48	Interrupt Mask	IMR	Read-only	0x0
0x4C	Interrupt Status	ISR	Read-only	0x0
0x50	Interrupt Clear	ICR	Write-only	0x0
0x60	Generic Clock Control 0	GCCTRL0	Read/Write	0x0
0x64	Generic Clock Control 1	GCCTRL1	Read/Write	0x0
0x68	Generic Clock Control 2	GCCTRL2	Read/Write	0x0
0x6C	Generic Clock Control 3	GCCTRL3	Read/Write	0x0
0x70	Generic Clock Control 4	GCCTRL4	Read/Write	0x0
0x74	Generic Clock Control 5	GCCTRL5	Read/Write	0x0
0x78	Generic Clock Control 6	GCCTRL6	Read/Write	0x0
0x7C	Generic Clock Control 7	GCCTRL7	Read/Write	0x0

11.6.1 Main Clock Control

Name: MCCTRL
Access Type: Read/Write

31	30	29	28	27	26	25	24
-	-	-	-	-	-	-	-
23	22	21	20	19	18	17	16
-	-	-	-	-	-	-	-
15	14	13	12	11	10	9	8

-	-	-	-	-	-	-	-
7	6	5	4	3	2	1	0
-	-	-	-	-	-	PLLSEL	-

• **PLLSEL: PLL Select**

- 0: Oscillator 0 is source for the main clock
- 1: PLL0 is source for the main clock

11.6.2 Clock Select

Name: CKSEL
Access Type: Read/Write

31	30	29	28	27	26	25	24
PBBDIV	-	-	-	-	PBBSEL		
23	22	21	20	19	18	17	16
PBADIV	-	-	-	-	PBASEL		
15	14	13	12	11	10	9	8
HSBDIV	-	-	-	-	HSBSEL		
7	6	5	4	3	2	1	0
CPUDIV	-	-	-	-	CPUSEL		

• **PBBDIV, PBBSEL: PBB Division and Clock Select**

- PBBDIV = 0: PBB clock equals main clock.
- PBBDIV = 1: PBB clock equals main clock divided by $2^{(PBBSEL+1)}$.

• **PBADIV, PBASEL: PBA Division and Clock Select**

- PBADIV = 0: PBA clock equals main clock.
- PBADIV = 1: PBA clock equals main clock divided by $2^{(PBASEL+1)}$.

• **HSBDIV, HSBSEL: HSB Division and Clock Select**

- HSBDIV = 0: HSB clock equals main clock.
- HSBDIV = 1: HSB clock equals main clock divided by $2^{(HSBSEL+1)}$.

• **CPUDIV, CPUSEL: CPU Division and Clock Select**

- CPUDIV = 0: CPU clock equals main clock.
- CPUDIV = 1: CPU clock equals main clock divided by $2^{(CPUSEL+1)}$.

Note that if xxxDIV is written to 0, xxxSEL should also be written to 0 to ensure correct operation.

Also note that writing this register clears ISR:CKRDY. The register must not be re-written until CKRDY goes high.

11.6.3 Clock Mask

Name: CPU/HSB/PBA/PBBMASK

Access Type: Read/Write

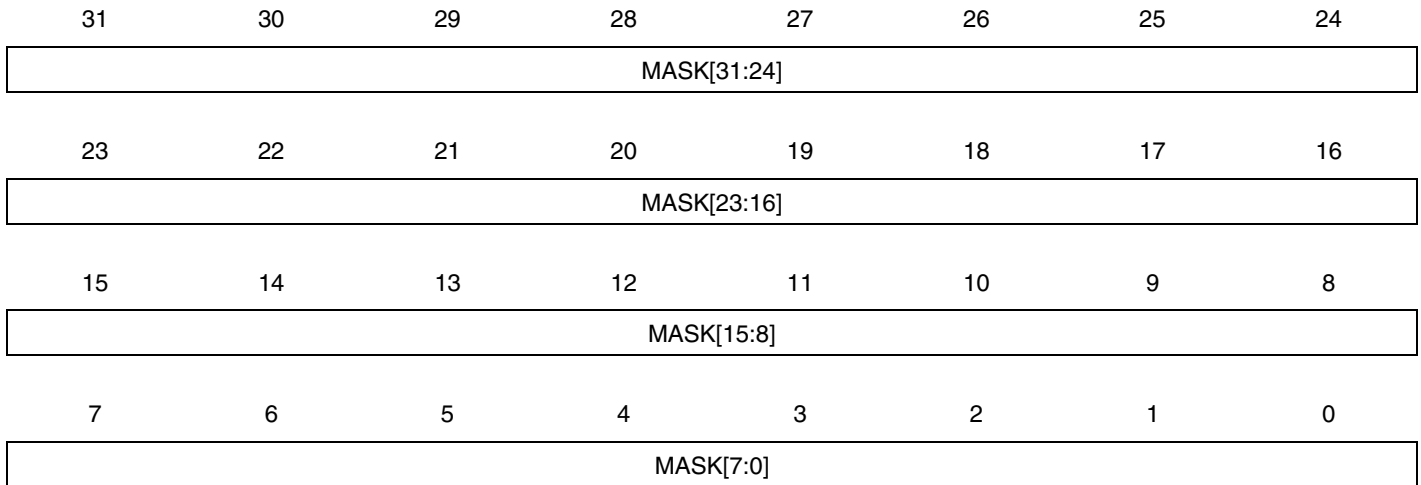

- **MASK: Clock Mask**

If bit n is cleared, the clock for module n is stopped. If bit n is set, the clock for module n is enabled according to the current power mode. The number of implemented bits in each mask register, as well as which module clock is controlled by each bit, is implementation dependent.

11.6.4 PLL Control

Name: PLL0,1

Access Type: Read/Write

31	30	29	28	27	26	25	24
PLLTEST	-	PLLCOUNT					
23	22	21	20	19	18	17	16
PLLMUL							
15	14	13	12	11	10	9	8
PLLDIV							
7	6	5	4	3	2	1	0
-	-	-	PLLOPT			PLLOSC	PLLEN

- **PLLTEST: PLL Test**

Reserved for internal use. Always write to 0.

- **PLLCOUNT: PLL Count**

Specifies the number of slow clock cycles before ISR:LOCKn will be set after PLLn has been written, or after PLLn has been automatically re-enabled after exiting a sleep mode.

- **PLLMUL: PLL Multiply Factor**

- **PLLDIV: PLL Division Factor**

These bitfields determine the ratio of the PLL output frequency to the source oscillator frequency:

$$f_{PLL} = (PLLMUL+1)/(PLLDIV+1) \cdot f_{OSC}$$

- **PLLOPT: PLL Option**

Select the operating range for the PLL. Note: Operation beyond the maximum clock speed is not implied.

100: 80-160 MHz

110: 150-200MHz

Other values: Reserved

- **PLLOSC: PLL Oscillator Select**

0: Oscillator 0 is the source for the PLL.

1: Oscillator 1 is the source for the PLL.

- **PLLOPT: PLL Option**

0: PLL is disabled.

1: PLL is enabled.

11.6.5 Interrupt Enable/Disable/Mask/Status/Clear

Name: IER/IDR/IMR/ISR/ICR

Access Type: IER/IDR/ICR: Write-only

IMR/ISR: Read-only

31	30	29	28	27	26	25	24
-	-	-	-	-	-	-	-
23	22	21	20	19	18	17	16
-	-	-	-	-	-	-	-
15	14	13	12	11	10	9	8
-	-	-	-	-	-	-	-
7	6	5	4	3	2	1	0
-	MSKRDY	CKRDY	VMRDY	VOK	WAKE	LOCK1	LOCK0

- **MSKRDY: Mask Ready**

0: Either xxxMASK register has been written, and clocks are not yet enabled or disabled according to the new mask value.

1: Clocks are enabled and disabled as indicated in the xxxMASK registers.

Note: Writing ICR:MSKRDY to 1 has no effect.

- **CKRDY: Clock Ready**

0: The CKSEL register has been written, and the new clock setting is not yet effective.

1: The synchronous clocks have frequencies as indicated in the CKSEL register.

Note: Writing ICR:CKRDY to 1 has no effect.

- **VMRDY, VOK**

These bits are for internal use only. In ISR, the value of these bits is undefined. In IER, these bits should be written to 0.

- **WAKE: Wake Pin Asserted**

0: The WAKE_N pin is not asserted, or has been asserted for less than one PB clock period.

1: The WAKE_N pin is asserted for longer than one PB clock period.

- **LOCK1: PLL1 locked**

- **LOCK0: PLL0 locked**

0: The PLL is unlocked, and cannot be used as clock source.

1: The PLL is locked, and can be used as clock source.

The effect of writing or reading the bits listed above depends on which register is being accessed:

- **IER (Write-only)**

0: No effect

1: Enable Interrupt

- **IDR (Write-only)**

0: No effect

1: Disable Interrupt

- **IMR (Read-only)**
 - 0: Interrupt is disabled
 - 1: Interrupt is enabled
- **ISR (Read-only)**
 - 0: An interrupt event has occurred
 - 1: An interrupt even has not occurred
- **ICR (Write-only)**
 - 0: No effect
 - 1: Clear interrupt event

11.6.6 Generic Clock Control

Name: GCCTRL0... GCCTRL7

Access Type: Read/Write

31	30	29	28	27	26	25	24
-	-	-	-	-	-	-	-
23	22	21	20	19	18	17	16
-	-	-	-	-	-	-	-
15	14	13	12	11	10	9	8
DIV[7:0]							
7	6	5	4	3	2	1	0
-	-	-	DIVEN	-	CEN	PLLSEL	OSCSEL

There is one GCCTRL register per generic clock in the design.

- **DIV: Division Factor**
- **DIVEN: Divide Enable**
 - 0: The generic clock equals the undivided source clock.
 - 1: The generic clock equals the source clock divided by $2^{(DIV+1)}$.
- **CEN: Clock Enable**
 - 0: Clock is stopped.
 - 1: Clock is running.
- **PLLSEL: PLL Select**
 - 0: Oscillator is source for the generic clock.
 - 1: PLL is source for the generic clock.
- **OSCSEL: Oscillator Select**
 - 0: Oscillator (or PLL) 0 is source for the generic clock.
 - 1: Oscillator (or PLL) 1 is source for the generic clock.

11.6.7 Reset Cause

Name: RC_RCAUSE

Access Type: Read-only

31	30	29	28	27	26	25	24
-	-	-	-	-	-	-	-
23	22	21	20	19	18	17	16
-	-	-	-	-	-	-	-
15	14	13	12	11	10	9	8
-	-	-	-	-	-	-	-
7	6	5	4	3	2	1	0
-	-	-	NTAE	WDT	EXT	-	POR

- **NTAE: NanoTrace Access Error**

This bit is set if a reset occurred due to a NanoTrace access error.

- **WDT: Watchdog Timer**

This bit is set if a reset occurred due to a timeout of the Watchdog Timer.

- **EXT: External Reset**

This bit is set if a reset occurred due to assertion of the RESET_N pin.

- **POR: Power-On Detector**

This bit is set if a reset was caused by the Power-On Detector.

12. Real Time Counter

Rev: 1.0.1

12.1 Features

- 32-bit real-time counter with 16-bit prescaler
- Clocked from 32 kHz oscillator
- High resolution: Max count frequency 16KHz
- Long delays
 - Max timeout 272 years
- Extremely low power consumption
- Available in all sleep modes except Deepdown
- Optional wrap at max value
- Interrupt on wrap

12.2 Description

The Real Time Counter (RTC) enables periodic interrupts at long intervals, or accurate measurement of real-time sequences. The RTC is fed from a 16-bit prescaler, which is clocked from the 32 kHz oscillator. Any tapping of the prescaler can be selected as clock source for the RTC, enabling both high resolution and long timeouts. The prescaler cannot be written directly, but can be cleared by the user.

The RTC can generate an interrupt when the counter wraps around the top value of 0xFFFFFFFF. Optionally, the RTC can wrap at a lower value, producing accurate periodic interrupts.

12.3 Block Diagram

Figure 12-1. Real Time Counter module block diagram

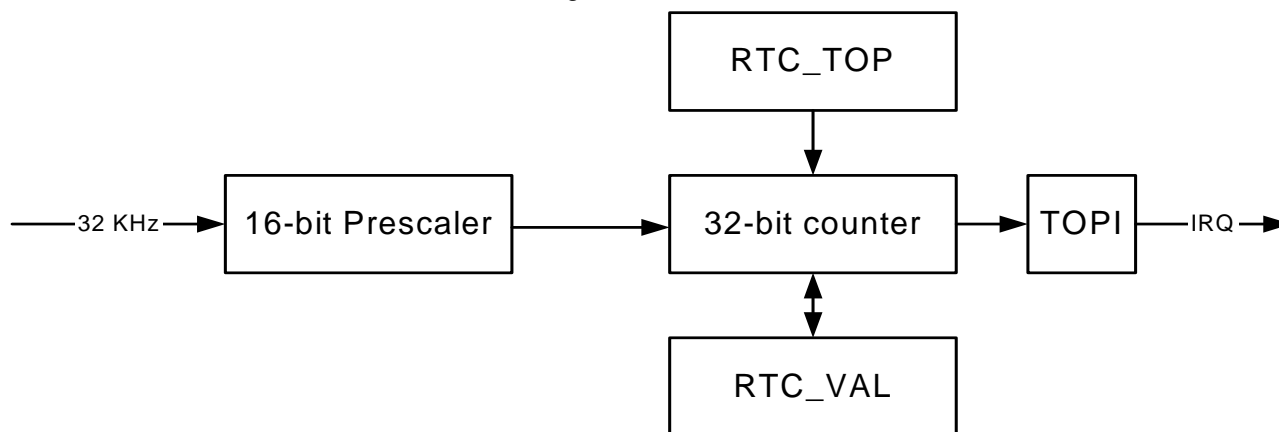

12.4 Product Dependencies

12.4.1 I/O Lines

none.

12.4.2 Power Management

The RTC is continuously clocked, and remains operating in all sleep modes except Deepdown.

12.4.3 Interrupt

The RTC interrupt line is connected to one of the internal sources of the interrupt controller. Using the RTC interrupt requires the interrupt controller to be programmed first.

12.4.4 Debug Operation

The RTC prescaler and watchdog timer are frozen during debug operation, unless the OCD system keeps peripherals running in debug operation.

12.5 Functional Description

12.5.1 RTC operation

12.5.1.1 Source clock

The RTC is enabled by writing the EN bit in the CTRL register. This also enables the clock for the prescaler. The PSEL bitfield in the same register selects the prescaler tapping, selecting the source clock for the RTC:

$$f_{\text{RTC}} = 2^{-(\text{PSEL}+1)} * 32\text{KHz}$$

12.5.1.2 Counter operation

The RTC count value can be read from or written to the register VAL. The prescaler cannot be written directly, but can be reset by writing the strobe PCLR in CTRL.

When enabled, the RTC will then up-count until it reaches 0xFFFFFFFF, and then wrap to 0x0.

Writing CTRL:TOPEN to one causes the RTC to wrap at the value written to TOP. The status bit TOPI in ISR is set when this occurs.

12.5.1.3 RTC Interrupt

Writing the TOPI bit in IER enables the RTC interrupt, while writing the corresponding bit in IDR disables the RTC interrupt. IMR can be read to see whether or not the interrupt is enabled. If enabled, an interrupt will be generated if the TOPI flag in ISR is set. The flag can be cleared by writing TOPI in ICR to one.

12.6 User Interface

Offset	Register	Register Name	Access	Reset
0x00	RTC Control	CTRL	Read/Write	0x0
0x04	RTC Value	VAL	Read/Write	0x0
0x08	RTC Top	TOP	Read/Write	0x0
0x10	RTC Interrupt Enable	IER	Write-only	0x0
0x14	RTC Interrupt Disable	IDR	Write-only	0x0
0x18	RTC Interrupt Mask	IMR	Read-only	0x0
0x1C	RTC Interrupt Status	ISR	Read-only	0x0
0x20	RTC Interrupt Clear	ICR	Write-only	0x0

12.6.1 RTC Control

Name: CTRL

Access Type: Read/Write

31	30	29	28	27	26	25	24
-	-	-	-	-	-	-	-
23	22	21	20	19	18	17	16
-	-	-	-	-	-	-	-
15	14	13	12	11	10	9	8
-	-	-	-	PSEL[3:0]			
7	6	5	4	3	2	1	0
-	-	-	-	-	TOPEN	PCLR	EN

- **PSEL: Prescale Select**

Selects prescaler bit PSEL as source clock for the RTC.

- **TOPEN: Top Enable**

0: RTC wraps at 0xFFFFFFFF

1: RTC wraps at RTC_TOP

- **PCLR: Prescaler Clear**

Writing this strobe clears the prescaler. Note that this also resets the watchdog timer.

- **EN: Enable**

0: RTC is disabled

1: RTC is enabled

12.6.2 RTC Value

Name: VAL

Access Type: Read/Write

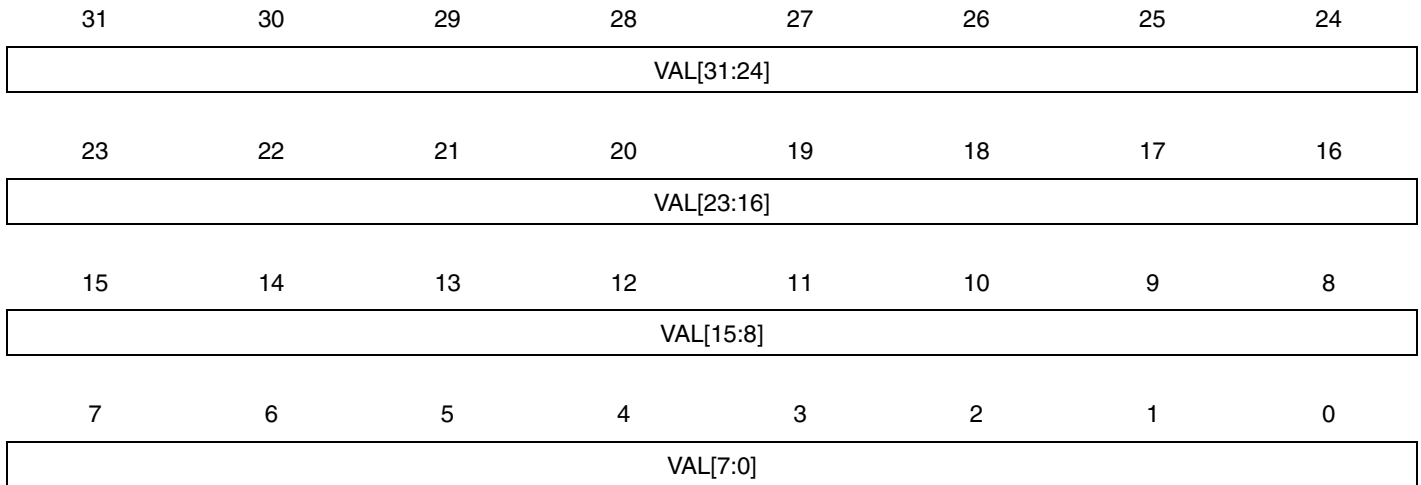

• VAL: RTC Value

This value is incremented on every rising edge of the source clock.

12.6.3 RTC Top

Name: TOP

Access Type: Read/Write

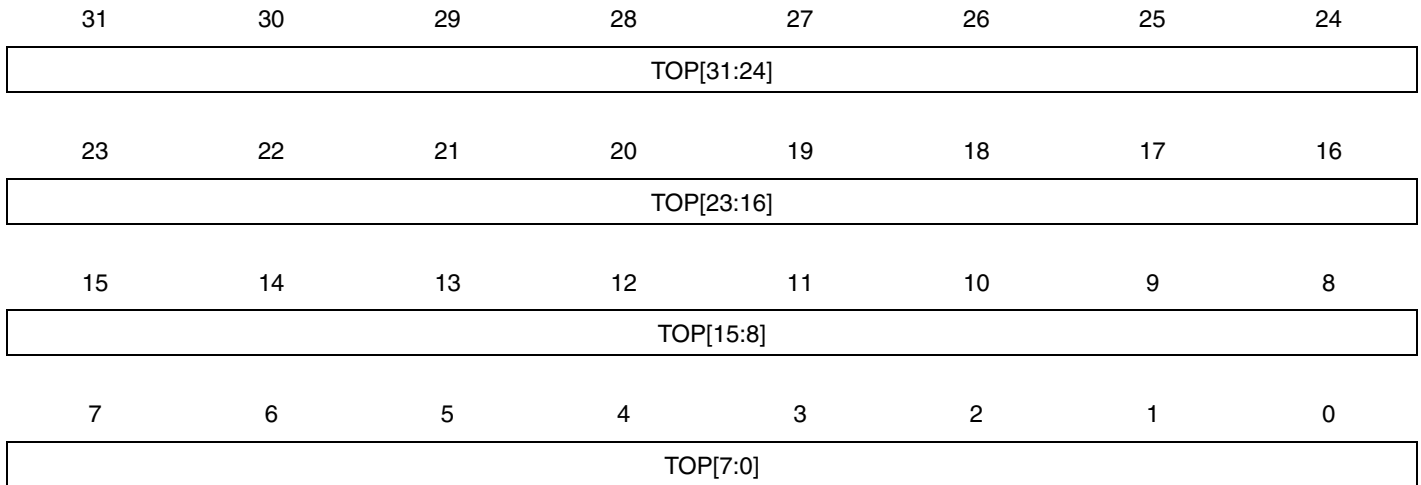

• TOP: RTC Top Value

VAL wraps at this value if CTRL:TOPEN is 1.

12.6.4 RTC Interrupt Enable/Disable/Mask/Status/Clear

Name: IER/IDR/IMR/ISR/ICR

Access Type: IER/IDR/ICR: Write-only

IMR/ISR: Read-only

31	30	29	28	27	26	25	24
-	-	-	-	-	-	-	-
23	22	21	20	19	18	17	16
-	-	-	-	-	-	-	-
15	14	13	12	11	10	9	8
-	-	-	-	-	-	-	-
7	6	5	4	3	2	1	0
-	-	-	-	-	-	-	TOPI

- **TOPI: Top Interrupt**

VAL has wrapped at its TOP.

The effect of writing or reading this bit depends on which register is being accessed:

- **IER (Write-only)**

0: No effect

1: Enable Interrupt

- **IDR (Write-only)**

0: No effect

1: Disable Interrupt

- **IMR (Read-only)**

0: Interrupt is disabled

1: Interrupt is enabled

- **ISR (Read-only)**

0: An interrupt event has not occurred

1: An interrupt event has occurred. Note that this is only set when the RTC is configured to wrap at TOP.

- **ICR (Write-only)**

0: No effect

1: Clear interrupt event

13. Watchdog Timer

Rev: 1.0.1

13.1 Features

- Watchdog timer with 16-bit prescaler

13.2 Description

The Watchdog Timer (WDT) is fed from a 16-bit prescaler, which is clocked from the 32 kHz oscillator. Any tapping of the prescaler can be selected as clock source for the WDT. The watchdog timer must be periodically reset by software within the timeout period, or otherwise, the device is reset and starts executing from the boot vector. This allows the device to recover from a condition that has caused the system to be unstable.

13.3 Block Diagram

Figure 13-1. Real Time Counter module block diagram

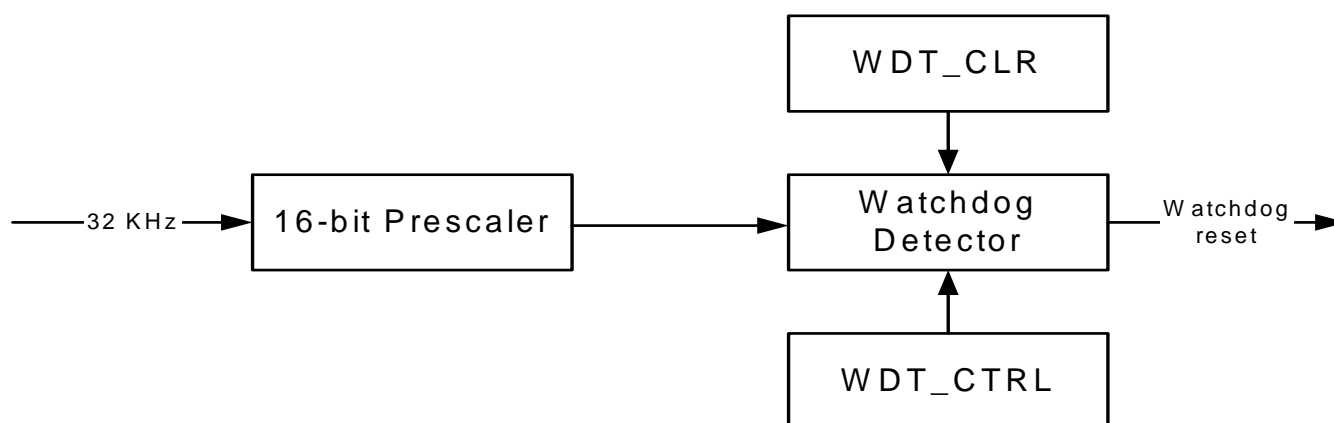

13.4 Product Dependencies

13.4.1 I/O Lines

None

13.4.2 Power Management

The WDT is continuously clocked, and remains operating in all sleep modes. However, if the WDT is enabled and the user tries to enter a sleepmode where the 32 KHz oscillator is turned off the system will enter the STOP sleepmode instead. This is to ensure the WDT is still running.

13.4.3 Debug Operation

The watchdog timer is frozen during debug operation, unless the OCD system keeps peripherals running in debug operation.

13.5 Functional Description

13.5.1 Watchdog Timer

The WDT is enabled by writing the EN bit in the CTRL register. This also enables the clock for the prescaler. The PSEL bitfield in the same register selects the watchdog timeout period:

$$T_{\text{WDT}} = 2^{(\text{PSEL}+1)} * 30.518\mu\text{s}$$

To avoid accidental disabling of the watchdog, the CTRL register must be written twice, first with the KEY field set to 0x55, then 0xAA without changing the other bitfields. Failure to do so will cause the write operation to be ignored, and CTRL does not change value.

The CLR register must be written with any value with regular intervals shorter than the watchdog timeout period. Otherwise, the device will receive a soft reset, and the code will start executing from the boot vector.

13.6 User Interface

Offset	Register	Register Name	Access	Reset
0x30	WDT Control	CTRL	Read/Write	0x0
0x34	WDT Clear	CLR	Write-only	0x0

13.6.1 WDT Control

Name: CTRL

Access Type: Read/Write

31	30	29	28	27	26	25	24
KEY[7:0]							
23	22	21	20	19	18	17	16
-	-	-	-	-	-	-	-
15	14	13	12	11	10	9	8
-	-	-	-	PSEL[3:0]			
7	6	5	4	3	2	1	0
-	-	-	-	-	-	-	EN

- **KEY**

This bitfield must be written twice, first with key value 0x55, then 0xAA, for a write operation to be effective. This bitfield always reads as zero.

- **PSEL: Prescale Select**

Prescaler bit PSEL is used as watchdog timeout period.

- **EN: WDT Enable**

0: WDT is disabled.

1: WDT is enabled.

13.6.2 WDT Clear**Name:** CLR**Access Type:** Write-only

When the watchdog timer is enabled, this register must be periodically written, with any value, within the watchdog timeout period, to prevent a watchdog reset.

14. Interrupt Controller

14.1 Description

The INTC collects interrupt requests from the peripherals, prioritizes them, and delivers an interrupt request and an autovector to the CPU. The AVR32 architecture supports 4 priority levels for regular, maskable interrupts, and a Non-Maskable Interrupt (NMI).

The INTC supports up to 64 groups of interrupts. Each group can have up to 32 interrupt request lines, these lines are connected to the peripherals. Each group has an Interrupt Priority Register (IPR) and an Interrupt Request Register (IRR). The IPRs are used to assign a priority level and an autovector to each group, and the IRRs are used to identify the active interrupt request within each group. If a group has only one interrupt request line, an active interrupt group uniquely identifies the active interrupt request line, and the corresponding IRR is not needed. The INTC also provides one Interrupt Cause Register (ICR) per priority level. These registers identify the group that has a pending interrupt of the corresponding priority level. If several groups have an pending interrupt of the same level, the group with the highest number takes priority.

14.2 Block Diagram

Figure 14-1 on page 124 gives an overview of the INTC. The grey boxes represent registers that can be accessed via the Peripheral Bus (PB). The interrupt requests from the peripherals (IREQn) and the NMI are input on the left side of the figure. Signals to and from the CPU are on the right side of the figure.

Figure 14-1. Overview of the Interrupt Controller

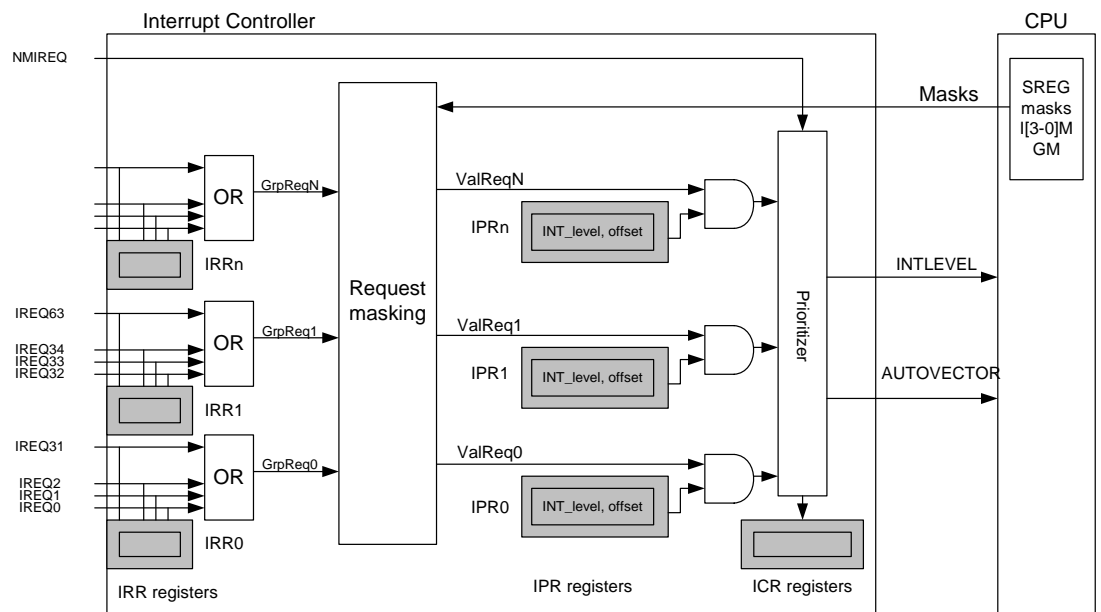

14.3 Operation

All of the incoming interrupt requests (IREQs) are sampled into the corresponding Interrupt Request Register (IRR). The IRRs must be accessed to identify which IREQ within a group that is active. If several IREQs within the same group is active, the interrupt service routine must prioritize between them. All of the input lines in each group are logically-ORed together to form the GrpReqN lines, indicating if there is a pending interrupt in the corresponding group.

The Request Masking hardware maps each of the GrpReq lines to a priority level from INT0 to INT3 by associating each group with the INTLEVEL field in the corresponding IPR register. The GrpReq inputs are then masked by the I0M, I1M, I2M, I3M and GM mask bits from the CPU status register. Any interrupt group that has a pending interrupt of a priority level that is not masked by the CPU status register, gets its corresponding ValReq line asserted.

The Prioritizer hardware uses the ValReq lines and the INTLEVEL field in the IPRs to select the pending interrupt of the highest priority. If a NMI interrupt is pending, it automatically gets highest priority of any pending interrupt. If several interrupt groups of the highest pending interrupt level have pending interrupts, the interrupt group with the highest number is selected.

Interrupt level (INTLEVEL) and handler autovector offset (AUTOVECTOR) of the selected interrupt are transmitted to the CPU for interrupt handling and context switching. The CPU doesn't need to know which interrupt is requesting handling, but only the level and the offset of the handler address. The IRR registers contain the interrupt request lines of the groups and can be read via PB for checking which interrupts of the group are actually active.

Masking of the interrupt requests is done based on five interrupt mask bits of the CPU status register, namely interrupt level 3 mask (I3M) to interrupt level 0 mask (I0M), and Global interrupt mask (GM). An interrupt request is masked if either the Global interrupt mask or the corresponding interrupt level mask bit is set.

14.3.1 Non maskable interrupts

A NMI request has priority over all other interrupt requests. NMI has a dedicated exception vector address defined by the AVR32 architecture, so AUTOVECTOR is undefined when INTLEVEL indicates that an NMI is pending.

14.3.2 CPU response

When the CPU receives an interrupt request it checks if any other exceptions are pending. If no exceptions of higher priority are pending, interrupt handling is initiated. When initiating interrupt handling, the corresponding interrupt mask bit is set automatically for this and lower levels in status register. E.g, if interrupt on level 3 is approved for handling the interrupt mask bits I3M, I2M, I1M, and I0M are set in status register. If interrupt on level 1 is approved the masking bits I1M, and I0M are set in status register. The handler offset is calculated from AUTOVECTOR and EVBA and a change-of-flow to this address is performed.

Setting of the interrupt mask bits prevents the interrupts from the same and lower levels to be passed through the interrupt controller. Setting of the same level mask bit prevents also multiple request of the same interrupt to happen.

It is the responsibility of the handler software to clear the interrupt request that caused the interrupt before returning from the interrupt handler. If the conditions that caused the interrupt are not cleared, the interrupt request remains active.

14.3.3 Clearing an interrupt request

Clearing of the interrupt request is done by writing to registers in the corresponding peripheral module, which then clears the corresponding NMIREQ/IREQ signal.

The recommended way of clearing an interrupt request is a store operation to the controlling peripheral register, followed by a dummy load operation from the same register. This causes a pipeline stall, which prevents the interrupt from accidentally re-triggering in case the handler is exited and the interrupt mask is cleared before the interrupt request is cleared.

14.4 User Interface

This chapter lists the INTC registers accessible through the PB bus. The registers are used to control the behaviour and read the status of the INTC.

14.4.1 Memory Map

The following table shows the address map of the INTC registers, relative to the base address of the INTC.

Table 14-1. INTC address map

Offset	Register	Name	Access	Reset Value
0	Interrupt Priority Register 0	IPR0	Read/Write	0x0000_0000
4	Interrupt Priority Register 1	IPR1	Read/Write	0x0000_0000
...
252	Interrupt Priority Register 63	IPR63	Read/Write	0x0000_0000
256	Interrupt Request Register 0	IRR0	Read-only	N/A
260	Interrupt Request Register 1	IRR1	Read-only	N/A
...
508	Interrupt Request Register 63	IRR63	Read-only	N/A
512	Interrupt Cause Register 3	ICR3	Read-only	N/A
516	Interrupt Cause Register 2	ICR2	Read-only	N/A
520	Interrupt Cause Register 1	ICR1	Read-only	N/A
524	Interrupt Cause Register 0	ICR0	Read-only	N/A

14.4.2 Interrupt Request Map

The mapping of interrupt requests from peripherals to INTREQs is presented in the Peripherals Section.

14.4.3 Interrupt Request Registers

Register Name: IRR0...IRR63

Access Type: Read-only

31	30	29	28	27	26	25	24
IRR(32*x+31)	IRR(32*x+30)	IRR(32*x+29)	IRR(32*x+28)	IRR(32*x+27)	IRR(32*x+26)	IRR(32*x+25)	IRR(32*x+24)
23	22	21	20	19	18	17	16
IRR(32*x+23)	IRR(32*x+22)	IRR(32*x+21)	IRR(32*x+20)	IRR(32*x+19)	IRR(32*x+18)	IRR(32*x+17)	IRR(32*x+16)
15	14	13	12	11	10	9	8
IRR(32*x+15)	IRR(32*x+14)	IRR(32*x+13)	IRR(32*x+12)	IRR(32*x+11)	IRR(32*x+10)	IRR(32*x+9)	IRR(32*x+8)
7	6	5	4	3	2	1	0
IRR(32*x+7)	IRR(32*x+6)	IRR(32*x+5)	IRR(32*x+4)	IRR(32*x+3)	IRR(32*x+2)	IRR(32*x+1)	IRR(32*x+0)

- **IRR: Interrupt Request line**

0 = No interrupt request is pending on this input request input.

1 = An interrupt request is pending on this input request input.

The are 64 IRRs, one for each group. Each IRR has 32 bits, one for each possible interrupt request, for a total of 2048 possible input lines. The IRRs are read by the software interrupt handler in order to determine which interrupt request is pending. The IRRs are sampled continuously, and are read-only.

14.4.4 Interrupt Priority Registers

Register Name: IPR0...IPR63

Access Type: Read/Write

31	30	29	28	27	26	25	24
INTLEVEL[1:0]		-	-	-	-	-	-
23	22	21	20	19	18	17	16
-	-	-	-	-	-	-	-
15	14	13	12	11	10	9	8
-	-	AUTOVECTOR[13:8]					
7	6	5	4	3	2	1	0
AUTOVECTOR[7:0]							

• **INTLEVEL: Interrupt level associated with this group**

Indicates the EVBA-relative offset of the interrupt handler of the corresponding group:

INTLEVEL[1:0]		Priority
0	0	INT0
0	1	INT1
1	0	INT2
1	1	INT3

• **AUTOVECTOR: Autovector address for this group**

Handler offset is used to give the address of the interrupt handler. The LSB should be written to zero to give halfword alignment

14.4.5 Interrupt Cause Registers

Register Name: ICR0...ICR3

Access Type: Read-only

31	30	29	28	27	26	25	24	
-	-	-	-	-	-	-	-	
23	22	21	20	19	18	17	16	
-	-	-	-	-	-	-	-	
15	14	13	12	11	10	9	8	
-	-	-	-	-	-	-	-	
7	6	5	4	3	2	1	0	
-	-	CAUSE						

• CAUSE: Interrupt group causing interrupt of priority n

ICRn identifies the group with the highest priority that has a pending interrupt of level n. If no interrupts of level n are pending, or the priority level is masked, the value of ICRn is UNDEFINED.

15. External Interrupts

Rev: 1.0.0

15.1 Features

- Dedicated interrupt requests for each interrupt
- Individually maskable interrupts
- Interrupt on rising or falling edge
- Interrupt on high or low level
- Maskable NMI interrupt

15.2 Description

The External Interrupt Module allows 4 pins to be configured as external interrupts. Each pin has its own interrupt request, and can be individually masked. Each pin can generate an interrupt on rising or falling edge, or high or low level.

The module also masks the NMI_N pin, which generates the NMI interrupt for the CPU.

15.3 Block Diagram

Figure 15-1. External Interrupt Module block diagram

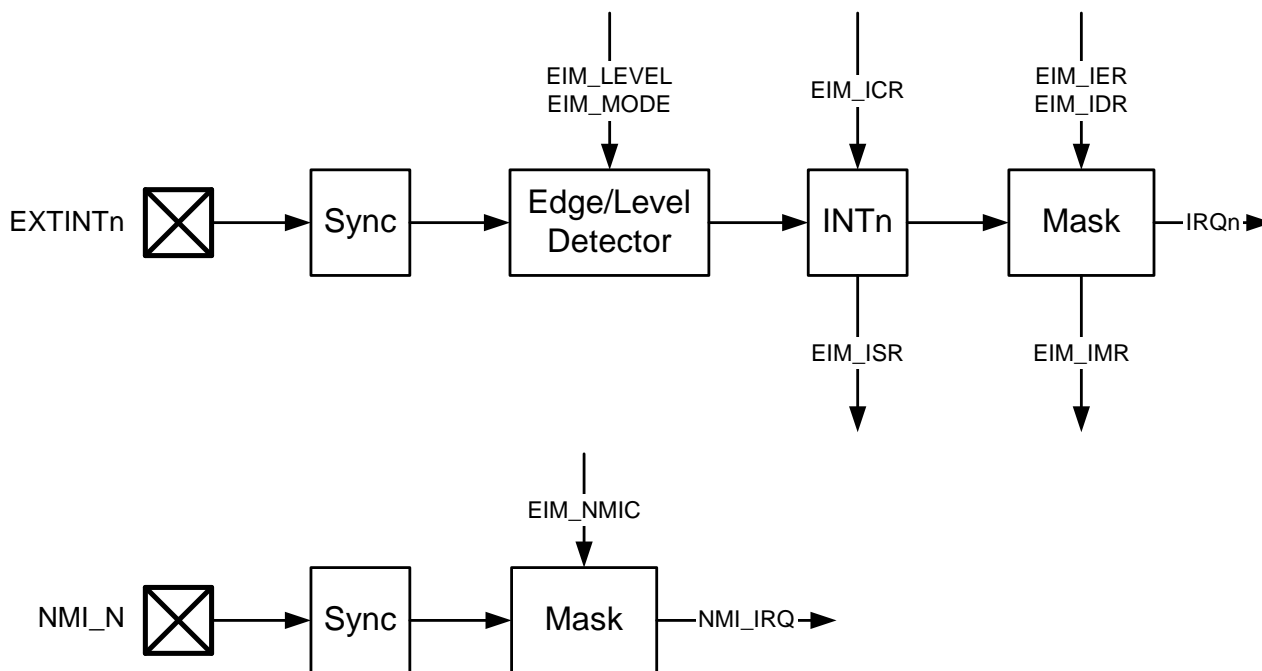

15.4 Product Dependencies

15.4.1 I/O Lines

The External Interrupt and NMI pins are multiplexed with PIO lines. To act as external interrupts, these pins must be configured as inputs pins by the PIO controller. It is also possible to trigger the interrupt by driving these pins from registers in the PIO controller, or another peripheral output connected to the same pin.

15.4.2 Power Management

Edge triggered interrupts are available in all sleep modes except Deepdown. Level triggered interrupts and the NMI interrupt are available in all sleep modes.

15.4.3 Interrupt

The EIM interrupt lines are connected to internal sources of the interrupt controller. Using the External Interrupts requires the interrupt controller to be programmed first.

Using the Non-Maskable Interrupt does not require the interrupt controller to be programmed.

15.5 Functional Description

15.5.1 External Interrupts

Each external interrupt pin EXTINTn can be configured to produce an interrupt on rising or falling edge, or high or low level. External interrupts are configured by the EIM_MODE, EIM_EDGE, and EIM_LEVEL registers. Each interrupt n has a bit INTn in each of these registers.

Similarly, each interrupt has a corresponding bit in each of the interrupt control and status registers. Writing 1 to the INTn strobe in EIM_IER enables the external interrupt on pin EXTINTn, while writing 1 to INTn in EIM_IDR disables the external interrupt. EIM_IMR can be read to check which interrupts are enabled. When the interrupt triggers, the corresponding bit in EIM_ISR will be set. For edge triggered interrupts, the flag remains set until the corresponding strobe bit in EIM_ICR is written to 1. For level triggered interrupts, the flag remains set for as long as the interrupt condition is present on the pin.

Writing INTn in EIM_MODE to 0 enables edge triggered interrupts, while writing the bit to 1 enables level triggered interrupts.

If EXTINTn is configured as an edge triggered interrupt, writing INTn in EIM_EDGE to 0 will trigger the interrupt on falling edge, while writing the bit to 1 will trigger the interrupt on rising edge.

If EXTINTn is configured as a level triggered interrupt, writing INTn in EIM_LEVEL to 0 will trigger the interrupt on low level, while writing the bit to 1 will trigger the interrupt on high level.

15.5.1.1 Synchronization of external interrupts

The pin value of the EXTINTn pins is normally synchronized to the CPU clock, so spikes shorter than a CPU clock cycle are not guaranteed to produce an interrupt. In Stop mode, spikes shorter than a 32KHz clock cycle are not guaranteed to produce an interrupt. In Deepdown mode, only unsynchronized level interrupts remain active, and any short spike on this interrupt will wake up the device.

15.5.2 NMI Control

The Non-Maskable Interrupt of the CPU is connected to the NMI_N pin through masking logic in the External Interrupt Module. This masking ensures that the NMI will not trigger before the CPU has been set up to handle interrupts. Writing the EN bit in the EIM_NMIC register enables the NMI interrupt, while writing EN to 0 disables the NMI interrupt. When enabled, the interrupt triggers whenever the NMI_N pin is negated.

The NMI_N pin is synchronized the same way as external level interrupts.

15.6 User Interface

Offset	Register	Register Name	Access	Reset
0x00	EIM Interrupt Enable	EIM_IER	Write-only	0x0
0x04	EIM Interrupt Disable	EIM_IDR	Write-only	0x0
0x08	EIM Interrupt Mask	EIM_IMR	Read-only	0x0
0x0C	EIM Interrupt Status	EIM_ISR	Read-only	0x0
0x10	EIM Interrupt Clear	EIM_ICR	Write-only	0x0
0x14	External Interrupt Mode	EIM_MODE	Read/Write	0x0
0x18	External Interrupt Edge	EIM_EDGE	Read/Write	0x0
0x1C	External Interrupt Level	EIM_LEVEL	Read/Write	0x0
0x24	External Interrupt NMI Control	EIM_NMIC	Read/Write	0x0

15.6.1 EIM Interrupt Enable/Disable/Mask/Status/Clear

Name: EIM_IER/IDR/IMR/ISR/ICR

Access Type: EIM_IER/IDR/ICR: Write-only

EIM_IMR/ISR: Read-only

31	30	29	28	27	26	25	24
-	-	-	-	-	-	-	-
23	22	21	20	19	18	17	16
-	-	-	-	-	-	-	-
15	14	13	12	11	10	9	8
-	-	-	-	-	-	-	-
7	6	5	4	3	2	1	0
-	-	-	-	INT3	INT2	INT1	INT0

- **INTn: External Interrupt n**

0: External Interrupt has not triggered

1: External Interrupt has triggered

The effect of writing or reading the bits listed above depends on which register is being accessed:

- **IER (Write-only)**

0: No effect

1: Enable Interrupt

- **IDR (Write-only)**

0: No effect

1: Disable Interrupt

- **IMR (Read-only)**

0: Interrupt is disabled

1: Interrupt is enabled

- **ISR (Read-only)**

0: An interrupt event has occurred

1: An interrupt even has not occurred

- **ICR (Write-only)**

0: No effect

1: Clear interrupt event

15.6.2 External Interrupt Mode/Edge/Level

Name: EIM_MODE/EDGE/LEVEL

Access Type: Read/Write

31	30	29	28	27	26	25	24
-	-	-	-	-	-	-	-
23	22	21	20	19	18	17	16
-	-	-	-	-	-	-	-
15	14	13	12	11	10	9	8
-	-	-	-	-	-	-	-
7	6	5	4	3	2	1	0
-	-	-	-	INT3	INT2	INT1	INT0

- **INTn: External Interrupt n**

The bit interpretation is register specific:

- **EIM_MODE**
 - 0: Interrupt is edge triggered
 - 1: Interrupt is level triggered
- **EIM_EDGE**
 - 0: Interrupt triggers on falling edge
 - 1: Interrupt triggers on rising edge
- **EIM_LEVEL**
 - 0: Interrupt triggers on low level
 - 1: Interrupt triggers on high level

15.6.3 NMI Control

Name: EIM_NMIC

Access Type: Read/Write

31	30	29	28	27	26	25	24
-	-	-	-	-	-	-	-
23	22	21	20	19	18	17	16
-	-	-	-	-	-	-	-
15	14	13	12	11	10	9	8
-	-	-	-	-	-	-	-
7	6	5	4	3	2	1	0
-	-	-	-	-	-	-	EN

• EN: Enable

0: NMI disabled. Asserting the NMI pin does not generate an NMI request.

1: NMI enabled. Asserting the NMI pin generate an NMI request.

16. HSB Bus Matrix (HMATRIX)

Rev: 2.2.0.0

16.1 Features

- User Interface on peripheral bus
- Configurable Number of Masters (Up to sixteen)
- Configurable Number of Slaves (Up to sixteen)
- One Decoder for Each Master
- Three Different Memory Mappings for Each Master (Internal and External boot, Remap)
- One Remap Function for Each Master
- Programmable Arbitration for Each Slave
 - Round-Robin
 - Fixed Priority
- Programmable Default Master for Each Slave
 - No Default Master
 - Last Accessed Default Master
 - Fixed Default Master
- One Cycle Latency for the First Access of a Burst
- Zero Cycle Latency for Default Master
- One Special Function Register for Each Slave (Not dedicated)

16.2 Description

The Bus Matrix implements a multi-layer bus structure, that enables parallel access paths between multiple High Speed Bus (HSB) masters and slaves in a system, thus increasing the overall bandwidth. The Bus Matrix interconnects up to 16 HSB Masters to up to 16 HSB Slaves. The normal latency to connect a master to a slave is one cycle except for the default master of the accessed slave which is connected directly (zero cycle latency). The Bus Matrix provides 16 Special Function Registers (SFR) that allow the Bus Matrix to support application specific features.

16.3 Memory Mapping

The Bus Matrix provides one decoder for every HSB Master Interface. The decoder offers each HSB Master several memory mappings. In fact, depending on the product, each memory area may be assigned to several slaves. Booting at the same address while using different HSB slaves (i.e. external RAM, internal ROM or internal Flash, etc.) becomes possible.

The Bus Matrix user interface provides Master Remap Control Register (MRCR) that performs remap action for every master independently.

16.4 Special Bus Granting Mechanism

The Bus Matrix provides some speculative bus granting techniques in order to anticipate access requests from some masters. This mechanism reduces latency at first access of a burst or single transfer. This bus granting mechanism sets a different default master for every slave.

At the end of the current access, if no other request is pending, the slave remains connected to its associated default master. A slave can be associated with three kinds of default masters: no default master, last access master and fixed default master.

16.5 No Default Master

At the end of the current access, if no other request is pending, the slave is disconnected from all masters. No Default Master suits low-power mode.

16.6 Last Access Master

At the end of the current access, if no other request is pending, the slave remains connected to the last master that performed an access request.

16.7 Fixed Default Master

At the end of the current access, if no other request is pending, the slave connects to its fixed default master. Unlike last access master, the fixed master does not change unless the user modifies it by a software action (field `FIXED_DEFMSTR` of the related `SCFG`).

To change from one kind of default master to another, the Bus Matrix user interface provides the Slave Configuration Registers, one for each slave, that set a default master for each slave. The Slave Configuration Register contains two fields: `DEFMSTR_TYPE` and `FIXED_DEFMSTR`. The 2-bit `DEFMSTR_TYPE` field selects the default master type (no default, last access master, fixed default master), whereas the 4-bit `FIXED_DEFMSTR` field selects a fixed default master provided that `DEFMSTR_TYPE` is set to fixed default master. Please refer to the Bus Matrix user interface description.

16.8 Arbitration

The Bus Matrix provides an arbitration mechanism that reduces latency when conflict cases occur, i.e. when two or more masters try to access the same slave at the same time. One arbiter per HSB slave is provided, thus arbitrating each slave differently.

The Bus Matrix provides the user with the possibility of choosing between 2 arbitration types for each slave:

1. Round-Robin Arbitration (default)
2. Fixed Priority Arbitration

This choice is made via the field `ARBT` of the Slave Configuration Registers (`SCFG`).

Each algorithm may be complemented by selecting a default master configuration for each slave.

When a re-arbitration must be done, specific conditions apply. See [Section 16.8.1 "Arbitration Rules" on page 137](#).

16.8.1 Arbitration Rules

Each arbiter has the ability to arbitrate between two or more different master requests. In order to avoid burst breaking and also to provide the maximum throughput for slave interfaces, arbitration may only take place during the following cycles:

1. Idle Cycles: When a slave is not connected to any master or is connected to a master which is not currently accessing it.
2. Single Cycles: When a slave is currently doing a single access.
3. End of Burst Cycles: When the current cycle is the last cycle of a burst transfer. For defined length burst, predicted end of burst matches the size of the transfer but is managed differently for undefined length burst. See [Section "16.8.1.1" on page 138](#).

4. Slot Cycle Limit: When the slot cycle counter has reached the limit value indicating that the current master access is too long and must be broken. See Section “16.8.1.2” on page 138.

16.8.1.1 Undefined Length Burst Arbitration

In order to avoid long slave handling during undefined length bursts (INCR), the Bus Matrix provides specific logic in order to re-arbitrate before the end of the INCR transfer. A predicted end of burst is used as a defined length burst transfer and can be selected from among the following five possibilities:

1. Infinite: No predicted end of burst is generated and therefore INCR burst transfer will never be broken.
2. One beat bursts: Predicted end of burst is generated at each single transfer inside the INCP transfer.
3. Four beat bursts: Predicted end of burst is generated at the end of each four beat boundary inside INCR transfer.
4. Eight beat bursts: Predicted end of burst is generated at the end of each eight beat boundary inside INCR transfer.
5. Sixteen beat bursts: Predicted end of burst is generated at the end of each sixteen beat boundary inside INCR transfer.

This selection can be done through the field ULBT of the Master Configuration Registers (MCFG).

16.8.1.2 Slot Cycle Limit Arbitration

The Bus Matrix contains specific logic to break long accesses, such as very long bursts on a very slow slave (e.g., an external low speed memory). At the beginning of the burst access, a counter is loaded with the value previously written in the SLOT_CYCLE field of the related Slave Configuration Register (SCFG) and decreased at each clock cycle. When the counter reaches zero, the arbiter has the ability to re-arbitrate at the end of the current byte, half word or word transfer.

16.8.2 Round-Robin Arbitration

This algorithm allows the Bus Matrix arbiters to dispatch the requests from different masters to the same slave in a round-robin manner. If two or more master requests arise at the same time, the master with the lowest number is first serviced, then the others are serviced in a round-robin manner.

There are three round-robin algorithms implemented:

- Round-Robin arbitration without default master
- Round-Robin arbitration with last default master
- Round-Robin arbitration with fixed default master

16.8.2.1 Round-Robin Arbitration without Default Master

This is the main algorithm used by Bus Matrix arbiters. It allows the Bus Matrix to dispatch requests from different masters to the same slave in a pure round-robin manner. At the end of the current access, if no other request is pending, the slave is disconnected from all masters. This configuration incurs one latency cycle for the first access of a burst. Arbitration without default master can be used for masters that perform significant bursts.

16.8.2.2 *Round-Robin Arbitration with Last Default Master*

This is a biased round-robin algorithm used by Bus Matrix arbiters. It allows the Bus Matrix to remove the one latency cycle for the last master that accessed the slave. In fact, at the end of the current transfer, if no other master request is pending, the slave remains connected to the last master that performed the access. Other non privileged masters still get one latency cycle if they want to access the same slave. This technique can be used for masters that mainly perform single accesses.

16.8.2.3 *Round-Robin Arbitration with Fixed Default Master*

This is another biased round-robin algorithm. It allows the Bus Matrix arbiters to remove the one latency cycle for the fixed default master per slave. At the end of the current access, the slave remains connected to its fixed default master. Every request attempted by this fixed default master will not cause any latency whereas other non privileged masters will still get one latency cycle. This technique can be used for masters that mainly perform single accesses.

16.8.3 **Fixed Priority Arbitration**

This algorithm allows the Bus Matrix arbiters to dispatch the requests from different masters to the same slave by using the fixed priority defined by the user. If two or more master requests are active at the same time, the master with the highest priority number is serviced first. If two or more master requests with the same priority are active at the same time, the master with the highest number is serviced first.

For each slave, the priority of each master may be defined through the Priority Registers for Slaves (PRAS and PRBS).

16.9 HSB Generic Bus Matrix User Interface

Table 16-1. Register Mapping

Offset	Register	Name	Access	Reset Value
0x0000	Master Configuration Register 0	MCFG0	Read/Write	0x00000002
0x0004	Master Configuration Register 1	MCFG1	Read/Write	0x00000002
0x0008	Master Configuration Register 2	MCFG2	Read/Write	0x00000002
0x000C	Master Configuration Register 3	MCFG3	Read/Write	0x00000002
0x0010	Master Configuration Register 4	MCFG4	Read/Write	0x00000002
0x0014	Master Configuration Register 5	MCFG5	Read/Write	0x00000002
0x0018	Master Configuration Register 6	MCFG6	Read/Write	0x00000002
0x001C	Master Configuration Register 7	MCFG7	Read/Write	0x00000002
0x0020	Master Configuration Register 8	MCFG8	Read/Write	0x00000002
0x0024	Master Configuration Register 9	MCFG9	Read/Write	0x00000002
0x0028	Master Configuration Register 10	MCFG10	Read/Write	0x00000002
0x002C	Master Configuration Register 11	MCFG11	Read/Write	0x00000002
0x0030	Master Configuration Register 12	MCFG12	Read/Write	0x00000002
0x0034	Master Configuration Register 13	MCFG13	Read/Write	0x00000002
0x0038	Master Configuration Register 14	MCFG14	Read/Write	0x00000002
0x003C	Master Configuration Register 15	MCFG15	Read/Write	0x00000002
0x0040	Slave Configuration Register 0	SCFG0	Read/Write	0x00000010
0x0044	Slave Configuration Register 1	SCFG1	Read/Write	0x00000010
0x0048	Slave Configuration Register 2	SCFG2	Read/Write	0x00000010
0x004C	Slave Configuration Register 3	SCFG3	Read/Write	0x00000010
0x0050	Slave Configuration Register 4	SCFG4	Read/Write	0x00000010
0x0054	Slave Configuration Register 5	SCFG5	Read/Write	0x00000010
0x0058	Slave Configuration Register 6	SCFG6	Read/Write	0x00000010
0x005C	Slave Configuration Register 7	SCFG7	Read/Write	0x00000010
0x0060	Slave Configuration Register 8	SCFG8	Read/Write	0x00000010
0x0064	Slave Configuration Register 9	SCFG9	Read/Write	0x00000010
0x0068	Slave Configuration Register 10	SCFG10	Read/Write	0x00000010
0x006C	Slave Configuration Register 11	SCFG11	Read/Write	0x00000010
0x0070	Slave Configuration Register 12	SCFG12	Read/Write	0x00000010
0x0074	Slave Configuration Register 13	SCFG13	Read/Write	0x00000010
0x0078	Slave Configuration Register 14	SCFG14	Read/Write	0x00000010
0x007C	Slave Configuration Register 15	SCFG15	Read/Write	0x00000010
0x0080	Priority Register A for Slave 0	PRAS0	Read/Write	0x00000000
0x0084	Priority Register B for Slave 0	PRBS0	Read/Write	0x00000000
0x0088	Priority Register A for Slave 1	PRAS1	Read/Write	0x00000000

Table 16-1. Register Mapping (Continued)

Offset	Register	Name	Access	Reset Value
0x008C	Priority Register B for Slave 1	PRBS1	Read/Write	0x00000000
0x0090	Priority Register A for Slave 2	PRAS2	Read/Write	0x00000000
0x0094	Priority Register B for Slave 2	PRBS2	Read/Write	0x00000000
0x0098	Priority Register A for Slave 3	PRAS3	Read/Write	0x00000000
0x009C	Priority Register B for Slave 3	PRBS3	Read/Write	0x00000000
0x00A0	Priority Register A for Slave 4	PRAS4	Read/Write	0x00000000
0x00A4	Priority Register B for Slave 4	PRBS4	Read/Write	0x00000000
0x00A8	Priority Register A for Slave 5	PRAS5	Read/Write	0x00000000
0x00AC	Priority Register B for Slave 5	PRBS5	Read/Write	0x00000000
0x00B0	Priority Register A for Slave 6	PRAS6	Read/Write	0x00000000
0x00B4	Priority Register B for Slave 6	PRBS6	Read/Write	0x00000000
0x00B8	Priority Register A for Slave 7	PRAS7	Read/Write	0x00000000
0x00BC	Priority Register B for Slave 7	PRBS7	Read/Write	0x00000000
0x00C0	Priority Register A for Slave 8	PRAS8	Read/Write	0x00000000
0x00C4	Priority Register B for Slave 8	PRBS8	Read/Write	0x00000000
0x00C8	Priority Register A for Slave 9	PRAS9	Read/Write	0x00000000
0x00CC	Priority Register B for Slave 9	PRBS9	Read/Write	0x00000000
0x00D0	Priority Register A for Slave 10	PRAS10	Read/Write	0x00000000
0x00D4	Priority Register B for Slave 10	PRBS10	Read/Write	0x00000000
0x00D8	Priority Register A for Slave 11	PRAS11	Read/Write	0x00000000
0x00DC	Priority Register B for Slave 11	PRBS11	Read/Write	0x00000000
0x00E0	Priority Register A for Slave 12	PRAS12	Read/Write	0x00000000
0x00E4	Priority Register B for Slave 12	PRBS12	Read/Write	0x00000000
0x00E8	Priority Register A for Slave 13	PRAS13	Read/Write	0x00000000
0x00EC	Priority Register B for Slave 13	PRBS13	Read/Write	0x00000000
0x00F0	Priority Register A for Slave 14	PRAS14	Read/Write	0x00000000
0x00F4	Priority Register B for Slave 14	PRBS14	Read/Write	0x00000000
0x00F8	Priority Register A for Slave 15	PRAS15	Read/Write	0x00000000
0x00FC	Priority Register B for Slave 15	PRBS15	Read/Write	0x00000000
0x0100	Master Remap Control Register	MRCR	Read/Write	0x00000000
0x0104 - 0x010C	Reserved	–	–	–
0x0110	Special Function Register 0	SFR0	Read/Write	–
0x0114	Special Function Register 1	SFR1	Read/Write	–
0x0118	Special Function Register 2	SFR2	Read/Write	–
0x011C	Special Function Register 3	SFR3	Read/Write	–
0x0120	Special Function Register 4	SFR4	Read/Write	–

Table 16-1. Register Mapping (Continued)

Offset	Register	Name	Access	Reset Value
0x0124	Special Function Register 5	SFR5	Read/Write	–
0x0128	Special Function Register 6	SFR6	Read/Write	–
0x012C	Special Function Register 7	SFR7	Read/Write	–
0x0130	Special Function Register 8	SFR8	Read/Write	–
0x0134	Special Function Register 9	SFR9	Read/Write	–
0x0138	Special Function Register 10	SFR10	Read/Write	–
0x013C	Special Function Register 11	SFR11	Read/Write	–
0x0140	Special Function Register 12	SFR12	Read/Write	–
0x0144	Special Function Register 13	SFR13	Read/Write	–
0x0148	Special Function Register 14	SFR14	Read/Write	–
0x014C	Special Function Register 15	SFR15	Read/Write	–
0x0150 - 0x01F8	Reserved	–	–	–

16.10 Bus Matrix Master Configuration Registers

Register Name: MCFG0...MCFG15

Access Type: Read/Write

31	30	29	28	27	26	25	24
-	-	-	-	-	-	-	-
23	22	21	20	19	18	17	16
-	-	-	-	-	-	-	-
15	14	13	12	11	10	9	8
-	-	-	-	-	-	-	-
7	6	5	4	3	2	1	0
-	-	-	-	-	ULBT		

• **ULBT: Undefined Length Burst Type**

0: Infinite Length Burst

No predicted end of burst is generated and therefore INCR bursts coming from this master cannot be broken.

1: Single Access

The undefined length burst is treated as a succession of single accesses, allowing re-arbitration at each beat of the INCR burst.

2: Four Beat Burst

The undefined length burst is split into a four-beat burst, allowing re-arbitration at each four-beat burst end.

3: Eight Beat Burst

The undefined length burst is split into an eight-beat burst, allowing re-arbitration at each eight-beat burst end.

4: Sixteen Beat Burst

The undefined length burst is split into a sixteen-beat burst, allowing re-arbitration at each sixteen-beat burst end.

16.11 Bus Matrix Slave Configuration Registers

Register Name: SCFG0...SCFG15

Access Type: Read/Write

31	30	29	28	27	26	25	24
-	-	-	-	-	-	-	ARBT
23	22	21	20	19	18	17	16
-	-	FIXED_DEFMSTR				DEFMSTR_TYPE	
15	14	13	12	11	10	9	8
-	-	-	-	-	-	-	-
7	6	5	4	3	2	1	0
SLOT_CYCLE							

- **SLOT_CYCLE: Maximum Number of Allowed Cycles for a Burst**

When the SLOT_CYCLE limit is reached for a burst, it may be broken by another master trying to access this slave.

This limit has been placed to avoid locking a very slow slave when very long bursts are used.

This limit must not be very small. Unreasonably small values break every burst and the Bus Matrix arbitrates without performing any data transfer. 16 cycles is a reasonable value for SLOT_CYCLE.

- **DEFMSTR_TYPE: Default Master Type**

0: No Default Master

At the end of the current slave access, if no other master request is pending, the slave is disconnected from all masters.

This results in a one cycle latency for the first access of a burst transfer or for a single access.

1: Last Default Master

At the end of the current slave access, if no other master request is pending, the slave stays connected to the last master having accessed it.

This results in not having one cycle latency when the last master tries to access the slave again.

2: Fixed Default Master

At the end of the current slave access, if no other master request is pending, the slave connects to the fixed master the number that has been written in the FIXED_DEFMSTR field.

This results in not having one cycle latency when the fixed master tries to access the slave again.

- **FIXED_DEFMSTR: Fixed Default Master**

This is the number of the Default Master for this slave. Only used if DEFMSTR_TYPE is 2. Specifying the number of a master which is not connected to the selected slave is equivalent to setting DEFMSTR_TYPE to 0.

- **ARBT: Arbitration Type**

0: Round-Robin Arbitration

1: Fixed Priority Arbitration

16.12 Bus Matrix Priority Registers A For Slaves

Register Name: PRAS0...PRAS15

Access Type: Read/Write

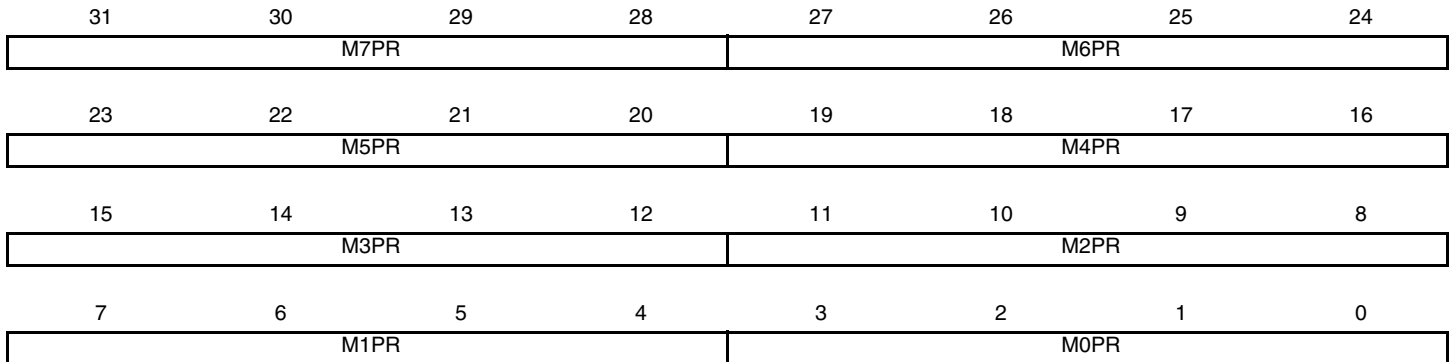

- **MxPR: Master x Priority**

Fixed priority of Master x for accessing the selected slave. The higher the number, the higher the priority.

16.13 Bus Matrix Priority Registers B For Slaves

Register Name: PRBS0...PRBS15

Access Type: Read/Write

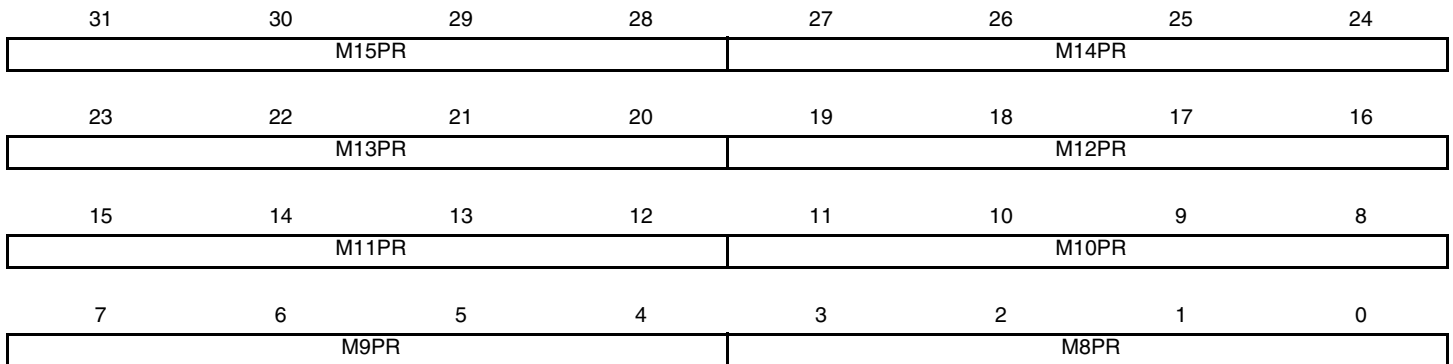

- **MxPR: Master x Priority**

Fixed priority of Master x for accessing the selected slave. The higher the number, the higher the priority.

16.14 Bus Matrix Master Remap Control Register

Register Name: MRCR

Access Type: Read/Write

Reset: 0x0000_0000

31	30	29	28	27	26	25	24
-	-	-	-	-	-	-	-
23	22	21	20	19	18	17	16
-	-	-	-	-	-	-	-
15	14	13	12	11	10	9	8
RCB15	RCB14	RCB13	RCB12	RCB11	RCB10	RCB9	RCB8
7	6	5	4	3	2	1	0
RCB7	RCB6	RCB5	RCB4	RCB3	RCB2	RCB1	RCB0

• **RCB: Remap Command Bit for Master x**

- 0: Disable remapped address decoding for the selected Master
- 1: Enable remapped address decoding for the selected Master

16.15 Bus Matrix Special Function Registers

Register Name: SFR0...SFR15

Access Type: Read/Write

Reset:

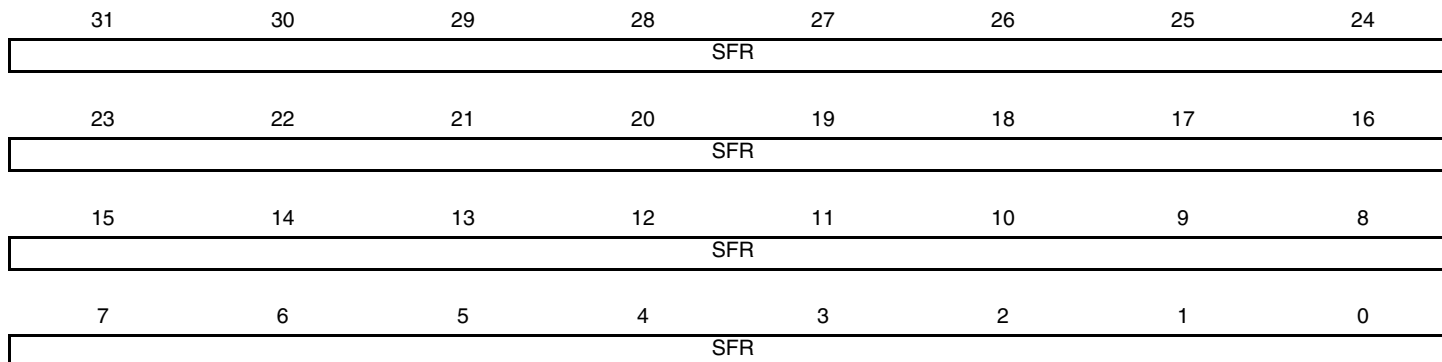

- **SFR: Special Function Register Fields**

The bitfields of these registers are described in the Peripherals chapter.

17. External Bus Interface (EBI)

Rev: 1.0.0

17.1 Features

- **Optimized for Application Memory Space support**
- **Integrates Three External Memory Controllers:**
 - Static Memory Controller
 - SDRAM Controller
 - ECC Controller
- **Additional Logic for NAND Flash/SmartMedia™ and CompactFlash™ Support**
 - SmartMedia support: 8-bit as well as 16-bit devices are supported
 - CompactFlash support: all modes (Attribute Memory, Common Memory, I/O, True IDE) are supported but the signals `_IOIS16` (I/O and True IDE modes) and `_ATA SEL` (True IDE mode) are not handled.
- **Optimized External Bus:**
 - 16- or 32-bit Data Bus
 - Up to 26-bit Address Bus, Up to 64-Mbytes Addressable
 - Optimized pin multiplexing to reduce latencies on External Memories
- **Up to 6 Chip Selects, Configurable Assignment:**
 - Static Memory Controller on NCS0
 - SDRAM Controller or Static Memory Controller on NCS1
 - Static Memory Controller on NCS2
 - Static Memory Controller on NCS3, Optional NAND Flash/SmartMedia™ Support
 - Static Memory Controller on NCS4 - NCS5, Optional CompactFlash™ Support

17.2 Description

The External Bus Interface (EBI) is designed to ensure the successful data transfer between several external devices and the embedded Memory Controller of an AVR32 device. The Static Memory, SDRAM and ECC Controllers are all featured external Memory Controllers on the EBI. These external Memory Controllers are capable of handling several types of external memory and peripheral devices, such as SRAM, PROM, EPROM, EEPROM, Flash, and SDRAM.

The EBI also supports the CompactFlash and the NAND Flash/SmartMedia protocols via integrated circuitry that greatly reduces the requirements for external components. Furthermore, the EBI handles data transfers with up to six external devices, each assigned to six address spaces defined by the embedded Memory Controller. Data transfers are performed through a 16-bit or 32-bit data bus, an address bus of up to 26 bits, up to six chip select lines (NCS[5:0]) and several control pins that are generally multiplexed between the different external Memory Controllers.

17.3 Block Diagram

17.3.1 External Bus Interface

Figure 17-1 shows the organization of the External Bus Interface.

Figure 17-1. Organization of the External Bus Interface

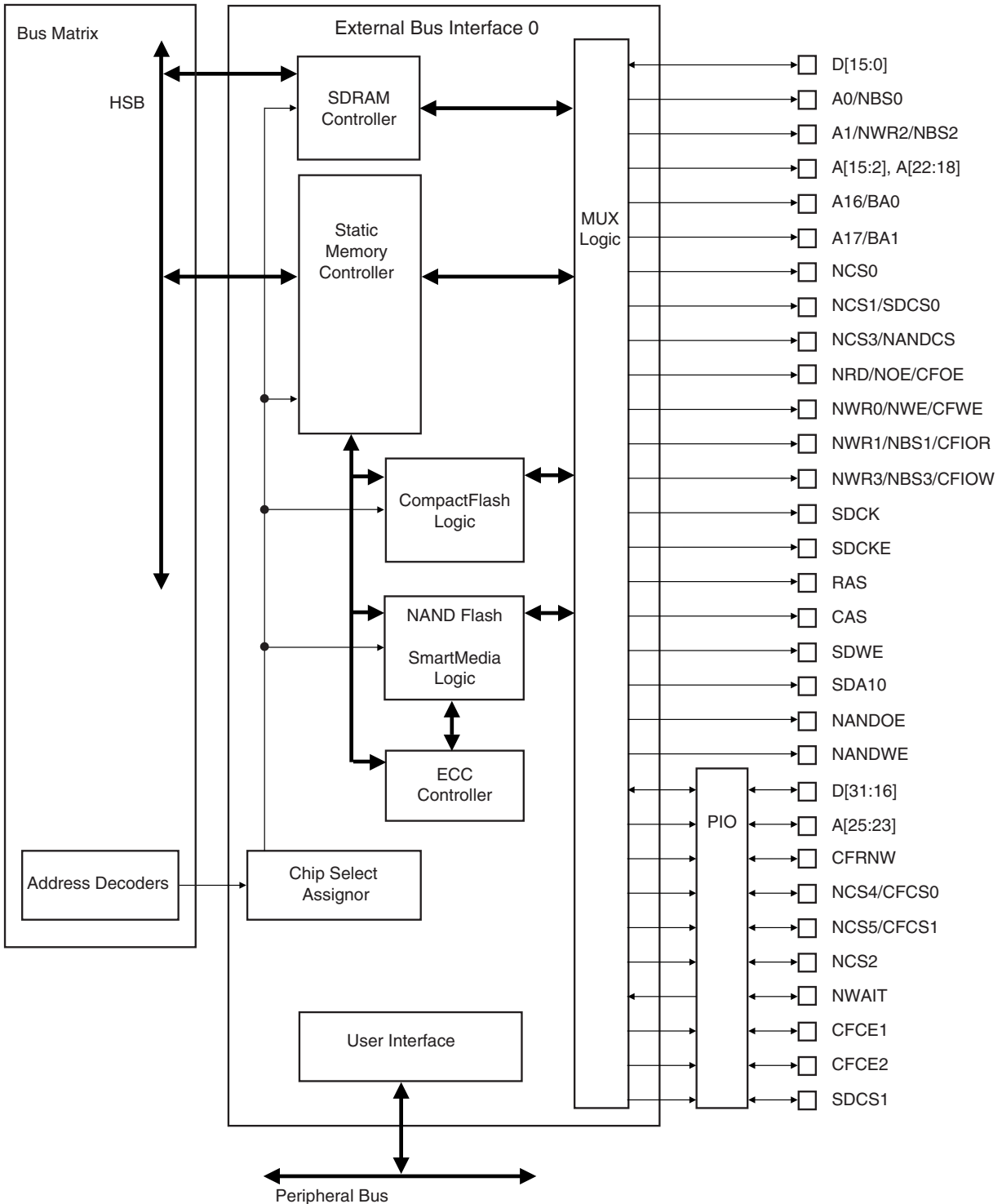

17.4 I/O Lines Description

Table 17-1. EBI I/O Lines Description

Name	Function	Type	Active Level
EBI			
D0 - D31	Data Bus	I/O	
A0 - A25	Address Bus	Output	
NWAIT	External Wait Signal	Input	Low
SMC			
NCS0 - NCS5	Chip Select Lines	Output	Low
NWR0 - NWR3	Write Signals	Output	Low
NOE	Output Enable	Output	Low
NRD	Read Signal	Output	Low
NWE	Write Enable	Output	Low
NBS0 - NBS3	Byte Mask Signals	Output	Low
EBI for CompactFlash Support			
CFCE1 - CFCE2	CompactFlash Chip Enable	Output	Low
CFOE	CompactFlash Output Enable	Output	Low
CFWE	CompactFlash Write Enable	Output	Low
CFIOR	CompactFlash I/O Read Signal	Output	Low
CFIOW	CompactFlash I/O Write Signal	Output	Low
CFRNW	CompactFlash Read Not Write Signal	Output	
CFCS0 - CFCS1	CompactFlash Chip Select Lines	Output	Low
EBI for NAND Flash/SmartMedia Support			
NANDCS	SmartMedia Chip Select Line	Output	Low
NANDOE	SmartMedia Output Enable	Output	Low
NANDWE	SmartMedia Write Enable	Output	Low
SDRAM Controller			
SDCK	SDRAM Clock	Output	
SDCKE	SDRAM Clock Enable	Output	High
SDCS	SDRAM Controller Chip Select Line	Output	Low
BA0 - BA1	Bank Select	Output	
SDWE	SDRAM Write Enable	Output	Low
RAS - CAS	Row and Column Signal	Output	Low
NWR0 - NWR3	Write Signals	Output	Low
NBS0 - NBS3	Byte Mask Signals	Output	Low
SDA10	SDRAM Address 10 Line	Output	

Depending on the Memory Controller in use, all signals are not connected directly through the Mux Logic.

[Table 17-2 on page 152](#) details the connections between the two Memory Controllers and the EBI pins.

Table 17-2. EBI Pins and Memory Controllers I/O Lines Connections

EBI Pins	SDRAMC I/O Lines	SMC I/O Lines
NWR1/NBS1/CFIOR	NBS1	NWR1/NUB
A0/NBS0	Not Supported	SMC_A0/NLB
A1/NBS2/NWR2	Not Supported	SMC_A1
A[11:2]	SDRAMC_A[9:0]	SMC_A[11:2]
SDA10	SDRAMC_A10	Not Supported
A12	Not Supported	SMC_A12
A[14:13]	SDRAMC_A[12:11]	SMC_A[14:13]
A[22:15]	Not Supported	SMC_A[22:15]
A[25:23]	Not Supported	SMC_A[25:23]
D[31:0]	D[31:0]	D[31:0]

17.5 Application Example

17.5.1 Hardware Interface

Table 17-3 on page 153 details the connections to be applied between the EBI pins and the external devices for each Memory Controller.

Table 17-3. EBI Pins and External Static Devices Connections

Signals	Pins of the Interfaced Device					
	8-bit Static Device	2 x 8-bit Static Devices	16-bit Static Device	4 x 8-bit Static Devices	2 x 16-bit Static Devices	32-bit Static Device
Controller	SMC					
D0 - D7	D0 - D7	D0 - D7	D0 - D7	D0 - D7	D0 - D7	D0 - D7
D8 - D15	–	D8 - D15	D8 - D15	D8 - D15	D8 - 15	D8 - 15
D16 - D23	–	–	–	D16 - D23	D16 - D23	D16 - D23
D24 - D31	–	–	–	D24 - D31	D24 - D31	D24 - D31
A0/NBS0	A0	–	NLB	–	NLB ⁽³⁾	BE0 ⁽⁵⁾
A1/NWR2/NBS2	A1	A0	A0	WE ⁽²⁾	NLB ⁽⁴⁾	BE2 ⁽⁵⁾
A2 - A22	A[2:22]	A[1:21]	A[1:21]	A[0:20]	A[0:20]	A[0:20]
A23 - A25	A[23:25]	A[22:24]	A[22:24]	A[21:23]	A[21:23]	A[21:23]
NCS0	CS	CS	CS	CS	CS	CS
NCS1/SDCS0	CS	CS	CS	CS	CS	CS
NCS2	CS	CS	CS	CS	CS	CS
NCS3/NANDCS	CS	CS	CS	CS	CS	CS
NCS4/CFCS0	CS	CS	CS	CS	CS	CS
NCS5/CFCS1	CS	CS	CS	CS	CS	CS
NRD/NOE/CFOE	OE	OE	OE	OE	OE	OE
NWR0/NWE	WE	WE ⁽¹⁾	WE	WE ⁽²⁾	WE	WE
NWR1/NBS1	–	WE ⁽¹⁾	NUB	WE ⁽²⁾	NUB ⁽³⁾	BE1 ⁽⁵⁾
NWR3/NBS3	–	–	–	WE ⁽²⁾	NUB ⁽⁴⁾	BE3 ⁽⁵⁾
SDSC1	–	–	–	–	–	CS

- Notes:
1. NWR1 enables upper byte writes. NWR0 enables lower byte writes.
 2. NWRx enables corresponding byte x writes. (x = 0,1,2 or 3)
 3. NBS0 and NBS1 enable respectively lower and upper bytes of the lower 16-bit word.
 4. NBS2 and NBS3 enable respectively lower and upper bytes of the upper 16-bit word.
 5. BEx: Byte x Enable (x = 0,1,2 or 3)

Table 17-4. EBI Pins and External Devices Connections

Signals	Pins of the Interfaced Device			
	SDRAM	Compact Flash	Compact Flash True IDE Mode	Smart Media or NAND Flash
Controller	SDRAMC	SMC		
D0 - D7	D0 - D7	D0 - D7	D0 - D7	AD0-AD7
D8 - D15	D8 - D15	D8 - 15	D8 - 15	AD8-AD15
D16 - D31	D16 - D31	–	–	–
A0/NBS0	DQM0	A0	A0	–
A1/NWR2/NBS2	DQM2	A1	A1	–
A2 - A10	A[0:8]	A[2:10]	A[2:10]	–
A11	A9	–	–	–
SDA10	A10	–	–	–
A12	–	–	–	–
A13 - A14	A[11:12]	–	–	–
A15	–	–	–	–
A16/BA0	BA0	–	–	–
A17/BA1	BA1	–	–	–
A18 - A20	–	–	–	–
A21	–	–	–	CLE ⁽³⁾
A22	–	REG	REG	ALE ⁽³⁾
A23 - A24	–	–	–	–
A25	–	–	–	–
NCS0	–	–	–	–
NCS1/SDCS0	CS[0]	–	–	–
NCS2	–	–	–	–
NCS2/NANDCS	–	–	–	–
NCS3/NANDCS	–	–	–	–
NCS4/CFCS0	–	CFCS0 ⁽¹⁾	CFCS0 ⁽¹⁾	–
NCS5/CFCS1	–	CFCS1 ⁽¹⁾	CFCS1 ⁽¹⁾	–
NANDOE	–	–	–	OE
NANDWE	–	–	–	WE
NRD/NOE/CFOE	–	OE	–	–
NWR0/NWE/CFWE	–	WE	WE	–
NWR1/NBS1/CFIOR	DQM1	IOR	IOR	–
NWR3/NBS3/CFIOW	DQM3	IOW	IOW	–
CFRNW	–	CFRNW ⁽¹⁾	CFRNW ⁽¹⁾	–
CFCE1	–	CE1	CS0	–

Table 17-4. EBI Pins and External Devices Connections (Continued)

Signals	Pins of the Interfaced Device			
	SDRAM	Compact Flash	Compact Flash True IDE Mode	Smart Media or NAND Flash
Controller	SDRAMC	SMC		
CFCE2	–	CE2	CS1	–
SDCK	CLK	–	–	–
SDCKE	CKE	–	–	–
RAS	RAS	–	–	–
CAS	CAS	–	–	–
SDWE	WE	–	–	–
NWAIT	–	WAIT	WAIT	–
Pxx ⁽²⁾	–	CD1 or CD2	CD1 or CD2	–
Pxx ⁽²⁾	–	–	–	CE
Pxx ⁽²⁾	–	–	–	RDY
SDCS1	CS[1]	–	–	–

- Note:
1. Not directly connected to the CompactFlash slot. Permits the control of the bidirectional buffer between the EBI data bus and the CompactFlash slot.
 2. Any PIO line.
 3. The CLE and ALE signals of the SmartMedia device may be driven by any address bit. For details, see ["SmartMedia and Nand Flash Support" on page 162](#).

17.5.2 Connection Examples

Figure 17-2 shows an example of connections between the EBI and external devices.

Figure 17-2. EBI Connections to Memory Devices

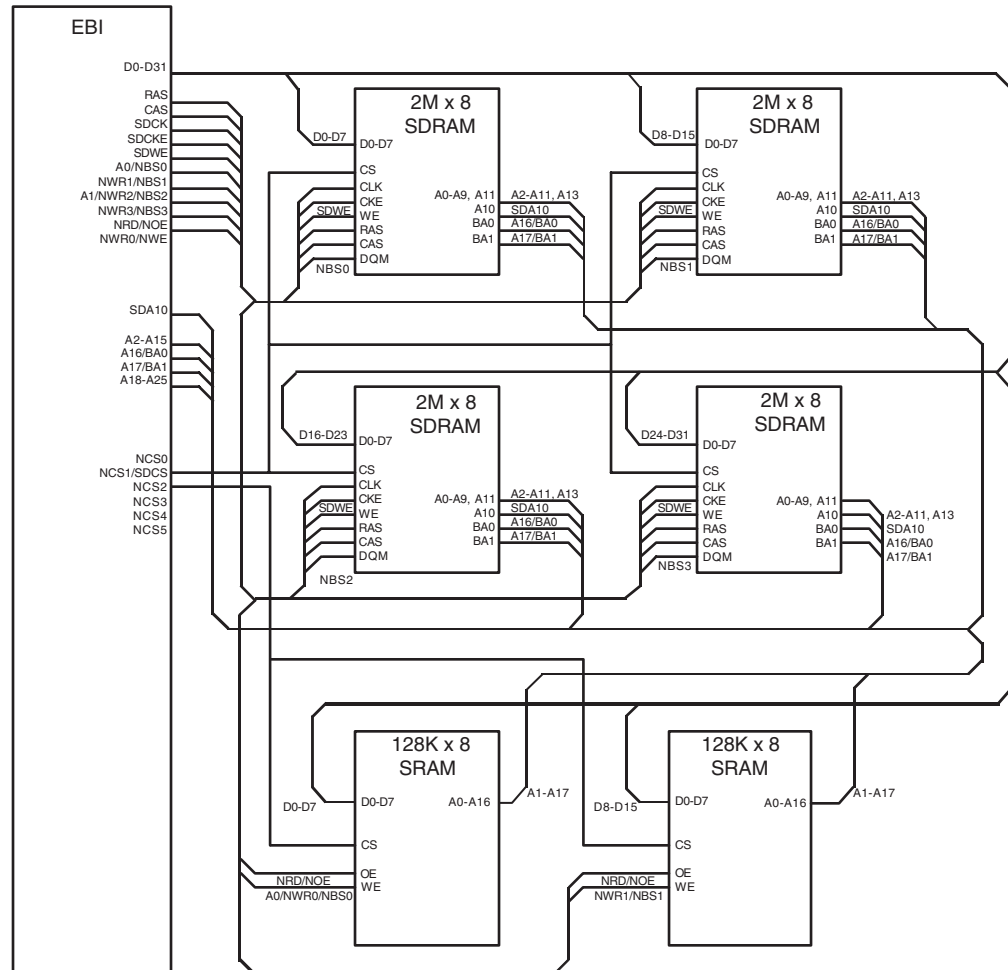

17.6 Product Dependencies

17.6.1 I/O Lines

The pins used for interfacing the External Bus Interface may be multiplexed with the PIO lines. The programmer must first program the PIO controller to assign the External Bus Interface pins to their peripheral function. If I/O lines of the External Bus Interface are not used by the application, they can be used for other purposes by the PIO Controller.

17.7 Functional Description

The EBI transfers data between the internal HSB Bus (handled by the HMatrix) and the external memories or peripheral devices. It controls the waveforms and the parameters of the external address, data and control busses and is composed of the following elements:

- The Static Memory Controller (SMC)
- The SDRAM Controller (SDRAMC)
- The ECC Controller (ECC)
- A chip select assignment feature that assigns an HSB address space to the external devices
- A multiplex controller circuit that shares the pins between the different Memory Controllers
- Programmable CompactFlash support logic
- Programmable SmartMedia and NAND Flash support logic

17.7.1 Bus Multiplexing

The EBI offers a complete set of control signals that share the 32-bit data lines, the address lines of up to 26 bits and the control signals through a multiplex logic operating in function of the memory area requests.

Multiplexing is specifically organized in order to guarantee the maintenance of the address and output control lines at a stable state while no external access is being performed. Multiplexing is also designed to respect the data float times defined in the Memory Controllers. Furthermore, refresh cycles of the SDRAM are executed independently by the SDRAM Controller without delaying the other external Memory Controller accesses.

17.7.2 Pull-up Control

A specific HMATRIX_SFR register in the Matrix User Interface permit enabling of on-chip pull-up resistors on the data bus lines not multiplexed with the PIO Controller lines. For details on this register, refer to the Peripherals Section. The pull-up resistors are enabled after reset. Setting the EBI_DBPUC bit disables the pull-up resistors on lines not muxed with PIO. Enabling the pull-up resistor on lines multiplexed with PIO lines can be performed by programming the appropriate PIO controller.

17.7.3 Static Memory Controller

For information on the Static Memory Controller, refer to the Static Memory Controller Section.

17.7.4 SDRAM Controller

For information on the SDRAM Controller, refer to the SDRAM Section.

17.7.5 ECC Controller

For information on the ECC Controller, refer to the ECC Section.

17.7.6 CompactFlash Support

The External Bus Interface integrates circuitry that interfaces to CompactFlash devices.

The CompactFlash logic is driven by the Static Memory Controller (SMC) on the NCS4 and/or NCS5 address space. Programming the EBI_CS4A and/or EBI_CS5A bits in a HMATRIX_SFR Register to the appropriate value enables this logic. For details on this register, refer to the Peripherals Section. Access to an external CompactFlash device is then made by accessing the address space reserved to NCS4 and/or NCS5 (i.e., between 0x2000 0000 and 0x23FF FFFF for NCS4 and between 0x0400 0000 and 0x07FF FFFF for NCS5).

All CompactFlash modes (Attribute Memory, Common Memory, I/O and True IDE) are supported but the signals _IOIS16 (I/O and True IDE modes) and _ATA SEL (True IDE mode) are not handled.

17.7.6.1 I/O Mode, Common Memory Mode, Attribute Memory Mode and True IDE Mode

Within the NCS4 and/or NCS5 address space, the current transfer address is used to distinguish I/O mode, common memory mode, attribute memory mode and True IDE mode.

The different modes are accessed through a specific memory mapping as illustrated on [Figure 17-3](#). A[23:21] bits of the transfer address are used to select the desired mode as described in [Table 17-5 on page 159](#).

Figure 17-3. CompactFlash Memory Mapping

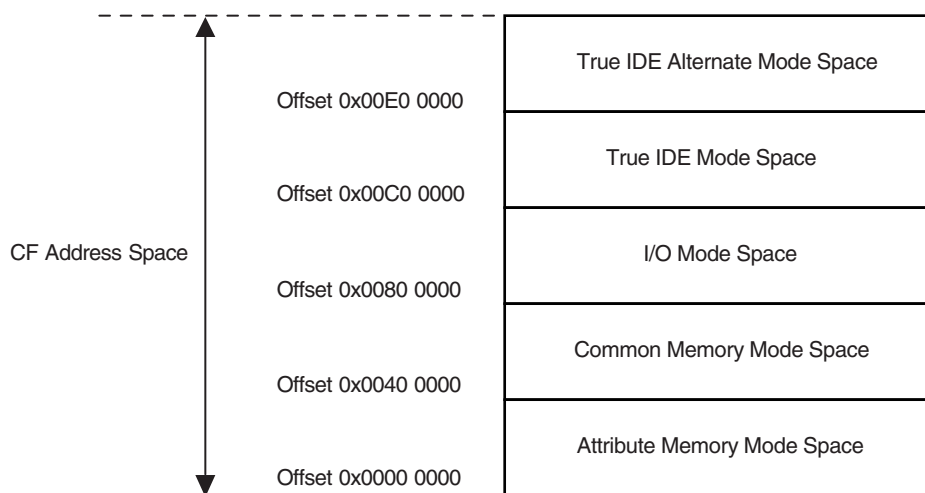

Note: The A22 pin is used to drive the REG signal of the CompactFlash Device (except in True IDE mode).

Table 17-5. CompactFlash Mode Selection

A[23:21]	Mode Base Address
000	Attribute Memory
010	Common Memory
100	I/O Mode
110	True IDE Mode
111	Alternate True IDE Mode

17.7.6.2 CFCE1 and CFCE2 signals

To cover all types of access, the SMC must be alternatively set to drive 8-bit data bus or 16-bit data bus. The odd byte access on the D[7:0] bus is only possible when the SMC is configured to drive 8-bit memory devices on the corresponding NCS pin (NCS4 or NCS5). The Chip Select Register (DBW field in the corresponding Chip Select Register) of the NCS4 and/or NCS5 address space must be set as shown in [Table 17-6](#) to enable the required access type.

NBS1 and NBS0 are the byte selection signals from SMC and are available when the SMC is set in Byte Select mode on the corresponding Chip Select.

The CFCE1 and CFCE2 waveforms are identical to the corresponding NCSx waveform. For details on these waveforms and timings, refer to the Static Memory Controller Section.

Table 17-6. CFCE1 and CFCE2 Truth Table

Mode	CFCE2	CFCE1	DBW	Comment	SMC Access Mode
Attribute Memory	NBS1	NBS0	16 bits	Access to Even Byte on D[7:0]	Byte Select
Common Memory	NBS1	NBS0	16bits	Access to Even Byte on D[7:0] Access to Odd Byte on D[15:8]	Byte Select
	1	0	8 bits	Access to Odd Byte on D[7:0]	
I/O Mode	NBS1	NBS0	16 bits	Access to Even Byte on D[7:0] Access to Odd Byte on D[15:8]	Byte Select
	1	0	8 bits	Access to Odd Byte on D[7:0]	
True IDE Mode					
Task File	1	0	8 bits	Access to Even Byte on D[7:0] Access to Odd Byte on D[7:0]	
Data Register	1	0	16 bits	Access to Even Byte on D[7:0] Access to Odd Byte on D[15:8]	Byte Select
Alternate True IDE Mode					
Control Register Alternate Status Read	0	1	Don't Care	Access to Even Byte on D[7:0]	Don't Care
Drive Address	0	1	8 bits	Access to Odd Byte on D[7:0]	
Standby Mode or Address Space is not assigned to CF	1	1	–	–	–

17.7.6.3 Read/Write Signals

In I/O mode and True IDE mode, the CompactFlash logic drives the read and write command signals of the SMC on CFIOR and CFIOW signals, while the CFOE and CFWE signals are deactivated. Likewise, in common memory mode and attribute memory mode, the SMC signals are driven on the CFOE and CFWE signals, while the CFIOR and CFIOW are deactivated. [Figure 17-4 on page 160](#) demonstrates a schematic representation of this logic.

Attribute memory mode, common memory mode and I/O mode are supported by setting the address setup and hold time on the NCS4 (and/or NCS5) chip select to the appropriate values. For details on these signal waveforms, please refer to the section: Setup and Hold Cycles of the Static Memory Controller Section.

Figure 17-4. CompactFlash Read/Write Control Signals

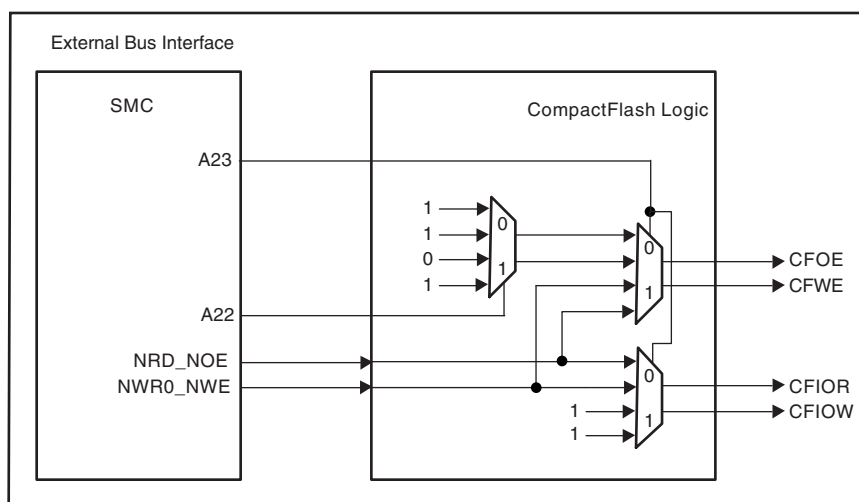

Table 17-7. CompactFlash Mode Selection

Mode Base Address	CFOE	CFWE	CFIOR	CFIOW
Attribute Memory Common Memory	NRD_NOE	NWR0_NWE	1	1
I/O Mode	1	1	NRD_NOE	NWR0_NWE
True IDE Mode	0	1	NRD_NOE	NWR0_NWE

17.7.6.4 Multiplexing of CompactFlash Signals on EBI Pins

[Table 17-8 on page 161](#) and [Table 17-9 on page 161](#) illustrate the multiplexing of the CompactFlash logic signals with other EBI signals on the EBI pins. The EBI pins in [Table 17-8](#) are strictly dedicated to the CompactFlash interface as soon as the EBI_CS4A and/or EBI_CS5A field of a specific HMATRIX_SFR Register is set, see the Peripherals Section for details. These pins must not be used to drive any other memory devices.

The EBI pins in [Table 17-9 on page 161](#) remain shared between all memory areas when the corresponding CompactFlash interface is enabled (EBI_CS4A = 1 and/or EBI_CS5A = 1).

Table 17-8. Dedicated CompactFlash Interface Multiplexing

Pins	CompactFlash Signals		EBI Signals	
	CS4A = 1	CS5A = 1	CS4A = 0	CS5A = 0
NCS4/CFCS0	CFCS0		NCS4	
NCS5/CFCS1		CFCS1		NCS5

Table 17-9. Shared CompactFlash Interface Multiplexing

Pins	Access to CompactFlash Device	Access to Other EBI Devices
	CompactFlash Signals	EBI Signals
NOE/NRD/CFOE	CFOE	NRD/NOE
NWR0/NWE/CFWE	CFWE	NWR0/NWE
NWR1/NBS1/CFIOR	CFIOR	NWR1/NBS1
NWR3/NBS3/CFIOW	CFIOW	NWR3/NBS3
A25/CFRNW	CFRNW	A25

17.7.6.5 Application Example

Figure 17-5 on page 162 illustrates an example of a CompactFlash application. CFCS0 and CFRNW signals are not directly connected to the CompactFlash slot 0, but do control the direction and the output enable of the buffers between the EBI and the CompactFlash Device. The timing of the CFCS0 signal is identical to the NCS4 signal. Moreover, the CFRNW signal remains valid throughout the transfer, as does the address bus. The CompactFlash _WAIT signal is connected to the NWAIT input of the Static Memory Controller. For details on these waveforms and timings, refer to the Static Memory Controller Section.

Figure 17-5. CompactFlash Application Example

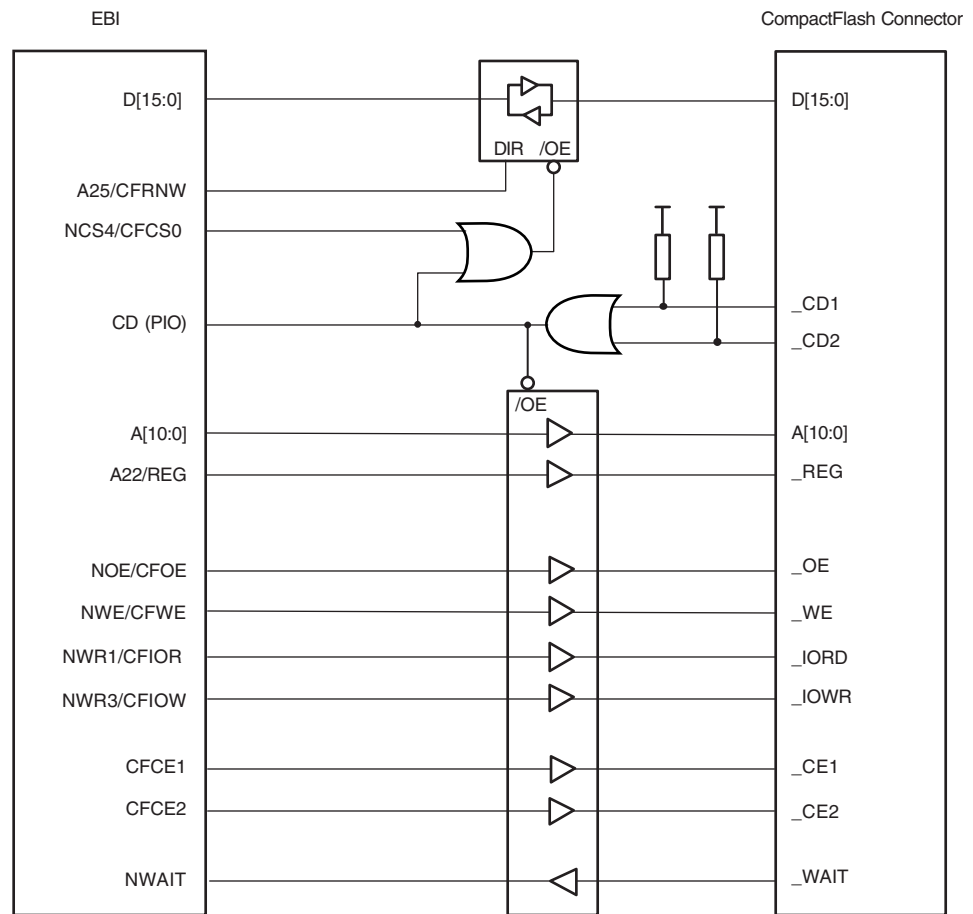

17.7.7 SmartMedia and Nand Flash Support

The External Bus Interface integrates circuitry that interfaces to SmartMedia and NAND Flash devices.

The SmartMedia logic is driven by the Static Memory Controller on the NCS3 address space. Programming the EBI_CS3A field in a specific HMATRIX_SFR Register to the appropriate value enables the SmartMedia logic. For details on this register, refer to the Peripherals Section. Access to an external SmartMedia device is then made by accessing the address space reserved to NCS3 (i.e., between 0x0C00 0000 and 0x0FFF FFFF).

The SmartMedia Logic drives the read and write command signals of the SMC on the NANDOE and NANDWE signals when the NCS3 signal is active. NANDOE and NANDWE are invalidated as soon as the transfer address fails to lie in the NCS3 address space. See Figure "SmartMedia Signal Multiplexing on EBI Pins" on page 163 for more informations. For details on these waveforms, refer to the Static Memory Controller Section.

Figure 17-6. SmartMedia Signal Multiplexing on EBI Pins

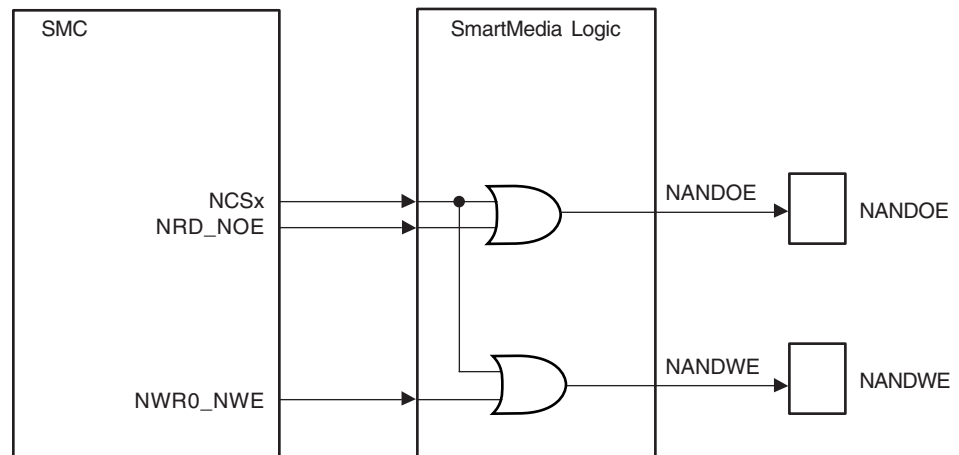

17.7.7.1 SmartMedia Signals

The address latch enable and command latch enable signals on the SmartMedia device are driven by address bits A22 and A21 of the EBI address bus. The user should note that any bit on the EBI address bus can also be used for this purpose. The command, address or data words on the data bus of the SmartMedia device are distinguished by using their address within the NCSx address space. The chip enable (CE) signal of the device and the ready/busy (R/B) signals are connected to PIO lines. The CE signal then remains asserted even when NCSx is not selected, preventing the device from returning to standby mode.

Figure 17-7. SmartMedia Application Example

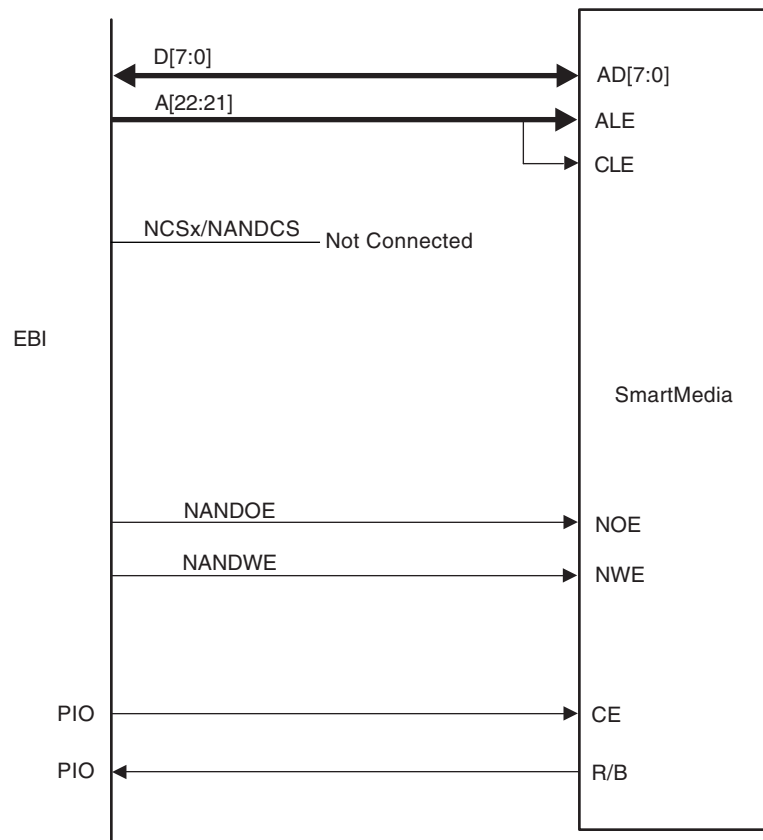

Note: The External Bus Interfaces is also able to support 16-bits devices.

18. DMA Controller (DMAC)

Rev: 2.06a.0

18.1 Features

- 2 HSB Master Interfaces
- 3 Channels
- Software and Hardware Handshaking Interfaces
 - 11 Hardware Handshaking Interfaces
- Memory/Non-Memory Peripherals to Memory/Non-Memory Peripherals Transfer
- Single-block DMA Transfer
- Multi-block DMA Transfer
 - Linked Lists
 - Auto-Reloading
 - Contiguous Blocks
- DMA Controller is Always the Flow Controller
- Additional Features
 - Scatter and Gather Operations
 - Channel Locking
 - Bus Locking
 - FIFO Mode
 - Pseudo Fly-by Operation

18.2 Description

The DMA Controller (DMAC) is an HSB-central DMA controller core that transfers data from a source peripheral to a destination peripheral over one or more System Bus. One channel is required for each source/destination pair. In the most basic configuration, the DMAC has one master interface and one channel. The master interface reads the data from a source and writes it to a destination. Two System Bus transfers are required for each DMA data transfer. This is also known as a dual-access transfer.

The DMAC is programmed via the HSB slave interface.

18.3 Block Diagram

Figure 18-1. DMA Controller (DMAC) Block Diagram

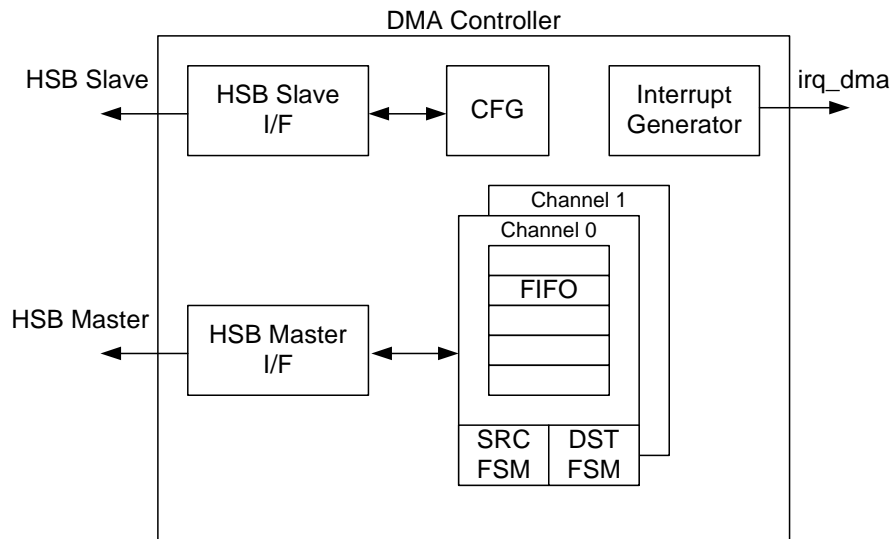

18.4 Functional Description

18.4.1 Basic Definitions

Source peripheral: Device on a System Bus layer from where the DMAC reads data, which is then stored in the channel FIFO. The source peripheral teams up with a destination peripheral to form a channel.

Destination peripheral: Device to which the DMAC writes the stored data from the FIFO (previously read from the source peripheral).

Memory: Source or destination that is always “ready” for a DMA transfer and does not require a handshaking interface to interact with the DMAC. A peripheral should be assigned as memory only if it does not insert more than 16 wait states. If more than 16 wait states are required, then the peripheral should use a handshaking interface (the default if the peripheral is not programmed to be memory) in order to signal when it is ready to accept or supply data.

Channel: Read/write datapath between a source peripheral on one configured System Bus layer and a destination peripheral on the same or different System Bus layer that occurs through the channel FIFO. If the source peripheral is not memory, then a source handshaking interface is assigned to the channel. If the destination peripheral is not memory, then a destination handshaking interface is assigned to the channel. Source and destination handshaking interfaces can be assigned dynamically by programming the channel registers.

Master interface: DMAC is a master on the HSB bus reading data from the source and writing it to the destination over the HSB bus.

Slave interface: The HSB interface over which the DMAC is programmed. The slave interface in practice could be on the same layer as any of the master interfaces or on a separate layer.

Handshaking interface: A set of signal registers that conform to a protocol and *handshake* between the DMAC and source or destination peripheral to control the transfer of a single or burst transaction between them. This interface is used to request, acknowledge, and control a

DMAC transaction. A channel can receive a request through one of three types of handshaking interface: hardware, software, or peripheral interrupt.

Hardware handshaking interface: Uses hardware signals to control the transfer of a single or burst transaction between the DMAC and the source or destination peripheral.

Software handshaking interface: Uses software registers to control the transfer of a single or burst transaction between the DMAC and the source or destination peripheral. No special DMAC handshaking signals are needed on the I/O of the peripheral. This mode is useful for interfacing an existing peripheral to the DMAC without modifying it.

Peripheral interrupt handshaking interface: A simple use of the hardware handshaking interface. In this mode, the interrupt line from the peripheral is tied to the dma_req input of the hardware handshaking interface. Other interface signals are ignored.

Flow controller: The device (either the DMAC or source/destination peripheral) that determines the length of and terminates a DMA block transfer. If the length of a block is known before enabling the channel, then the DMAC should be programmed as the flow controller. If the length of a block is not known prior to enabling the channel, the source or destination peripheral needs to terminate a block transfer. In this mode, the peripheral is the flow controller.

Flow control mode (CFGx.FCMODE): Special mode that only applies when the destination peripheral is the flow controller. It controls the pre-fetching of data from the source peripheral.

Transfer hierarchy: [Figure 18-2 on page 167](#) illustrates the hierarchy between DMAC transfers, block transfers, transactions (single or burst), and System Bus transfers (single or burst) for non-memory peripherals. [Figure 18-3 on page 168](#) shows the transfer hierarchy for memory.

Figure 18-2. DMAC Transfer Hierarchy for Non-Memory Peripheral

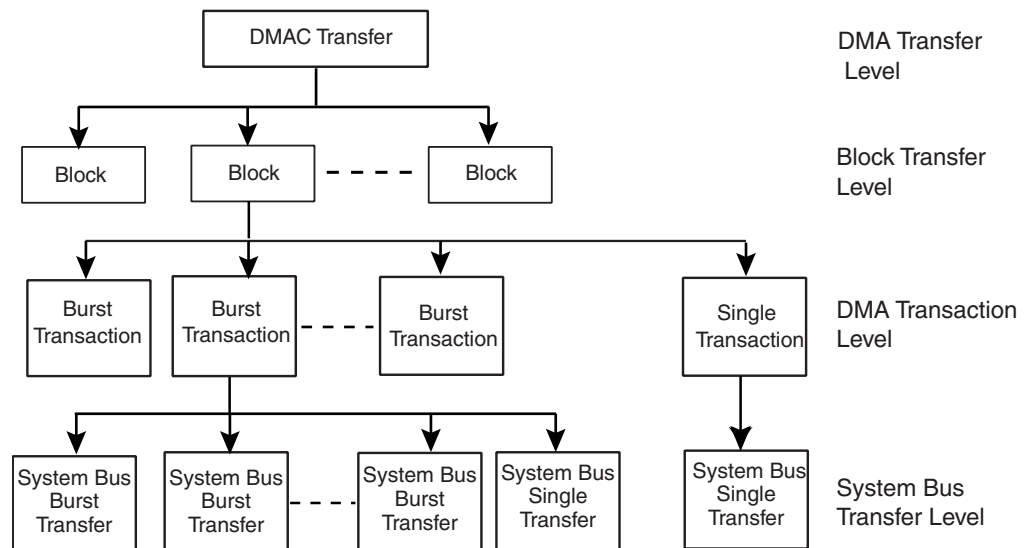
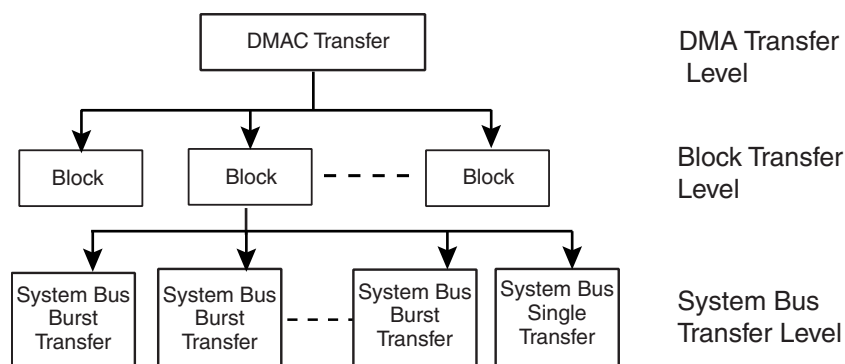

Figure 18-3. DMAC Transfer Hierarchy for Memory



Block: A block of DMAC data. The amount of data (block length) is determined by the flow controller. For transfers between the DMAC and memory, a block is broken directly into a sequence of System Bus bursts and single transfers. For transfers between the DMAC and a non-memory peripheral, a block is broken into a sequence of DMAC transactions (single and bursts). These are in turn broken into a sequence of System Bus transfers.

Transaction: A basic unit of a DMAC transfer as determined by either the hardware or software handshaking interface. A transaction is only relevant for transfers between the DMAC and a source or destination peripheral if the source or destination peripheral is a non-memory device. There are two types of transactions: single and burst.

- **Single transaction:** The length of a single transaction is always 1 and is converted to a single System Bus transfer.
- **Burst transaction:** The length of a burst transaction is programmed into the DMAC. The burst transaction is converted into a sequence of System Bus bursts and single transfers. DMAC executes each burst transfer by performing incremental bursts that are no longer than the maximum System Bus burst size set. The burst transaction length is under program control and normally bears some relationship to the FIFO sizes in the DMAC and in the source and destination peripherals.

DMA transfer: Software controls the number of blocks in a DMAC transfer. Once the DMA transfer has completed, then hardware within the DMAC disables the channel and can generate an interrupt to signal the completion of the DMA transfer. You can then re-program the channel for a new DMA transfer.

Single-block DMA transfer: Consists of a single block.

Multi-block DMA transfer: A DMA transfer may consist of multiple DMAC blocks. Multi-block DMA transfers are supported through block chaining (linked list pointers), auto-reloading of channel registers, and contiguous blocks. The source and destination can independently select which method to use.

- **Linked lists (block chaining)** – A linked list pointer (LLP) points to the location in system memory where the next linked list item (LLI) exists. The LLI is a set of registers that describe the next block (block descriptor) and an LLP register. The DMAC fetches the LLI at the beginning of every block when block chaining is enabled.
- **Auto-reloading** – The DMAC automatically reloads the channel registers at the end of each block to the value when the channel was first enabled.
- **Contiguous blocks** – Where the address between successive blocks is selected to be a continuation from the end of the previous block.

Scatter: Relevant to destination transfers within a block. The destination System Bus address is incremented/decremented by a programmed amount when a scatter boundary is reached. The number of System Bus transfers between successive scatter boundaries is under software control.

Gather: Relevant to source transfers within a block. The source System Bus address is incremented/decremented by a programmed amount when a gather boundary is reached. The number of System Bus transfers between successive gather boundaries is under software control.

Channel locking: Software can program a channel to keep the HSB master interface by locking the arbitration for the master bus interface for the duration of a DMA transfer, block, or transaction (single or burst).

Bus locking: Software can program a channel to maintain control of the System Bus bus by asserting hlock for the duration of a DMA transfer, block, or transaction (single or burst). Channel locking is asserted for the duration of bus locking at a minimum.

FIFO mode: Special mode to improve bandwidth. When enabled, the channel waits until the FIFO is less than half full to fetch the data from the source peripheral and waits until the FIFO is greater than or equal to half full to send data to the destination peripheral. Thus, the channel can transfer the data using System Bus bursts, eliminating the need to arbitrate for the HSB master interface for each single System Bus transfer. When this mode is not enabled, the channel only waits until the FIFO can transmit/accept a single System Bus transfer before requesting the master bus interface.

Pseudo fly-by operation: Typically, it takes two System Bus cycles to complete a transfer, one for reading the source and one for writing to the destination. However, when the source and destination peripherals of a DMA transfer are on different System Bus layers, it is possible for the DMAC to fetch data from the source and store it in the channel FIFO at the same time as the DMAC extracts data from the channel FIFO and writes it to the destination peripheral. This activity is known as *pseudo fly-by operation*. For this to occur, the master interface for both source and destination layers must win arbitration of their HSB layer. Similarly, the source and destination peripherals must win ownership of their respective master interfaces.

18.5 Memory Peripherals

Figure 18-3 on page 168 shows the DMA transfer hierarchy of the DMAC for a memory peripheral. There is no handshaking interface with the DMAC, and therefore the memory peripheral can never be a flow controller. Once the channel is enabled, the transfer proceeds immediately without waiting for a transaction request. The alternative to not having a transaction-level handshaking interface is to allow the DMAC to attempt System Bus transfers to the peripheral once the channel is enabled. If the peripheral slave cannot accept these System Bus transfers, it inserts wait states onto the bus until it is ready; it is not recommended that more than 16 wait states be inserted onto the bus. By using the handshaking interface, the peripheral can signal to the DMAC that it is ready to transmit/receive data, and then the DMAC can access the peripheral without the peripheral inserting wait states onto the bus.

18.6 Handshaking Interface

Handshaking interfaces are used at the transaction level to control the flow of single or burst transactions. The operation of the handshaking interface is different and depends on whether the peripheral or the DMAC is the flow controller.

The peripheral uses the handshaking interface to indicate to the DMAC that it is ready to transfer/accept data over the System Bus. A non-memory peripheral can request a DMA transfer through the DMAC using one of two handshaking interfaces:

- Hardware handshaking
- Software handshaking

Software selects between the hardware or software handshaking interface on a per-channel basis. Software handshaking is accomplished through memory-mapped registers, while hardware handshaking is accomplished using a dedicated handshaking interface.

18.6.1 Software Handshaking

When the slave peripheral requires the DMAC to perform a DMA transaction, it communicates this request by sending an interrupt to the CPU or interrupt controller.

The interrupt service routine then uses the software registers to initiate and control a DMA transaction. These software registers are used to implement the software handshaking interface.

The HS_SEL_SRC/HS_SEL_DST bit in the CFGx channel configuration register must be set to enable software handshaking.

When the peripheral is not the flow controller, then the last transaction registers LstSrcReg and LstDstReg are not used, and the values in these registers are ignored.

18.6.1.1 Burst Transactions

Writing a 1 to the ReqSrcReg[x]/ReqDstReg[x] register is always interpreted as a burst transaction request, where x is the channel number. However, in order for a burst transaction request to start, software must write a 1 to the SglReqSrcReg[x]/SglReqDstReg[x] register.

You can write a 1 to the SglReqSrcReg[x]/SglReqDstReg[x] and ReqSrcReg[x]/ReqDstReg[x] registers in any order, but both registers must be asserted in order to initiate a burst transaction. Upon completion of the burst transaction, the hardware clears the SglReqSrcReg[x]/SglReqDstReg[x] and ReqSrcReg[x]/ReqDstReg[x] registers.

18.6.1.2 Single Transactions

Writing a 1 to the SglReqSrcReg/SglReqDstReg initiates a single transaction. Upon completion of the single transaction, both the SglReqSrcReg/SglReqDstReg and ReqSrcReg/ReqDstReg bits are cleared by hardware. Therefore, writing a 1 to the ReqSrcReg/ReqDstReg is ignored while a single transaction has been initiated, and the requested burst transaction is not serviced.

Again, writing a 1 to the ReqSrcReg/ReqDstReg register is always a burst transaction request. However, in order for a burst transaction request to start, the corresponding channel bit in the SglReqSrcReg/SglReqDstReg must be asserted. Therefore, to ensure that a burst transaction is serviced, you must write a 1 to the ReqSrcReg/ReqDstReg before writing a 1 to the SglReqSrcReg/SglReqDstReg register.

Software can poll the relevant channel bit in the SglReqSrcReg/ SglReqDstReg and ReqSrcReg/ReqDstReg registers. When both are 0, then either the requested burst or single transaction has completed. Alternatively, the IntSrcTran or IntDstTran interrupts can be enabled and unmasked in order to generate an interrupt when the requested source or destination transaction has completed.

Note: The transaction-complete interrupts are triggered when both single and burst transactions are complete. The same transaction-complete interrupt is used for both single and burst transactions.

18.6.2 Hardware Handshaking

There are 11 hardware handshaking interfaces between the DMAC and peripherals. Refer to the “Peripherals” chapter for the device-specific mapping of these interfaces.

18.6.2.1 External DMA Request Definition

When an external slave peripheral requires the DMAC to perform DMA transactions, it communicates its request by asserting the external nDMAREQx signal. This signal is resynchronized to ensure a proper functionality (see [”External DMA Request Timing” on page 172](#)).

The external nDMAREQx is asserted when the source threshold level is reached. After resynchronization, the rising edge of dma_req starts the transfer. dma_req is de-asserted when dma_ack is asserted.

The external nDMAREQx signal must be de-asserted after the last transfer and re-asserted again before a new transaction starts.

For a source FIFO, an active edge is triggered on nDMAREQx when the source FIFO exceeds a watermark level. For a destination FIFO, an active edge is triggered on nDMAREQx when the destination FIFO drops below the watermark level.

The source transaction length, CTLx.SRC_MSIZEx, and destination transaction length, CTLx.DEST_MSIZEx, must be set according to watermark levels on the source/destination peripherals.

Figure 18-4. External DMA Request Timing

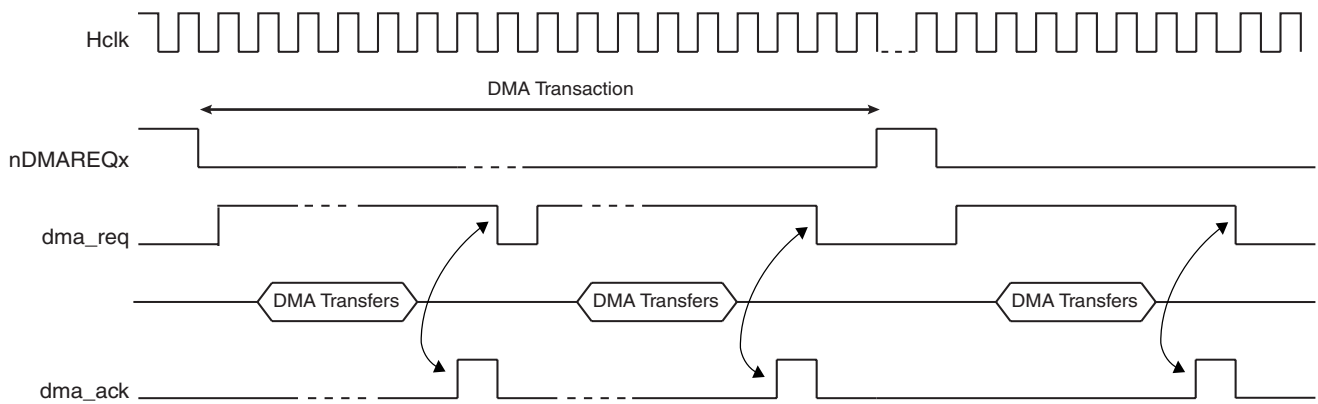

18.7 DMAC Transfer Types

A DMA transfer may consist of single or multi-block transfers. On successive blocks of a multi-block transfer, the SARx/DARx register in the DMAC is reprogrammed using either of the following methods:

- Block chaining using linked lists
- Auto-reloading
- Contiguous address between blocks

On successive blocks of a multi-block transfer, the CTLx register in the DMAC is re-programmed using either of the following methods:

- Block chaining using linked lists
- Auto-reloading

When block chaining, using linked lists is the multi-block method of choice, and on successive blocks, the LLPx register in the DMAC is re-programmed using the following method:

- Block chaining using linked lists

A block descriptor (LLI) consists of following registers, SARx, DARx, LLPx, CTL. These registers, along with the CFGx register, are used by the DMAC to set up and describe the block transfer.

18.7.1 Multi-block Transfers

18.7.1.1 *Block Chaining Using Linked Lists*

In this case, the DMAC re-programs the channel registers prior to the start of each block by fetching the block descriptor for that block from system memory. This is known as an LLI update.

DMAC block chaining is supported by using a Linked List Pointer register (LLPx) that stores the address in memory of the next linked list item. Each LLI (block descriptor) contains the corresponding block descriptor (SARx, DARx, LLPx, CTLx).

To set up block chaining, a sequence of linked lists must be programmed in memory.

The SARx, DARx, LLPx and CTLx registers are fetched from system memory on an LLI update. The updated contents of the CTLx register are written back to memory on block completion. [Figure 18-5 on page 174](#) shows how to use chained linked lists in memory to define multi-block transfers using block chaining.

The Linked List multi-block transfers is initiated by programming LLPx with LLPx(0) (LLI(0) base address) and CTLx with CTLx.LLP_S_EN and CTLx.LLP_D_EN.

Figure 18-5. Multi-block Transfer Using Linked Lists

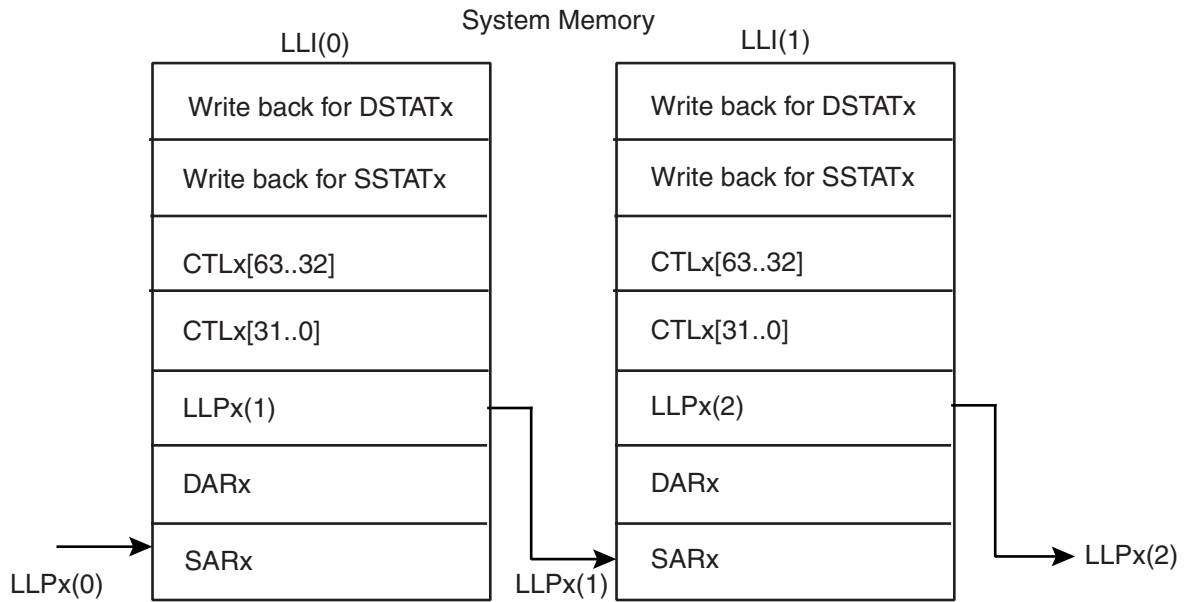

Table 18-1. Programming of Transfer Types and Channel Register Update Method (DMAC State Machine Table)

Transfer Type	LLP. LOC = 0	LLP_S_EN (CTLx)	RELOAD _SR (CFGx)	LLP_D_EN (CTLx)	RELOAD_ DS (CFGx)	CTLx, LLPx Update Method	SARx Update Method	DARx Update Method	Write Back
1) Single Block or last transfer of multi-Block	Yes	0	0	0	0	None, user reprograms	None (single)	None (single)	No
2) AutoReload multi-block transfer with contiguous SAR	Yes	0	0	0	1	CTLx,LLPx are reloaded from initial values.	Contiguous	Auto-Reload	No
3) AutoReload multi-block transfer with contiguous DAR	Yes	0	1	0	0	CTLx,LLPx are reloaded from initial values.	Auto-Reload	Con-tiguous	No
4) AutoReload multi-block transfer	Yes	0	1	0	1	CTLx,LLPx are reloaded from initial values.	Auto-Reload	Auto-Reload	No
5) Single Block or last transfer of multi-block	No	0	0	0	0	None, user reprograms	None (single)	None (single)	Yes
6) Linked List multi-block transfer with contiguous SAR	No	0	0	1	0	CTLx,LLPx loaded from next Linked List item	Contiguous	Linked List	Yes
7) Linked List multi-block transfer with auto-reload SAR	No	0	1	1	0	CTLx,LLPx loaded from next Linked List item	Auto-Reload	Linked List	Yes
8) Linked List multi-block transfer with contiguous DAR	No	1	0	0	0	CTLx,LLPx loaded from next Linked List item	Linked List	Con-tiguous	Yes
9) Linked List multi-block transfer with auto-reload DAR	No	1	0	0	1	CTLx,LLPx loaded from next Linked List item	Linked List	Auto-Reload	Yes
10) Linked List multi-block transfer	No	1	0	1	0	CTLx,LLPx loaded from next Linked List item	Linked List	Linked List	Yes

18.7.1.2 Auto-reloading of Channel Registers

During auto-reloading, the channel registers are reloaded with their initial values at the completion of each block and the new values used for the new block. Depending on the row number in [Table 18-1 on page 175](#), some or all of the SARx, DARx and CTLx channel registers are reloaded from their initial value at the start of a block transfer.

18.7.1.3 Contiguous Address Between Blocks

In this case, the address between successive blocks is selected to be a continuation from the end of the previous block. Enabling the source or destination address to be contiguous between blocks is a function of CTLx.LLP_S_EN, CFGx.RELOAD_SR, CTLx.LLP_D_EN, and CFGx.RELOAD_DS registers (see [Figure 18-1 on page 175](#)).

Note: Both SARx and DARx updates cannot be selected to be contiguous. If this functionality is required, the size of the Block Transfer (CTLx.BLOCK_TS) must be increased. If this is at the maximum value, use Row 10 of [Table 18-1 on page 175](#) and setup the LLI.SARx address of the block descriptor to be equal to the end SARx address of the previous block. Similarly, setup the LLI.DARx address of the block descriptor to be equal to the end DARx address of the previous block.

18.7.1.4 Suspension of Transfers Between Blocks

At the end of every block transfer, an end of block interrupt is asserted if:

- interrupts are enabled, CTLx.INT_EN = 1
- the channel block interrupt is unmasked, MaskBlock[n] = 0, where n is the channel number.

Note: The block complete interrupt is generated at the completion of the block transfer to the destination. For rows 6, 8, and 10 of [Table 18-1 on page 175](#), the DMA transfer does not stall between block transfers. For example, at the end of block N, the DMAC automatically proceeds to block N + 1.

For rows 2, 3, 4, 7, and 9 of [Table 18-1 on page 175](#) (SARx and/or DARx auto-reloaded between block transfers), the DMA transfer automatically stalls after the end of block. Interrupt is asserted if the end of block interrupt is enabled and unmasked.

The DMAC does not proceed to the next block transfer until a write to the block interrupt clear register, ClearBlock[n], is performed by software. This clears the channel block complete interrupt.

For rows 2, 3, 4, 7, and 9 of [Table 18-1 on page 175](#) (SARx and/or DARx auto-reloaded between block transfers), the DMA transfer does not stall if either:

- interrupts are disabled, CTLx.INT_EN = 0, or
- the channel block interrupt is masked, MaskBlock[n] = 1, where n is the channel number.

Channel suspension between blocks is used to ensure that the end of block ISR (interrupt service routine) of the next-to-last block is serviced before the start of the final block commences. This ensures that the ISR has cleared the CFGx.RELOAD_SR and/or CFGx.RELOAD_DS bits before completion of the final block. The reload bits CFGx.RELOAD_SR and/or CFGx.RELOAD_DS should be cleared in the 'end of block ISR' for the next-to-last block transfer.

18.7.2 Ending Multi-block Transfers

All multi-block transfers must end as shown in either Row 1 or Row 5 of [Table 18-1 on page 175](#). At the end of every block transfer, the DMAC samples the row number, and if the DMAC is in

Row 1 or Row 5 state, then the previous block transferred was the last block and the DMA transfer is terminated.

Note: Row 1 and Row 5 are used for single block transfers or terminating multiblock transfers. Ending in Row 5 state enables status fetch and writeback for the last block. Ending in Row 1 state disables status fetch and writeback for the last block.

For rows 2,3 and 4 of [Table 18-1 on page 175](#), (LLPx = 0 and CFGx.RELOAD_SR and/or CFGx.RELOAD_DS is set), multi-block DMA transfers continue until both the CFGx.RELOAD_SR and CFGx.RELOAD_DS registers are cleared by software. They should be programmed to zero in the end of block interrupt service routine that services the next-to-last block transfer. This puts the DMAC into Row 1 state.

For rows 6, 8, and 10 (both CFGx.RELOAD_SR and CFGx.RELOAD_DS cleared) the user must setup the last block descriptor in memory such that both LLI.CTLx.LLP_S_EN and LLI.CTLx.LLP_D_EN are zero. If the LLI.LLPx register of the last block descriptor in memory is non-zero, then the DMA transfer is terminated in Row 5. If the LLI.LLPx register of the last block descriptor in memory is zero, then the DMA transfer is terminated in Row 1.

For rows 7 and 9, the end-of-block interrupt service routine that services the next-to-last block transfer should clear the CFGx.RELOAD_SR and CFGx.RELOAD_DS reload bits. The last block descriptor in memory should be set up so that both the LLI.CTLx.LLP_S_EN and LLI.CTLx.LLP_D_EN are zero. If the LLI.LLPx register of the last block descriptor in memory is non-zero, then the DMA transfer is terminated in Row 5. If the LLI.LLPx register of the last block descriptor in memory is zero, then the DMA transfer is terminated in Row 1.

Note: The only allowed transitions between the rows of [Table 18-1 on page 175](#) are from any row into row 1 or row 5. As already stated, a transition into row 1 or row 5 is used to terminate the DMA transfer. All other transitions between rows are not allowed. Software must ensure that illegal transitions between rows do not occur between blocks of a multi-block transfer. For example, if block N is in row 10 then the only allowed rows for block N + 1 are rows 10, 5 or 1.

18.8 Programming a Channel

Three registers, the LLPx, the CTLx and CFGx, need to be programmed to set up whether single or multi-block transfers take place, and which type of multi-block transfer is used. The different transfer types are shown in [Table 18-1 on page 175](#).

The “Update Method” column indicates where the values of SARx, DARx, CTLx, and LLPx are obtained for the next block transfer when multi-block DMAC transfers are enabled.

Note: In [Table 18-1 on page 175](#), all other combinations of LLPx.LOC = 0, CTLx.LLP_S_EN, CFGx.RELOAD_SR, CTLx.LLP_D_EN, and CFGx.RELOAD_DS are illegal, and causes indeterminate or erroneous behavior.

18.8.1 Programming Examples

18.8.1.1 Single-block Transfer (Row 1)

Row 5 in [Table 18-1 on page 175](#) is also a single block transfer with writeback of control and status information enabled at the end of the single block transfer.

1. Read the Channel Enable register to choose a free (disabled) channel.
2. Clear any pending interrupts on the channel from the previous DMA transfer by writing to the Interrupt Clear registers: ClearTfr, ClearBlock, ClearSrcTran, ClearDstTran, ClearErr. Reading the Interrupt Raw Status and Interrupt Status registers confirms that all interrupts have been cleared.
3. Program the following channel registers:

- a. Write the starting source address in the SARx register for channel x.
 - b. Write the starting destination address in the DARx register for channel x.
 - c. Program CTLx and CFGx according to Row 1 as shown in [Table 18-1 on page 175](#). Program the LLPx register with '0'.
 - d. Write the control information for the DMA transfer in the CTLx register for channel x. For example, in the register, you can program the following:
 - i. Set up the transfer type (memory or non-memory peripheral for source and destination) and flow control device by programming the TT_FC of the CTLx register.
 - ii. Set up the transfer characteristics, such as:
 - Transfer width for the source in the SRC_TR_WIDTH field.
 - Transfer width for the destination in the DST_TR_WIDTH field.
 - Source master layer in the SMS field where source resides.
 - Destination master layer in the DMS field where destination resides.
 - Incrementing/decrementing or fixed address for source in SINC field.
 - Incrementing/decrementing or fixed address for destination in DINC field.
 - e. Write the channel configuration information into the CFGx register for channel x.
 - i. Designate the handshaking interface type (hardware or software) for the source and destination peripherals. This is not required for memory. This step requires programming the HS_SEL_SRC/HS_SEL_DST bits, respectively. Writing a '0' activates the hardware handshaking interface to handle source/destination requests. Writing a '1' activates the software handshaking interface to handle source/destination requests.
 - ii. If the hardware handshaking interface is activated for the source or destination peripheral, assign a handshaking interface to the source and destination peripheral. This requires programming the SRC_PER and DEST_PER bits, respectively.
4. After the DMAC selected channel has been programmed, enable the channel by writing a '1' to the ChEnReg.CH_EN bit. Make sure that bit 0 of the DmaCfgReg register is enabled.
 5. Source and destination request single and burst DMA transactions to transfer the block of data (assuming non-memory peripherals). The DMAC acknowledges at the completion of every transaction (burst and single) in the block and carry out the block transfer.
 6. Once the transfer completes, hardware sets the interrupts and disables the channel. At this time you can either respond to the Block Complete or Transfer Complete interrupts, or poll for the Channel Enable (ChEnReg.CH_EN) bit until it is cleared by hardware, to detect when the transfer is complete.

18.8.1.2 Multi-block Transfer with Linked List for Source and Linked List for Destination (Row 10)

1. Read the Channel Enable register to choose a free (disabled) channel.
2. Set up the chain of Linked List Items (otherwise known as block descriptors) in memory. Write the control information in the LLI.CTLx register location of the block descriptor for each LLI in memory (see [Figure 18-5 on page 174](#)) for channel x. For example, in the register, you can program the following:
 - a. Set up the transfer type (memory or non-memory peripheral for source and destination) and flow control device by programming the TT_FC of the CTLx register.
 - b. Set up the transfer characteristics, such as:
 - i. Transfer width for the source in the SRC_TR_WIDTH field.

- ii. Transfer width for the destination in the DST_TR_WIDTH field.
 - iii. Source master layer in the SMS field where source resides.
 - iv. Destination master layer in the DMS field where destination resides.
 - v. Incrementing/decrementing or fixed address for source in SINC field.
 - vi. Incrementing/decrementing or fixed address for destination DINC field.
3. Write the channel configuration information into the CFGx register for channel x.
 - a. Designate the handshaking interface type (hardware or software) for the source and destination peripherals. This is not required for memory. This step requires programming the HS_SEL_SRC/HS_SEL_DST bits, respectively. Writing a '0' activates the hardware handshaking interface to handle source/destination requests for the specific channel. Writing a '1' activates the software handshaking interface to handle source/destination requests.
 - b. If the hardware handshaking interface is activated for the source or destination peripheral, assign the handshaking interface to the source and destination peripheral. This requires programming the SRC_PER and DEST_PER bits, respectively.
 4. Make sure that the LLI.CTLx register locations of all LLI entries in memory (except the last) are set as shown in Row 10 of [Table 18-1 on page 175](#). The LLI.CTLx register of the last Linked List Item must be set as described in Row 1 or Row 5 of [Table 18-1. Figure 18-7 on page 181](#) shows a Linked List example with two list items.
 5. Make sure that the LLI.LLPx register locations of all LLI entries in memory (except the last) are non-zero and point to the base address of the next Linked List Item.
 6. Make sure that the LLI.SARx/LLI.DARx register locations of all LLI entries in memory point to the start source/destination block address preceding that LLI fetch.
 7. Make sure that the LLI.CTLx.DONE field of the LLI.CTLx register locations of all LLI entries in memory are cleared.
 8. Clear any pending interrupts on the channel from the previous DMA transfer by writing to the Interrupt Clear registers: ClearTfr, ClearBlock, ClearSrcTran, ClearDstTran, ClearErr. Reading the Interrupt Raw Status and Interrupt Status registers confirms that all interrupts have been cleared.
 9. Program the CTLx, CFGx registers according to Row 10 as shown in [Table 18-1 on page 175](#).
 10. Program the LLPx register with LLPx(0), the pointer to the first Linked List item.
 11. Finally, enable the channel by writing a '1' to the ChEnReg.CH_EN bit. The transfer is performed.
 12. The DMAC fetches the first LLI from the location pointed to by LLPx(0).
- Note: The LLI.SARx, LLI.DARx, LLI.LLPx and LLI.CTLx registers are fetched. The DMAC automatically reprograms the SARx, DARx, LLPx and CTLx channel registers from the LLPx(0).
13. Source and destination request single and burst DMA transactions to transfer the block of data (assuming non-memory peripheral). The DMAC acknowledges at the completion of every transaction (burst and single) in the block and carry out the block transfer.
 14. The CTLxH register is written out to system memory. For conditions under which the CTLxH register is written out to system memory, refer to 'Writeback' column of [Table 18-1 on page 175](#). The CTLxH register is written out to the same location on the same layer (LLPx.LMS) where it was originally fetched; that is, the location of the CTLx register of the linked list item fetched prior to the start of the block transfer. Only the second word of the CTLx register is written out, CTLxH, because only the CTLx.BLOCK_TS and CTLx.DONE fields have been updated by DMAC hardware. Additionally, the CTLx.DONE bit is asserted to indicate block completion. Therefore, software can poll

the LLI.CTLx.DONE bit of the CTLx register in the LLI to ascertain when a block transfer has completed.

Note: Do not poll the CTLx.DONE bit in the DMAC memory map. Instead, poll the LLI.CTLx.DONE bit in the LLI for that block. If the polled LLI.CTLx.DONE bit is asserted, then this block transfer has completed. This LLI.CTLx.DONE bit was cleared at the start of the transfer (Step 7).

- The DMAC does not wait for the block interrupt to be cleared, but continues fetching the next LLI from the memory location pointed to by current LLPx register and automatically reprograms the SARx, DARx, LLPx and CTLx channel registers. The DMA transfer continues until the DMAC determines that the CTLx and LLPx registers at the end of a block transfer match that described in Row 1 or Row 5 of [Table 18-1 on page 175](#). The DMAC then knows that the previous block transferred was the last block in the DMA transfer. The DMA transfer might look like that shown in [Figure 18-6 on page 180](#).

Figure 18-6. Multi-Block with Linked List Address for Source and Destination

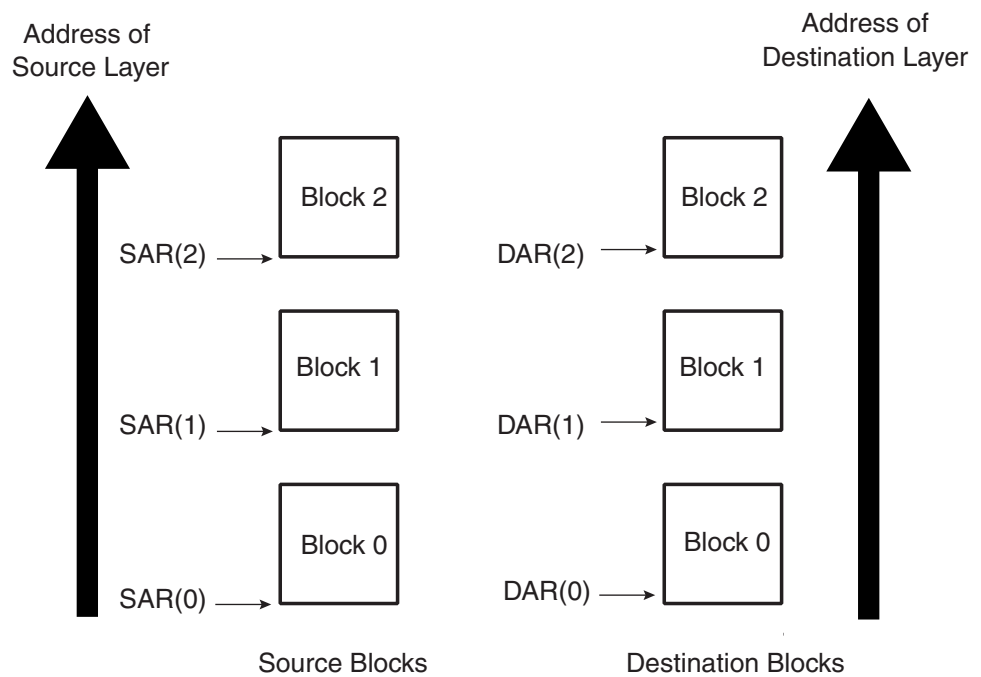

If the user needs to execute a DMA transfer where the source and destination address are contiguous but the amount of data to be transferred is greater than the maximum block size CTLx.BLOCK_TS, then this can be achieved using the type of multi-block transfer as shown in [Figure 18-7 on page 181](#).

Figure 18-7. Multi-Block with Linked Address for Source and Destination Blocks are Contiguous

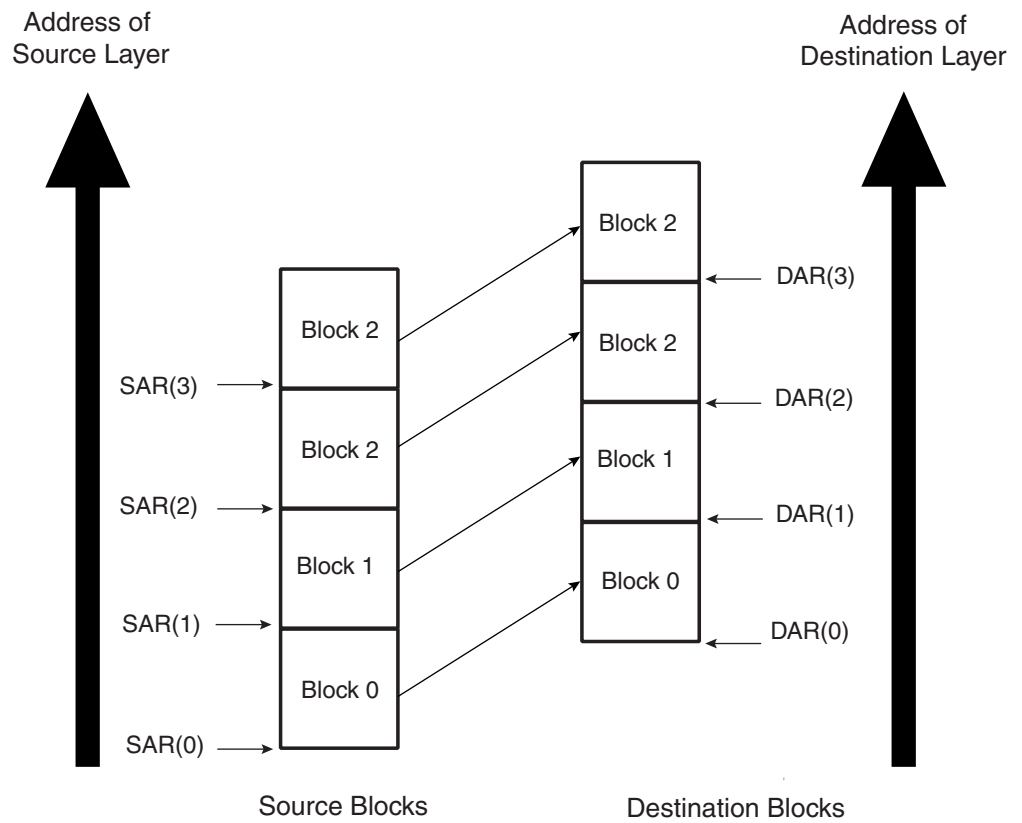

The DMA transfer flow is shown in [Figure 18-8 on page 182](#).

Figure 18-8. DMA Transfer Flow for Source and Destination Linked List Address

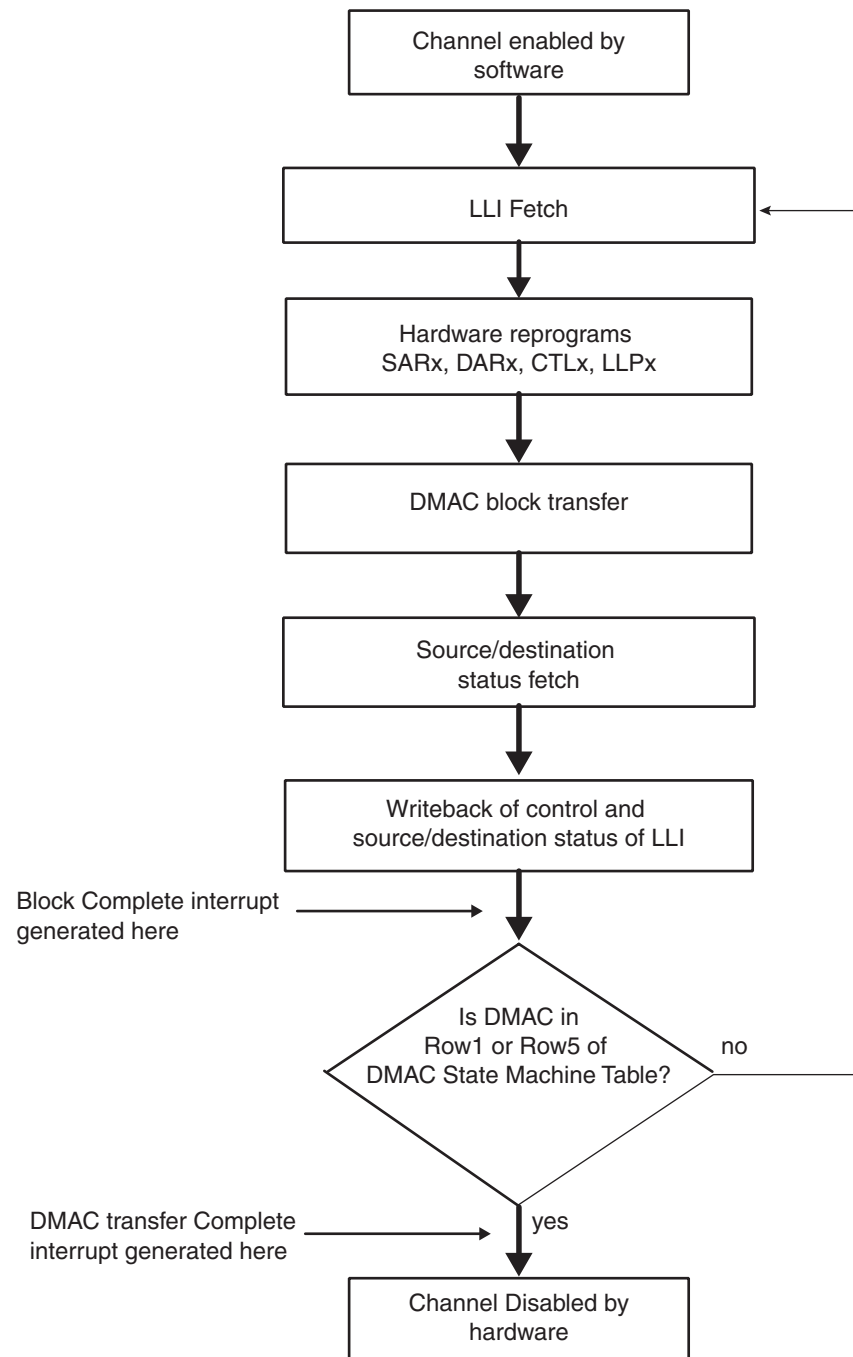

18.8.1.3 DMA Transfer Flow for Source and Destination Linked List Address *Multi-block Transfer with Source Address Auto-reloaded and Destination Address Auto-reloaded (Row 4)*

1. Read the Channel Enable register to choose an available (disabled) channel.
2. Clear any pending interrupts on the channel from the previous DMA transfer by writing to the Interrupt Clear registers: ClearTfr, ClearBlock, ClearSrcTran, ClearDstTran, ClearErr. Reading the Interrupt Raw Status and Interrupt Status registers confirms that all interrupts have been cleared.
3. Program the following channel registers:
 - a. Write the starting source address in the SARx register for channel x.
 - b. Write the starting destination address in the DARx register for channel x.
 - c. Program CTLx and CFGx according to Row 4 as shown in [Table 18-1 on page 175](#). Program the LLPx register with '0'.
 - d. Write the control information for the DMA transfer in the CTLx register for channel x. For example, in the register, you can program the following:
 - i. Set up the transfer type (memory or non-memory peripheral for source and destination) and flow control device by programming the TT_FC of the CTLx register.
 - ii. Set up the transfer characteristics, such as:
 - Transfer width for the source in the SRC_TR_WIDTH field.
 - Transfer width for the destination in the DST_TR_WIDTH field.
 - Source master layer in the SMS field where source resides.
 - Destination master layer in the DMS field where destination resides.
 - Incrementing/decrementing or fixed address for source in SINC field.
 - Incrementing/decrementing or fixed address for destination in DINC field.
 - e. Write the channel configuration information into the CFGx register for channel x. Ensure that the reload bits, CFGx.RELOAD_SR and CFGx.RELOAD_DS are enabled.
 - i. Designate the handshaking interface type (hardware or software) for the source and destination peripherals. This is not required for memory. This step requires programming the HS_SEL_SRC/HS_SEL_DST bits, respectively. Writing a '0' activates the hardware handshaking interface to handle source/destination requests for the specific channel. Writing a '1' activates the software handshaking interface to handle source/destination requests.
 - ii. If the hardware handshaking interface is activated for the source or destination peripheral, assign handshaking interface to the source and destination peripheral. This requires programming the SRC_PER and DEST_PER bits, respectively.
4. After the DMAC selected channel has been programmed, enable the channel by writing a '1' to the ChEnReg.CH_EN bit. Make sure that bit 0 of the DmaCfgReg register is enabled.
5. Source and destination request single and burst DMAC transactions to transfer the block of data (assuming non-memory peripherals). The DMAC acknowledges on completion of each burst/single transaction and carry out the block transfer.
6. When the block transfer has completed, the DMAC reloads the SARx, DARx and CTLx registers. Hardware sets the Block Complete interrupt. The DMAC then samples the row number as shown in [Table 18-1 on page 175](#). If the DMAC is in Row 1, then the DMA transfer has completed. Hardware sets the transfer complete interrupt and disables the channel. So you can either respond to the Block Complete or Transfer

Complete interrupts, or poll for the Channel Enable (ChEnReg.CH_EN) bit until it is disabled, to detect when the transfer is complete. If the DMAC is not in Row 1, the next step is performed.

7. The DMA transfer proceeds as follows:
 - a. If interrupts are enabled (CTLx.INT_EN = 1) and the block complete interrupt is unmasked (MaskBlock[x] = 1'b1, where x is the channel number) hardware sets the block complete interrupt when the block transfer has completed. It then stalls until the block complete interrupt is cleared by software. If the next block is to be the last block in the DMA transfer, then the block complete ISR (interrupt service routine) should clear the reload bits in the CFGx.RELOAD_SR and CFGx.RELOAD_DS registers. This put the DMAC into Row 1 as shown in [Table 18-1 on page 175](#). If the next block is not the last block in the DMA transfer, then the reload bits should remain enabled to keep the DMAC in Row 4.
 - b. If interrupts are disabled (CTLx.INT_EN = 0) or the block complete interrupt is masked (MaskBlock[x] = 1'b0, where x is the channel number), then hardware does not stall until it detects a write to the block complete interrupt clear register but starts the next block transfer immediately. In this case software must clear the reload bits in the CFGx.RELOAD_SR and CFGx.RELOAD_DS registers to put the DMAC into ROW 1 of [Table 18-1 on page 175](#) before the last block of the DMA transfer has completed. The transfer is similar to that shown in [Figure 18-9 on page 184](#). The DMA transfer flow is shown in [Figure 18-10 on page 185](#).

Figure 18-9. Multi-Block DMA Transfer with Source and Destination Address Auto-reloaded

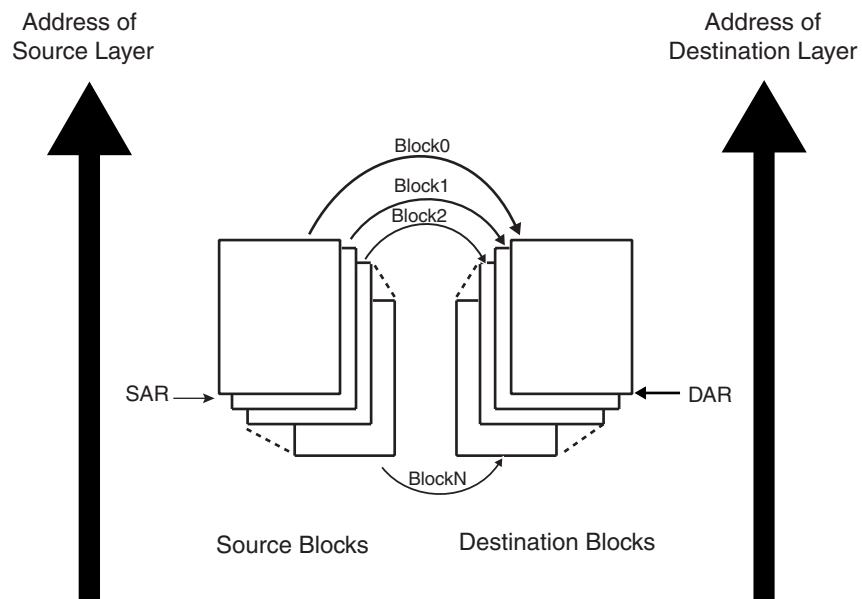
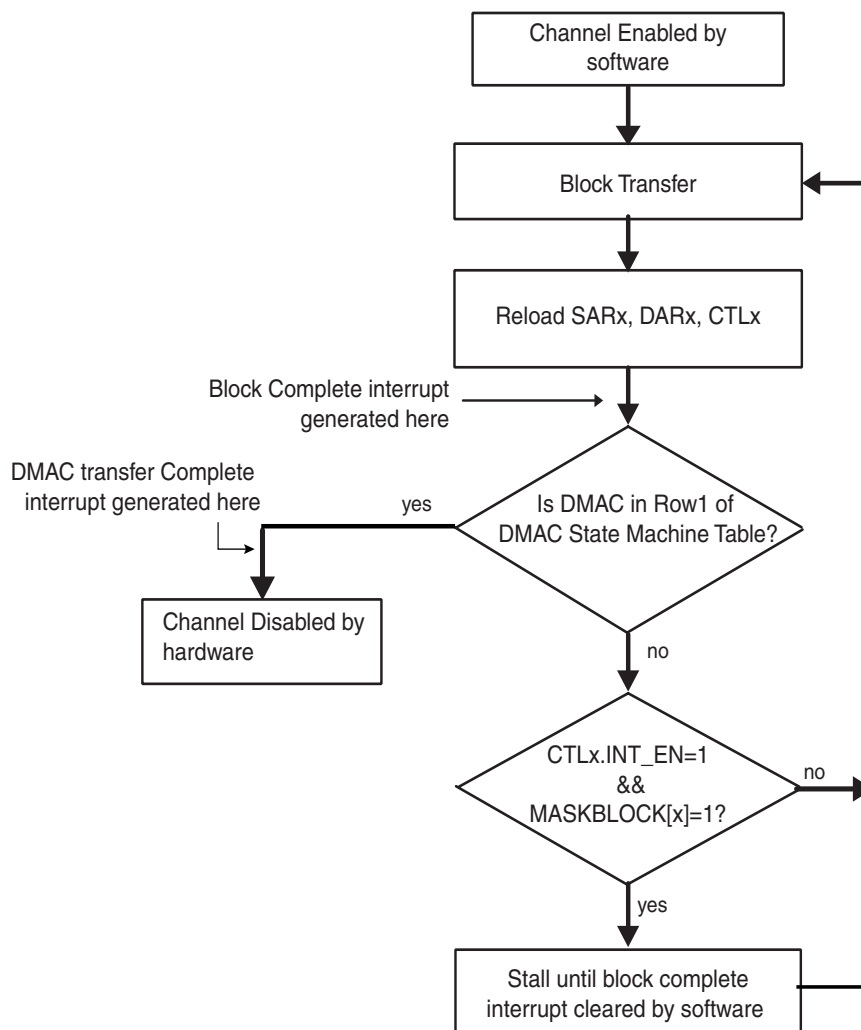

Figure 18-10. DMA Transfer Flow for Source and Destination Address Auto-reloaded



18.8.1.4 Multi-block Transfer with Source Address Auto-reloaded and Linked List Destination Address (Row7)

1. Read the Channel Enable register to choose a free (disabled) channel.
2. Set up the chain of linked list items (otherwise known as block descriptors) in memory. Write the control information in the LLI.CTLx register location of the block descriptor for each LLI in memory for channel x. For example, in the register you can program the following:
 - a. Set up the transfer type (memory or non-memory peripheral for source and destination) and flow control peripheral by programming the TT_FC of the CTLx register.
 - b. Set up the transfer characteristics, such as:
 - i. Transfer width for the source in the SRC_TR_WIDTH field.
 - ii. Transfer width for the destination in the DST_TR_WIDTH field.
 - iii. Source master layer in the SMS field where source resides.
 - iv. Destination master layer in the DMS field where destination resides.
 - v. Incrementing/decrementing or fixed address for source in SINC field.
 - vi. Incrementing/decrementing or fixed address for destination DINC field.

3. Write the starting source address in the SARx register for channel x.

Note: The values in the LLI.SARx register locations of each of the Linked List Items (LLIs) setup up in memory, although fetched during a LLI fetch, are not used.

4. Write the channel configuration information into the CFGx register for channel x.
 - a. Designate the handshaking interface type (hardware or software) for the source and destination peripherals. This is not required for memory. This step requires programming the HS_SEL_SRC/HS_SEL_DST bits, respectively. Writing a '0' activates the hardware handshaking interface to handle source/destination requests for the specific channel. Writing a '1' activates the software handshaking interface source/destination requests.
 - b. If the hardware handshaking interface is activated for the source or destination peripheral, assign handshaking interface to the source and destination peripheral. This requires programming the SRC_PER and DEST_PER bits, respectively.
5. Make sure that the LLI.CTLx register locations of all LLIs in memory (except the last) are set as shown in Row 7 of [Table 18-1 on page 175](#) while the LLI.CTLx register of the last Linked List item must be set as described in Row 1 or Row 5 of [Table 18-1](#). [Figure 18-5 on page 174](#) shows a Linked List example with two list items.
6. Make sure that the LLI.LLPx register locations of all LLIs in memory (except the last) are non-zero and point to the next Linked List Item.
7. Make sure that the LLI.DARx register location of all LLIs in memory point to the start destination block address proceeding that LLI fetch.
8. Make sure that the LLI.CTLx.DONE field of the LLI.CTLx register locations of all LLIs in memory is cleared.
9. Clear any pending interrupts on the channel from the previous DMA transfer by writing to the Interrupt Clear registers: ClearTfr, ClearBlock, ClearSrcTran, ClearDstTran, ClearErr. Reading the Interrupt Raw Status and Interrupt Status registers confirms that all interrupts have been cleared.
10. Program the CTLx, CFGx registers according to Row 7 as shown in [Table 18-1 on page 175](#).
11. Program the LLPx register with LLPx(0), the pointer to the first Linked List item.
12. Finally, enable the channel by writing a '1' to the ChEnReg.CH_EN bit. The transfer is performed. Make sure that bit 0 of the DmaCfgReg register is enabled.
13. The DMAC fetches the first LLI from the location pointed to by LLPx(0).

Note: The LLI.SARx, LLI.DARx, LLI.LLPx and LLI.CTLx registers are fetched. The LLI.SARx register although fetched is not used.

14. Source and destination request single and burst DMAC transactions to transfer the block of data (assuming non-memory peripherals). DMAC acknowledges at the completion of every transaction (burst and single) in the block and carry out the block transfer.
15. The CTLxH register is written out to system memory. For conditions under which the CTLxH register is written out to system memory, refer to 'Writeback' column of [Table 18-1 on page 175](#). The CTLxH register is written out to the same location on the same layer (LLPx.LMS) where it was originally fetched, that is the location of the CTLx register of the linked list item fetched prior to the start of the block transfer. Only the second word of the CTLx register is written out, CTLxH, because only the CTLx.BLOCK_TS and CTLx.DONE fields have been updated by hardware within the DMAC. The LLI.CTLx.DONE bit is asserted to indicate block completion. Therefore, software can

poll the LLI.CTLx.DONE bit field of the CTLx register in the LLI to ascertain when a block transfer has completed.

Note: Do not poll the CTLx.DONE bit in the DMAC memory map. Instead poll the LLI.CTLx.DONE bit in the LLI for that block. If the polled LLI.CTLx.DONE bit is asserted, then this block transfer has completed. This LLI.CTLx.DONE bit was cleared at the start of the transfer (Step 8).

16. The DMAC reloads the SARx register from the initial value. Hardware sets the block complete interrupt. The DMAC samples the row number as shown in [Table 18-1 on page 175](#). If the DMAC is in Row 1 or 5, then the DMA transfer has completed. Hardware sets the transfer complete interrupt and disables the channel. You can either respond to the Block Complete or Transfer Complete interrupts, or poll for the Channel Enable (ChEnReg.CH_EN) bit until it is cleared by hardware, to detect when the transfer is complete. If the DMAC is not in Row 1 or 5 as shown in [Table 18-1 on page 175](#) the following steps are performed.
17. The DMA transfer proceeds as follows:
 - a. If interrupts are enabled (CTLx.INT_EN = 1) and the block complete interrupt is unmasked (MaskBlock[x] = 1'b1, where x is the channel number) hardware sets the block complete interrupt when the block transfer has completed. It then stalls until the block complete interrupt is cleared by software. If the next block is to be the last block in the DMA transfer, then the block complete ISR (interrupt service routine) should clear the CFGx.RELOAD_SR source reload bit. This puts the DMAC into Row1 as shown in [Table 18-1 on page 175](#). If the next block is not the last block in the DMA transfer, then the source reload bit should remain enabled to keep the DMAC in Row 7 as shown in [Table 18-1 on page 175](#).
 - b. If interrupts are disabled (CTLx.INT_EN = 0) or the block complete interrupt is masked (MaskBlock[x] = 1'b0, where x is the channel number) then hardware does not stall until it detects a write to the block complete interrupt clear register but starts the next block transfer immediately. In this case, software must clear the source reload bit, CFGx.RELOAD_SR, to put the device into Row 1 of [Table 18-1 on page 175](#) before the last block of the DMA transfer has completed.
18. The DMAC fetches the next LLI from memory location pointed to by the current LLPx register, and automatically reprograms the DARx, CTLx and LLPx channel registers. Note that the SARx is not re-programmed as the reloaded value is used for the next DMA block transfer. If the next block is the last block of the DMA transfer then the CTLx and LLPx registers just fetched from the LLI should match Row 1 or Row 5 of [Table 18-1 on page 175](#). The DMA transfer might look like that shown in [Figure 18-11 on page 188](#).

Figure 18-11. Multi-Block DMA Transfer with Source Address Auto-reloaded and Linked List

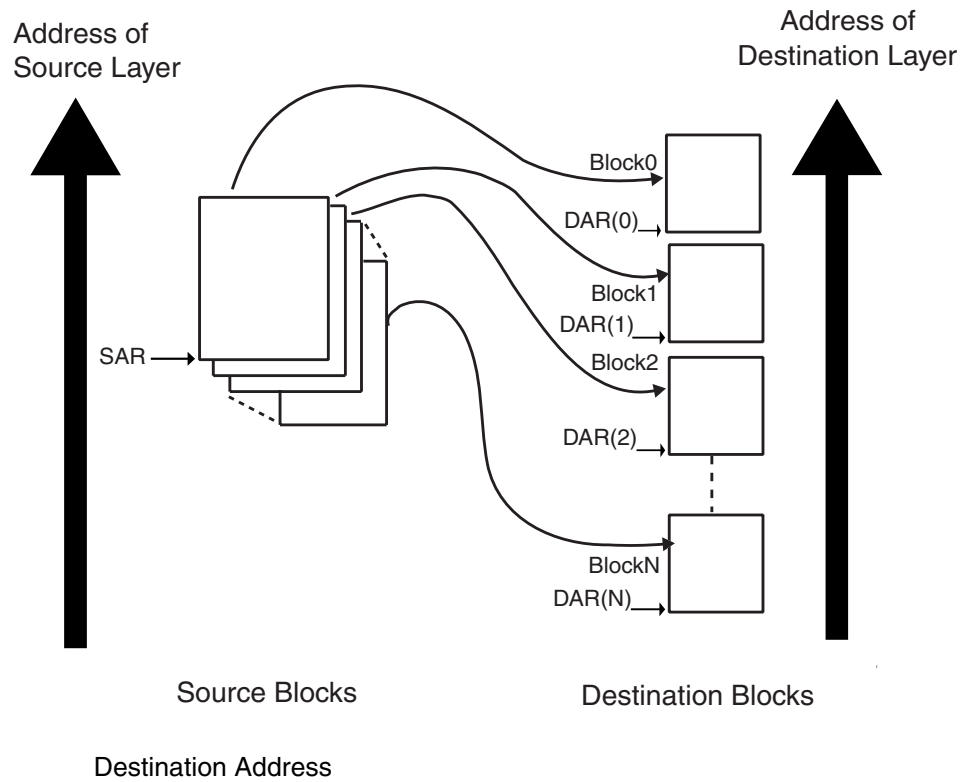

The DMA Transfer flow is shown in [Figure 18-12 on page 189](#)

Figure 18-12. DMA Transfer Flow for Source Address Auto-reloaded and Linked List Destination Address

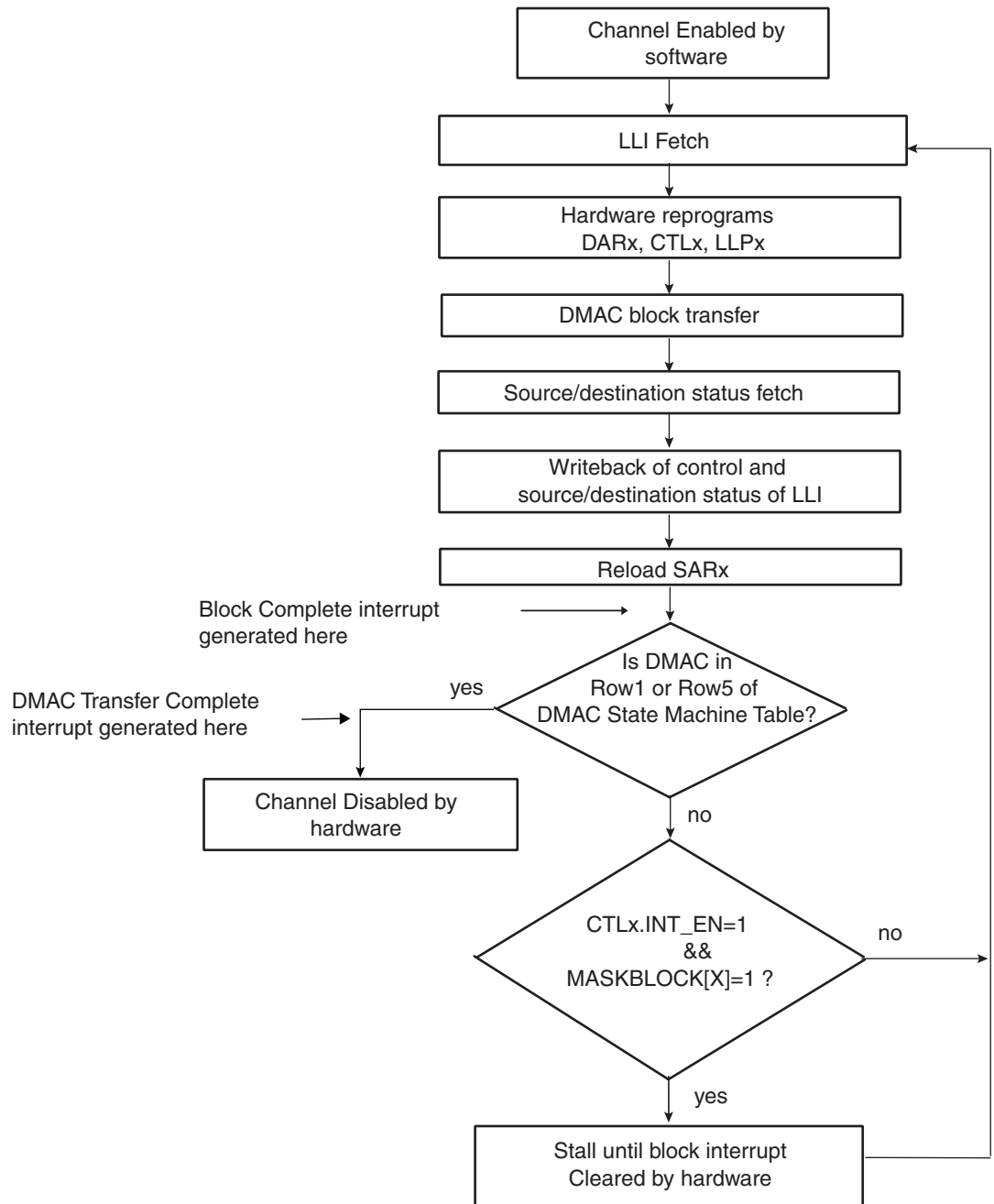

18.8.1.5 Multi-block Transfer with Source Address Auto-reloaded and Contiguous Destination Address (Row 3)

1. Read the Channel Enable register to choose a free (disabled) channel.
2. Clear any pending interrupts on the channel from the previous DMA transfer by writing to the Interrupt Clear registers: ClearTfr, ClearBlock, ClearSrcTran, ClearDstTran, ClearErr. Reading the Interrupt Raw Status and Interrupt Status registers confirms that all interrupts have been cleared.
3. Program the following channel registers:
 - a. Write the starting source address in the SARx register for channel x.
 - b. Write the starting destination address in the DARx register for channel x.
 - c. Program CTLx and CFGx according to Row 3 as shown in [Table 18-1 on page 175](#). Program the LLPx register with '0'.
 - d. Write the control information for the DMA transfer in the CTLx register for channel x. For example, in this register, you can program the following:
 - i. Set up the transfer type (memory or non-memory peripheral for source and destination) and flow control device by programming the TT_FC of the CTLx register.
 - ii. Set up the transfer characteristics, such as:
 - Transfer width for the source in the SRC_TR_WIDTH field.
 - Transfer width for the destination in the DST_TR_WIDTH field.
 - Source master layer in the SMS field where source resides.
 - Destination master layer in the DMS field where destination resides.
 - Incrementing/decrementing or fixed address for source in SINC field.
 - Incrementing/decrementing or fixed address for destination in DINC field.
 - e. Write the channel configuration information into the CFGx register for channel x.
 - i. Designate the handshaking interface type (hardware or software) for the source and destination peripherals. This is not required for memory. This step requires programming the HS_SEL_SRC/HS_SEL_DST bits, respectively. Writing a '0' activates the hardware handshaking interface to handle source/destination requests for the specific channel. Writing a '1' activates the software handshaking interface to handle source/destination requests.
 - ii. If the hardware handshaking interface is activated for the source or destination peripheral, assign handshaking interface to the source and destination peripheral. This requires programming the SRC_PER and DEST_PER bits, respectively.
4. After the DMAC channel has been programmed, enable the channel by writing a '1' to the ChEnReg.CH_EN bit. Make sure that bit 0 of the DmaCfgReg register is enabled.
5. Source and destination request single and burst DMAC transactions to transfer the block of data (assuming non-memory peripherals). The DMAC acknowledges at the completion of every transaction (burst and single) in the block and carries out the block transfer.
6. When the block transfer has completed, the DMAC reloads the SARx register. The DARx register remains unchanged. Hardware sets the block complete interrupt. The DMAC then samples the row number as shown in [Table 18-1 on page 175](#). If the DMAC is in Row 1, then the DMA transfer has completed. Hardware sets the transfer complete interrupt and disables the channel. So you can either respond to the Block Complete or Transfer Complete interrupts, or poll for the Channel Enable (ChEnReg.CH_EN) bit until it is cleared by hardware, to detect when the transfer is complete. If the DMAC is not in Row 1, the next step is performed.

7. The DMA transfer proceeds as follows:
 - a. If interrupts are enabled ($CTLx.INT_EN = 1$) and the block complete interrupt is unmasked ($MaskBlock[x] = 1'b1$, where x is the channel number) hardware sets the block complete interrupt when the block transfer has completed. It then stalls until the block complete interrupt is cleared by software. If the next block is to be the last block in the DMA transfer, then the block complete ISR (interrupt service routine) should clear the source reload bit, $CFGx.RELOAD_SR$. This puts the DMAC into Row1 as shown in [Table 18-1 on page 175](#). If the next block is not the last block in the DMA transfer then the source reload bit should remain enabled to keep the DMAC in Row3 as shown in [Table 18-1 on page 175](#).
 - b. If interrupts are disabled ($CTLx.INT_EN = 0$) or the block complete interrupt is masked ($MaskBlock[x] = 1'b0$, where x is the channel number) then hardware does not stall until it detects a write to the block complete interrupt clear register but starts the next block transfer immediately. In this case software must clear the source reload bit, $CFGx.RELOAD_SR$, to put the device into ROW 1 of [Table 18-1 on page 175](#) before the last block of the DMA transfer has completed.

The transfer is similar to that shown in [Figure 18-13 on page 191](#).

The DMA Transfer flow is shown in [Figure 18-14 on page 192](#).

Figure 18-13. Multi-block Transfer with Source Address Auto-reloaded and Contiguous Destination Address

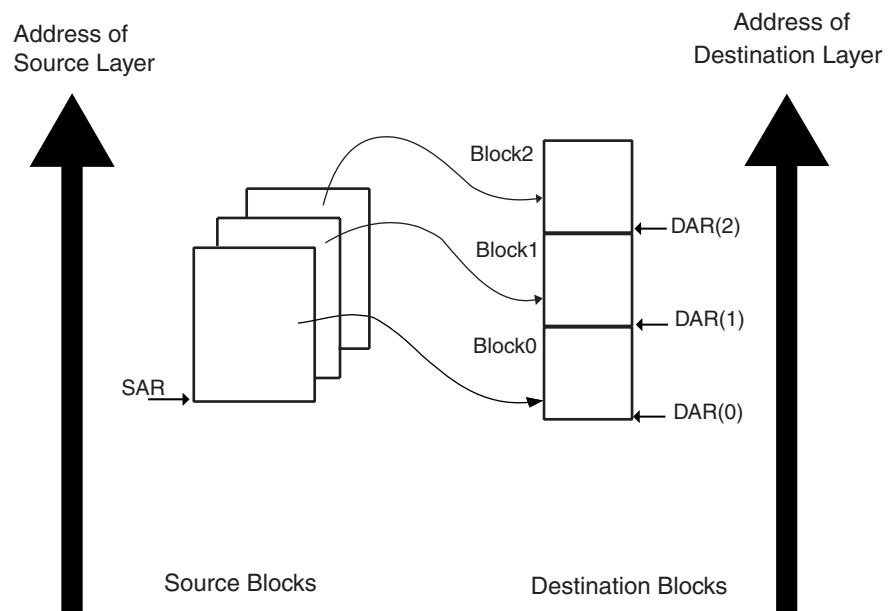
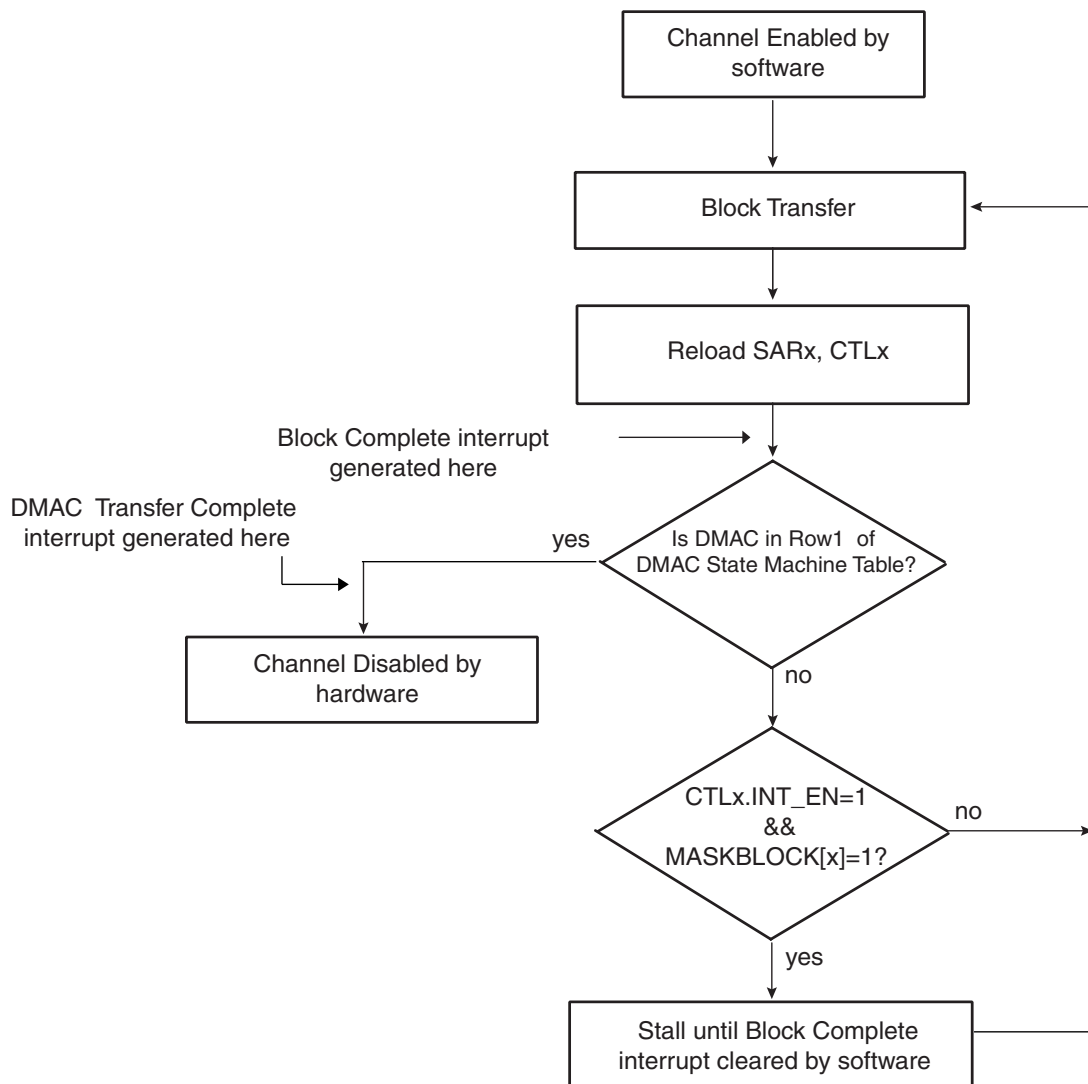

Figure 18-14. DMA Transfer for Source Address Auto-reloaded and Contiguous Destination Address



18.8.1.6 Multi-block DMA Transfer with Linked List for Source and Contiguous Destination Address (Row 8)

1. Read the Channel Enable register to choose a free (disabled) channel.
2. Set up the linked list in memory. Write the control information in the LLI. CTLx register location of the block descriptor for each LLI in memory for channel x. For example, in the register, you can program the following:
 - a. Set up the transfer type (memory or non-memory peripheral for source and destination) and flow control device by programming the TT_FC of the CTLx register.
 - b. Set up the transfer characteristics, such as:
 - i. Transfer width for the source in the SRC_TR_WIDTH field.
 - ii. Transfer width for the destination in the DST_TR_WIDTH field.
 - iii. Source master layer in the SMS field where source resides.
 - iv. Destination master layer in the DMS field where destination resides.

- v. Incrementing/decrementing or fixed address for source in SINC field.
 - vi. Incrementing/decrementing or fixed address for destination DINC field.
3. Write the starting destination address in the DARx register for channel x.
- Note: The values in the LLI.DARx register location of each Linked List Item (LLI) in memory, although fetched during an LLI fetch, are not used.
4. Write the channel configuration information into the CFGx register for channel x.
 - a. Designate the handshaking interface type (hardware or software) for the source and destination peripherals. This is not required for memory. This step requires programming the HS_SEL_SRC/HS_SEL_DST bits, respectively. Writing a '0' activates the hardware handshaking interface to handle source/destination requests for the specific channel. Writing a '1' activates the software handshaking interface to handle source/destination requests.
 - b. If the hardware handshaking interface is activated for the source or destination peripheral, assign handshaking interface to the source and destination peripherals. This requires programming the SRC_PER and DEST_PER bits, respectively.
 5. Make sure that all LLI.CTLx register locations of the LLI (except the last) are set as shown in Row 8 of [Table 18-1 on page 175](#), while the LLI.CTLx register of the last Linked List item must be set as described in Row 1 or Row 5 of [Table 18-1](#). [Figure 18-5 on page 174](#) shows a Linked List example with two list items.
 6. Make sure that the LLI.LLPx register locations of all LLIs in memory (except the last) are non-zero and point to the next Linked List Item.
 7. Make sure that the LLI.SARx register location of all LLIs in memory point to the start source block address proceeding that LLI fetch.
 8. Make sure that the LLI.CTLx.DONE field of the LLI.CTLx register locations of all LLIs in memory is cleared.
 9. Clear any pending interrupts on the channel from the previous DMA transfer by writing to the Interrupt Clear registers: ClearTfr, ClearBlock, ClearSrcTran, ClearDstTran, ClearErr. Reading the Interrupt Raw Status and Interrupt Status registers confirms that all interrupts have been cleared.
 10. Program the CTLx, CFGx registers according to Row 8 as shown in [Table 18-1 on page 175](#)
 11. Program the LLPx register with LLPx(0), the pointer to the first Linked List item.
 12. Finally, enable the channel by writing a '1' to the ChEnReg.CH_EN bit. The transfer is performed. Make sure that bit 0 of the DmaCfgReg register is enabled.
 13. The DMAC fetches the first LLI from the location pointed to by LLPx(0).
- Note: The LLI.SARx, LLI.DARx, LLI.LLPx and LLI.CTLx registers are fetched. The LLI.DARx register location of the LLI although fetched is not used. The DARx register in the DMAC remains unchanged.
14. Source and destination requests single and burst DMAC transactions to transfer the block of data (assuming non-memory peripherals). The DMAC acknowledges at the completion of every transaction (burst and single) in the block and carry out the block transfer.
 15. The CTLxH register is written out to system memory. For conditions under which the CTLxH register is written out to system memory, refer to 'Writeback' column of [Table 18-1 on page 175](#). The CTLxH register is written out to the same location on the same layer (LLPx.LMS) where it was originally fetched, that is the location of the CTLx register of the linked list item fetched prior to the start of the block transfer. Only the second word of the CTLx register is written out, CTLxH, because only the CTLx.BLOCK_TS and CTLx.DONE fields have been updated by hardware within the DMAC. Additionally,

the CTLx.DONE bit is asserted to indicate block completion. Therefore, software can poll the LLI.CTLx.DONE bit field of the CTLx register in the LLI to ascertain when a block transfer has completed.

Note: Do not poll the CTLx.DONE bit in the DMAC memory map. Instead poll the LLI.CTLx.DONE bit in the LLI for that block. If the polled LLI.CTLx.DONE bit is asserted, then this block transfer has completed. This LLI.CTLx.DONE bit was cleared at the start of the transfer (Step 8).

16. The DMAC does not wait for the block interrupt to be cleared, but continues and fetches the next LLI from the memory location pointed to by current LLPx register and automatically reprograms the SARx, CTLx and LLPx channel registers. The DARx register is left unchanged. The DMA transfer continues until the DMAC samples the CTLx and LLPx registers at the end of a block transfer match that described in Row 1 or Row 5 of [Table 18-1 on page 175](#). The DMAC then knows that the previous block transferred was the last block in the DMA transfer.

The DMAC transfer might look like that shown in [Figure 18-15 on page 194](#) Note that the destination address is decrementing.

Figure 18-15. DMA Transfer with Linked List Source Address and Contiguous Destination Address

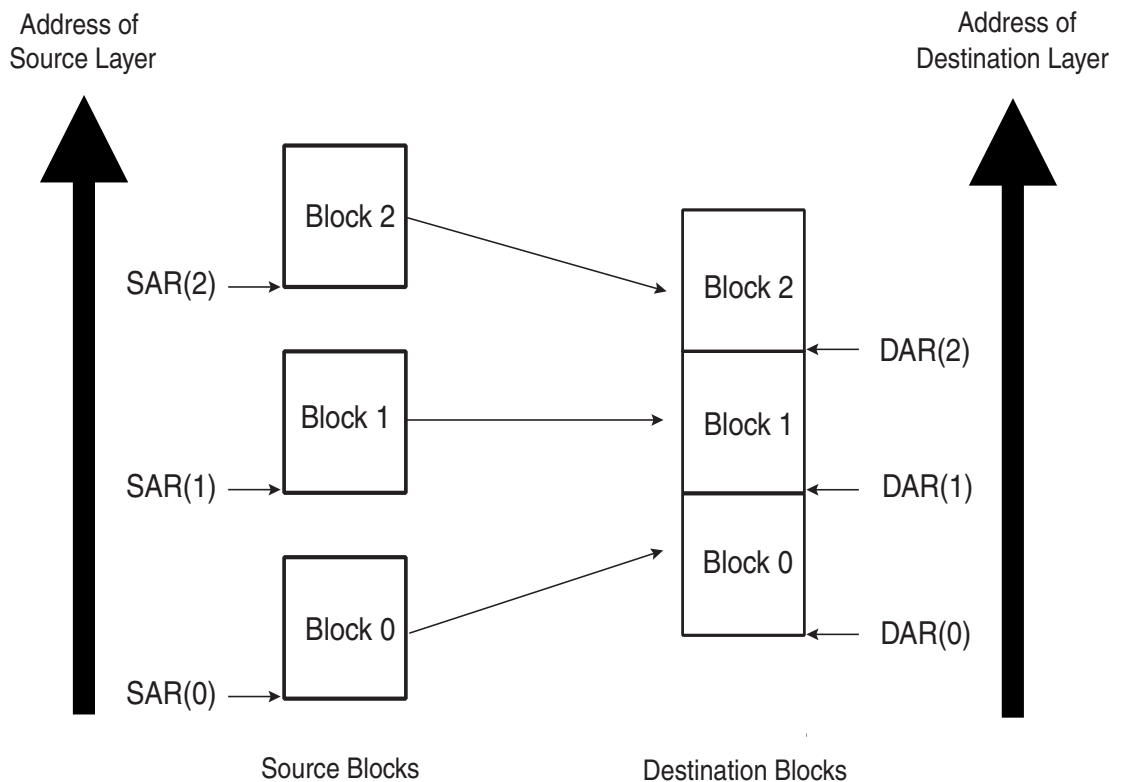

The DMA transfer flow is shown in [Figure 18-16 on page 195](#).

Figure 18-16. DMA Transfer Flow for Source Address Auto-reloaded and Contiguous Destination Address

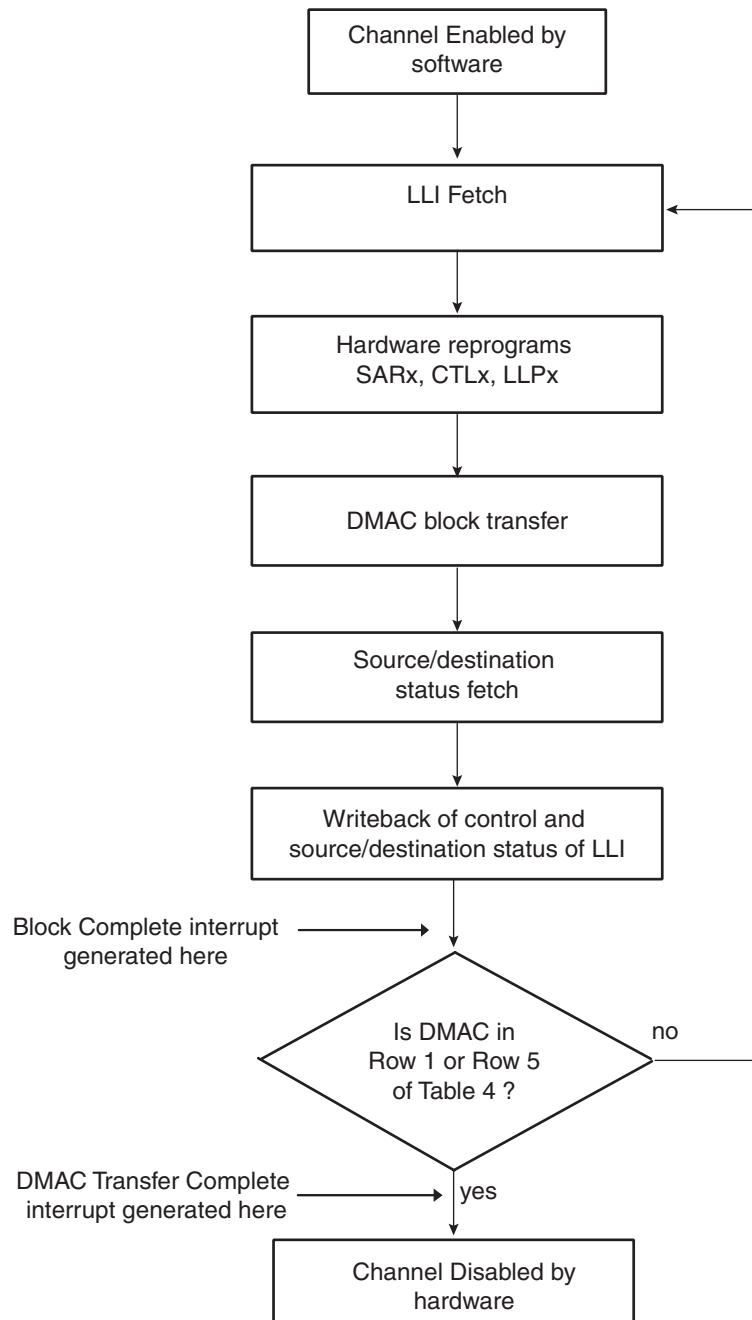

18.9 Disabling a Channel Prior to Transfer Completion

Under normal operation, software enables a channel by writing a '1' to the Channel Enable Register, ChEnReg.CH_EN, and hardware disables a channel on transfer completion by clearing the ChEnReg.CH_EN register bit.

The recommended way for software to disable a channel without losing data is to use the CH_SUSP bit in conjunction with the FIFO_EMPTY bit in the Channel Configuration Register (CFGx) register.

1. If software wishes to disable a channel prior to the DMA transfer completion, then it can set the CFGx.CH_SUSP bit to tell the DMAC to halt all transfers from the source peripheral. Therefore, the channel FIFO receives no new data.
2. Software can now poll the CFGx.FIFO_EMPTY bit until it indicates that the channel FIFO is empty.
3. The ChEnReg.CH_EN bit can then be cleared by software once the channel FIFO is empty.

When CTLx.SRC_TR_WIDTH is less than CTLx.DST_TR_WIDTH and the CFGx.CH_SUSP bit is high, the CFGx.FIFO_EMPTY is asserted once the contents of the FIFO do not permit a single word of CTLx.DST_TR_WIDTH to be formed. However, there may still be data in the channel FIFO but not enough to form a single transfer of CTLx.DST_TR_WIDTH width. In this configuration, once the channel is disabled, the remaining data in the channel FIFO are not transferred to the destination peripheral. It is permitted to remove the channel from the suspension state by writing a '0' to the CFGx.CH_SUSP register. The DMA transfer completes in the normal manner.

Note: If a channel is disabled by software, an active single or burst transaction is not guaranteed to receive an acknowledgement.

18.9.1 Abnormal Transfer Termination

A DMAC DMA transfer may be terminated abruptly by software by clearing the channel enable bit, ChEnReg.CH_EN. This does not mean that the channel is disabled immediately after the ChEnReg.CH_EN bit is cleared over the HSB slave interface. Consider this as a request to disable the channel. The ChEnReg.CH_EN must be polled and then it must be confirmed that the channel is disabled by reading back 0. A case where the channel is not be disabled after a channel disable request is where either the source or destination has received a split or retry response. The DMAC must keep re-attempting the transfer to the system HADDR that originally received the split or retry response until an OKAY response is returned. To do otherwise is an System Bus protocol violation.

Software may terminate all channels abruptly by clearing the global enable bit in the DMAC Configuration Register (DmaCfgReg[0]). Again, this does not mean that all channels are disabled immediately after the DmaCfgReg[0] is cleared over the HSB slave interface. Consider this as a request to disable all channels. The ChEnReg must be polled and then it must be confirmed that all channels are disabled by reading back '0'.

Note: If the channel enable bit is cleared while there is data in the channel FIFO, this data is not sent to the destination peripheral and is not present when the channel is re-enabled. For read sensitive source peripherals such as a source FIFO this data is therefore lost. When the source is not a read sensitive device (i.e., memory), disabling a channel without waiting for the channel FIFO to empty may be acceptable as the data is available from the source peripheral upon request and is not lost.

Note: If a channel is disabled by software, an active single or burst transaction is not guaranteed to receive an acknowledgement.



18.10 DMA Controller (DMAC) User Interface

Table 18-2. DMA Controller (DMAC) User Interface

Offset	Register	Register Name	Access	Reset Value
0x0	Channel 0 Source Address Register	SAR0	Read/Write	0x0
0x4	Reserved	-	-	-
0x8	Channel 0 Destination Address Register	DAR0	Read/Write	0x0
0xC	Reserved	-	-	-
0x10	Channel 0 Linked List Pointer Register	LLP0	Read/Write	0x0
0x14	Reserved	-	-	-
0x18	Channel 0 Control Register Low	CTL0L	Read/Write	-
0x1C	Channel 0 Control Register High	CTL0H	Read/Write	-
0x20	Reserved	-	-	-
0x24	Reserved	-	-	-
0x28	Reserved	-	-	-
0x2C	Reserved	-	-	-
0x30	Reserved	-	-	-
0x34	Reserved	-	-	-
0x38	Reserved	-	-	-
0x3C	Reserved	-	-	-
0x40	Channel 0 Configuration Register low	CFG0L	Read/Write	0x00000c00
0x44	Channel 0 Configuration Register High	CFG0H	Read/Write	0x00000004
0x48	Reserved	-	-	-
0x4C	Reserved	-	-	-
0x50	Reserved	-	-	-
0x54	Reserved	-	-	-
0x58	Channel 1 Source Address Register	SAR1	Read/Write	0x0
0x5C	Reserved	-	-	-
0x60	Channel 1 Destination Address Register	DAR1	Read/Write	0x0
0x64	Reserved	-	-	-
0x68	Channel 1 Linked List Pointer Register	LLP1	Read/Write	0x0
0x7C	Reserved	-	-	-
0x70	Channel 1 Control Register Low	CTL1L	Read/Write	-
0x74	Channel 1 Control Register High	CTL1H	Read/Write	-
0x78	Reserved	-	-	-
0x7C	Reserved	-	-	-
0x80	Reserved	-	-	-
0x84	Reserved	-	-	-
0x88	Reserved	-	-	-

Table 18-2. DMA Controller (DMAC) User Interface (Continued)

Offset	Register	Register Name	Access	Reset Value
0x8C	Reserved	-	-	-
0x90	Reserved	-	-	-
0x94	Reserved	-	-	-
0x98	Channel 1 Configuration Register Low	CFG1L	Read/Write	0x00000c20
0x9C	Channel 1 Configuration Register High	CFG1H	Read/Write	0x00000004
0xa0	Reserved	-	-	-
0xa4	Reserved	-	-	-
0xa8	Reserved	-	-	-
0xac	Channel 2 Source Address Register	SAR2	Read/Write	0x0
0xb0	Reserved	-	-	-
0xb4	Channel 2 Destination Address Register	DAR2	Read/Write	0x0
0xb8	Reserved	-	-	-
0xbc	Channel 2 Linked List Pointer Register	LLP2	Read/Write	0x0
0xc0	Reserved	-	-	-
0xc4	Channel 2 Control Register Low	CTL2L	Read/Write	-
0xc8	Channel 2 Control Register High	CTL2H	Read/Write	-
0xcc	Reserved	-	-	-
0xd0	Reserved	-	-	-
0xd4	Reserved	-	-	-
0xd8	Reserved	-	-	-
0xdc	Reserved	-	-	-
0xe0	Reserved	-	-	-
0xe4	Reserved	-	-	-
0xe8	Reserved	-	-	-
0xec	Channel 2 Configuration Register low	CFG2L	Read/Write	0x00000c00
0xf0	Channel 2 Configuration Register High	CFG2H	Read/Write	0x00000004
0xf4	Reserved	-	-	-
0xf8	Reserved	-	-	-
0xfc	Reserved	-	-	-
0x100..0x2b c	Reserved	-	-	-
0x2c0	Raw Status for IntTfr Interrupt	RawTfr	Read	0x0
0x2c4	Reserved	-	-	-
0x2c8	Raw Status for IntBlock Interrupt	RawBlock	Read	0x0
0x2cc	Reserved	-	-	-
0x2d0	Raw Status for IntSrcTran Interrupt	RawSrcTran	Read	0x0

Table 18-2. DMA Controller (DMAC) User Interface (Continued)

Offset	Register	Register Name	Access	Reset Value
0x2d4	Reserved	-	-	-
0x2d8	Raw Status for IntDstTran Interrupt	RawDstTran	Read	0x0
0x2dc	Reserved	-	-	-
0x2e0	Raw Status for IntErr Interrupt	RawErr	Read	0x0
0x2e4	Reserved	-	-	-
0x2e8	Status for IntTfr Interrupt	StatusTfr	Read	0x0
0x2ec	Reserved	-	-	-
0x2f0	Status for IntBlock Interrupt	StatusBlock	Read	0x0
0x2f4	Reserved	-	-	-
0x2f8	Status for IntSrcTran Interrupt	StatusSrcTran	Read	0x0
0x2fc	Reserved	-	-	-
0x300	Status for IntDstTran Interrupt	StatusDstTran	Read	0x0
0x304	Reserved	-	-	-
0x308	Status for IntErr Interrupt	StatusErr	Read	0x0
0x30c	Reserved	-	-	-
0x310	Mask for IntTfr Interrupt	MaskTfr	Read/Write	0x0
0x314	Reserved	-	-	-
0x318	Mask for IntBlock Interrupt	MaskBlock	Read/Write	0x0
0x31c	Reserved	-	-	-
0x320	Mask for IntSrcTran Interrupt	MaskSrcTran	Read/Write	0x0
0x324	Reserved	-	-	-
0x328	Mask for IntDstTran Interrupt	MaskDstTran	Read/Write	0x0
0x32c	Reserved	-	-	-
0x330	Mask for IntErr Interrupt	MaskErr	Read/Write	0x0
0x334	Reserved	-	-	-
0x338	Clear for IntTfr Interrupt	ClearTfr	Write	0x0
0x33c	Reserved	-	-	-
0x340	Clear for IntBlock Interrupt	ClearBlock	Write	0x0
0x344	Reserved	-	-	-
0x348	Clear for IntSrcTran Interrupt	ClearSrcTran	Write	0x0
0x34c	Reserved	-	-	-
0x350	Clear for IntDstTran Interrupt	ClearDstTran	Write	0x0
0x354	Reserved	-	-	-
0x358	Clear for IntErr Interrupt	ClearErr	Write	0x0
0x35c	Reserved	-	-	-
0x360	Status for each interrupt type	StatusInt	Read	0x0

Table 18-2. DMA Controller (DMAC) User Interface (Continued)

Offset	Register	Register Name	Access	Reset Value
0x364	Reserved	-	-	-
0x368	Source Software Transaction Request Register	ReqSrcReg	Read/Write	0x0
0x36c	Reserved	-	-	-
0x370	Destination Software Transaction Request Register	ReqDstReg	Read/Write	0x0
0x374	Reserved	-	-	-
0x378	Single Source Transaction Request Register	SglReqSrcReg	Read/Write	0x0
0x37c	Reserved	-	-	-
0x380	Single Destination Transaction Request Register	SglReqDstReg	Read/Write	0x0
0x384	Reserved	-	-	-
0x388	Last Source Transaction Request Register	LstSrcReg	Read/Write	0x0
0x38c	Reserved	-	-	-
0x390	Last Destination Transaction Request Register	LstDstReg	Read/Write	0x0
0x394	Reserved	-	-	-
0x398	DMA Configuration Register	DmaCfgReg	Read/Write	0x0
0x39c	Reserved	-	-	-
0x3a0	Channel Enable Register	ChEnReg	Read/Write	0x0
0x3a4	Reserved	-	-	-
0x3a8	DMA ID Register	IdReg	Read	DMA_ID_NUM
0x3ac	Reserved	-	-	-
0x3b0	DMA Test Register	DmaTestReg	Read/Write	-
0x3b4	Reserved	-	-	-
0x3b8	Reserved	-	-	-
0x3b8	Reserved	-	-	-

18.10.1 Channel x Source Address Register

Name: SARx

Access: Read/Write

Reset: 0x0

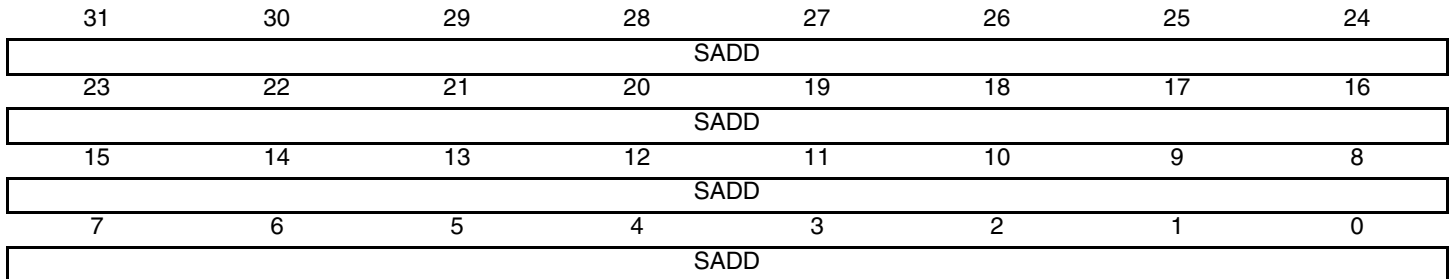

The address offset for each channel is: [x *0x58]

For example, SAR0: 0x000, SAR1: 0x058, etc.

- **SADD: Source Address of DMA transfer**

The starting System Bus source address is programmed by software before the DMA channel is enabled or by a LLI update before the start of the DMA transfer. As the DMA transfer is in progress, this register is updated to reflect the source address of the current System Bus transfer.

Updated after each source System Bus transfer. The SINC field in the CTLx register determines whether the address increments, decrements, or is left unchanged on every source System Bus transfer throughout the block transfer.

18.10.2 Channel x Destination Address Register

Name: DARx

Access: Read/Write

Reset: 0x0

31	30	29	28	27	26	25	24
DADD							
23	22	21	20	19	18	17	16
DADD							
15	14	13	12	11	10	9	8
DADD							
7	6	5	4	3	2	1	0
DADD							

The address offset for each channel is: 0x08+[x * 0x58]

For example, DAR0: 0x008, DAR1: 0x060, etc.

• **DADD: Destination Address of DMA transfer**

The starting System Bus destination address is programmed by software before the DMA channel is enabled or by a LLI update before the start of the DMA transfer. As the DMA transfer is in progress, this register is updated to reflect the destination address of the current System Bus transfer.

Updated after each destination System Bus transfer. The DINC field in the CTLx register determines whether the address increments, decrements or is left unchanged on every destination System Bus transfer throughout the block transfer.

18.10.3 Linked List Pointer Register for Channel x

Name: LLPx

Access: Read/Write

Reset: 0x0

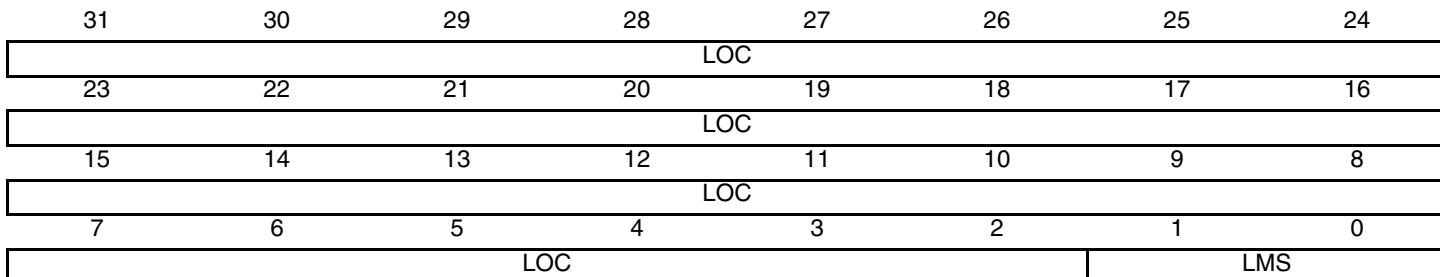

The address offset for each channel is: $0x10+[x * 0x58]$

For example, LLP0: 0x010, LLP1: 0x068, etc.

- **LMS: List Master Select**

Identifies the High speed bus interface for the device that stores the next linked list item.

- **LOC: Address of the next LLI**

Starting address in memory of next LLI if block chaining is enabled.

The user need to program this register to point to the first Linked List Item (LLI) in memory prior to enabling the channel if block chaining is enabled.

The LLP register has two functions:

1. The logical result of the equation $LLP.LOC \neq 0$ is used to set up the type of DMA transfer (single or multi-block). If $LLP.LOC$ is set to 0x0, then transfers using linked lists are NOT enabled. This register must be programmed prior to enabling the channel in order to set up the transfer type. It ($LLP.LOC \neq 0$) contains the pointer to the next Linked Listed Item for block chaining using linked lists.
2. The LLPx register is also used to point to the address where write back of the control and source/destination status information occurs after block completion.

18.10.4 Control Register for Channel x Low

Name: CTLxL

Access: Read/Write

Reset: 0x0

31	30	29	28	27	26	25	24
–	–	–	LLP_S_EN	LLP_D_EN	SMS	DMS	DMS
23	22	21	20	19	18	17	16
DMS	TT_FC			–	–	–	SRC_MSIZ
15	14	13	12	11	10	9	8
SRC_MSIZ		DEST_MSIZ			SINC		DINC
7	6	5	4	3	2	1	0
DINC	SRC_TR_WIDTH			DST_TR_WIDTH			INT_EN

The address offset for each channel is: 0x18+[x * 0x58]

For example, CTL0: 0x018, CTL1: 0x070, etc.

This register contains fields that control the DMA transfer. The CTLxL register is part of the block descriptor (linked list item) when block chaining is enabled. It can be varied on a block-by-block basis within a DMA transfer when block chaining is enabled.

- **INT_EN: Interrupt Enable Bit**

If set, then all five interrupt generating sources are enabled.

- **DST_TR_WIDTH: Destination Transfer Width**

- **SRC_TR_WIDTH: Source Transfer Width**

SRC_TR_WIDTH/DST_TR_WIDTH	Size (bits)
000	8
001	16
010	32
Other	Reserved

- **DINC: Destination Address Increment**

Indicates whether to increment or decrement the destination address on every destination System Bus transfer. If your device is writing data to a destination peripheral FIFO with a fixed address, then set this field to “No change”.

00 = Increment

01 = Decrement

1x = No change

- **SINC: Source Address Increment**

Indicates whether to increment or decrement the source address on every source System Bus transfer. If your device is fetching data from a source peripheral FIFO with a fixed address, then set this field to “No change”.

00 = Increment

01 = Decrement

1x = No change

- **DEST_MSIZ**: Destination Burst Transaction Length

Number of data items, each of width $CTLx.DST_TR_WIDTH$, to be written to the destination every time a destination burst transaction request is made from either the corresponding hardware or software handshaking interface.

- **SRC_MSIZ**: Source Burst Transaction Length

Number of data items, each of width $CTLx.SRC_TR_WIDTH$, to be read from the source every time a source burst transaction request is made from either the corresponding hardware or software handshaking interface.

- **TT_FC**: Transfer Type and Flow Control

The following transfer types are supported.

- Memory to Memory
- Memory to Peripheral
- Peripheral to Memory

Flow Control can be assigned to the DMAC, the source peripheral, or the destination peripheral.

TT_FC	Transfer Type	Flow Controller
000	Memory to Memory	DMAC
001	Memory to Peripheral	DMAC
010	Peripheral to Memory	DMAC
011	Peripheral to Peripheral	DMAC
100	Peripheral to Memory	Peripheral
101	Peripheral to Peripheral	Source Peripheral
110	Memory to Peripheral	Peripheral
111	Peripheral to Peripheral	Destination Peripheral

- **DMS**: Destination Master Select

Identifies the Master Interface layer where the destination device (peripheral or memory) resides.

- 00 = HSB master 1
- 01 = Reserved
- 10 = Reserved
- 11 = Reserved

- **SMS**: Source Master Select

Identifies the Master Interface layer where the source device (peripheral or memory) is accessed from.

- 00 = HSB master 1
- 01 = Reserved
- 10 = Reserved
- 11 = Reserved

- **LLP_D_EN**

Block chaining is only enabled on the destination side if the LLP_D_EN field is high and $LLPx.LOC$ is non-zero.

- **LLP_S_EN**

Block chaining is only enabled on the source side if the *LLP_S_EN* field is high and LLPx.LOC is non-zero.

18.10.5 Control Register for Channel x High

Name: CTLxH

Access: Read/Write

Reset: 0x0

31	30	29	28	27	26	25	24
–	–	–	–	–	–	–	–
23	22	21	20	19	18	17	16
15	14	13	12	11	10	9	8
–	–	–	DONE	BLOCK_TS			
7	6	5	4	3	2	1	0
BLOCK_TS							

- **BLOCK_TS: Block Transfer Size**

When the DMAC is flow controller, this field is written by the user before the channel is enabled to indicate the block size.

The number programmed into BLOCK_TS indicates the total number of single transactions to perform for every block transfer. The width of the single transaction is determined by CTLx.SRC_TR_WIDTH.

- **DONE: Done Bit**

If status writeback is enabled, the control register CTLxH, is written to the control register location of the Linked List Item in system memory at the end of the block transfer with the done bit set.

Software can poll the LLI CTLx.DONE bit to see when a block transfer is complete. The LLI CTLx.DONE bit should be cleared when the linked lists are setup in memory prior to enabling the channel.

18.10.6 Configuration Register for Channel x Low

Name: CFGxL

Access: Read/Write

Reset: 0x0

31	30	29	28	27	26	25	24
RELOAD_DS	RELOAD_SR	MAX_ABRST					
23	22	21	20	19	18	17	16
MAX_ABRST				SR_HS_POL	DS_HS_POL	LOCK_B	LOCK_CH
15	14	13	12	11	10	9	8
LOCK_B_L		LOCK_CH_L		HS_SEL_SR	HS_SEL_DS	FIFO_EMPT	CH_SUSP
7	6	5	4	3	2	1	0
CH_PRIOR			-	-	-	-	-

The address offset for each channel is: $0x40 + [x * 0x58]$

For example, CFG0: 0x040, CFG1: 0x098, etc.

- **CH_PRIOR: Channel priority**

A priority of 7 is the highest priority, and 0 is the lowest. This field must be programmed within the following range $[0, x - 1]$

A programmed value outside this range causes erroneous behavior.

- **CH_SUSP: Channel Suspend**

Suspends all DMA data transfers from the source until this bit is cleared. There is no guarantee that the current transaction will complete. Can also be used in conjunction with CFGx.FIFO_EMPTY to cleanly disable a channel without losing any data.

0 = Not Suspended.

1 = Suspend. Suspend DMA transfer from the source.

- **FIFO_EMPTY**

Indicates if there is data left in the channel's FIFO. Can be used in conjunction with CFGx.CH_SUSP to cleanly disable a channel.

1 = Channel's FIFO empty

0 = Channel's FIFO not empty

- **HS_SEL_DST: Destination Software or Hardware Handshaking Select**

This register selects which of the handshaking interfaces, hardware or software, is active for destination requests on this channel.

0 = Hardware handshaking interface. Software-initiated transaction requests are ignored.

1 = Software handshaking interface. Hardware Initiated transaction requests are ignored.

If the destination peripheral is memory, then this bit is ignored.

- **HS_SEL_SRC: Source Software or Hardware Handshaking Select**

This register selects which of the handshaking interfaces, hardware or software, is active for source requests on this channel.

0 = Hardware handshaking interface. Software-initiated transaction requests are ignored.

1 = Software handshaking interface. Hardware-initiated transaction requests are ignored.

If the source peripheral is memory, then this bit is ignored.

- **LOCK_CH_L: Channel Lock Level**

Indicates the duration over which CFGx.LOCK_CH bit applies.

00 = Over complete DMA transfer

01 = Over complete DMA block transfer

1x = Over complete DMA transaction

- **LOCK_B_L: Bus Lock Level**

Indicates the duration over which CFGx.LOCK_B bit applies.

00 = Over complete DMA transfer

01 = Over complete DMA block transfer

1x = Over complete DMA transaction

- **LOCK_CH: Channel Lock Bit**

When the channel is granted control of the master bus interface and if the CFGx.LOCK_CH bit is asserted, then no other channels are granted control of the master bus interface for the duration specified in CFGx.LOCK_CH_L. Indicates to the master bus interface arbiter that this channel wants exclusive access to the master bus interface for the duration specified in CFGx.LOCK_CH_L.

- **LOCK_B: Bus Lock Bit**

When active, the System Bus master signal hlock is asserted for the duration specified in CFGx.LOCK_B_L.

- **DS_HS_POL: Destination Handshaking Interface Polarity**

0 = Active high

1 = Active low

- **SR_HS_POL: Source Handshaking Interface Polarity**

0 = Active high

1 = Active low

- **MAX_ABRST: Maximum System Bus Burst Length**

Maximum System Bus burst length that is used for DMA transfers on this channel. A value of '0' indicates that software is not limiting the maximum burst length for DMA transfers on this channel.

- **RELOAD_SR: Automatic Source Reload**

The SARx register can be automatically reloaded from its initial value at the end of every block for multi-block transfers. A new block transfer is then initiated.

- **RELOAD_DS: Automatic Destination Reload**

The DARx register can be automatically reloaded from its initial value at the end of every block for multi-block transfers. A new block transfer is then initiated.

18.10.7 Configuration Register for Channel x High

Name: CFGxH

Access: Read/Write

Reset: 0x0

31	30	29	28	27	26	25	24
–	–	–	–	–	–	–	–
23	22	21	20	19	18	17	16
–	–	–	–	–	–	–	–
15	14	13	12	11	10	9	8
–	DEST_PER				SRC_PER		
7	6	5	4	3	2	1	0
SRC_PER	-	-	PROTCTL			FIFO_MODE	FCMODE

- **FCMODE: Flow Control Mode**

Determines when source transaction requests are serviced when the Destination Peripheral is the flow controller.

0 = Source transaction requests are serviced when they occur. Data pre-fetching is enabled.

1 = Source transaction requests are not serviced until a destination transaction request occurs. In this mode the amount of data transferred from the source is limited such that it is guaranteed to be transferred to the destination prior to block termination by the destination. Data pre-fetching is disabled.

- **FIFO_MODE: R/W 0x0 FIFO Mode Select**

Determines how much space or data needs to be available in the FIFO before a burst transaction request is serviced.

0 = Space/data available for single System Bus transfer of the specified transfer width.

1 = Space/data available is greater than or equal to half the FIFO depth for destination transfers and less than half the FIFO depth for source transfers. The exceptions are at the end of a burst transaction request or at the end of a block transfer.

- **PROTCTL: Protection Control**

Bits used to drive the System Bus HPROT[3:1] bus. The *System Bus Specification* recommends that the default value of HPROT indicates a non-cached, nonbuffered, privileged data access. The reset value is used to indicate such an access.

HPROT[0] is tied high as all transfers are data accesses as there are no opcode fetches. There is a one-to-one mapping of these register bits to the HPROT[3:1] master interface signals.

- **SRC_PER: Source Hardware Handshaking Interface**

Assigns a hardware handshaking interface (0 - DMAH_NUM_HS_INT-1) to the source of channel x if the CFGx.HS_SEL_SRC field is 0. Otherwise, this field is ignored. The channel can then communicate with the source peripheral connected to that interface via the assigned hardware handshaking interface.

For correct DMAC operation, only one peripheral (source or destination) should be assigned to the same handshaking interface.

- **DEST_PER: Destination Hardware Handshaking Interface**

Assigns a hardware handshaking interface (0 - DMAH_NUM_HS_INT-1) to the destination of channel x if the CFGx.HS_SEL_DST field is 0. Otherwise, this field is ignored. The channel can then communicate with the destination peripheral connected to that interface via the assigned hardware handshaking interface.

For correct DMA operation, only one peripheral (source or destination) should be assigned to the same handshaking interface.

18.10.8 Interrupt Registers

The following sections describe the registers pertaining to interrupts, their status, and how to clear them. For each channel, there are five types of interrupt sources:

- IntTfr: DMA Transfer Complete Interrupt

This interrupt is generated on DMA transfer completion to the destination peripheral.

- IntBlock: Block Transfer Complete Interrupt

This interrupt is generated on DMA block transfer completion to the destination peripheral.

- IntSrcTran: Source Transaction Complete Interrupt

This interrupt is generated after completion of the last System Bus transfer of the requested single/burst transaction from the handshaking interface on the source side.

If the source for a channel is memory, then that channel never generates a IntSrcTran interrupt and hence the corresponding bit in this field is not set.

- IntDstTran: Destination Transaction Complete Interrupt

This interrupt is generated after completion of the last System Bus transfer of the requested single/burst transaction from the handshaking interface on the destination side.

If the destination for a channel is memory, then that channel never generates the IntDstTran interrupt and hence the corresponding bit in this field is not set.

- IntErr: Error Interrupt

This interrupt is generated when an ERROR response is received from an HSB slave on the HRESP bus during a DMA transfer. In addition, the DMA transfer is cancelled and the channel is disabled.

18.10.9 Interrupt Raw Status Registers

Name: RawTfr, RawBlock, RawSrcTran, RawDstTran, RawErr

Access: Read

Reset: 0x0

31	30	29	28	27	26	25	24
–	–	–	–	–	–	–	–
23	22	21	20	19	18	17	16
–	–	–	–	–	–	–	–
15	14	13	12	11	10	9	8
–	–	–	–	–	–	–	–
7	6	5	4	3	2	1	0
–	–	–	–	–	RAW2	RAW1	RAW0

The address offset are

RawTfr – 0x2c0

RawBlock – 0x2c8

RawSrcTran – 0x2d0

RawDstTran – 0x2d8

RawErr – 0x2e0

- **RAW[2:0]:** Raw interrupt for each channel

Interrupt events are stored in these Raw Interrupt Status Registers before masking: RawTfr, RawBlock, RawSrcTran, RawDstTran, RawErr. Each Raw Interrupt Status register has a bit allocated per channel, for example, RawTfr[2] is Channel 2's raw transfer complete interrupt. Each bit in these registers is cleared by writing a 1 to the corresponding location in the ClearTfr, ClearBlock, ClearSrcTran, ClearDstTran, ClearErr registers.

18.10.10 Interrupt Status Registers

Name: StatusTfr, StatusBlock, StatusSrcTran, StatusDstTran, StatusErr

Access: Read

Reset: 0x0

31	30	29	28	27	26	25	24
–	–	–	–	–	–	–	–
23	22	21	20	19	18	17	16
–	–	–	–	–	–	–	–
15	14	13	12	11	10	9	8
–	–	–	–	–	–	–	–
7	6	5	4	3	2	1	0
–	–	–	–	–	STATUS2	STATUS1	STATUS0

The address offset are

StatusTfr: 0x2e8

StatusBlock: 0x2f0

StatusSrcTran: 0x2f8

StatusDstTran: 0x300

StatusErr: 0x308

- **STATUS[2:0]**

All interrupt events from all channels are stored in these Interrupt Status Registers after masking: StatusTfr, StatusBlock, StatusSrcTran, StatusDstTran, StatusErr. Each Interrupt Status register has a bit allocated per channel, for example, StatusTfr[2] is Channel 2's status transfer complete interrupt. The contents of these registers are used to generate the interrupt signals leaving the DMAC.

18.10.11 Interrupt Status Registers

Name: MaskTfr, MaskBlock, MaskSrcTran, MaskDstTran, MaskErr

Access: Read/Write

Reset: 0x0

31	30	29	28	27	26	25	24
–	–	–	–	–	–	–	–
23	22	21	20	19	18	17	16
–	–	–	–	–	–	–	–
15	14	13	12	11	10	9	8
–	–	–	–	–	INT_M_WE2	INT_M_WE1	INT_M_WE0
7	6	5	4	3	2	1	0
–	–	–	–	–	INT_MASK2	INT_MASK1	INT_MASK0

The address offset are

MaskTfr: 0x310

MaskBlock: 0x318

MaskSrcTran: 0x320

MaskDstTran: 0x328

MaskErr: 0x330

The contents of the Raw Status Registers are masked with the contents of the Mask Registers: MaskTfr, MaskBlock, MaskSrcTran, MaskDstTran, MaskErr. Each Interrupt Mask register has a bit allocated per channel, for example, MaskTfr[2] is the mask bit for Channel 2's transfer complete interrupt.

A channel's INT_MASK bit is only written if the corresponding mask write enable bit in the INT_MASK_WE field is asserted on the same System Bus write transfer. This allows software to set a mask bit without performing a read-modified write operation.

For example, writing hex 01x1 to the MaskTfr register writes a 1 into MaskTfr[0], while MaskTfr[7:1] remains unchanged. Writing hex 00xx leaves MaskTfr[7:0] unchanged.

Writing a 1 to any bit in these registers unmask the corresponding interrupt, thus allowing the DMAC to set the appropriate bit in the Status Registers.

- **INT_MASK[2:0]: Interrupt Mask**

0 = Masked

1 = Unmasked

- **INT_M_WE[10:8]: Interrupt Mask Write Enable**

0 = Write disabled

1 = Write enabled

18.10.12 Interrupt Clear Registers

Name: ClearTfr, ClearBlock, ClearSrcTran, ClearDstTran, ClearErr

Access: Write

Reset: 0x0

31	30	29	28	27	26	25	24
–	–	–	–	–	–	–	–
23	22	21	20	19	18	17	16
–	–	–	–	–	–	–	–
15	14	13	12	11	10	9	8
–	–	–	–	–	–	–	–
7	6	5	4	3	2	1	0
–	–	–	–	–	CLEAR2	CLEAR1	CLEAR0

The address offset are

ClearTfr: 0x338

ClearBlock: 0x340

ClearSrcTran: 0x348

ClearDstTran: 0x350

ClearErr: 0x358

• **CLEAR[2:0]: Interrupt Clear**

0 = No effect

1 = Clear interrupt

Each bit in the Raw Status and Status registers is cleared on the same cycle by writing a 1 to the corresponding location in the Clear registers: ClearTfr, ClearBlock, ClearSrcTran, ClearDstTran, ClearErr. Each Interrupt Clear register has a bit allocated per channel, for example, ClearTfr[2] is the clear bit for Channel 2’s transfer complete interrupt. Writing a 0 has no effect. These registers are not readable.

18.10.13 Combined Interrupt Status Registers

Name: StatusInt

Access: Read

Reset: 0x0

31	30	29	28	27	26	25	24
–	–	–	–	–	–	–	–
23	22	21	20	19	18	17	16
–	–	–	–	–	–	–	–
15	14	13	12	11	10	9	8
–	–	–	–	–	–	–	–
7	6	5	4	3	2	1	0
–	–	–	ERR	DSTT	SRCT	BLOCK	TFR

The contents of each of the five Status Registers (StatusTfr, StatusBlock, StatusSrcTran, StatusDstTran, StatusErr) is OR'd to produce a single bit per interrupt type in the Combined Status Register (StatusInt).

- **TFR**

OR of the contents of StatusTfr Register.

- **BLOCK**

OR of the contents of StatusBlock Register.

- **SRCT**

OR of the contents of StatusSrcTran Register.

- **DSTT**

OR of the contents of StatusDstTran Register.

- **ERR**

OR of the contents of StatusErr Register.

18.10.14 Source Software Transaction Request Register

Name: ReqSrcReg

Access: Read/write

Reset: 0x0

31	30	29	28	27	26	25	24
–	–	–	–	–	–	–	–
23	22	21	20	19	18	17	16
–	–	–	–	–	–	–	–
15	14	13	12	11	10	9	8
–	–	–	–	–	REQ_WE2	REQ_WE1	REQ_WE0
7	6	5	4	3	2	1	0
–	–	–	–	–	SRC_REQ2	SRC_REQ1	SRC_REQ0

A bit is assigned for each channel in this register. ReqSrcReg[*n*] is ignored when software handshaking is not enabled for the source of channel *n*.

A channel SRC_REQ bit is written only if the corresponding channel write enable bit in the REQ_WE field is asserted on the same System Bus write transfer.

For example, writing 0x101 writes a 1 into ReqSrcReg[0], while ReqSrcReg[3:1] remains unchanged. Writing hex 0x0yy leaves ReqSrcReg[3:0] unchanged. This allows software to set a bit in the ReqSrcReg register without performing a read-modified write

- **SRC_REQ[2:0]: Source request**
- **REQ_WE[10:8]: Request write enable**

0 = Write disabled

1 = Write enabled

18.10.15 Destination Software Transaction Request Register

Name: ReqDstReg

Access: Read/write

Reset: 0x0

31	30	29	28	27	26	25	24
–	–	–	–	–	–	–	–
23	22	21	20	19	18	17	16
–	–	–	–	–	–	–	–
15	14	13	12	11	10	9	8
–	–	–	–	–	REQ_WE2	REQ_WE1	REQ_WE0
7	6	5	4	3	2	1	0
–	–	–	–	–	DST_REQ2	DST_REQ1	DST_REQ0

A bit is assigned for each channel in this register. ReqDstReg[*n*] is ignored when software handshaking is not enabled for the source of channel *n*.

A channel DST_REQ bit is written only if the corresponding channel write enable bit in the REQ_WE field is asserted on the same System Bus write transfer.

- **DST_REQ[2:0]: Destination request**
- **REQ_WE[10:8]: Request write enable**

0 = Write disabled

1 = Write enabled

18.10.16 Single Source Transaction Request Register

Name: SglReqSrcReg

Access: Read/write

Reset: 0x0

31	30	29	28	27	26	25	24
–	–	–	–	–	–	–	–
23	22	21	20	19	18	17	16
–	–	–	–	–	–	–	–
15	14	13	12	11	10	9	8
–	–	–	–	–	REQ_WE2	REQ_WE1	REQ_WE0
7	6	5	4	3	2	1	0
–	–	–	–	–	S_SG_REQ2	S_SG_REQ1	S_SG_REQ0

A bit is assigned for each channel in this register. SglReqSrcReg[*n*] is ignored when software handshaking is not enabled for the source of channel *n*.

A channel S_SG_REQ bit is written only if the corresponding channel write enable bit in the REQ_WE field is asserted on the same System Bus write transfer.

- **S_SG_REQ[2:0]: Source single request**

- **REQ_WE[10:8]: Request write enable**

0 = Write disabled

1 = Write enabled

18.10.17 Single Destination Transaction Request Register

Name: SglReqDstReg

Access: Read/write

Reset: 0x0

31	30	29	28	27	26	25	24
–	–	–	–	–	–	–	–
23	22	21	20	19	18	17	16
–	–	–	–	–	–	–	–
15	14	13	12	11	10	9	8
–	–	–	–	–	REQ_WE2	REQ_WE1	REQ_WE0
7	6	5	4	3	2	1	0
–	–	–	–	–	D_SG_REQ2	D_SG_REQ1	D_SG_REQ0

A bit is assigned for each channel in this register. SglReqDstReg[*n*] is ignored when software handshaking is not enabled for the source of channel *n*.

A channel D_SG_REQ bit is written only if the corresponding channel write enable bit in the REQ_WE field is asserted on the same System Bus write transfer.

- **D_SG_REQ[2:0]: Destination single request**

- **REQ_WE[10:8]: Request write enable**

0 = Write disabled

1 = Write enabled

18.10.18 Last Source Transaction Request Register

Name: LstSrcReqReg

Access: Read/write

Reset: 0x0

31	30	29	28	27	26	25	24
–	–	–	–	–	–	–	–
23	22	21	20	19	18	17	16
–	–	–	–	–	–	–	–
15	14	13	12	11	10	9	8
–	–	–	–	–	LSTSR_WE2	LSTSR_WE1	LSTSR_WE0
7	6	5	4	3	2	1	0
–	–	–	–	–	LSTSRC2	LSTSRC1	LSTSRC0

A bit is assigned for each channel in this register. LstSrcReqReg[*n*] is ignored when software handshaking is not enabled for the source of channel *n*.

A channel LSTSRC bit is written only if the corresponding channel write enable bit in the LSTSR_WE field is asserted on the same System Bus write transfer.

- **LSTSRC[2:0]: Source Last Transaction request**
- **LSTSR_WE[10:8]: Source Last Transaction request write enable**

0 = Write disabled

1 = Write enabled

18.10.19 Last Destination Transaction Request Register

Name: LstDstReqReg

Access: Read/write

Reset: 0x0

31	30	29	28	27	26	25	24
–	–	–	–	–	–	–	–
23	22	21	20	19	18	17	16
–	–	–	–	–	–	–	–
15	14	13	12	11	10	9	8
–	–	–	–	–	LSTDS_WE2	LSTDS_WE1	LSTDS_WE0
7	6	5	4	3	2	1	0
–	–	–	–	–	LSTDST2	LSTDST1	LSTDST0

A bit is assigned for each channel in this register. LstDstReqReg[*n*] is ignored when software handshaking is not enabled for the source of channel *n*.

A channel LSTDST bit is written only if the corresponding channel write enable bit in the LSTDS_WE field is asserted on the same System Bus write transfer.

- **LSTDST[2:0]: Destination Last Transaction request**
- **LSTDS_WE[10:8]: Destination Last Transaction request write enable**

0 = Write disabled

1 = Write enabled

18.10.20 DMAC Configuration Register

Name: DmaCfgReg

Access: Read/Write

Reset: 0x0

31	30	29	28	27	26	25	24
–	–	–	–	–	–	–	–
23	22	21	20	19	18	17	16
–	–	–	–	–	–	–	–
15	14	13	12	11	10	9	8
–	–	–	–	–	–	–	–
7	6	5	4	3	2	1	0
–	–	–	–	–	–	–	DMA_EN

- **DMA_EN:** DMA Controller Enable

0 = DMAC Disabled

1 = DMAC Enabled.

This register is used to enable the DMAC, which must be done before any channel activity can begin.

If the global channel enable bit is cleared while any channel is still active, then DmaCfgReg.DMA_EN still returns '1' to indicate that there are channels still active until hardware has terminated all activity on all channels, at which point the DmaCfgReg.DMA_EN bit returns '0'.

18.10.21 DMAC Channel Enable Register

Name: ChEnReg

Access: Read/Write

Reset: 0x0

31	30	29	28	27	26	25	24
–	–	–	–	–	–	–	–
23	22	21	20	19	18	17	16
–	–	–	–	–	–	–	–
15	14	13	12	11	10	9	8
–	–	–	–	–	CH_EN_WE2	CH_EN_WE1	CH_EN_WE0
7	6	5	4	3	2	1	0
–	–	–	–	–	CH_EN2	CH_EN1	CH_EN0

- **CH_EN[2:0]**

0 = Disable the Channel

1 = Enable the Channel

Enables/Disables the channel. Setting this bit enables a channel, clearing this bit disables the channel.

The ChEnReg.CH_EN bit is automatically cleared by hardware to disable the channel after the last System Bus transfer of the DMA transfer to the destination has completed. Software can therefore poll this bit to determine when a DMA transfer has completed.

- **CH_EN_WE[10:8]**

The channel enable bit, CH_EN, is only written if the corresponding channel write enable bit, CH_EN_WE, is asserted on the same System Bus write transfer.

For example, writing 0x101 writes a 1 into ChEnReg[0], while ChEnReg[7:1] remains unchanged.

19. Peripheral DMA Controller (PDC)

Rev: 6047C

19.1 Features

- **Generates Transfers to/from Peripherals such as USART, SSC and SPI**
- **Supports Up to 20 Channels (Product Dependent)**
- **One Master Clock Cycle Needed for a Transfer from Memory to Peripheral**
- **Two Master Clock Cycles Needed for a Transfer from Peripheral to Memory**

19.2 Description

The Peripheral DMA Controller (PDC) transfers data between on-chip serial peripherals such as the UART, USART, SSC, SPI, and the on- and off-chip memories. Using the Peripheral DMA Controller avoids processor intervention and removes the processor interrupt-handling overhead. This significantly reduces the number of clock cycles required for a data transfer and, as a result, improves the performance of the microcontroller and makes it more power efficient.

The PDC channels are implemented in pairs, each pair being dedicated to a particular peripheral. One channel in the pair is dedicated to the receiving channel and one to the transmitting channel of each UART, USART, SSC and SPI.

The user interface of a PDC channel is integrated in the memory space of each peripheral. It contains:

- A 32-bit memory pointer register
- A 16-bit transfer count register
- A 32-bit register for next memory pointer
- A 16-bit register for next transfer count

The peripheral triggers PDC transfers using transmit and receive signals. When the programmed data is transferred, an end of transfer interrupt is generated by the corresponding peripheral.

19.3 Block Diagram

Figure 19-1. Block Diagram

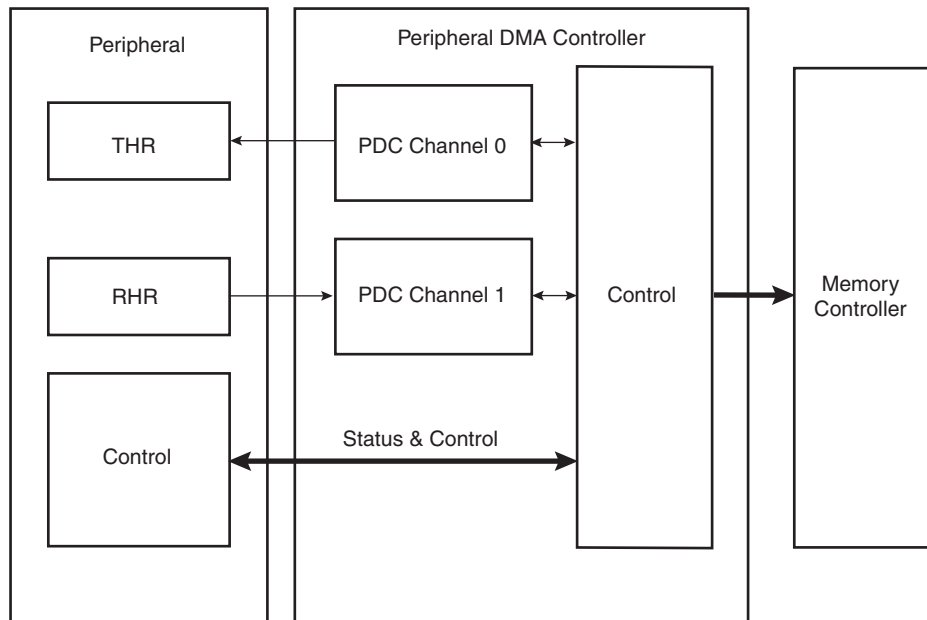

19.4 Functional Description

19.4.1 Configuration

The PDC channels user interface enables the user to configure and control the data transfers for each channel. The user interface of a PDC channel is integrated into the user interface of the peripheral (offset 0x100), which it is related to.

Per peripheral, it contains four 32-bit Pointer Registers (RPR, RNPR, TPR, and TNPR) and four 16-bit Counter Registers (RCR, RNCR, TCR, and TNCR).

The size of the buffer (number of transfers) is configured in an internal 16-bit transfer counter register, and it is possible, at any moment, to read the number of transfers left for each channel.

The memory base address is configured in a 32-bit memory pointer by defining the location of the first address to access in the memory. It is possible, at any moment, to read the location in memory of the next transfer and the number of remaining transfers. The PDC has dedicated status registers which indicate if the transfer is enabled or disabled for each channel. The status for each channel is located in the peripheral status register. Transfers can be enabled and/or disabled by setting TXTEN/TXTDIS and RXTEN/RXTDIS in PDC Transfer Control Register. These control bits enable reading the pointer and counter registers safely without any risk of their changing between both reads.

The PDC sends status flags to the peripheral visible in its status-register (ENDRX, ENDTX, RXBUFF, and TXBUFE).

ENDRX flag is set when the PERIPH_RCR register reaches zero.

RXBUFF flag is set when both PERIPH_RCR and PERIPH_RNCR reach zero.

ENDTX flag is set when the PERIPH_TCR register reaches zero.

TXBUFE flag is set when both PERIPH_TCR and PERIPH_TNCR reach zero.

These status flags are described in the peripheral status register.

19.4.2 Memory Pointers

Each peripheral is connected to the PDC by a receiver data channel and a transmitter data channel. Each channel has an internal 32-bit memory pointer. Each memory pointer points to a location anywhere in the memory space (on-chip memory or external bus interface memory).

Depending on the type of transfer (byte, half-word or word), the memory pointer is incremented by 1, 2 or 4, respectively for peripheral transfers.

If a memory pointer is reprogrammed while the PDC is in operation, the transfer address is changed, and the PDC performs transfers using the new address.

19.4.3 Transfer Counters

There is one internal 16-bit transfer counter for each channel used to count the size of the block already transferred by its associated channel. These counters are decremented after each data transfer. When the counter reaches zero, the transfer is complete and the PDC stops transferring data.

If the Next Counter Register is equal to zero, the PDC disables the trigger while activating the related peripheral end flag.

If the counter is reprogrammed while the PDC is operating, the number of transfers is updated and the PDC counts transfers from the new value.

Programming the Next Counter/Pointer registers chains the buffers. The counters are decremented after each data transfer as stated above, but when the transfer counter reaches zero, the values of the Next Counter/Pointer are loaded into the Counter/Pointer registers in order to re-enable the triggers.

For each channel, two status bits indicate the end of the current buffer (ENDRX, ENTX) and the end of both current and next buffer (RXBUFF, TXBUFE). These bits are directly mapped to the peripheral status register and can trigger an interrupt request to the Interrupt Controller.

The peripheral end flag is automatically cleared when one of the counter-registers (Counter or Next Counter Register) is written.

Note: When the Next Counter Register is loaded into the Counter Register, it is set to zero.

19.4.4 Data Transfers

The peripheral triggers PDC transfers using transmit (TXRDY) and receive (RXRDY) signals.

When the peripheral receives an external character, it sends a Receive Ready signal to the PDC which then requests access to the system bus. When access is granted, the PDC starts a read of the peripheral Receive Holding Register (RHR) and then triggers a write in the memory.

After each transfer, the relevant PDC memory pointer is incremented and the number of transfers left is decremented. When the memory block size is reached, a signal is sent to the peripheral and the transfer stops.

The same procedure is followed, in reverse, for transmit transfers.

19.4.5 Priority of PDC Transfer Requests

The Peripheral DMA Controller handles transfer requests from the channel according to priorities fixed for each product. These priorities are defined in the product datasheet.

If simultaneous requests of the same type (receiver or transmitter) occur on identical peripherals, the priority is determined by the numbering of the peripherals.

If transfer requests are not simultaneous, they are treated in the order they occurred. Requests from the receivers are handled first and then followed by transmitter requests.

19.5 Peripheral DMA Controller (PDC) User Interface

Table 19-1. Register Mapping

Offset	Register	Register Name	Read/Write	Reset
0x100	Receive Pointer Register	PERIPH ⁽¹⁾ _RPR	Read/Write	0x0
0x104	Receive Counter Register	PERIPH_RCR	Read/Write	0x0
0x108	Transmit Pointer Register	PERIPH_TPR	Read/Write	0x0
0x10C	Transmit Counter Register	PERIPH_TCR	Read/Write	0x0
0x110	Receive Next Pointer Register	PERIPH_RNPR	Read/Write	0x0
0x114	Receive Next Counter Register	PERIPH_RNCR	Read/Write	0x0
0x118	Transmit Next Pointer Register	PERIPH_TNPR	Read/Write	0x0
0x11C	Transmit Next Counter Register	PERIPH_TNCR	Read/Write	0x0
0x120	PDC Transfer Control Register	PERIPH_PTCR	Write-only	-
0x124	PDC Transfer Status Register	PERIPH_PTSR	Read-only	0x0

Note: 1. PERIPH: Ten registers are mapped in the peripheral memory space at the same offset. These can be defined by the user according to the function and the peripheral desired (USART, SSC, SPI, etc).

19.5.1 PDC Receive Pointer Register

Register Name: PERIPH_RPR

Access Type: Read/Write

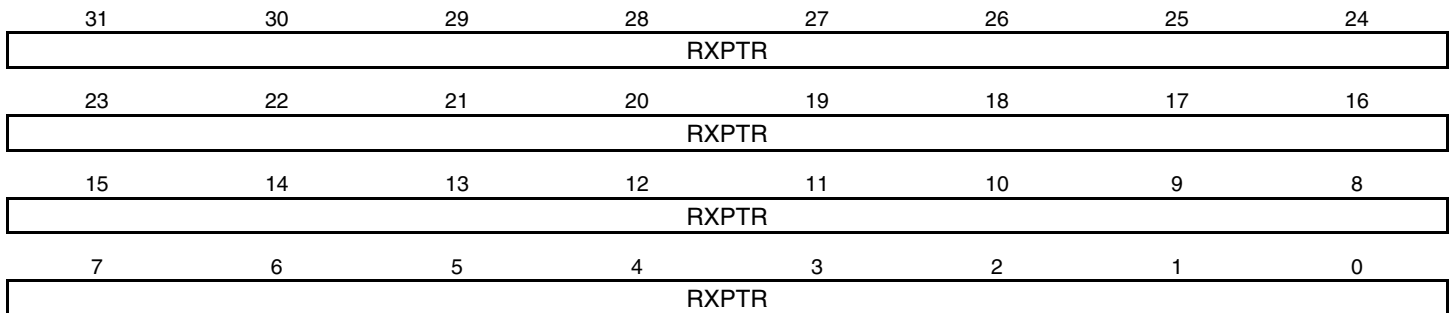

- **RXPTR: Receive Pointer Address**

Address of the next receive transfer.

19.5.2 PDC Receive Counter Register

Register Name: PERIPH_RCR

Access Type: Read/Write

31	30	29	28	27	26	25	24
--							
23	22	21	20	19	18	17	16
--							
15	14	13	12	11	10	9	8
RXCTR							
7	6	5	4	3	2	1	0
RXCTR							

- **RXCTR: Receive Counter Value**

Number of receive transfers to be performed.

19.5.3 PDC Transmit Pointer Register

Register Name: PERIPH_TPR

Access Type: Read/Write

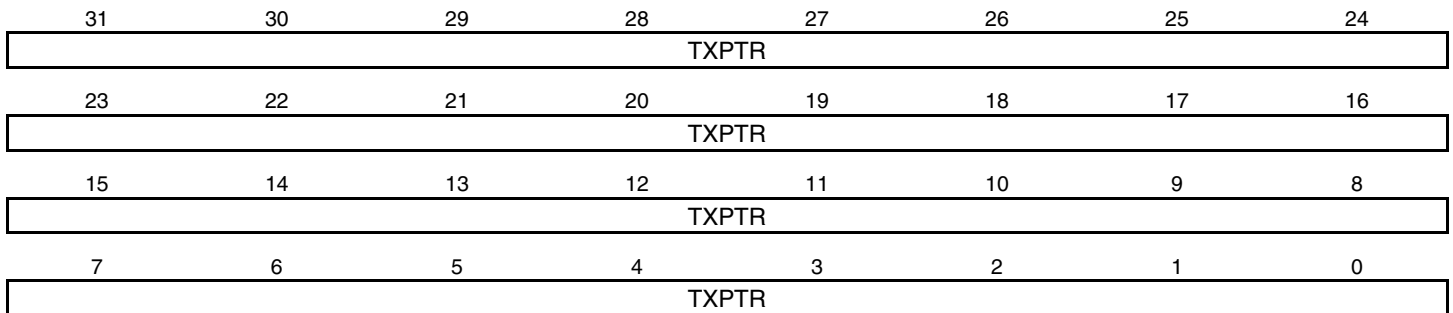

- **TXPTR: Transmit Pointer Address**

Address of the transmit buffer.

19.5.4 PDC Transmit Counter Register

Register Name: PERIPH_TCR

Access Type: Read/Write

31	30	29	28	27	26	25	24
--							
23	22	21	20	19	18	17	16
--							
15	14	13	12	11	10	9	8
TXCTR							
7	6	5	4	3	2	1	0
TXCTR							

- **TXCTR: Transmit Counter Value**

TXCTR is the size of the transmit transfer to be performed. At zero, the peripheral data transfer is stopped.

19.5.5 PDC Receive Next Pointer Register

Register Name: PERIPH_RNPR

Access Type: Read/Write

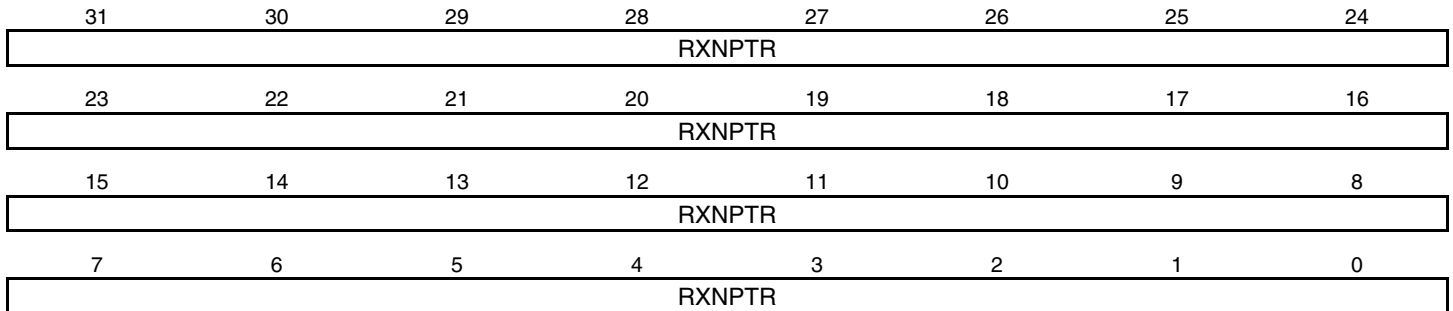

- **RXNPTR: Receive Next Pointer Address**

RXNPTR is the address of the next buffer to fill with received data when the current buffer is full.

19.5.6 PDC Receive Next Counter Register

Register Name: PERIPH_RNCR

Access Type: Read/Write

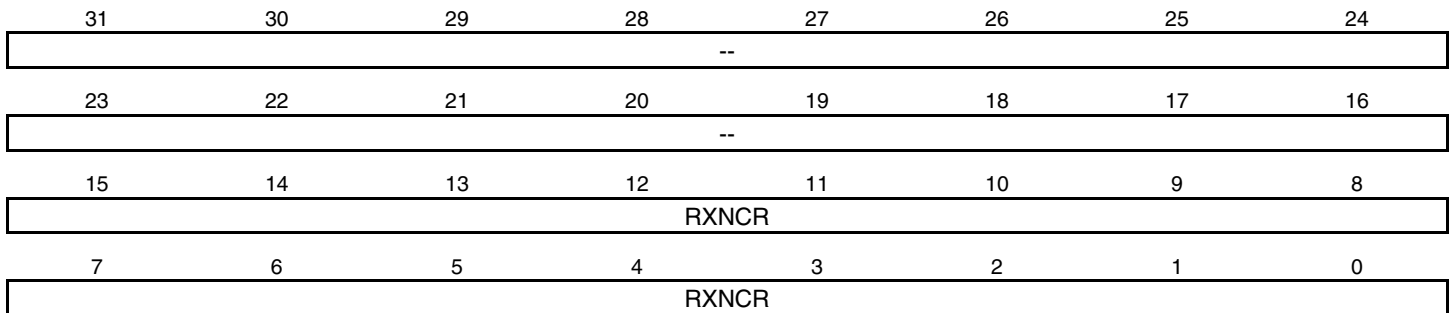

- **RXNCR: Receive Next Counter Value**

RXNCR is the size of the next buffer to receive.

19.5.7 PDC Transmit Next Pointer Register

Register Name: PERIPH_TNPR

Access Type: Read/Write

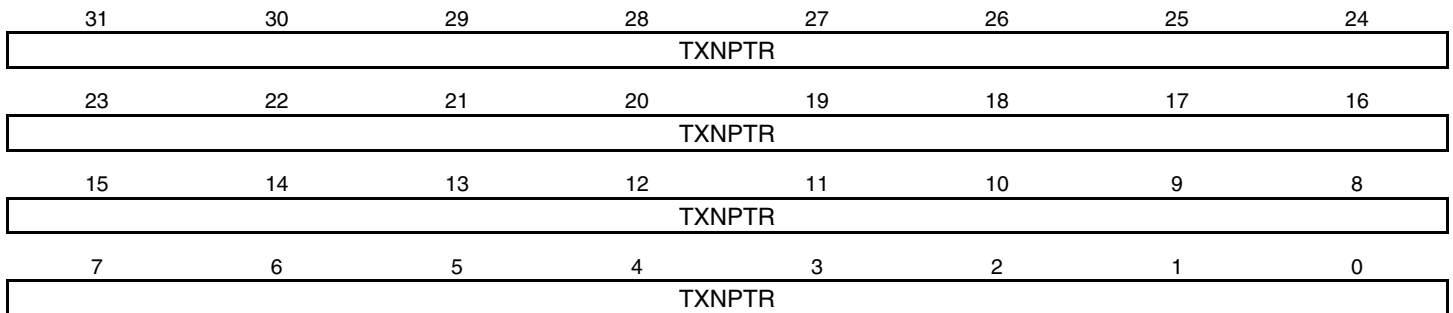

- **TXNPTR: Transmit Next Pointer Address**

TXNPTR is the address of the next buffer to transmit when the current buffer is empty.

19.5.8 PDC Transmit Next Counter Register

Register Name: PERIPH_TNCR

Access Type: Read/Write

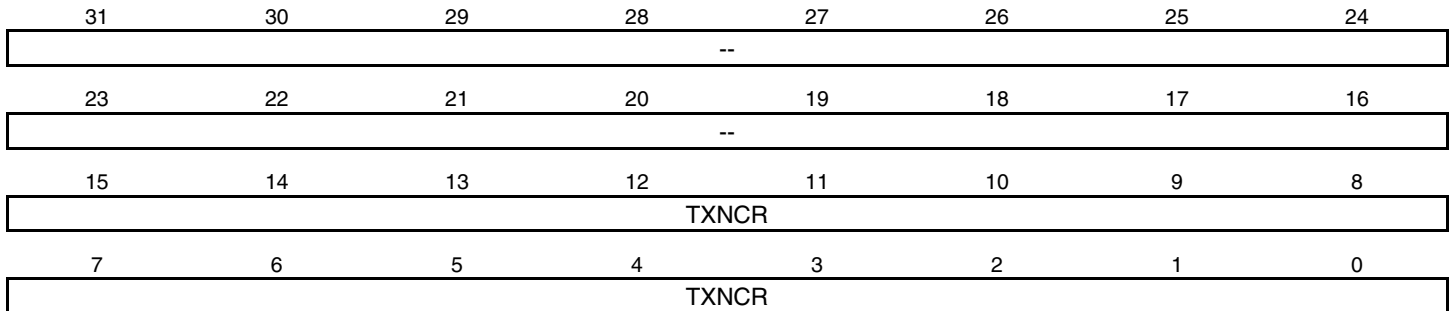

- **TXNCR: Transmit Next Counter Value**

TXNCR is the size of the next buffer to transmit.

19.5.9 PDC Transfer Control Register

Register Name: PERIPH_PTCR

Access Type: Write-only

31	30	29	28	27	26	25	24
–	–	–	–	–	–	–	–
23	22	21	20	19	18	17	16
–	–	–	–	–	–	–	–
15	14	13	12	11	10	9	8
–	–	–	–	–	–	TXTDIS	TXTEN
7	6	5	4	3	2	1	0
–	–	–	–	–	–	RXTDIS	RXTEN

- **RXTEN: Receiver Transfer Enable**

0 = No effect.

1 = Enables the receiver PDC transfer requests if RXTDIS is not set.

- **RXTDIS: Receiver Transfer Disable**

0 = No effect.

1 = Disables the receiver PDC transfer requests.

- **TXTEN: Transmitter Transfer Enable**

0 = No effect.

1 = Enables the transmitter PDC transfer requests.

- **TXTDIS: Transmitter Transfer Disable**

0 = No effect.

1 = Disables the transmitter PDC transfer requests

19.5.10 PDC Transfer Status Register

Register Name: PERIPH_PTSR

Access Type: Read-only

31	30	29	28	27	26	25	24
–	–	–	–	–	–	–	–
23	22	21	20	19	18	17	16
–	–	–	–	–	–	–	–
15	14	13	12	11	10	9	8
–	–	–	–	–	–	–	TXTEN
7	6	5	4	3	2	1	0
–	–	–	–	–	–	–	RXTEN

- **RXTEN: Receiver Transfer Enable**

0 = Receiver PDC transfer requests are disabled.

1 = Receiver PDC transfer requests are enabled.

- **TXTEN: Transmitter Transfer Enable**

0 = Transmitter PDC transfer requests are disabled.

1 = Transmitter PDC transfer requests are enabled.

20. Parallel Input/Output Controller (PIO)

Rev: 2.0.2.0

20.1 Features

- Up to 32 Programmable I/O Lines
- Fully Programmable through Set/Clear Registers
- Multiplexing of Two Peripheral Functions per I/O Line
- For each I/O Line (Whether Assigned to a Peripheral or Used as General Purpose I/O)
 - Input Change Interrupt
 - Glitch Filter
 - Programmable Pull Up on Each I/O Line
 - Pin Data Status Register, Supplies Visibility of the Level on the Pin at Any Time
- Synchronous Output, Provides Set and Clear of Several I/O lines in a Single Write

20.2 Description

The Parallel Input/Output Controller (PIO) manages up to 32 fully programmable input/output lines. Each I/O line may be dedicated as a general-purpose I/O or be assigned to a function of an embedded peripheral. This assures effective optimization of the pins of a product.

Each I/O line is associated with a bit number in all of the 32-bit registers of the 32-bit wide User Interface.

Each I/O line of the PIO Controller features:

- An input change interrupt enabling level change detection on any I/O line.
- A glitch filter providing rejection of pulses lower than one-half of clock cycle.
- Control of the the pull-up of the I/O line.
- Input visibility and output control.

The PIO Controller also features a synchronous output providing up to 32 bits of data output in a single write operation.

20.3 Block Diagram

Figure 20-1. Block Diagram

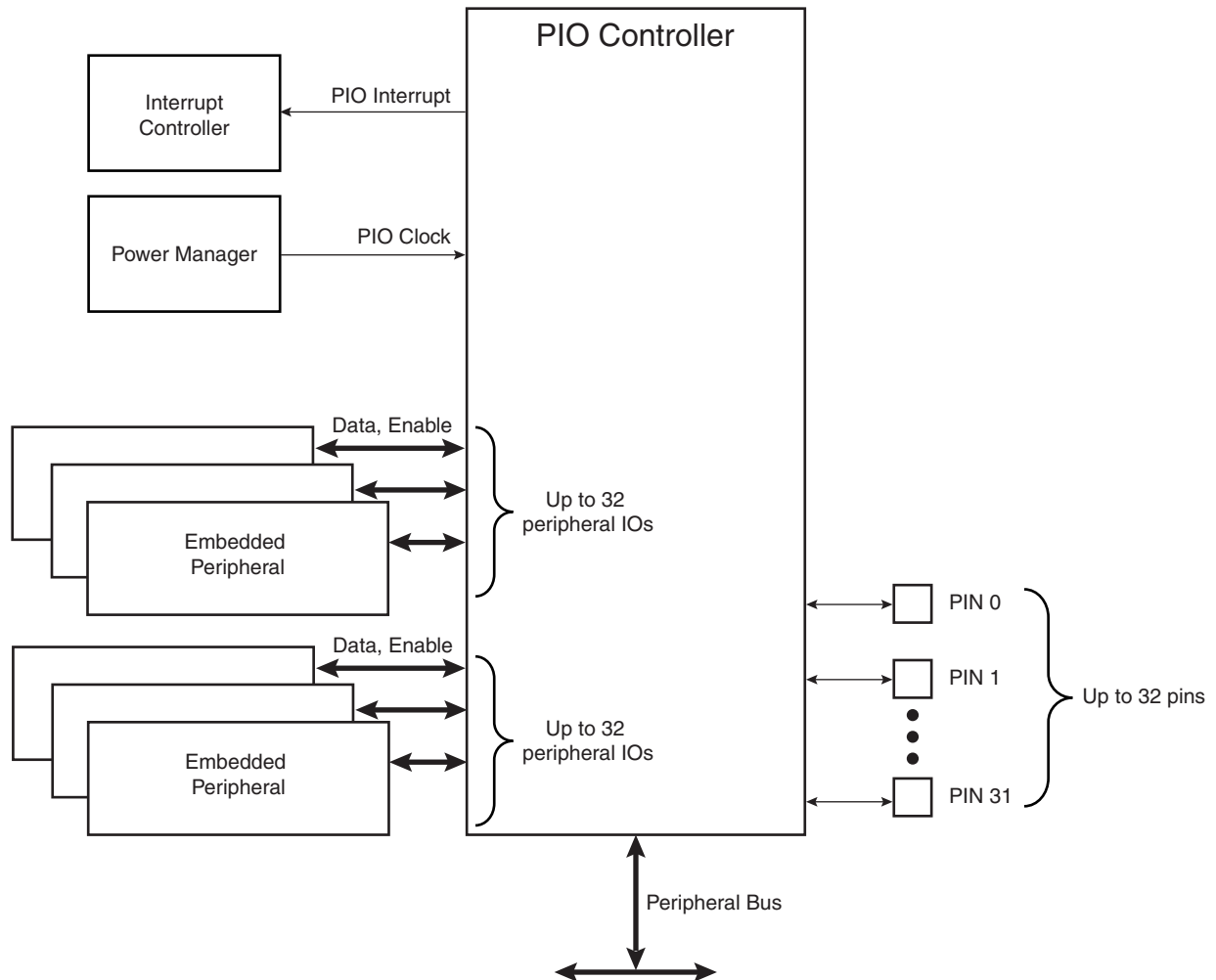
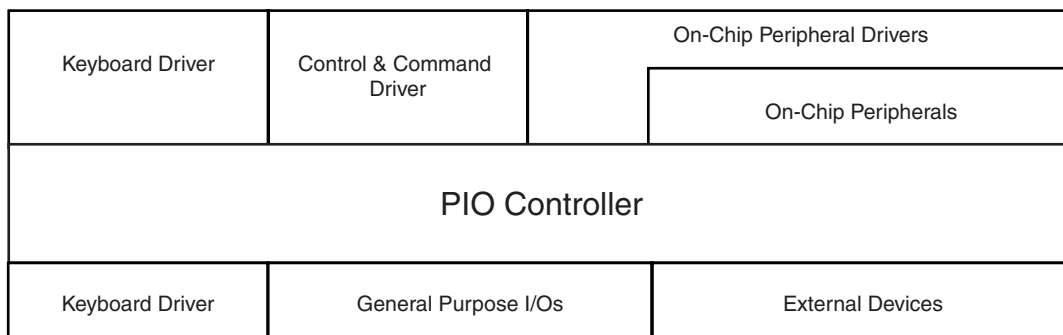

Figure 20-2. Application Block Diagram



20.4 Product Dependencies

20.4.1 Pin Multiplexing

Each pin is configurable, according to product definition as either a general-purpose I/O line only, or as an I/O line multiplexed with one or two peripheral I/Os. As the multiplexing is hardware-defined and thus product-dependent, the hardware designer and programmer must carefully determine the configuration of the PIO controllers required by their application. When an I/O line is general-purpose only, i.e. not multiplexed with any peripheral I/O, programming of the PIO Controller regarding the assignment to a peripheral has no effect and only the PIO Controller can control how the pin is driven by the product.

20.4.2 External Interrupt Lines

The external interrupt request signals are most generally multiplexed through the PIO Controllers. However, it is not necessary to assign the I/O line to the interrupt function as the PIO Controller has no effect on inputs and the external interrupt lines are used only as inputs.

20.4.3 Power Management

The PIO clock is generated by the Power Manager. Before accessing the PIO, the programmer must ensure that the PIO clock is enabled in the Power Manager. Note that the PIO clock must be enabled when using the Input Change interrupt.

In the PIO description, Master Clock (MCK) is the clock of the peripheral bus to which the PIO is connected.

20.4.4 Interrupt Generation

The PIO interrupt line is connected to the Interrupt Controller. Using the PIO interrupt requires the Interrupt Controller to be programmed first.

20.5 Functional Description

The PIO Controller features up to 32 fully-programmable I/O lines. Most of the control logic associated to each I/O is represented in [Figure 20-3](#). In this description each signal shown represents but one of up to 32 possible indexes.

Figure 20-3. I/O Line Control Logic

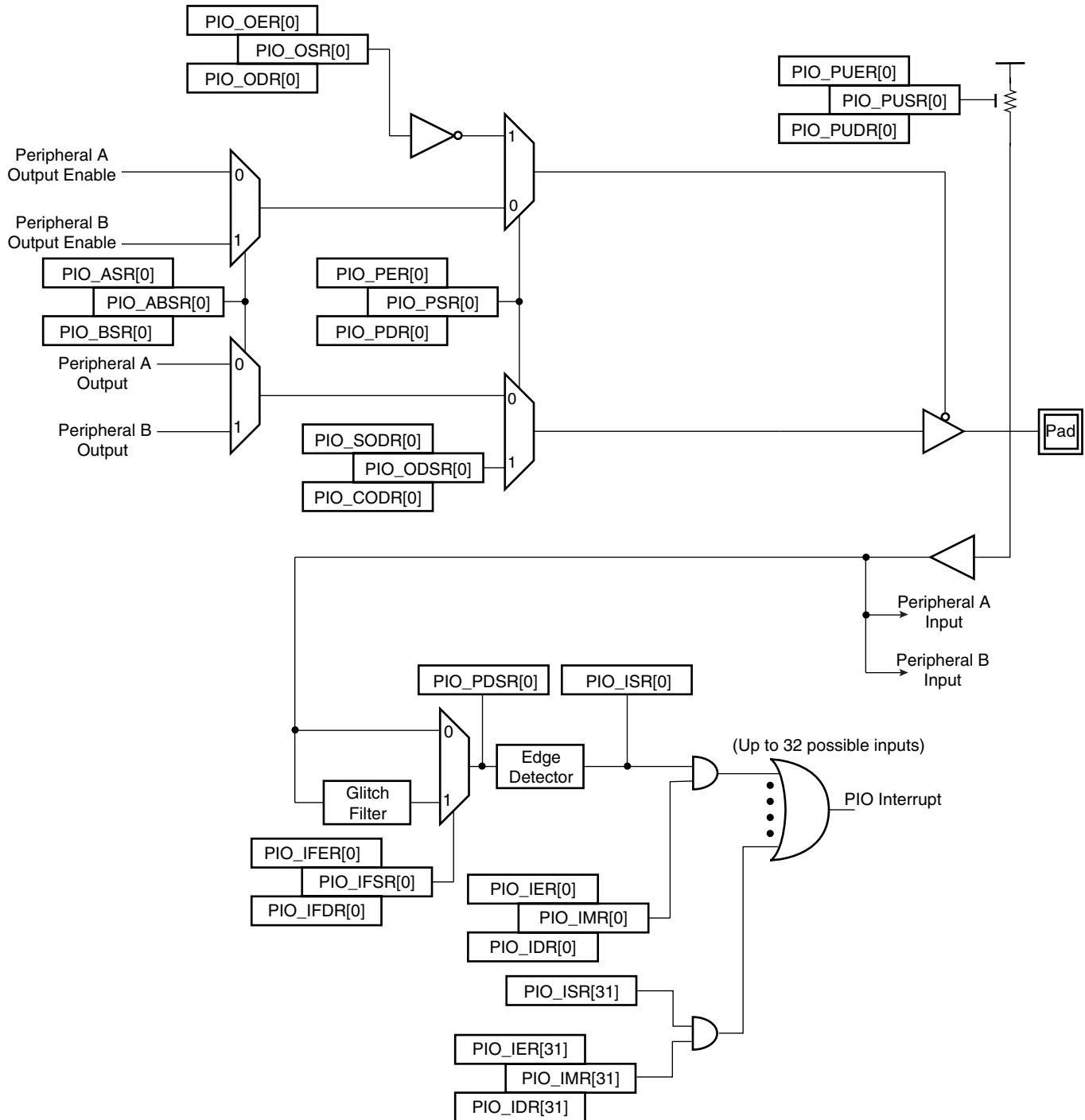

20.5.1 Pull-up Resistor Control

Each I/O line is designed with an embedded pull-up resistor. The pull-up resistor can be enabled or disabled by writing respectively PUER (Pull-up Enable Register) and PUDR (Pull-up Disable Register). Writing in these registers results in setting or clearing the corresponding bit in PUSR (Pull-up Status Register). Reading a 1 in PUSR means the pull-up is disabled and reading a 0 means the pull-up is enabled.

Control of the pull-up resistor is possible regardless of the configuration of the I/O line.

After reset, all of the pull-ups are enabled, i.e. PUSR resets at the value 0x0.

20.5.2 I/O Line or Peripheral Function Selection

When a pin is multiplexed with one or two peripheral functions, the selection is controlled with the registers PER (PIO Enable Register) and PDR (PIO Disable Register). The register PSR (PIO Status Register) is the result of the set and clear registers and indicates whether the pin is controlled by the corresponding peripheral or by the PIO Controller. A value of 0 indicates that the pin is controlled by the corresponding on-chip peripheral selected in the ABSR (AB Select Status Register). A value of 1 indicates the pin is controlled by the PIO controller.

If a pin is used as a general purpose I/O line (not multiplexed with an on-chip peripheral), PER and PDR have no effect and PSR returns 1 for the corresponding bit.

After reset, most generally, the I/O lines are controlled by the PIO controller, i.e. PSR resets at 1. However, in some events, it is important that PIO lines are controlled by the peripheral (as in the case of memory chip select lines that must be driven inactive after reset or for address lines that must be driven low for booting out of an external memory). Thus, the reset value of PSR is defined at the product level, depending on the multiplexing of the device.

20.5.3 Peripheral A or B Selection

The PIO Controller provides multiplexing of up to two peripheral functions on a single pin. The selection is performed by writing ASR (A Select Register) and BSR (Select B Register). ABSR (AB Select Status Register) indicates which peripheral line is currently selected. For each pin, the corresponding bit at level 0 means peripheral A is selected whereas the corresponding bit at level 1 indicates that peripheral B is selected.

Note that multiplexing of peripheral lines A and B only affects the output line. The peripheral input lines are always connected to the pin input.

After reset, ABSR is 0, thus indicating that all the PIO lines are configured on peripheral A. However, peripheral A generally does not drive the pin as the PIO Controller resets in I/O line mode.

Writing in ASR and BSR manages ABSR regardless of the configuration of the pin. However, assignment of a pin to a peripheral function requires a write in the corresponding peripheral selection register (ASR or BSR) in addition to a write in PDR.

20.5.4 Output Control

When the I/O line is assigned to a peripheral function, i.e. the corresponding bit in PSR is at 0, the drive of the I/O line is controlled by the peripheral. Peripheral A or B, depending on the value in ABSR, determines whether the pin is driven or not.

When the I/O line is controlled by the PIO controller, the pin can be configured to be driven. This is done by writing OER (Output Enable Register) and ODR (Output Disable Register). The results of these write operations are detected in OSR (Output Status Register). When a bit in this

register is at 0, the corresponding I/O line is used as an input only. When the bit is at 1, the corresponding I/O line is driven by the PIO controller.

The level driven on an I/O line can be determined by writing in SODR (Set Output Data Register) and CODR (Clear Output Data Register). These write operations respectively set and clear ODSR (Output Data Status Register), which represents the data driven on the I/O lines. Writing in OER and ODR manages OSR whether the pin is configured to be controlled by the PIO controller or assigned to a peripheral function. This enables configuration of the I/O line prior to setting it to be managed by the PIO Controller.

Similarly, writing in SODR and CODR effects ODSR. This is important as it defines the first level driven on the I/O line.

20.5.5 Synchronous Data Output

Controlling all parallel busses using several PIOs requires two successive write operations in the SODR and CODR registers. This may lead to unexpected transient values. The PIO controller offers a direct control of PIO outputs by single write access to ODSR (Output Data Status Register). Only bits unmasked by OSWSR (Output Write Status Register) are written. The mask bits in the OWSR are set by writing to OWER (Output Write Enable Register) and cleared by writing to OWDR (Output Write Disable Register).

After reset, the synchronous data output is disabled on all the I/O lines as OWSR resets at 0x0.

20.5.6 Output Line Timings

Figure 20-4 shows how the outputs are driven either by writing SODR or CODR, or by directly writing ODSR. This last case is valid only if the corresponding bit in OWSR is set. Figure 20-4 also shows when the feedback in PDSR is available.

Figure 20-4. Output Line Timings

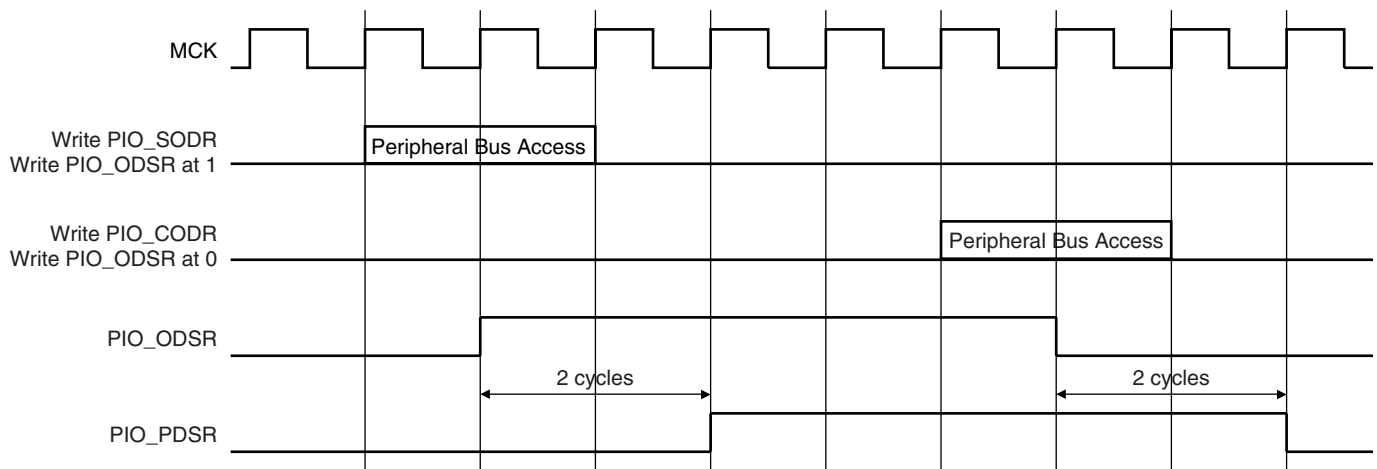

20.5.7 Inputs

The level on each I/O line can be read through PDSR (Pin Data Status Register). This register indicates the level of the I/O lines regardless of their configuration, whether uniquely as an input or driven by the PIO controller or driven by a peripheral.

Reading the I/O line levels requires the clock of the PIO controller to be enabled, otherwise PDSR reads the levels present on the I/O line at the time the clock was disabled.

20.5.8 Input Glitch Filtering

Optional input glitch filters are independently programmable on each I/O line. When the glitch filter is enabled, a glitch with a duration of less than 1/2 Master Clock (MCK) cycle is automatically rejected, while a pulse with a duration of 1 Master Clock cycle or more is accepted. For pulse durations between 1/2 Master Clock cycle and 1 Master Clock cycle the pulse may or may not be taken into account, depending on the precise timing of its occurrence. Thus for a pulse to be visible it must exceed 1 Master Clock cycle, whereas for a glitch to be reliably filtered out, its duration must not exceed 1/2 Master Clock cycle. The filter introduces one Master Clock cycle latency if the pin level change occurs before a rising edge. However, this latency does not appear if the pin level change occurs before a falling edge. This is illustrated in Figure 20-5.

The glitch filters are controlled by the register set; IFER (Input Filter Enable Register), IFDR (Input Filter Disable Register) and IFSR (Input Filter Status Register). Writing IFER and IFDR respectively sets and clears bits in IFSR. This last register enables the glitch filter on the I/O lines.

When the glitch filter is enabled, it does not modify the behavior of the inputs on the peripherals. It acts only on the value read in PDSR and on the input change interrupt detection. The glitch filters require that the PIO Controller clock is enabled.

Figure 20-5. Input Glitch Filter Timing

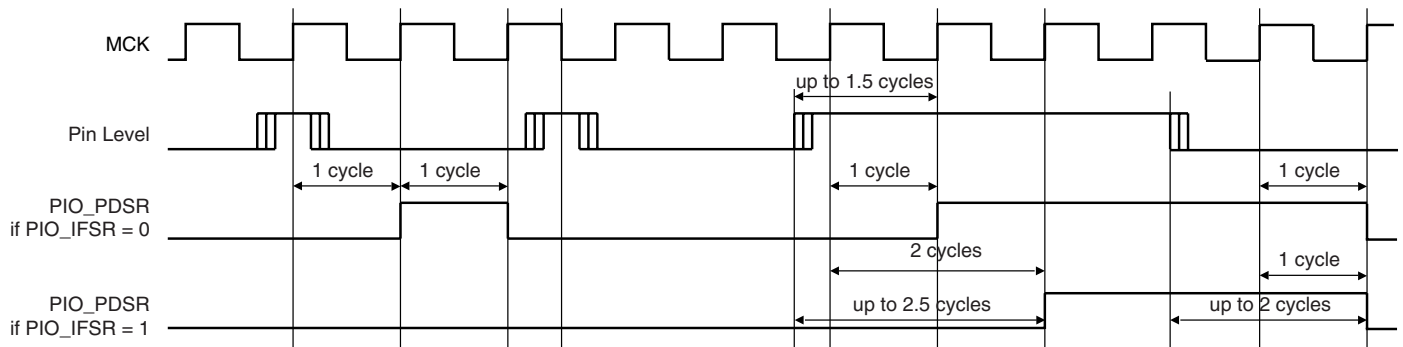

20.5.9 Input Change Interrupt

The PIO Controller can be programmed to generate an interrupt when it detects an input change on an I/O line. The Input Change Interrupt is controlled by writing IER (Interrupt Enable Register) and IDR (Interrupt Disable Register), which respectively enable and disable the input change interrupt by setting and clearing the corresponding bit in IMR (Interrupt Mask Register). As Input change detection is possible only by comparing two successive samplings of the input of the I/O line, the PIO Controller clock must be enabled. The Input Change Interrupt is available, regardless of the configuration of the I/O line, i.e. configured as an input only, controlled by the PIO Controller or assigned to a peripheral function.

When an input change is detected on an I/O line, the corresponding bit in ISR (Interrupt Status Register) is set. If the corresponding bit in IMR is set, the PIO Controller interrupt line is asserted. The interrupt signals of the thirty-two channels are ORed-wired together to generate a single interrupt signal to the Interrupt Controller.

When the software reads ISR, all the interrupts are automatically cleared. This signifies that all the interrupts that are pending when ISR is read must be handled.

Figure 20-6. Input Change Interrupt Timings

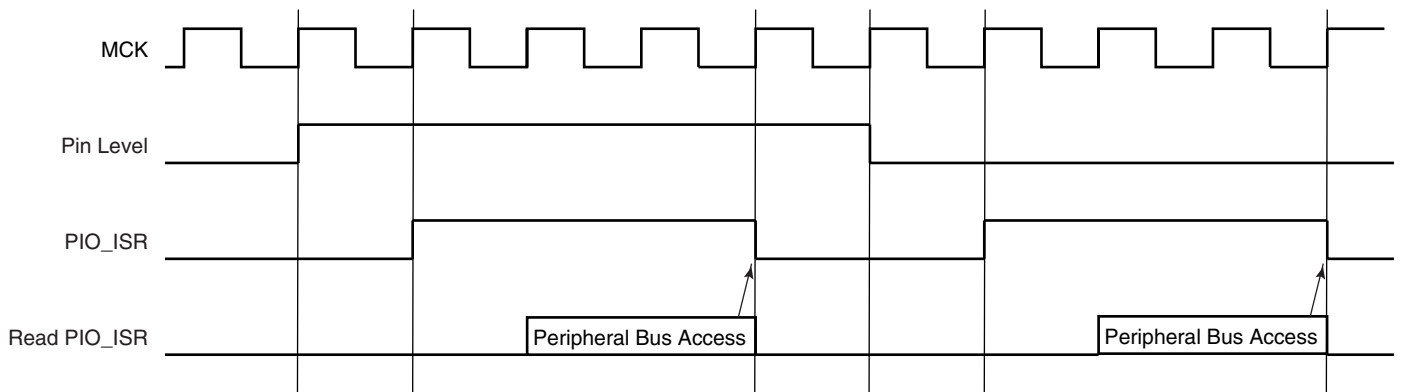

20.6 I/O Lines Programming Example

The programming example as shown in [Table 20-1](#) below is used to define the following configuration.

- 4-bit output port on I/O lines 0 to 3, (should be written in a single write operation)
- Four output signals on I/O lines 4 to 7 (to drive LEDs for example)
- Four input signals on I/O lines 8 to 11 (to read push-button states for example), with pull-up resistors, glitch filters and input change interrupts
- Four input signals on I/O line 12 to 15 to read an external device status (polled, thus no input change interrupt), no pull-up resistor, no glitch filter
- I/O lines 16 to 19 assigned to peripheral A functions with pull-up resistor
- I/O lines 20 to 23 assigned to peripheral B functions, no pull-up resistor
- I/O line 24 to 27 assigned to peripheral A with Input Change Interrupt and pull-up resistor

Table 20-1. Programming Example

Register	Value to be Written
PER	0x0000 FFFF
PDR	0x0FFF 0000
OER	0x0000 00FF
ODR	0x0FFF FF00
IFER	0x0000 0F00
IFDR	0x0FFF F0FF
SODR	0x0000 0000
CODR	0x0FFF FFFF
IER	0x0F00 0F00
IDR	0x00FF F0FF
PUDR	0x00F0 00F0
PUER	0x0F0F FF0F
ASR	0x0F0F 0000
BSR	0x00F0 0000
OWER	0x0000 000F
OWDR	0x0FFF FFF0

20.7 User Interface

Each I/O line controlled by the PIO Controller is associated with a bit in each of the PIO Controller User Interface registers. Each register is 32 bits wide. If a parallel I/O line is not defined, writing to the corresponding bits has no effect. Undefined bits read zero. If the I/O line is not multiplexed with any peripheral, the I/O line is controlled by the PIO Controller and PSR returns 1 systematically.

Table 20-2. Register Mapping

Offset	Register	Name	Access	Reset Value
0x0000	PIO Enable Register	PER	Write-only	–
0x0004	PIO Disable Register	PDR	Write-only	–
0x0008	PIO Status Register ⁽¹⁾	PSR	Read-only	0x0000 0000
0x000C	Reserved			
0x0010	Output Enable Register	OER	Write-only	–
0x0014	Output Disable Register	ODR	Write-only	–
0x0018	Output Status Register	OSR	Read-only	0x0000 0000
0x001C	Reserved			
0x0020	Glitch Input Filter Enable Register	IFER	Write-only	–
0x0024	Glitch Input Filter Disable Register	IFDR	Write-only	–
0x0028	Glitch Input Filter Status Register	IFSR	Read-only	0x0000 0000
0x002C	Reserved			
0x0030	Set Output Data Register	SODR	Write-only	–
0x0034	Clear Output Data Register	CODR	Write-only	–
0x0038	Output Data Status Register ⁽²⁾	ODSR	Read-only	0x0000 0000
0x003C	Pin Data Status Register ⁽³⁾	PDSR	Read-only	
0x0040	Interrupt Enable Register	IER	Write-only	–
0x0044	Interrupt Disable Register	IDR	Write-only	–
0x0048	Interrupt Mask Register	IMR	Read-only	0x0000 0000
0x004C	Interrupt Status Register ⁽⁴⁾	ISR	Read-only	0x0000 0000
0x0050	Multi-driver Enable Register	MDDR	Write-only	
0x0054	Multi-driver Disable Register	MDER	Write-only	
0x0058	Multi-driver Status Register	MDSR	Read-only	
0x005C	Reserved			
0x0060	Pull-up Disable Register	PUDR	Write-only	–
0x0064	Pull-up Enable Register	PUER	Write-only	–
0x0068	Pad Pull-up Status Register	PUSR	Read-only	0x0000 0000
0x006C	Reserved			

Table 20-2. Register Mapping (Continued)

Offset	Register	Name	Access	Reset Value
0x0070	Peripheral A Select Register ⁽⁵⁾	ASR	Write-only	–
0x0074	Peripheral B Select Register ⁽⁵⁾	BSR	Write-only	–
0x0078	AB Status Register ⁽⁵⁾	ABSR	Read-only	0x0000 0000
0x007C to 0x009C	Reserved			
0x00A0	Output Write Enable	OWER	Write-only	–
0x00A4	Output Write Disable	OWDR	Write-only	–
0x00A8	Output Write Status Register	OWSR	Read-only	0x0000 0000
0x00AC	Reserved			

- Notes:
1. Reset value of PSR depends on the product implementation.
 2. ODSR is Read-only or Read/Write depending on OWSR I/O lines.
 3. Reset value of PDSR depends on the level of the I/O lines.
 4. ISR is reset at 0x0. However, the first read of the register may read a different value as input changes may have occurred.
 5. Only this set of registers clears the status by writing 1 in the first register and sets the status by writing 1 in the second register.

20.7.1 PIO Controller PIO Enable Register

Name: PER

Access Type: Write-only

31	30	29	28	27	26	25	24
P31	P30	P29	P28	P27	P26	P25	P24
23	22	21	20	19	18	17	16
P23	P22	P21	P20	P19	P18	P17	P16
15	14	13	12	11	10	9	8
P15	P14	P13	P12	P11	P10	P9	P8
7	6	5	4	3	2	1	0
P7	P6	P5	P4	P3	P2	P1	P0

- **P0-P31: PIO Enable**

0 = No effect.

1 = Enables the PIO to control the corresponding pin (disables peripheral control of the pin).

20.7.2 PIO Controller PIO Disable Register

Name: PDR

Access Type: Write-only

31	30	29	28	27	26	25	24
P31	P30	P29	P28	P27	P26	P25	P24
23	22	21	20	19	18	17	16
P23	P22	P21	P20	P19	P18	P17	P16
15	14	13	12	11	10	9	8
P15	P14	P13	P12	P11	P10	P9	P8
7	6	5	4	3	2	1	0
P7	P6	P5	P4	P3	P2	P1	P0

- **P0-P31: PIO Disable**

0 = No effect.

1 = Disables the PIO from controlling the corresponding pin (enables peripheral control of the pin).

20.7.3 PIO Controller PIO Status Register

Name: PSR

Access Type: Read-only

31	30	29	28	27	26	25	24
P31	P30	P29	P28	P27	P26	P25	P24
23	22	21	20	19	18	17	16
P23	P22	P21	P20	P19	P18	P17	P16
15	14	13	12	11	10	9	8
P15	P14	P13	P12	P11	P10	P9	P8
7	6	5	4	3	2	1	0
P7	P6	P5	P4	P3	P2	P1	P0

- **P0-P31: PIO Status**

0 = PIO is inactive on the corresponding I/O line (peripheral is active).

1 = PIO is active on the corresponding I/O line (peripheral is inactive).

20.7.4 PIO Controller Output Enable Register

Name: OER

Access Type: Write-only

31	30	29	28	27	26	25	24
P31	P30	P29	P28	P27	P26	P25	P24
23	22	21	20	19	18	17	16
P23	P22	P21	P20	P19	P18	P17	P16
15	14	13	12	11	10	9	8
P15	P14	P13	P12	P11	P10	P9	P8
7	6	5	4	3	2	1	0
P7	P6	P5	P4	P3	P2	P1	P0

• **P0-P31: Output Enable**

0 = No effect.

1 = Enables the output on the I/O line.

20.7.5 PIO Controller Output Disable Register

Name: ODR

Access Type: Write-only

31	30	29	28	27	26	25	24
P31	P30	P29	P28	P27	P26	P25	P24
23	22	21	20	19	18	17	16
P23	P22	P21	P20	P19	P18	P17	P16
15	14	13	12	11	10	9	8
P15	P14	P13	P12	P11	P10	P9	P8
7	6	5	4	3	2	1	0
P7	P6	P5	P4	P3	P2	P1	P0

- **P0-P31: Output Disable**

0 = No effect.

1 = Disables the output on the I/O line.

20.7.6 PIO Controller Output Status Register

Name: OSR

Access Type: Read-only

31	30	29	28	27	26	25	24
P31	P30	P29	P28	P27	P26	P25	P24
23	22	21	20	19	18	17	16
P23	P22	P21	P20	P19	P18	P17	P16
15	14	13	12	11	10	9	8
P15	P14	P13	P12	P11	P10	P9	P8
7	6	5	4	3	2	1	0
P7	P6	P5	P4	P3	P2	P1	P0

- **P0-P31: Output Status**

0 = The I/O line is a pure input.

1 = The I/O line is enabled in output.

20.7.7 PIO Controller Glitch Input Filter Enable Register

Name: IFER

Access Type: Write-only

31	30	29	28	27	26	25	24
P31	P30	P29	P28	P27	P26	P25	P24
23	22	21	20	19	18	17	16
P23	P22	P21	P20	P19	P18	P17	P16
15	14	13	12	11	10	9	8
P15	P14	P13	P12	P11	P10	P9	P8
7	6	5	4	3	2	1	0
P7	P6	P5	P4	P3	P2	P1	P0

- **P0-P31: Input Filter Enable**

0 = No effect.

1 = Enables the input glitch filter on the I/O line.

20.7.8 PIO Controller Glitch Input Filter Disable Register

Name: IFDR

Access Type: Write-only

31	30	29	28	27	26	25	24
P31	P30	P29	P28	P27	P26	P25	P24
23	22	21	20	19	18	17	16
P23	P22	P21	P20	P19	P18	P17	P16
15	14	13	12	11	10	9	8
P15	P14	P13	P12	P11	P10	P9	P8
7	6	5	4	3	2	1	0
P7	P6	P5	P4	P3	P2	P1	P0

- **P0-P31: Input Filter Disable**

0 = No effect.

1 = Disables the input glitch filter on the I/O line.

20.7.9 PIO Controller Glitch Input Filter Status Register

Name: IFSR

Access Type: Read-only

31	30	29	28	27	26	25	24
P31	P30	P29	P28	P27	P26	P25	P24
23	22	21	20	19	18	17	16
P23	P22	P21	P20	P19	P18	P17	P16
15	14	13	12	11	10	9	8
P15	P14	P13	P12	P11	P10	P9	P8
7	6	5	4	3	2	1	0
P7	P6	P5	P4	P3	P2	P1	P0

- **P0-P31: Input Filer Status**

0 = The input glitch filter is disabled on the I/O line.

1 = The input glitch filter is enabled on the I/O line.

20.7.10 PIO Controller Set Output Data Register

Name: SODR

Access Type: Write-only

31	30	29	28	27	26	25	24
P31	P30	P29	P28	P27	P26	P25	P24
23	22	21	20	19	18	17	16
P23	P22	P21	P20	P19	P18	P17	P16
15	14	13	12	11	10	9	8
P15	P14	P13	P12	P11	P10	P9	P8
7	6	5	4	3	2	1	0
P7	P6	P5	P4	P3	P2	P1	P0

• **P0-P31: Set Output Data**

0 = No effect.

1 = Sets the data to be driven on the I/O line.

20.7.11 PIO Controller Clear Output Data Register

Name: CODR

Access Type: Write-only

31	30	29	28	27	26	25	24
P31	P30	P29	P28	P27	P26	P25	P24
23	22	21	20	19	18	17	16
P23	P22	P21	P20	P19	P18	P17	P16
15	14	13	12	11	10	9	8
P15	P14	P13	P12	P11	P10	P9	P8
7	6	5	4	3	2	1	0
P7	P6	P5	P4	P3	P2	P1	P0

- **P0-P31: Set Output Data**

0 = No effect.

1 = Clears the data to be driven on the I/O line.

20.7.12 PIO Controller Output Data Status Register

Name: ODSR

Access Type: Read-only or Read/Write

31	30	29	28	27	26	25	24
P31	P30	P29	P28	P27	P26	P25	P24
23	22	21	20	19	18	17	16
P23	P22	P21	P20	P19	P18	P17	P16
15	14	13	12	11	10	9	8
P15	P14	P13	P12	P11	P10	P9	P8
7	6	5	4	3	2	1	0
P7	P6	P5	P4	P3	P2	P1	P0

- **P0-P31: Output Data Status**

0 = The data to be driven on the I/O line is 0.

1 = The data to be driven on the I/O line is 1.

20.7.13 PIO Controller Pin Data Status Register

Name: PDSR

Access Type: Read-only

31	30	29	28	27	26	25	24
P31	P30	P29	P28	P27	P26	P25	P24
23	22	21	20	19	18	17	16
P23	P22	P21	P20	P19	P18	P17	P16
15	14	13	12	11	10	9	8
P15	P14	P13	P12	P11	P10	P9	P8
7	6	5	4	3	2	1	0
P7	P6	P5	P4	P3	P2	P1	P0

- **P0-P31: Output Data Status**

0 = The I/O line is at level 0.

1 = The I/O line is at level 1.

20.7.14 PIO Controller Interrupt Enable Register

Name: IER

Access Type: Write-only

31	30	29	28	27	26	25	24
P31	P30	P29	P28	P27	P26	P25	P24
23	22	21	20	19	18	17	16
P23	P22	P21	P20	P19	P18	P17	P16
15	14	13	12	11	10	9	8
P15	P14	P13	P12	P11	P10	P9	P8
7	6	5	4	3	2	1	0
P7	P6	P5	P4	P3	P2	P1	P0

• **P0-P31: Input Change Interrupt Enable**

0 = No effect.

1 = Enables the Input Change Interrupt on the I/O line.

20.7.15 PIO Controller Interrupt Disable Register

Name: IDR

Access Type: Write-only

31	30	29	28	27	26	25	24
P31	P30	P29	P28	P27	P26	P25	P24
23	22	21	20	19	18	17	16
P23	P22	P21	P20	P19	P18	P17	P16
15	14	13	12	11	10	9	8
P15	P14	P13	P12	P11	P10	P9	P8
7	6	5	4	3	2	1	0
P7	P6	P5	P4	P3	P2	P1	P0

- **P0-P31: Input Change Interrupt Disable**

0 = No effect.

1 = Disables the Input Change Interrupt on the I/O line.

20.7.16 PIO Controller Interrupt Mask Register

Name: IMR

Access Type: Read-only

31	30	29	28	27	26	25	24
P31	P30	P29	P28	P27	P26	P25	P24
23	22	21	20	19	18	17	16
P23	P22	P21	P20	P19	P18	P17	P16
15	14	13	12	11	10	9	8
P15	P14	P13	P12	P11	P10	P9	P8
7	6	5	4	3	2	1	0
P7	P6	P5	P4	P3	P2	P1	P0

- **P0-P31: Input Change Interrupt Mask**

0 = Input Change Interrupt is disabled on the I/O line.

1 = Input Change Interrupt is enabled on the I/O line.

20.7.17 PIO Controller Interrupt Status Register

Name: ISR

Access Type: Read-only

31	30	29	28	27	26	25	24
P31	P30	P29	P28	P27	P26	P25	P24
23	22	21	20	19	18	17	16
P23	P22	P21	P20	P19	P18	P17	P16
15	14	13	12	11	10	9	8
P15	P14	P13	P12	P11	P10	P9	P8
7	6	5	4	3	2	1	0
P7	P6	P5	P4	P3	P2	P1	P0

- **P0-P31: Input Change Interrupt Status**

0 = No Input Change has been detected on the I/O line since ISR was last read or since reset.

1 = At least one Input Change has been detected on the I/O line since ISR was last read or since reset.

20.7.18 PIO Controller Multi-driver Enable Register

Name: MDER

Access Type: Write-only

31	30	29	28	27	26	25	24
P31	P30	P29	P28	P27	P26	P25	P24
23	22	21	20	19	18	17	16
P23	P22	P21	P20	P19	P18	P17	P16
15	14	13	12	11	10	9	8
P15	P14	P13	P12	P11	P10	P9	P8
7	6	5	4	3	2	1	0
P7	P6	P5	P4	P3	P2	P1	P0

This register is used to enable PIO output drivers to be configured as open drain to support external drivers on the same pin.

- **P0-P31:**

0 = No effect.

1 = Enables multi-drive option on the corresponding pin.

20.7.19 PIO Controller Multi-driver Disable Register

Name: MDDR

Access Type: Write-only

31	30	29	28	27	26	25	24
P31	P30	P29	P28	P27	P26	P25	P24
23	22	21	20	19	18	17	16
P23	P22	P21	P20	P19	P18	P17	P16
15	14	13	12	11	10	9	8
P15	P14	P13	P12	P11	P10	P9	P8
7	6	5	4	3	2	1	0
P7	P6	P5	P4	P3	P2	P1	P0

This register is used to diaspble the open drain configuration of the output buffer.

- **P0-P31:**

0 = No effect.

1 = Disables multi-drive option on the corresponding pin.

20.7.20 PIO Controller Multi-driver Status Register

Name: MDSR

Access Type: Read-only

31	30	29	28	27	26	25	24
P31	P30	P29	P28	P27	P26	P25	P24
23	22	21	20	19	18	17	16
P23	P22	P21	P20	P19	P18	P17	P16
15	14	13	12	11	10	9	8
P15	P14	P13	P12	P11	P10	P9	P8
7	6	5	4	3	2	1	0
P7	P6	P5	P4	P3	P2	P1	P0

This register indicates which pins are configured with open drain drivers.

- **P0-P31:**

0 = PIO is not configured as an open drain.

1 = PIO is configured as an open drain.

20.7.21 PIO Pull Up Disable Register

Name: PUDR

Access Type: Write-only

31	30	29	28	27	26	25	24
P31	P30	P29	P28	P27	P26	P25	P24
23	22	21	20	19	18	17	16
P23	P22	P21	P20	P19	P18	P17	P16
15	14	13	12	11	10	9	8
P15	P14	P13	P12	P11	P10	P9	P8
7	6	5	4	3	2	1	0
P7	P6	P5	P4	P3	P2	P1	P0

- **P0-P31: Pull Up Disable.**

0 = No effect.

1 = Disables the pull up resistor on the I/O line.

20.7.22 PIO Pull Up Enable Register

Name: PUER

Access Type: Write-only

31	30	29	28	27	26	25	24
P31	P30	P29	P28	P27	P26	P25	P24
23	22	21	20	19	18	17	16
P23	P22	P21	P20	P19	P18	P17	P16
15	14	13	12	11	10	9	8
P15	P14	P13	P12	P11	P10	P9	P8
7	6	5	4	3	2	1	0
P7	P6	P5	P4	P3	P2	P1	P0

• **P0-P31: Pull Up Enable.**

0 = No effect.

1 = Enables the pull up resistor on the I/O line.

20.7.23 PIO Pull Up Status Register

Name: PUSR

Access Type: Read-only

31	30	29	28	27	26	25	24
P31	P30	P29	P28	P27	P26	P25	P24
23	22	21	20	19	18	17	16
P23	P22	P21	P20	P19	P18	P17	P16
15	14	13	12	11	10	9	8
P15	P14	P13	P12	P11	P10	P9	P8
7	6	5	4	3	2	1	0
P7	P6	P5	P4	P3	P2	P1	P0

- **P0-P31: Pull Up Status.**

0 = Pull Up resistor is enabled on the I/O line.

1 = Pull Up resistor is disabled on the I/O line.

20.7.24 PIO Peripheral A Select Register

Name: ASR

Access Type: Write-only

31	30	29	28	27	26	25	24
P31	P30	P29	P28	P27	P26	P25	P24
23	22	21	20	19	18	17	16
P23	P22	P21	P20	P19	P18	P17	P16
15	14	13	12	11	10	9	8
P15	P14	P13	P12	P11	P10	P9	P8
7	6	5	4	3	2	1	0
P7	P6	P5	P4	P3	P2	P1	P0

• **P0-P31: Peripheral A Select.**

0 = No effect.

1 = Assigns the I/O line to the Peripheral A function.

20.7.25 PIO Peripheral B Select Register

Name: BSR

Access Type: Write-only

31	30	29	28	27	26	25	24
P31	P30	P29	P28	P27	P26	P25	P24
23	22	21	20	19	18	17	16
P23	P22	P21	P20	P19	P18	P17	P16
15	14	13	12	11	10	9	8
P15	P14	P13	P12	P11	P10	P9	P8
7	6	5	4	3	2	1	0
P7	P6	P5	P4	P3	P2	P1	P0

- **P0-P31: Peripheral B Select.**

0 = No effect.

1 = Assigns the I/O line to the peripheral B function.

20.7.26 PIO Peripheral A B Status Register

Name: ABSR

Access Type: Read-only

31	30	29	28	27	26	25	24
P31	P30	P29	P28	P27	P26	P25	P24
23	22	21	20	19	18	17	16
P23	P22	P21	P20	P19	P18	P17	P16
15	14	13	12	11	10	9	8
P15	P14	P13	P12	P11	P10	P9	P8
7	6	5	4	3	2	1	0
P7	P6	P5	P4	P3	P2	P1	P0

• **P0-P31: Peripheral A B Status.**

0 = The I/O line is assigned to the Peripheral A.

1 = The I/O line is assigned to the Peripheral B.

20.7.27 PIO Output Write Enable Register

Name: OWER

Access Type: Write-only

31	30	29	28	27	26	25	24
P31	P30	P29	P28	P27	P26	P25	P24
23	22	21	20	19	18	17	16
P23	P22	P21	P20	P19	P18	P17	P16
15	14	13	12	11	10	9	8
P15	P14	P13	P12	P11	P10	P9	P8
7	6	5	4	3	2	1	0
P7	P6	P5	P4	P3	P2	P1	P0

- **P0-P31: Output Write Enable.**

0 = No effect.

1 = Enables writing ODSR for the I/O line.

20.7.28 PIO Output Write Disable Register

Name: OWDR

Access Type: Write-only

31	30	29	28	27	26	25	24
P31	P30	P29	P28	P27	P26	P25	P24
23	22	21	20	19	18	17	16
P23	P22	P21	P20	P19	P18	P17	P16
15	14	13	12	11	10	9	8
P15	P14	P13	P12	P11	P10	P9	P8
7	6	5	4	3	2	1	0
P7	P6	P5	P4	P3	P2	P1	P0

- **P0-P31: Output Write Disable.**

0 = No effect.

1 = Disables writing ODSR for the I/O line.

20.7.29 PIO Output Write Status Register

Name: OWSR

Access Type: Read-only

31	30	29	28	27	26	25	24
P31	P30	P29	P28	P27	P26	P25	P24
23	22	21	20	19	18	17	16
P23	P22	P21	P20	P19	P18	P17	P16
15	14	13	12	11	10	9	8
P15	P14	P13	P12	P11	P10	P9	P8
7	6	5	4	3	2	1	0
P7	P6	P5	P4	P3	P2	P1	P0

• **P0-P31: Output Write Status.**

0 = Writing ODSR does not affect the I/O line.

1 = Writing ODSR affects the I/O line.

21. Serial Peripheral Interface (SPI)

Rev: 1.7.1.0

21.1 Features

- **Supports Communication with Serial External Devices**
 - Four Chip Selects with External Decoder Support Allow Communication with Up to 15 Peripherals
 - Serial Memories, such as DataFlash and 3-wire EEPROMs
 - Serial Peripherals, such as ADCs, DACs, LCD Controllers, CAN Controllers and Sensors
 - External Co-processors
- **Master or Slave Serial Peripheral Bus Interface**
 - 8- to 16-bit Programmable Data Length Per Chip Select
 - Programmable Phase and Polarity Per Chip Select
 - Programmable Transfer Delays Between Consecutive Transfers and Between Clock and Data Per Chip Select
 - Programmable Delay Between Consecutive Transfers
 - Selectable Mode Fault Detection
- **Connection to PDC Channel Capabilities Optimizes Data Transfers**
 - One Channel for the Receiver, One Channel for the Transmitter
 - Next Buffer Support

21.2 Description

The Serial Peripheral Interface (SPI) circuit is a synchronous serial data link that provides communication with external devices in Master or Slave Mode. It also enables communication between processors if an external processor is connected to the system.

The Serial Peripheral Interface is essentially a shift register that serially transmits data bits to other SPIs. During a data transfer, one SPI system acts as the “master” which controls the data flow, while the other devices act as “slaves” which have data shifted into and out by the master. Different CPUs can take turn being masters (Multiple Master Protocol opposite to Single Master Protocol where one CPU is always the master while all of the others are always slaves) and one master may simultaneously shift data into multiple slaves. However, only one slave may drive its output to write data back to the master at any given time.

A slave device is selected when the master asserts its NSS signal. If multiple slave devices exist, the master generates a separate slave select signal for each slave (NPCS).

The SPI system consists of two data lines and two control lines:

- **Master Out Slave In (MOSI):** This data line supplies the output data from the master shifted into the input(s) of the slave(s).
- **Master In Slave Out (MISO):** This data line supplies the output data from a slave to the input of the master. There may be no more than one slave transmitting data during any particular transfer.
- **Serial Clock (SPCK):** This control line is driven by the master and regulates the flow of the data bits. The master may transmit data at a variety of baud rates; the SPCK line cycles once for each bit that is transmitted.
- **Slave Select (NSS):** This control line allows slaves to be turned on and off by hardware.

21.3 Block Diagram

Figure 21-1. Block Diagram

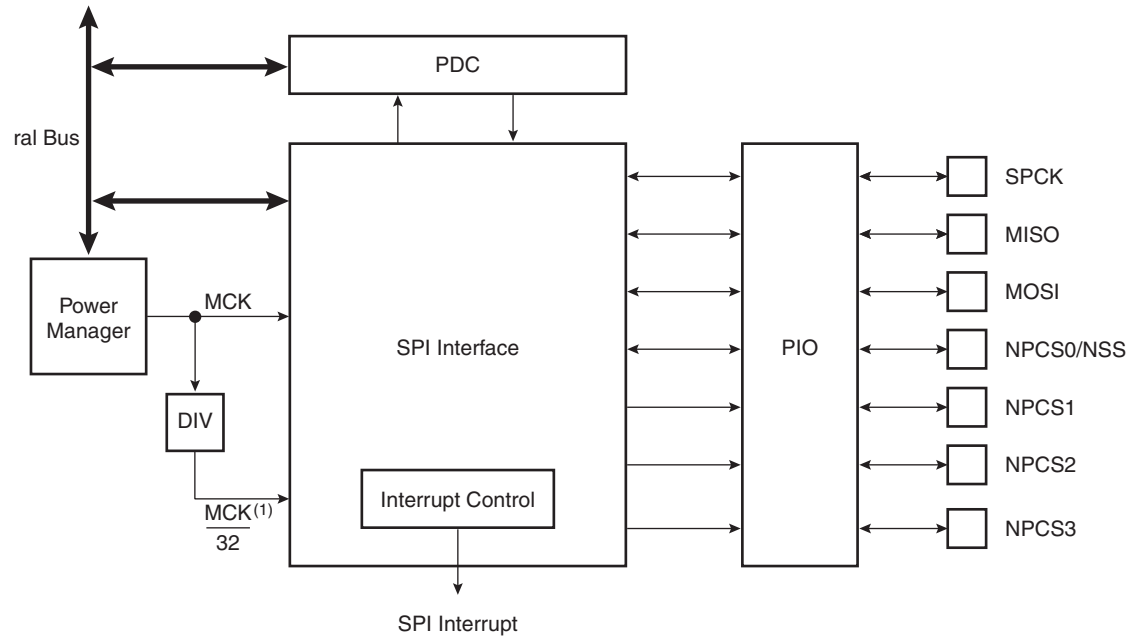

21.4 Application Block Diagram

Figure 21-2. Application Block Diagram: Single Master/Multiple Slave Implementation

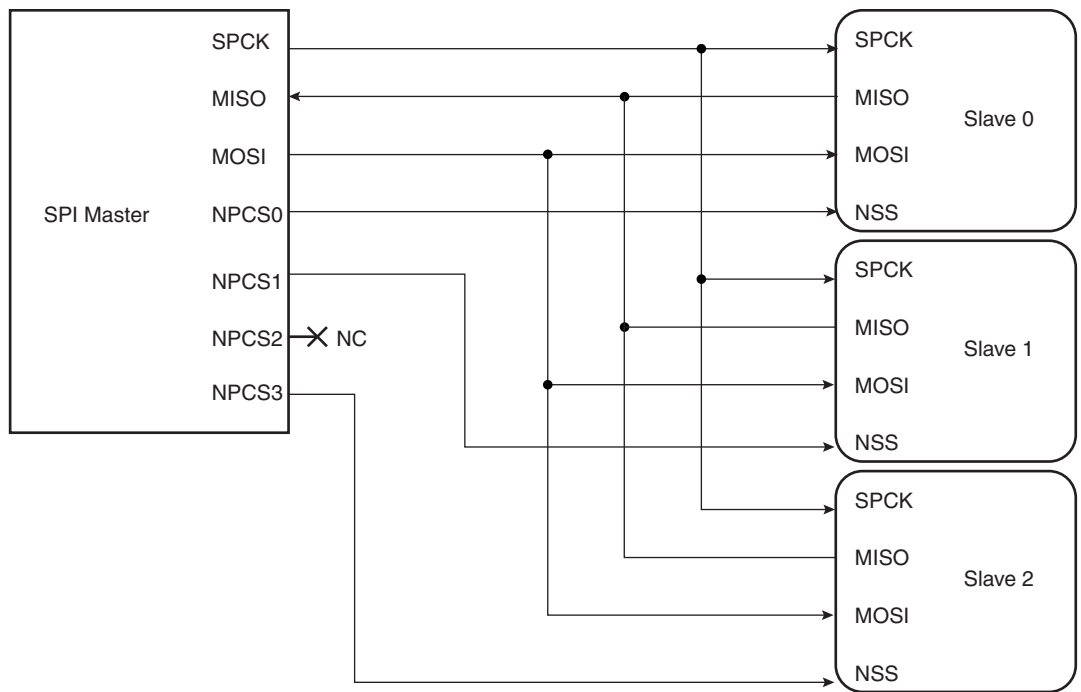

21.5 Signal Description

Table 21-1. Signal Description

Pin Name	Pin Description	Type	
		Master	Slave
MISO	Master In Slave Out	Input	Output
MOSI	Master Out Slave In	Output	Input
SPCK	Serial Clock	Output	Input
NPCS1-NPCS3	Peripheral Chip Selects	Output	Unused
NPCS0/NSS	Peripheral Chip Select/Slave Select	Output	Input

21.6 Product Dependencies

21.6.1 I/O Lines

The pins used for interfacing the compliant external devices may be multiplexed with PIO lines. The programmer must first program the PIO controllers to assign the SPI pins to their peripheral functions.

21.6.2 Power Management

The SPI clock is generated by the Power Manager. Before using the SPI, the programmer must ensure that the SPI clock is enabled in the Power Manager.

In the SPI description, Master Clock (MCK) is the clock of the peripheral bus to which the SPI is connected.

21.6.3 Interrupt

The SPI interface has an interrupt line connected to the Interrupt Controller. Handling the SPI interrupt requires programming the interrupt controller before configuring the SPI.

21.7 Functional Description

21.7.1 Modes of Operation

The SPI operates in Master Mode or in Slave Mode.

Operation in Master Mode is programmed by writing at 1 the MSTR bit in the Mode Register. The pins NPCS0 to NPCS3 are all configured as outputs, the SPCK pin is driven, the MISO line is wired on the receiver input and the MOSI line driven as an output by the transmitter.

If the MSTR bit is written at 0, the SPI operates in Slave Mode. The MISO line is driven by the transmitter output, the MOSI line is wired on the receiver input, the SPCK pin is driven by the transmitter to synchronize the receiver. The NPCS0 pin becomes an input, and is used as a Slave Select signal (NSS). The pins NPCS1 to NPCS3 are not driven and can be used for other purposes.

The data transfers are identically programmable for both modes of operations. The baud rate generator is activated only in Master Mode.

21.7.2 Data Transfer

Four combinations of polarity and phase are available for data transfers. The clock polarity is programmed with the CPOL bit in the Chip Select Register. The clock phase is programmed with the NCPHA bit. These two parameters determine the edges of the clock signal on which data is driven and sampled. Each of the two parameters has two possible states, resulting in four possible combinations that are incompatible with one another. Thus, a master/slave pair must use the same parameter pair values to communicate. If multiple slaves are used and fixed in different configurations, the master must reconfigure itself each time it needs to communicate with a different slave.

Table 21-2 shows the four modes and corresponding parameter settings.

Table 21-2. SPI Bus Protocol Mode

SPI Mode	CPOL	NCPHA
0	0	1
1	0	0
2	1	1
3	1	0

Figure 21-3 and Figure 21-4 show examples of data transfers.

Figure 21-3. SPI Transfer Format (NCPHA = 1, 8 bits per transfer)

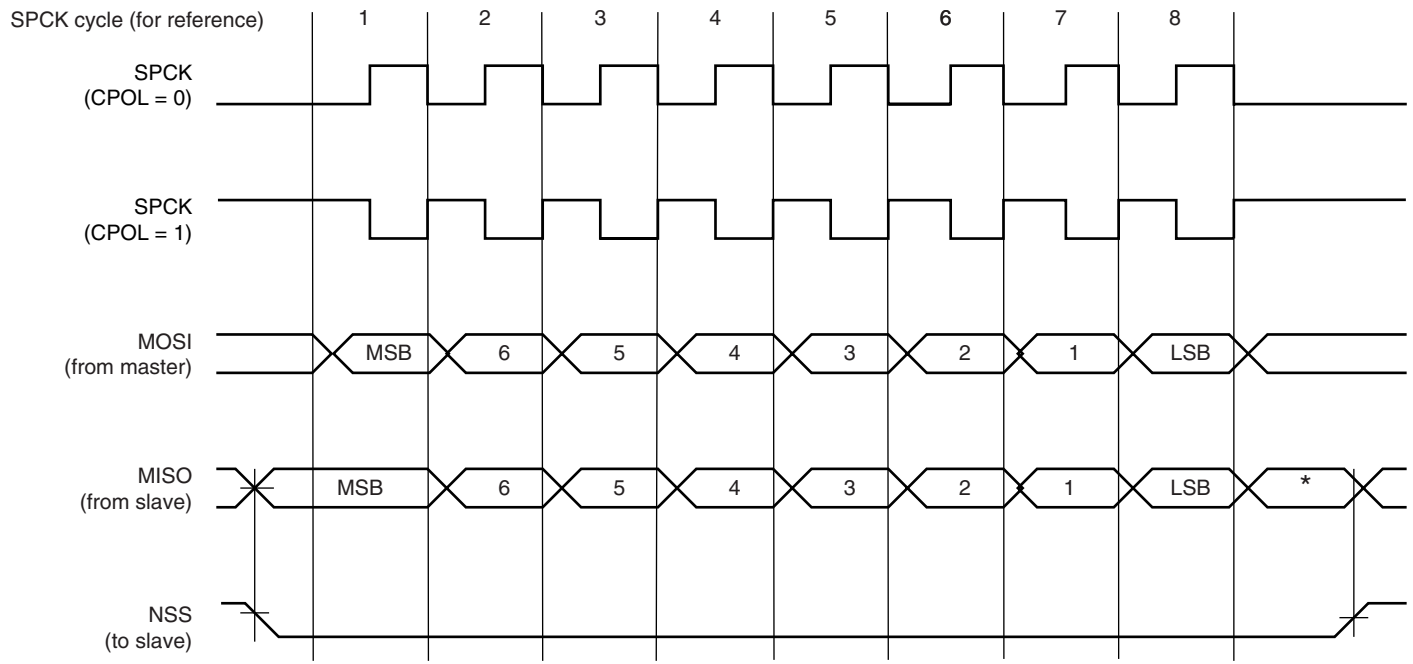

* Not defined, but normally MSB of previous character received.

Figure 21-4. SPI Transfer Format (NCPHA = 0, 8 bits per transfer)

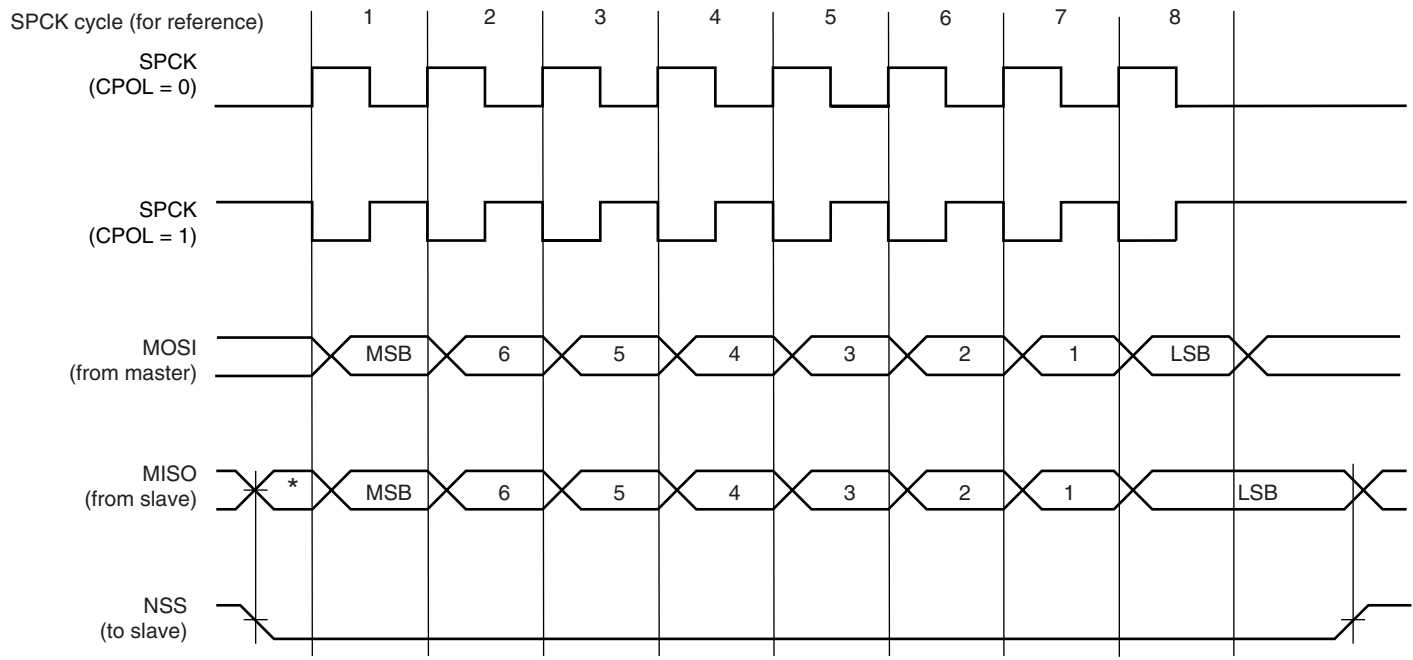

* Not defined but normally LSB of previous character transmitted.

21.7.3 Master Mode Operations

When configured in Master Mode, the SPI uses the internal programmable baud rate generator as clock source. It fully controls the data transfers to and from the slave(s) connected to the SPI bus. The SPI drives the chip select line to the slave and the serial clock signal (SPCK).

The SPI features two holding registers, the Transmit Data Register and the Receive Data Register, and a single Shift Register. The holding registers maintain the data flow at a constant rate.

After enabling the SPI, a data transfer begins when the processor writes to the TDR (Transmit Data Register). The written data is immediately transferred in the Shift Register and transfer on the SPI bus starts. While the data in the Shift Register is shifted on the MOSI line, the MISO line is sampled and shifted in the Shift Register. Transmission cannot occur without reception.

Before writing the TDR, the PCS field must be set in order to select a slave.

If new data is written in TDR during the transfer, it stays in it until the current transfer is completed. Then, the received data is transferred from the Shift Register to RDR, the data in TDR is loaded in the Shift Register and a new transfer starts.

The transfer of a data written in TDR in the Shift Register is indicated by the TDRE bit (Transmit Data Register Empty) in the Status Register (SR). When new data is written in TDR, this bit is cleared. The TDRE bit is used to trigger the Transmit PDC channel.

The end of transfer is indicated by the TXEMPTY flag in the SR register. If a transfer delay (DLY-BCT) is greater than 0 for the last transfer, TXEMPTY is set after the completion of said delay. The master clock (MCK) can be switched off at this time.

The transfer of received data from the Shift Register in RDR is indicated by the RDRF bit (Receive Data Register Full) in the Status Register (SR). When the received data is read, the RDRF bit is cleared.

If the RDR (Receive Data Register) has not been read before new data is received, the Overrun Error bit (OVRES) in SR is set. As long as this flag is set, data is loaded in RDR. The user has to read the status register to clear the OVRES bit.

[Figure 21-5 on page 288](#) shows a block diagram of the SPI when operating in Master Mode. [Figure 21-6 on page 289](#) shows a flow chart describing how transfers are handled.

21.7.3.1 Master Mode Block Diagram

Figure 21-5. Master Mode Block Diagram

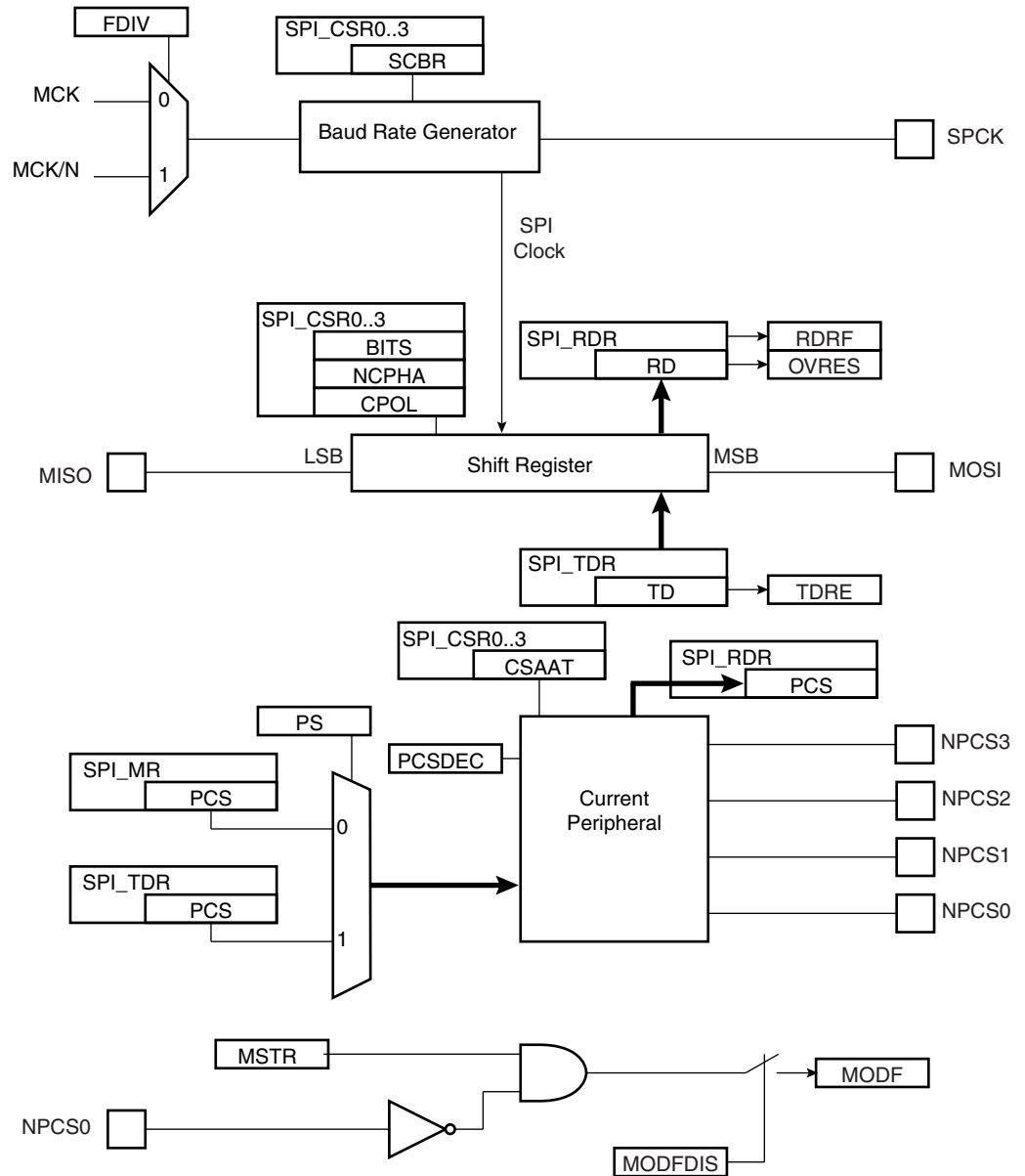

21.7.3.2 Master Mode Flow Diagram

Figure 21-6. Master Mode Flow Diagram S

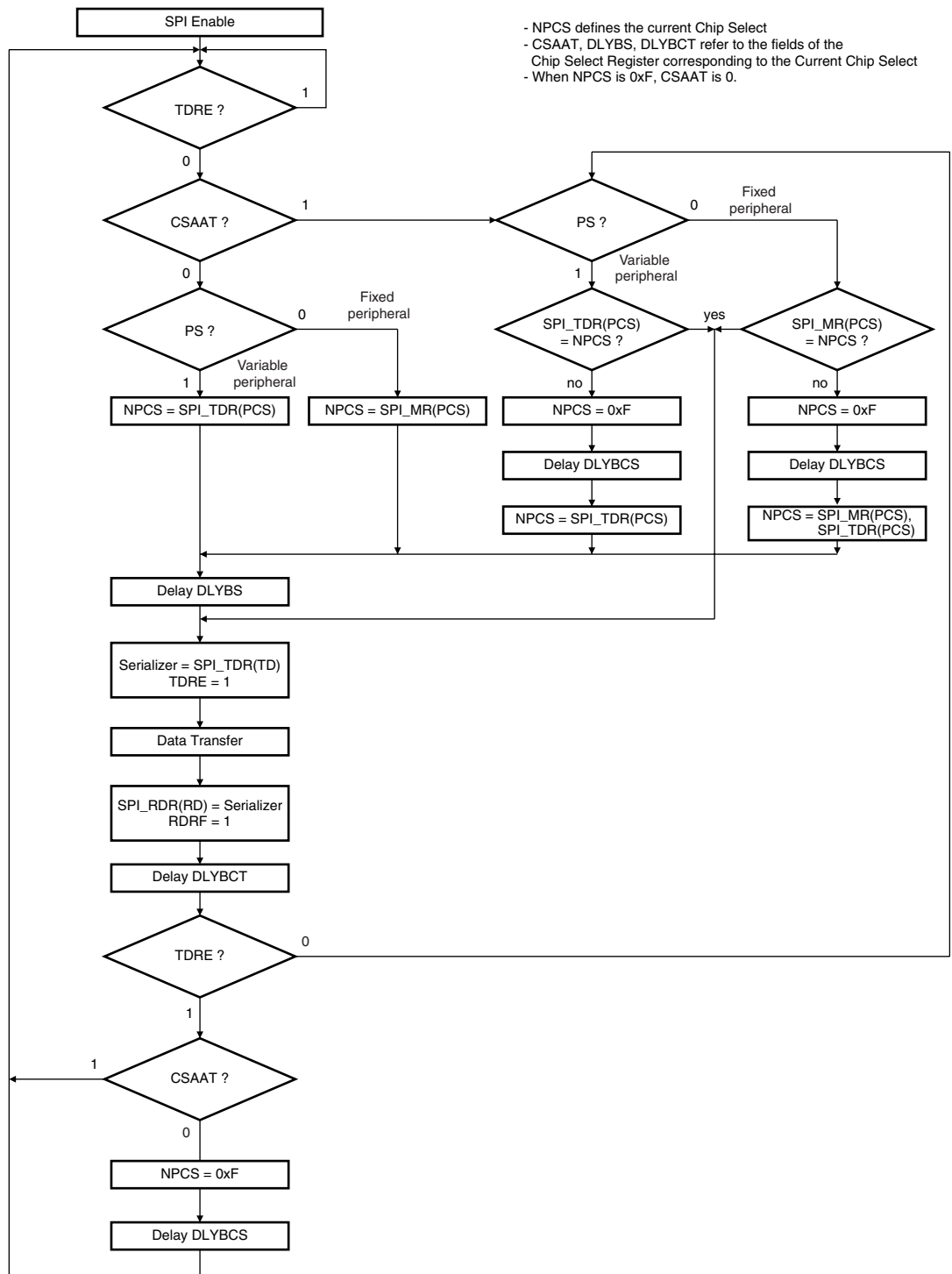

21.7.3.3 Clock Generation

The SPI Baud rate clock is generated by dividing the Master Clock (MCK) or the Master Clock divided by 32, by a value between 1 and 255. The selection between Master Clock or Master Clock divided by 32 is done by the FDIV value set in the Mode Register

This allows a maximum operating baud rate at up to Master Clock and a minimum operating baud rate of MCK divided by 255*32.

Programming the SCBR field at 0 is forbidden. Triggering a transfer while SCBR is at 0 can lead to unpredictable results.

At reset, SCBR is 0 and the user has to program it at a valid value before performing the first transfer.

The divisor can be defined independently for each chip select, as it has to be programmed in the SCBR field of the Chip Select Registers. This allows the SPI to automatically adapt the baud rate for each interfaced peripheral without reprogramming.

21.7.3.4 Transfer Delays

Figure 21-7 shows a chip select transfer change and consecutive transfers on the same chip select. Three delays can be programmed to modify the transfer waveforms:

- The delay between chip selects, programmable only once for all the chip selects by writing the DLYBCS field in the Mode Register. Allows insertion of a delay between release of one chip select and before assertion of a new one.
- The delay before SPCK, independently programmable for each chip select by writing the field DLYBS. Allows the start of SPCK to be delayed after the chip select has been asserted.
- The delay between consecutive transfers, independently programmable for each chip select by writing the DLYBCT field. Allows insertion of a delay between two transfers occurring on the same chip select

These delays allow the SPI to be adapted to the interfaced peripherals and their speed and bus release time.

Figure 21-7. Programmable Delays

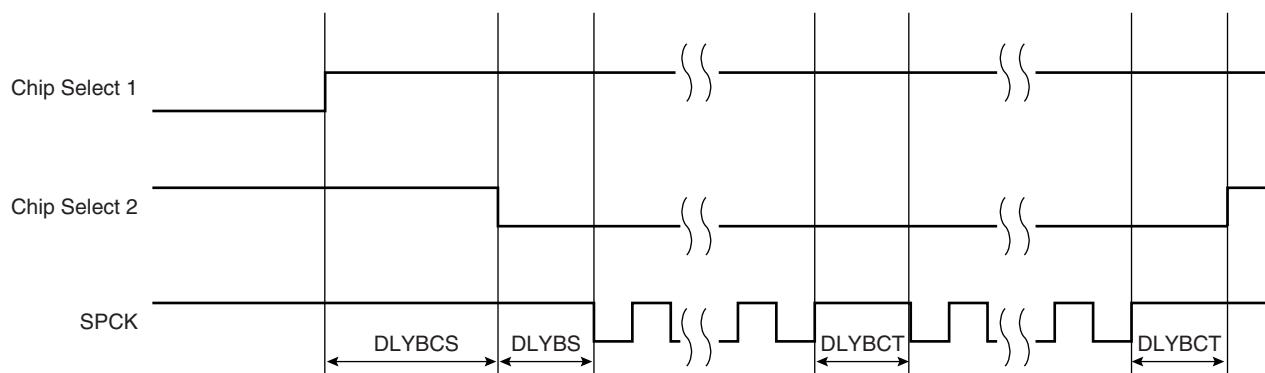

21.7.3.5 Peripheral Selection

The serial peripherals are selected through the assertion of the NPCS0 to NPCS3 signals. By default, all the NPCS signals are high before and after each transfer.

The peripheral selection can be performed in two different ways:

- Fixed Peripheral Select: SPI exchanges data with only one peripheral
- Variable Peripheral Select: Data can be exchanged with more than one peripheral

Fixed Peripheral Select is activated by writing the PS bit to zero in MR (Mode Register). In this case, the current peripheral is defined by the PCS field in MR and the PCS field in TDR have no effect.

Variable Peripheral Select is activated by setting PS bit to one. The PCS field in TDR is used to select the current peripheral. This means that the peripheral selection can be defined for each new data.

The Fixed Peripheral Selection allows buffer transfers with a single peripheral. Using the PDC is an optimal means, as the size of the data transfer between the memory and the SPI is either 8 bits or 16 bits. However, changing the peripheral selection requires the Mode Register to be reprogrammed.

The Variable Peripheral Selection allows buffer transfers with multiple peripherals without reprogramming the Mode Register. Data written in TDR is 32 bits wide and defines the real data to be transmitted and the peripheral it is destined to. Using the PDC in this mode requires 32-bit wide buffers, with the data in the LSBs and the PCS and LASTXFER fields in the MSBs, however the SPI still controls the number of bits (8 to 16) to be transferred through MISO and MOSI lines with the chip select configuration registers. This is not the optimal means in term of memory size for the buffers, but it provides a very effective means to exchange data with several peripherals without any intervention of the processor.

21.7.3.6 Peripheral Chip Select Decoding

The user can program the SPI to operate with up to 15 peripherals by decoding the four Chip Select lines, NPCS0 to NPCS3 with an external logic. This can be enabled by writing the PCS-DEC bit at 1 in the Mode Register (MR).

When operating without decoding, the SPI makes sure that in any case only one chip select line is activated, i.e. driven low at a time. If two bits are defined low in a PCS field, only the lowest numbered chip select is driven low.

When operating with decoding, the SPI directly outputs the value defined by the PCS field of either the Mode Register or the Transmit Data Register (depending on PS).

As the SPI sets a default value of 0xF on the chip select lines (i.e. all chip select lines at 1) when not processing any transfer, only 15 peripherals can be decoded.

The SPI has only four Chip Select Registers, not 15. As a result, when decoding is activated, each chip select defines the characteristics of up to four peripherals. As an example, CRS0 defines the characteristics of the externally decoded peripherals 0 to 3, corresponding to the PCS values 0x0 to 0x3. Thus, the user has to make sure to connect compatible peripherals on the decoded chip select lines 0 to 3, 4 to 7, 8 to 11 and 12 to 14.

21.7.3.7 Peripheral Deselection

When operating normally, as soon as the transfer of the last data written in TDR is completed, the NPCS lines all rise. This might lead to runtime error if the processor is too long in responding to an interrupt, and thus might lead to difficulties for interfacing with some serial peripherals requiring the chip select line to remain active during a full set of transfers.

To facilitate interfacing with such devices, the Chip Select Register can be programmed with the CSAAT bit (Chip Select Active After Transfer) at 1. This allows the chip select lines to remain in their current state (low = active) until transfer to another peripheral is required.

Figure 21-8 shows different peripheral deselection cases and the effect of the CSAAT bit.

Figure 21-8. Peripheral Deselection

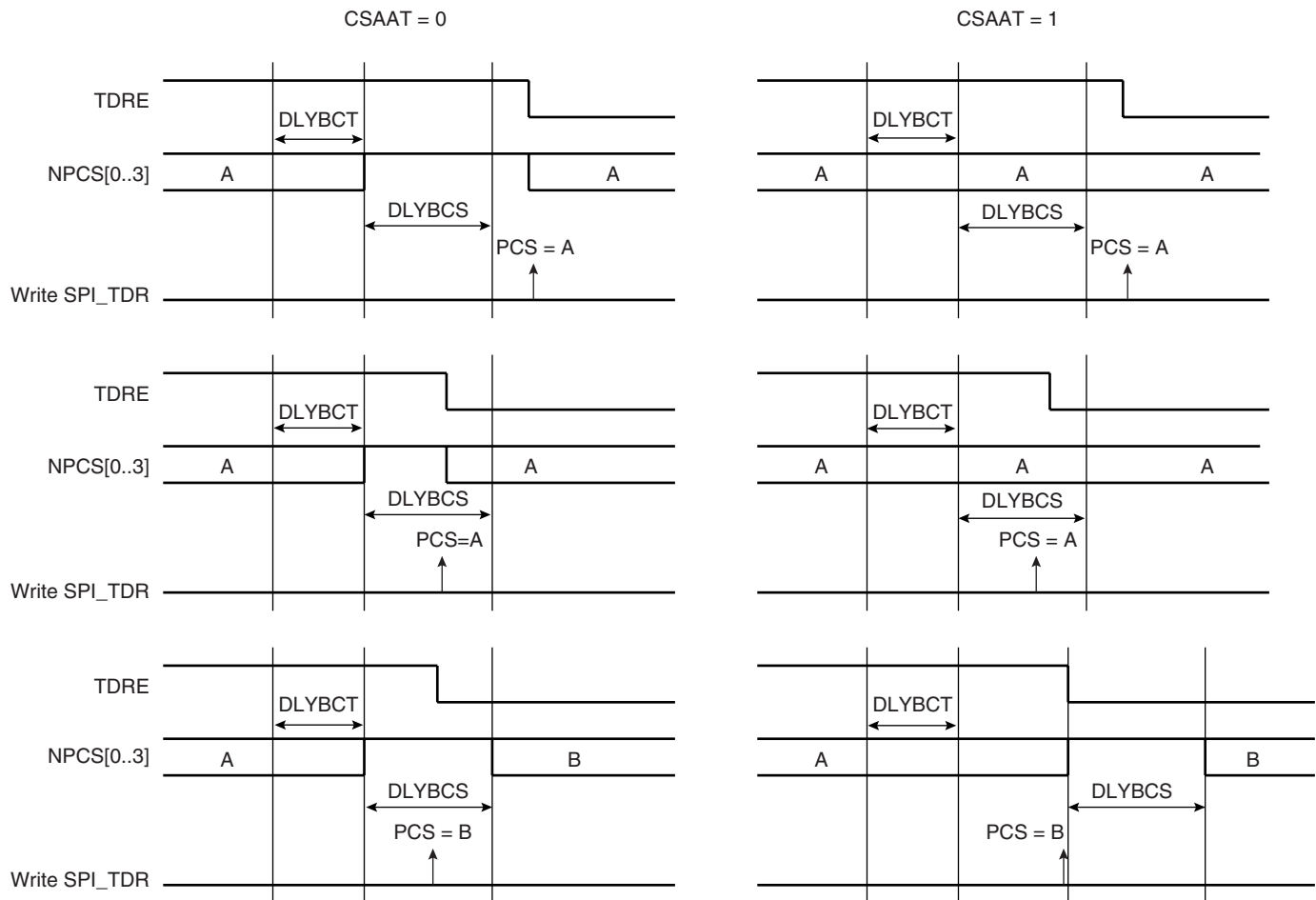

21.7.3.8 Mode Fault Detection

A mode fault is detected when the SPI is programmed in Master Mode and a low level is driven by an external master on the NPCSO/NSS signal. NPCSO, MOSI, MISO and SPCK must be configured in open-drain through the PIO controller, so that external pull up resistors are needed to guarantee high level.

When a mode fault is detected, the MODF bit in the SR is set until the SR is read and the SPI is automatically disabled until re-enabled by writing the SPIEN bit in the CR (Control Register) at 1.

By default, the Mode Fault detection circuitry is enabled. The user can disable Mode Fault detection by setting the MODFDIS bit in the SPI Mode Register (MR).

21.7.4 SPI Slave Mode

When operating in Slave Mode, the SPI processes data bits on the clock provided on the SPI clock pin (SPCK).

The SPI waits for NSS to go active before receiving the serial clock from an external master. When NSS falls, the clock is validated on the serializer, which processes the number of bits defined by the BITS field of the Chip Select Register 0 (CSR0). These bits are processed following a phase and a polarity defined respectively by the NCPHA and CPOL bits of the CSR0. Note that BITS, CPOL and NCPHA of the other Chip Select Registers have no effect when the SPI is programmed in Slave Mode.

The bits are shifted out on the MISO line and sampled on the MOSI line.

When all the bits are processed, the received data is transferred in the Receive Data Register and the RDRF bit rises. If RDRF is already high when the data is transferred, the Overrun bit rises and the data transfer to RDR is aborted.

When a transfer starts, the data shifted out is the data present in the Shift Register. If no data has been written in the Transmit Data Register (TDR), the last data received is transferred. If no data has been received since the last reset, all bits are transmitted low, as the Shift Register resets at 0.

When a first data is written in TDR, it is transferred immediately in the Shift Register and the TDRE bit rises. If new data is written, it remains in TDR until a transfer occurs, i.e. NSS falls and there is a valid clock on the SPCK pin. When the transfer occurs, the last data written in TDR is transferred in the Shift Register and the TDRE bit rises. This enables frequent updates of critical variables with single transfers.

Then, a new data is loaded in the Shift Register from the Transmit Data Register. In case no character is ready to be transmitted, i.e. no character has been written in TDR since the last load from TDR to the Shift Register, the Shift Register is not modified and the last received character is retransmitted.

Figure 21-9 shows a block diagram of the SPI when operating in Slave Mode.

Figure 21-9. Slave Mode Functional Block Diagram

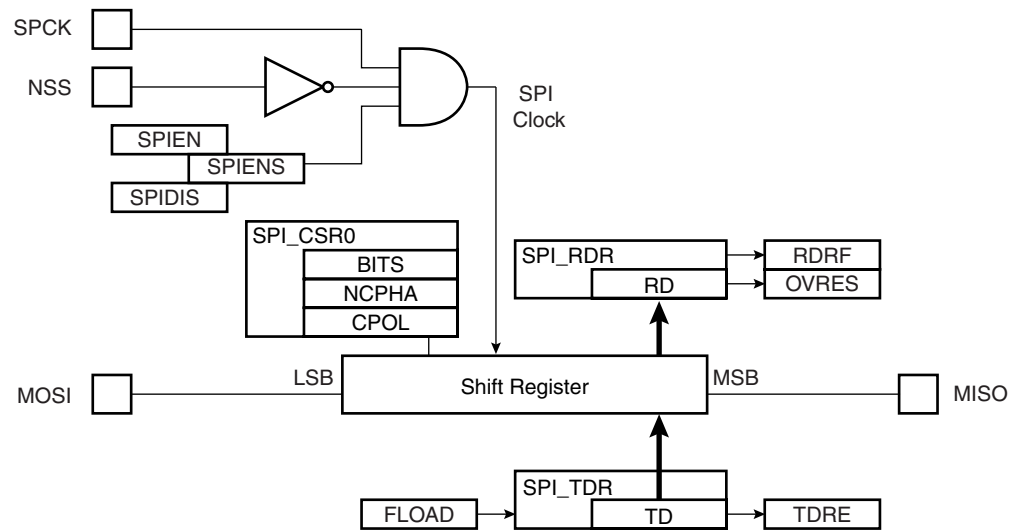

21.8 Serial Peripheral Interface (SPI) User Interface

Table 21-3. SPI Register Mapping

Offset	Register	Register Name	Access	Reset
0x00	Control Register	CR	Write-only	---
0x04	Mode Register	MR	Read/Write	0x0
0x08	Receive Data Register	RDR	Read-only	0x0
0x0C	Transmit Data Register	TDR	Write-only	---
0x10	Status Register	SR	Read-only	0x000000F0
0x14	Interrupt Enable Register	IER	Write-only	---
0x18	Interrupt Disable Register	IDR	Write-only	---
0x1C	Interrupt Mask Register	IMR	Read-only	0x0
0x20 - 0x2C	Reserved			
0x30	Chip Select Register 0	CSR0	Read/Write	0x0
0x34	Chip Select Register 1	CSR1	Read/Write	0x0
0x38	Chip Select Register 2	CSR2	Read/Write	0x0
0x3C	Chip Select Register 3	CSR3	Read/Write	0x0
0x100 - 0x124	Reserved for the PDC			

21.8.1 SPI Control Register

Name: CR

Access Type: Write-only

31	30	29	28	27	26	25	24
–	–	–	–	–	–	–	LASTXFER
23	22	21	20	19	18	17	16
–	–	–	–	–	–	–	–
15	14	13	12	11	10	9	8
–	–	–	–	–	–	–	–
7	6	5	4	3	2	1	0
SWRST	–	–	–	–	–	SPIDIS	SPIEN

- **SPIEN: SPI Enable**

0 = No effect.

1 = Enables the SPI to transfer and receive data.

- **SPIDIS: SPI Disable**

0 = No effect.

1 = Disables the SPI.

As soon as SPDIS is set, SPI finishes its transfer.

All pins are set in input mode and no data is received or transmitted.

If a transfer is in progress, the transfer is finished before the SPI is disabled.

If both SPIEN and SPIDIS are equal to one when the control register is written, the SPI is disabled.

- **SWRST: SPI Software Reset**

0 = No effect.

1 = Reset the SPI. A software-triggered hardware reset of the SPI interface is performed.

The SPI is in slave mode after a software reset.

PDC channels are not affected by software reset.

- **LASTXFER: Last Transfer**

0 = No effect.

1 = The current NPCS will be deasserted after the character written in TD has been transferred. When CSAAT is set, this allows to close the communication with the current serial peripheral by raising the corresponding NPCS line as soon as TD transfer has completed.

21.8.2 SPI Mode Register

Name: MR
Access Type: Read/Write

31	30	29	28	27	26	25	24
DLYBCS							
23	22	21	20	19	18	17	16
–	–	–	–	PCS			
15	14	13	12	11	10	9	8
–	–	–	–	–	–	–	–
7	6	5	4	3	2	1	0
LLB	–	–	MODFDIS	FDIV	PCSDEC	PS	MSTR

- **MSTR: Master/Slave Mode**

0 = SPI is in Slave mode.

1 = SPI is in Master mode.

- **PS: Peripheral Select**

0 = Fixed Peripheral Select.

1 = Variable Peripheral Select.

- **PCSDEC: Chip Select Decode**

0 = The chip selects are directly connected to a peripheral device.

1 = The four chip select lines are connected to a 4- to 16-bit decoder.

When PCSDEC equals one, up to 15 Chip Select signals can be generated with the four lines using an external 4- to 16-bit decoder. The Chip Select Registers define the characteristics of the 15 chip selects according to the following rules:

CSR0 defines peripheral chip select signals 0 to 3.

CSR1 defines peripheral chip select signals 4 to 7.

CSR2 defines peripheral chip select signals 8 to 11.

CSR3 defines peripheral chip select signals 12 to 14.

- **FDIV: Clock Selection**

0 = The SPI operates at MCK.

1 = The SPI operates at MCK/N.

- **MODFDIS: Mode Fault Detection**

0 = Mode fault detection is enabled.

1 = Mode fault detection is disabled.

- **LLB: Local Loopback Enable**

0 = Local loopback path disabled.

1 = Local loopback path enabled.

LLB controls the local loopback on the data serializer for testing in Master Mode only. MISO is internally connected to MOSI.

- **PCS: Peripheral Chip Select**

This field is only used if Fixed Peripheral Select is active (PS = 0).

If PCSDEC = 0:

PCS = xxx0	NPCS[3:0] = 1110
PCS = xx01	NPCS[3:0] = 1101
PCS = x011	NPCS[3:0] = 1011
PCS = 0111	NPCS[3:0] = 0111
PCS = 1111	forbidden (no peripheral is selected)

(x = don't care)

If PCSDEC = 1:

NPCS[3:0] output signals = PCS.

- **DLYBCS: Delay Between Chip Selects**

This field defines the delay from NPCS inactive to the activation of another NPCS. The DLYBCS time guarantees non-overlapping chip selects and solves bus contentions in case of peripherals having long data float times.

If DLYBCS is less than or equal to six, six MCK periods (or 6*N MCK periods if FDIV is set) will be inserted by default.

Otherwise, the following equation determines the delay:

If FDIV is 0:

$$\text{Delay Between Chip Selects} = \frac{DLYBCS}{MCK}$$

If FDIV is 1:

$$\text{Delay Between Chip Selects} = \frac{DLYBCS \times N}{MCK}$$

21.8.3 SPI Receive Data Register

Name: RDR

Access Type: Read-only

31	30	29	28	27	26	25	24
–	–	–	–	–	–	–	–
23	22	21	20	19	18	17	16
–	–	–	–	PCS			
15	14	13	12	11	10	9	8
RD							
7	6	5	4	3	2	1	0
RD							

- **RD: Receive Data**

Data received by the SPI Interface is stored in this register right-justified. Unused bits read zero.

- **PCS: Peripheral Chip Select**

In Master Mode only, these bits indicate the value on the NPCS pins at the end of a transfer. Otherwise, these bits read zero.

21.8.4 SPI Transmit Data Register

Name: TDR
Access Type: Write-only

31	30	29	28	27	26	25	24
–	–	–	–	–	–	–	LASTXFER
23	22	21	20	19	18	17	16
–	–	–	–	PCS			
15	14	13	12	11	10	9	8
TD							
7	6	5	4	3	2	1	0
TD							

- **TD: Transmit Data**

Data to be transmitted by the SPI Interface is stored in this register. Information to be transmitted must be written to the transmit data register in a right-justified format.

- **PCS: Peripheral Chip Select**

This field is only used if Variable Peripheral Select is active (PS = 1).

If PCSDEC = 0:

PCS = xxx0	NPCS[3:0] = 1110
PCS = xx01	NPCS[3:0] = 1101
PCS = x011	NPCS[3:0] = 1011
PCS = 0111	NPCS[3:0] = 0111
PCS = 1111	forbidden (no peripheral is selected)

(x = don't care)

If PCSDEC = 1:

NPCS[3:0] output signals = PCS

- **LASTXFER: Last Transfer**

0 = No effect.

1 = The current NPCS will be deasserted after the character written in TD has been transferred. When CSAAT is set, this allows to close the communication with the current serial peripheral by raising the corresponding NPCS line as soon as TD transfer has completed.

This field is only used if Variable Peripheral Select is active (PS = 1).

21.8.5 SPI Status Register

Name: SR

Access Type: Read-only

31	30	29	28	27	26	25	24
–	–	–	–	–	–	–	–
23	22	21	20	19	18	17	16
–	–	–	–	–	–	–	SPIENS
15	14	13	12	11	10	9	8
–	–	–	–	–	–	TXEMPTY	NSSR
7	6	5	4	3	2	1	0
TXBUFE	RXBUFF	ENDTX	ENDRX	OVRES	MODF	TDRE	RDRF

- **RDRF: Receive Data Register Full**

0 = No data has been received since the last read of RDR

1 = Data has been received and the received data has been transferred from the serializer to RDR since the last read of RDR.

- **TDRE: Transmit Data Register Empty**

0 = Data has been written to TDR and not yet transferred to the serializer.

1 = The last data written in the Transmit Data Register has been transferred to the serializer.

TDRE equals zero when the SPI is disabled or at reset. The SPI enable command sets this bit to one.

- **MODF: Mode Fault Error**

0 = No Mode Fault has been detected since the last read of SR.

1 = A Mode Fault occurred since the last read of the SR.

- **OVRES: Overrun Error Status**

0 = No overrun has been detected since the last read of SR.

1 = An overrun has occurred since the last read of SR.

An overrun occurs when RDR is loaded at least twice from the serializer since the last read of the RDR.

- **ENDRX: End of RX buffer**

0 = The Receive Counter Register has not reached 0 since the last write in RCR or RNCR.

1 = The Receive Counter Register has reached 0 since the last write in RCR or RNCR.

- **ENDTX: End of TX buffer**

0 = The Transmit Counter Register has not reached 0 since the last write in TCR or TNCR.

1 = The Transmit Counter Register has reached 0 since the last write in TCR or TNCR.

- **RXBUFF: RX Buffer Full**

0 = RCR or RNCR has a value other than 0.

1 = Both RCR and RNCR has a value of 0.

- **TXBUFE: TX Buffer Empty**

0 = TCR or TNCR has a value other than 0.

1 = Both TCR and TNCR has a value of 0.

- **NSSR: NSS Rising**

0 = No rising edge detected on NSS pin since last read.

1 = A rising edge occurred on NSS pin since last read.

- **TXEMPTY: Transmission Registers Empty**

0 = As soon as data is written in TDR.

1 = TDR and internal shifter are empty. If a transfer delay has been defined, TXEMPTY is set after the completion of such delay.

- **SPIENS: SPI Enable Status**

0 = SPI is disabled.

1 = SPI is enabled.

21.8.6 SPI Interrupt Enable Register

Name: IER

Access Type: Write-only

31	30	29	28	27	26	25	24
–	–	–	–	–	–	–	–
23	22	21	20	19	18	17	16
–	–	–	–	–	–	–	–
15	14	13	12	11	10	9	8
–	–	–	–	–	–	TXEMPTY	NSSR
7	6	5	4	3	2	1	0
TXBUFE	RXBUFF	ENDTX	ENDRX	OVRES	MODF	TDRE	RDRF

- **RDRF: Receive Data Register Full Interrupt Enable**
- **TDRE: SPI Transmit Data Register Empty Interrupt Enable**
- **MODF: Mode Fault Error Interrupt Enable**
- **OVRES: Overrun Error Interrupt Enable**
- **ENDRX: End of Receive Buffer Interrupt Enable**
- **ENDTX: End of Transmit Buffer Interrupt Enable**
- **RXBUFF: Receive Buffer Full Interrupt Enable**
- **TXBUFE: Transmit Buffer Empty Interrupt Enable**
- **TXEMPTY: Transmission Registers Empty Enable**
- **NSSR: NSS Rising Interrupt Enable**

0 = No effect.

1 = Enables the corresponding interrupt.

21.8.7 SPI Interrupt Disable Register

Name: IDR

Access Type: Write-only

31	30	29	28	27	26	25	24
–	–	–	–	–	–	–	–
23	22	21	20	19	18	17	16
–	–	–	–	–	–	–	–
15	14	13	12	11	10	9	8
–	–	–	–	–	–	TXEMPTY	NSSR
7	6	5	4	3	2	1	0
TXBUFE	RXBUFF	ENDTX	ENDRX	OVRES	MODF	TDRE	RDRF

- **RDRF: Receive Data Register Full Interrupt Disable**
- **TDRE: SPI Transmit Data Register Empty Interrupt Disable**
- **MODF: Mode Fault Error Interrupt Disable**
- **OVRES: Overrun Error Interrupt Disable**
- **ENDRX: End of Receive Buffer Interrupt Disable**
- **ENDTX: End of Transmit Buffer Interrupt Disable**
- **RXBUFF: Receive Buffer Full Interrupt Disable**
- **TXBUFE: Transmit Buffer Empty Interrupt Disable**
- **TXEMPTY: Transmission Registers Empty Disable**
- **NSSR: NSS Rising Interrupt Disable**

0 = No effect.

1 = Disables the corresponding interrupt.

21.8.8 SPI Interrupt Mask Register

Name: IMR

Access Type: Read-only

31	30	29	28	27	26	25	24
–	–	–	–	–	–	–	–
23	22	21	20	19	18	17	16
–	–	–	–	–	–	–	–
15	14	13	12	11	10	9	8
–	–	–	–	–	–	TXEMPTY	NSSR
7	6	5	4	3	2	1	0
TXBUFE	RXBUFF	ENDTX	ENDRX	OVRES	MODF	TDRE	RDRF

- **RDRF: Receive Data Register Full Interrupt Mask**
- **TDRE: SPI Transmit Data Register Empty Interrupt Mask**
- **MODF: Mode Fault Error Interrupt Mask**
- **OVRES: Overrun Error Interrupt Mask**
- **ENDRX: End of Receive Buffer Interrupt Mask**
- **ENDTX: End of Transmit Buffer Interrupt Mask**
- **RXBUFF: Receive Buffer Full Interrupt Mask**
- **TXBUFE: Transmit Buffer Empty Interrupt Mask**
- **TXEMPTY: Transmission Registers Empty Mask**
- **NSSR: NSS Rising Interrupt Mask**

0 = The corresponding interrupt is not enabled.

1 = The corresponding interrupt is enabled.

21.8.9 SPI Chip Select Register

Name: CSR0... CSR3

Access Type: Read/Write

31	30	29	28	27	26	25	24
DLYBCT							
23	22	21	20	19	18	17	16
DLYBS							
15	14	13	12	11	10	9	8
SCBR							
7	6	5	4	3	2	1	0
BITS				CSAAT	–	NCPHA	CPOL

- **CPOL: Clock Polarity**

0 = The inactive state value of SPCK is logic level zero.

1 = The inactive state value of SPCK is logic level one.

CPOL is used to determine the inactive state value of the serial clock (SPCK). It is used with NCPHA to produce the required clock/data relationship between master and slave devices.

- **NCPHA: Clock Phase**

0 = Data is changed on the leading edge of SPCK and captured on the following edge of SPCK.

1 = Data is captured on the leading edge of SPCK and changed on the following edge of SPCK.

NCPHA determines which edge of SPCK causes data to change and which edge causes data to be captured. NCPHA is used with CPOL to produce the required clock/data relationship between master and slave devices.

- **CSAAT: Chip Select Active After Transfer**

0 = The Peripheral Chip Select Line rises as soon as the last transfer is achieved.

1 = The Peripheral Chip Select does not rise after the last transfer is achieved. It remains active until a new transfer is requested on a different chip select.

- **BITS: Bits Per Transfer**

The BITS field determines the number of data bits transferred. Reserved values should not be used, see [Table 21-4 on page 307](#).

Table 21-4. BITS, Bits Per Transfer

BITS	Bits Per Transfer
0000	8
0001	9
0010	10
0011	11
0100	12
0101	13
0110	14
0111	15
1000	16
1001	Reserved
1010	Reserved
1011	Reserved
1100	Reserved
1101	Reserved
1110	Reserved
1111	Reserved

• **SCBR: Serial Clock Baud Rate**

In Master Mode, the SPI Interface uses a modulus counter to derive the SPCK baud rate from the Master Clock MCK. The Baud rate is selected by writing a value from 1 to 255 in the SCBR field. The following equations determine the SPCK baud rate:

If FDIV is 0:

$$\text{SPCK Baudrate} = \frac{MCK}{SCBR}$$

If FDIV is 1:

$$\text{SPCK Baudrate} = \frac{MCK}{(N \times SCBR)}$$

Note: N = 32

Programming the SCBR field at 0 is forbidden. Triggering a transfer while SCBR is at 0 can lead to unpredictable results. At reset, SCBR is 0 and the user has to program it at a valid value before performing the first transfer.

• **DLYBS: Delay Before SPCK**

This field defines the delay from NPCS valid to the first valid SPCK transition.

When DLYBS equals zero, the NPCS valid to SPCK transition is 1/2 the SPCK clock period.



Otherwise, the following equations determine the delay:

If FDIV is 0:

$$\text{Delay Before SPCK} = \frac{DLYBS}{MCK}$$

If FDIV is 1:

$$\text{Delay Before SPCK} = \frac{N \times DLYBS}{MCK}$$

Note: N = 32

- **DLYBCT: Delay Between Consecutive Transfers**

This field defines the delay between two consecutive transfers with the same peripheral without removing the chip select. The delay is always inserted after each transfer and before removing the chip select if needed.

When DLYBCT equals zero, no delay between consecutive transfers is inserted and the clock keeps its duty cycle over the character transfers.

Otherwise, the following equation determines the delay:

If FDIV is 0:

$$\text{Delay Between Consecutive Transfers} = \frac{32 \times DLYBCT}{MCK} + \frac{SCBR}{2MCK}$$

If FDIV is 1:

$$\text{Delay Between Consecutive Transfers} = \frac{32 \times N \times DLYBCT}{MCK} + \frac{N \times SCBR}{2MCK}$$

N = 32

22. Two-wire Interface (TWI)

Rev: 1.8.0.0

22.1 Features

- Compatible with Philips' I²C protocol
- One, Two or Three Bytes for Slave Address
- Sequential Read/Write Operations

22.2 Description

The Two-wire Interface (TWI) interconnects components on a unique two-wire bus, made up of one clock line and one data line with speeds of up to 400 Kbits per second, based on a byte-oriented transfer format. It can be used with any Atmel two-wire bus Serial EEPROM. The TWI is programmable as a master with sequential or single-byte access. A configurable baud rate generator permits the output data rate to be adapted to a wide range of core clock frequencies.

22.3 Block Diagram

Figure 22-1. Block Diagram

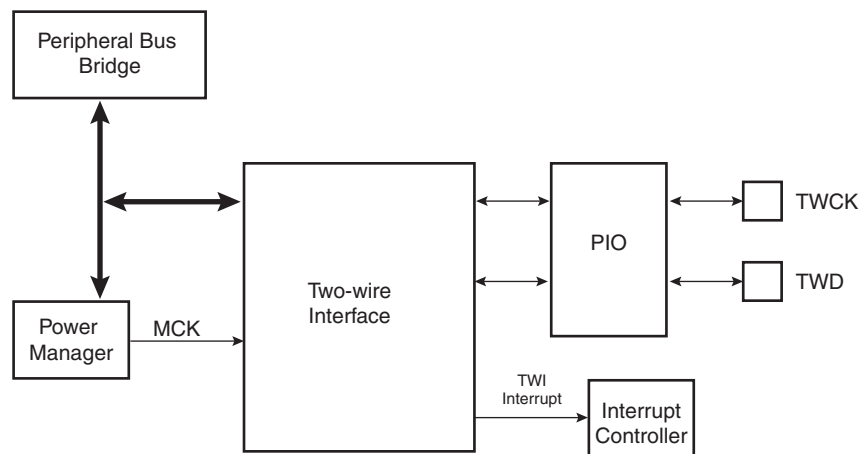

22.4 Application Block Diagram

Figure 22-2. Application Block Diagram

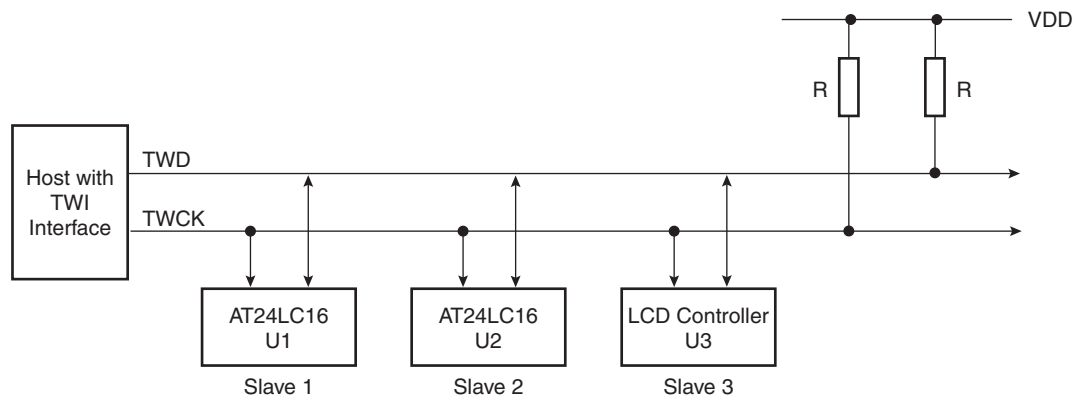

22.4.1 I/O Lines Description

Table 22-1. I/O Lines Description

Pin Name	Pin Description	Type
TWD	Two-wire Serial Data	Input/Output
TWCK	Two-wire Serial Clock	Input/Output

22.5 Product Dependencies

22.5.1 I/O Lines

Both TWD and TWCK are bi-directional lines, connected to a positive supply voltage via a current source or pull-up resistor (see [Figure 22-2 on page 309](#)). When the bus is free, both lines are high. The output stages of devices connected to the bus must have an open-drain or open-collector to perform the wired-AND function.

TWD and TWCK pins may be multiplexed with PIO lines. To enable the TWI, the programmer must program the PIO controller to dedicate TWD and TWCK as peripheral lines.

22.5.2 Power Management

The TWI clock is generated by the power manager. Before using the TWI, the programmer must ensure that the TWI clock is enabled in the power manager.

In the TWI description, Master Clock (MCK) is the clock of the peripheral bus to which the TWI is connected.

22.5.3 Interrupt

The TWI interface has an interrupt line connected to the interrupt controller. In order to handle interrupts, the interrupt controller must be programmed before configuring the TWI.

22.6 Functional Description

22.6.1 Transfer format

The data put on the TWD line must be 8 bits long. Data is transferred MSB first; each byte must be followed by an acknowledgement. The number of bytes per transfer is unlimited (see [Figure 22-4 on page 311](#)).

Each transfer begins with a START condition and terminates with a STOP condition (see [Figure 22-3 on page 311](#)).

- A high-to-low transition on the TWD line while TWCK is high defines the START condition.
- A low-to-high transition on the TWD line while TWCK is high defines a STOP condition.

Figure 22-3. START and STOP Conditions

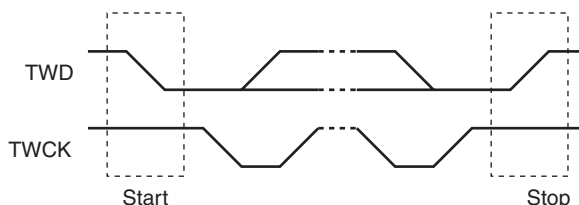
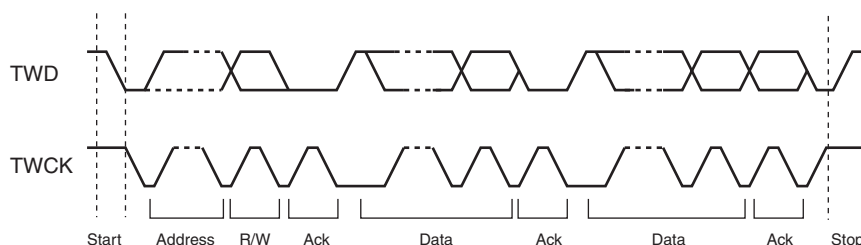

Figure 22-4. Transfer Format



22.6.2 Modes of Operation

The TWI has two modes of operation:

- Master transmitter mode
- Master receiver mode

The TWI Control Register (CR) allows configuration of the interface in Master Mode. In this mode, it generates the clock according to the value programmed in the Clock Waveform Generator Register (CWGR). This register defines the TWCK signal completely, enabling the interface to be adapted to a wide range of clocks.

22.6.3 Transmitting Data

After the master initiates a Start condition, it sends a 7-bit slave address, configured in the Master Mode register (DADR in MMR), to notify the slave device. The bit following the slave address indicates the transfer direction (write or read). If this bit is 0, it indicates a write operation (transmit operation). If the bit is 1, it indicates a request for data read (receive operation).

The TWI transfers require the slave to acknowledge each received byte. During the acknowledge clock pulse, the master releases the data line (HIGH), enabling the slave to pull it down in order to generate the acknowledge. The master polls the data line during this clock pulse and sets the **NAK** bit in the status register if the slave does not acknowledge the byte. As with the

other status bits, an interrupt can be generated if enabled in the interrupt enable register (IER). After writing in the transmit-holding register (THR), setting the START bit in the control register starts the transmission. The data is shifted in the internal shifter and when an acknowledge is detected, the TXRDY bit is set until a new write in the THR (see Figure 22-6 below). The master generates a stop condition to end the transfer.

The read sequence begins by setting the START bit. When the RXRDY bit is set in the status register, a character has been received in the receive-holding register (RHR). The RXRDY bit is reset when reading the RHR.

The TWI interface performs various transfer formats (7-bit slave address, 10-bit slave address). The three internal address bytes are configurable through the Master Mode register (MMR). If the slave device supports only a 7-bit address, **IADRSZ** must be set to 0. For a slave address higher than 7 bits, the user must configure the address size (**IADRSZ**) and set the other slave address bits in the internal address register (IADR).

Figure 22-5. Master Write with One, Two or Three Bytes Internal Address and One Data Byte



Figure 22-6. Master Write with One Byte Internal Address and Multiple Data Bytes

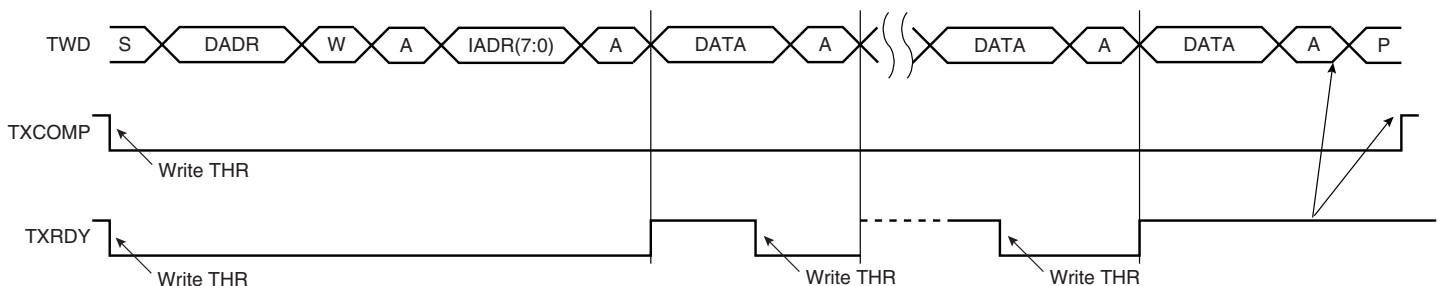

Figure 22-7. Master Read with One, Two or Three Bytes Internal Address and One Data Byte

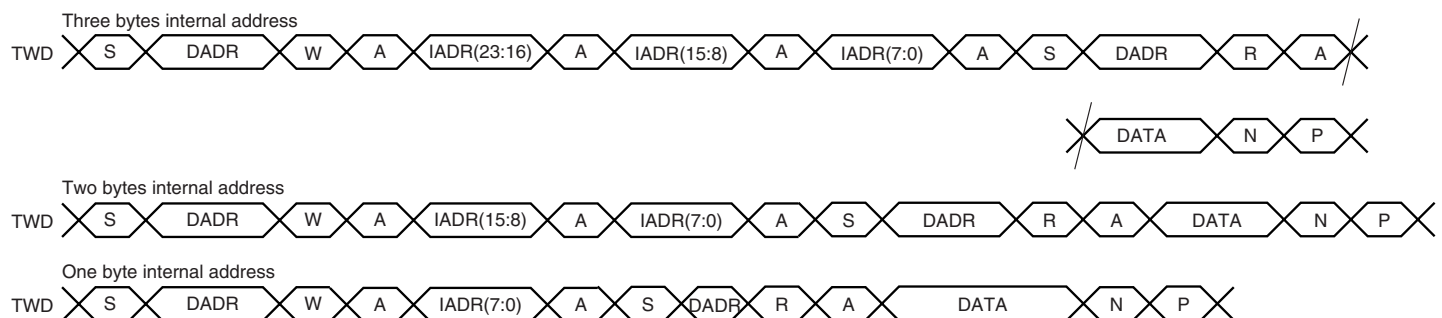
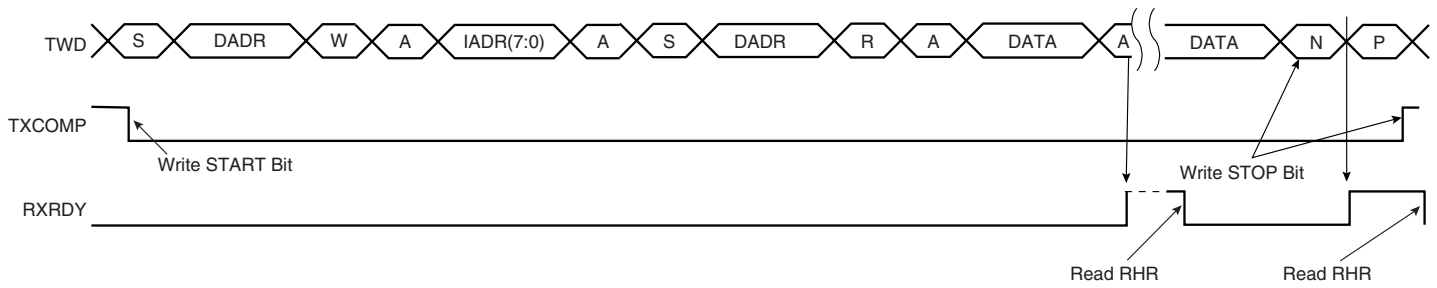

Figure 22-8. Master Read with One Byte Internal Address and Multiple Data Bytes



- S = Start
- P = Stop
- W = Write
- R = Read
- A = Acknowledge
- N = Not Acknowledge
- DADR= Device Address
- IADR = Internal Address

Figure 22-9 below shows a byte write to an Atmel AT24LC512 EEPROM. This demonstrates the use of internal addresses to access the device.

Figure 22-9. Internal Address Usage

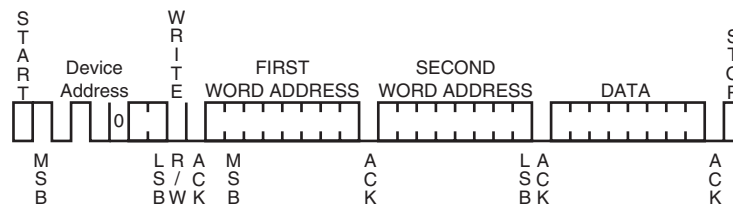

22.6.4 Read/Write Flowcharts

The following flowcharts shown in [Figure 22-10 on page 314](#) and in [Figure 22-11 on page 315](#) give examples for read and write operations in Master Mode. A polling or interrupt method can be used to check the status bits. The interrupt method requires that the interrupt enable register (IER) be configured first.

Figure 22-10. TWI Write in Master Mode

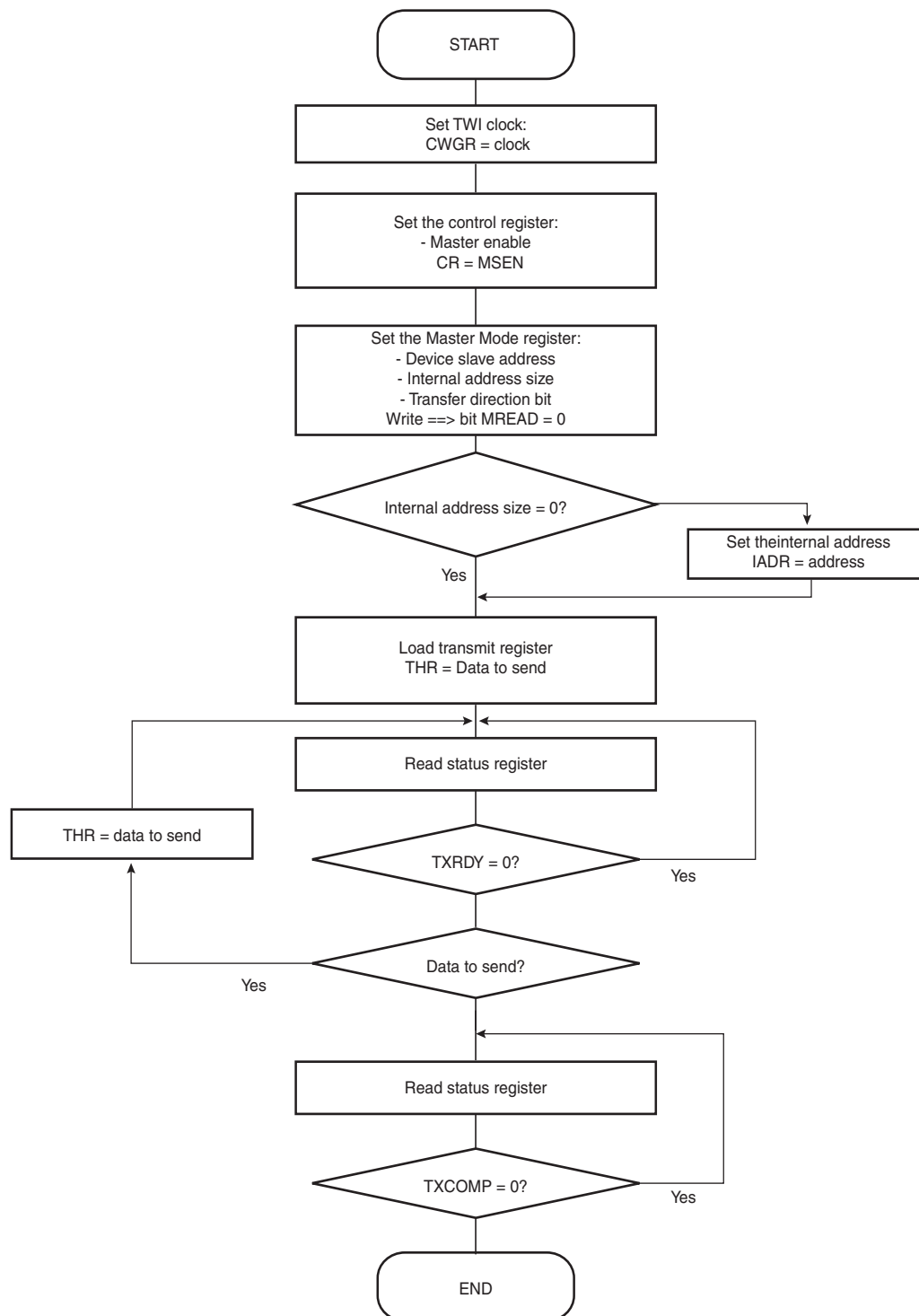
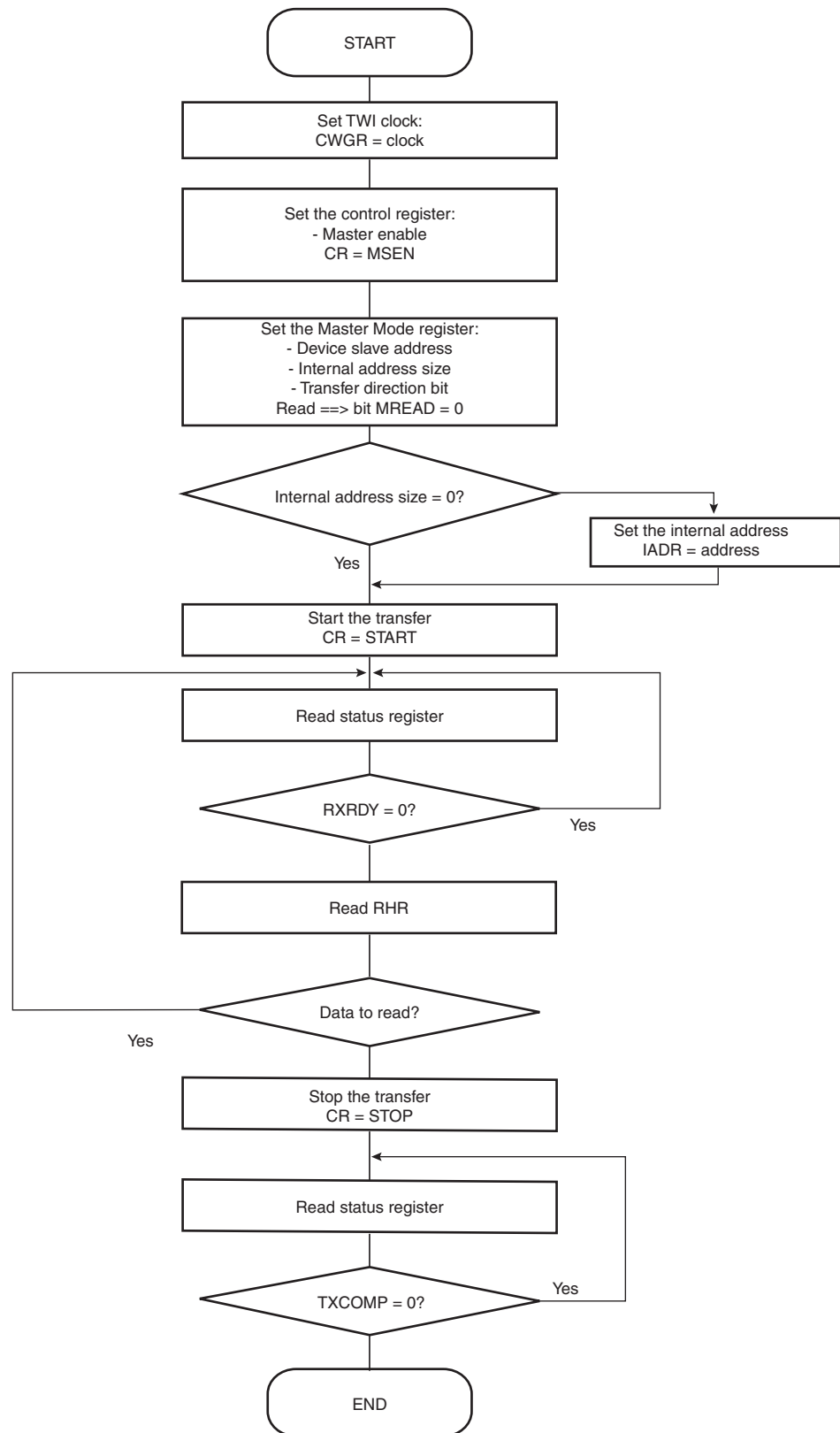

Figure 22-11. TWI Read in Master Mode



22.7 TWI User Interface

22.7.1 Register Mapping

Table 22-2. Two-wire Interface (TWI) User Interface

Offset	Register	Name	Access	Reset Value
0x0000	Control Register	CR	Write-only	N/A
0x0004	Master Mode Register	MMR	Read/Write	0x0000
0x0008	Reserved	-	-	-
0x000C	Internal Address Register	IADR	Read/Write	0x0000
0x0010	Clock Waveform Generator Register	CWGR	Read/Write	0x0000
0x0020	Status Register	SR	Read-only	0x0008
0x0024	Interrupt Enable Register	IER	Write-only	N/A
0x0028	Interrupt Disable Register	IDR	Write-only	N/A
0x002C	Interrupt Mask Register	IMR	Read-only	0x0000
0x0030	Receive Holding Register	RHR	Read-only	0x0000
0x0034	Transmit Holding Register	THR	Read/Write	0x0000

22.7.2 TWI Control Register

Register Name:

CR

Access Type:

Write-only

31	30	29	28	27	26	25	24
–	–	–	–	–	–	–	–
23	22	21	20	19	18	17	16
–	–	–	–	–	–	–	–
15	14	13	12	11	10	9	8
–	–	–	–	–	–	–	–
7	6	5	4	3	2	1	0
SWRST	–	–	–	MSDIS	MSEN	STOP	START

- **START: Send a START Condition**

0 = No effect.

1 = A frame beginning with a START bit is transmitted according to the settings in the mode register.

This action is necessary when the TWI peripheral wants to read data from a slave. When configured in Master Mode with a write operation, a frame is sent with the mode register as soon as the user writes a character in the holding register.

- **STOP: Send a STOP Condition**

0 = No effect.

1 = STOP Condition is sent just after completing the current byte transmission in master read or write mode.

In single data byte master read or write, the START and STOP must both be set.

In multiple data bytes master read or write, the STOP must be set before ACK/NACK bit transmission.

In master read mode, if a NACK bit is received, the STOP is automatically performed.

In multiple data write operation, when both THR and shift register are empty, a STOP condition is automatically sent.

- **MSEN: TWI Master Transfer Enabled**

0 = No effect.

1 = If MSDIS = 0, the master data transfer is enabled.

- **MSDIS: TWI Master Transfer Disabled**

0 = No effect.

1 = The master data transfer is disabled, all pending data is transmitted. The shifter and holding characters (if they contain data) are transmitted in case of write operation. In read operation, the character being transferred must be completely received before disabling.

- **SWRST: Software Reset**

0 = No effect.

1 = Equivalent to a system reset.

22.7.3 TWI Master Mode Register

Register Name: MMR
 Address Type: Read/Write

31	30	29	28	27	26	25	24
–	–	–	–	–	–	–	–
23	22	21	20	19	18	17	16
–	DADR						
15	14	13	12	11	10	9	8
–	–	–	MREAD	–	–	IADRSZ	
7	6	5	4	3	2	1	0
–	–	–	–	–	–	–	–

- **IADRSZ: Internal Device Address Size**

IADRSZ[9:8]		
0	0	No internal device address (Byte command protocol)
0	1	One-byte internal device address
1	0	Two-byte internal device address
1	1	Three-byte internal device address

- **MREAD: Master Read Direction**

0 = Master write direction.

1 = Master read direction.

- **DADR: Device Address**

The device address is used in Master Mode to access slave devices in read or write mode.

22.7.4 TWI Internal Address Register

Register Name: IADR
 Access Type: Read/Write

31	30	29	28	27	26	25	24
–	–	–	–	–	–	–	–
23	22	21	20	19	18	17	16
IADR							
15	14	13	12	11	10	9	8
IADR							
7	6	5	4	3	2	1	0
IADR							

• **IADR: Internal Address**

0, 1, 2 or 3 bytes depending on IADRSZ.

- Low significant byte address in 10-bit mode addresses.

22.7.5 TWI Clock Waveform Generator Register

Register Name:

CWGR

Access Type:

Read/Write

31	30	29	28	27	26	25	24
–	–	–	–	–	–	–	–
23	22	21	20	19	18	17	16
–	–	–	–	–	CKDIV		
15	14	13	12	11	10	9	8
CHDIV							
7	6	5	4	3	2	1	0
CLDIV							

- **CLDIV: Clock Low Divider**

The SCL low period is defined as follows:

$$T_{low} = ((CLDIV \times 2^{CKDIV}) + 3) \times T_{MCK}$$

- **CHDIV: Clock High Divider**

The SCL high period is defined as follows:

$$T_{high} = ((CHDIV \times 2^{CKDIV}) + 3) \times T_{MCK}$$

- **CKDIV: Clock Divider**

The CKDIV is used to increase both SCL high and low periods.

22.7.6 TWI Status Register

Register Name:

SR

Access Type:

Read-only

31	30	29	28	27	26	25	24
–	–	–	–	–	–	–	–
23	22	21	20	19	18	17	16
–	–	–	–	–	–	–	–
15	14	13	12	11	10	9	8
–	–	–	–	–	–	–	NACK
7	6	5	4	3	2	1	0
–	–	–	–	–	TXRDY	RXRDY	TXCOMP

- **TXCOMP: Transmission Completed**

0 = In master, during the length of the current frame. In slave, from START received to STOP received.

1 = When both holding and shift registers are empty and STOP condition has been sent (in Master), or when MSEN is set (enable TWI).

- **RXRDY: Receive Holding Register Ready**

0 = No character has been received since the last RHR read operation.

1 = A byte has been received in the RHR since the last read.

- **TXRDY: Transmit Holding Register Ready**

0 = The transmit holding register has not been transferred into shift register. Set to 0 when writing into THR register.

1 = As soon as data byte is transferred from THR to internal shifter or if a NACK error is detected, TXRDY is set at the same time as TXCOMP and NACK. TXRDY is also set when MSEN is set (enable TWI).

- **NACK: Not Acknowledged**

0 = Each data byte has been correctly received by the far-end side TWI slave component.

1 = A data byte has not been acknowledged by the slave component. Set at the same time as TXCOMP. Reset after read.

22.7.7 TWI Interrupt Enable Register

Register Name: IER
 Access Type: Write-only

31	30	29	28	27	26	25	24
-	-	-	-	-	-	-	-
23	22	21	20	19	18	17	16
-	-	-	-	-	-	-	-
15	14	13	12	11	10	9	8
-	-	-	-	-	-	-	NACK
7	6	5	4	3	2	1	0
-	-	-	-	-	TXRDY	RXRDY	TXCOMP

- **TXCOMP: Transmission Completed**
- **RXRDY: Receive Holding Register Ready**
- **TXRDY: Transmit Holding Register Ready**
- **NACK: Not Acknowledge**

0 = No effect.

1 = Enables the corresponding interrupt.

22.7.8 TWI Interrupt Disable Register

Register Name:

IDR

Access Type:

Write-only

31	30	29	28	27	26	25	24
–	–	–	–	–	–	–	–
23	22	21	20	19	18	17	16
–	–	–	–	–	–	–	–
15	14	13	12	11	10	9	8
–	–	–	–	–	–	–	NACK
7	6	5	4	3	2	1	0
–	–	–	–	–	TXRDY	RXRDY	TXCOMP

- **TXCOMP: Transmission Completed**
- **RXRDY: Receive Holding Register Ready**
- **TXRDY: Transmit Holding Register Ready**
- **NACK: Not Acknowledge**

0 = No effect.

1 = Disables the corresponding interrupt.

22.7.9 TWI Interrupt Mask Register

Register Name:

IMR

Access Type:

Read-only

31	30	29	28	27	26	25	24
–	–	–	–	–	–	–	–
23	22	21	20	19	18	17	16
–	–	–	–	–	–	–	–
15	14	13	12	11	10	9	8
–	–	–	–	–	–	–	NACK
7	6	5	4	3	2	1	0
–	–	–	–	–	TXRDY	RXRDY	TXCOMP

- **TXCOMP: Transmission Completed**
- **RXRDY: Receive Holding Register Ready**
- **TXRDY: Transmit Holding Register Ready**
- **NACK: Not Acknowledge**

0 = The corresponding interrupt is disabled.

1 = The corresponding interrupt is enabled.

22.7.10 TWI Receive Holding Register

Register Name:

RHR

Access Type:

Read-only

31	30	29	28	27	26	25	24
–	–	–	–	–	–	–	–
23	22	21	20	19	18	17	16
–	–	–	–	–	–	–	–
15	14	13	12	11	10	9	8
–	–	–	–	–	–	–	–
7	6	5	4	3	2	1	0
RXDATA							

- **RXDATA: Master or Slave Receive Holding Data**

22.7.11 TWI Transmit Holding Register

Register Name:

THR

Access Type:

Read/Write

31	30	29	28	27	26	25	24
–	–	–	–	–	–	–	–
23	22	21	20	19	18	17	16
–	–	–	–	–	–	–	–
15	14	13	12	11	10	9	8
–	–	–	–	–	–	–	–
7	6	5	4	3	2	1	0
TXDATA							

- **TXDATA: Master or Slave Transmit Holding Data**

23. PS/2 Module (PSIF)

Rev: 1.0.0.0

23.1 Features

- **PS/2 Host**
- **Receive and transmit capability**
- **Parity generation and error detection**
- **Overrun error detection**

23.2 Description

The PS/2 module provides host functionality allowing the MCU to interface PS/2 devices such as keyboard and mice. The module is capable of both host-to-device and device-to-host communication.

23.3 Product Dependencies

23.3.1 I/O Lines

The PS/2 may be multiplexed with PIO lines. The programmer must first program the PIO controller to give control of the pins to the PS/2 module.

23.3.2 Power Management

The clock for the PS/2 module is generated by the power manager. The programmer must ensure that the PS/2 clock is enabled in the power manager before using the PS/2 module.

23.3.3 Interrupt

The PS/2 module has an interrupt line connected to the interrupt controller. Handling the PS/2 interrupt requires programming the interrupt controller before configuring the PS/2 module.

23.4 The PS/2 Protocol

The PS/2 protocol is a bidirectional synchronous serial communication protocol. It connects a single master - referred to as the 'host' - to a single slave - referred to as the 'device'. Communication is done through two lines called 'data' and 'clock'. Both of these must be open-drain or open-collector with a pullup resistor to perform a wired-AND function. When the bus is idle, both lines are high.

The device always generates the clock signal, but the host may pull the clock low to inhibit transfers. The clock frequency is in the range 10-16.7 kHz. Both the host and the slave may initiate a transfer, but the host has ultimate control of the bus.

Data are transmitted one byte at a time in a frame consisting of 11-12 bits. The transfer format is described in detail below.

23.4.1 Device to host communication

The device can only initiate a transfer when the bus is idle. If the host at any time pulls the clock low, the device must stop transferring data and prepare to receive data from the host.

The device transmits data using a 11-bit frame. The device writes a bit on the data line when the clock is high, and the host reads the bit when the clock is low.

The format of the frame is:

- 1 start bit - always 0.
- 8 data bits, least significant bit first.
- 1 parity bit - odd parity.
- 1 stop bit - always 1.

Figure 23-1. Device to host transfer

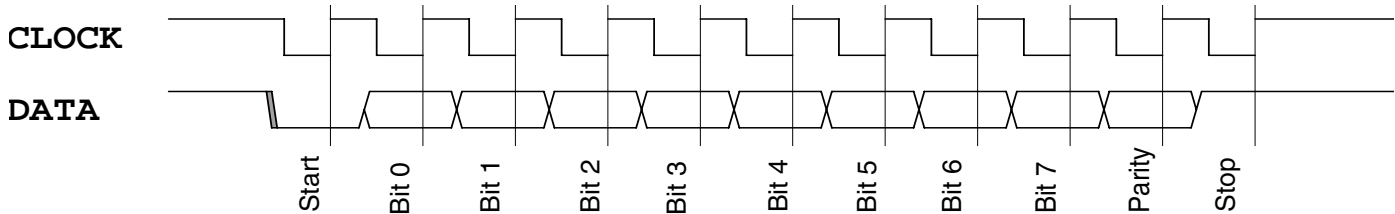

23.4.2 Host to device communication

Because the device always generates the clock, host to device communication is done differently than device to host communication.

- The host starts by inhibiting communication by pulling clock low for a minimum of 100 microseconds.
- Then applies a “request-to-send” by releasing clock and pulling data low.

The device must check for this state at least every 10 milliseconds. Once it detects a request-to-send, it must start generating the clock and receive one frame of data. The host writes a data bit when the clock is low, and the device reads the bit when the clock is high.

The format of the frame is:

- 1 start bit - always 0.
- 8 data bits - least significant bit first.
- 1 parity bit - odd parity
- 1 stop bit - always one.
- 1 acknowledge bit - the device acknowledges by pulling data low.

Figure 23-2. Host to device transfer

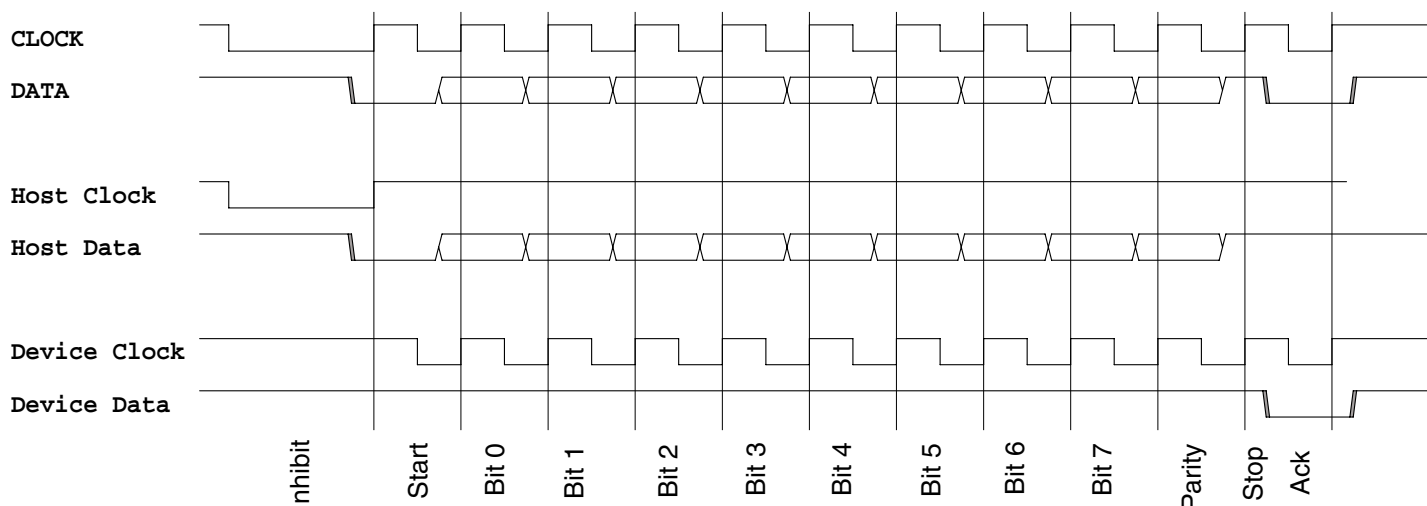

23.5 Functional Description

23.5.1 Prescaler

For all data transfers on the PS/2 bus, the device is responsible for generating the clock and thus controlling the timing of the communications. When a host wants to initiate a transfer however, it needs to pull the clock line low for a given time (minimum 100µs). A clock prescaler controls the timing of the transfer request pulse.

Before initiating host to device transfers, the programmer must write PSR (Prescale Register). This value determines the length of the “transfer request” pulse and is found by:

$$PRSCV = \text{Pulse length} * \text{PS/2 module frequency}$$

According to the PS/2 specifications, the pulse length should be at least 100µs. The PS/2 module frequency is the frequency of the peripheral bus to which the module is connected.

23.5.2 Receiving data

The receiver is enabled by writing the RXEN bit in CR (Control Register) to ‘1’. When enabled, the receiver will continuously receive data transmitted by the device. The data is stored in RHR (Receive Holding Register). When a byte has been received, the RXRDY bit in SR (Status Register) is set.

For each received byte, the parity is calculated. If it doesn’t match the parity bit received from the device, the PARITY bit in SR is set. The received byte should then be discarded.

If a received byte in RHR is not read before a new byte has been received, the overrun bit - OVRUN in SR is set. The new data is stored in RHR overwriting the previously received byte.

23.5.3 Transmitting data

The transmitter is enabled by writing the TXEN bit in CR to ‘1’. When enabled, a data transfer to the device will be started by writing the transmit data to THR (Transmit Holding Register). Any ongoing transfer from the device will be aborted.

When the data written to THR has been transmitted to the device, the TXRDY bit in SR will be set and a new value can be loaded into THR.

At the end of the transfer, the device should acknowledge the transfer by pulling the data line low for one cycle. If an acknowledge is not detected, the NACK bit in SR will be set.

If the device fails to acknowledge the frame, the NACK bit in SR will be set. The software is responsible for any retries.

All transfers from host to device are started by the host pulling the clock line low for at least 100µs. The programmer must ensure that the prescaler is programmed to generate correct pulse length.

23.5.4 Interrupts

The PS/2 module can be configured to signal an interrupt when one of the bits in SR is set. The interrupt is enabled by writing to IER (Interrupt Enable Register) and disabled by writing to IDR (Interrupt Disable Register). The current setting of an interrupt line can be seen by reading IMR (Interrupt Mask Register).

23.6 User Interface

Offset	Register	Register Name	Access	Reset
0x000	PS/2 Control Register 0	CR0	Write-only	-
0x004	PS/2 Receive Holding Register 0	RHR0	Read-only	0x0
0x008	PS/2 Transmit Holding Register 0	THR0	Write-only	-
0x00C	RESERVED	-	-	-
0x010	PS/2 Status Register 0	SR0	Read-only	0x0
0x014	PS/2 Interrupt Enable Register 0	IER0	Write-only	-
0x018	PS/2 Interrupt Disable Register 0	IDR0	Write-only	-
0x01C	PS/2 Interrupt Mask Register 0	IMR0	Read-only	0x0
0x020	PS/2 Prescale Register 0	PSR0	Write-only	0x0
0x100	PS/2 Control Register 1	CR1	Write-only	-
0x104	PS/2 Receive Holding Register 1	RHR1	Read-only	0x0
0x108	PS/2 Transmit Holding Register 1	THR1	Write-only	-
0x10C	RESERVED	-	-	-
0x110	PS/2 Status Register 1	SR1	Read-only	0x0
0x114	PS/2 Interrupt Enable Register 1	IER1	Write-only	-
0x118	PS/2 Interrupt Disable Register 1	IDR1	Write-only	-
0x11C	PS/2 Interrupt Mask Register 1	IMR1	Read-only	0x0
0x120	PS/2 Prescale Register 1	PSR1	Write-only	0x0

23.6.1 PS/2 Control Register

Name: CR0, CR1

Access Type: Write-only

31	30	29	28	27	26	25	24
-	-	-	-	-	-	-	-
23	22	21	20	19	18	17	16
-	-	-	-	-	-	-	-
15	14	13	12	11	10	9	8
SWRST	-	-	-	-	-	TXDIS	TXEN
7	6	5	4	3	2	1	0
-	-	-	-	-	-	RXDIS	RXEN

- **SWRST: Software Reset**

Writing this strobe causes a reset of the PS/2 interface module. Data shift registers are cleared and configuration registers are reset to default values.

- **TXDIS: Transmitter Disable**

0: No effect.
1: Disables the transmitter.

- **TXEN: Transmitter Enable**

0: No effect.
1: Enables the transmitter if TXDIS=0.

- **RXDIS: Receiver Disable**

0: No effect.
1: Disables the receiver.

- **RXEN: Receiver Enable**

0: No effect.
1: Enables the receiver if RXDIS=0.

23.6.2 PS/2 Receive Holding Register

Name: RHR0, RHR1

Access Type: Read-only

31	30	29	28	27	26	25	24
-	-	-	-	-	-	-	-
23	22	21	20	19	18	17	16
-	-	-	-	-	-	-	-
15	14	13	12	11	10	9	8
-	-	-	-	-	-	-	-
7	6	5	4	3	2	1	0
RXDATA							

• **RXDATA: Receive Data**

Data received from the device.

23.6.3 PS/2 Transmit Holding Register

Name: THR0, THR1

Access Type: Write-only

31	30	29	28	27	26	25	24
-	-	-	-	-	-	-	-
23	22	21	20	19	18	17	16
-	-	-	-	-	-	-	-
15	14	13	12	11	10	9	8
-	-	-	-	-	-	-	-
7	6	5	4	3	2	1	0
TXDATA							

• **TXDATA: Transmit Data**

- Data to be transmitted to the device.

23.6.4 PS/2 Status Register

Name: SR0, SR1

Access Type: Read-only

31	30	29	28	27	26	25	24
-	-	-	-	-	-	-	-
23	22	21	20	19	18	17	16
-	-	-	-	-	-	-	-
15	14	13	12	11	10	9	8
-	-	-	-	-	-	PARITY	NACK
7	6	5	4	3	2	1	0
-	-	OVRUN	RXRDY	-	-	TXEMPTY	TXRDY

- **PARITY:**

0: No parity errors detected on incoming data since last read of SR.

1: At least one parity error detected on incoming data since last read of SR.

- **NACK: Not Acknowledge**

0: All transmissions has been properly acknowledged by the device since last read of SR.

1: At least one transmission was not properly acknowledged by the device since last read of SR.

- **OVRUN: Overrun**

0: No receive overrun has occurred since the last read of SR.

1: At least one receive overrun condition has occurred since the last read of SR.

- **RXRDY: Receiver Ready**

0: RHR is empty.

1: RHR contains valid data received from the device.

- **TXEMPTY: Transmitter Empty**

0: Data remains in THR or is currently being transmitted from the shift register.

1: Both THR and the shift register are empty.

- **TXRDY: Transmitter Ready**

0: Data has been loaded in THR and is waiting to be loaded into the shift register.

1: THR is empty.

23.6.5 PS/2 Interrupt Enable Register

Name: IER0, IER1

Access Type: Write-only

31	30	29	28	27	26	25	24
-	-	-	-	-	-	-	-
23	22	21	20	19	18	17	16
-	-	-	-	-	-	-	-
15	14	13	12	11	10	9	8
-	-	-	-	-	-	PARITY	NACK
7	6	5	4	3	2	1	0
-	-	OVRUN	RXRDY	-	-	TXEMPTY	TXRDY

- **PARITY:** PARITY Interrupt Enable
- **NACK:** Not Acknowledge Interrupt Enable
- **OVRUN:** Overrun Interrupt Enable
- **RXRDY:** Overrun Interrupt Enable
- **TXEMPTY:** Overrun Interrupt Enable
- **TXRDY:** Overrun Interrupt Enable
 - 0: No effect.
 - 1: Enables the corresponding interrupt.

23.6.6 PS/2 Interrupt Disable Register

Name: IDR0, IDR1

Access Type: Write-Only

31	30	29	28	27	26	25	24
-	-	-	-	-	-	-	-
23	22	21	20	19	18	17	16
-	-	-	-	-	-	-	-
15	14	13	12	11	10	9	8
-	-	-	-	-	-	PARITY	NACK
7	6	5	4	3	2	1	0
-	-	OVRUN	RXRDY	-	-	TXEMPTY	TXRDY

- **PARITY:** PARITY Interrupt Disable
- **NACK:** Not Acknowledge Interrupt Disable
- **OVRUN:** Overrun Interrupt Disable
- **RXRDY:** Overrun Interrupt Disable
- **TXEMPTY:** Overrun Interrupt Disable
- **TXRDY:** Overrun Interrupt Disable

0: No effect.

1: Disables the corresponding interrupt.

23.6.7 PS/2 Interrupt Mask Register

Name: IMR0, IMR1

Access Type: Read-only

31	30	29	28	27	26	25	24
-	-	-	-	-	-	-	-
23	22	21	20	19	18	17	16
-	-	-	-	-	-	-	-
15	14	13	12	11	10	9	8
-	-	-	-	-	-	PARITY	NACK
7	6	5	4	3	2	1	0
-	-	OVRUN	RXRDY	-	-	TXEMPTY	TXRDY

- **PARITY:** PARITY Interrupt Mask
- **NACK:** Not Acknowledge Interrupt Mask
- **OVRUN:** Overrun Interrupt Mask
- **RXRDY:** Overrun Interrupt Mask
- **TXEMPTY:** Overrun Interrupt Mask
- **TXRDY:** Overrun Interrupt Mask

0: The corresponding interrupt is disabled.

1: The corresponding interrupt is enabled.

23.6.8 PS/2 Prescale Register

Name: PSR0, PSR1

Access Type: Read/Write

31	30	29	28	27	26	25	24
-	-	-	-	-	-	-	-
23	22	21	20	19	18	17	16
-	-	-	-	-	-	-	-
15	14	13	12	11	10	9	8
-	-	-	PRSCV				
7	6	5	4	3	2	1	0
PRSCV							

- **PRSCV: Prescale Value**

24. Synchronous Serial Controller (SSC)

Rev: 2.2.0.0

24.1 Features

- Provides Serial Synchronous Communication Links Used in Audio and Telecom Applications
- Contains an Independent Receiver and Transmitter and a Common Clock Divider
- Interfaced with Two PDC Channels (DMA Access) to Reduce Processor Overhead
- Offers a Configurable Frame Sync and Data Length
- Receiver and Transmitter Can be Programmed to Start Automatically or on Detection of Different Events on the Frame Sync Signal
- Receiver and Transmitter Include a Data Signal, a Clock Signal and a Frame Synchronization Signal

24.2 Description

The Atmel Synchronous Serial Controller (SSC) provides a synchronous communication link with external devices. It supports many serial synchronous communication protocols generally used in audio and telecom applications such as I2S, Short Frame Sync, Long Frame Sync, etc.

The SSC contains an independent receiver and transmitter and a common clock divider. The receiver and the transmitter each interface with three signals: the TD/RD signal for data, the TK/RK signal for the clock and the TF/RF signal for the Frame Sync. The transfers can be programmed to start automatically or on different events detected on the Frame Sync signal.

The SSC's high-level of programmability and its two dedicated PDC channels of up to 32 bits permit a continuous high bit rate data transfer without processor intervention.

Featuring connection to two PDC channels, the SSC permits interfacing with low processor overhead to the following:

- CODEC's in master or slave mode
- DAC through dedicated serial interface, particularly I2S
- Magnetic card reader

24.3 Block Diagram

Figure 24-1. Block Diagram

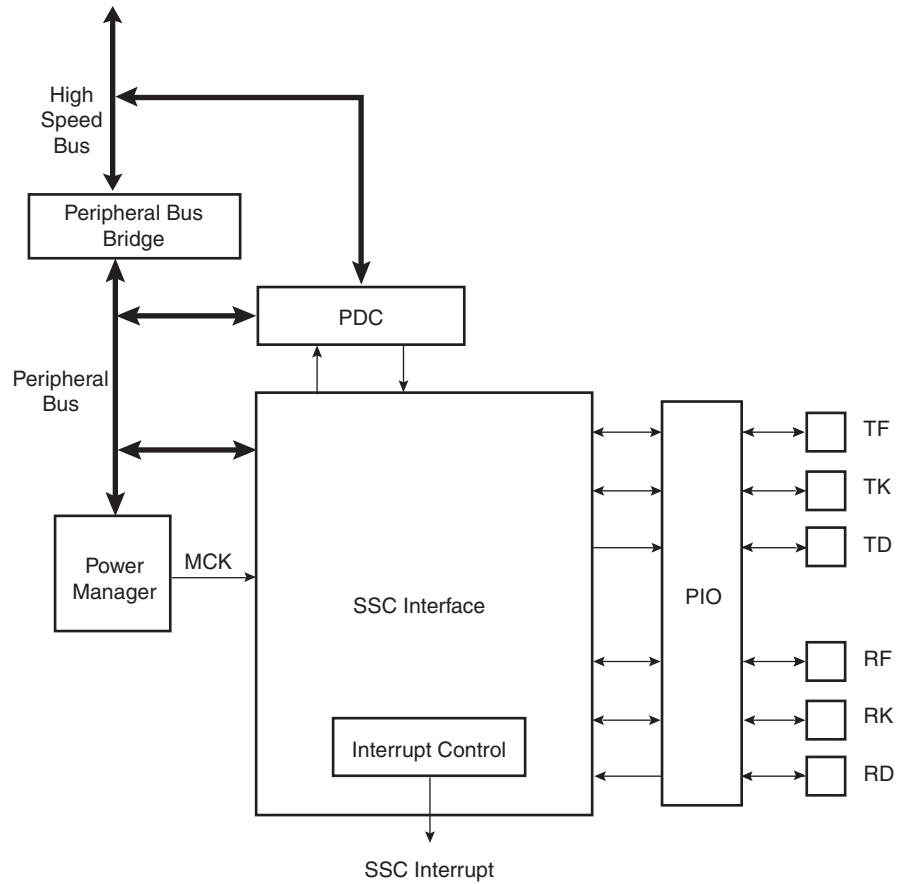

24.4 Application Block Diagram

Figure 24-2. Application Block Diagram

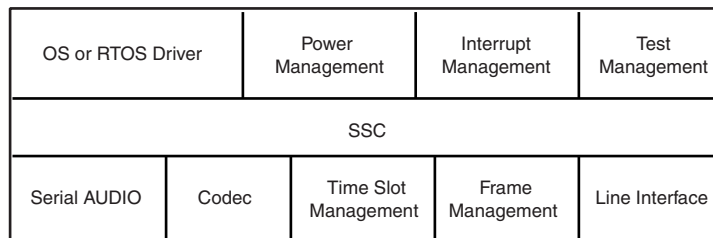

24.5 Pin Name List

Table 24-1. I/O Lines Description

Pin Name	Pin Description	Type
RF	Receiver Frame Synchro	Input/Output
RK	Receiver Clock	Input/Output
RD	Receiver Data	Input
TF	Transmitter Frame Synchro	Input/Output
TK	Transmitter Clock	Input/Output
TD	Transmitter Data	Output

24.6 Product Dependencies

24.6.1 I/O Lines

The pins used for interfacing the compliant external devices may be multiplexed with PIO lines.

Before using the SSC receiver, the PIO controller must be configured to dedicate the SSC receiver I/O lines to the SSC peripheral mode.

Before using the SSC transmitter, the PIO controller must be configured to dedicate the SSC transmitter I/O lines to the SSC peripheral mode.

24.6.2 Power Management

The SSC clock is generated by the power manager. Before using the SSC, the programmer must ensure that the SSC clock is enabled in the power manager.

In the SSC description, Master Clock (MCK) is the bus clock of the peripheral bus to which the SSC is connected.

24.6.3 Interrupt

The SSC interface has an interrupt line connected to the interrupt controller. Handling interrupts requires programming the interrupt controller before configuring the SSC.

All SSC interrupts can be enabled/disabled configuring the SSC Interrupt mask register. Each pending and unmasked SSC interrupt will assert the SSC interrupt line. The SSC interrupt service routine can get the interrupt origin by reading the SSC interrupt status register.

24.7 Functional Description

This chapter contains the functional description of the following: SSC Functional Block, Clock Management, Data format, Start, Transmitter, Receiver and Frame Sync.

The receiver and transmitter operate separately. However, they can work synchronously by programming the receiver to use the transmit clock and/or to start a data transfer when transmission starts. Alternatively, this can be done by programming the transmitter to use the receive clock and/or to start a data transfer when reception starts. The transmitter and the receiver can be programmed to operate with the clock signals provided on either the TK or RK pins. This allows the SSC to support many slave-mode data transfers. The maximum clock speed allowed on the TK and RK pins is the master clock divided by 2.

Figure 24-3. SSC Functional Block Diagram

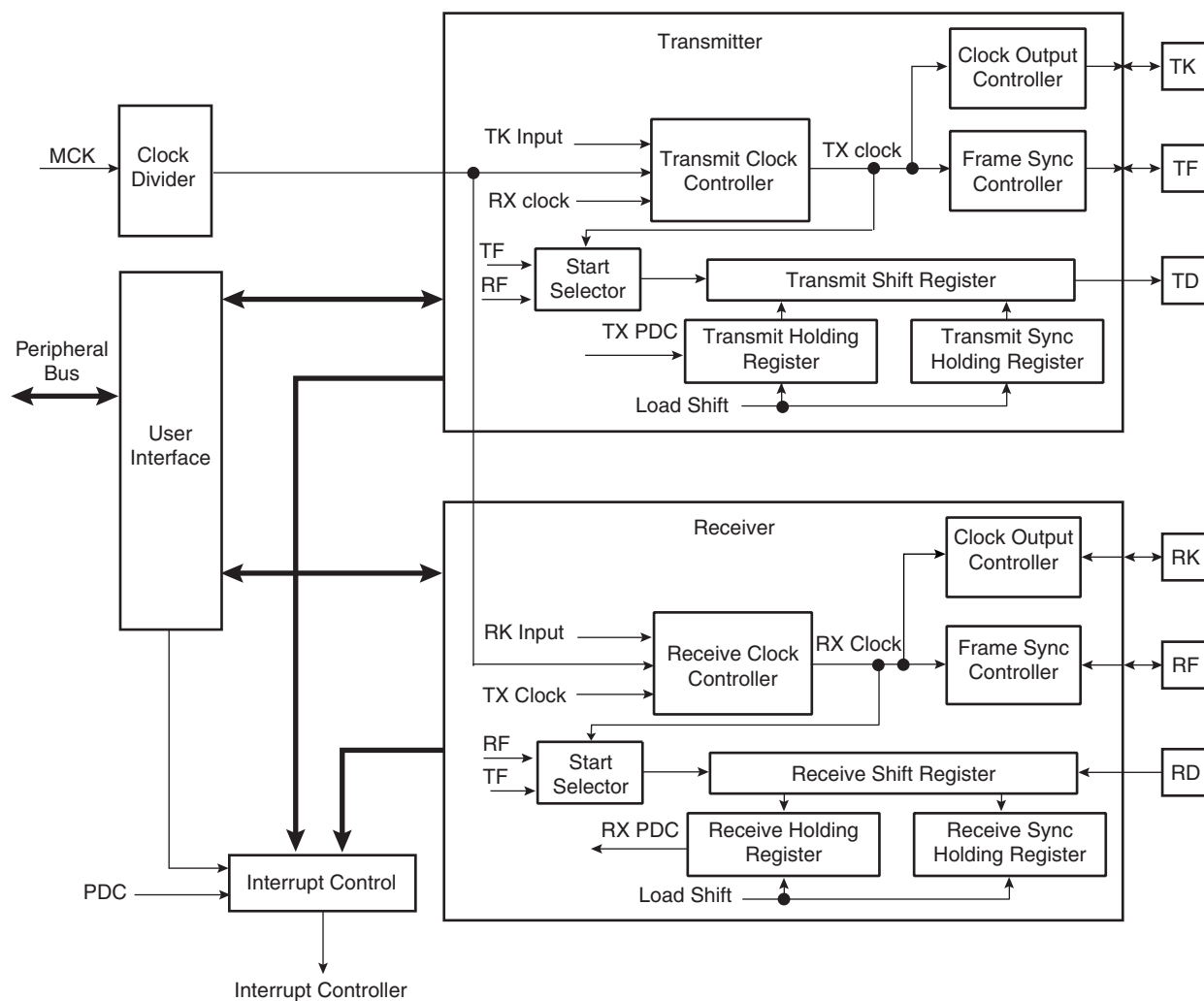

24.7.1 Clock Management

The transmitter clock can be generated by:

- an external clock received on the TK I/O pad
- the receiver clock
- the internal clock divider

The receiver clock can be generated by:

- an external clock received on the RK I/O pad
- the transmitter clock
- the internal clock divider

Furthermore, the transmitter block can generate an external clock on the TK I/O pad, and the receiver block can generate an external clock on the RK I/O pad.

This allows the SSC to support many Master and Slave Mode data transfers.

24.7.1.1 Clock Divider

Figure 24-4. Divided Clock Block Diagram

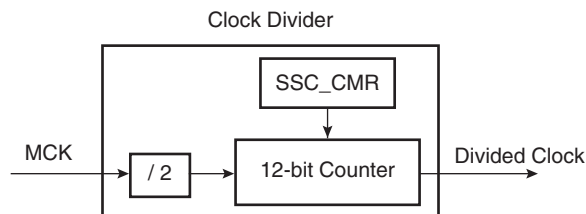

The Master Clock divider is determined by the 12-bit field DIV counter and comparator (so its maximal value is 4095) in the Clock Mode Register CMR, allowing a Master Clock division by up to 8190. The Divided Clock is provided to both the Receiver and Transmitter. When this field is programmed to 0, the Clock Divider is not used and remains inactive.

When DIV is set to a value equal to or greater than 1, the Divided Clock has a frequency of Master Clock divided by 2 times DIV. Each level of the Divided Clock has a duration of the Master Clock multiplied by DIV. This ensures a 50% duty cycle for the Divided Clock regardless of whether the DIV value is even or odd.

Figure 24-5. Divided Clock Generation

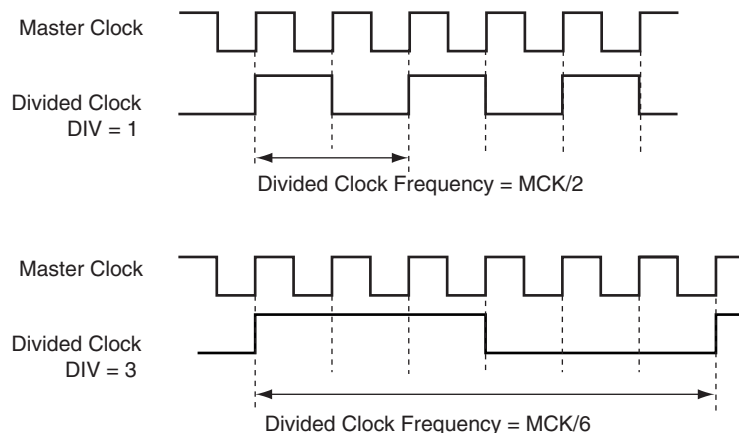

Table 24-2.

Maximum	Minimum
MCK / 2	MCK / 8190

24.7.1.2 Transmitter Clock Management

The transmitter clock is generated from the receiver clock or the divider clock or an external clock scanned on the TK I/O pad. The transmitter clock is selected by the CKS field in TCMR (Transmit Clock Mode Register). Transmit Clock can be inverted independently by the CKI bits in TCMR.

The transmitter can also drive the TK I/O pad continuously or be limited to the actual data transfer. The clock output is configured by the TCMR register. The Transmit Clock Inversion (CKI) bits have no effect on the clock outputs. Programming the TCMR register to select TK pin (CKS field) and at the same time Continuous Transmit Clock (CKO field) might lead to unpredictable results.

Figure 24-6. Transmitter Clock Management

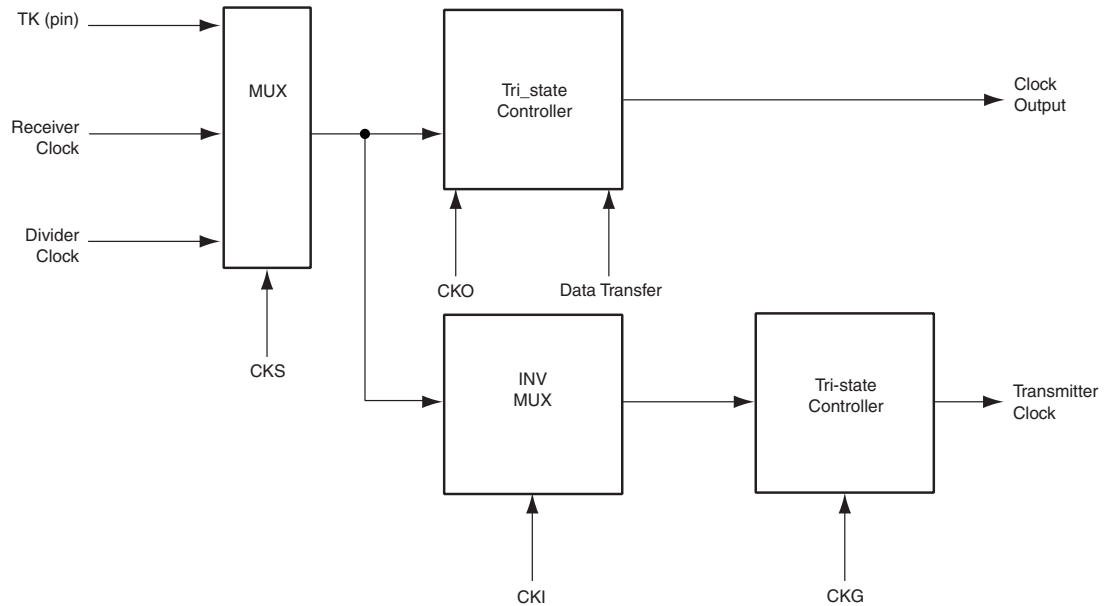

24.7.1.3 Receiver Clock Management

The receiver clock is generated from the transmitter clock or the divider clock or an external clock scanned on the RK I/O pad. The Receive Clock is selected by the CKS field in RCMR (Receive Clock Mode Register). Receive Clocks can be inverted independently by the CKI bits in RCMR.

The receiver can also drive the RK I/O pad continuously or be limited to the actual data transfer. The clock output is configured by the RCMR register. The Receive Clock Inversion (CKI) bits have no effect on the clock outputs. Programming the RCMR register to select RK pin (CKS field) and at the same time Continuous Receive Clock (CKO field) can lead to unpredictable results.

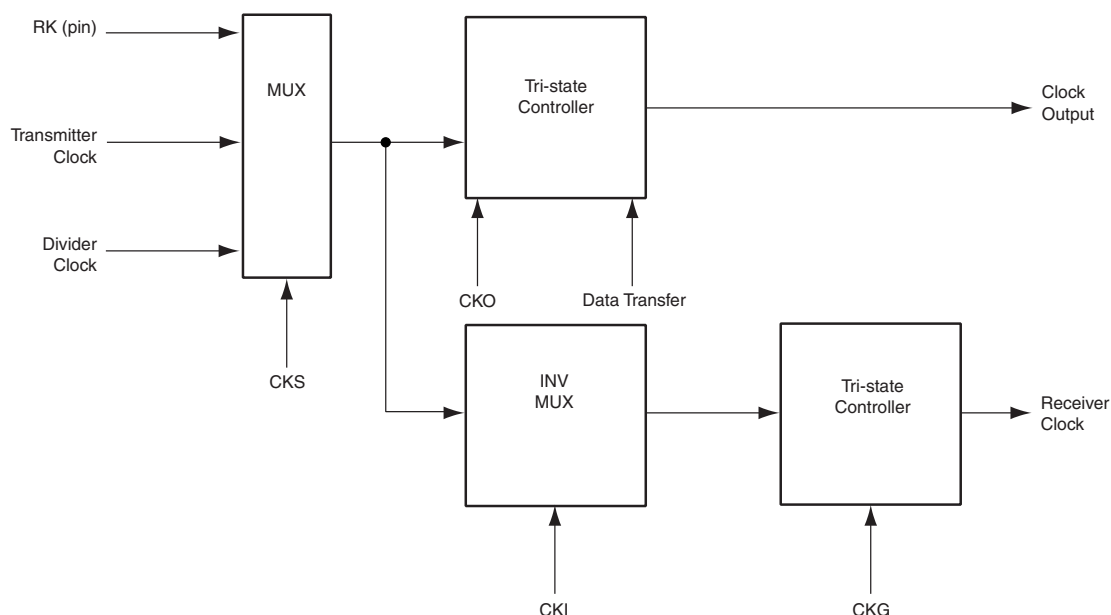
Figure 24-7. Receiver Clock Management

24.7.1.4 Serial Clock Ratio Considerations

The Transmitter and the Receiver can be programmed to operate with the clock signals provided on either the TK or RK pins. This allows the SSC to support many slave-mode data transfers. In this case, the maximum clock speed allowed on the RK pin is:

- Master Clock divided by 2 if Receiver Frame Synchro is input
- Master Clock divided by 3 if Receiver Frame Synchro is output

In addition, the maximum clock speed allowed on the TK pin is:

- Master Clock divided by 6 if Transmit Frame Synchro is input
- Master Clock divided by 2 if Transmit Frame Synchro is output

24.7.2 Transmitter Operations

A transmitted frame is triggered by a start event and can be followed by synchronization data before data transmission.

The start event is configured by setting the Transmit Clock Mode Register (TCMR). [See Section “24.7.4” on page 347.](#)

The frame synchronization is configured setting the Transmit Frame Mode Register (TFMR). [See Section “24.7.5” on page 349.](#)

To transmit data, the transmitter uses a shift register clocked by the transmitter clock signal and the start mode selected in the TCMR. Data is written by the application to the THR register then transferred to the shift register according to the data format selected.

When both the THR and the transmit shift register are empty, the status flag TXEMPTY is set in SR. When the Transmit Holding register is transferred in the Transmit shift register, the status flag TXRDY is set in SR and additional data can be loaded in the holding register.

Figure 24-8. Transmitter Block Diagram

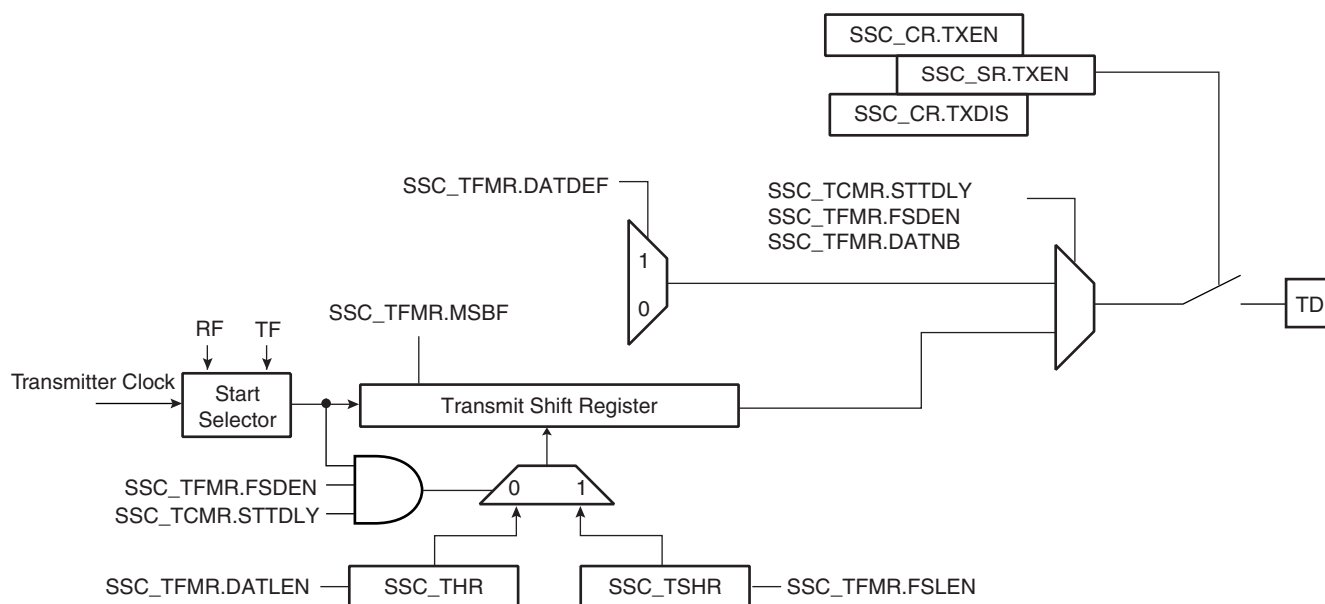

24.7.3 Receiver Operations

A received frame is triggered by a start event and can be followed by synchronization data before data transmission.

The start event is configured setting the Receive Clock Mode Register (RCMR). [See Section “24.7.4” on page 347.](#)

The frame synchronization is configured setting the Receive Frame Mode Register (RFMR). [See Section “24.7.5” on page 349.](#)

The receiver uses a shift register clocked by the receiver clock signal and the start mode selected in the RCMR. The data is transferred from the shift register depending on the data format selected.

When the receiver shift register is full, the SSC transfers this data in the holding register, the status flag RXRDY is set in SR and the data can be read in the receiver holding register. If another transfer occurs before read of the RHR register, the status flag OVERUN is set in SR and the receiver shift register is transferred in the RHR register.

Figure 24-9. Receiver Block Diagram

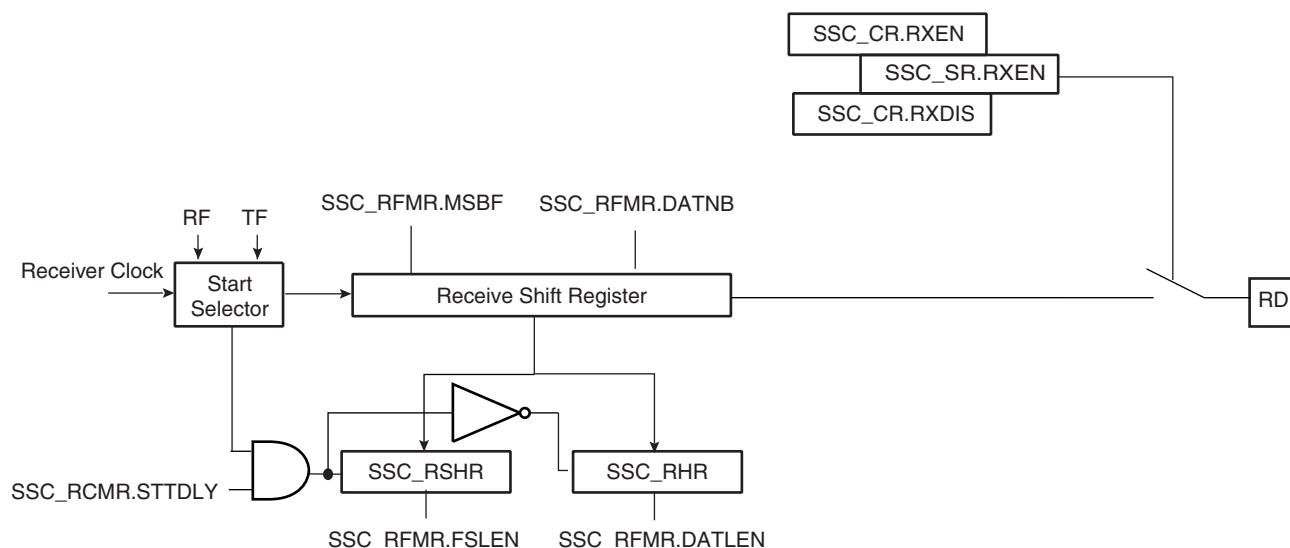

24.7.4 Start

The transmitter and receiver can both be programmed to start their operations when an event occurs, respectively in the Transmit Start Selection (START) field of TCMR and in the Receive Start Selection (START) field of RCMR.

Under the following conditions the start event is independently programmable:

- Continuous. In this case, the transmission starts as soon as a word is written in THR and the reception starts as soon as the Receiver is enabled.
- Synchronously with the transmitter/receiver
- On detection of a falling/rising edge on TF/RF
- On detection of a low level/high level on TF/RF
- On detection of a level change or an edge on TF/RF

A start can be programmed in the same manner on either side of the Transmit/Receive Clock Register (RCMR/TCMR). Thus, the start could be on TF (Transmit) or RF (Receive).

Moreover, the Receiver can start when data is detected in the bit stream with the Compare Functions.

Detection on TF/RF input/output is done by the field FSOS of the Transmit/Receive Frame Mode Register (TFMR/RFMR).

Figure 24-10. Transmit Start Mode

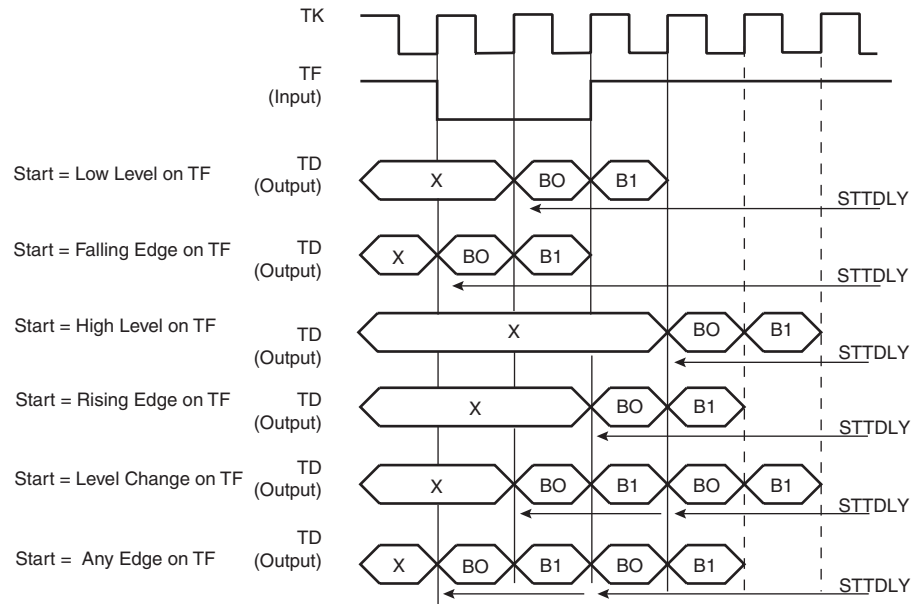
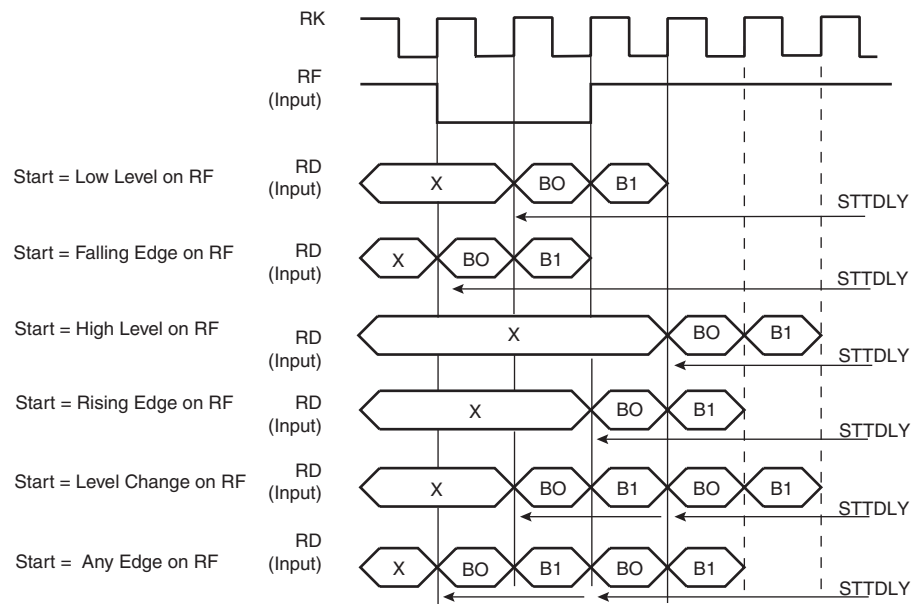

Figure 24-11. Receive Pulse/Edge Start Modes



24.7.5 Frame Sync

The Transmitter and Receiver Frame Sync pins, TF and RF, can be programmed to generate different kinds of frame synchronization signals. The Frame Sync Output Selection (FSOS) field in the Receive Frame Mode Register (RFMR) and in the Transmit Frame Mode Register (TFMR) are used to select the required waveform.

- Programmable low or high levels during data transfer are supported.
- Programmable high levels before the start of data transfers or toggling are also supported.

If a pulse waveform is selected, the Frame Sync Length (FSLEN) field in RFMR and TFMR programs the length of the pulse, from 1 bit time up to 16 bit time.

The periodicity of the Receive and Transmit Frame Sync pulse output can be programmed through the Period Divider Selection (PERIOD) field in RCMR and TCMR.

24.7.5.1 Frame Sync Data

Frame Sync Data transmits or receives a specific tag during the Frame Sync signal.

During the Frame Sync signal, the Receiver can sample the RD line and store the data in the Receive Sync Holding Register and the transmitter can transfer Transmit Sync Holding Register in the Shifter Register. The data length to be sampled/shifted out during the Frame Sync signal is programmed by the FSLEN field in RFMR/TFMR.

Concerning the Receive Frame Sync Data operation, if the Frame Sync Length is equal to or lower than the delay between the start event and the actual data reception, the data sampling operation is performed in the Receive Sync Holding Register through the Receive Shift Register.

The Transmit Frame Sync Operation is performed by the transmitter only if the bit Frame Sync Data Enable (FSDEN) in TFMR is set. If the Frame Sync length is equal to or lower than the delay between the start event and the actual data transmission, the normal transmission has priority and the data contained in the Transmit Sync Holding Register is transferred in the Transmit Register, then shifted out.

24.7.5.2 Frame Sync Edge Detection

The Frame Sync Edge detection is programmed by the FSEDGE field in RFMR/TFMR. This sets the corresponding flags RXSYN/TXSYN in the SSC Status Register (SR) on frame synchro edge detection (signals RF/TF).

24.7.6 Receive Compare Modes

Figure 24-12. Receive Compare Modes

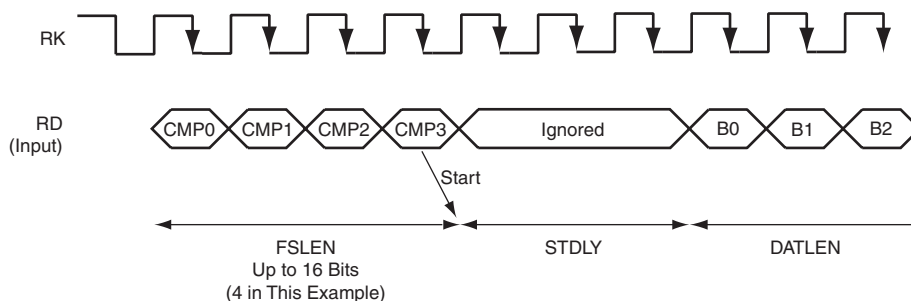

24.7.6.1 Compare Functions

Compare 0 can be one start event of the Receiver. In this case, the receiver compares at each new sample the last FSLEN bits received at the FSLEN lower bit of the data contained in the Compare 0 Register (RC0R). When this start event is selected, the user can program the Receiver to start a new data transfer either by writing a new Compare 0, or by receiving continuously until Compare 1 occurs. This selection is done with the bit (STOP) in RCMR.

24.7.7 Data Format

The data framing format of both the transmitter and the receiver are programmable through the Transmitter Frame Mode Register (TFMR) and the Receiver Frame Mode Register (RFMR). In either case, the user can independently select:

- the event that starts the data transfer (START)
- the delay in number of bit periods between the start event and the first data bit (STTDLY)
- the length of the data (DATLEN)
- the number of data to be transferred for each start event (DATNB).
- the length of synchronization transferred for each start event (FSLEN)
- the bit sense: most or lowest significant bit first (MSBF).

Additionally, the transmitter can be used to transfer synchronization and select the level driven on the TD pin while not in data transfer operation. This is done respectively by the Frame Sync Data Enable (FSDEN) and by the Data Default Value (DATDEF) bits in TFMR.

Table 24-3. Data Frame Registers

Transmitter	Receiver	Field	Length	Comment
TFMR	RFMR	DATLEN	Up to 32	Size of word
TFMR	RFMR	DATNB	Up to 16	Number of words transmitted in frame
TFMR	RFMR	MSBF		Most significant bit first
TFMR	RFMR	FSLEN	Up to 16	Size of Synchro data register
TFMR		DATDEF	0 or 1	Data default value ended
TFMR		FSDEN		Enable send TSHR
TCMR	RCMR	PERIOD	Up to 512	Frame size
TCMR	RCMR	STTDLY	Up to 255	Size of transmit start delay

Figure 24-13. Transmit and Receive Frame Format in Edge/Pulse Start Modes

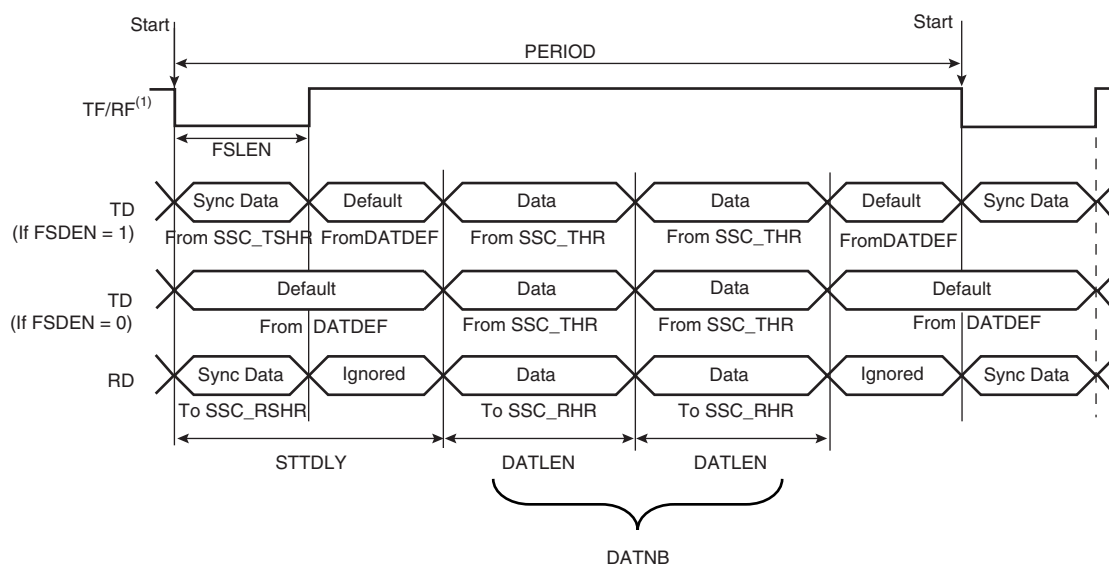

Note: 1. Example of input on falling edge of TF/RF.

Figure 24-14. Transmit Frame Format in Continuous Mode

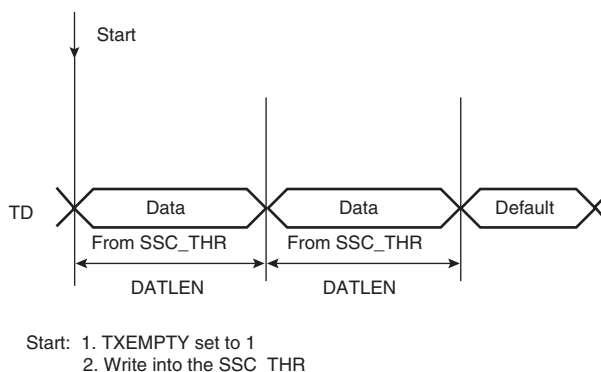

Note: 1. STTDLY is set to 0. In this example, THR is loaded twice. FSDEN value has no effect on the transmission. SyncData cannot be output in continuous mode.

Figure 24-15. Receive Frame Format in Continuous Mode

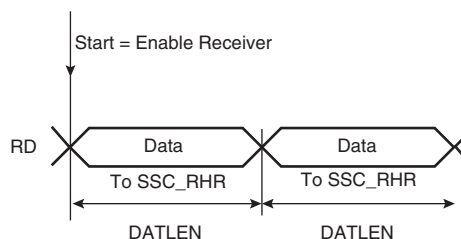

Note: 1. STTDLY is set to 0.

24.7.8 Loop Mode

The receiver can be programmed to receive transmissions from the transmitter. This is done by setting the Loop Mode (LOOP) bit in RFMR. In this case, RD is connected to TD, RF is connected to TF and RK is connected to TK.

24.7.9 Interrupt

Most bits in SR have a corresponding bit in interrupt management registers.

The SSC can be programmed to generate an interrupt when it detects an event. The interrupt is controlled by writing IER (Interrupt Enable Register) and IDR (Interrupt Disable Register) These registers enable and disable, respectively, the corresponding interrupt by setting and clearing the corresponding bit in IMR (Interrupt Mask Register), which controls the generation of interrupts by asserting the SSC interrupt line connected to the interrupt controller.

Figure 24-16. Interrupt Block Diagram

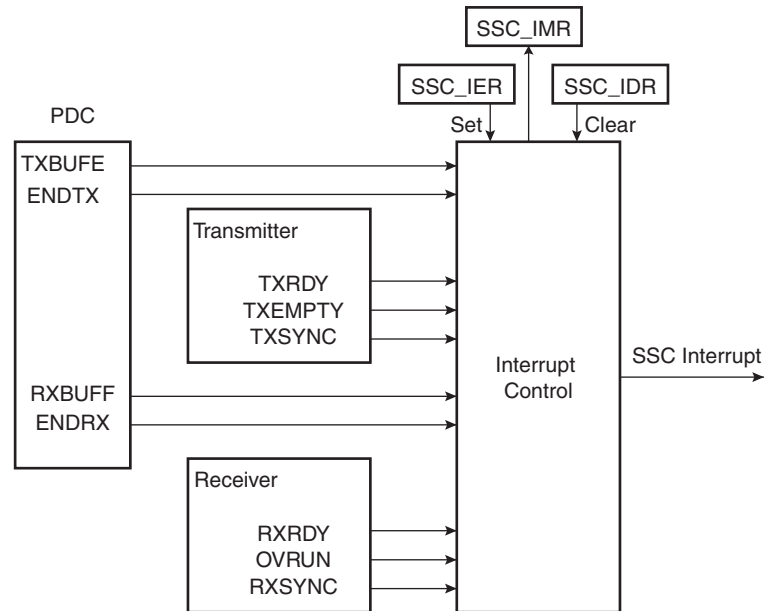

24.8 SSC Application Examples

The SSC can support several serial communication modes used in audio or high speed serial links. Some standard applications are shown in the following figures. All serial link applications supported by the SSC are not listed here.

Figure 24-17. Audio Application Block Diagram

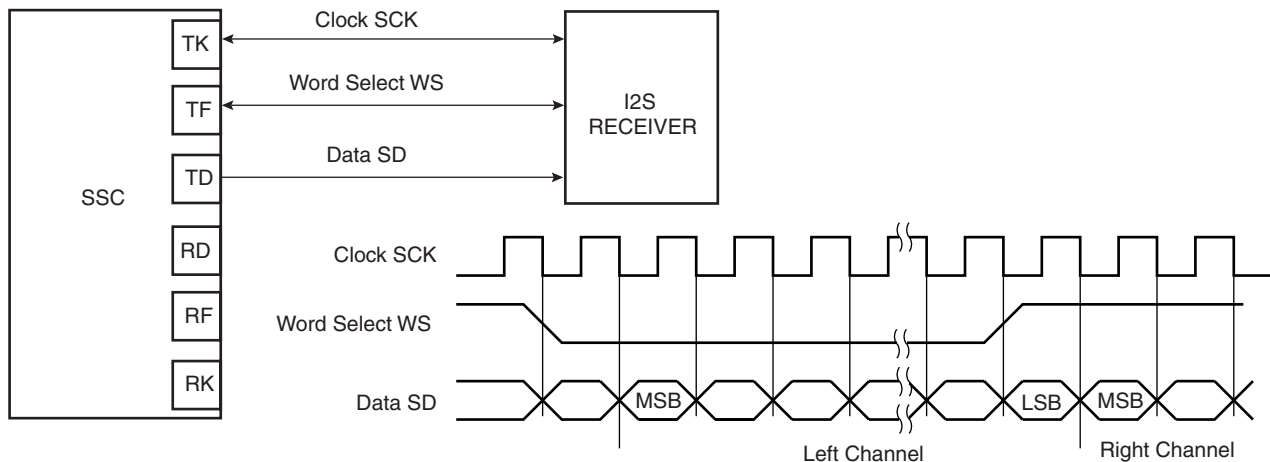

Figure 24-18. Codec Application Block Diagram

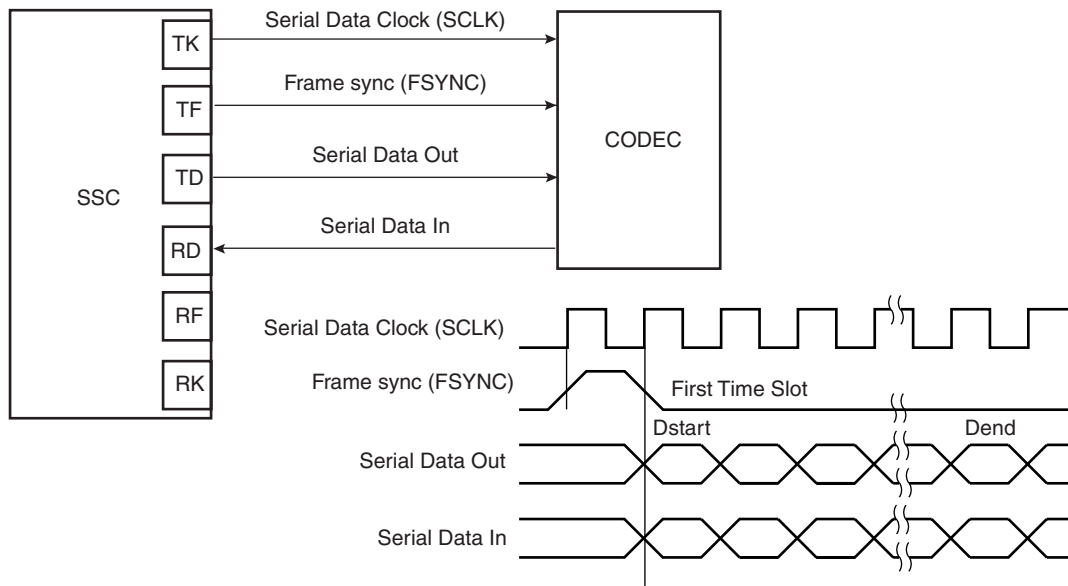
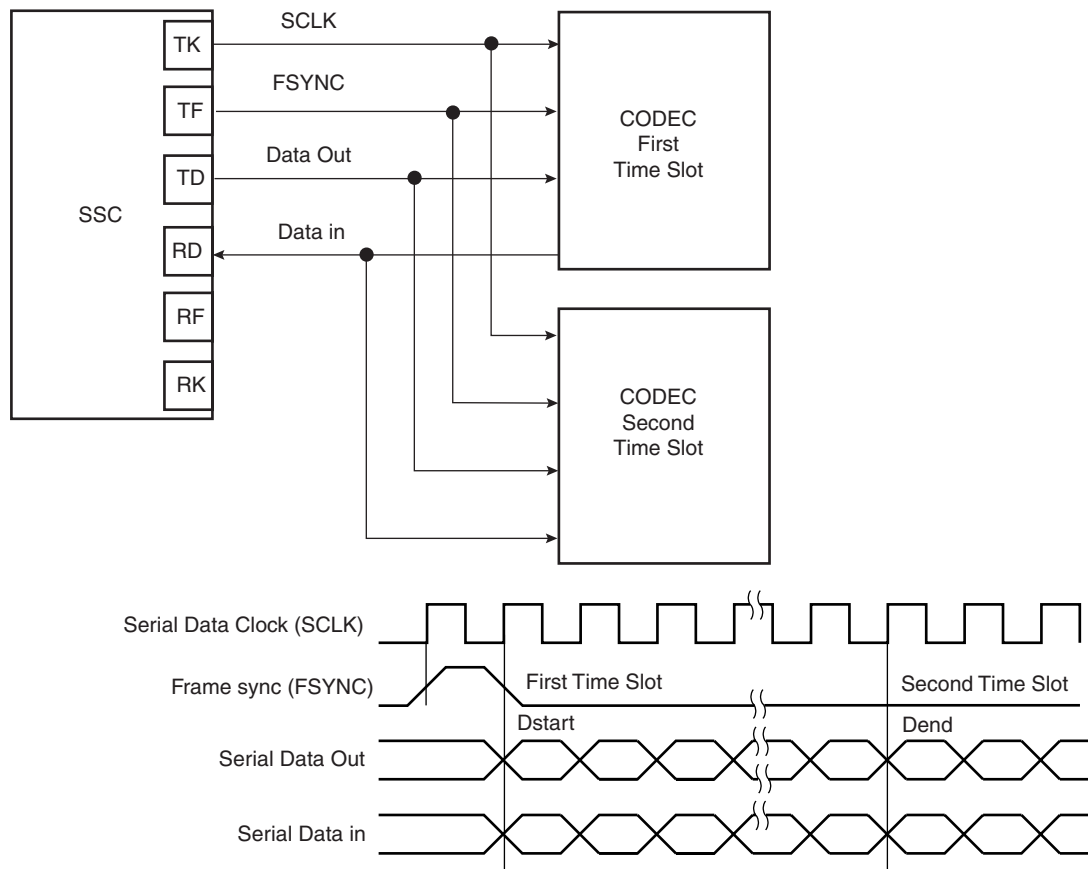

Figure 24-19. Time Slot Application Block Diagram



24.9 Synchronous Serial Controller (SSC) User Interface

Table 24-4. Register Mapping

Offset	Register	Register Name	Access	Reset
0x0	Control Register	CR	Write	–
0x4	Clock Mode Register	CMR	Read/Write	0x0
0x8	Reserved	–	–	–
0xC	Reserved	–	–	–
0x10	Receive Clock Mode Register	RCMR	Read/Write	0x0
0x14	Receive Frame Mode Register	RFMR	Read/Write	0x0
0x18	Transmit Clock Mode Register	TCMR	Read/Write	0x0
0x1C	Transmit Frame Mode Register	TFMR	Read/Write	0x0
0x20	Receive Holding Register	RHR	Read	0x0
0x24	Transmit Holding Register	THR	Write	–
0x28	Reserved	–	–	–
0x2C	Reserved	–	–	–
0x30	Receive Sync. Holding Register	RSHR	Read	0x0
0x34	Transmit Sync. Holding Register	TSHR	Read/Write	0x0
0x38	Receive Compare 0 Register	RC0R	Read/Write	0x0
0x3C	Receive Compare 1 Register	RC1R	Read/Write	0x0
0x40	Status Register	SR	Read	0x000000CC
0x44	Interrupt Enable Register	IER	Write	–
0x48	Interrupt Disable Register	IDR	Write	–
0x4C	Interrupt Mask Register	IMR	Read	0x0
0x50-0xFC	Reserved	–	–	–
0x100- 0x124	Reserved for Peripheral Data Controller (PDC)	–	–	–

24.9.1 SSC Control Register

Name: CR

Access Type: Write-only

31	30	29	28	27	26	25	24
–	–	–	–	–	–	–	–
23	22	21	20	19	18	17	16
–	–	–	–	–	–	–	–
15	14	13	12	11	10	9	8
SWRST	–	–	–	–	–	TXDIS	TXEN
7	6	5	4	3	2	1	0
–	–	–	–	–	–	RXDIS	RXEN

- **RXEN: Receive Enable**

0: No effect.

1: Enables Receive if RXDIS is not set.

- **RXDIS: Receive Disable**

0: No effect.

1: Disables Receive. If a character is currently being received, disables at end of current character reception.

- **TXEN: Transmit Enable**

0: No effect.

1: Enables Transmit if TXDIS is not set.

- **TXDIS: Transmit Disable**

0: No effect.

1: Disables Transmit. If a character is currently being transmitted, disables at end of current character transmission.

- **SWRST: Software Reset**

0: No effect.

1: Performs a software reset. Has priority on any other bit in CR.

24.9.2 SSC Clock Mode Register

Name: CMR

Access Type: Read/Write

31	30	29	28	27	26	25	24
-	-	-	-	-	-	-	-
23	22	21	20	19	18	17	16
-	-	-	-	-	-	-	-
15	14	13	12	11	10	9	8
-	-	-	-	DIV			
7	6	5	4	3	2	1	0
DIV							

- **DIV: Clock Divider**

0: The Clock Divider is not active.

Any Other Value: The Divided Clock equals the Master Clock divided by 2 times DIV. The maximum bit rate is $MCK/2$. The minimum bit rate is $MCK/2 \times 4095 = MCK/8190$.

24.9.3 SSC Receive Clock Mode Register

Name: RCMR

Access Type: Read/Write

31	30	29	28	27	26	25	24
PERIOD							
23	22	21	20	19	18	17	16
STTDLY							
15	14	13	12	11	10	9	8
-	-	-	STOP	START			
7	6	5	4	3	2	1	0
CKG		CKI	CKO			CKS	

• CKS: Receive Clock Selection

CKS	Selected Receive Clock
0x0	Divided Clock
0x1	TK Clock signal
0x2	RK pin
0x3	Reserved

• CKO: Receive Clock Output Mode Selection

CKO	Receive Clock Output Mode	RK pin
0x0	None	Input-only
0x1	Continuous Receive Clock	Output
0x2	Receive Clock only during data transfers	Output
0x3-0x7	Reserved	

• CKI: Receive Clock Inversion

0: The data inputs (Data and Frame Sync signals) are sampled on Receive Clock falling edge. The Frame Sync signal output is shifted out on Receive Clock rising edge.

1: The data inputs (Data and Frame Sync signals) are sampled on Receive Clock rising edge. The Frame Sync signal output is shifted out on Receive Clock falling edge.

CKI affects only the Receive Clock and not the output clock signal.

• **CKG: Receive Clock Gating Selection**

CKG	Receive Clock Gating
0x0	None, continuous clock
0x1	Receive Clock enabled only if RF Low
0x2	Receive Clock enabled only if RF High
0x3	Reserved

• **START: Receive Start Selection**

START	Receive Start
0x0	Continuous, as soon as the receiver is enabled, and immediately after the end of transfer of the previous data.
0x1	Transmit start
0x2	Detection of a low level on RF signal
0x3	Detection of a high level on RF signal
0x4	Detection of a falling edge on RF signal
0x5	Detection of a rising edge on RF signal
0x6	Detection of any level change on RF signal
0x7	Detection of any edge on RF signal
0x8	Compare 0
0x9-0xF	Reserved

• **STOP: Receive Stop Selection**

0: After completion of a data transfer when starting with a Compare 0, the receiver stops the data transfer and waits for a new compare 0.

1: After starting a receive with a Compare 0, the receiver operates in a continuous mode until a Compare 1 is detected.

• **STTDLY: Receive Start Delay**

If STTDLY is not 0, a delay of STTDLY clock cycles is inserted between the start event and the actual start of reception. When the Receiver is programmed to start synchronously with the Transmitter, the delay is also applied.

Note: It is very important that STTDLY be set carefully. If STTDLY must be set, it should be done in relation to TAG (Receive Sync Data) reception.

• **PERIOD: Receive Period Divider Selection**

This field selects the divider to apply to the selected Receive Clock in order to generate a new Frame Sync Signal. If 0, no PERIOD signal is generated. If not 0, a PERIOD signal is generated each 2 x (PERIOD+1) Receive Clock.

24.9.4 SSC Receive Frame Mode Register

Name: RFMR

Access Type: Read/Write

31	30	29	28	27	26	25	24
-	-	-	-	-	-	-	FSEDGE
23	22	21	20	19	18	17	16
-	FSOS			FSLEN			
15	14	13	12	11	10	9	8
-	-	-	-	DATNB			
7	6	5	4	3	2	1	0
MSBF	-	LOOP	DATLEN				

- **DATLEN: Data Length**

0: Forbidden value (1-bit data length not supported).

Any other value: The bit stream contains DATLEN + 1 data bits. Moreover, it defines the transfer size performed by the PDC2 assigned to the Receiver. If DATLEN is lower or equal to 7, data transfers are in bytes. If DATLEN is between 8 and 15 (included), half-words are transferred, and for any other value, 32-bit words are transferred.

- **LOOP: Loop Mode**

0: Normal operating mode.

1: RD is driven by TD, RF is driven by TF and TK drives RK.

- **MSBF: Most Significant Bit First**

0: The lowest significant bit of the data register is sampled first in the bit stream.

1: The most significant bit of the data register is sampled first in the bit stream.

- **DATNB: Data Number per Frame**

This field defines the number of data words to be received after each transfer start, which is equal to (DATNB + 1).

- **FSLEN: Receive Frame Sync Length**

This field defines the length of the Receive Frame Sync Signal and the number of bits sampled and stored in the Receive Sync Data Register. When this mode is selected by the START field in the Receive Clock Mode Register, it also determines the length of the sampled data to be compared to the Compare 0 or Compare 1 register.

Pulse length is equal to (FSLEN + 1) Receive Clock periods. Thus, if FSLEN is 0, the Receive Frame Sync signal is generated during one Receive Clock period.

- **FSOS: Receive Frame Sync Output Selection**

FSOS	Selected Receive Frame Sync Signal	RF Pin
0x0	None	Input-only
0x1	Negative Pulse	Output
0x2	Positive Pulse	Output
0x3	Driven Low during data transfer	Output
0x4	Driven High during data transfer	Output
0x5	Toggling at each start of data transfer	Output
0x6-0x7	Reserved	Undefined

- **FSEDGE: Frame Sync Edge Detection**

Determines which edge on Frame Sync will generate the interrupt RXSYN in the SSC Status Register.

FSEDGE	Frame Sync Edge Detection
0x0	Positive Edge Detection
0x1	Negative Edge Detection

24.9.5 SSC Transmit Clock Mode Register

Name: TCMR

Access Type: Read/Write

31	30	29	28	27	26	25	24
PERIOD							
23	22	21	20	19	18	17	16
STTDLY							
15	14	13	12	11	10	9	8
-	-	-	-	START			
7	6	5	4	3	2	1	0
CKG		CKI	CKO			CKS	

• CKS: Transmit Clock Selection

CKS	Selected Transmit Clock
0x0	Divided Clock
0x1	RK Clock signal
0x2	TK Pin
0x3	Reserved

• CKO: Transmit Clock Output Mode Selection

CKO	Transmit Clock Output Mode	TK pin
0x0	None	Input-only
0x1	Continuous Transmit Clock	Output
0x2	Transmit Clock only during data transfers	Output
0x3-0x7	Reserved	

• CKI: Transmit Clock Inversion

0: The data outputs (Data and Frame Sync signals) are shifted out on Transmit Clock falling edge. The Frame sync signal input is sampled on Transmit clock rising edge.

1: The data outputs (Data and Frame Sync signals) are shifted out on Transmit Clock rising edge. The Frame sync signal input is sampled on Transmit clock falling edge.

CKI affects only the Transmit Clock and not the output clock signal.

- **CKG: Transmit Clock Gating Selection**

CKG	Transmit Clock Gating
0x0	None, continuous clock
0x1	Transmit Clock enabled only if TF Low
0x2	Transmit Clock enabled only if TF High
0x3	Reserved

- **START: Transmit Start Selection**

START	Transmit Start
0x0	Continuous, as soon as a word is written in the THR Register (if Transmit is enabled), and immediately after the end of transfer of the previous data.
0x1	Receive start
0x2	Detection of a low level on TF signal
0x3	Detection of a high level on TF signal
0x4	Detection of a falling edge on TF signal
0x5	Detection of a rising edge on TF signal
0x6	Detection of any level change on TF signal
0x7	Detection of any edge on TF signal
0x8 - 0xF	Reserved

- **STTDLY: Transmit Start Delay**

If STTDLY is not 0, a delay of STTDLY clock cycles is inserted between the start event and the actual start of transmission of data. When the Transmitter is programmed to start synchronously with the Receiver, the delay is also applied.

Note: STTDLY must be set carefully. If STTDLY is too short in respect to TAG (Transmit Sync Data) emission, data is emitted instead of the end of TAG.

- **PERIOD: Transmit Period Divider Selection**

This field selects the divider to apply to the selected Transmit Clock to generate a new Frame Sync Signal. If 0, no period signal is generated. If not 0, a period signal is generated at each $2 \times (\text{PERIOD} + 1)$ Transmit Clock.

24.9.6 SSC Transmit Frame Mode Register

Name: TFMR

Access Type: Read/Write

31	30	29	28	27	26	25	24
-	-	-	-	-	-	-	FSEDGE
23	22	21	20	19	18	17	16
FSDEN	FSOS			FSLEN			
15	14	13	12	11	10	9	8
-	-	-	-	DATNB			
7	6	5	4	3	2	1	0
MSBF	-	DATDEF	DATLEN				

- **DATLEN: Data Length**

0: Forbidden value (1-bit data length not supported).

Any other value: The bit stream contains DATLEN + 1 data bits. Moreover, it defines the transfer size performed by the PDC2 assigned to the Transmit. If DATLEN is lower or equal to 7, data transfers are bytes, if DATLEN is between 8 and 15 (included), half-words are transferred, and for any other value, 32-bit words are transferred.

- **DATDEF: Data Default Value**

This bit defines the level driven on the TD pin while out of transmission. Note that if the pin is defined as multi-drive by the PIO Controller, the pin is enabled only if the SCC TD output is 1.

- **MSBF: Most Significant Bit First**

0: The lowest significant bit of the data register is shifted out first in the bit stream.

1: The most significant bit of the data register is shifted out first in the bit stream.

- **DATNB: Data Number per frame**

This field defines the number of data words to be transferred after each transfer start, which is equal to (DATNB + 1).

- **FSLEN: Transmit Frame Sync Length**

This field defines the length of the Transmit Frame Sync signal and the number of bits shifted out from the Transmit Sync Data Register if FSDEN is 1.

Pulse length is equal to (FSLEN + 1) Transmit Clock periods, i.e., the pulse length can range from 1 to 16 Transmit Clock periods. If FSLEN is 0, the Transmit Frame Sync signal is generated during one Transmit Clock period.

- **FSOS: Transmit Frame Sync Output Selection**

FSOS	Selected Transmit Frame Sync Signal	TF Pin
0x0	None	Input-only
0x1	Negative Pulse	Output
0x2	Positive Pulse	Output
0x3	Driven Low during data transfer	Output
0x4	Driven High during data transfer	Output
0x5	Toggling at each start of data transfer	Output
0x6-0x7	Reserved	Undefined

- **FSDEN: Frame Sync Data Enable**

0: The TD line is driven with the default value during the Transmit Frame Sync signal.

1: TSHR value is shifted out during the transmission of the Transmit Frame Sync signal.

- **FSEDGE: Frame Sync Edge Detection**

Determines which edge on frame sync will generate the interrupt TXSYN (Status Register).

FSEDGE	Frame Sync Edge Detection
0x0	Positive Edge Detection
0x1	Negative Edge Detection

24.9.7 SSC Receive Holding Register

Name: RHR

Access Type: Read-only

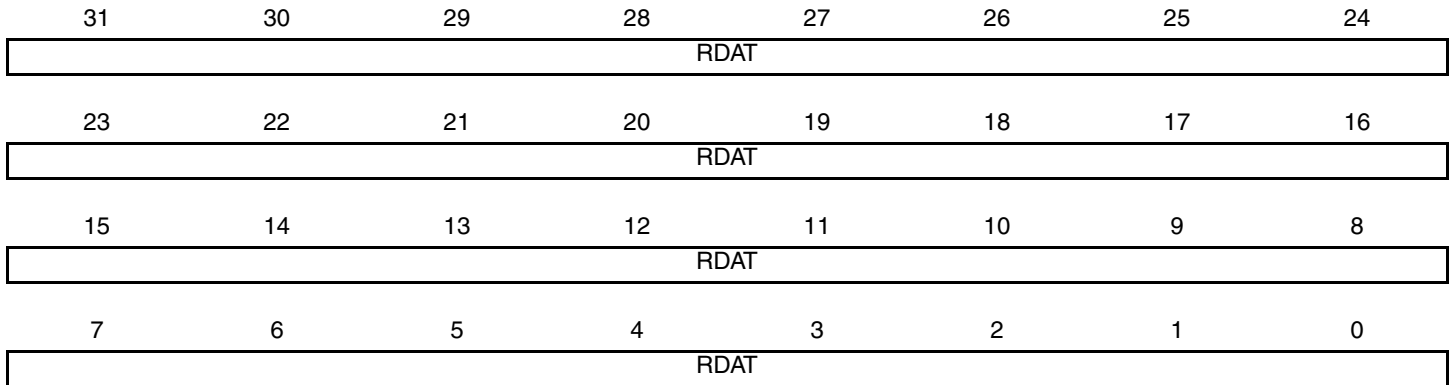

- **RDAT: Receive Data**

Right aligned regardless of the number of data bits defined by DATLEN in RFMR.

24.9.8 SSC Transmit Holding Register

Name: THR

Access Type: Write-only

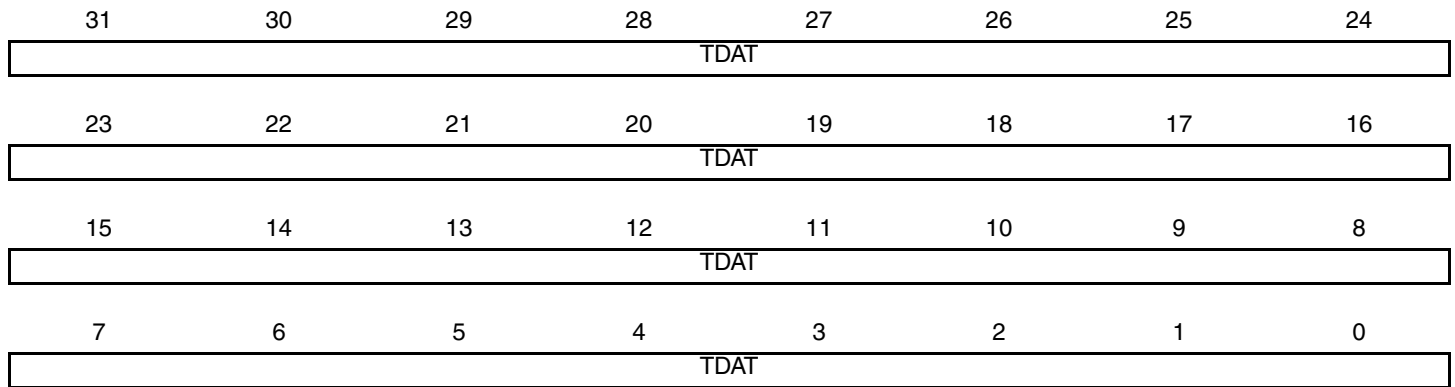

- **TDAT: Transmit Data**

Right aligned regardless of the number of data bits defined by DATLEN in TFMR.

24.9.9 SSC Receive Synchronization Holding Register

Name: RSHR

Access Type: Read-only

31	30	29	28	27	26	25	24
-	-	-	-	-	-	-	-
23	22	21	20	19	18	17	16
-	-	-	-	-	-	-	-
15	14	13	12	11	10	9	8
RSDAT							
7	6	5	4	3	2	1	0
RSDAT							

- **RSDAT: Receive Synchronization Data**

24.9.10 SSC Transmit Synchronization Holding Register

Name: TSHR

Access Type: Read/Write

31	30	29	28	27	26	25	24
-	-	-	-	-	-	-	-
23	22	21	20	19	18	17	16
-	-	-	-	-	-	-	-
15	14	13	12	11	10	9	8
TSDAT							
7	6	5	4	3	2	1	0
TSDAT							

- **TSDAT: Transmit Synchronization Data**

24.9.11 SSC Receive Compare 0 Register

Name: RC0R

Access Type: Read/Write

31	30	29	28	27	26	25	24
-	-	-	-	-	-	-	-
23	22	21	20	19	18	17	16
-	-	-	-	-	-	-	-
15	14	13	12	11	10	9	8
CP0							
7	6	5	4	3	2	1	0
CP0							

- CP0: Receive Compare Data 0

24.9.12 SSC Receive Compare 1 Register

Name: RC1R

Access Type: Read/Write

31	30	29	28	27	26	25	24
-	-	-	-	-	-	-	-
23	22	21	20	19	18	17	16
-	-	-	-	-	-	-	-
15	14	13	12	11	10	9	8
CP1							
7	6	5	4	3	2	1	0
CP1							

- **CP1: Receive Compare Data 1**

24.9.13 SSC Status Register

Name: SR

Access Type: Read-only

31	30	29	28	27	26	25	24
–	–	–	–	–	–	–	–
23	22	21	20	19	18	17	16
–	–	–	–	–	–	RXEN	TXEN
15	14	13	12	11	10	9	8
–	–	–	–	RXSYN	TXSYN	CP1	CP0
7	6	5	4	3	2	1	0
RXBUFF	ENDRX	OVRUN	RXRDY	TXBUFE	ENDTX	TXEMPTY	TXRDY

- **TXRDY: Transmit Ready**

0: Data has been loaded in THR and is waiting to be loaded in the Transmit Shift Register (TSR).

1: THR is empty.

- **TXEMPTY: Transmit Empty**

0: Data remains in THR or is currently transmitted from TSR.

1: Last data written in THR has been loaded in TSR and last data loaded in TSR has been transmitted.

- **ENDTX: End of Transmission**

0: The register TCR has not reached 0 since the last write in TCR or TNCR.

1: The register TCR has reached 0 since the last write in TCR or TNCR.

- **TXBUFE: Transmit Buffer Empty**

0: TCR or TNCR have a value other than 0.

1: Both TCR and TNCR have a value of 0.

- **RXRDY: Receive Ready**

0: RHR is empty.

1: Data has been received and loaded in RHR.

- **OVRUN: Receive Overrun**

0: No data has been loaded in RHR while previous data has not been read since the last read of the Status Register.

1: Data has been loaded in RHR while previous data has not yet been read since the last read of the Status Register.

- **ENDRX: End of Reception**

0: Data is written on the Receive Counter Register or Receive Next Counter Register.

1: End of PDC transfer when Receive Counter Register has arrived at zero.

- **RXBUFF: Receive Buffer Full**

0: RCR or RNCR have a value other than 0.

1: Both RCR and RNCR have a value of 0.

- **CP0: Compare 0**

0: A compare 0 has not occurred since the last read of the Status Register.

1: A compare 0 has occurred since the last read of the Status Register.

- **CP1: Compare 1**

0: A compare 1 has not occurred since the last read of the Status Register.

1: A compare 1 has occurred since the last read of the Status Register.

- **TXSYN: Transmit Sync**

0: A Tx Sync has not occurred since the last read of the Status Register.

1: A Tx Sync has occurred since the last read of the Status Register.

- **RXSYN: Receive Sync**

0: An Rx Sync has not occurred since the last read of the Status Register.

1: An Rx Sync has occurred since the last read of the Status Register.

- **TXEN: Transmit Enable**

0: Transmit is disabled.

1: Transmit is enabled.

- **RXEN: Receive Enable**

0: Receive is disabled.

1: Receive is enabled.

24.9.14 SSC Interrupt Enable Register

Name: IER

Access Type: Write-only

31	30	29	28	27	26	25	24
–	–	–	–	–	–	–	–
23	22	21	20	19	18	17	16
–	–	–	–	–	–	–	–
15	14	13	12	11	10	9	8
–	–	–	–	RXSYN	TXSYN	CP1	CP0
7	6	5	4	3	2	1	0
RXBUFF	ENDRX	OVRUN	RXRDY	TXBUFE	ENDTX	TXEMPTY	TXRDY

- **TXRDY: Transmit Ready Interrupt Enable**

0: No effect.

1: Enables the Transmit Ready Interrupt.

- **TXEMPTY: Transmit Empty Interrupt Enable**

0: No effect.

1: Enables the Transmit Empty Interrupt.

- **ENDTX: End of Transmission Interrupt Enable**

0: No effect.

1: Enables the End of Transmission Interrupt.

- **TXBUFE: Transmit Buffer Empty Interrupt Enable**

0: No effect.

1: Enables the Transmit Buffer Empty Interrupt

- **RXRDY: Receive Ready Interrupt Enable**

0: No effect.

1: Enables the Receive Ready Interrupt.

- **OVRUN: Receive Overrun Interrupt Enable**

0: No effect.

1: Enables the Receive Overrun Interrupt.

- **ENDRX: End of Reception Interrupt Enable**

0: No effect.

1: Enables the End of Reception Interrupt.

- **RXBUFF: Receive Buffer Full Interrupt Enable**

0: No effect.

1: Enables the Receive Buffer Full Interrupt.

- **CP0: Compare 0 Interrupt Enable**

0: No effect.

1: Enables the Compare 0 Interrupt.

- **CP1: Compare 1 Interrupt Enable**

0: No effect.

1: Enables the Compare 1 Interrupt.

- **TXSYN: Tx Sync Interrupt Enable**

0: No effect.

1: Enables the Tx Sync Interrupt.

- **RXSYN: Rx Sync Interrupt Enable**

0: No effect.

1: Enables the Rx Sync Interrupt.

24.9.15 SSC Interrupt Disable Register

Name: IDR

Access Type: Write-only

31	30	29	28	27	26	25	24
–	–	–	–	–	–	–	–
23	22	21	20	19	18	17	16
–	–	–	–	–	–	–	–
15	14	13	12	11	10	9	8
–	–	–	–	RXSYN	TXSYN	CP1	CP0
7	6	5	4	3	2	1	0
RXBUFF	ENDRX	OVRUN	RXRDY	TXBUFE	ENDTX	TXEMPTY	TXRDY

- **TXRDY: Transmit Ready Interrupt Disable**

0: No effect.

1: Disables the Transmit Ready Interrupt.

- **TXEMPTY: Transmit Empty Interrupt Disable**

0: No effect.

1: Disables the Transmit Empty Interrupt.

- **ENDTX: End of Transmission Interrupt Disable**

0: No effect.

1: Disables the End of Transmission Interrupt.

- **TXBUFE: Transmit Buffer Empty Interrupt Disable**

0: No effect.

1: Disables the Transmit Buffer Empty Interrupt.

- **RXRDY: Receive Ready Interrupt Disable**

0: No effect.

1: Disables the Receive Ready Interrupt.

- **OVRUN: Receive Overrun Interrupt Disable**

0: No effect.

1: Disables the Receive Overrun Interrupt.

- **ENDRX: End of Reception Interrupt Disable**

0: No effect.

1: Disables the End of Reception Interrupt.

- **RXBUFF: Receive Buffer Full Interrupt Disable**

0: No effect.

1: Disables the Receive Buffer Full Interrupt.

- **CP0: Compare 0 Interrupt Disable**

0: No effect.

1: Disables the Compare 0 Interrupt.

- **CP1: Compare 1 Interrupt Disable**

0: No effect.

1: Disables the Compare 1 Interrupt.

- **TXSYN: Tx Sync Interrupt Enable**

0: No effect.

1: Disables the Tx Sync Interrupt.

- **RXSYN: Rx Sync Interrupt Enable**

0: No effect.

1: Disables the Rx Sync Interrupt.

24.9.16 SSC Interrupt Mask Register

Name: IMR

Access Type: Read-only

31	30	29	28	27	26	25	24
–	–	–	–	–	–	–	–
23	22	21	20	19	18	17	16
–	–	–	–	–	–	–	–
15	14	13	12	11	10	9	8
–	–	–	–	RXSYN	TXSYN	CP1	CP0
7	6	5	4	3	2	1	0
RXBUF	ENDRX	OVRUN	RXRDY	TXBUFE	ENDTX	TXEMPTY	TXRDY

- **TXRDY: Transmit Ready Interrupt Mask**

0: The Transmit Ready Interrupt is disabled.

1: The Transmit Ready Interrupt is enabled.

- **TXEMPTY: Transmit Empty Interrupt Mask**

0: The Transmit Empty Interrupt is disabled.

1: The Transmit Empty Interrupt is enabled.

- **ENDTX: End of Transmission Interrupt Mask**

0: The End of Transmission Interrupt is disabled.

1: The End of Transmission Interrupt is enabled.

- **TXBUFE: Transmit Buffer Empty Interrupt Mask**

0: The Transmit Buffer Empty Interrupt is disabled.

1: The Transmit Buffer Empty Interrupt is enabled.

- **RXRDY: Receive Ready Interrupt Mask**

0: The Receive Ready Interrupt is disabled.

1: The Receive Ready Interrupt is enabled.

- **OVRUN: Receive Overrun Interrupt Mask**

0: The Receive Overrun Interrupt is disabled.

1: The Receive Overrun Interrupt is enabled.

- **ENDRX: End of Reception Interrupt Mask**

0: The End of Reception Interrupt is disabled.

1: The End of Reception Interrupt is enabled.

- **RXBUFF: Receive Buffer Full Interrupt Mask**

0: The Receive Buffer Full Interrupt is disabled.

1: The Receive Buffer Full Interrupt is enabled.

- **CP0: Compare 0 Interrupt Mask**

0: The Compare 0 Interrupt is disabled.

1: The Compare 0 Interrupt is enabled.

- **CP1: Compare 1 Interrupt Mask**

0: The Compare 1 Interrupt is disabled.

1: The Compare 1 Interrupt is enabled.

- **TXSYN: Tx Sync Interrupt Mask**

0: The Tx Sync Interrupt is disabled.

1: The Tx Sync Interrupt is enabled.

- **RXSYN: Rx Sync Interrupt Mask**

0: The Rx Sync Interrupt is disabled.

1: The Rx Sync Interrupt is enabled.

25. Universal Synchronous/Asynchronous Receiver/Transmitter (USART)

Rev: 6089I

25.1 Features

- **Programmable Baud Rate Generator**
- **5- to 9-bit Full-duplex Synchronous or Asynchronous Serial Communications**
 - 1, 1.5 or 2 Stop Bits in Asynchronous Mode or 1 or 2 Stop Bits in Synchronous Mode
 - Parity Generation and Error Detection
 - Framing Error Detection, Overrun Error Detection
 - MSB- or LSB-first
 - Optional Break Generation and Detection
 - By 8 or by 16 Over-sampling Receiver Frequency
 - Optional Hardware Handshaking RTS-CTS
 - Receiver Time-out and Transmitter Timeguard
 - Optional Multidrop Mode with Address Generation and Detection
- **RS485 with Driver Control Signal**
- **ISO7816, T = 0 or T = 1 Protocols for Interfacing with Smart Cards**
 - NACK Handling, Error Counter with Repetition and Iteration Limit
- **IrDA Modulation and Demodulation**
 - Communication at up to 115.2 Kbps
- **Test Modes**
 - Remote Loopback, Local Loopback, Automatic Echo
- **Supports Connection of Two Peripheral DMA Controller Channels (PDC)**
 - Offers Buffer Transfer without Processor Intervention

25.2 Description

The Universal Synchronous Asynchronous Receiver Transceiver (USART) provides one full duplex universal synchronous asynchronous serial link. Data frame format is widely programmable (data length, parity, number of stop bits) to support a maximum of standards. The receiver implements parity error, framing error and overrun error detection. The receiver time-out enables handling variable-length frames and the transmitter timeguard facilitates communications with slow remote devices. Multidrop communications are also supported through address bit handling in reception and transmission.

The USART features three test modes: remote loopback, local loopback and automatic echo.

The USART supports specific operating modes providing interfaces on RS485 buses, with ISO7816 T = 0 or T = 1 smart card slots and infrared transceivers. The hardware handshaking feature enables an out-of-band flow control by automatic management of the pins RTS and CTS.

The USART supports the connection to the Peripheral DMA Controller, which enables data transfers to the transmitter and from the receiver. The PDC provides chained buffer management without any intervention of the processor.

25.3 Block Diagram

Figure 25-1. USART Block Diagram

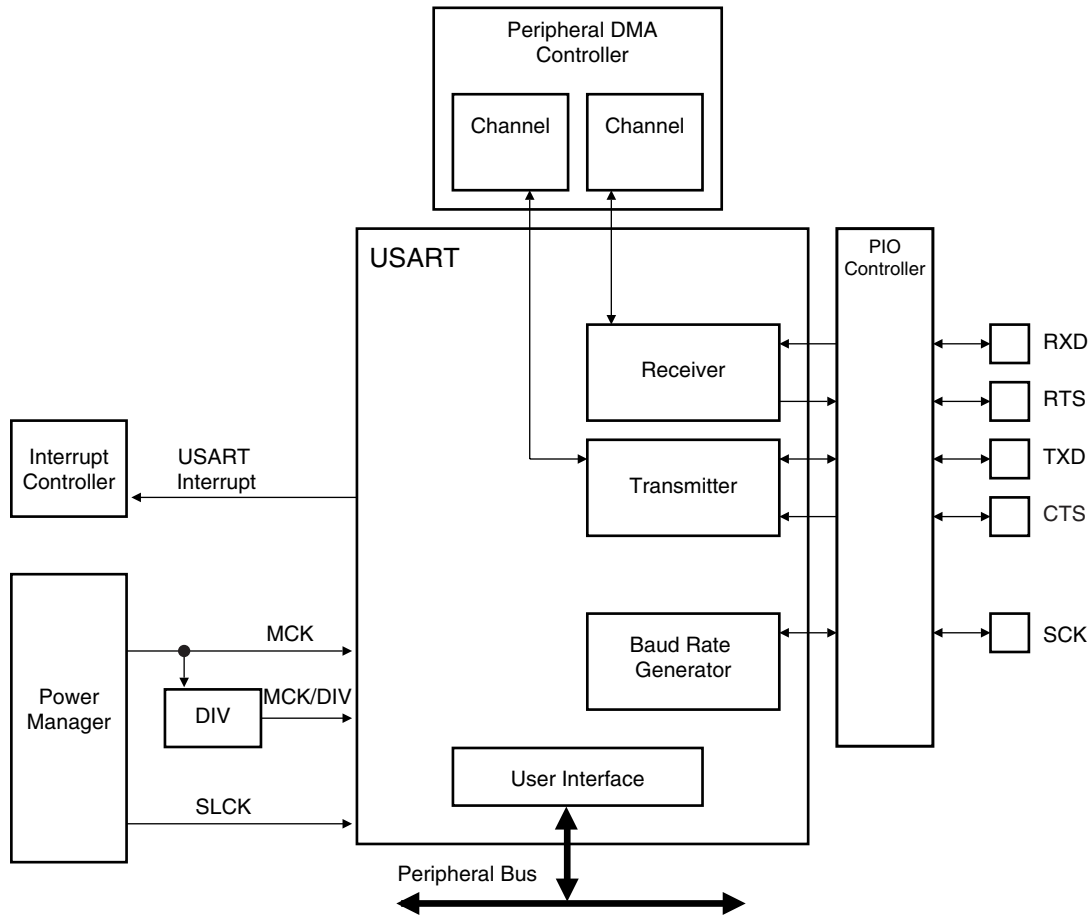

25.4 Application Block Diagram

Figure 25-2. Application Block Diagram

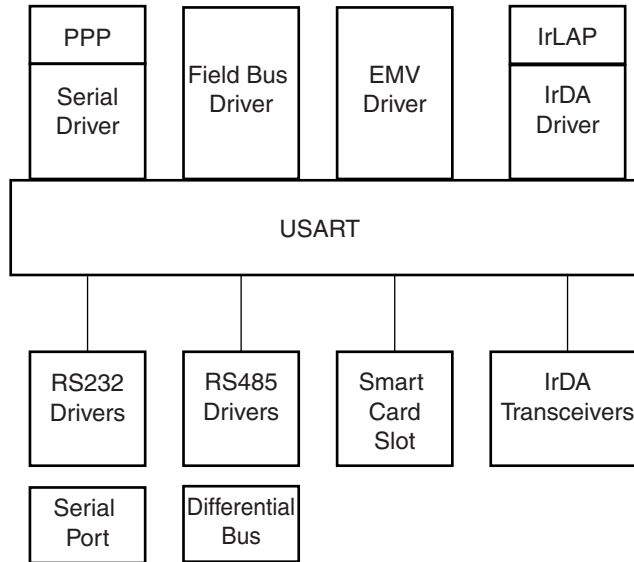

25.5 I/O Lines Description

Table 25-1. I/O Line Description

Name	Description	Type	Active Level
SCK	Serial Clock	I/O	
TXD	Transmit Serial Data	I/O	
RXD	Receive Serial Data	Input	
CTS	Clear to Send	Input	Low
RTS	Request to Send	Output	Low

25.6 Product Dependencies

25.6.1 I/O Lines

The pins used for interfacing the USART may be multiplexed with the PIO lines. The programmer must first program the PIO controller to assign the desired USART pins to their peripheral function. If I/O lines of the USART are not used by the application, they can be used for other purposes by the PIO Controller.

To prevent the TXD line from falling when the USART is disabled, the use of an internal pull up is mandatory.

25.6.2 Power Management

The USART is not continuously clocked. The programmer must ensure that the USART clock is enabled in the Power Manager (PM) before using the USART. However, if the application does not require USART operations, the USART clock can be stopped when not needed and be restarted later. In this case, the USART will resume its operations where it left off. Master Clock (MCK) in the USART description is the clock for the peripheral bus to which the USART is connected.

25.6.3 Interrupt

The USART interrupt line is connected on one of the internal sources of the Interrupt Controller. Using the USART interrupt requires the interrupt controller to be programmed first.

25.7 Functional Description

The USART is capable of managing several types of serial synchronous or asynchronous communications.

It supports the following communication modes:

- 5- to 9-bit full-duplex asynchronous serial communication
 - MSB- or LSB-first
 - 1, 1.5 or 2 stop bits
 - Parity even, odd, marked, space or none
 - By 8 or by 16 over-sampling receiver frequency
 - Optional hardware handshaking
 - Optional break management
 - Optional multidrop serial communication
- High-speed 5- to 9-bit full-duplex synchronous serial communication
 - MSB- or LSB-first
 - 1 or 2 stop bits
 - Parity even, odd, marked, space or none
 - By 8 or by 16 over-sampling frequency
 - Optional hardware handshaking
 - Optional break management
 - Optional multidrop serial communication
- RS485 with driver control signal
- ISO7816, T0 or T1 protocols for interfacing with smart cards
 - NACK handling, error counter with repetition and iteration limit
- InfraRed IrDA Modulation and Demodulation
- Test modes
 - Remote loopback, local loopback, automatic echo

25.7.1 Baud Rate Generator

The Baud Rate Generator provides the bit period clock named the Baud Rate Clock to both the receiver and the transmitter.

The Baud Rate Generator clock source can be selected by setting the USCLKS field in the Mode Register (MR) between:

- the Master Clock MCK
- a division of the Master Clock, the divider being product dependent, but generally set to 8
- the external clock, available on the SCK pin

The Baud Rate Generator is based upon a 16-bit divider, which is programmed with the CD field of the Baud Rate Generator Register (BRGR). If CD is programmed at 0, the Baud Rate Generator does not generate any clock. If CD is programmed at 1, the divider is bypassed and becomes inactive.

If the external SCK clock is selected, the duration of the low and high levels of the signal provided on the SCK pin must be longer than a Master Clock (MCK) period. The frequency of the signal provided on SCK must be at least 4.5 times lower than MCK.

Figure 25-3. Baud Rate Generator

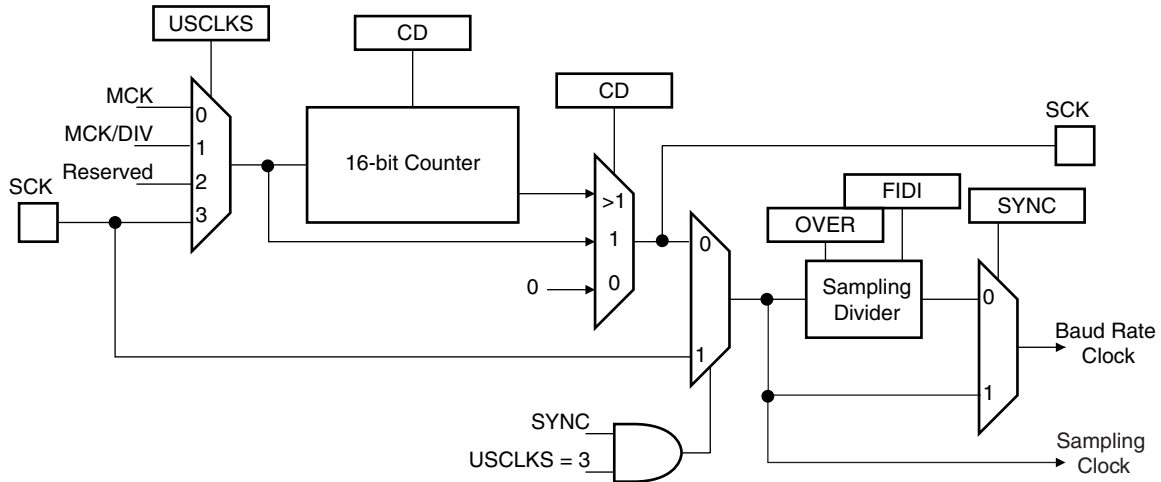

25.7.1.1 Baud Rate in Asynchronous Mode

If the USART is programmed to operate in asynchronous mode, the selected clock is first divided by CD, which is field programmed in the Baud Rate Generator Register (BRGR). The resulting clock is provided to the receiver as a sampling clock and then divided by 16 or 8, depending on the programming of the OVER bit in MR.

If OVER is set to 1, the receiver sampling is 8 times higher than the baud rate clock. If OVER is cleared, the sampling is performed at 16 times the baud rate clock.

The following formula performs the calculation of the Baud Rate.

$$Baudrate = \frac{SelectedClock}{(8(2 - Over)CD)}$$

This gives a maximum baud rate of MCK divided by 8, assuming that MCK is the highest possible clock and that OVER is programmed at 1.

25.7.1.2 Baud Rate Calculation Example

Table 25-2 shows calculations of CD to obtain a baud rate at 38400 bauds for different source clock frequencies. This table also shows the actual resulting baud rate and the error.

Table 25-2. Baud Rate Example (OVER = 0)

Source Clock	Expected Baud Rate	Calculation Result	CD	Actual Baud Rate	Error
MHz	Bit/s			Bit/s	
3 686 400	38 400	6.00	6	38 400.00	0.00%
4 915 200	38 400	8.00	8	38 400.00	0.00%
5 000 000	38 400	8.14	8	39 062.50	1.70%

Table 25-2. Baud Rate Example (OVER = 0) (Continued)

Source Clock	Expected Baud Rate	Calculation Result	CD	Actual Baud Rate	Error
7 372 800	38 400	12.00	12	38 400.00	0.00%
8 000 000	38 400	13.02	13	38 461.54	0.16%
12 000 000	38 400	19.53	20	37 500.00	2.40%
12 288 000	38 400	20.00	20	38 400.00	0.00%
14 318 180	38 400	23.30	23	38 908.10	1.31%
14 745 600	38 400	24.00	24	38 400.00	0.00%
18 432 000	38 400	30.00	30	38 400.00	0.00%
24 000 000	38 400	39.06	39	38 461.54	0.16%
24 576 000	38 400	40.00	40	38 400.00	0.00%
25 000 000	38 400	40.69	40	38 109.76	0.76%
32 000 000	38 400	52.08	52	38 461.54	0.16%
32 768 000	38 400	53.33	53	38 641.51	0.63%
33 000 000	38 400	53.71	54	38 194.44	0.54%
40 000 000	38 400	65.10	65	38 461.54	0.16%
50 000 000	38 400	81.38	81	38 580.25	0.47%
60 000 000	38 400	97.66	98	38 265.31	0.35%
70 000 000	38 400	113.93	114	38 377.19	0.06%

The baud rate is calculated with the following formula:

$$BaudRate = MCK / CD \times 16$$

The baud rate error is calculated with the following formula. It is not recommended to work with an error higher than 5%.

$$Error = 1 - \left(\frac{ExpectedBaudRate}{ActualBaudRate} \right)$$

25.7.1.3 Fractional Baud Rate in Asynchronous Mode

The Baud Rate generator previously defined is subject to the following limitation: the output frequency changes by only integer multiples of the reference frequency. An approach to this problem is to integrate a fractional N clock generator that has a high resolution. The generator architecture is modified to obtain Baud Rate changes by a fraction of the reference source clock. This fractional part is programmed with the FP field in the Baud Rate Generator Register (BRGR). If FP is not 0, the fractional part is activated. The resolution is one eighth of the clock divider. This feature is only available when using USART normal mode. The fractional Baud Rate is calculated using the following formula:

$$Baudrate = \frac{SelectedClock}{(8(2 - Over) \left(CD + \frac{FP}{8} \right))}$$

The modified architecture is presented below:

Figure 25-4. Fractional Baud Rate Generator

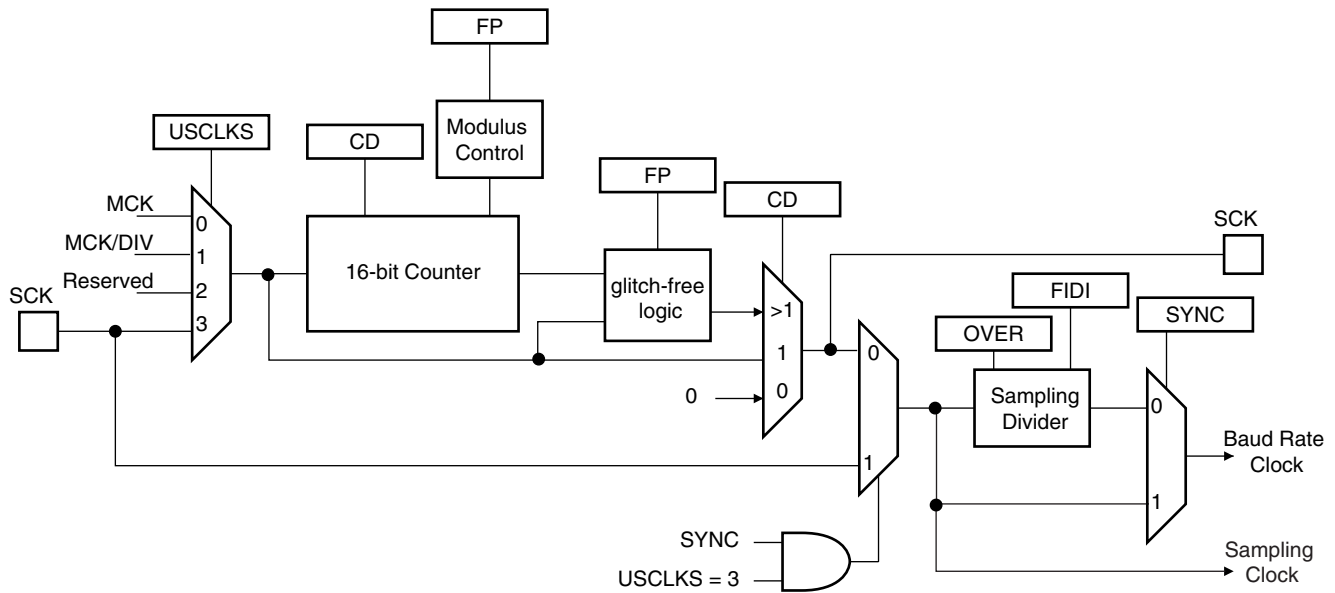

25.7.1.4 Baud Rate in Synchronous Mode

If the USART is programmed to operate in synchronous mode, the selected clock is simply divided by the field CD in BRGR.

$$\text{BaudRate} = \frac{\text{SelectedClock}}{CD}$$

In synchronous mode, if the external clock is selected (USCLKS = 3), the clock is provided directly by the signal on the USART SCK pin. No division is active. The value written in BRGR has no effect. The external clock frequency must be at least 4.5 times lower than the system clock.

When either the external clock SCK or the internal clock divided (MCK/DIV) is selected, the value programmed in CD must be even if the user has to ensure a 50:50 mark/space ratio on the SCK pin. If the internal clock MCK is selected, the Baud Rate Generator ensures a 50:50 duty cycle on the SCK pin, even if the value programmed in CD is odd.

25.7.1.5 Baud Rate in ISO 7816 Mode

The ISO7816 specification defines the bit rate with the following formula:

$$B = \frac{D_i}{F_i} \times f$$

where:

- B is the bit rate
- Di is the bit-rate adjustment factor
- Fi is the clock frequency division factor
- f is the ISO7816 clock frequency (Hz)

Di is a binary value encoded on a 4-bit field, named DI, as represented in [Table 25-3](#).

Table 25-3. Binary and Decimal Values for Di

DI field	0001	0010	0011	0100	0101	0110	1000	1001
Di (decimal)	1	2	4	8	16	32	12	20

Fi is a binary value encoded on a 4-bit field, named FI, as represented in [Table 25-4](#).

Table 25-4. Binary and Decimal Values for Fi

FI field	0000	0001	0010	0011	0100	0101	0110	1001	1010	1011	1100	1101
Fi (decimal)	372	372	558	744	1116	1488	1860	512	768	1024	1536	2048

[Table 25-5](#) shows the resulting Fi/Di Ratio, which is the ratio between the ISO7816 clock and the baud rate clock.

Table 25-5. Possible Values for the Fi/Di Ratio

Fi/Di	372	558	774	1116	1488	1806	512	768	1024	1536	2048
1	372	558	744	1116	1488	1860	512	768	1024	1536	2048
2	186	279	372	558	744	930	256	384	512	768	1024
4	93	139.5	186	279	372	465	128	192	256	384	512
8	46.5	69.75	93	139.5	186	232.5	64	96	128	192	256
16	23.25	34.87	46.5	69.75	93	116.2	32	48	64	96	128
32	11.62	17.43	23.25	34.87	46.5	58.13	16	24	32	48	64
12	31	46.5	62	93	124	155	42.66	64	85.33	128	170.6
20	18.6	27.9	37.2	55.8	74.4	93	25.6	38.4	51.2	76.8	102.4

If the USART is configured in ISO7816 Mode, the clock selected by the USCLKS field in the Mode Register (MR) is first divided by the value programmed in the field CD in the Baud Rate Generator Register (BRGR). The resulting clock can be provided to the SCK pin to feed the smart card clock inputs. This means that the CLKO bit can be set in MR.

This clock is then divided by the value programmed in the FI_DI_RATIO field in the FI_DI_Ratio register (FIDI). This is performed by the Sampling Divider, which performs a division by up to 2047 in ISO7816 Mode. The non-integer values of the Fi/Di Ratio are not supported and the user must program the FI_DI_RATIO field to a value as close as possible to the expected value.

The FI_DI_RATIO field resets to the value 0x174 (372 in decimal) and is the most common divider between the ISO7816 clock and the bit rate (Fi = 372, Di = 1).

[Figure 25-5](#) shows the relation between the Elementary Time Unit, corresponding to a bit time, and the ISO 7816 clock.

Figure 25-5. Elementary Time Unit (ETU)

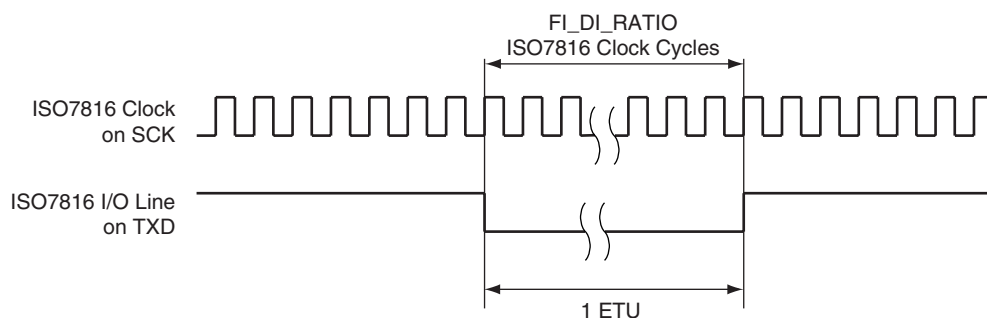

25.7.2 Receiver and Transmitter Control

After reset, the receiver is disabled. The user must enable the receiver by setting the RXEN bit in the Control Register (CR). However, the receiver registers can be programmed before the receiver clock is enabled.

After reset, the transmitter is disabled. The user must enable it by setting the TXEN bit in the Control Register (CR). However, the transmitter registers can be programmed before being enabled.

The Receiver and the Transmitter can be enabled together or independently.

At any time, the software can perform a reset on the receiver or the transmitter of the USART by setting the corresponding bit, RSTRX and RSTTX respectively, in the Control Register (CR). The reset commands have the same effect as a hardware reset on the corresponding logic. Regardless of what the receiver or the transmitter is performing, the communication is immediately stopped.

The user can also independently disable the receiver or the transmitter by setting RXDIS and TXDIS respectively in CR. If the receiver is disabled during a character reception, the USART waits until the end of reception of the current character, then the reception is stopped. If the transmitter is disabled while it is operating, the USART waits the end of transmission of both the current character and character being stored in the Transmit Holding Register (THR). If a time-guard is programmed, it is handled normally.

25.7.3 Synchronous and Asynchronous Modes

25.7.3.1 Transmitter Operations

The transmitter performs the same in both synchronous and asynchronous operating modes (SYNC = 0 or SYNC = 1). One start bit, up to 9 data bits, one optional parity bit and up to two stop bits are successively shifted out on the TXD pin at each falling edge of the programmed serial clock.

The number of data bits is selected by the CHRL field and the MODE 9 bit in the Mode Register (MR). Nine bits are selected by setting the MODE 9 bit regardless of the CHRL field. The parity bit is set according to the PAR field in MR. The even, odd, space, marked or none parity bit can be configured. The MSBF field in MR configures which data bit is sent first. If written at 1, the most significant bit is sent first. At 0, the less significant bit is sent first. The number of stop bits is selected by the NBSTOP field in MR. The 1.5 stop bit is supported in asynchronous mode only.

Figure 25-6. Character Transmit

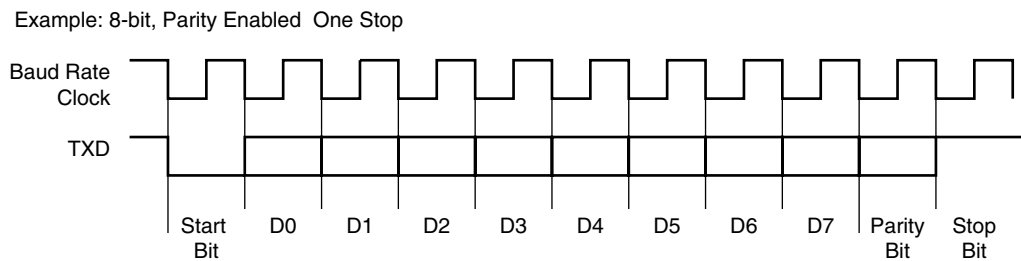

The characters are sent by writing in the Transmit Holding Register (THR). The transmitter reports two status bits in the Channel Status Register (CSR): TXRDY (Transmitter Ready), which indicates that THR is empty and TXEMPTY, which indicates that all the characters written in THR have been processed. When the current character processing is completed, the last character written in THR is transferred into the Shift Register of the transmitter and THR becomes empty, thus TXRDY raises.

Both TXRDY and TXEMPTY bits are low since the transmitter is disabled. Writing a character in THR while TXRDY is active has no effect and the written character is lost.

Figure 25-7. Transmitter Status

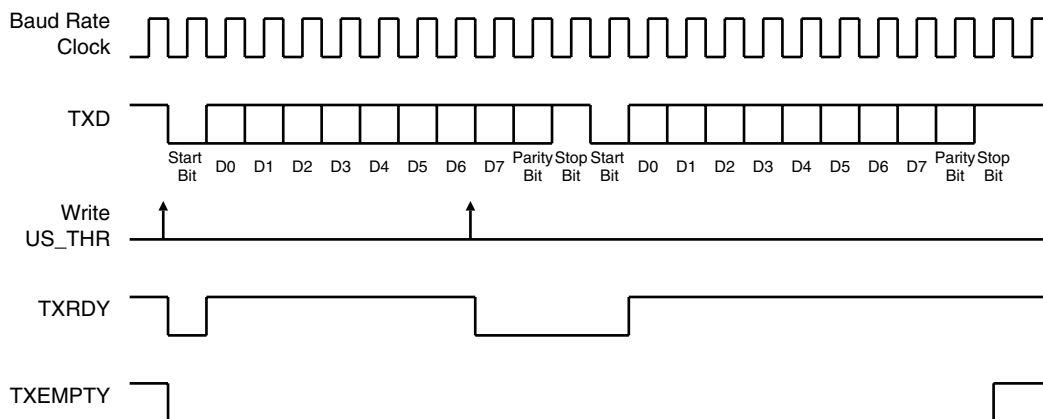

25.7.3.2 Manchester Encoder

When the Manchester encoder is in use, characters transmitted through the USART are encoded based on biphasic Manchester II format. To enable this mode, set the MAN field in the MR register to 1. Depending on polarity configuration, a logic level (zero or one), is transmitted as a coded signal one-to-zero or zero-to-one. Thus, a transition always occurs at the midpoint of each bit time. It consumes more bandwidth than the original NRZ signal (2x) but the receiver has more error control since the expected input must show a change at the center of a bit cell. An example of Manchester encoded sequence is: the byte 0xB1 or 10110001 encodes to 10 01 10 10 01 01 01 10, assuming the default polarity of the encoder. [Figure 25-8](#) illustrates this coding scheme.

Figure 25-8. NRZ to Manchester Encoding

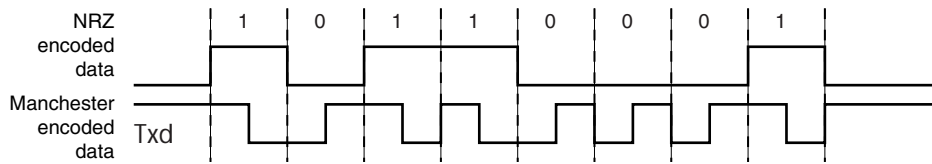

The Manchester encoded character can also be encapsulated by adding both a configurable preamble and a start frame delimiter pattern. Depending on the configuration, the preamble is a training sequence, composed of a pre-defined pattern with a programmable length from 1 to 15 bit times. If the preamble length is set to 0, the preamble waveform is not generated prior to any character. The preamble pattern is chosen among the following sequences: ALL_ONE, ALL_ZERO, ONE_ZERO or ZERO_ONE, writing the field TX_PP in the MAN register, the field TX_PL is used to configure the preamble length. Figure 25-9 illustrates and defines the valid patterns. To improve flexibility, the encoding scheme can be configured using the TX_MPOL field in the MAN register. If the TX_MPOL field is set to zero (default), a logic zero is encoded with a zero-to-one transition and a logic one is encoded with a one-to-zero transition. If the TX_MPOL field is set to one, a logic one is encoded with a one-to-zero transition and a logic zero is encoded with a zero-to-one transition.

Figure 25-9. Preamble Patterns, Default Polarity Assumed

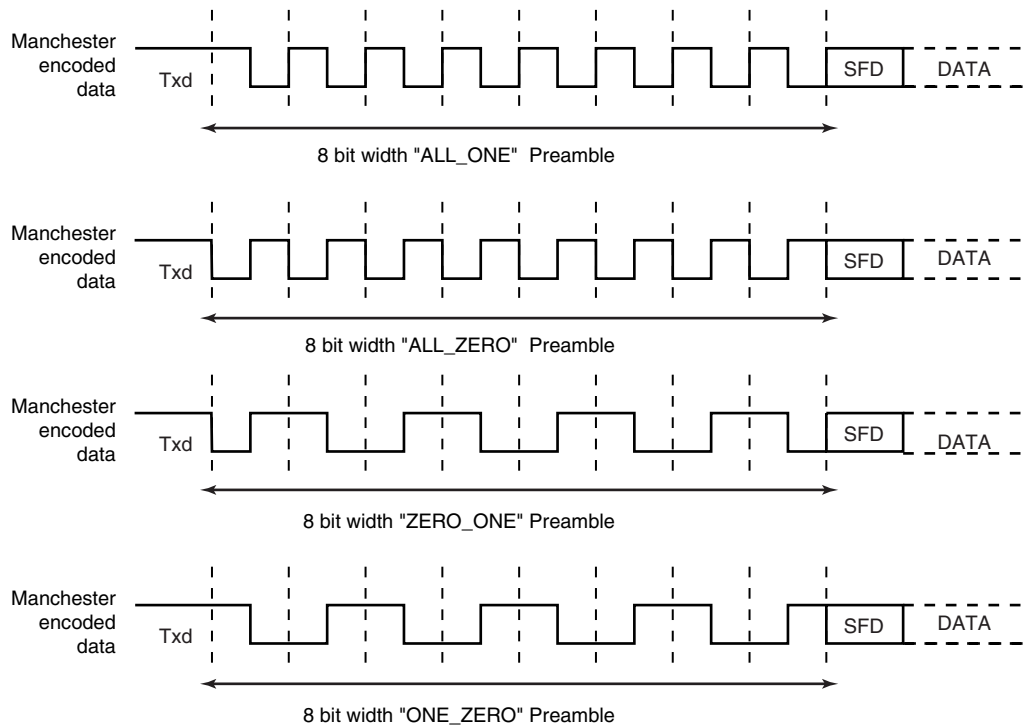

A start frame delimiter is to be configured using the ONEBIT field in the MR register. It consists of a user-defined pattern that indicates the beginning of a valid data. Figure 25-10 illustrates these patterns. If the start frame delimiter, also known as start bit, is one bit, (ONEBIT at 1), a logic zero is Manchester encoded and indicates that a new character is being sent serially on the line. If the start frame delimiter is a synchronization pattern also referred to as sync (ONEBIT at 0), a sequence of 3 bit times is sent serially on the line to indicate the start of a new character.

The sync waveform is in itself an invalid Manchester waveform as the transition occurs at the middle of the second bit time. Two distinct sync patterns are used: the command sync and the data sync. The command sync has a logic one level for one and a half bit times, then a transition to logic zero for the second one and a half bit times. If the MODSYNC field in the MR register is set to 1, the next character is a command. If it is set to 0, the next character is a data. When direct memory access is used, the MODSYNC field can be immediately updated with a modified character located in memory. To enable this mode, VAR_SYNC field in MR register must be set to 1. In this case, the MODSYNC field in MR is bypassed and the sync configuration is held in the TXSYNH in the THR register. The USART character format is modified and includes sync information.

Figure 25-10. Start Frame Delimiter

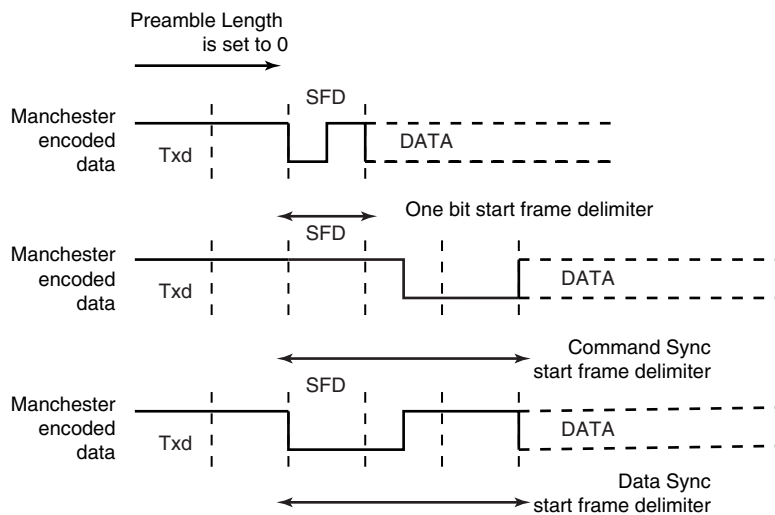

25.7.3.3 Drift Compensation

Drift compensation is available only in 16X oversampling mode. An hardware recovery system allows a larger clock drift. To enable the hardware system, the bit in the MAN register must be set. If the RXD edge is one 16X clock cycle from the expected edge, this is considered as normal jitter and no corrective actions is taken. If the RXD event is between 4 and 2 clock cycles before the expected edge, then the current period is shortened by one clock cycle. If the RXD event is between 2 and 3 clock cycles after the expected edge, then the current period is lengthened by one clock cycle. These intervals are considered to be drift and so corrective actions are automatically taken.

Figure 25-11. Bit Resynchronization

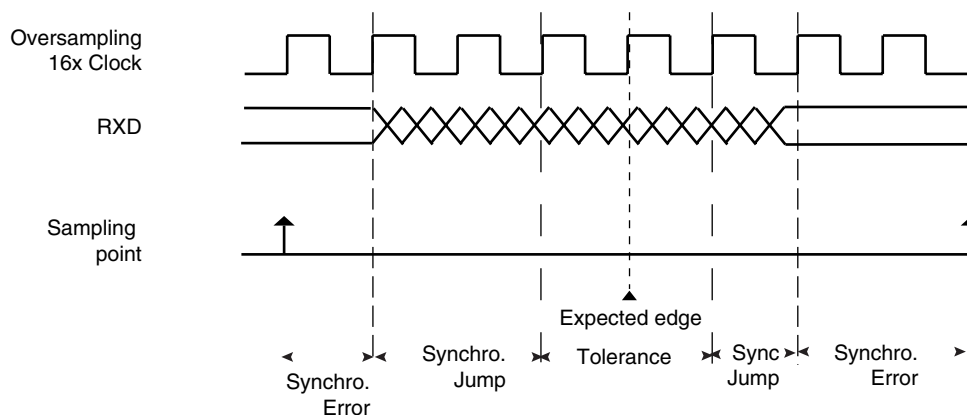

25.7.3.4 Asynchronous Receiver

If the USART is programmed in asynchronous operating mode ($SYNC = 0$), the receiver oversamples the RXD input line. The oversampling is either 16 or 8 times the Baud Rate clock, depending on the OVER bit in the Mode Register (MR).

The receiver samples the RXD line. If the line is sampled during one half of a bit time at 0, a start bit is detected and data, parity and stop bits are successively sampled on the bit rate clock.

If the oversampling is 16, (OVER at 0), a start is detected at the eighth sample at 0. Then, data bits, parity bit and stop bit are sampled on each 16 sampling clock cycle. If the oversampling is 8 (OVER at 1), a start bit is detected at the fourth sample at 0. Then, data bits, parity bit and stop bit are sampled on each 8 sampling clock cycle.

The number of data bits, first bit sent and parity mode are selected by the same fields and bits as the transmitter, i.e. respectively CHRL, MODE9, MSBF and PAR. The number of stop bits has no effect on the receiver as it considers only one stop bit, regardless of the field NBSTOP, so that resynchronization between the receiver and the transmitter can occur. Moreover, as soon as the stop bit is sampled, the receiver starts looking for a new start bit so that resynchronization can also be accomplished when the transmitter is operating with one stop bit.

Figure 25-12 and Figure 25-13 illustrate start detection and character reception when USART operates in asynchronous mode.

Figure 25-12. Asynchronous Start Detection

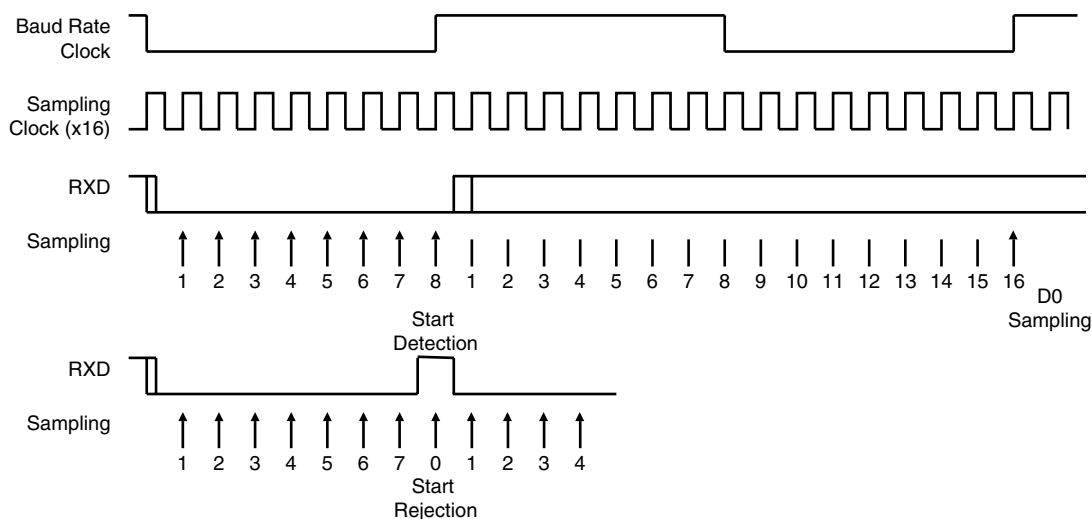
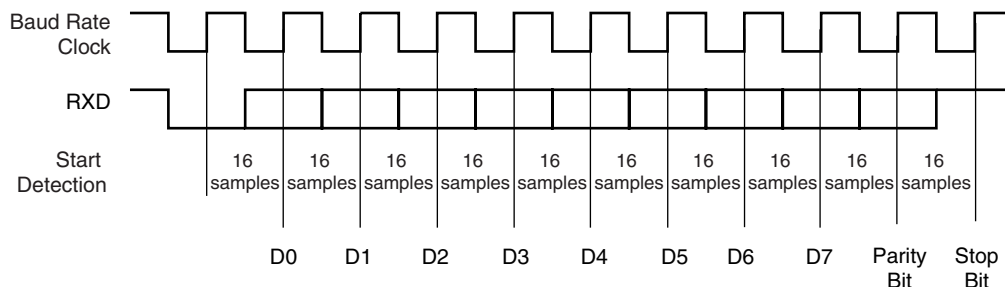

Figure 25-13. Asynchronous Character Reception

Example: 8-bit, Parity Enabled



25.7.3.5 Manchester Decoder

When the MAN field in MR register is set to 1, the Manchester decoder is enabled. The decoder performs both preamble and start frame delimiter detection. One input line is dedicated to Manchester encoded input data.

An optional preamble sequence can be defined, its length is user-defined and totally independent of the emitter side. Use RX_PL in MAN register to configure the length of the preamble sequence. If the length is set to 0, no preamble is detected and the function is disabled. In addition, the polarity of the input stream is programmable with RX_MPOL field in MAN register. Depending on the desired application the preamble pattern matching is to be defined via the RX_PP field in MAN. See Figure 25-9 for available preamble patterns.

Unlike preamble, the start frame delimiter is shared between Manchester Encoder and Decoder. So, if ONEBIT field is set to 1, only a zero encoded Manchester can be detected as a valid start frame delimiter. If ONEBIT is set to 0, only a sync pattern is detected as a valid start frame delimiter. Decoder operates by detecting transition on incoming stream. If RXD is sampled during one quarter of a bit time at zero, a start bit is detected. See Figure 25-14. The sample pulse rejection mechanism applies.

Figure 25-14. Asynchronous Start Bit Detection

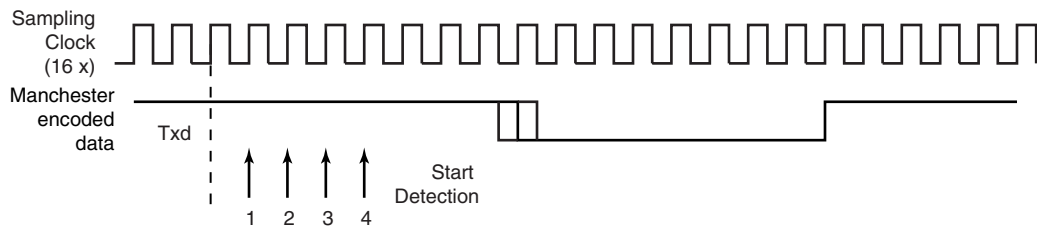

The receiver is activated and starts Preamble and Frame Delimiter detection, sampling the data at one quarter and then three quarters. If a valid preamble pattern or start frame delimiter is detected, the receiver continues decoding with the same synchronization. If the stream does not match a valid pattern or a valid start frame delimiter, the receiver re-synchronizes on the next valid edge. The minimum time threshold to estimate the bit value is three quarters of a bit time.

If a valid preamble (if used) followed with a valid start frame delimiter is detected, the incoming stream is decoded into NRZ data and passed to USART for processing. Figure 25-15 illustrates Manchester pattern mismatch. When incoming data stream is passed to the USART, the receiver is also able to detect Manchester code violation. A code violation is a lack of transition in the middle of a bit cell. In this case, MANE flag in CSR register is raised. It is cleared by writing the Control Register (CR) with the RSTSTA bit at 1. See Figure 25-16 for an example of Manchester error detection during data phase.

Figure 25-15. Preamble Pattern Mismatch

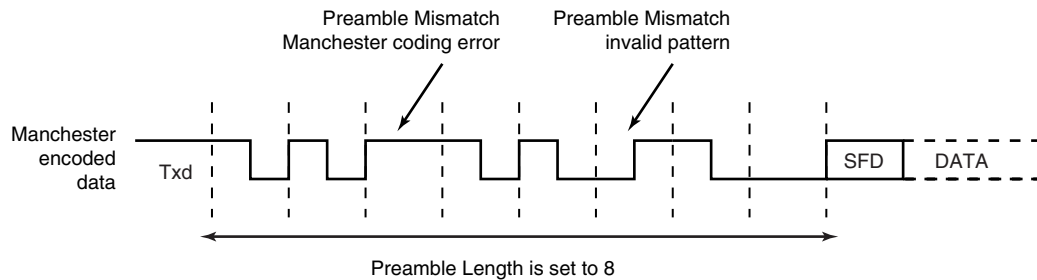
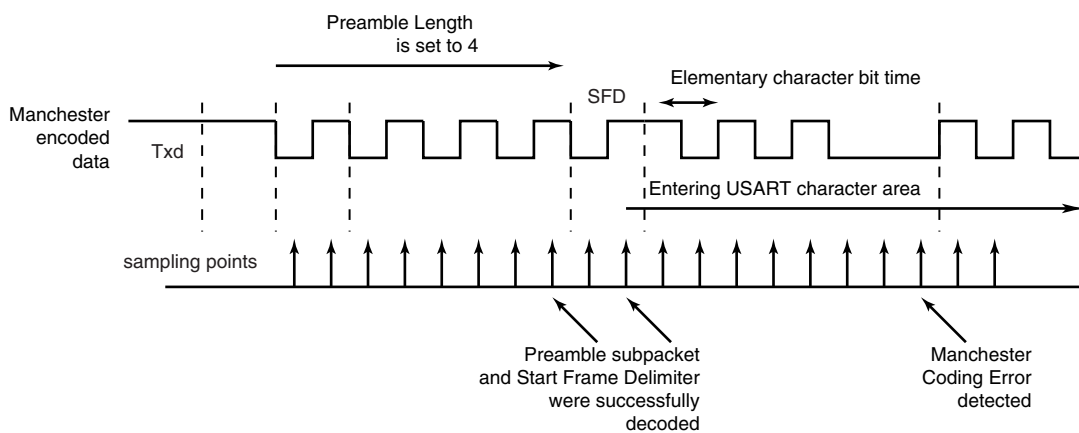

Figure 25-16. Manchester Error Flag



When the start frame delimiter is a sync pattern (ONEBIT field at 0), both command and data delimiter are supported. If a valid sync is detected, the received character is written as RXCHR

field in the RHR register and the RXSYNH is updated. RXCHR is set to 1 when the received character is a command, and it is set to 0 if the received character is a data. This mechanism alleviates and simplifies the direct memory access as the character contains its own sync field in the same register.

As the decoder is setup to be used in unipolar mode, the first bit of the frame has to be a zero-to-one transition.

25.7.3.6 Radio Interface: Manchester Encoded USART Application

This section describes low data rate RF transmission systems and their integration with a Manchester encoded USART. These systems are based on transmitter and receiver ICs that support ASK and FSK modulation schemes.

The goal is to perform full duplex radio transmission of characters using two different frequency carriers. See the configuration in [Figure 25-17](#).

Figure 25-17. Manchester Encoded Characters RF Transmission

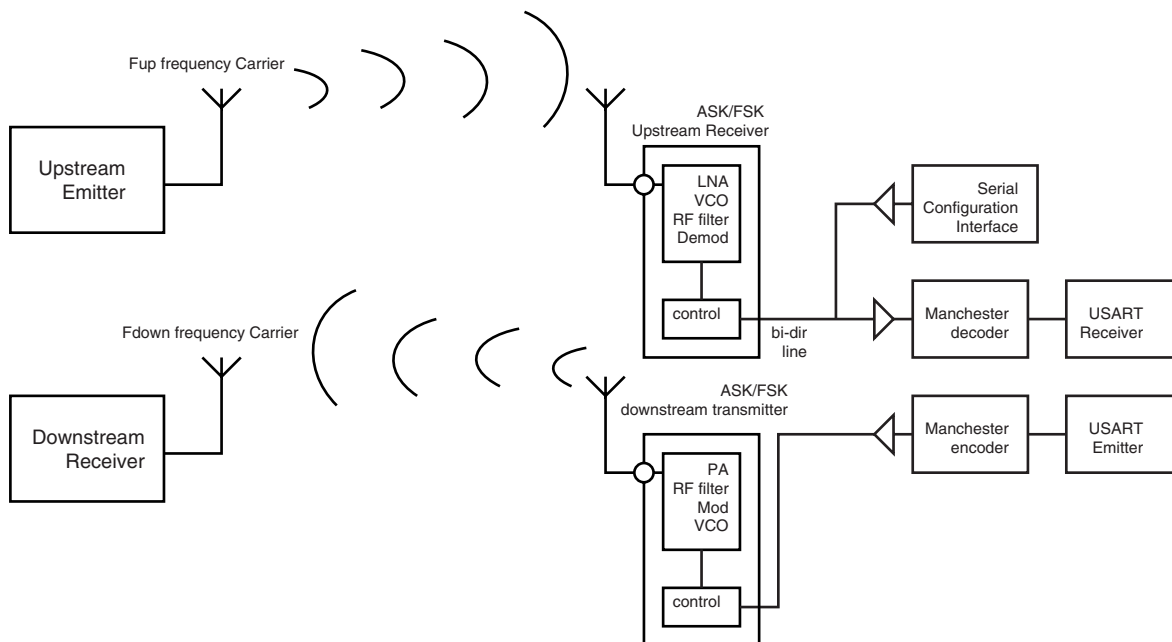

The USART module is configured as a Manchester encoder/decoder. Looking at the downstream communication channel, Manchester encoded characters are serially sent to the RF emitter. This may also include a user defined preamble and a start frame delimiter. Mostly, preamble is used in the RF receiver to distinguish between a valid data from a transmitter and signals due to noise. The Manchester stream is then modulated. See [Figure 25-18](#) for an example of ASK modulation scheme. When a logic one is sent to the ASK modulator, the power amplifier, referred to as PA, is enabled and transmits an RF signal at downstream frequency. When a logic zero is transmitted, the RF signal is turned off. If the FSK modulator is activated, two different frequencies are used to transmit data. When a logic 1 is sent, the modulator outputs an RF signal at frequency F_0 and switches to F_1 if the data sent is a 0. See [Figure 25-19](#).

From the receiver side, another carrier frequency is used. The RF receiver performs a bit check operation examining demodulated data stream. If a valid pattern is detected, the receiver switches to receiving mode. The demodulated stream is sent to the Manchester decoder. Because of bit checking inside RF IC, the data transferred to the microcontroller is reduced by a

user-defined number of bits. The Manchester preamble length is to be defined in accordance with the RF IC configuration.

Figure 25-18. ASK Modulator Output

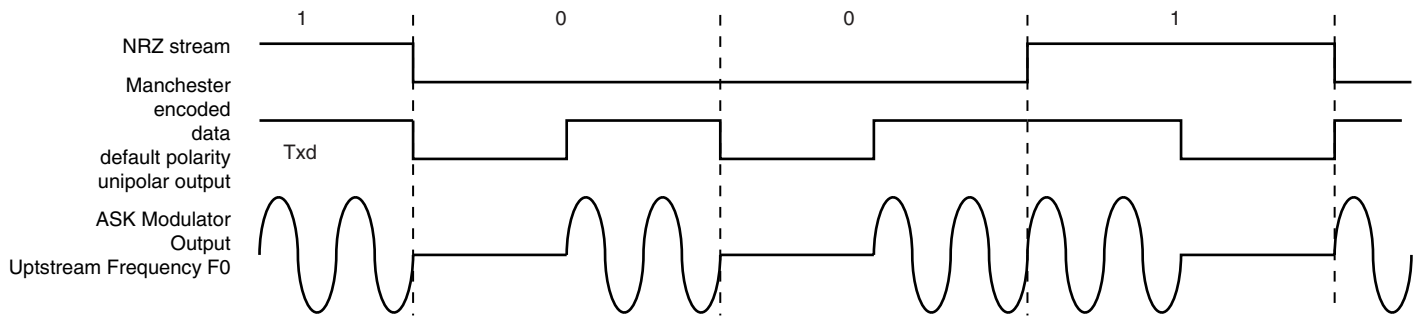
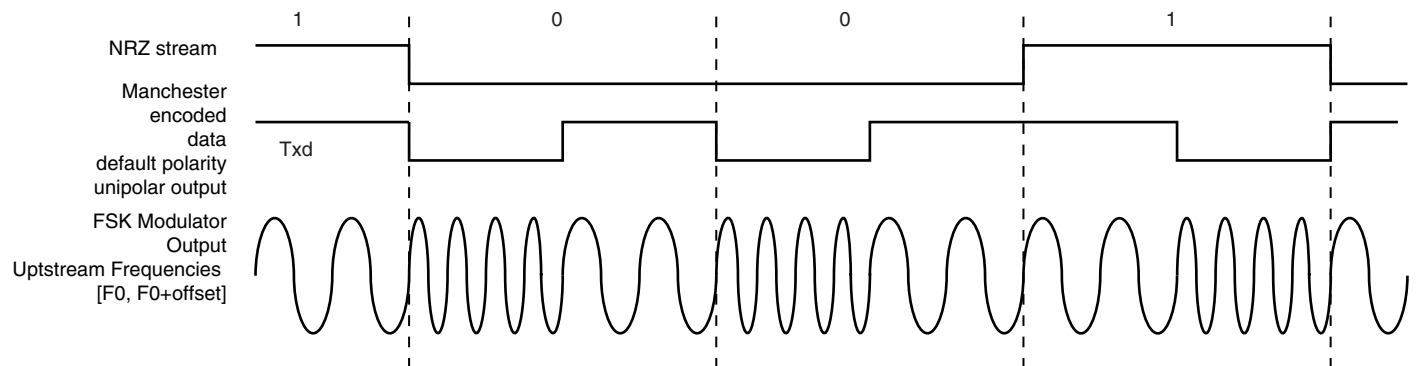

Figure 25-19. FSK Modulator Output



25.7.3.7 Synchronous Receiver

In synchronous mode (SYNC = 1), the receiver samples the RXD signal on each rising edge of the Baud Rate Clock. If a low level is detected, it is considered as a start. All data bits, the parity bit and the stop bits are sampled and the receiver waits for the next start bit. Synchronous mode operations provide a high speed transfer capability.

Configuration fields and bits are the same as in asynchronous mode.

Figure 25-20 illustrates a character reception in synchronous mode.

Figure 25-20. Synchronous Mode Character Reception

Example: 8-bit, Parity Enabled 1 Stop

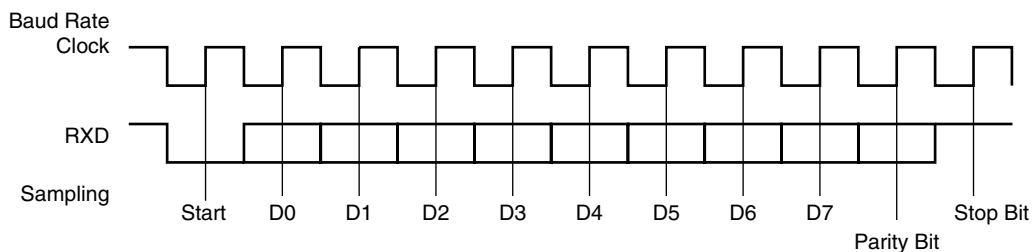

25.7.3.8 Receiver Operations

When a character reception is completed, it is transferred to the Receive Holding Register (RHR) and the RXRDY bit in the Status Register (CSR) rises. If a character is completed while the RXRDY is set, the OVRE (Overrun Error) bit is set. The last character is transferred into RHR and overwrites the previous one. The OVRE bit is cleared by writing the Control Register (CR) with the RSTSTA (Reset Status) bit at 1.

Figure 25-21. Receiver Status

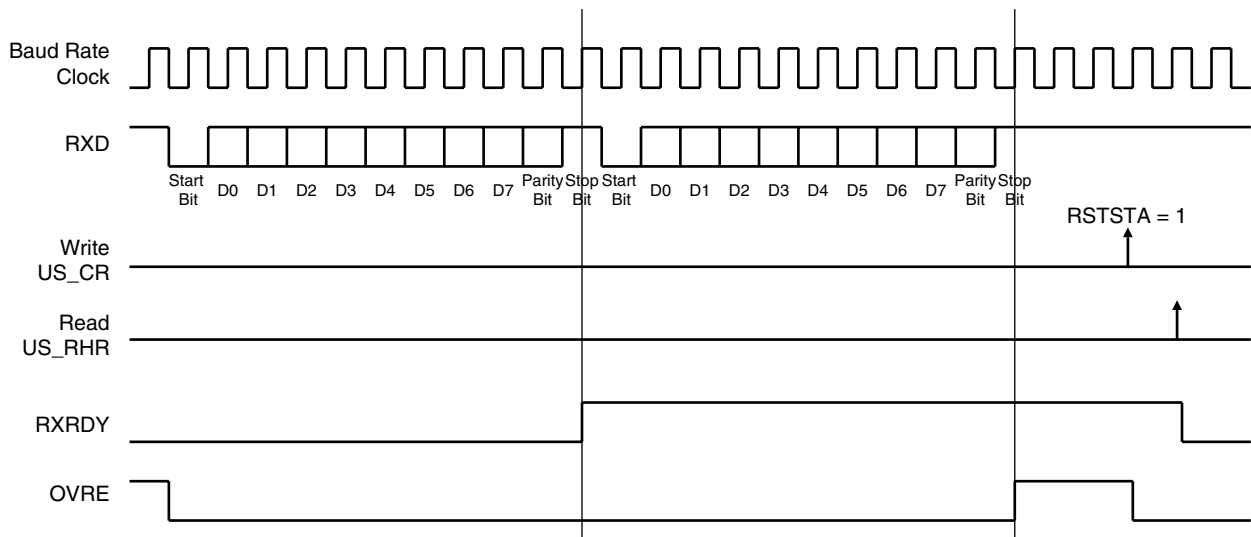

25.7.3.9 Parity

The USART supports five parity modes selected by programming the PAR field in the Mode Register (MR). The PAR field also enables the Multidrop mode, see ["Multidrop Mode" on page 400](#). Even and odd parity bit generation and error detection are supported.

If even parity is selected, the parity generator of the transmitter drives the parity bit at 0 if a number of 1s in the character data bit is even, and at 1 if the number of 1s is odd. Accordingly, the receiver parity checker counts the number of received 1s and reports a parity error if the sampled parity bit does not correspond. If odd parity is selected, the parity generator of the transmitter drives the parity bit at 1 if a number of 1s in the character data bit is even, and at 0 if the number of 1s is odd. Accordingly, the receiver parity checker counts the number of received 1s and reports a parity error if the sampled parity bit does not correspond. If the mark parity is used, the parity generator of the transmitter drives the parity bit at 1 for all characters. The receiver parity checker reports an error if the parity bit is sampled at 0. If the space parity is used, the parity generator of the transmitter drives the parity bit at 0 for all characters. The receiver parity checker reports an error if the parity bit is sampled at 1. If parity is disabled, the transmitter does not generate any parity bit and the receiver does not report any parity error.

[Table 25-6](#) shows an example of the parity bit for the character 0x41 (character ASCII "A") depending on the configuration of the USART. Because there are two bits at 1, 1 bit is added when a parity is odd, or 0 is added when a parity is even.

Table 25-6. Parity Bit Examples

Character	Hexa	Binary	Parity Bit	Parity Mode
A	0x41	0100 0001	1	Odd
A	0x41	0100 0001	0	Even
A	0x41	0100 0001	1	Mark
A	0x41	0100 0001	0	Space
A	0x41	0100 0001	None	None

When the receiver detects a parity error, it sets the PARE (Parity Error) bit in the Channel Status Register (CSR). The PARE bit can be cleared by writing the Control Register (CR) with the RST-STA bit at 1. [Figure 25-22](#) illustrates the parity bit status setting and clearing.

Figure 25-22. Parity Error

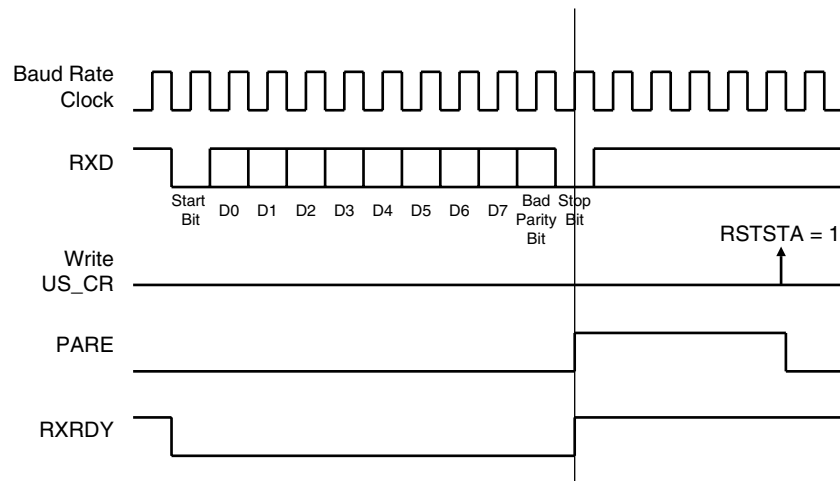

25.7.3.10 Multidrop Mode

If the PAR field in the Mode Register (MR) is programmed to the value 0x6 or 0x07, the USART runs in Multidrop Mode. This mode differentiates the data characters and the address characters. Data is transmitted with the parity bit at 0 and addresses are transmitted with the parity bit at 1.

If the USART is configured in multidrop mode, the receiver sets the PARE parity error bit when the parity bit is high and the transmitter is able to send a character with the parity bit high when the Control Register is written with the SENDA bit at 1.

To handle parity error, the PARE bit is cleared when the Control Register is written with the bit RSTSTA at 1.

The transmitter sends an address byte (parity bit set) when SENDA is written to CR. In this case, the next byte written to THR is transmitted as an address. Any character written in THR without having written the command SENDA is transmitted normally with the parity at 0.

25.7.3.11 Transmitter Timeguard

The timeguard feature enables the USART interface with slow remote devices.

The timeguard function enables the transmitter to insert an idle state on the TXD line between two characters. This idle state actually acts as a long stop bit.

The duration of the idle state is programmed in the TG field of the Transmitter Timeguard Register (TTGR). When this field is programmed at zero no timeguard is generated. Otherwise, the transmitter holds a high level on TXD after each transmitted byte during the number of bit periods programmed in TG in addition to the number of stop bits.

As illustrated in Figure 25-23, the behavior of TXRDY and TXEMPTY status bits is modified by the programming of a timeguard. TXRDY rises only when the start bit of the next character is sent, and thus remains at 0 during the timeguard transmission if a character has been written in THR. TXEMPTY remains low until the timeguard transmission is completed as the timeguard is part of the current character being transmitted.

Figure 25-23. Timeguard Operations

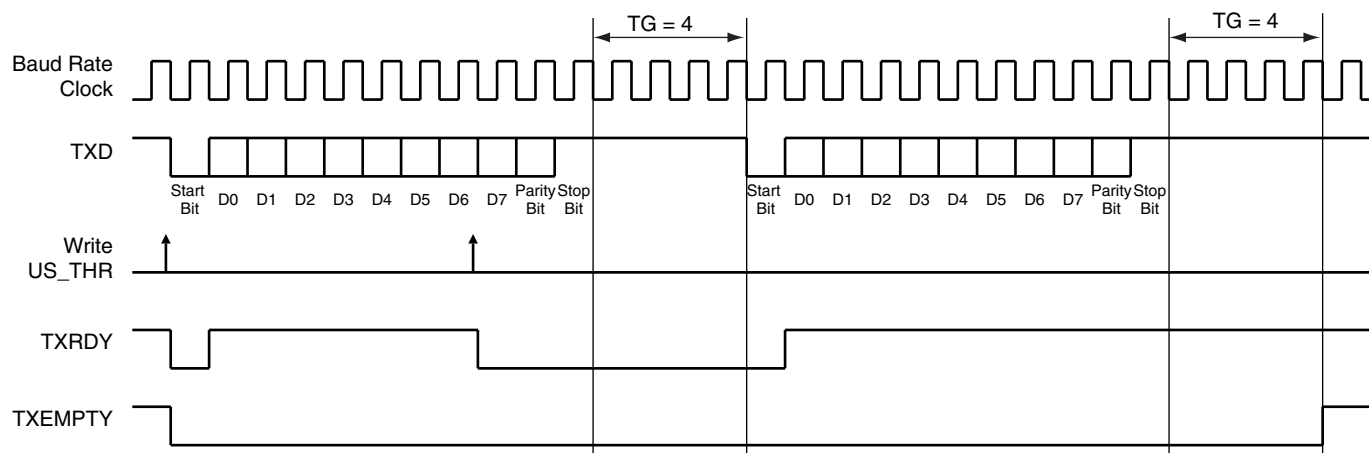

Table 25-7 indicates the maximum length of a timeguard period that the transmitter can handle in relation to the function of the Baud Rate.

Table 25-7. Maximum Timeguard Length Depending on Baud Rate

Baud Rate	Bit time	Timeguard
Bit/sec	μs	ms
1 200	833	212.50
9 600	104	26.56
14400	69.4	17.71
19200	52.1	13.28
28800	34.7	8.85
33400	29.9	7.63
56000	17.9	4.55
57600	17.4	4.43
115200	8.7	2.21

25.7.3.12 Receiver Time-out

The Receiver Time-out provides support in handling variable-length frames. This feature detects an idle condition on the RXD line. When a time-out is detected, the bit TIMEOUT in the Channel Status Register (CSR) rises and can generate an interrupt, thus indicating to the driver an end of frame.

The time-out delay period (during which the receiver waits for a new character) is programmed in the TO field of the Receiver Time-out Register (RTOR). If the TO field is programmed at 0, the Receiver Time-out is disabled and no time-out is detected. The TIMEOUT bit in CSR remains at 0. Otherwise, the receiver loads a 16-bit counter with the value programmed in TO. This counter is decremented at each bit period and reloaded each time a new character is received. If the counter reaches 0, the TIMEOUT bit in the Status Register rises.

The user can either:

- Obtain an interrupt when a time-out is detected after having received at least one character. This is performed by writing the Control Register (CR) with the STTTO (Start Time-out) bit at 1.
- Obtain a periodic interrupt while no character is received. This is performed by writing CR with the RETTO (Reload and Start Time-out) bit at 1.

If STTTO is performed, the counter clock is stopped until a first character is received. The idle state on RXD before the start of the frame does not provide a time-out. This prevents having to obtain a periodic interrupt and enables a wait of the end of frame when the idle state on RXD is detected.

If RETTO is performed, the counter starts counting down immediately from the value TO. This enables generation of a periodic interrupt so that a user time-out can be handled, for example when no key is pressed on a keyboard.

Figure 25-24 shows the block diagram of the Receiver Time-out feature.

Figure 25-24. Receiver Time-out Block Diagram

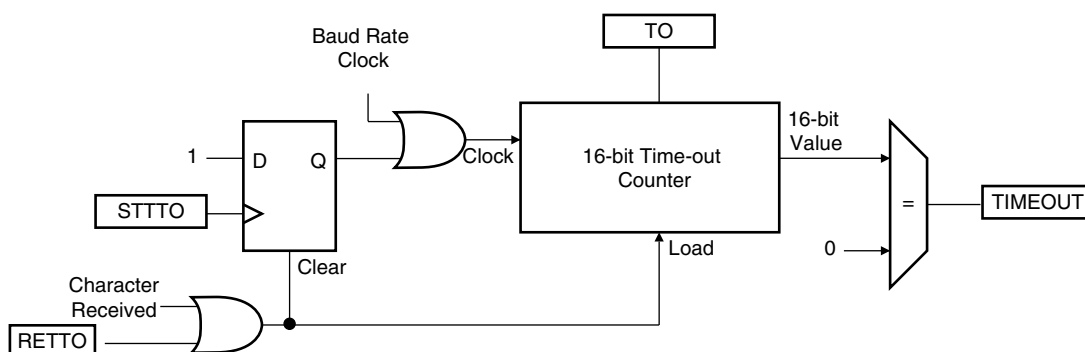

Table 25-8 gives the maximum time-out period for some standard baud rates.

Table 25-8. Maximum Time-out Period

Baud Rate	Bit Time	Time-out
bit/sec	μs	ms
600	1 667	109 225
1 200	833	54 613
2 400	417	27 306
4 800	208	13 653
9 600	104	6 827
14400	69	4 551
19200	52	3 413
28800	35	2 276
33400	30	1 962
56000	18	1 170
57600	17	1 138
200000	5	328

25.7.3.13 Framing Error

The receiver is capable of detecting framing errors. A framing error happens when the stop bit of a received character is detected at level 0. This can occur if the receiver and the transmitter are fully desynchronized.

A framing error is reported on the FRAME bit of the Channel Status Register (CSR). The FRAME bit is asserted in the middle of the stop bit as soon as the framing error is detected. It is cleared by writing the Control Register (CR) with the RSTSTA bit at 1.

Figure 25-25. Framing Error Status

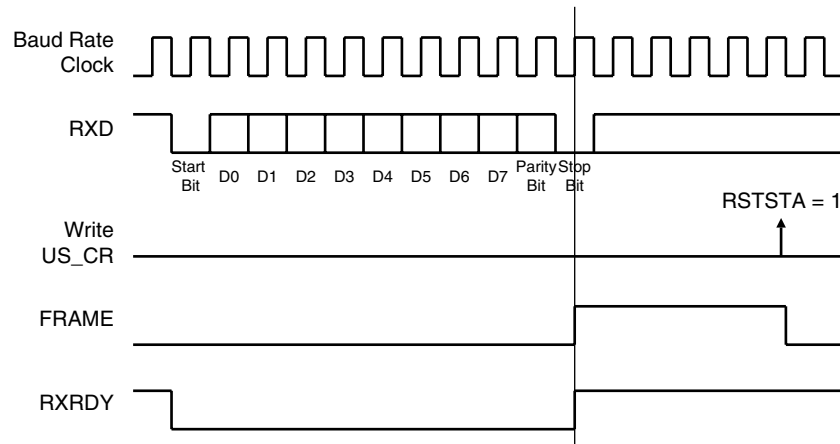

25.7.3.14 Transmit Break

The user can request the transmitter to generate a break condition on the TXD line. A break condition drives the TXD line low during at least one complete character. It appears the same as a 0x00 character sent with the parity and the stop bits at 0. However, the transmitter holds the TXD line at least during one character until the user requests the break condition to be removed.

A break is transmitted by writing the Control Register (CR) with the STTBRK bit at 1. This can be performed at any time, either while the transmitter is empty (no character in either the Shift Register or in THR) or when a character is being transmitted. If a break is requested while a character is being shifted out, the character is first completed before the TXD line is held low.

Once STTBRK command is requested further STTBRK commands are ignored until the end of the break is completed.

The break condition is removed by writing CR with the STPBRK bit at 1. If the STPBRK is requested before the end of the minimum break duration (one character, including start, data, parity and stop bits), the transmitter ensures that the break condition completes.

The transmitter considers the break as though it is a character, i.e. the STTBRK and STPBRK commands are taken into account only if the TXRDY bit in CSR is at 1 and the start of the break condition clears the TXRDY and TXEMPTY bits as if a character is processed.

Writing CR with the both STTBRK and STPBRK bits at 1 can lead to an unpredictable result. All STPBRK commands requested without a previous STTBRK command are ignored. A byte written into the Transmit Holding Register while a break is pending, but not started, is ignored.

After the break condition, the transmitter returns the TXD line to 1 for a minimum of 12 bit times. Thus, the transmitter ensures that the remote receiver detects correctly the end of break and the start of the next character. If the timeguard is programmed with a value higher than 12, the TXD line is held high for the timeguard period.

After holding the TXD line for this period, the transmitter resumes normal operations.

Figure 25-26 illustrates the effect of both the Start Break (STTBK) and Stop Break (STPBK) commands on the TXD line.

Figure 25-26. Break Transmission

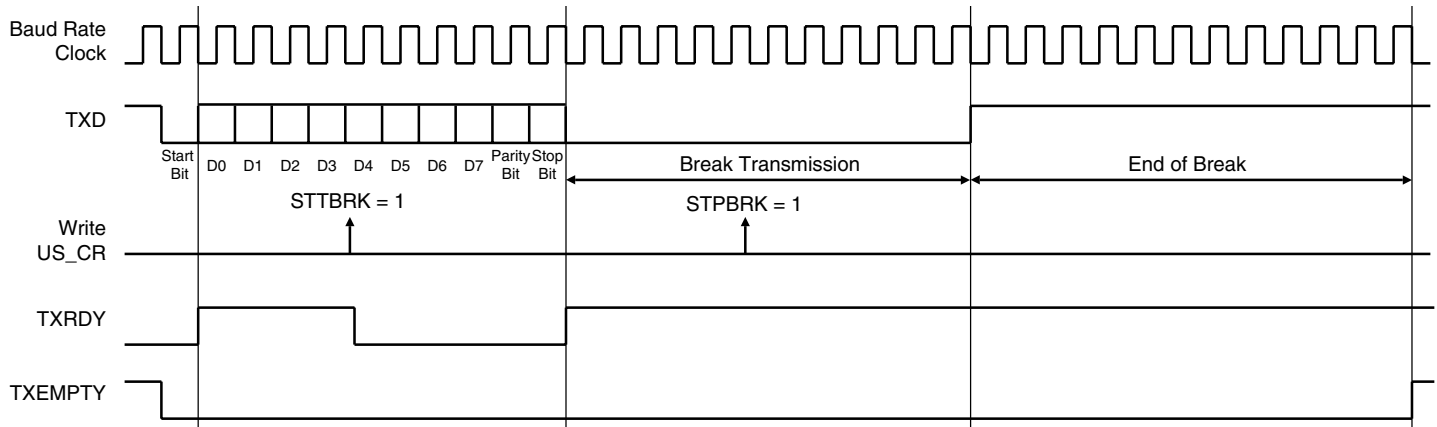

25.7.3.15 Receive Break

The receiver detects a break condition when all data, parity and stop bits are low. This corresponds to detecting a framing error with data at 0x00, but FRAME remains low.

When the low stop bit is detected, the receiver asserts the RXBRK bit in CSR. This bit may be cleared by writing the Control Register (CR) with the bit RSTSTA at 1.

An end of receive break is detected by a high level for at least 2/16 of a bit period in asynchronous operating mode or one sample at high level in synchronous operating mode. The end of break detection also asserts the RXBRK bit.

25.7.3.16 Hardware Handshaking

The USART features a hardware handshaking out-of-band flow control. The RTS and CTS pins are used to connect with the remote device, as shown in Figure 25-27.

Figure 25-27. Connection with a Remote Device for Hardware Handshaking

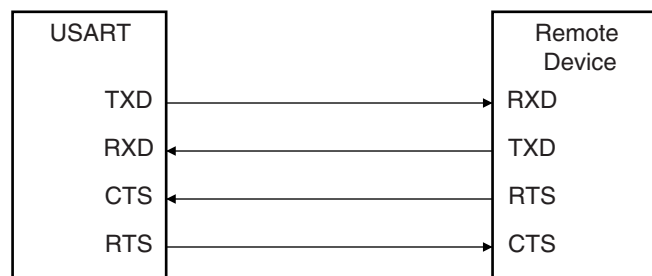

Setting the USART to operate with hardware handshaking is performed by writing the MODE field in the Mode Register (MR) to the value 0x2.

The USART behavior when hardware handshaking is enabled is the same as the behavior in standard synchronous or asynchronous mode, except that the receiver drives the RTS pin as described below and the level on the CTS pin modifies the behavior of the transmitter as described below. Using this mode requires using the PDC channel for reception. The transmitter can handle hardware handshaking in any case.

Figure 25-28 shows how the receiver operates if hardware handshaking is enabled. The RTS pin is driven high if the receiver is disabled and if the status RXBUFF (Receive Buffer Full) coming from the PDC channel is high. Normally, the remote device does not start transmitting while its CTS pin (driven by RTS) is high. As soon as the Receiver is enabled, the RTS falls, indicating to the remote device that it can start transmitting. Defining a new buffer to the PDC clears the status bit RXBUFF and, as a result, asserts the pin RTS low.

Figure 25-28. Receiver Behavior when Operating with Hardware Handshaking

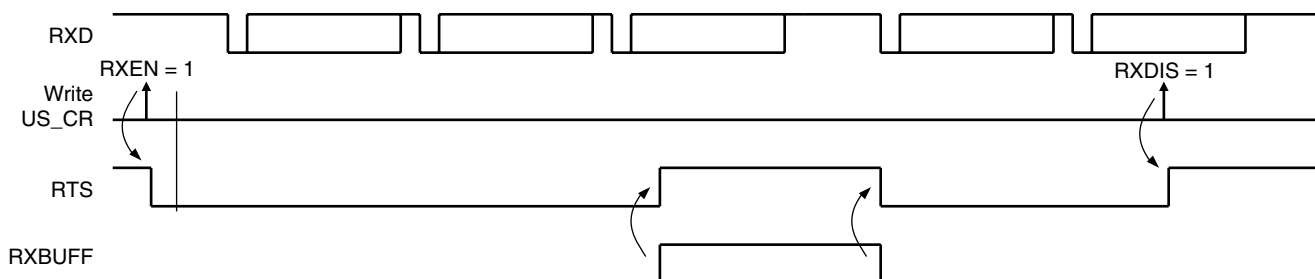

Figure 25-29 shows how the transmitter operates if hardware handshaking is enabled. The CTS pin disables the transmitter. If a character is being processing, the transmitter is disabled only after the completion of the current character and transmission of the next character happens as soon as the pin CTS falls.

Figure 25-29. Transmitter Behavior when Operating with Hardware Handshaking



25.7.4 ISO7816 Mode

The USART features an ISO7816-compatible operating mode. This mode permits interfacing with smart cards and Security Access Modules (SAM) communicating through an ISO7816 link. Both T = 0 and T = 1 protocols defined by the ISO7816 specification are supported.

Setting the USART in ISO7816 mode is performed by writing the MODE field in the Mode Register (MR) to the value 0x4 for protocol T = 0 and to the value 0x5 for protocol T = 1.

25.7.4.1 ISO7816 Mode Overview

The ISO7816 is a half duplex communication on only one bidirectional line. The baud rate is determined by a division of the clock provided to the remote device (see ["Baud Rate Generator" on page 384](#)).

The USART connects to a smart card as shown in [Figure 25-30](#). The TXD line becomes bidirectional and the Baud Rate Generator feeds the ISO7816 clock on the SCK pin. As the TXD pin becomes bidirectional, its output remains driven by the output of the transmitter but only when the transmitter is active while its input is directed to the input of the receiver. The USART is considered as the master of the communication as it generates the clock.

Figure 25-30. Connection of a Smart Card to the USART

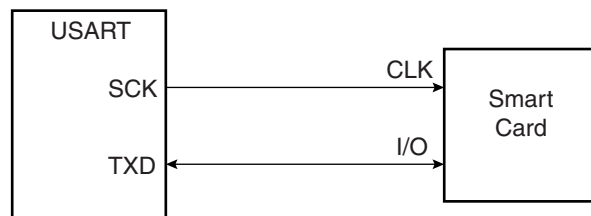

When operating in ISO7816, either in $T = 0$ or $T = 1$ modes, the character format is fixed. The configuration is 8 data bits, even parity and 1 or 2 stop bits, regardless of the values programmed in the CHRL, MODE9, PAR and CHMODE fields. MSBF can be used to transmit LSB or MSB first. Parity Bit (PAR) can be used to transmit in normal or inverse mode. Refer to ["USART Mode Register" on page 417](#) and ["PAR: Parity Type" on page 418](#).

The USART cannot operate concurrently in both receiver and transmitter modes as the communication is unidirectional at a time. It has to be configured according to the required mode by enabling or disabling either the receiver or the transmitter as desired. Enabling both the receiver and the transmitter at the same time in ISO7816 mode may lead to unpredictable results.

The ISO7816 specification defines an inverse transmission format. Data bits of the character must be transmitted on the I/O line at their negative value. The USART does not support this format and the user has to perform an exclusive OR on the data before writing it in the Transmit Holding Register (THR) or after reading it in the Receive Holding Register (RHR).

25.7.4.2 Protocol $T = 0$

In $T = 0$ protocol, a character is made up of one start bit, eight data bits, one parity bit and one guard time, which lasts two bit times. The transmitter shifts out the bits and does not drive the I/O line during the guard time.

If no parity error is detected, the I/O line remains at 1 during the guard time and the transmitter can continue with the transmission of the next character, as shown in [Figure 25-31](#).

If a parity error is detected by the receiver, it drives the I/O line at 0 during the guard time, as shown in [Figure 25-32](#). This error bit is also named NACK, for Non Acknowledge. In this case, the character lasts 1 bit time more, as the guard time length is the same and is added to the error bit time which lasts 1 bit time.

When the USART is the receiver and it detects an error, it does not load the erroneous character in the Receive Holding Register (RHR). It appropriately sets the PARE bit in the Status Register (SR) so that the software can handle the error.

Figure 25-31. T = 0 Protocol without Parity Error

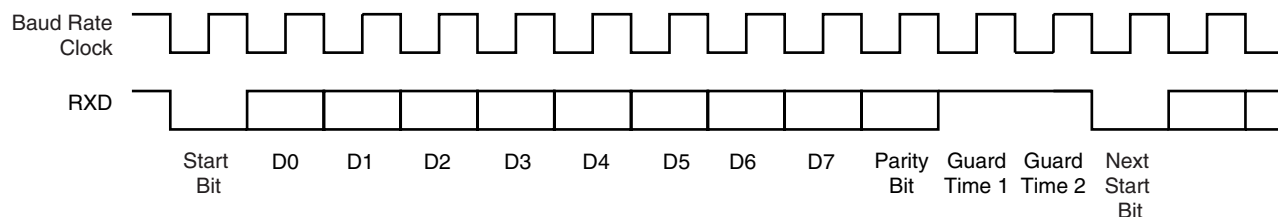
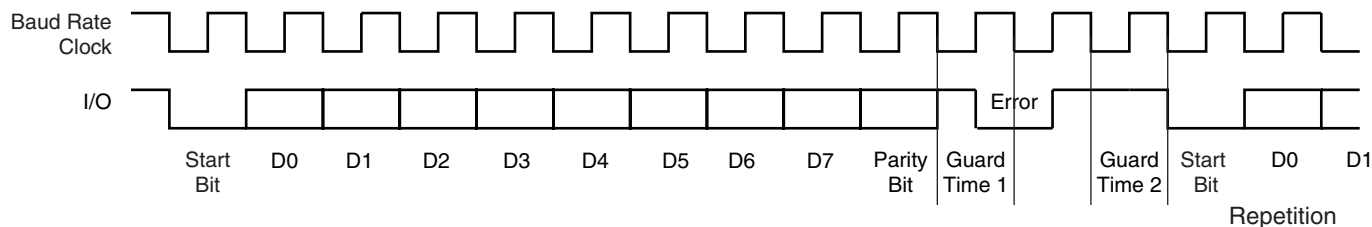

Figure 25-32. T = 0 Protocol with Parity Error



25.7.4.3 Receive Error Counter

The USART receiver also records the total number of errors. This can be read in the Number of Error (NER) register. The NB_ERRORS field can record up to 255 errors. Reading NER automatically clears the NB_ERRORS field.

25.7.4.4 Receive NACK Inhibit

The USART can also be configured to inhibit an error. This can be achieved by setting the INACK bit in the Mode Register (MR). If INACK is at 1, no error signal is driven on the I/O line even if a parity bit is detected, but the INACK bit is set in the Status Register (SR). The INACK bit can be cleared by writing the Control Register (CR) with the RSTNACK bit at 1.

Moreover, if INACK is set, the erroneous received character is stored in the Receive Holding Register, as if no error occurred. However, the RXRDY bit does not raise.

25.7.4.5 Transmit Character Repetition

When the USART is transmitting a character and gets a NACK, it can automatically repeat the character before moving on to the next one. Repetition is enabled by writing the MAX_ITERATION field in the Mode Register (MR) at a value higher than 0. Each character can be transmitted up to eight times; the first transmission plus seven repetitions.

If MAX_ITERATION does not equal zero, the USART repeats the character as many times as the value loaded in MAX_ITERATION.

When the USART repetition number reaches MAX_ITERATION, the ITERATION bit is set in the Channel Status Register (CSR). If the repetition of the character is acknowledged by the receiver, the repetitions are stopped and the iteration counter is cleared.

The ITERATION bit in CSR can be cleared by writing the Control Register with the RSIT bit at 1.

25.7.4.6 Disable Successive Receive NACK

The receiver can limit the number of successive NACKs sent back to the remote transmitter. This is programmed by setting the bit DSNACK in the Mode Register (MR). The maximum number of NACK transmitted is programmed in the MAX_ITERATION field. As soon as

MAX_ITERATION is reached, the character is considered as correct, an acknowledge is sent on the line and the ITERATION bit in the Channel Status Register is set.

25.7.4.7 Protocol T = 1

When operating in ISO7816 protocol T = 1, the transmission is similar to an asynchronous format with only one stop bit. The parity is generated when transmitting and checked when receiving. Parity error detection sets the PARE bit in the Channel Status Register (CSR).

25.7.5 IrDA Mode

The USART features an IrDA mode supplying half-duplex point-to-point wireless communication. It embeds the modulator and demodulator which allows a glueless connection to the infrared transceivers, as shown in [Figure 25-33](#). The modulator and demodulator are compliant with the IrDA specification version 1.1 and support data transfer speeds ranging from 2.4 Kb/s to 115.2 Kb/s.

The USART IrDA mode is enabled by setting the MODE field in the Mode Register (MR) to the value 0x8. The IrDA Filter Register (IF) allows configuring the demodulator filter. The USART transmitter and receiver operate in a normal asynchronous mode and all parameters are accessible. Note that the modulator and the demodulator are activated.

Figure 25-33. Connection to IrDA Transceivers

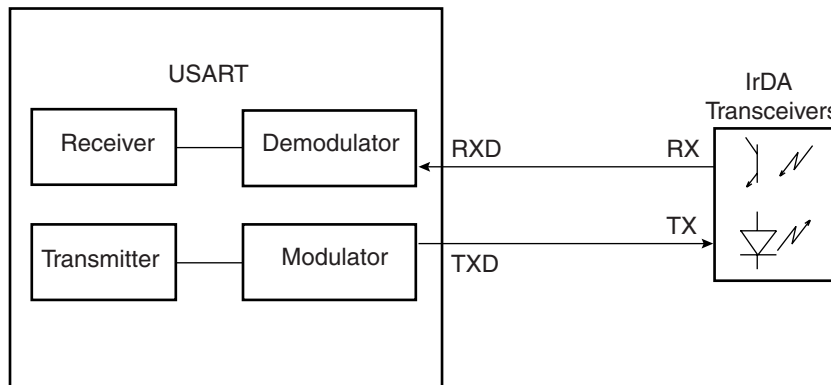

The receiver and the transmitter must be enabled or disabled according to the direction of the transmission to be managed.

25.7.5.1 IrDA Modulation

For baud rates up to and including 115.2 Kbits/sec, the RZI modulation scheme is used. “0” is represented by a light pulse of 3/16th of a bit time. Some examples of signal pulse duration are shown in [Table 25-9](#).

Table 25-9. IrDA Pulse Duration

Baud Rate	Pulse Duration (3/16)
2.4 Kb/s	78.13 μs
9.6 Kb/s	19.53 μs
19.2 Kb/s	9.77 μs

Table 25-9. IrDA Pulse Duration

Baud Rate	Pulse Duration (3/16)
38.4 Kb/s	4.88 μs
57.6 Kb/s	3.26 μs
115.2 Kb/s	1.63 μs

Figure 25-34 shows an example of character transmission.

Figure 25-34. IrDA Modulation

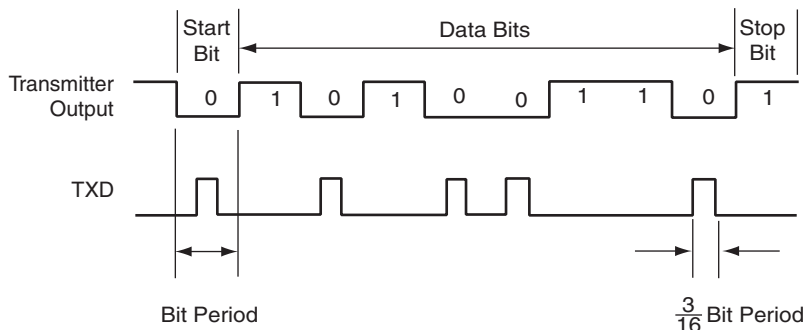

25.7.5.2 IrDA Baud Rate

Table 25-10 gives some examples of CD values, baud rate error and pulse duration. Note that the requirement on the maximum acceptable error of $\pm 1.87\%$ must be met.

Table 25-10. IrDA Baud Rate Error

Peripheral Clock	Baud Rate	CD	Baud Rate Error	Pulse Time
3 686 400	115 200	2	0.00%	1.63
20 000 000	115 200	11	1.38%	1.63
32 768 000	115 200	18	1.25%	1.63
40 000 000	115 200	22	1.38%	1.63
3 686 400	57 600	4	0.00%	3.26
20 000 000	57 600	22	1.38%	3.26
32 768 000	57 600	36	1.25%	3.26
40 000 000	57 600	43	0.93%	3.26
3 686 400	38 400	6	0.00%	4.88
20 000 000	38 400	33	1.38%	4.88
32 768 000	38 400	53	0.63%	4.88
40 000 000	38 400	65	0.16%	4.88
3 686 400	19 200	12	0.00%	9.77
20 000 000	19 200	65	0.16%	9.77
32 768 000	19 200	107	0.31%	9.77
40 000 000	19 200	130	0.16%	9.77

Table 25-10. IrDA Baud Rate Error (Continued)

Peripheral Clock	Baud Rate	CD	Baud Rate Error	Pulse Time
3 686 400	9 600	24	0.00%	19.53
20 000 000	9 600	130	0.16%	19.53
32 768 000	9 600	213	0.16%	19.53
40 000 000	9 600	260	0.16%	19.53
3 686 400	2 400	96	0.00%	78.13
20 000 000	2 400	521	0.03%	78.13
32 768 000	2 400	853	0.04%	78.13

25.7.5.3 IrDA Demodulator

The demodulator is based on the IrDA Receive filter comprised of an 8-bit down counter which is loaded with the value programmed in IF. When a falling edge is detected on the RXD pin, the Filter Counter starts counting down at the Master Clock (MCK) speed. If a rising edge is detected on the RXD pin, the counter stops and is reloaded with IF. If no rising edge is detected when the counter reaches 0, the input of the receiver is driven low during one bit time.

Figure 25-35 illustrates the operations of the IrDA demodulator.

Figure 25-35. IrDA Demodulator Operations

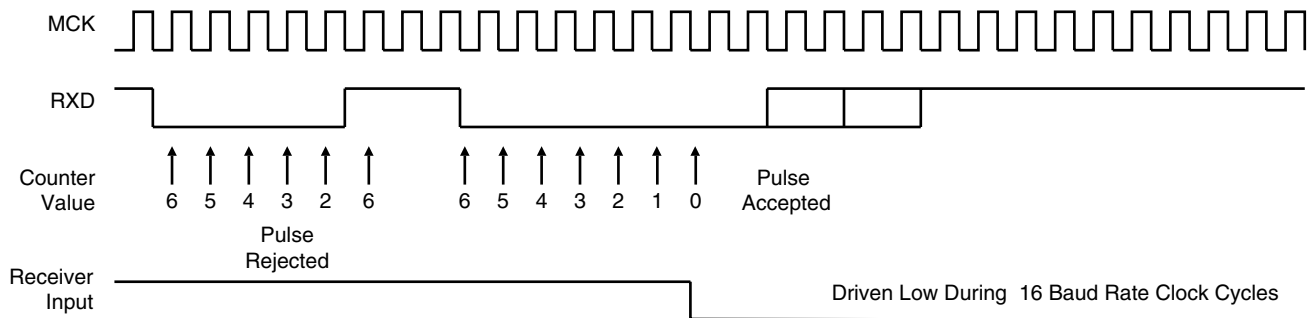

As the IrDA mode uses the same logic as the ISO7816, note that the FI_DI_RATIO field in FIDI must be set to a value higher than 0 in order to assure IrDA communications operate correctly.

25.7.6 RS485 Mode

The USART features the RS485 mode to enable line driver control. While operating in RS485 mode, the USART behaves as though in asynchronous or synchronous mode and configuration of all the parameters is possible. The difference is that the RTS pin is driven high when the transmitter is operating. The behavior of the RTS pin is controlled by the TXEMPTY bit. A typical connection of the USART to a RS485 bus is shown in [Figure 25-36](#).

Figure 25-36. Typical Connection to a RS485 Bus

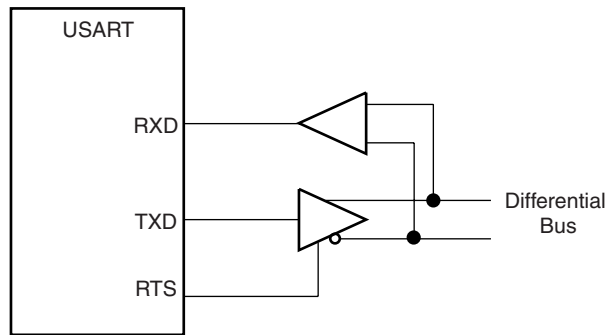

The USART is set in RS485 mode by programming the MODE field in the Mode Register (MR) to the value 0x1.

The RTS pin is at a level inverse to the TXEMPTY bit. Significantly, the RTS pin remains high when a timeguard is programmed so that the line can remain driven after the last character completion. [Figure 25-37](#) gives an example of the RTS waveform during a character transmission when the timeguard is enabled.

Figure 25-37. Example of RTS Drive with Timeguard

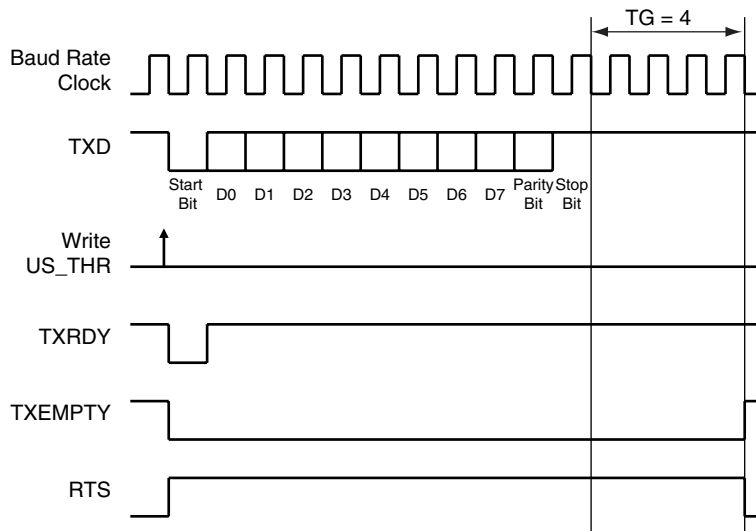

25.7.7 Test Modes

The USART can be programmed to operate in three different test modes. The internal loopback capability allows on-board diagnostics. In the loopback mode the USART interface pins are disconnected or not and reconfigured for loopback internally or externally.

25.7.7.1 Normal Mode

Normal mode connects the RXD pin on the receiver input and the transmitter output on the TXD pin.

Figure 25-38. Normal Mode Configuration

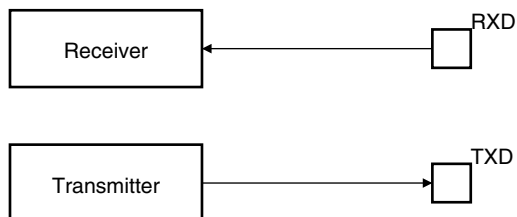

25.7.7.2 Automatic Echo Mode

Automatic echo mode allows bit-by-bit retransmission. When a bit is received on the RXD pin, it is sent to the TXD pin, as shown in [Figure 25-39](#). Programming the transmitter has no effect on the TXD pin. The RXD pin is still connected to the receiver input, thus the receiver remains active.

Figure 25-39. Automatic Echo Mode Configuration

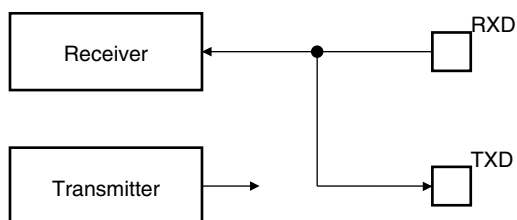

25.7.7.3 Local Loopback Mode

Local loopback mode connects the output of the transmitter directly to the input of the receiver, as shown in [Figure 25-40](#). The TXD and RXD pins are not used. The RXD pin has no effect on the receiver and the TXD pin is continuously driven high, as in idle state.

Figure 25-40. Local Loopback Mode Configuration

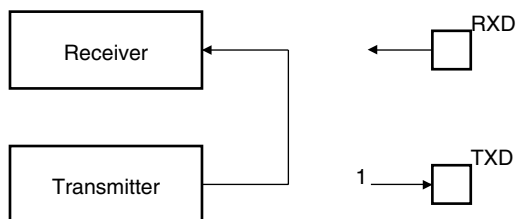

25.7.7.4 Remote Loopback Mode

Remote loopback mode directly connects the RXD pin to the TXD pin, as shown in [Figure 25-41](#). The transmitter and the receiver are disabled and have no effect. This mode allows bit-by-bit retransmission.

Figure 25-41. Remote Loopback Mode Configuration

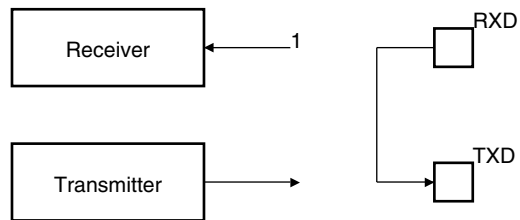

25.8 USART User Interface

Table 25-11. USART Memory Map

Offset	Register	Name	Access	Reset State
0x0000	Control Register	CR	Write-only	–
0x0004	Mode Register	MR	Read/Write	–
0x0008	Interrupt Enable Register	IER	Write-only	–
0x000C	Interrupt Disable Register	IDR	Write-only	–
0x0010	Interrupt Mask Register	IMR	Read-only	0x0
0x0014	Channel Status Register	CSR	Read-only	–
0x0018	Receiver Holding Register	RHR	Read-only	0x0
0x001C	Transmitter Holding Register	THR	Write-only	–
0x0020	Baud Rate Generator Register	BRGR	Read/Write	0x0
0x0024	Receiver Time-out Register	RTOR	Read/Write	0x0
0x0028	Transmitter Timeguard Register	TTGR	Read/Write	0x0
0x2C - 0x3C	Reserved	–	–	–
0x0040	FI DI Ratio Register	FIDI	Read/Write	0x174
0x0044	Number of Errors Register	NER	Read-only	–
0x0048	Reserved	-	–	–
0x004C	IrDA Filter Register	IF	Read/Write	0x0
0x0050	Manchester Encoder Decoder Register	MAN	Read/Write	0x30011004
0x100 - 0x128	Reserved for PDC Registers	–	–	–

25.8.1 USART Control Register

Name: CR

Access Type: Write-only

31	30	29	28	27	26	25	24
–	–	–	–	–	–	–	–
23	22	21	20	19	18	17	16
–	–	–	–	RTSDIS	RTSEN	–	–
15	14	13	12	11	10	9	8
RETTO	RSTNACK	RSTIT	SENDA	STTTO	STPBRK	STTBRK	RSTSTA
7	6	5	4	3	2	1	0
TXDIS	TXEN	RXDIS	RXEN	RSTTX	RSTRX	–	–

- **RSTRX: Reset Receiver**

0: No effect.

1: Resets the receiver.

- **RSTTX: Reset Transmitter**

0: No effect.

1: Resets the transmitter.

- **RXEN: Receiver Enable**

0: No effect.

1: Enables the receiver, if RXDIS is 0.

- **RXDIS: Receiver Disable**

0: No effect.

1: Disables the receiver.

- **TXEN: Transmitter Enable**

0: No effect.

1: Enables the transmitter if TXDIS is 0.

- **TXDIS: Transmitter Disable**

0: No effect.

1: Disables the transmitter.

- **RSTSTA: Reset Status Bits**

0: No effect.

1: Resets the status bits PARE, FRAME, OVRE, MANERR and RXBRK in CSR.

- **STTBRK: Start Break**

0: No effect.

1: Starts transmission of a break after the characters present in THR and the Transmit Shift Register have been transmitted. No effect if a break is already being transmitted.

- **STPBRK: Stop Break**

0: No effect.

1: Stops transmission of the break after a minimum of one character length and transmits a high level during 12-bit periods. No effect if no break is being transmitted.

- **STTTO: Start Time-out**

0: No effect

1: Starts waiting for a character before clocking the time-out counter.

- **SENDA: Send Address**

0: No effect.

1: In Multidrop Mode only, the next character written to the THR is sent with the address bit set.

- **RSTIT: Reset Iterations**

0: No effect.

1: Resets ITERATION in CSR. No effect if the ISO7816 is not enabled.

- **RSTNACK: Reset Non Acknowledge**

0: No effect

1: Resets NACK in CSR.

- **RETTO: Rearm Time-out**

0: No effect

1: Restart Time-out

- **RTSEN: Request to Send Enable**

0: No effect.

1: Drives the pin RTS to 0.

- **RTSDIS: Request to Send Disable**

0: No effect.

1: Drives the pin RTS to 1.

25.8.2 USART Mode Register

Name: MR

Access Type: Read/Write

31	30	29	28	27	26	25	24
ONEBIT	MODSYNC-	MAN	FILTER	-	MAX_ITERATION		
23	22	21	20	19	18	17	16
-	VAR_SYNC	DSNACK	INACK	OVER	CLKO	MODE9	MSBF
15	14	13	12	11	10	9	8
CHMODE		NBSTOP		PAR			SYNC
7	6	5	4	3	2	1	0
CHRL		USCLKS		MODE			

• MODE

MODE				Mode of the USART
0	0	0	0	Normal
0	0	0	1	RS485
0	0	1	0	Hardware Handshaking
0	0	1	1	Reserved
0	1	0	0	ISO7816 Protocol: T = 0
0	1	0	1	Reserved
0	1	1	0	ISO7816 Protocol: T = 1
0	1	1	1	Reserved
1	0	0	0	IrDA
1	1	x	x	Reserved

• USCLKS: Clock Selection

USCLKS		Selected Clock
0	0	MCK
0	1	MCK / DIV
1	0	Reserved
1	1	SCK

• CHRL: Character Length.

CHRL		Character Length
0	0	5 bits

0	1	6 bits
1	0	7 bits
1	1	8 bits

- **SYNC: Synchronous Mode Select**

0: USART operates in Asynchronous Mode.

1: USART operates in Synchronous Mode.

- **PAR: Parity Type**

PAR			Parity Type
0	0	0	Even parity
0	0	1	Odd parity
0	1	0	Parity forced to 0 (Space)
0	1	1	Parity forced to 1 (Mark)
1	0	x	No parity
1	1	x	Multidrop mode

- **NBSTOP: Number of Stop Bits**

NBSTOP		Asynchronous (SYNC = 0)	Synchronous (SYNC = 1)
0	0	1 stop bit	1 stop bit
0	1	1.5 stop bits	Reserved
1	0	2 stop bits	2 stop bits
1	1	Reserved	Reserved

- **CHMODE: Channel Mode**

CHMODE		Mode Description
0	0	Normal Mode
0	1	Automatic Echo. Receiver input is connected to the TXD pin.
1	0	Local Loopback. Transmitter output is connected to the Receiver Input..
1	1	Remote Loopback. RXD pin is internally connected to the TXD pin.

- **MSBF: Bit Order**

0: Least Significant Bit is sent/received first.

1: Most Significant Bit is sent/received first.

- **MODE9: 9-bit Character Length**

0: CHRL defines character length.

1: 9-bit character length.

- **CKLO: Clock Output Select**

0: The USART does not drive the SCK pin.

1: The USART drives the SCK pin if USCLKS does not select the external clock SCK.

- **OVER: Oversampling Mode**

0: 16x Oversampling.

1: 8x Oversampling.

- **INACK: Inhibit Non Acknowledge**

0: The NACK is generated.

1: The NACK is not generated.

- **DSNACK: Disable Successive NACK**

0: NACK is sent on the ISO line as soon as a parity error occurs in the received character (unless INACK is set).

1: Successive parity errors are counted up to the value specified in the MAX_ITERATION field. These parity errors generate a NACK on the ISO line. As soon as this value is reached, no additional NACK is sent on the ISO line. The flag ITERATION is asserted.

- **VAR_SYNC: Variable synchronization of command/data sync Start Frame Delimiter**

0: User defined configuration of command or data sync field depending on SYNC value.

1: The sync field is updated when a character is written into THR register.

- **MAX_ITERATION**

Defines the maximum number of iterations in mode ISO7816, protocol T= 0.

- **FILTER: Infrared Receive Line Filter**

0: The USART does not filter the receive line.

1: The USART filters the receive line using a three-sample filter (1/16-bit clock) (2 over 3 majority).

- **MAN: Manchester Encoder/Decoder Enable**

0: Manchester Encoder/Decoder are disabled.

1: Manchester Encoder/Decoder are enabled.

- **MODSYNC: Manchester Synchronization mode**

0: The Manchester Start bit is a 0 to 1 transition

1: The Manchester Start bit is a 1 to 0 transition.

- **ONEBIT: Start Frame Delimiter selector**

0: Start Frame delimiter is COMMAND or DATA SYNC.

1: Start Frame delimiter is One Bit.

25.8.3 USART Interrupt Enable Register

Name: IER

Access Type: Write-only

31	30	29	28	27	26	25	24
–	–	–	–	–	–	–	–
23	22	21	20	19	18	17	16
–	–	–	MANE	CTSIC	–	–	–
15	14	13	12	11	10	9	8
–	–	NACK	RXBUFF	TXBUFE	ITERATION	TXEMPTY	TIMEOUT
7	6	5	4	3	2	1	0
PARE	FRAME	OVRE	ENDTX	ENDRX	RXBRK	TXRDY	RXRDY

- **RXRDY:** RXRDY Interrupt Enable
- **TXRDY:** TXRDY Interrupt Enable
- **RXBRK:** Receiver Break Interrupt Enable
- **ENDRX:** End of Receive Transfer Interrupt Enable
- **ENDTX:** End of Transmit Interrupt Enable
- **OVRE:** Overrun Error Interrupt Enable
- **FRAME:** Framing Error Interrupt Enable
- **PARE:** Parity Error Interrupt Enable
- **TIMEOUT:** Time-out Interrupt Enable
- **TXEMPTY:** TXEMPTY Interrupt Enable
- **ITERATION:** Iteration Interrupt Enable
- **TXBUFE:** Buffer Empty Interrupt Enable
- **RXBUFF:** Buffer Full Interrupt Enable
- **NACK:** Non Acknowledge Interrupt Enable
- **CTSIC:** Clear to Send Input Change Interrupt Enable
- **MANE:** Manchester Error Interrupt Enable

0: No effect.

1: Enables the corresponding interrupt.

25.8.4 USART Interrupt Disable Register

Name: IDR

Access Type: Write-only

31	30	29	28	27	26	25	24
–	–	–	–	–	–	–	–
23	22	21	20	19	18	17	16
–	–	–	MANE	CTSIC	–	–	–
15	14	13	12	11	10	9	8
–	–	NACK	RXBUFF	TXBUFE	ITERATION	TXEMPTY	TIMEOUT
7	6	5	4	3	2	1	0
PARE	FRAME	OVRE	ENDTX	ENDRX	RXBRK	TXRDY	RXRDY

- **RXRDY:** RXRDY Interrupt Disable
- **TXRDY:** TXRDY Interrupt Disable
- **RXBRK:** Receiver Break Interrupt Disable
- **ENDRX:** End of Receive Transfer Interrupt Disable
- **ENDTX:** End of Transmit Interrupt Disable
- **OVRE:** Overrun Error Interrupt Disable
- **FRAME:** Framing Error Interrupt Disable
- **PARE:** Parity Error Interrupt Disable
- **TIMEOUT:** Time-out Interrupt Disable
- **TXEMPTY:** TXEMPTY Interrupt Disable
- **ITERATION:** Iteration Interrupt Disable
- **TXBUFE:** Buffer Empty Interrupt Disable
- **RXBUFF:** Buffer Full Interrupt Disable
- **NACK:** Non Acknowledge Interrupt Disable
- **CTSIC:** Clear to Send Input Change Interrupt Disable
- **MANE:** Manchester Error Interrupt Disable

0: No effect.

1: Disables the corresponding interrupt.

25.8.5 USART Interrupt Mask Register

Name: IMR

Access Type: Read-only

31	30	29	28	27	26	25	24
–	–	–	–	–	–	–	–
23	22	21	20	19	18	17	16
–	–	–	MANE	CTSIC	–	–	–
15	14	13	12	11	10	9	8
–	–	NACK	RXBUFF	TXBUFE	ITERATION	TXEMPTY	TIMEOUT
7	6	5	4	3	2	1	0
PARE	FRAME	OVRE	ENDTX	ENDRX	RXBRK	TXRDY	RXRDY

- **RXRDY: RXRDY Interrupt Mask**
- **TXRDY: TXRDY Interrupt Mask**
- **RXBRK: Receiver Break Interrupt Mask**
- **ENDRX: End of Receive Transfer Interrupt Mask**
- **ENDTX: End of Transmit Interrupt Mask**
- **OVRE: Overrun Error Interrupt Mask**
- **FRAME: Framing Error Interrupt Mask**
- **PARE: Parity Error Interrupt Mask**
- **TIMEOUT: Time-out Interrupt Mask**
- **TXEMPTY: TXEMPTY Interrupt Mask**
- **ITERATION: Iteration Interrupt Mask**
- **TXBUFE: Buffer Empty Interrupt Mask**
- **RXBUFF: Buffer Full Interrupt Mask**
- **NACK: Non Acknowledge Interrupt Mask**
- **CTSIC: Clear to Send Input Change Interrupt Mask**
- **MANE: Manchester Error Interrupt Mask**

0: The corresponding interrupt is disabled.

1: The corresponding interrupt is enabled.

25.8.6 USART Channel Status Register

Name: CSR

Access Type: Read-only

31	30	29	28	27	26	25	24
–	–	–	–	–	–	–	MANERR
23	22	21	20	19	18	17	16
CTS	–	–	–	CTSIC	–	–	–
15	14	13	12	11	10	9	8
–	–	NACK	RXBUFF	TXBUFE	ITERATION	TXEMPTY	TIMEOUT
7	6	5	4	3	2	1	0
PARE	FRAME	OVRE	ENDTX	ENDRX	RXBRK	TXRDY	RXRDY

- **RXRDY: Receiver Ready**

0: No complete character has been received since the last read of RHR or the receiver is disabled. If characters were being received when the receiver was disabled, RXRDY changes to 1 when the receiver is enabled.

1: At least one complete character has been received and RHR has not yet been read.

- **TXRDY: Transmitter Ready**

0: A character is in the THR waiting to be transferred to the Transmit Shift Register, or an STTBRK command has been requested, or the transmitter is disabled. As soon as the transmitter is enabled, TXRDY becomes 1.

1: There is no character in the THR.

- **RXBRK: Break Received/End of Break**

0: No Break received or End of Break detected since the last RSTSTA.

1: Break Received or End of Break detected since the last RSTSTA.

- **ENDRX: End of Receiver Transfer**

0: The End of Transfer signal from the Receive PDC channel is inactive.

1: The End of Transfer signal from the Receive PDC channel is active.

- **ENDTX: End of Transmitter Transfer**

0: The End of Transfer signal from the Transmit PDC channel is inactive.

1: The End of Transfer signal from the Transmit PDC channel is active.

- **OVRE: Overrun Error**

0: No overrun error has occurred since the last RSTSTA.

1: At least one overrun error has occurred since the last RSTSTA.

- **FRAME: Framing Error**

0: No stop bit has been detected low since the last RSTSTA.

1: At least one stop bit has been detected low since the last RSTSTA.

- **PARE: Parity Error**

0: No parity error has been detected since the last RSTSTA.

1: At least one parity error has been detected since the last RSTSTA.

- **TIMEOUT: Receiver Time-out**

0: There has not been a time-out since the last Start Time-out command or the Time-out Register is 0.

1: There has been a time-out since the last Start Time-out command.

- **TXEMPTY: Transmitter Empty**

0: There are characters in either THR or the Transmit Shift Register, or the transmitter is disabled.

1: There is at least one character in either THR or the Transmit Shift Register.

- **ITERATION: Max number of Repetitions Reached**

0: Maximum number of repetitions has not been reached since the last RSIT.

1: Maximum number of repetitions has been reached since the last RSIT.

- **TXBUFE: Transmission Buffer Empty**

0: The signal Buffer Empty from the Transmit PDC channel is inactive.

1: The signal Buffer Empty from the Transmit PDC channel is active.

- **RXBUFF: Reception Buffer Full**

0: The signal Buffer Full from the Receive PDC channel is inactive.

1: The signal Buffer Full from the Receive PDC channel is active.

- **NACK: Non Acknowledge**

0: No Non Acknowledge has not been detected since the last RSTNACK.

1: At least one Non Acknowledge has been detected since the last RSTNACK.

- **CTSIC: Clear to Send Input Change Flag**

0: No input change has been detected on the CTS pin since the last read of CSR.

1: At least one input change has been detected on the CTS pin since the last read of CSR.

- **CTS: Image of CTS Input**

0: CTS is at 0.

1: CTS is at 1.

- **MANERR: Manchester Error**

0: No Manchester error has been detected since the last RSTSTA.

1: At least one Manchester error has been detected since the last RSTSTA.

25.8.7 USART Receive Holding Register

Name: RHR

Access Type: Read-only

31	30	29	28	27	26	25	24
–	–	–	–	–	–	–	–
23	22	21	20	19	18	17	16
–	–	–	–	–	–	–	–
15	14	13	12	11	10	9	8
RXSYNH	–	–	–	–	–	–	RXCHR
7	6	5	4	3	2	1	0
RXCHR							

- **RXCHR: Received Character**

Last character received if RXRDY is set.

- **RXSYNH: Received Sync**

0: Last Character received is a Data.

1: Last Character received is a Command.

25.8.8 USART Transmit Holding Register

Name: THR

Access Type: Write-only

31	30	29	28	27	26	25	24
–	–	–	–	–	–	–	–
23	22	21	20	19	18	17	16
–	–	–	–	–	–	–	–
15	14	13	12	11	10	9	8
TXSYNH	–	–	–	–	–	–	TXCHR
7	6	5	4	3	2	1	0
TXCHR							

- **TXCHR: Character to be Transmitted**

Next character to be transmitted after the current character if TXRDY is not set.

- **TXSYNH: Sync Field to be transmitted**

0: The next character sent is encoded as a data. Start Frame Delimiter is DATA SYNC.

1: The next character sent is encoded as a command. Start Frame Delimiter is COMMAND SYNC.

25.8.9 USART Baud Rate Generator Register

Name: BRGR

Access Type: Read/Write

31	30	29	28	27	26	25	24
–	–	–	–	–	–	–	–
23	22	21	20	19	18	17	16
–	–	–	–	–	FP		
15	14	13	12	11	10	9	8
CD							
7	6	5	4	3	2	1	0
CD							

• **CD: Clock Divider**

CD	MODE ≠ ISO7816			MODE = ISO7816
	SYNC = 0		SYNC = 1	
	OVER = 0	OVER = 1		
0	Baud Rate Clock Disabled			
1 to 65535	Baud Rate = Selected Clock/16/CD	Baud Rate = Selected Clock/8/CD	Baud Rate = Selected Clock /CD	Baud Rate = Selected Clock/CD/FI_DI_RATIO

• **FP: Fractional Part**

0: Fractional divider is disabled.

1 - 7: Baudrate resolution, defined by $FP \times 1/8$.

25.8.10 USART Receiver Time-out Register

Name: RTOR

Access Type: Read/Write

31	30	29	28	27	26	25	24
-	-	-	-	-	-	-	-
23	22	21	20	19	18	17	16
-	-	-	-	-	-	-	-
15	14	13	12	11	10	9	8
TO							
7	6	5	4	3	2	1	0
TO							

• **TO: Time-out Value**

0: The Receiver Time-out is disabled.

1 - 65535: The Receiver Time-out is enabled and the Time-out delay is TO x Bit Period.

25.8.11 USART Transmitter Timeguard Register

Name: TTGR

Access Type: Read/Write

31	30	29	28	27	26	25	24
-	-	-	-	-	-	-	-
23	22	21	20	19	18	17	16
-	-	-	-	-	-	-	-
15	14	13	12	11	10	9	8
-	-	-	-	-	-	-	-
7	6	5	4	3	2	1	0
TG							

• **TG: Timeguard Value**

0: The Transmitter Timeguard is disabled.

1 - 255: The Transmitter timeguard is enabled and the timeguard delay is TG x Bit Period.

25.8.12 USART FI DI RATIO Register

Name: FIDI
Access Type: Read/Write
Reset Value : 0x174

31	30	29	28	27	26	25	24
-	-	-	-	-	-	-	-
23	22	21	20	19	18	17	16
-	-	-	-	-	-	-	-
15	14	13	12	11	10	9	8
-	-	-	-	-	FI_DI_RATIO		
7	6	5	4	3	2	1	0
FI_DI_RATIO							

- FI_DI_RATIO: FI Over DI Ratio Value**

0: If ISO7816 mode is selected, the Baud Rate Generator generates no signal.

1 - 2047: If ISO7816 mode is selected, the Baud Rate is the clock provided on SCK divided by FI_DI_RATIO.

25.8.13 USART Number of Errors Register

Name: NER

Access Type: Read-only

31	30	29	28	27	26	25	24
-	-	-	-	-	-	-	-
23	22	21	20	19	18	17	16
-	-	-	-	-	-	-	-
15	14	13	12	11	10	9	8
-	-	-	-	-	-	-	-
7	6	5	4	3	2	1	0
NB_ERRORS							

• **NB_ERRORS: Number of Errors**

Total number of errors that occurred during an ISO7816 transfer. This register automatically clears when read.

25.8.14 USART Manchester Configuration Register

Name: MAN

Access Type: Read/Write

31	30	29	28	27	26	25	24
–	DRIFT	–	RX_MPOL	–	–	RX_PP	
23	22	21	20	19	18	17	16
–	–	–	–	RX_PL			
15	14	13	12	11	10	9	8
–	–	–	TX_MPOL	–	–	TX_PP	
7	6	5	4	3	2	1	0
–	–	–	–	TX_PL			

- **TX_PL: Transmitter Preamble Length**

0: The Transmitter Preamble pattern generation is disabled

1 - 15: The Preamble Length is TX_PL x Bit Period

- **TX_PP: Transmitter Preamble Pattern**

TX_PP		Preamble Pattern default polarity assumed (TX_MPOL field not set)
0	0	ALL_ONE
0	1	ALL_ZERO
1	0	ZERO_ONE
1	1	ONE_ZERO

- **TX_MPOL: Transmitter Manchester Polarity**

0: Logic Zero is coded as a zero-to-one transition, Logic One is coded as a one-to-zero transition.

1: Logic Zero is coded as a one-to-zero transition, Logic One is coded as a zero-to-one transition.

- **RX_PL: Receiver Preamble Length**

0: The receiver preamble pattern detection is disabled

1 - 15: The detected preamble length is RX_PL x Bit Period

- **RX_PP: Receiver Preamble Pattern detected**

RX_PP		Preamble Pattern default polarity assumed (RX_MPOL field not set)
0	0	ALL_ONE
0	1	ALL_ZERO
1	0	ZERO_ONE
1	1	ONE_ZERO

- **RX_MPOL: Receiver Manchester Polarity**

0: Logic Zero is coded as a zero-to-one transition, Logic One is coded as a one-to-zero transition.

1: Logic Zero is coded as a one-to-zero transition, Logic One is coded as a zero-to-one transition.

- **DRIFT: Drift compensation**

0: The USART can not recover from an important clock drift

1: The USART can recover from clock drift. The 16X clock mode must be enabled.

25.8.15 USART IrDA FILTER Register

Name: IF

Access Type: Read/Write

31	30	29	28	27	26	25	24
-	-	-	-	-	-	-	-
23	22	21	20	19	18	17	16
-	-	-	-	-	-	-	-
15	14	13	12	11	10	9	8
-	-	-	-	-	-	-	-
7	6	5	4	3	2	1	0
IRDA_FILTER							

- **IRDA_FILTER: IrDA Filter**

Sets the filter of the IrDA demodulator.

26. AC97 Controller (AC97C)

Rev: 6144B

26.1 Features

- **Compliant with AC97 2.2 Component Specification**
- **2 independent communication channels**
 - **Codec Channel, dedicated to the AC97 Analog Front End Control and Status Monitoring**
 - **2 channels associated with DMA Controller interface for Isochronous Audio Streaming Transfer**
- **Variable Sampling Rate AC97 Codec Interface Support**
- **One Primary Codec Support**
- **Independent input and Output Slot to Channel Assignment, Several Slots Can Be Assigned to the Same Channel.**
- **Channels Support Mono/Stereo/Multichannel Samples of 10, 16, 18 and 20 Bits.**

26.2 Description

The AC97 Controller is the hardware implementation of the AC97 digital controller (DC'97) compliant with AC97 Component Specification 2.2. The AC97 Controller communicates with an audio codec (AC97) or a modem codec (MC'97) via the AC-link digital serial interface. All digital audio, modem and handset data streams, as well as control (command/status) informations are transferred in accordance to the AC-link protocol.

The AC97 Controller features a DMA Controller interface for audio streaming transfers. It also supports variable sampling rate and four Pulse Code Modulation (PCM) sample resolutions of 10, 16, 18 and 20 bits.

26.3 Block Diagram

Figure 26-1. Functional Block Diagram

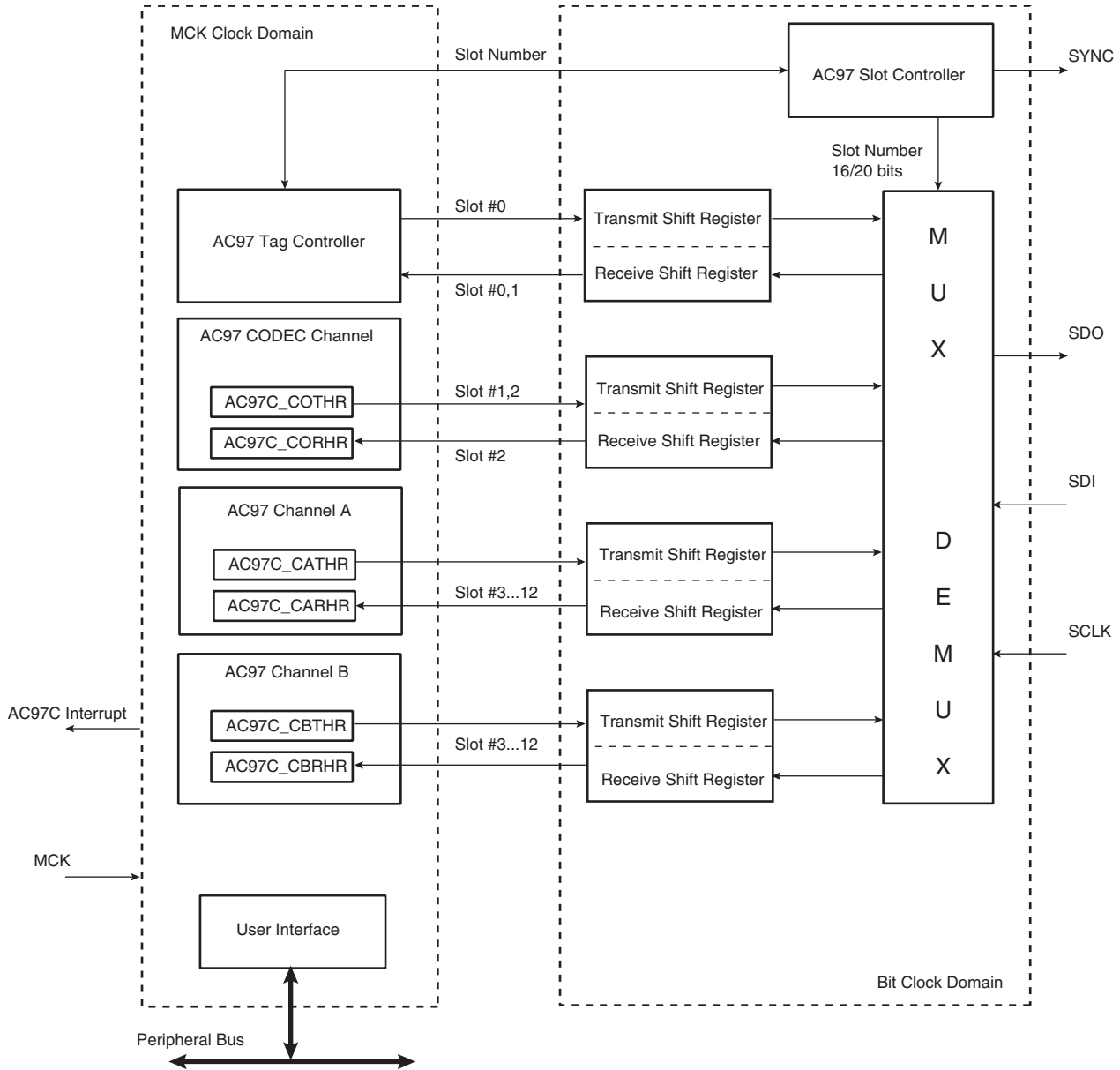

26.4 Pin Name List

Table 26-1. I/O Lines Description

Pin Name	Pin Description	Type
SCLK	12.288-MHz bit-rate clock (Referred as BITCLK in AC-link spec)	Input
SDI	Receiver Data (Referred as SDATA_IN in AC-link spec)	Input
SYNC	48-KHz frame indicator and synchronizer	Output
SDO	Transmitter Data (Referred as SDATA_OUT in AC-link spec)	Output

The AC97 reset signal provided to the primary codec can be generated by a PIO.

26.5 Application Block Diagram

Figure 26-2. Application Block diagram

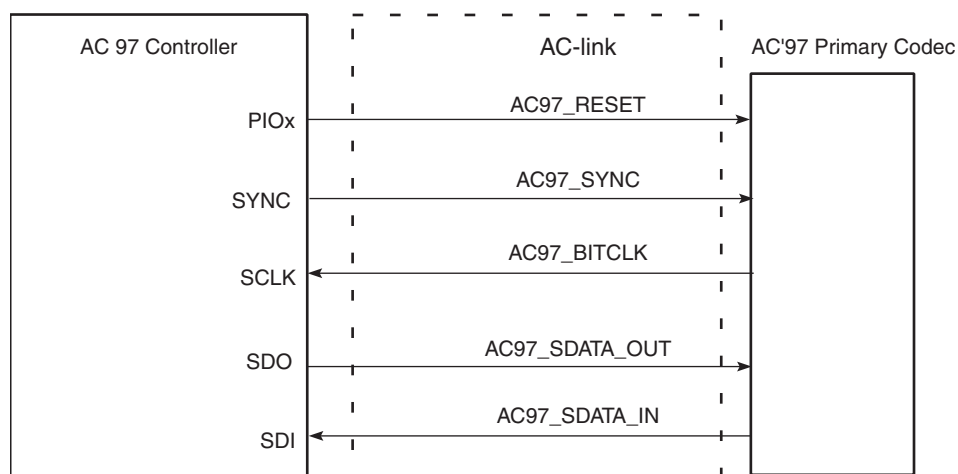

26.6 Product Dependencies

26.6.1 I/O Lines

The pins used for interfacing the compliant external devices may be multiplexed with PIO lines.

Before using the AC97 Controller receiver, the PIO controller must be configured in order for the AC97C receiver I/O lines to be in AC97 Controller peripheral mode.

Before using the AC97 Controller transmitter, the PIO controller must be configured in order for the AC97C transmitter I/O lines to be in AC97 Controller peripheral mode.

26.6.2 Power Management

The AC97 clock is generated by the power manager. Before using the AC97, the programmer must ensure that the AC'97 clock is enabled in the power manager.

In the AC97 description, Master Clock (MCK) is the clock of the peripheral bus to which the AC97 is connected. It is important that that the MCK clock frequency is higher than the SCLK (Bit Clock) clock frequency as signals that cross the two clock domains are re-synchronized.

26.6.3 Interrupt

The AC97 interface has an interrupt line connected to the interrupt controller. In order to handle interrupts, the interrupt controller must be programmed before configuring the AC97.

All AC97 Controller interrupts can be enabled/disabled by writing to the AC97 Controller Interrupt Enable/Disable Registers. Each pending and unmasked AC97 Controller interrupt will assert the interrupt line. The AC97 Controller interrupt service routine can get the interrupt source in two steps:

- Reading and ANDing AC97 Controller Interrupt Mask Register (IMR) and AC97 Controller Status Register (SR).
- Reading AC97 Controller Channel x Status Register (CxSR).

26.7 Functional Description

26.7.1 Protocol overview

AC-link protocol is a bidirectional, fixed clock rate, serial digital stream. AC-link handles multiple input and output Pulse Code Modulation PCM audio streams, as well as control register accesses employing a Time Division Multiplexed (TDM) scheme that divides each audio frame in 12 outgoing and 12 incoming 20-bit wide data slots.

Figure 26-3. Bidirectional AC-link Frame with Slot Assignment

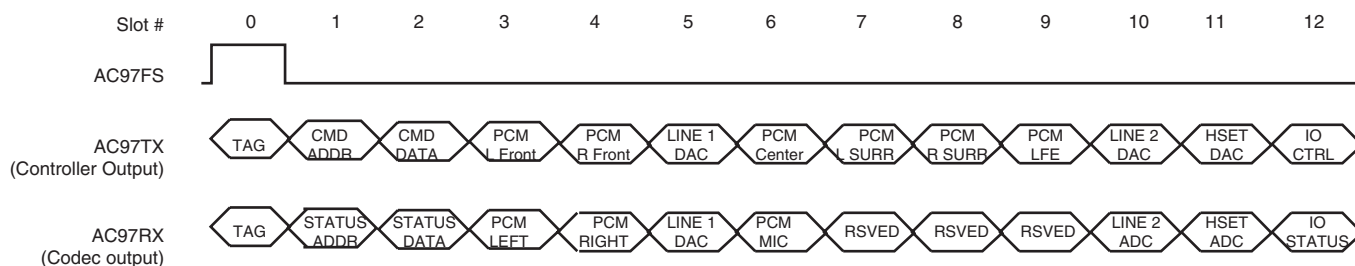

Table 26-2. AC-link Output Slots Transmitted from the AC97C Controller

Slot #	Pin Description
0	TAG
1	Command Address Port
2	Command Data Port
3,4	PCM playback Left/Right Channel
5	Modem Line 1 Output Channel
6, 7, 8	PCM Center/Left Surround/Right Surround
9	PCM LFE DAC
10	Modem Line 2 Output Channel
11	Modem Handset Output Channel
12	Modem GPIO Control Channel

Table 26-3. AC-link Input Slots Transmitted from the AC97C Controller

Slot #	Pin Description
0	TAG
1	Status Address Port
2	Status Data Port
3,4	PCM playback Left/Right Channel
5	Modem Line 1 ADC
6	Dedicated Microphone ADC
7, 8, 9	Vendor Reserved
10	Modem Line 2 ADC
11	Modem Handset Input ADC
12	Modem IO Status

26.7.2 Slot Description

26.7.2.1 Tag Slot

The tag slot, or slot 0, is a 16-bit wide slot that always goes at the beginning of an outgoing or incoming frame. Within tag slot, the first bit is a global bit that flags the entire frame validity. The next 12 bit positions sampled by the AC97 Controller indicate which of the corresponding 12 time slots contain valid data. The slot's last two bits (combined) called Codec ID, are used to distinguish primary and secondary codec.

The 16-bit wide tag slot of the output frame is automatically generated by the AC97 Controller according to the transmit request of each channel and to the SLOTRREQ from the previous input frame, sent by the AC97 Codec, in Variable Sample Rate mode.

26.7.2.2 Codec Slot 1

The command/status slot is a 20-bit wide slot used to control features, and monitors status for AC97 Codec functions.

The control interface architecture supports up to sixty-four 16-bit wide read/write registers. Only the even registers are currently defined and addressed.

Slot 1's bitmap is the following:

- Bit 19 is for read/write command, 1= read, 0 = write.
- Bits [18:12] are for control register index.
- Bits [11:0] are reserved.

26.7.2.3 Codec Slot 2

Slot 2 is a 20-bit wide slot used to carry 16-bit wide AC97 Codec control register data. If the current command port operation is a read, the entire slot time is stuffed with zeros. Its bitmap is the following:

- Bits [19:4] are the control register data
- Bits [3:0] are reserved and stuffed with zeros.

26.7.2.4 Data Slots [3:12]

Slots [3:12] are 20-bit wide data slots, they usually carry audio PCM or/and modem I/O data.

26.7.3 AC97 Controller Channel Organization

The AC97 Controller features a Codec channel and 2 logical channels; Channel A and Channel B.

The Codec channel controls AC97 Codec registers, it enables write and read configuration values in order to bring the AC97 Codec to an operating state. The Codec channel always runs slot 1 and slot 2 exclusively, in both input and output directions.

Channel A and Channel B transfer data to/from AC97 codec. All audio samples and modem data must transit by these two channels.

Each slot of the input or the output frame that belongs to this range [3 to 12] can be operated by either Channel A or Channel B. The slot to channel assignment is configured by two registers:

- AC97 Controller Input Channel Assignment Register (ICA)
- AC97 Controller Output Channel Assignment Register (OCA)

The AC97 Controller Input Channel Assignment Register (ICA) configures the input slot to channel assignment. The AC97 Controller Output Channel Assignment Register (OCA) configures the output slot to channel assignment.

A slot can be left unassigned to a channel by the AC97 Controller. Slots 0, 1, and 2 cannot be assigned to Channel A or to Channel B through the OCA and ICA Registers.

The width of sample data, that transit via Channel A and Channel B varies and can take one of these values; 10, 16, 18 or 20 bits.

Figure 26-4. Logical Channel Assignment

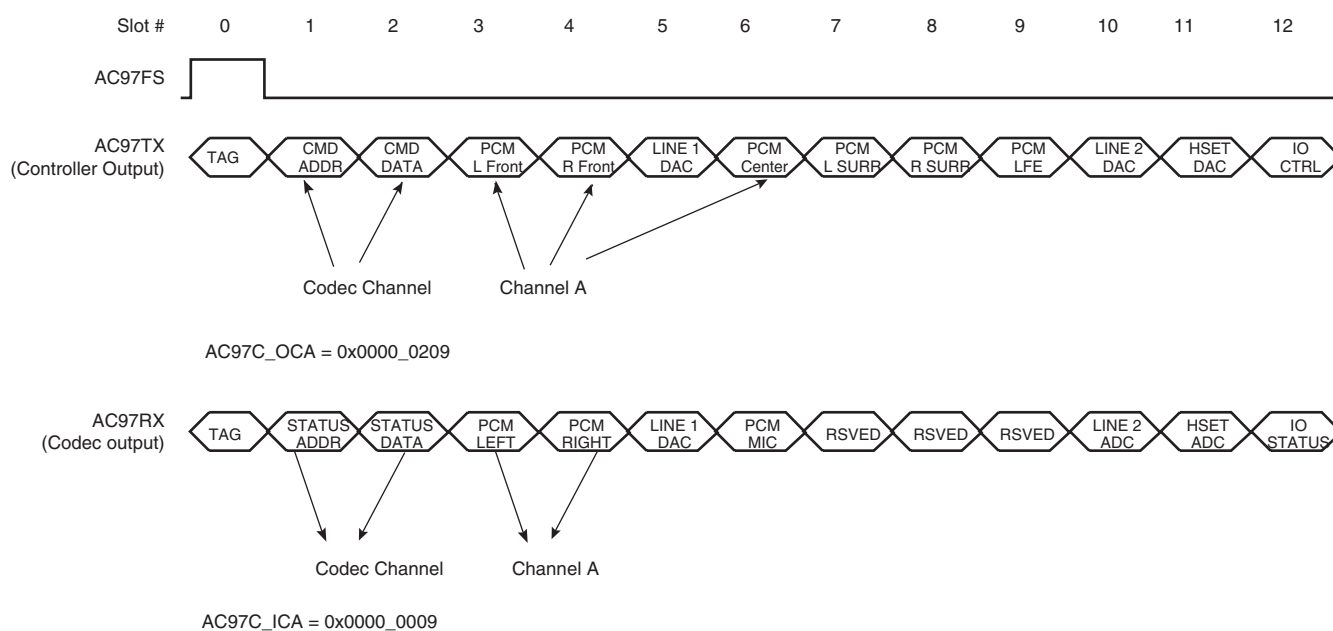

26.7.3.1 AC97 Controller Setup

The following operations must be performed in order to bring the AC97 Controller into an operating state:

1. Enable the AC97 Controller clock in the power manager.
2. Turn on AC97 function by enabling the ENA bit in AC97 Controller Mode Register (MR).
3. Configure the input channel assignment by controlling the AC97 Controller Input Assignment Register (ICA).
4. Configure the output channel assignment by controlling the AC97 Controller Input Assignment Register (OCA).
5. Configure sample width for Channel A and Channel B by writing the SIZE bit field in AC97C Channel A Mode Register (CAMR) and AC97C Channel B Mode Register (CBMR). The application can write 10, 16, 18, or 20-bit wide PCM samples through the AC97 interface and they will be transferred into 20-bit wide slots.
6. Configure data Endianness for Channel A and Channel B by writing CEM bit field in CAMR and CBMR registers. Data on the AC-link are shifted MSB first. The application can write little- or big-endian data to the AC97 Controller interface.
7. Configure the PIO controller to drive the RESET signal of the external Codec. The RESET signal must fulfill external AC97 Codec timing requirements.
8. Enable Channel A and/or Channel B by writing CEN bit field in CAMR and CBMR registers.

26.7.3.2 Transmit Operation

The application must perform the following steps in order to send data via a channel to the AC97 Codec:

- Check if previous data has been sent by polling TXRDY flag in the AC97C Channel x Status Register (CxSR). x being one of the 2 channels.
- Write data to the AC97 Controller Channel x Transmit Holding Register (CxTHR).

Once data has been transferred to the Channel x Shift Register, the TXRDY flag is automatically set by the AC97 Controller which allows the application to start a new write action. The application can also wait for an interrupt notice associated with TXRDY in order to send data. The interrupt remains active until TXRDY flag is cleared..

Figure 26-5. Audio Transfer (PCM L Front, PCM R Front) on Channel x

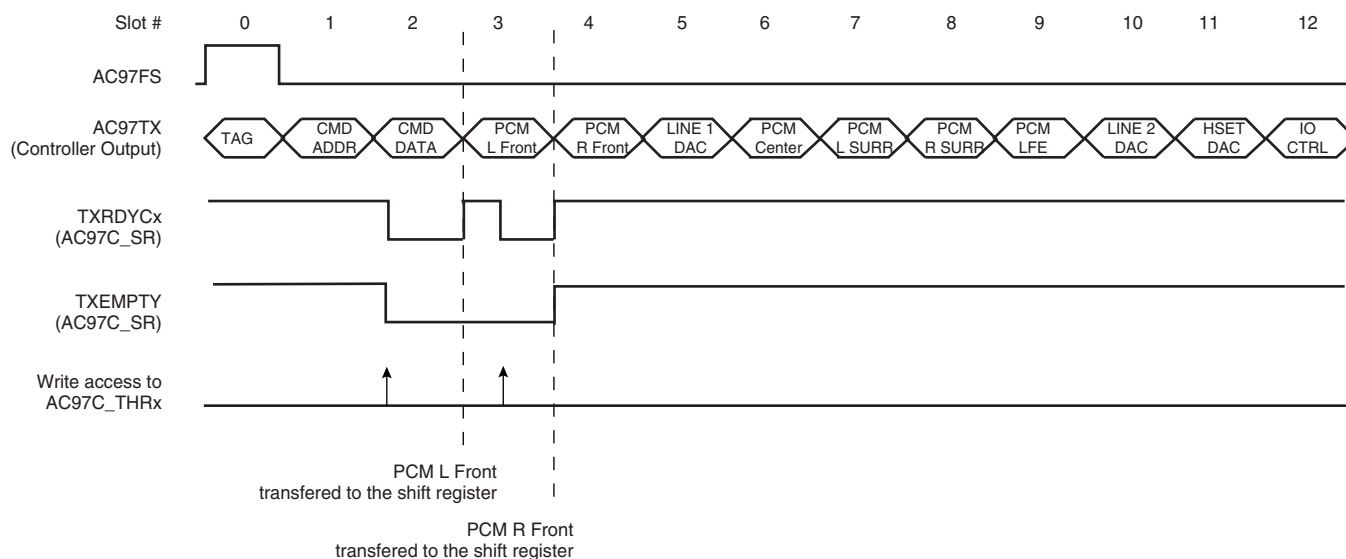

The TXEMPTY flag in the AC97 Controller Channel x Status Register (CxSR) is set when all requested transmissions for a channel have been shifted on the AC-link. The application can either poll TXEMPTY flag in CxSR or wait for an interrupt notice associated with the same flag.

In most cases, the AC97 Controller is embedded in chips that target audio player devices. In such cases, the AC97 Controller is exposed to heavy audio transfers. Using the polling technique increases processor overhead and may fail to keep the required pace under an operating system.

In order to avoid these polling drawbacks, the application can perform audio streams by using a DMA controller (DMAC) connected to both channels, which reduces processor overhead and increases performance especially under an operating system.

The DMAC transmit counter values must be equal to the number of PCM samples to be transmitted, each sample goes in one slot.

26.7.3.3 AC97 Output Frame

The AC97 Controller outputs a thirteen-slot frame on the AC-Link. The first slot (tag slot or slot 0) flags the validity of the entire frame and the validity of each slot; whether a slot carries valid data or not. Slots 1 and 2 are used if the application performs control and status monitoring actions on AC97 Codec control/status registers. Slots [3:12] are used according to the content of the AC97 Controller Output Channel Assignment Register (OCA). If the application performs many transmit requests on a channel, some of the slots associated to this channel or all of them will carry valid data.

26.7.3.4 Receive Operation

The AC97 Controller can also receive data from AC97 Codec. Data is received in the channel's shift register and then transferred to the AC97 Controller Channel x Read Holding Register. To read the newly received data, the application must perform the following steps:

- Poll RXRDY flag in AC97 Controller Channel x Status Register (CxSR). x being one of the 2 channels.
- Read data from AC97 Controller Channel x Read Holding Register.

The application can also wait for an interrupt notice in order to read data from CxRHR. The interrupt remains active until RXRDY is cleared by reading CxSR.

The RXRDY flag in CxSR is set automatically when data is received in the Channel x shift register. Data is then shifted to CxRHR.

Figure 26-6. Audio Transfer (PCM L Front, PCM R Front) on Channel x

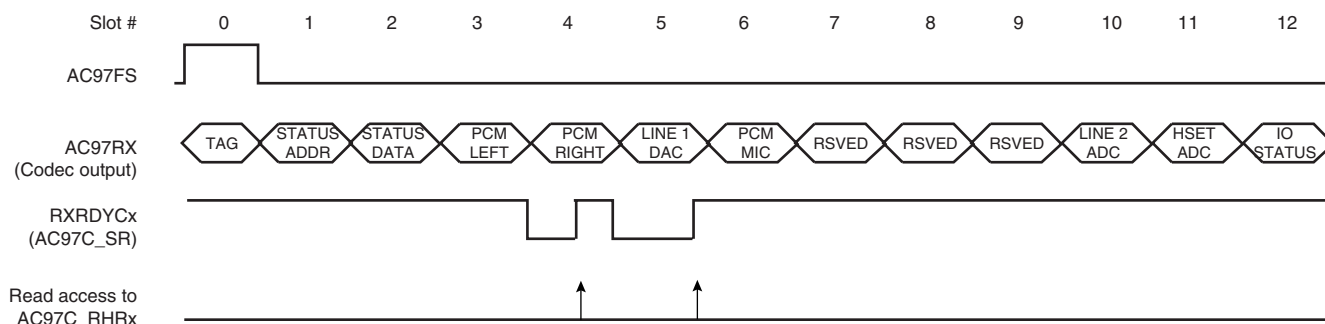

If the previously received data has not been read by the application, the new data overwrites the data already waiting in CxRHR, therefore the OVRUN flag in CxSR is raised. The application can either poll the OVRUN flag in CxSR or wait for an interrupt notice. The interrupt remains active until the OVRUN flag in CxSR is set.

The AC97 Controller can also be used in sound recording devices in association with an AC97 Codec. The AC97 Controller may also be exposed to heavy PCM transfers.

The application can use the DMAC connected to both channels in order to reduce processor overhead and increase performance especially under an operating system.

The DMAC receive counter values must be equal to the number of PCM samples to be received. When more than one timeslot is assigned to a channel using DMA, the different timeslot samples will be interleaved.

26.7.3.5 AC97 Input Frame

The AC97 Controller receives a thirteen slot frame on the AC-Link sent by the AC97 Codec. The first slot (tag slot or slot 0) flags the validity of the entire frame and the validity of each slot; whether a slot carries valid data or not. Slots 1 and 2 are used if the application requires status informations from AC97 Codec. Slots [3:12] are used according to AC97 Controller Output Channel Assignment Register (ICA) content. The AC97 Controller will not receive any data from any slot if ICA is not assigned to a channel in input.

26.7.3.6 Configuring and Using Interrupts

Instead of polling flags in AC97 Controller Global Status Register (SR) and in AC97 Controller Channel x Status Register (CxSR), the application can wait for an interrupt notice. The following steps show how to configure and use interrupts correctly:

- Set the interruptible flag in AC97 Controller Channel x Mode Register (CxMR).
- Set the interruptible event and channel event in AC97 Controller Interrupt Enable Register (IER).

The interrupt handler must read both AC97 Controller Global Status Register (SR) and AC97 Controller Interrupt Mask Register (IMR) and AND them to get the real interrupt source. Furthermore, to get which event was activated, the interrupt handler has to read AC97 Controller Channel x Status Register (CxSR), x being the channel whose event triggers the interrupt.

The application can disable event interrupts by writing in AC97 Controller Interrupt Disable Register (IDR). The AC97 Controller Interrupt Mask Register (IMR) shows which event can trigger an interrupt and which one cannot.

26.7.3.7 Endianness

Endianness can be managed automatically for each channel, except for the Codec channel, by writing to Channel Endianness Mode (CEM) in CxMR. This enables transferring data on AC-link in Little Endian format without any additional operation.

26.7.3.8 To Transmit a Word Stored in Little Endian Format on AC-link

Word to be written in AC97 Controller Channel x Transmit Holding Register (CxTHR) (as it is stored in memory or microprocessor register).

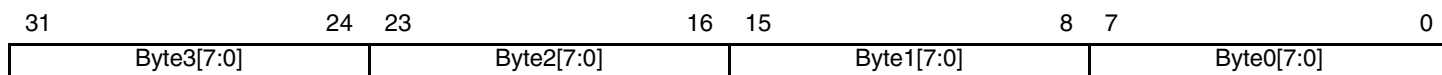

Word stored in Channel x Transmit Holding Register (AC97C_CxTHR) (data to transmit).

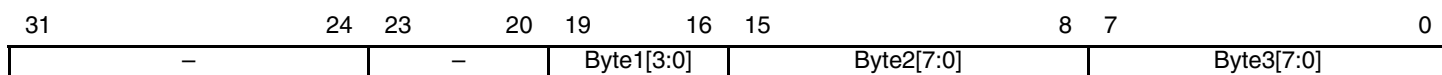

Data transmitted on appropriate slot: data[19:0] = {Byte1[3:0], Byte2[7:0], Byte3[7:0]}.

26.7.3.9 To Transmit A Halfword Stored in Little Endian Format on AC-link

Halfword to be written in AC97 Controller Channel x Transmit Holding Register (CxTHR).

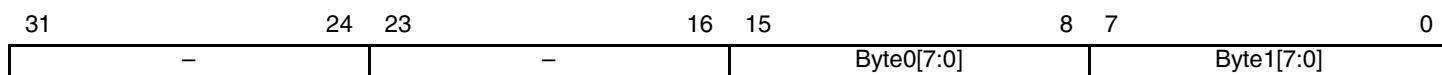

Halfword stored in AC97 Controller Channel x Transmit Holding Register (CxTHR) (data to transmit).

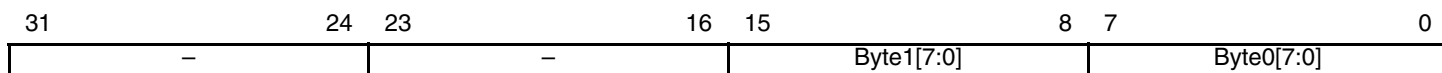

Data emitted on related slot: data[19:0] = {Byte1[7:0], Byte0[7:0], 0x0}.

26.7.3.10 To Transmit a 10-bit Sample Stored in Little Endian Format on AC-link

Halfword to be written in AC97 Controller Channel x Transmit Holding Register (CxTHR).

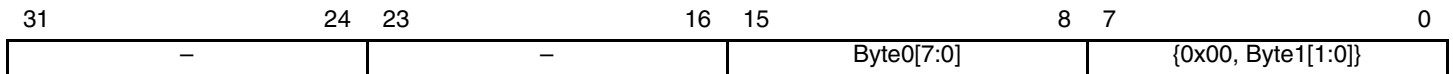

Halfword stored in AC97 Controller Channel x Transmit Holding Register (CxTHR) (data to transmit).

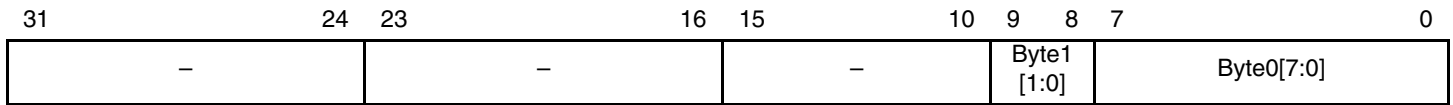

Data emitted on related slot: data[19:0] = {Byte1[1:0], Byte0[7:0], 0x000}.

26.7.3.11 To Receive Word transfers

Data received on appropriate slot: data[19:0] = {Byte2[3:0], Byte1[7:0], Byte0[7:0]}.

Word stored in AC97 Controller Channel x Receive Holding Register (CxRHR) (Received Data).



Data is read from AC97 Controller Channel x Receive Holding Register (CxRHR) when Channel x data size is greater than 16 bits and when little endian mode is enabled (data written to memory).

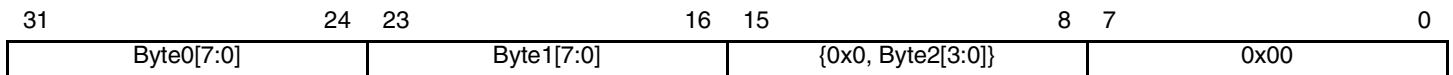

26.7.3.12 To Receive Halfword Transfers

Data received on appropriate slot: data[19:0] = {Byte1[7:0], Byte0[7:0], 0x0 }.

Halfword stored in AC97 Controller Channel x Receive Holding Register (CxRHR) (Received Data).

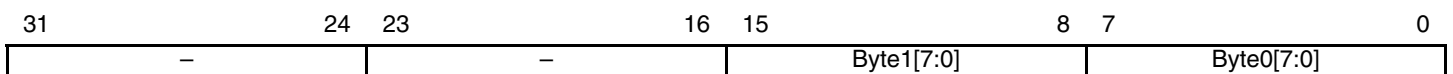

Data is read from AC97 Controller Channel x Receive Holding Register (CxRHR) when data size is equal to 16 bits and when little endian mode is enabled.

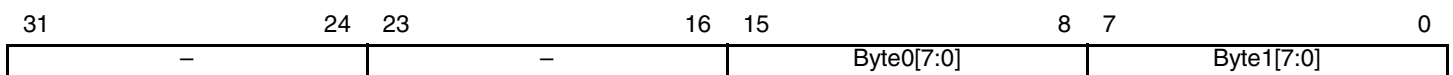

26.7.3.13 To Receive 10-bit Samples

Data received on appropriate slot: data[19:0] = {Byte1[1:0], Byte0[7:0], 0x000}. Halfword stored in AC97 Controller Channel x Receive Holding Register (CxRHR) (Received Data)

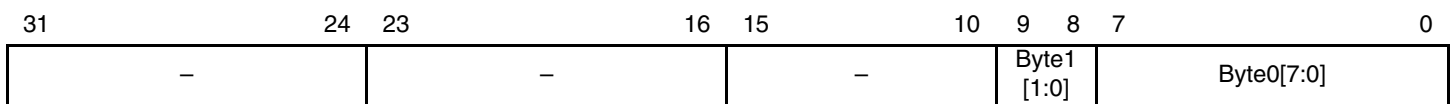

Data read from AC97 Controller Channel x Receive Holding Register (CxRHR) when data size is equal to 10 bits and when little endian mode is enabled.

31	24	23	16	15	8	7	3	1	0
-		-		Byte0[7:0]		0x00		Byte1 [1:0]	

26.7.4 Variable Sample Rate

The problem of variable sample rate can be summarized by a simple example. When passing a 44.1 kHz stream across the AC-link, for every 480 audio output frames that are sent across, 441 of them must contain valid sample data. The new AC97 standard approach calls for the addition of “on-demand” slot request flags. The AC97 Codec examines its sample rate control register, the state of its FIFOs, and the incoming SDATA_OUT tag bits (slot 0) of each output frame and then determines which SLOTREQ bits to set active (low). These bits are passed from the AC97 Codec to the AC97 Controller in slot 1/SLOTREQ in every audio input frame. Each time the AC97 controller sees one or more of the newly defined slot request flags set active (low) in a given audio input frame, it must pass along the next PCM sample for the corresponding slot(s) in the AC-link output frame that immediately follows.

The variable Sample Rate mode is enabled by performing the following steps:

- Setting the VRA bit in the AC97 Controller Mode Register (MR).
- Enable Variable Rate mode in the AC97 Codec by performing a transfer on the Codec channel.

Slot 1 of the input frame is automatically interpreted as SLOTREQ signaling bits. The AC97 Controller will automatically fill the active slots according to both SLOTREQ and OCA register in the next transmitted frame.

26.7.5 Power Management

26.7.5.1 Powering Down the AC-Link

The AC97 Codecs can be placed in low power mode. The application can bring AC97 Codec to a power down state by performing sequential writes to AC97 Codec powerdown register . Both the bit clock (clock delivered by AC97 Codec, SCLK) and the input line (SDI) are held at a logic low voltage level. This puts AC97 Codec in power down state while all its registers are still holding current values. Without the bit clock, the AC-link is completely in a power down state.

The AC97 Controller should not attempt to play or capture audio data until it has awakened AC97 Codec.

To set the AC97 Codec in low power mode, the PR4 bit in the AC97 Codec powerdown register (Codec address 0x26) must be set to 1. Then the primary Codec drives both BITCLK and SDI to a low logic voltage level.

The following operations must be done to put AC97 Codec in low power mode:

- Disable Channel A clearing CEN in the CAMR register.
- Disable Channel B clearing CEN field in the CBMR register.
- Write 0x2680 value in the COTHR register.
- Poll the TXEMPTY flag in CxSR registers for the 2 channels.

At this point AC97 Codec is in low power mode.

26.7.5.2 Waking up the AC-link

There are two methods to bring the AC-link out of low power mode. Regardless of the method, it is always the AC97 Controller that performs the wake-up.

26.7.5.3 Wake-up Triggered by the AC97 Controller

The AC97 Controller can wake up the AC97 Codec by issuing either a cold or a warm reset.

The AC97 Controller can also wake up the AC97 Codec by asserting SYNC signal, however this action should not be performed for a minimum period of four audio frames following the frame in which the powerdown was issued.

26.7.5.4 Wake-up Triggered by the AC97 Codec

This feature is implemented in AC97 modem codecs that need to report events such as Caller-ID and wake-up on ring.

The AC97 Codec can drive SDI signal from low to high level and holding it high until the controller issues either a cold or a warm reset. The SDI rising edge is asynchronously (regarding SYNC) detected by the AC97 Controller. If WKUP bit is enabled in IMR register, an interrupt is triggered that wakes up the AC97 Controller which should then immediately issue a cold or a warm reset.

If the processor needs to be awakened by an external event, the SDI signal must be externally connected to the WAKEUP entry of the system controller.

Figure 26-7. AC97 Power-Down/Up Sequence

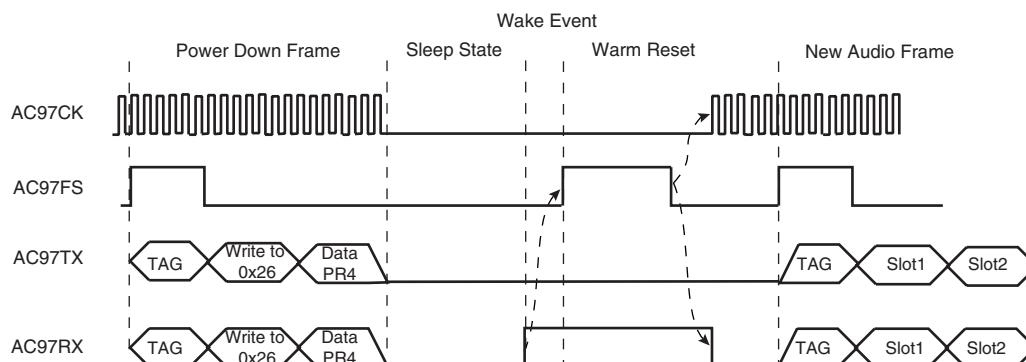

26.7.5.5 AC97 Codec Reset

There are three ways to reset an AC97 Codec.

26.7.5.6 Cold AC97 Reset

A cold reset is generated by asserting the RESET signal low for the minimum specified time (depending on the AC97 Codec) and then by de-asserting RESET high. BITCLK and SYNC is reactivated and all AC97 Codec registers are set to their default power-on values. Transfers on AC-link can resume.

The RESET signal will be controlled via a PIO line. This is how an application should perform a cold reset:

- Clear and set ENA flag in the MR register to reset the AC97 Controller
- Clear PIO line output controlling the AC97 RESET signal
- Wait for the minimum specified time
- Set PIO line output controlling the AC97 RESET signal

BITCLK, the clock provided by AC97 Codec, is detected by the controller.

26.7.5.7 Warm AC97 Reset

A warm reset reactivates the AC-link without altering AC97 Codec registers. A warm reset is signaled by driving AC97FX signal high for a minimum of 1us in the absence of BITCLK. In the absence of BITCLK, AC97FX is treated as an asynchronous (regarding AC97FX) input used to signal a warm reset to AC97 Codec.

This is the right way to perform a warm reset:

- Set WRST in the MR register.
- Wait for at least 1us
- Clear WRST in the MR register.

The application can check that operations have resumed by checking SOF flag in the SR register or wait for an interrupt notice if SOF is enabled in IMR.

26.8 AC97 Controller (AC97C) User Interface

Table 26-4. Register Mapping

Offset	Register	Register Name	Access	Reset
0x0-0x4	Reserved	–	–	–
0x8	Mode Register	MR	Read/Write	0x0
0xC	Reserved	–	–	–
0x10	Input Channel Assignment Register	ICA	Read/Write	0x0
0x14	Output Channel Assignment Register	OCA	Read/Write	0x0
0x18-0x1C	Reserved	–	–	–
0x20	Channel A Receive Holding Register	CARHR	Read	0x0
0x24	Channel A Transmit Holding Register	CATHR	Write	–
0x28	Channel A Status Register	CASR	Read	0x0
0x2C	Channel A Mode Register	CAMP	Read/Write	0x0
0x30	Channel B Receive Holding Register	CBRHR	Read	0x0
0x34	Channel B Transmit Holding Register	CBTHR	Write	–
0x38	Channel B Status Register	CBSR	Read	0x0
0x3C	Channel B Mode Register	CBMR	Read/Write	0x0
0x40	Codec Receive Holding Register	CORHR	Read	0x0
0x44	Codec Transmit Holding Register	COTHR	Write	–
0x48	Codec Status Register	COSR	Read	0x0
0x4C	Codec Mode Register	COMR	Read/Write	0x0
0x50	Status Register	SR	Read	0x0
0x54	Interrupt Enable Register	IER	Write	–
0x58	Interrupt Disable Register	IDR	Write	–
0x5C	Interrupt Mask Register	IMR	Read	0x0
0x60-0xFB	Reserved	–	–	–

26.8.1 AC97 Controller Mode Register

Name: MR
Access Type: Read-Write

31	30	29	28	27	26	25	24
–	–	–	–	–	–	–	–
23	22	21	20	19	18	17	16
–	–	–	–	–	–	–	–
15	14	13	12	11	10	9	8
–	–	–	–	–	–	–	–
7	6	5	4	3	2	1	0
–	–	–	–	–	VRA	WRST	ENA

- **VRA: Variable Rate (for Data Slots 3-12)**

0: Variable Rate is inactive. (48 KHz only)
 1: Variable Rate is active.

- **WRST: Warm Reset**

0: Warm Reset is inactive.
 1: Warm Reset is active.

- **ENA: AC97 Controller Global Enable**

0: No effect. AC97 function as well as access to other AC97 Controller registers are disabled.
 1: Activates the AC97 function.

26.8.2 AC97 Controller Input Channel Assignment Register

Register Name: ICA
Access Type: Read/Write

31	30	29	28	27	26	25	24
–	–	CHID12			CHID11		
23	22	21	20	19	18	17	16
CHID10			CHID9			CHID8	
15	14	13	12	11	10	9	8
CHID8	CHID7			CHID6			CHID5
7	6	5	4	3	2	1	0
CHID5		CHID4			CHID3		

- **CHIDx:** Channel ID for the input slot x

CHIDx	Selected Receive Channel
0x0	None. No data will be received during this Slot x
0x1	Channel A data will be received during this slot time.
0x2	Channel B data will be received during this slot time

26.8.3 AC97 Controller Output Channel Assignment Register

Register Name: OCA

Access Type: Read/Write

31	30	29	28	27	26	25	24
-		-		CHID12		CHID11	
23	22	21	20	19	18	17	16
CHID10			CHID9			CHID8	
15	14	13	12	11	10	9	8
CHID8		CHID7		CHID6		CHID5	
7	6	5	4	3	2	1	0
CHID5		CHID4			CHID3		

- **CHIDx:** Channel ID for the output slot x

CHIDx	Selected Transmit Channel
0x0	None. No data will be transmitted during this Slot x
0x1	Channel A data will be transferred during this slot time.
0x2	Channel B data will be transferred during this slot time

26.8.4 AC97 Controller Codec Channel Receive Holding Register

Register Name: CORHR

Access Type: Read-only

31	30	29	28	27	26	25	24
–	–	–	–	–	–	–	–
23	22	21	20	19	18	17	16
–	–	–	–	–	–	–	–
15	14	13	12	11	10	9	8
SDATA							
7	6	5	4	3	2	1	0
SDATA							

- **SDATA: Status Data**

Data sent by the CODEC in the third AC97 input frame slot (Slot 2).

26.8.5 AC97 Controller Codec Channel Transmit Holding Register

Register Name: COTHR

Access Type: Write-only

31	30	29	28	27	26	25	24
–	–	–	–	–	–	–	–
23	22	21	20	19	18	17	16
READ	CADDR						
15	14	13	12	11	10	9	8
CDATA							
7	6	5	4	3	2	1	0
CDATA							

- **READ: Read/Write command**

0: Write operation to the CODEC register indexed by the CADDR address.

1: Read operation to the CODEC register indexed by the CADDR address.

This flag is sent during the second AC97 frame slot

- **CADDR: CODEC control register index**

Data sent to the CODEC in the second AC97 frame slot.

- **CDATA: Command Data**

Data sent to the CODEC in the third AC97 frame slot (Slot 2).

26.8.6 AC97 Controller Channel A, Channel B Receive Holding Register

Register Name: CARHR, CBRHR

Access Type: Read-only

31	30	29	28	27	26	25	24
–	–	–	–	–	–	–	–
23	22	21	20	19	18	17	16
–	–	–	–	RDATA			
15	14	13	12	11	10	9	8
RDATA							
7	6	5	4	3	2	1	0
RDATA							

- **RDATA: Receive Data**

Received Data on channel x.

26.8.7 AC97 Controller Channel A, channel B Transmit Holding Register

Register Name: CATHR, CBTHR

Access Type: Write-only

31	30	29	28	27	26	25	24
–	–	–	–	–	–	–	–
23	22	21	20	19	18	17	16
–	–	–	–	TDATA			
15	14	13	12	11	10	9	8
TDATA							
7	6	5	4	3	2	1	0
TDATA							

- **TDATA: Transmit Data**

Data to be sent on channel x.

26.8.8 AC97 Controller Channel A Status Register

Register Name: CASR

Access Type: Read-only

31	30	29	28	27	26	25	24
–	–	–	–	–	–	–	–
23	22	21	20	19	18	17	16
–	–	–	–	–	–	–	–
15	14	13	12	11	10	9	8
–	–	–	–	–	–	–	–
7	6	5	4	3	2	1	0
–	–	OVRUN	RXRDY	–	UNRUN	TXEMPTY	TXRDY

26.8.9 AC97 Controller Channel B Status Register

Register Name: CBSR

Access Type: Read-only

31	30	29	28	27	26	25	24
–	–	–	–	–	–	–	–
23	22	21	20	19	18	17	16
–	–	–	–	–	–	–	–
15	14	13	12	11	10	9	8
–	–	–	–	–	–	–	–
7	6	5	4	3	2	1	0
–	–	OVRUN	RXRDY	–	UNRUN	TXEMPTY	TXRDY

26.8.10 AC97 Controller Codec Channel Status Register

Register Name: COSR

Access Type: Read-only

31	30	29	28	27	26	25	24
–	–	–	–	–	–	–	–
23	22	21	20	19	18	17	16
–	–	–	–	–	–	–	–
15	14	13	12	11	10	9	8
–	–	–	–	–	–	–	–
7	6	5	4	3	2	1	0
–	–	OVRUN	RXRDY	–	–	TXEMPTY	TXRDY

- **TXRDY: Channel Transmit Ready**

0: Data has been loaded in Channel Transmit Register and is waiting to be loaded in the Channel Transmit Shift Register.

1: Channel Transmit Register is empty.

- **TXEMPTY: Channel Transmit Empty**

0: Data remains in the Channel Transmit Register or is currently transmitted from the Channel Transmit Shift Register.

1: Data in the Channel Transmit Register have been loaded in the Channel Transmit Shift Register and sent to the codec.

- **RXRDY: Channel Receive Ready**

0: Channel Receive Holding Register is empty.

1: Data has been received and loaded in Channel Receive Holding Register.

- **OVRUN: Receive Overrun**

Automatically cleared by a processor read operation.

0: No data has been loaded in the Channel Receive Holding Register while previous data has not been read since the last read of the Status Register.

1: Data has been loaded in the Channel Receive Holding Register while previous data has not yet been read since the last read of the Status Register.

26.8.11 AC97 Controller Channel A Mode Register

Register Name: CAMR

Access Type: Read/Write

31	30	29	28	27	26	25	24
–	–	–	–	–	–	–	–
23	22	21	20	19	18	17	16
–	DMAEN	CEN	–	–	CEM	SIZE	
15	14	13	12	11	10	9	8
–	–	–	–	–	–	–	–
7	6	5	4	3	2	1	0
–	–	OVRUN	RXRDY	–	UNRUN	TXEMPTY	TXRDY

- **DMAEN: DMA Enable**

0: Disable DMA transfers for this channel.

1: Enable DMA transfers for this channel using DMAC.

- **CEM: Channel A Endian Mode**

0: Transferring Data through Channel A is straight forward (Big Endian).

1: Transferring Data through Channel A from/to a memory is performed with from/to Little Endian format translation.

- **SIZE: Channel A Data Size**

SIZE Encoding

SIZE	Selected Channel
0x0	20 bits
0x1	18bits
0x2	16 bits
0x3	10 bits

Note: Each time slot in the data phase is 20 bit long. For example, if a 16-bit sample stream is being played to an AC 97 DAC, the first 16 bit positions are presented to the DAC MSB-justified. They are followed by the next four bit positions that the AC97 Controller fills with zeroes. This process ensures that the least significant bits do not introduce any DC biasing, regardless of the implemented DAC's resolution (16-, 18-, or 20-bit).

- **CEN: Channel A Enable**

0: Data transfer is disabled on Channel A.

1: Data transfer is enabled on Channel A.

26.8.12 AC97 Controller Channel B Mode Register

Register Name: CBMR

Access Type: Read/Write

31	30	29	28	27	26	25	24
–	–	–	–	–	–	–	–
23	22	21	20	19	18	17	16
–	DMAEN	CEN	–	–	CEM	SIZE	
15	14	13	12	11	10	9	8
–	–	–	–	–	–	–	–
7	6	5	4	3	2	1	0
–	–	OVRUN	RXRDY	–	UNRUN	TXEMPTY	TXRDY

- **DMAEN: DMA Enable**

0: Disable DMA transfers for this channel.

1: Enable DMA transfers for this channel using DMAC.

- **CEM: Channel B Endian Mode**

0: Transferring Data through Channel B is straight forward (Big Endian).

1: Transferring Data through Channel B from/to a memory is performed with from/to Little Endian format translation.

- **SIZE: Channel B Data Size**

SIZE Encoding

SIZE	Selected Channel
0x0	20 bits
0x1	18bits
0x2	16 bits
0x3	10 bits

Note: Each time slot in the data phase is 20 bit long. For example, if a 16-bit sample stream is being played to an AC 97 DAC, the first 16 bit positions are presented to the DAC MSB-justified. They are followed by the next four bit positions that the AC97 Controller fills with zeroes. This process ensures that the least significant bits do not introduce any DC biasing, regardless of the implemented DAC's resolution (16-, 18-, or 20-bit).

- **CEN: Channel B Enable**

0: Data transfer is disabled on Channel B.

1: Data transfer is enabled on Channel B.

26.8.13 AC97 Controller Codec Channel Mode Register

Register Name: COMR

Access Type: Read/Write

31	30	29	28	27	26	25	24
–	–	–	–	–	–	–	–
23	22	21	20	19	18	17	16
–	–	–	–	–	–	–	–
15	14	13	12	11	10	9	8
–	–	–	–	–	–	–	–
7	6	5	4	3	2	1	0
–	–	OVRUN	RXRDY	–	–	TXEMPTY	TXRDY

- **TXRDY: Channel Transmit Ready Interrupt Enable**
- **TXEMPTY: Channel Transmit Empty Interrupt Enable**
- **RXRDY: Channel Receive Ready Interrupt Enable**
- **OVRUN: Receive Overrun Interrupt Enable**

0: Read: the corresponding interrupt is disabled. Write: disables the corresponding interrupt.

1: Read: the corresponding interrupt is enabled. Write: enables the corresponding interrupt.

26.8.14 AC97 Controller Status Register

Register Name: SR

Access Type: Read-only

31	30	29	28	27	26	25	24
–	–	–	–	–	–	–	–
23	22	21	20	19	18	17	16
–	–	–	–	–	–	–	–
15	14	13	12	11	10	9	8
–	–	–	–	–	–	–	–
7	6	5	4	3	2	1	0
–	–	–	CBEVT	CAEVT	COEVT	WKUP	SOF

WKUP and SOF flags in SR register are automatically cleared by a processor read operation.

- **SOF: Start Of Frame**

0: No Start of Frame has been detected since the last read of the Status Register.

1: At least one Start of frame has been detected since the last read of the Status Register.

- **WKUP: Wake Up detection**

0: No Wake-up has been detected.

1: At least one rising edge on SDATA_IN has been asynchronously detected. That means AC97 Codec has notified a wake-up.

- **COEVT: CODEC Channel Event**

A Codec channel event occurs when COSR AND COMR is not 0. COEVT flag is automatically cleared when the channel event condition is cleared.

0: No event on the CODEC channel has been detected since the last read of the Status Register.

1: At least one event on the CODEC channel is active.

- **CAEVT: Channel A Event**

A channel A event occurs when CASR AND CAMR is not 0. CAEVT flag is automatically cleared when the channel event condition is cleared.

0: No event on the channel A has been detected since the last read of the Status Register.

1: At least one event on the channel A is active.

- **CBEVT: Channel B Event**

A channel B event occurs when CBSR AND CBMR is not 0. CBEVT flag is automatically cleared when the channel event condition is cleared.

0: No event on the channel B has been detected since the last read of the Status Register.

1: At least one event on the channel B is active.

26.8.15 AC97 Controller Interrupt Enable Register

Register Name: IER

Access Type: Write-only

31	30	29	28	27	26	25	24
–	–	–	–	–	–	–	–
23	22	21	20	19	18	17	16
–	–	–	–	–	–	–	–
15	14	13	12	11	10	9	8
–	–	–	–	–	–	–	–
7	6	5	4	3	2	1	0
–	–	–	CBEVT	CAEVT	COEVT	WKUP	SOF

- **SOF: Start Of Frame**
- **WKUP: Wake Up**
- **COEVT: Codec Event**
- **CAEVT: Channel A Event**
- **CBEVT: Channel B Event**

0: No Effect.

1: Enables the corresponding interrupt.

26.8.16 AC97 Controller Interrupt Disable Register

Register Name: IDR

Access Type: Write-only

31	30	29	28	27	26	25	24
–	–	–	–	–	–	–	–
23	22	21	20	19	18	17	16
–	–	–	–	–	–	–	–
15	14	13	12	11	10	9	8
–	–	–	–	–	–	–	–
7	6	5	4	3	2	1	0
–	–	–	CBEVT	CAEVT	COEVT	WKUP	SOF

- **SOF: Start Of Frame**
- **WKUP: Wake Up**
- **COEVT: Codec Event**
- **CAEVT: Channel A Event**
- **CBEVT: Channel B Event**

0: No Effect.

1: Disables the corresponding interrupt.

26.8.17 AC97 Controller Interrupt Mask Register

Register Name: IMR

Access Type: Read-only

31	30	29	28	27	26	25	24
–	–	–	–	–	–	–	–
23	22	21	20	19	18	17	16
–	–	–	–	–	–	–	–
15	14	13	12	11	10	9	8
–	–	–	–	–	–	–	–
7	6	5	4	3	2	1	0
–	–	–	CBEVT	CAEVT	COEVT	WKUP	SOF

- **SOF: Start Of Frame**
- **WKUP: Wake Up**
- **COEVT: Codec Event**
- **CAEVT: Channel A Event**
- **CBEVT: Channel B Event**

0: The corresponding interrupt is disabled.

1: The corresponding interrupt is enabled.

27. Audio DAC - (DAC)

27.1 Features

- Digital Stereo DAC
- Oversampled D/A conversion architecture
 - Oversampling ratio fixed 128x
 - FIR equalization filter
 - Digital interpolation filter: Comb4
 - 3rd Order Sigma-Delta D/A converters
- Digital bitstream outputs
- Parallel interface
- Connected to DMA Controller for background transfer without CPU intervention

27.2 Description

The Audio DAC converts a 16-bit sample value to a digital bitstream with an average value proportional to the sample value. Two channels are supported, making the Audio DAC particularly suitable for stereo audio. Each channel has a pair of complementary digital outputs, DACn and DACn_N, which can be connected to an external high input impedance amplifier.

The Audio DAC is comprised of two 3rd order Sigma Delta D/A converter with an oversampling ratio of 128. The samples are upsampled with a 4th order Sinc interpolation filter (Comb4) before being input to the Sigma Delta Modulator. In order to compensate for the pass band frequency response of the interpolation filter and flatten the overall frequency response, the input to the interpolation filter is first filtered with a simple 3-tap FIR filter. The total frequency response of the Equalization FIR filter and the interpolation filter is given in [Figure 27-2 on page 479](#). The digital output bitstreams from the Sigma Delta Modulators should be low-pass filtered to remove high frequency noise inserted by the Modulation process.

The output DACn and DACn_N should be as ideal as possible before filtering, to achieve the best SNR quality. The output can be connected to a class D amplifier output stage, or it can be low pass filtered and connected to a high input impedance amplifier. A simple 1st order or higher low pass filter that filters all the frequencies above 50 kHz should be adequate.

27.3 Block Diagram

Figure 27-1. Functional Block Diagram

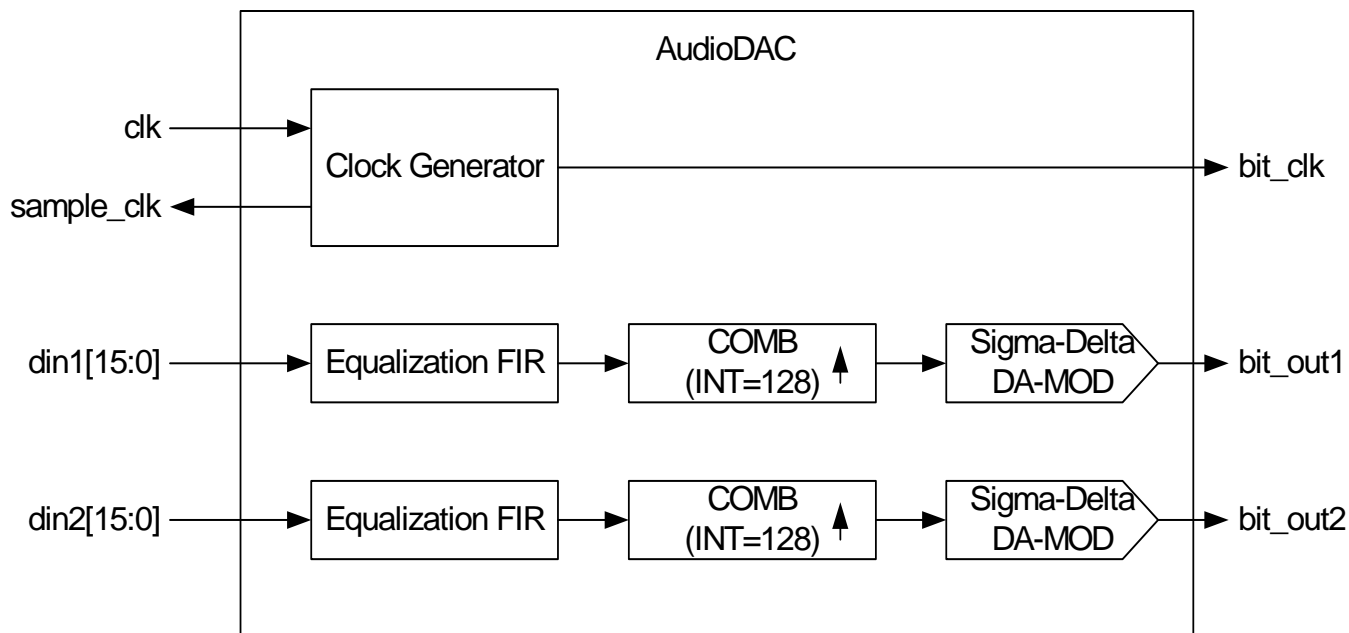

27.4 Pin Name List

Table 27-1. I/O Lines Description

Pin Name	Pin Description	Type
DATA0	Output from Audio DAC Channel 0	Output
DATA1	Output from Audio DAC Channel 1	Output
DATAN0	Inverted output from Audio DAC Channel 0	Output
DATAN1	Inverted output from Audio DAC Channel 1	Output

27.5 Product Dependencies

27.5.1 I/O Lines

The output pins used for the output bitstream from the Audio DAC may be multiplexed with PIO lines.

Before using the Audio DAC, the PIO controller must be configured in order for the Audio DAC I/O lines to be in Audio DAC peripheral mode.

27.5.2 Power Management

The PB-bus clock to the Audio DAC is generated by the power manager. Before using the Audio DAC, the programmer must ensure that the Audio DAC clock is enabled in the power manager.

27.5.3 Clock Management

The Audio DAC needs a separate clock for the D/A conversion operation. This clock should be set up in the generic clock register in the power manager. The frequency of this clock must be 256 times the frequency of the desired samplerate (f_s). For $f_s=48\text{kHz}$ this means that the clock must have a frequency of 12.288MHz.

27.5.4 Interrupts

The Audio DAC interface has an interrupt line connected to the interrupt controller. In order to handle interrupts, the interrupt controller must be programmed before configuring the Audio DAC.

All Audio DAC interrupts can be enabled/disabled by writing to the Audio DAC Interrupt Enable/Disable Registers. Each pending and unmasked Audio DAC interrupt will assert the interrupt line. The Audio DAC interrupt service routine can get the interrupt source by reading the Interrupt Status Register.

27.5.5 DMA

The Audio DAC is connected to the DMA controller. The DMA controller can be programmed to automatically transfer samples to the Audio DAC Sample Data Register (SDR) when the Audio DAC is ready for new samples. This enables the Audio DAC to operate without any CPU intervention such as polling the Interrupt Status Register (ISR) or using interrupts. See the DMA controller documentation for details on how to setup DMA transfers.

27.6 Functional Description

In order to use the Audio DAC the product dependencies given in [Section 27.5 on page 468](#) must be resolved. Particular attention should be given to the configuration of clocks and I/O lines in order to ensure correct operation of the Audio DAC.

The Audio DAC is enabled by writing the ENABLE bit in the Audio DAC Control Register (CR). The two 16-bit sample values for channel 0 and 1 can then be written to the least and most significant halfword of the Sample Data Register (SDR), respectively. The TX_READY bit in the Interrupt Status Register (ISR) will be set whenever the DAC is ready to receive a new sample. A new sample value should be written to SDR before 256 DAC clock cycles, or an underrun will occur, as indicated by the UNDERRUN status flags in ISR. ISR is cleared when read, or when writing one to the corresponding bits in the Interrupt Clear Register (ICR).

For interrupt-based operation, the relevant interrupts must be enabled by writing one to the corresponding bits in the Interrupt Enable Register (IER). Interrupts can be disabled by the Interrupt Disable Register (IDR), and active interrupts are indicated in the read-only Interrupt Mask Register (IMR).

The Audio DAC can also be configured for peripheral DMA access, in which case only the enable bit in the control register needs to be set in the Audio DAC module.

27.6.1 Equalization Filter

The equalization filter is a simple 3-tap FIR filter. The purpose of this filter is to compensate for the pass band frequency response of the sinc interpolation filter. The equalization filter makes the pass band response more flat and moves the -3dB corner a little higher.

27.6.2 Interpolation filter

The interpolation filter interpolates from f_s to $128f_s$. This filter is a 4th order Cascaded Integrator-Comb filter, and the basic building blocks of this filter is a comb part and an integrator part.

27.6.3 Sigma Delta Modulator

This part is a 3rd order Sigma Delta Modulator consisting of three differentiators (delta blocks), three integrators (sigma blocks) and a one bit quantizer. The purpose of the integrators is to shape the noise, so that the noise is reduced in the band of interest and increased at the higher frequencies, where it can be filtered.

27.6.4 Data Format

Input data is on two's complement format.

27.7 Audio DAC User Interface

Table 27-2. Register Mapping

Offset	Register	Register Name	Access	Reset
0x0	Sample Data Register	SDR	Read/Write	0x0
0x4	Reserved	-	-	-
0x8	Control Register	CR	Read/Write	0x0
0xc	Interrupt Mask Register	IMR	Read	0x0
0x10	Interrupt Enable Register	IER	Write	-
0x14	Interrupt Disable Register	IDR	Write	-
0x18	Interrupt Clear Register	ICR	Write	-
0x1C	Interrupt Status Register	ISR	Read	0x0

27.7.1 Audio DAC Sample Data Register

Name: SDR
Access Type: Read-Write

31	30	29	28	27	26	25	24
CHANNEL1							
23	22	21	20	19	18	17	16
CHANNEL1							
15	14	13	12	11	10	9	8
CHANNEL0							
7	6	5	4	3	2	1	0
CHANNEL0							

- **CHANNEL0: Sample Data for Channel 0**

Signed 16-bit Sample Data for channel 0. When the SWAP bit in the DAC Control Register (CR) is set writing to the Sample Data Register (SDR) will cause the values written to CHANNEL0 and CHANNEL1 to be swapped.

- **CHANNEL1: Sample Data for Channel 1**

Signed 16-bit Sample Data for channel 1. When the SWAP bit in the DAC Control Register (CR) is set writing to the Sample Data Register (SDR) will cause the values written to CHANNEL0 and CHANNEL1 to be swapped.

27.7.2 Audio DAC Control Register

Name: CR

Access Type: Read-Write

31	30	29	28	27	26	25	24
EN	SWAP	-	-	-	-	-	-
23	22	21	20	19	18	17	16
-	-	-	-	-	-	-	-
15	14	13	12	11	10	9	8
-	-	-	-	-	-	-	-
7	6	5	4	3	2	1	0
-	-	-	-	-	-	-	-

- **SWAP: Swap Channels**

0: The CHANNEL0 and CHANNEL1 samples will not be swapped when writing the Audio DAC Sample Data Register (SDR).

1: The CHANNEL0 and CHANNEL1 samples will be swapped when writing the Audio DAC Sample Data Register (SDR).

- **EN: Enable Audio DAC**

0: Audio DAC is disabled.

1: Audio DAC is enabled.

27.7.3 Audio DAC Interrupt Mask Register

Name: IMR

Access Type: Read-only

31	30	29	28	27	26	25	24
-	-	TX_READY	UNDERRUN	-	-	-	-
23	22	21	20	19	18	17	16
-	-	-	-	-	-	-	-
15	14	13	12	11	10	9	8
-	-	-	-	-	-	-	-
7	6	5	4	3	2	1	0
-	-	-	-	-	-	-	-

- **UNDERRUN: Underrun Interrupt Mask**

0: The Audio DAC Underrun interrupt is disabled.

1: The Audio DAC Underrun interrupt is enabled.

- **TX_READY: TX Ready Interrupt Mask**

0: The Audio DAC TX Ready interrupt is disabled.

1: The Audio DAC TX Ready interrupt is enabled.

27.7.4 Audio DAC Interrupt Enable Register

Name: IER

Access Type: Write-only

31	30	29	28	27	26	25	24
-	-	TX_READY	UNDERRUN	-	-	-	-
23	22	21	20	19	18	17	16
-	-	-	-	-	-	-	-
15	14	13	12	11	10	9	8
-	-	-	-	-	-	-	-
7	6	5	4	3	2	1	0
-	-	-	-	-	-	-	-

- **UNDERRUN: Underrun Interrupt Enable**

0: No effect.

1: Enables the Audio DAC Underrun interrupt.

- **TX_READY: TX Ready Interrupt Enable**

0: No effect.

1: Enables the Audio DAC TX Ready interrupt.

27.7.5 Audio DAC Interrupt Disable Register

Name: IDR

Access Type: Write-only

31	30	29	28	27	26	25	24
-	-	TX_READY	UNDERRUN	-	-	-	-
23	22	21	20	19	18	17	16
-	-	-	-	-	-	-	-
15	14	13	12	11	10	9	8
-	-	-	-	-	-	-	-
7	6	5	4	3	2	1	0
-	-	-	-	-	-	-	-

- **UNDERRUN: Underrun Interrupt Disable**

0: No effect.

1: Disable the Audio DAC Underrun interrupt.

- **TX_READY: TX Ready Interrupt Disable**

0: No effect.

1: Disable the Audio DAC TX Ready interrupt.

27.7.6 Audio DAC Interrupt Clear Register

Name: ICR

Access Type: Write-only

31	30	29	28	27	26	25	24
-	-	TX_READY	UNDERRUN	-	-	-	-
23	22	21	20	19	18	17	16
-	-	-	-	-	-	-	-
15	14	13	12	11	10	9	8
-	-	-	-	-	-	-	-
7	6	5	4	3	2	1	0
-	-	-	-	-	-	-	-

- **UNDERRUN: Underrun Interrupt Clear**

0: No effect.

1: Clear the Audio DAC Underrun interrupt.

- **TX_READY: TX Ready Interrupt Clear**

0: No effect.

1: Clear the Audio DAC TX Ready interrupt.

27.7.7 Audio DAC Interrupt Status Register

Name: ISR
Access Type: Read-only

31	30	29	28	27	26	25	24
-	-	TX_READY	UNDERRUN	-	-	-	-
23	22	21	20	19	18	17	16
-	-	-	-	-	-	-	-
15	14	13	12	11	10	9	8
-	-	-	-	-	-	-	-
7	6	5	4	3	2	1	0
-	-	-	-	-	-	-	-

• **UNDERRUN: Underrun Interrupt Status**

- 0: No Audio DAC Underrun has occurred since the last time ISR was read or since reset.
- 1: At least one Audio DAC Underrun has occurred since the last time ISR was read or since reset.

• **TX_READY: TX Ready Interrupt Status**

- 0: No Audio DAC TX Ready has occurred since the last time ISR was read.
- 1: At least one Audio DAC TX Ready has occurred since the last time ISR was read.

27.8 Frequency Response

Figure 27-2. Frequency response, EQ-FIR+COMB⁴

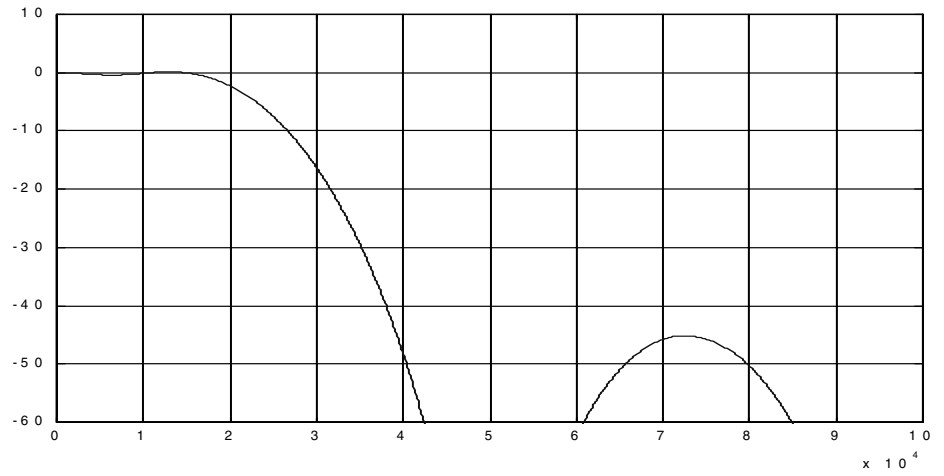

28. Static Memory Controller (SMC)

Rev: 1.0.4.0

28.1 Features

- **6 Chip Selects Available**
- **64-Mbyte Address Space per Chip Select**
- **8-, 16- or 32-bit Data Bus**
- **Word, Halfword, Byte Transfers**
- **Byte Write or Byte Select Lines**
- **Programmable Setup, Pulse And Hold Time for Read Signals per Chip Select**
- **Programmable Setup, Pulse And Hold Time for Write Signals per Chip Select**
- **Programmable Data Float Time per Chip Select**
- **Compliant with LCD Module**
- **External Wait Request**
- **Automatic Switch to Slow Clock Mode**
- **Asynchronous Read in Page Mode Supported: Page Size Ranges from 4 to 32 Bytes**

28.2 Description

The Static Memory Controller (SMC) generates the signals that control the access to the external memory devices or peripheral devices. It has 6 Chip Selects and a 26-bit address bus. The 32-bit data bus can be configured to interface with 8-, 16-, or 32-bit external devices. Separate read and write control signals allow for direct memory and peripheral interfacing. Read and write signal waveforms are fully parametrizable.

The SMC can manage wait requests from external devices to extend the current access. The SMC is provided with an automatic slow clock mode. In slow clock mode, it switches from user-programmed waveforms to slow-rate specific waveforms on read and write signals. The SMC supports asynchronous burst read in page mode access for page size up to 32 bytes.

28.3 Block Diagram

Figure 28-1. SMC Block Diagram

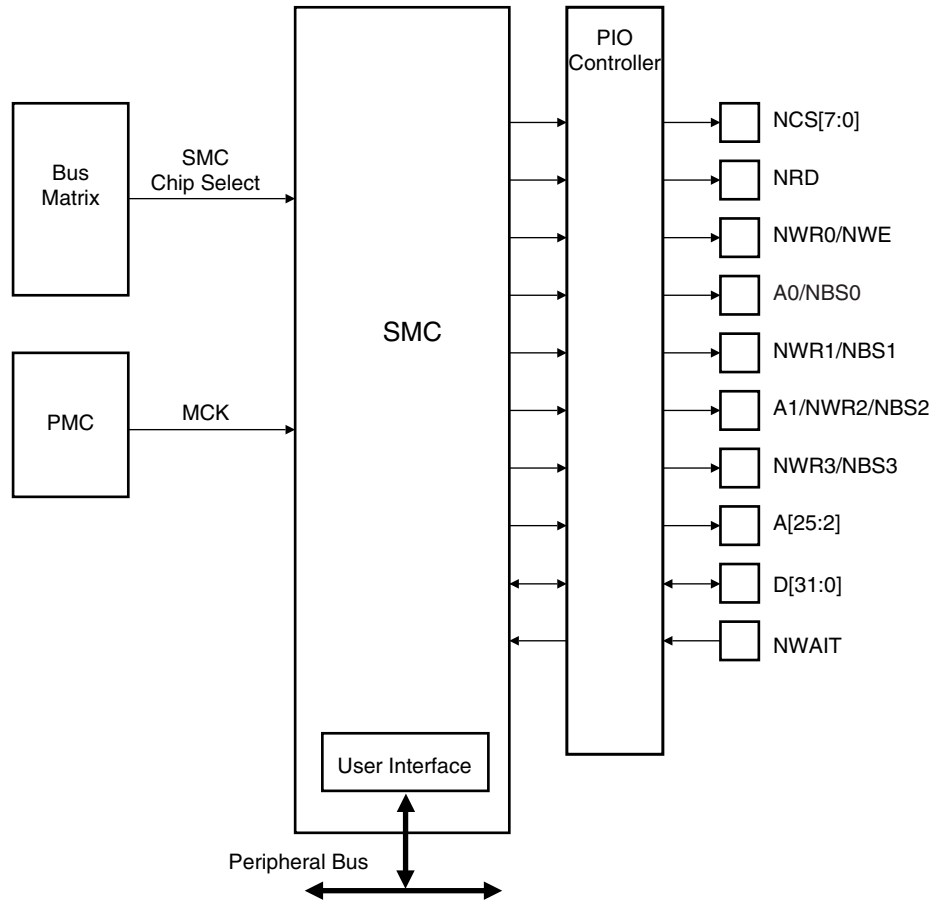

28.4 I/O Lines Description

Table 28-1. I/O Line Description

Name	Description	Type	Active Level
NCS[7:0]	Static Memory Controller Chip Select Lines	Output	Low
NRD	Read Signal	Output	Low
NWR0/NWE	Write 0/Write Enable Signal	Output	Low
A0/NBS0	Address Bit 0/Byte 0 Select Signal	Output	Low
NWR1/NBS1	Write 1/Byte 1 Select Signal	Output	Low
A1/NWR2/NBS2	Address Bit 1/Write 2/Byte 2 Select Signal	Output	Low
NWR3/NBS3	Write 3/Byte 3 Select Signal	Output	Low
A[25:2]	Address Bus	Output	
D[31:0]	Data Bus	I/O	
NWAIT	External Wait Signal	Input	Low

28.5 Multiplexed Signals

Table 28-2. Static Memory Controller (SMC) Multiplexed Signals

Multiplexed Signals			Related Function
NWR0	NWE		Byte-write or byte-select access, see "BAT - Byte Write or Byte Select Access" on page 484
A0	NBS0		8-bit or 16-/32-bit data bus, see "Data Bus Width" on page 484
NWR1	NBS1		Byte-write or byte-select access see "BAT - Byte Write or Byte Select Access" on page 484
A1	NWR2	NBS2	8-/16-bit or 32-bit data bus, see "Data Bus Width" on page 484. Byte-write or byte-select access, see "BAT - Byte Write or Byte Select Access" on page 484
NWR3	NBS3		Byte-write or byte-select access see "BAT - Byte Write or Byte Select Access" on page 484

28.6 Application Example

28.6.1 Hardware Interface

Figure 28-2. SMC Connections to Static Memory Devices

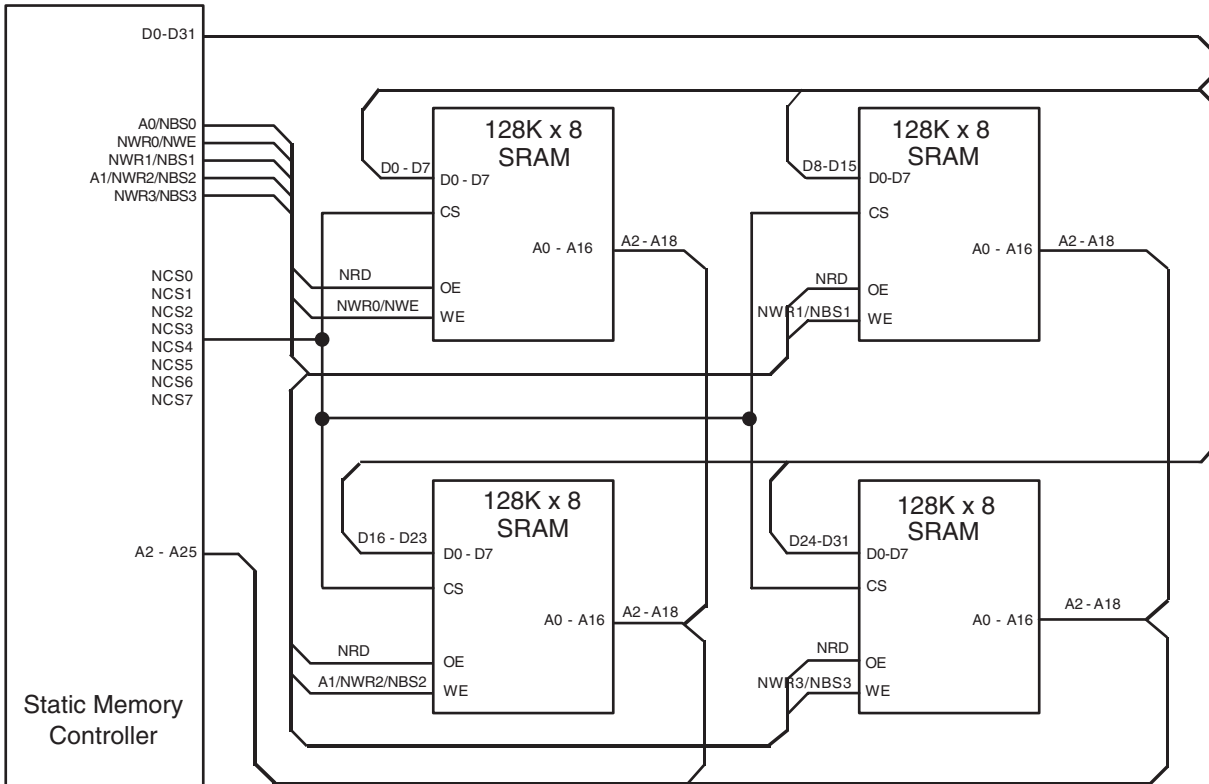

28.7 Product Dependencies

28.7.1 I/O Lines

The pins used for interfacing the Static Memory Controller may be multiplexed with the PIO lines. The programmer must first program the PIO controller to assign the Static Memory Controller pins to their peripheral function. If I/O Lines of the SMC are not used by the application, they can be used for other purposes by the PIO Controller.

28.8 External Memory Mapping

The SMC provides up to 26 address lines, A[25:0]. This allows each chip select line to address up to 64 Mbytes of memory.

If the physical memory device connected on one chip select is smaller than 64 Mbytes, it wraps around and appears to be repeated within this space. The SMC correctly handles any valid access to the memory device within the page (see [Figure 28-1](#)).

A[25:0] is only significant for 8-bit memory, A[25:1] is used for 16-bit memory, A[25:2] is used for 32-bit memory.

Figure 28-3. Memory Connections for Eight External Devices

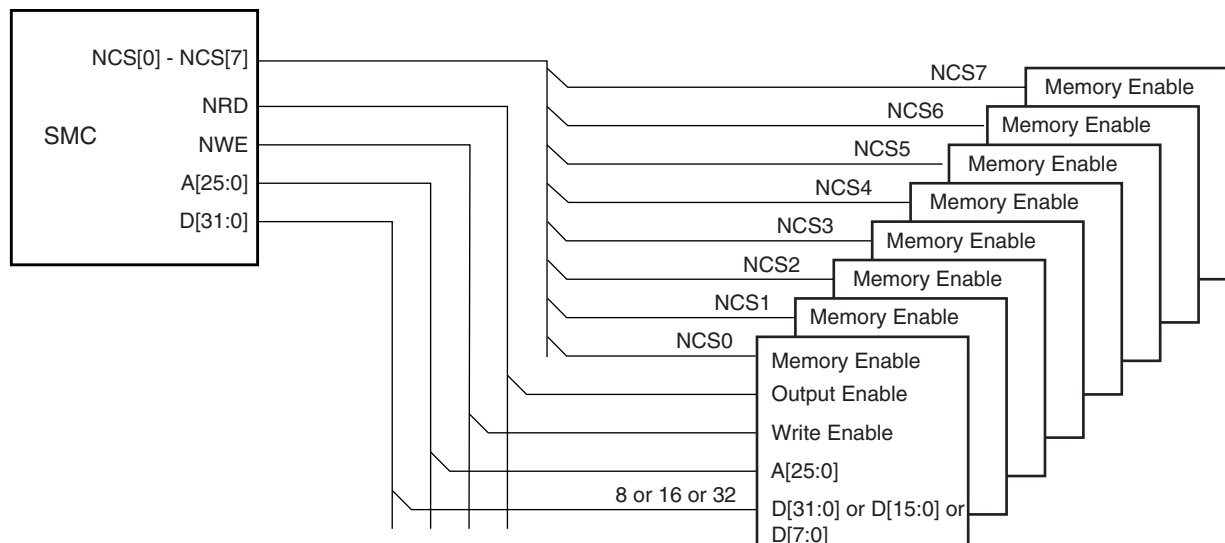

28.9 Connection to External Devices

28.9.1 Data Bus Width

A data bus width of 8, 16, or 32 bits can be selected for each chip select. This option is controlled by the field DBW in MODE (Mode Register) for the corresponding chip select.

[Figure 28-4](#) shows how to connect a 512K x 8-bit memory on NCS2. [Figure 28-5](#) shows how to connect a 512K x 16-bit memory on NCS2. [Figure 28-6](#) shows two 16-bit memories connected as a single 32-bit memory

28.9.2 BAT - Byte Write or Byte Select Access

Each chip select with a 16-bit or 32-bit data bus can operate with one of two different types of write access: byte write or byte select access. This is controlled by the BAT (BAT = Byte Select Access) field of the MODE register for the corresponding chip select.

Figure 28-4. Memory Connection for an 8-bit Data Bus

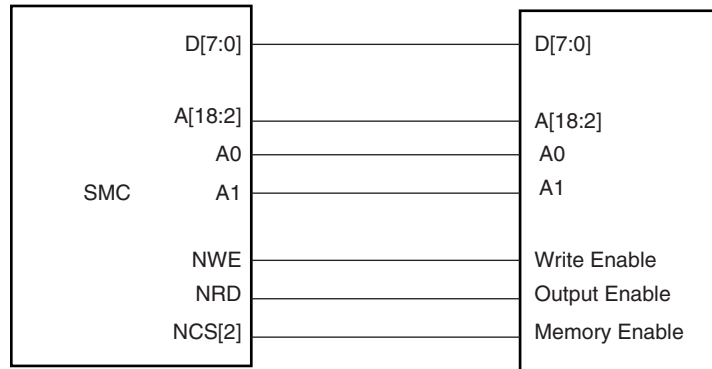

Figure 28-5. Memory Connection for a 16-bit Data Bus

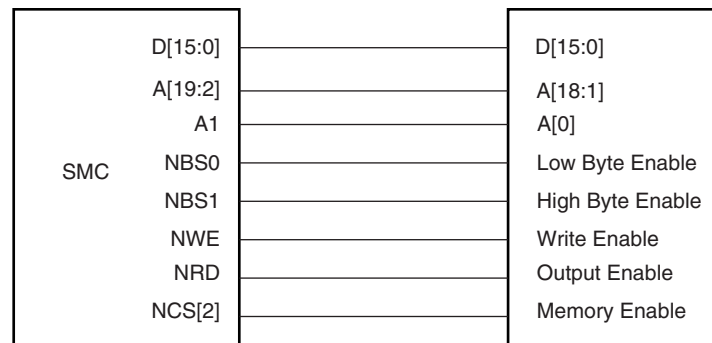
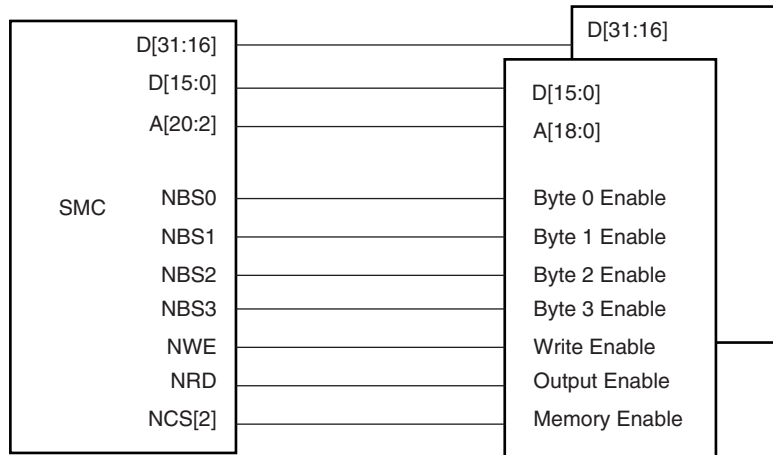

Figure 28-6. Memory Connection for a 32-bit Data Bus



28.9.2.1 Byte Write Access

Byte write access supports one byte write signal per byte of the data bus and a single read signal.

- For 16-bit devices: the SMC provides NWR0 and NWR1 write signals for respectively byte0 (lower byte) and byte1 (upper byte) of a 16-bit bus. One single read signal (NRD) is provided. Byte Write Access is used to connect 2 x 8-bit devices as a 16-bit memory.
- For 32-bit devices: NWR0, NWR1, NWR2 and NWR3, are the write signals of byte0 (lower byte), byte1, byte2 and byte 3 (upper byte) respectively. One single read signal (NRD) is provided. Byte Write Access is used to connect 4 x 8-bit devices as a 32-bit memory.

Byte Write option is illustrated on [Figure 28-7 on page 486](#).

28.9.2.2 Byte Select Access

In this mode, read/write operations can be enabled/disabled at a byte level. One byte-select line per byte of the data bus is provided. One NRD and one NWE signal control read and write.

- For 16-bit devices: the SMC provides NBS0 and NBS1 selection signals for respectively byte0 (lower byte) and byte1 (upper byte) of a 16-bit bus. Byte Select Access is used to connect one 16-bit device.
- For 32-bit devices: NBS0, NBS1, NBS2 and NBS3, are the selection signals of byte0 (lower byte), byte1, byte2 and byte 3 (upper byte) respectively. Byte Select Access is used to connect two 16-bit devices.

[Figure 28-8 on page 487](#) shows how to connect two 16-bit devices on a 32-bit data bus in Byte Select Access mode, on NCS3.

Figure 28-7. Connection of 2 x 8-bit Devices on a 16-bit Bus: Byte Write Option

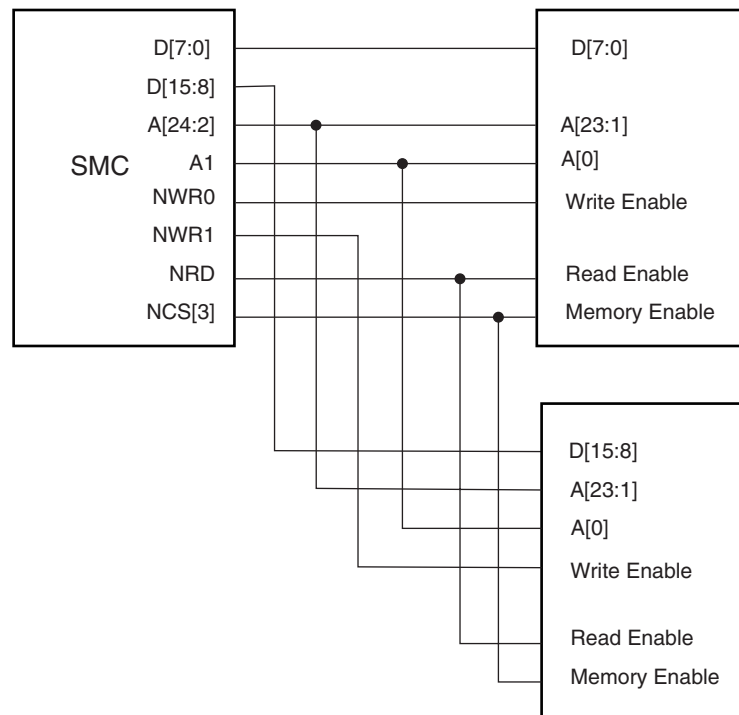

28.9.2.3 Signal Multiplexing

Depending on the BAT, only the write signals or the byte select signals are used. To save IOs at the external bus interface, control signals at the SMC interface are multiplexed. [Table 28-3 on page 487](#) shows signal multiplexing depending on the data bus width and the byte access type.

For 32-bit devices, bits A0 and A1 are unused. For 16-bit devices, bit A0 of address is unused. When Byte Select Option is selected, NWR1 to NWR3 are unused. When Byte Write option is selected, NBS0 to NBS3 are unused.

Figure 28-8. Connection of 2x16-bit Data Bus on a 32-bit Data Bus (Byte Select Option)

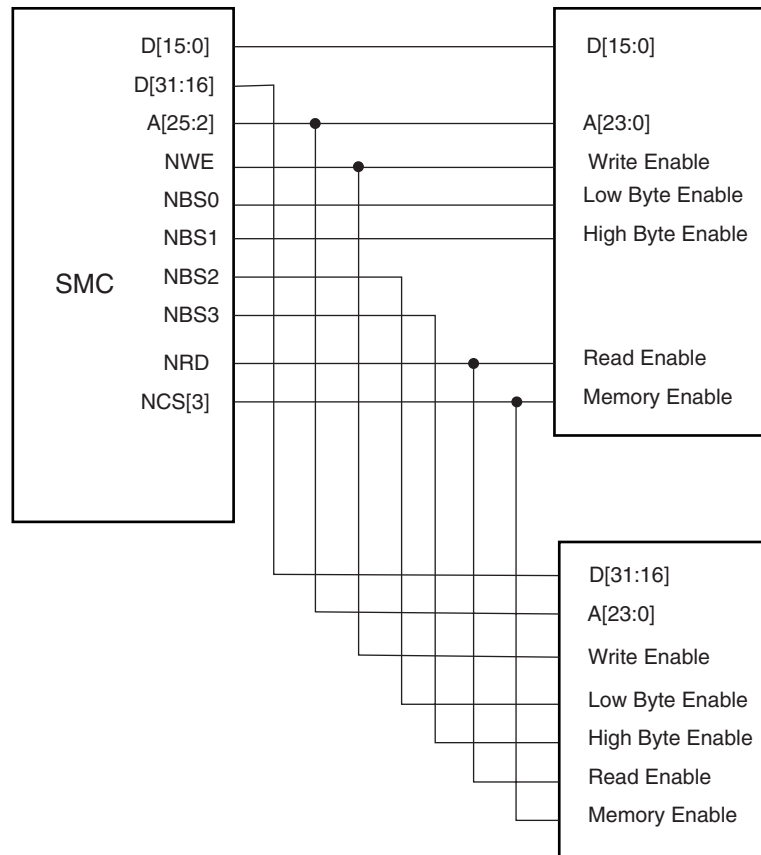

Table 28-3. SMC Multiplexed Signal Translation

Signal Name	32-bit Bus			16-bit Bus		8-bit Bus
	1x32-bit	2x16-bit	4 x 8-bit	1x16-bit	2 x 8-bit	1 x 8-bit
Device Type	1x32-bit	2x16-bit	4 x 8-bit	1x16-bit	2 x 8-bit	1 x 8-bit
Byte Access Type (BAT)	Byte Select	Byte Select	Byte Write	Byte Select	Byte Write	
NBS0_A0	NBS0	NBS0		NBS0		A0
NWE_NWR0	NWE	NWE	NWR0	NWE	NWR0	NWE
NBS1_NWR1	NBS1	NBS1	NWR1	NBS1	NWR1	
NBS2_NWR2_A1	NBS2	NBS2	NWR2	A1	A1	A1
NBS3_NWR3	NBS3	NBS3	NWR3			

28.10 Standard Read and Write Protocols

In the following sections, the byte access type is not considered. Byte select lines (NBS0 to NBS3) always have the same timing as the A address bus. NWE represents either the NWE signal in byte select access type or one of the byte write lines (NWR0 to NWR3) in byte write access type. NWR0 to NWR3 have the same timings and protocol as NWE. In the same way, NCS represents one of the NCS[0..NB_CS-1] chip select lines.

28.10.1 Read Waveforms

The read cycle is shown on [Figure 28-9 on page 488](#).

The read cycle starts with the address setting on the memory address bus, i.e.:

{A[25:2], A1, A0} for 8-bit devices

{A[25:2], A1} for 16-bit devices

A[25:2] for 32-bit devices.

Figure 28-9. Standard Read Cycle

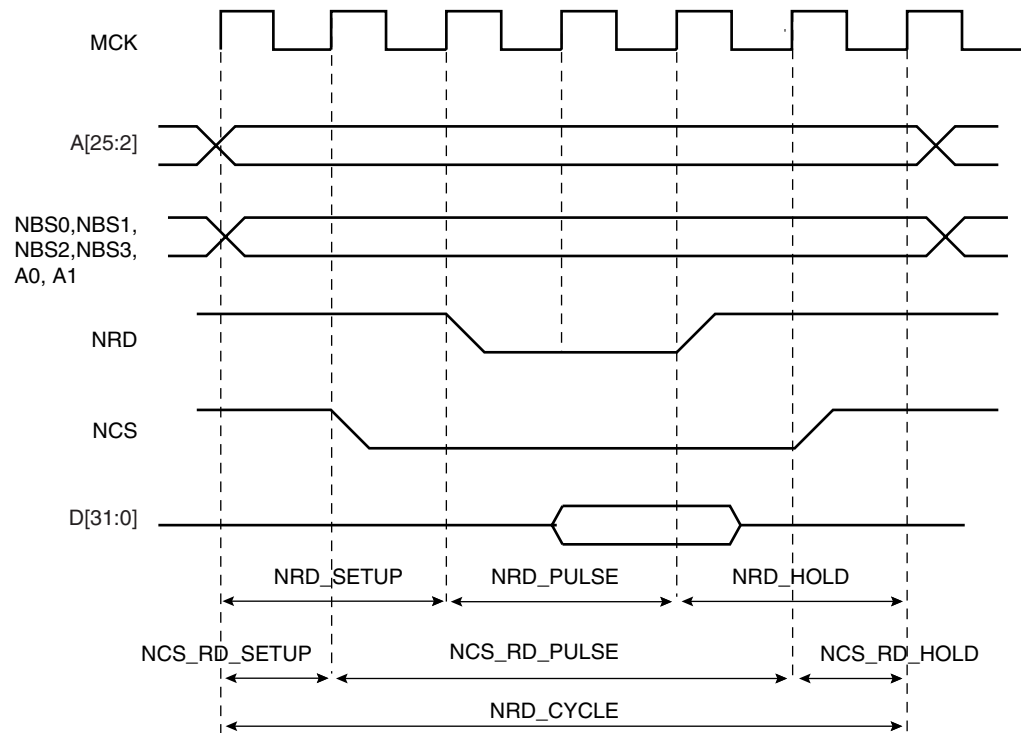

28.10.1.1 NRD Waveform

The NRD signal is characterized by a setup timing, a pulse width and a hold timing.

1. **NRD_SETUP:** the NRD setup time is defined as the setup of address before the NRD falling edge;
2. **NRD_PULSE:** the NRD pulse length is the time between NRD falling edge and NRD rising edge;
3. **NRD_HOLD:** the NRD hold time is defined as the hold time of address after the NRD rising edge.

28.10.1.2 NCS Waveform

Similarly, the NCS signal can be divided into a setup time, pulse length and hold time:

1. NCS_RD_SETUP: the NCS setup time is defined as the setup time of address before the NCS falling edge.
2. NCS_RD_PULSE: the NCS pulse length is the time between NCS falling edge and NCS rising edge;
3. NCS_RD_HOLD: the NCS hold time is defined as the hold time of address after the NCS rising edge.

28.10.1.3 Read Cycle

The NRD_CYCLE time is defined as the total duration of the read cycle, i.e., from the time where address is set on the address bus to the point where address may change. The total read cycle time is equal to:

$$\begin{aligned} \text{NRD_CYCLE} &= \text{NRD_SETUP} + \text{NRD_PULSE} + \text{NRD_HOLD} \\ &= \text{NCS_RD_SETUP} + \text{NCS_RD_PULSE} + \text{NCS_RD_HOLD} \end{aligned}$$

All NRD and NCS timings are defined separately for each chip select as an integer number of Master Clock cycles. To ensure that the NRD and NCS timings are coherent, user must define the total read cycle instead of the hold timing. NRD_CYCLE implicitly defines the NRD hold time and NCS hold time as:

$$\begin{aligned} \text{NRD_HOLD} &= \text{NRD_CYCLE} - \text{NRD_SETUP} - \text{NRD_PULSE} \\ \text{NCS_RD_HOLD} &= \text{NRD_CYCLE} - \text{NCS_RD_SETUP} - \text{NCS_RD_PULSE} \end{aligned}$$

28.10.1.4 Null Delay Setup and Hold

If null setup and hold parameters are programmed for NRD and/or NCS, NRD and NCS remain active continuously in case of consecutive read cycles in the same memory (see [Figure 28-10](#)).

Figure 28-10. No Setup, No Hold On NRD and NCS Read Signals

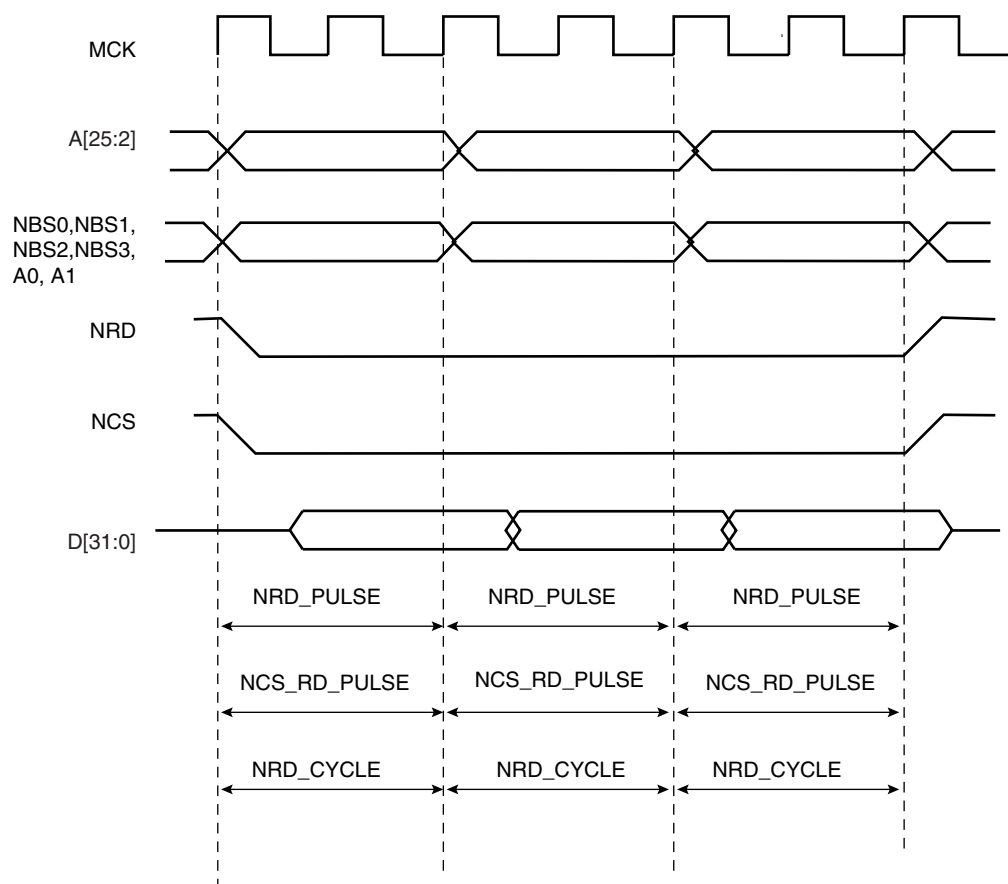

28.10.1.5 Null Pulse

Programming null pulse is not permitted. Pulse must be at least set to 1. A null value leads to unpredictable behavior.

28.10.2 Read Mode

As NCS and NRD waveforms are defined independently of one other, the SMC needs to know when the read data is available on the data bus. The SMC does not compare NCS and NRD timings to know which signal rises first. The `READ_MODE` parameter indicates which signal (NCS or NRD) controls the read operation. This parameter resides in the `MODE` register of the corresponding chip select.

28.10.2.1 Read is Controlled by NRD (`READ_MODE = 1`):

[Figure 28-11 on page 491](#) shows the waveforms of a read operation of a typical asynchronous RAM. The read data is available t_{PACC} after the falling edge of NRD, and turns to 'Z' after the rising edge of NRD. In this case, the `READ_MODE` must be set to 1 (read is controlled by NRD), to indicate that data is available with the rising edge of NRD. The SMC samples the read data internally on the rising edge of Master Clock that generates the rising edge of NRD, whatever the programmed waveform of NCS may be.

Figure 28-11. READ_MODE = 1: Data is sampled by SMC before the rising edge of NRD

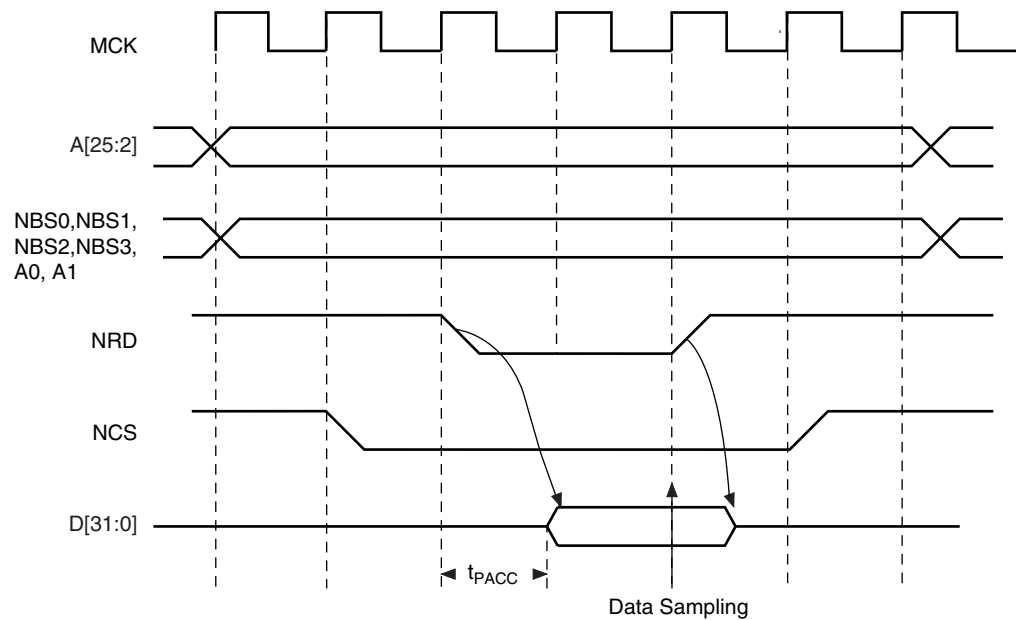

28.10.2.2 Read is Controlled by NCS (READ_MODE = 0)

Figure 28-12 on page 491 shows the typical read cycle of an LCD module. The read data is valid t_{PACC} after the falling edge of the NCS signal and remains valid until the rising edge of NCS. Data must be sampled when NCS is raised. In that case, the READ_MODE must be set to 0 (read is controlled by NCS): the SMC internally samples the data on the rising edge of Master Clock that generates the rising edge of NCS, whatever the programmed waveform of NRD may be.

Figure 28-12. READ_MODE = 0: Data is sampled by SMC before the rising edge of NCS

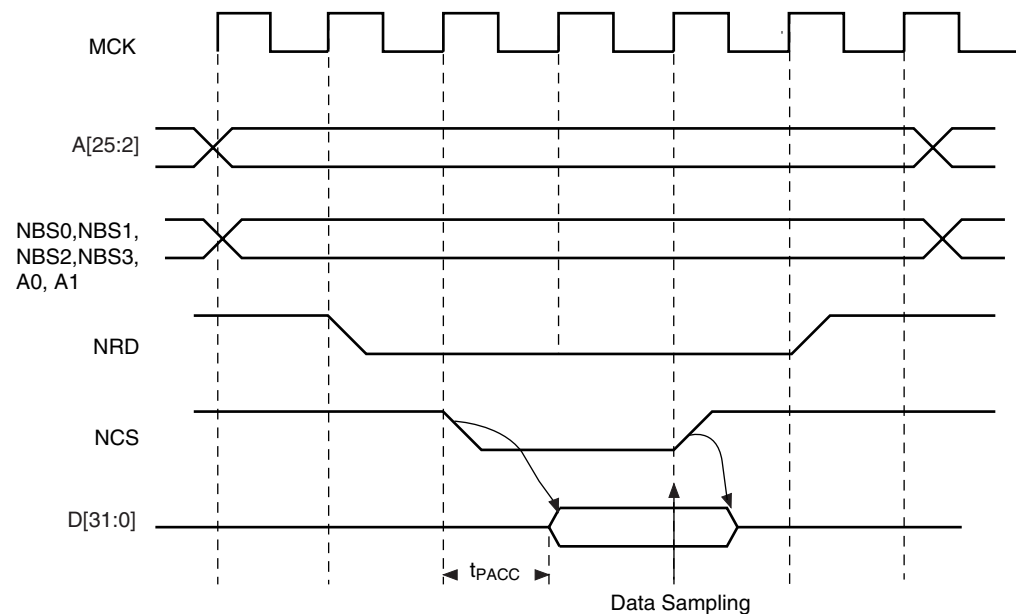

28.10.3 Write Waveforms

The write protocol is similar to the read protocol. It is depicted in [Figure 28-13 on page 492](#). The write cycle starts with the address setting on the memory address bus.

28.10.3.1 NWE Waveforms

The NWE signal is characterized by a setup timing, a pulse width and a hold timing.

1. NWE_SETUP: the NWE setup time is defined as the setup of address and data before the NWE falling edge;
2. NWE_PULSE: The NWE pulse length is the time between NWE falling edge and NWE rising edge;
3. NWE_HOLD: The NWE hold time is defined as the hold time of address and data after the NWE rising edge.

The NWE waveforms apply to all byte-write lines in Byte Write access mode: NWR0 to NWR3.

28.10.3.2 NCS Waveforms

The NCS signal waveforms in write operation are not the same that those applied in read operations, but are separately defined:

1. NCS_WR_SETUP: the NCS setup time is defined as the setup time of address before the NCS falling edge.
2. NCS_WR_PULSE: the NCS pulse length is the time between NCS falling edge and NCS rising edge;
3. NCS_WR_HOLD: the NCS hold time is defined as the hold time of address after the NCS rising edge.

Figure 28-13. Write Cycle

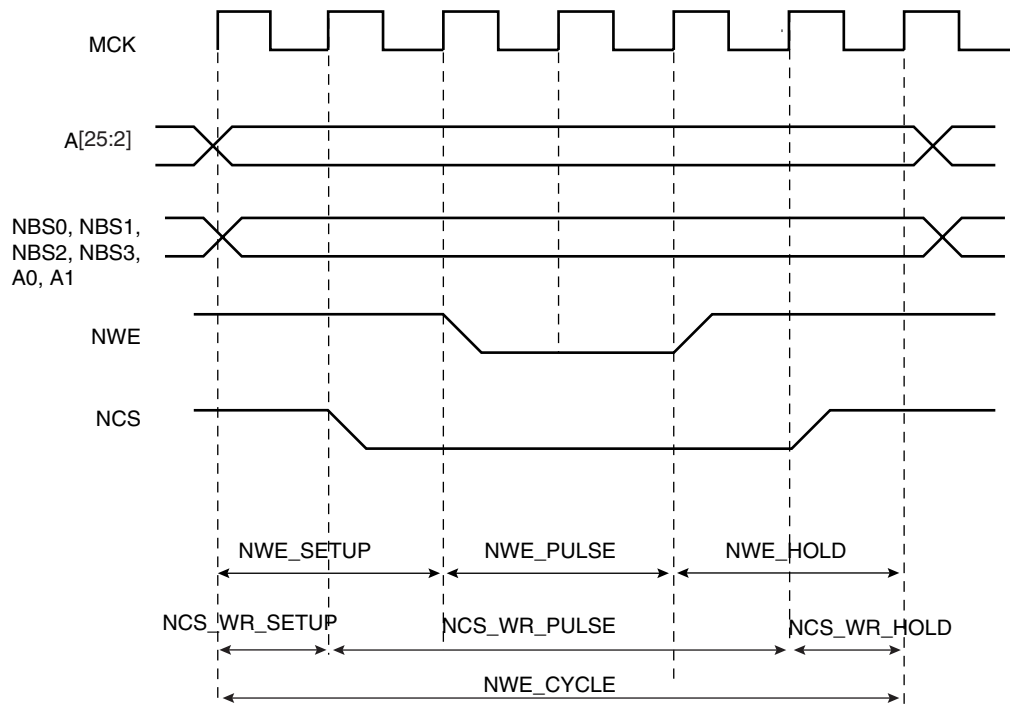

28.10.3.3 Write Cycle

The write_cycle time is defined as the total duration of the write cycle, that is, from the time where address is set on the address bus to the point where address may change. The total write cycle time is equal to:

$$\begin{aligned} \text{NWE_CYCLE} &= \text{NWE_SETUP} + \text{NWE_PULSE} + \text{NWE_HOLD} \\ &= \text{NCS_WR_SETUP} + \text{NCS_WR_PULSE} + \text{NCS_WR_HOLD} \end{aligned}$$

All NWE and NCS (write) timings are defined separately for each chip select as an integer number of Master Clock cycles. To ensure that the NWE and NCS timings are coherent, the user must define the total write cycle instead of the hold timing. This implicitly defines the NWE hold time and NCS (write) hold times as:

$$\begin{aligned} \text{NWE_HOLD} &= \text{NWE_CYCLE} - \text{NWE_SETUP} - \text{NWE_PULSE} \\ \text{NCS_WR_HOLD} &= \text{NWE_CYCLE} - \text{NCS_WR_SETUP} - \text{NCS_WR_PULSE} \end{aligned}$$

28.10.3.4 Null Delay Setup and Hold

If null setup parameters are programmed for NWE and/or NCS, NWE and/or NCS remain active continuously in case of consecutive write cycles in the same memory (see [Figure 28-14 on page 493](#)). However, for devices that perform write operations on the rising edge of NWE or NCS, such as SRAM, either a setup or a hold must be programmed.

Figure 28-14. Null Setup and Hold Values of NCS and NWE in Write Cycle

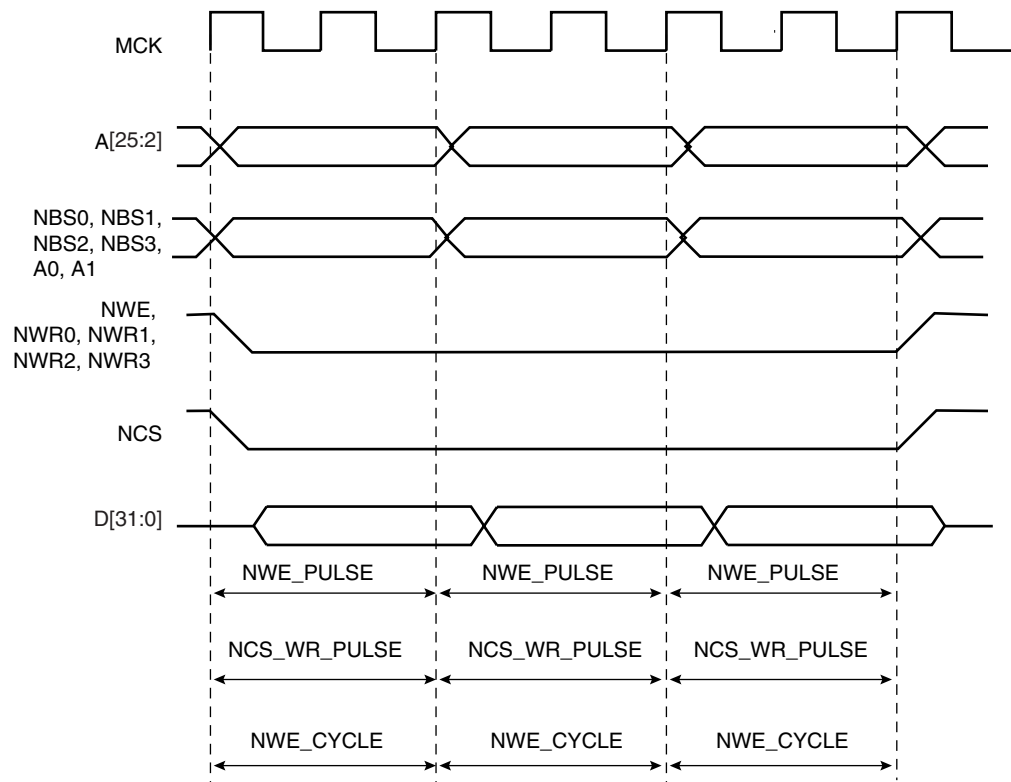

28.10.3.5 Null Pulse

Programming null pulse is not permitted. Pulse must be at least set to 1. A null value leads to unpredictable behavior.

28.10.4 Write Mode

The WRITE_MODE parameter in the MODE register of the corresponding chip select indicates which signal controls the write operation.

28.10.4.1 Write is Controlled by NWE (WRITE_MODE = 1):

Figure 28-15 on page 494 shows the waveforms of a write operation with WRITE_MODE set to 1. The data is put on the bus during the pulse and hold steps of the NWE signal. The internal data buffers are turned out after the NWE_SETUP time, and until the end of the write cycle, regardless of the programmed waveform on NCS.

Figure 28-15. WRITE_MODE = 1. The write operation is controlled by NWE

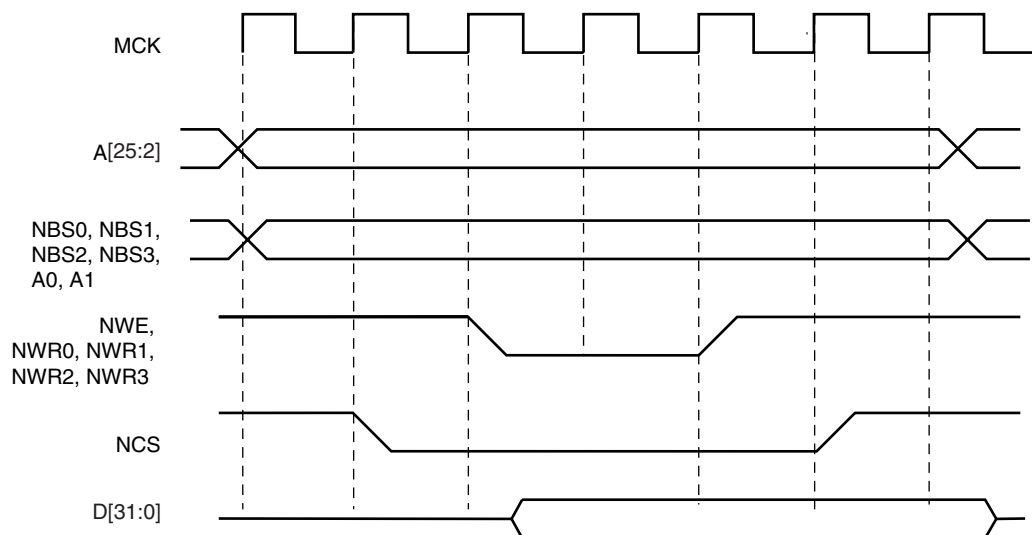

28.10.4.2 Write is Controlled by NCS (WRITE_MODE = 0)

Figure 28-16 on page 495 shows the waveforms of a write operation with WRITE_MODE set to 0. The data is put on the bus during the pulse and hold steps of the NCS signal. The internal data buffers are turned out after the NCS_WR_SETUP time, and until the end of the write cycle, regardless of the programmed waveform on NWE.

Figure 28-16. WRITE_MODE = 0. The write operation is controlled by NCS

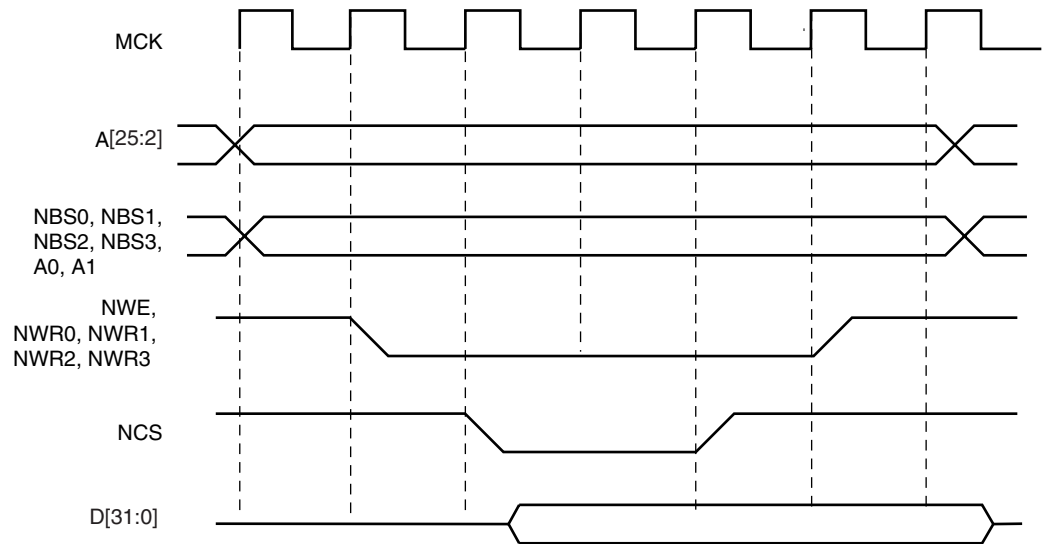

28.10.5 Coding Timing Parameters

All timing parameters are defined for one chip select and are grouped together in one SMC_REGISTER according to their type.

The SETUP register groups the definition of all setup parameters:

- NRD_SETUP, NCS_RD_SETUP, NWE_SETUP, NCS_WR_SETUP

The PULSE register groups the definition of all pulse parameters:

- NRD_PULSE, NCS_RD_PULSE, NWE_PULSE, NCS_WR_PULSE

The CYCLE register groups the definition of all cycle parameters:

- NRD_CYCLE, NWE_CYCLE

[Section 28-4 on page 495](#) shows how the timing parameters are coded and their permitted range.

Table 28-4. Coding and Range of Timing Parameters

Coded Value	Number of Bits	Effective Value	Permitted Range	
			Coded Value	Effective Value
setup [5:0]	6	$128 \times \text{setup}[5] + \text{setup}[4:0]$	$0 \leq \leq 31$	$128 \leq \leq 128+31$
pulse [6:0]	7	$256 \times \text{pulse}[6] + \text{pulse}[5:0]$	$0 \leq \leq 63$	$256 \leq \leq 256+63$
cycle [8:0]	9	$256 \times \text{cycle}[8:7] + \text{cycle}[6:0]$	$0 \leq \leq 127$	$256 \leq \leq 256+127$ $512 \leq \leq 512+127$ $768 \leq \leq 768+127$

28.10.6 Reset Values of Timing Parameters

[Section 28-5 on page 496](#) gives the default value of timing parameters at reset.

Table 28-5. Reset Values of Timing Parameters

Register	Reset Value	
SETUP	0x01010101	All setup timings are set to 1
PULSE	0x01010101	All pulse timings are set to 1
CYCLE	0x00030003	The read and write operation last 3 Master Clock cycles and provide one hold cycle
WRITE_MODE	1	Write is controlled with NWE
READ_MODE	1	Read is controlled with NRD

28.10.7 Usage Restriction

The SMC does not check the validity of the user-programmed parameters. If the sum of SETUP and PULSE parameters is larger than the corresponding CYCLE parameter, this leads to unpredictable behavior of the SMC.

For read operations:

Null but positive setup and hold of address and NRD and/or NCS can not be guaranteed at the memory interface because of the propagation delay of these signals through external logic and pads. If positive setup and hold values must be verified, then it is strictly recommended to program non-null values so as to cover possible skews between address, NCS and NRD signals.

For write operations:

If a null hold value is programmed on NWE, the SMC can guarantee a positive hold of address, byte select lines, and NCS signal after the rising edge of NWE. This is true for WRITE_MODE = 1 only. See ["Early Read Wait State" on page 497](#).

For read and write operations: a null value for pulse parameters is forbidden and may lead to unpredictable behavior.

In read and write cycles, the setup and hold time parameters are defined in reference to the address bus. For external devices that require setup and hold time between NCS and NRD signals (read), or between NCS and NWE signals (write), these setup and hold times must be converted into setup and hold times in reference to the address bus.

28.11 Automatic Wait States

Under certain circumstances, the SMC automatically inserts idle cycles between accesses to avoid bus contention or operation conflict.

28.11.1 Chip Select Wait States

The SMC always inserts an idle cycle between 2 transfers on separate chip selects. This idle cycle ensures that there is no bus contention between the de-activation of one device and the activation of the next one.

During chip select wait state, all control lines are turned inactive: NBS0 to NBS3, NWR0 to NWR3, NCS[0..NB_CS-1], NRD lines are all set to 1.

[Figure 28-17 on page 497](#) illustrates a chip select wait state between access on Chip Select 0 and Chip Select 2.

Figure 28-17. Chip Select Wait State between a Read Access on NCS0 and a Write Access on NCS2

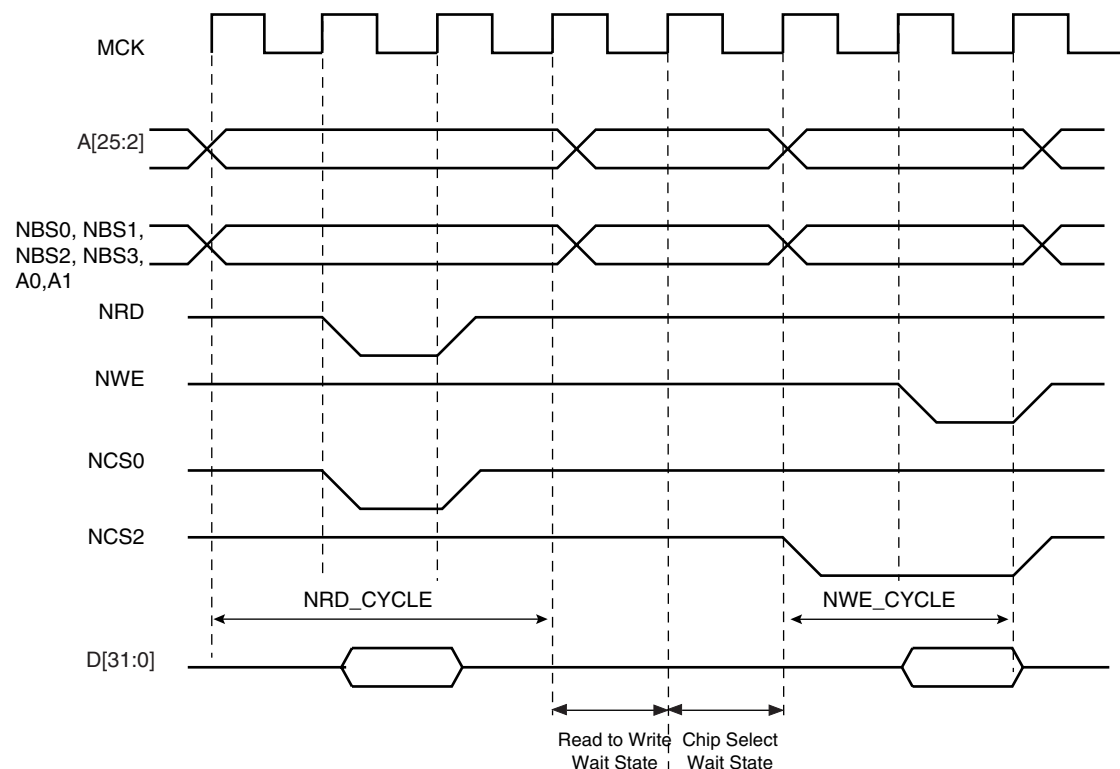

28.11.2 Early Read Wait State

In some cases, the SMC inserts a wait state cycle between a write access and a read access to allow time for the write cycle to end before the subsequent read cycle begins. This wait state is not generated in addition to a chip select wait state. The early read cycle thus only occurs between a write and read access to the same memory device (same chip select).

An early read wait state is automatically inserted if at least one of the following conditions is valid:

- if the write controlling signal has no hold time and the read controlling signal has no setup time ([Figure 28-18 on page 498](#)).
- in NCS write controlled mode (`WRITE_MODE = 0`), if there is no hold timing on the NCS signal and the `NCS_RD_SETUP` parameter is set to 0, regardless of the read mode ([Figure 28-19 on page 498](#)). The write operation must end with a NCS rising edge. Without an Early Read Wait State, the write operation could not complete properly.
- in NWE controlled mode (`WRITE_MODE = 1`) and if there is no hold timing (`NWE_HOLD = 0`), the feedback of the write control signal is used to control address, data, chip select and byte select lines. If the external write control signal is not inactivated as expected due to load capacitances, an Early Read Wait State is inserted and address, data and control signals are maintained one more cycle. See [Figure 28-20 on page 499](#).

Figure 28-18. Early Read Wait State: Write with No Hold Followed by Read with No Setup

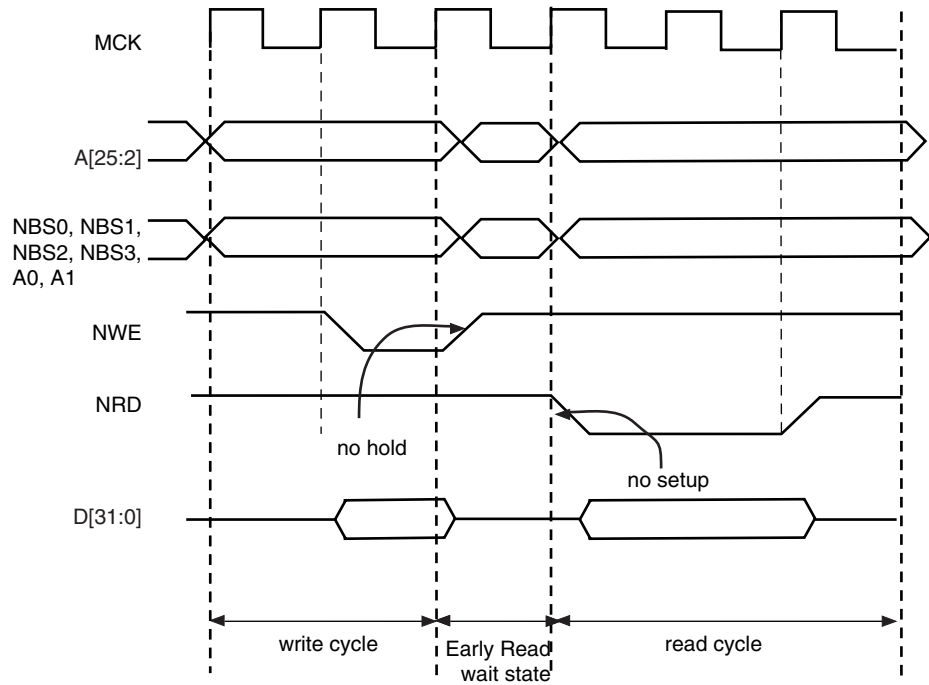
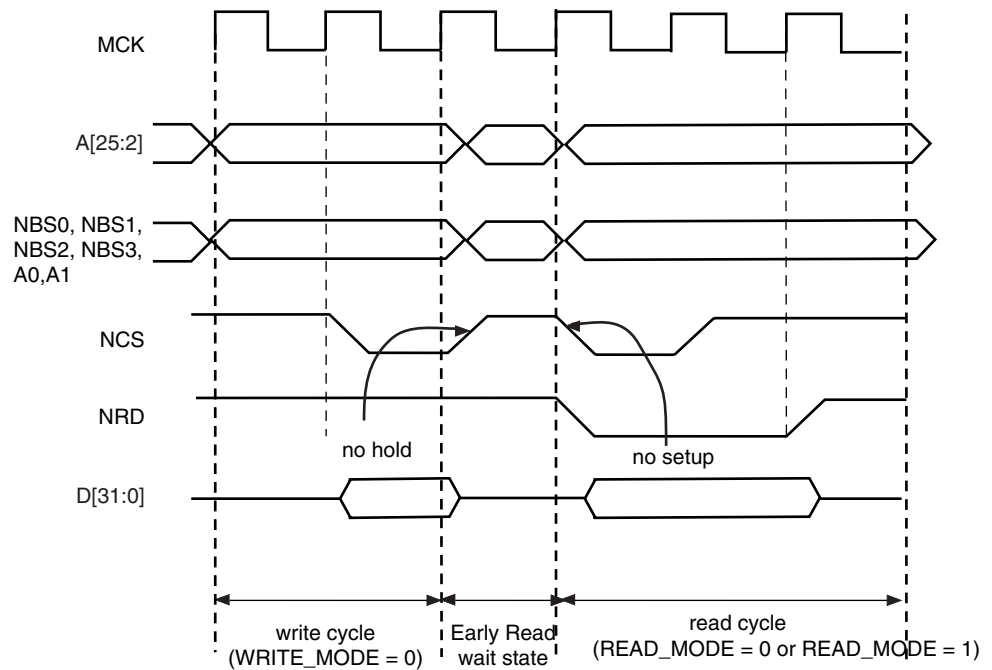
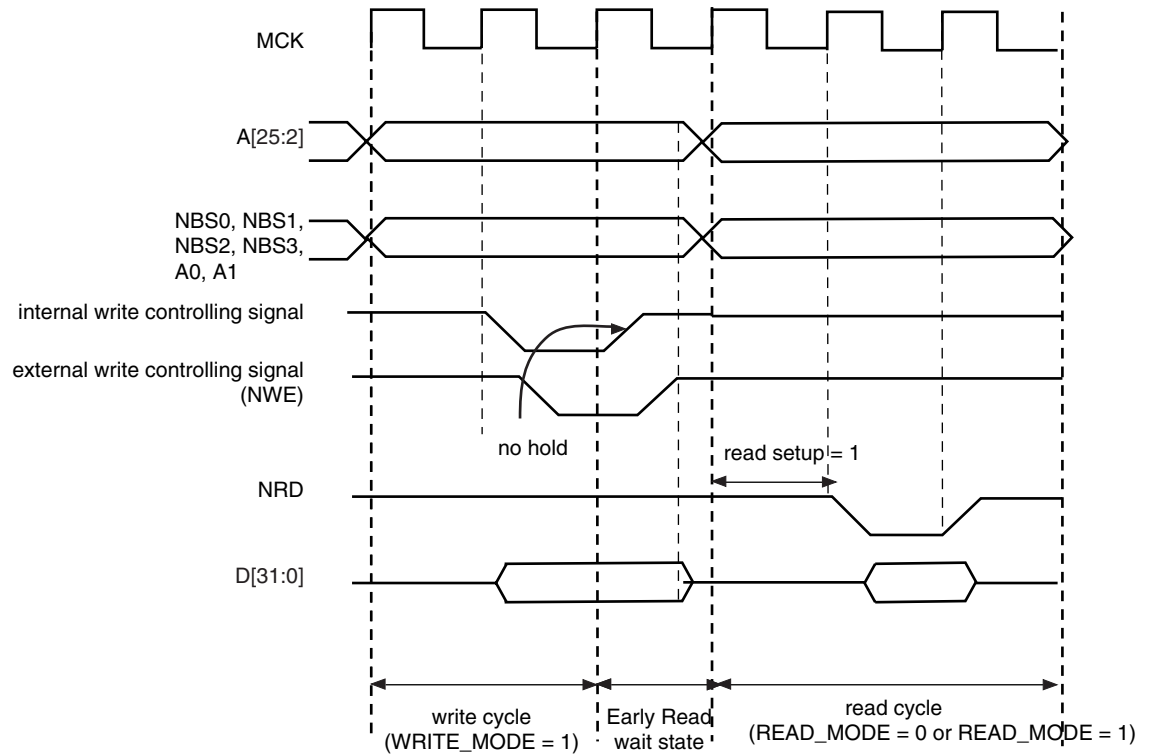

Figure 28-19. Early Read Wait State: NCS Controlled Write with No Hold Followed by a Read



with No NCS Setup

Figure 28-20. Early Read Wait State: NWE-controlled Write with No Hold Followed by a Read



with one Set-up Cycle

28.11.3 Reload User Configuration Wait State

The user may change any of the configuration parameters by writing the SMC user interface.

When detecting that a new user configuration has been written in the user interface, the SMC inserts a wait state before starting the next access. The so called “Reload User Configuration Wait State” is used by the SMC to load the new set of parameters to apply to next accesses.

The Reload Configuration Wait State is not applied in addition to the Chip Select Wait State. If accesses before and after re-programming the user interface are made to different devices (Chip Selects), then one single Chip Select Wait State is applied.

On the other hand, if accesses before and after writing the user interface are made to the same device, a Reload Configuration Wait State is inserted, even if the change does not concern the current Chip Select.

28.11.3.1 User Procedure

To insert a Reload Configuration Wait State, the SMC detects a write access to any MODE register of the user interface. If the user only modifies timing registers (SETUP, PULSE, CYCLE registers) in the user interface, he must validate the modification by writing the MODE, even if no change was made on the mode parameters.

28.11.3.2 Slow Clock Mode Transition

A Reload Configuration Wait State is also inserted when the Slow Clock Mode is entered or exited, after the end of the current transfer (see “Slow Clock Mode” on page 511).

28.11.4 Read to Write Wait State

Due to an internal mechanism, a wait cycle is always inserted between consecutive read and write SMC accesses.

This wait cycle is referred to as a read to write wait state in this document.

This wait cycle is applied in addition to chip select and reload user configuration wait states when they are to be inserted. See [Figure 28-17 on page 497](#).

28.12 Data Float Wait States

Some memory devices are slow to release the external bus. For such devices, it is necessary to add wait states (data float wait states) after a read access:

- before starting a read access to a different external memory
- before starting a write access to the same device or to a different external one.

The Data Float Output Time (t_{DF}) for each external memory device is programmed in the TDF_CYCLES field of the MODE register for the corresponding chip select. The value of TDF_CYCLES indicates the number of data float wait cycles (between 0 and 15) before the external device releases the bus, and represents the time allowed for the data output to go to high impedance after the memory is disabled.

Data float wait states do not delay internal memory accesses. Hence, a single access to an external memory with long t_{DF} will not slow down the execution of a program from internal memory.

The data float wait states management depends on the READ_MODE and the TDF_MODE fields of the MODE register for the corresponding chip select.

28.12.1 READ_MODE

Setting the READ_MODE to 1 indicates to the SMC that the NRD signal is responsible for turning off the tri-state buffers of the external memory device. The Data Float Period then begins after the rising edge of the NRD signal and lasts TDF_CYCLES MCK cycles.

When the read operation is controlled by the NCS signal (READ_MODE = 0), the TDF field gives the number of MCK cycles during which the data bus remains busy after the rising edge of NCS.

[Figure 28-21 on page 502](#) illustrates the Data Float Period in NRD-controlled mode (READ_MODE = 1), assuming a data float period of 2 cycles (TDF_CYCLES = 2). [Figure 28-22 on page 502](#) shows the read operation when controlled by NCS (READ_MODE = 0) and the TDF_CYCLES parameter equals 3.

Figure 28-21. TDF Period in NRD Controlled Read Access (TDF = 2)

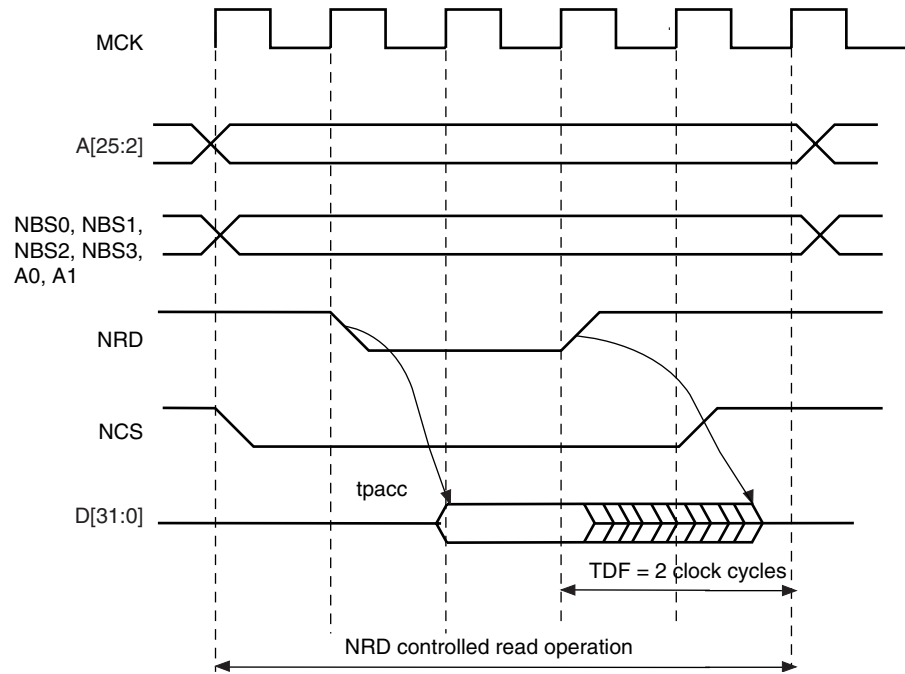
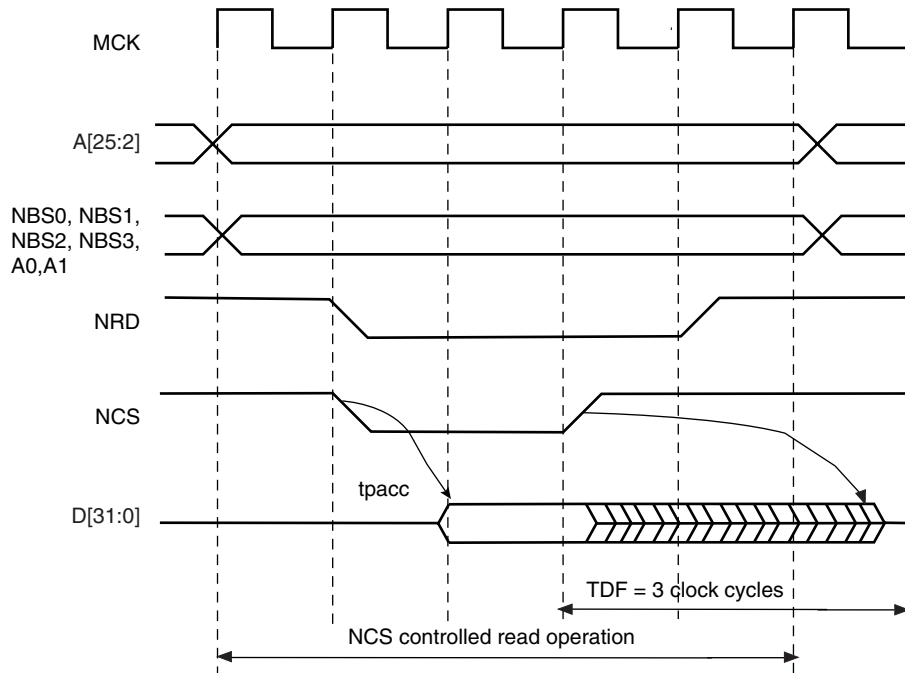

Figure 28-22. TDF Period in NCS Controlled Read Operation (TDF = 3)



28.12.2 TDF Optimization Enabled (TDF_MODE = 1)

When the TDF_MODE of the MODE register is set to 1 (TDF optimization is enabled), the SMC takes advantage of the setup period of the next access to optimize the number of wait states cycle to insert.

Figure 28-23 on page 503 shows a read access controlled by NRD, followed by a write access controlled by NWE, on Chip Select 0. Chip Select 0 has been programmed with:

NRD_HOLD = 4; READ_MODE = 1 (NRD controlled)

NWE_SETUP = 3; WRITE_MODE = 1 (NWE controlled)

TDF_CYCLES = 6; TDF_MODE = 1 (optimization enabled).

Figure 28-23. TDF Optimization: No TDF wait states are inserted if the TDF period is over when the next access begins

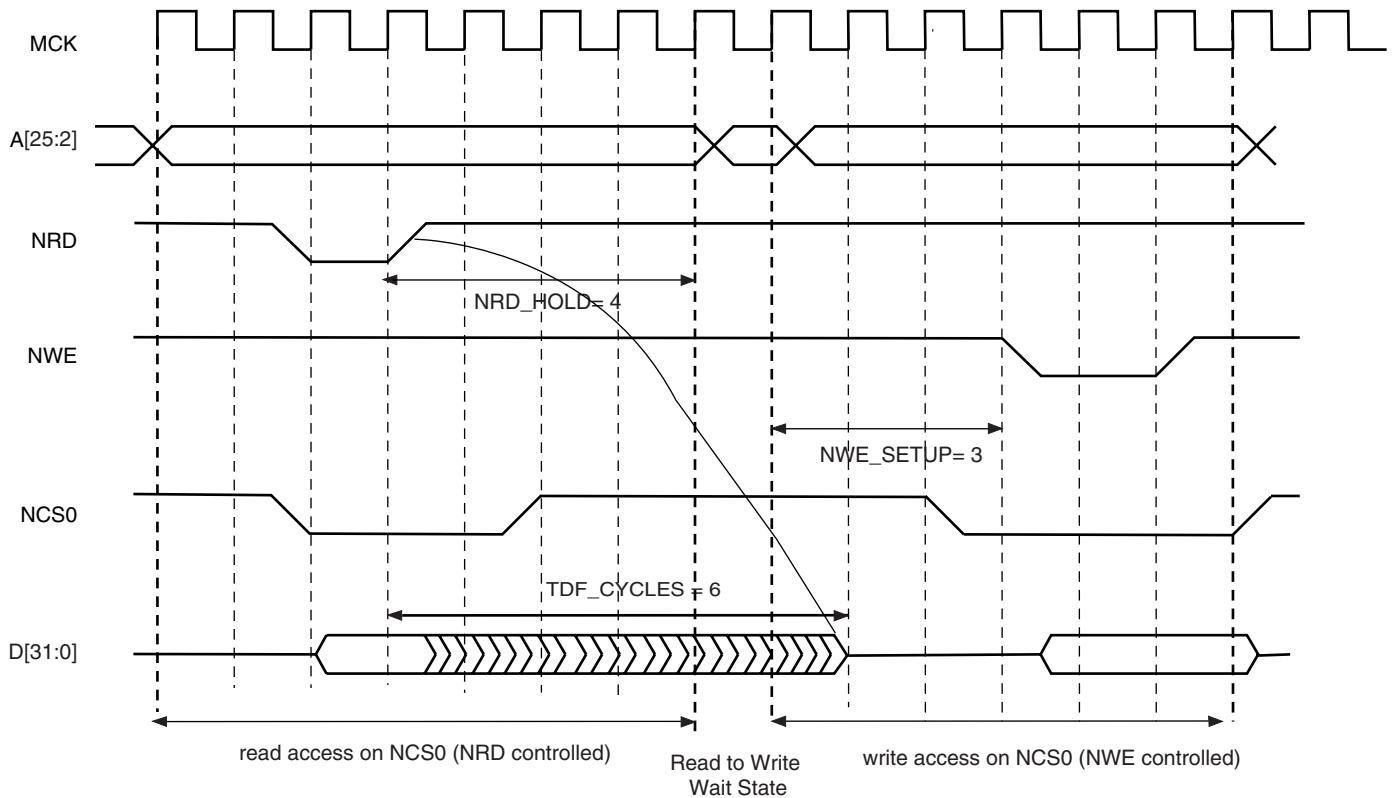

28.12.3 TDF Optimization Disabled (TDF_MODE = 0)

When optimization is disabled, tdf wait states are inserted at the end of the read transfer, so that the data float period is ended when the second access begins. If the hold period of the read1 controlling signal overlaps the data float period, no additional tdf wait states will be inserted.

Figure 28-24 on page 504, Figure 28-25 on page 504 and Figure 28-26 on page 505 illustrate the cases:

- read access followed by a read access on another chip select,
 - read access followed by a write access on another chip select,
 - read access followed by a write access on the same chip select,
- with no TDF optimization.

Figure 28-24. TDF Optimization Disabled (TDF Mode = 0). TDF wait states between 2 read accesses on different chip selects

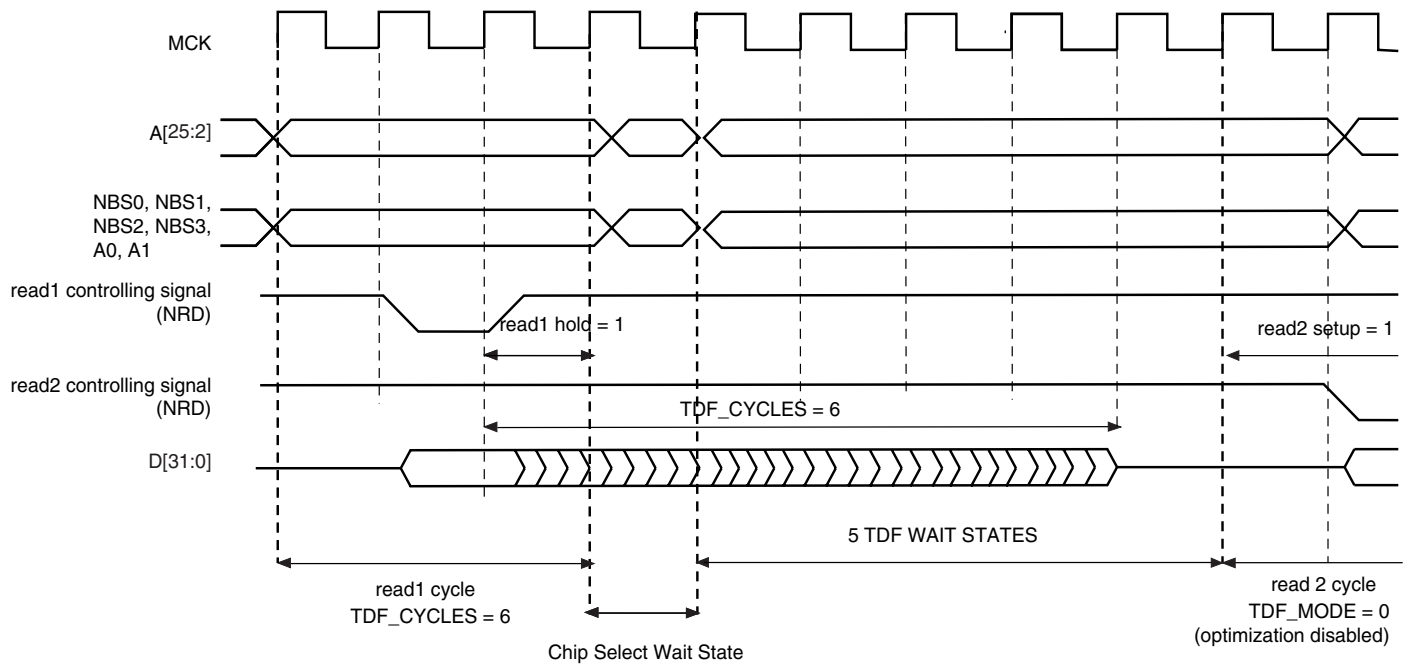

Figure 28-25. TDF Mode = 0: TDF wait states between a read and a write access on different chip selects

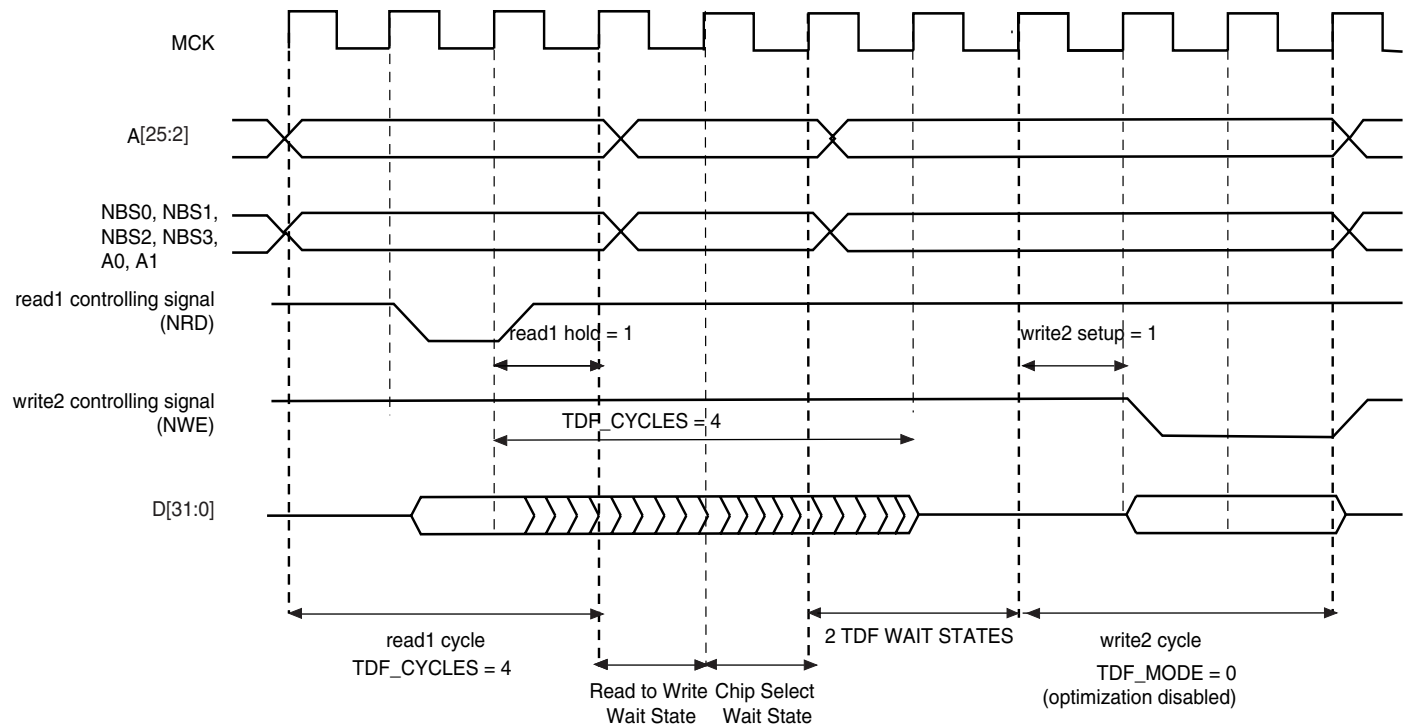
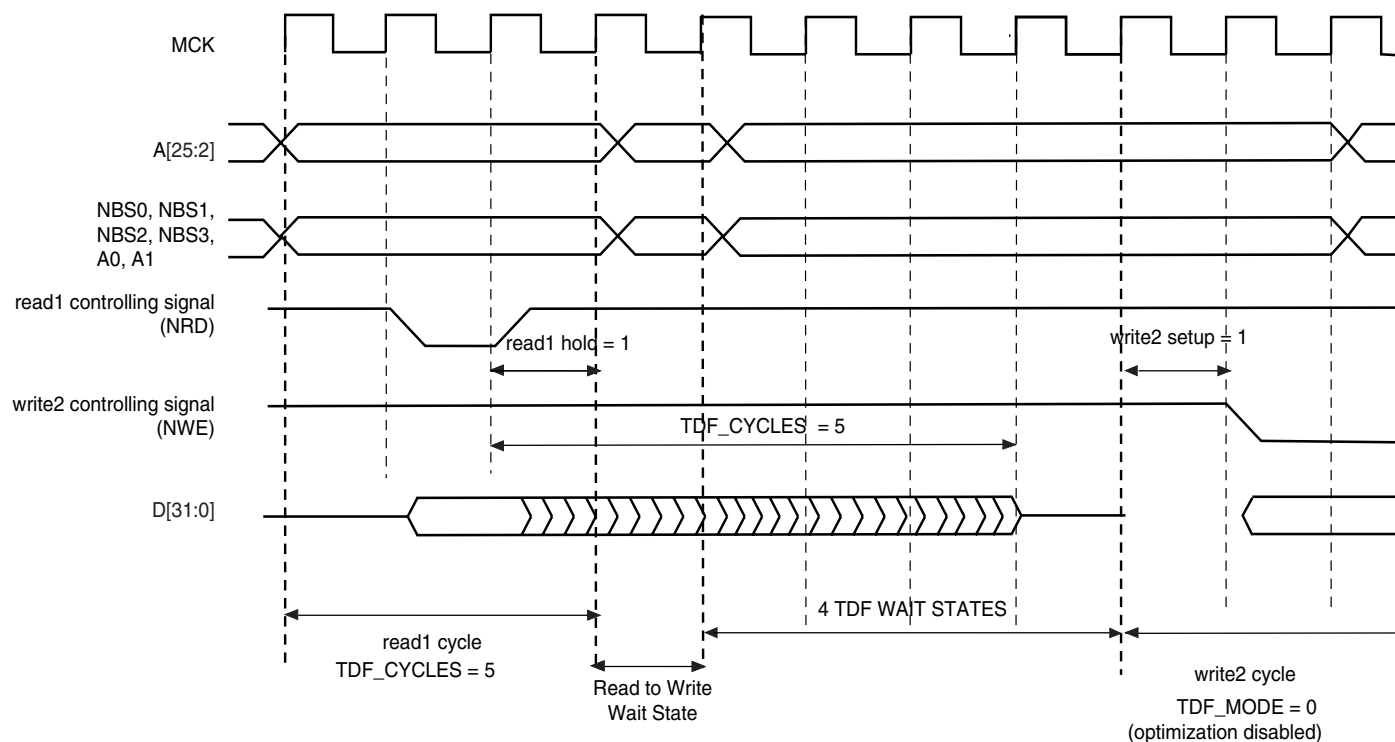

Figure 28-26. TDF Mode = 0: TDF wait states between read and write accesses on the same chip select



28.13 External Wait

Any access can be extended by an external device using the NWAIT input signal of the SMC. The EXNW_MODE field of the MODE register on the corresponding chip select must be set to either to “10” (frozen mode) or “11” (ready mode). When the EXNW_MODE is set to “00” (disabled), the NWAIT signal is simply ignored on the corresponding chip select. The NWAIT signal delays the read or write operation in regards to the read or write controlling signal, depending on the read and write modes of the corresponding chip select.

28.13.1 Restriction

When one of the EXNW_MODE is enabled, it is mandatory to program at least one hold cycle for the read/write controlling signal. For that reason, the NWAIT signal cannot be used in Page Mode (“Asynchronous Page Mode” on page 514), or in Slow Clock Mode (“Slow Clock Mode” on page 511).

The NWAIT signal is assumed to be a response of the external device to the read/write request of the SMC. Then NWAIT is examined by the SMC only in the pulse state of the read or write controlling signal. The assertion of the NWAIT signal outside the expected period has no impact on SMC behavior.

28.13.2 Frozen Mode

When the external device asserts the NWAIT signal (active low), and after internal synchronization of this signal, the SMC state is frozen, i.e., SMC internal counters are frozen, and all control signals remain unchanged. When the resynchronized NWAIT signal is deasserted, the SMC completes the access, resuming the access from the point where it was stopped. See [Figure 28-27 on page 506](#). This mode must be selected when the external device uses the NWAIT signal to delay the access and to freeze the SMC.

The assertion of the NWAIT signal outside the expected period is ignored as illustrated in [Figure 28-28 on page 507](#).

Figure 28-27. Write Access with NWAIT Assertion in Frozen Mode (EXNW_MODE = 10)

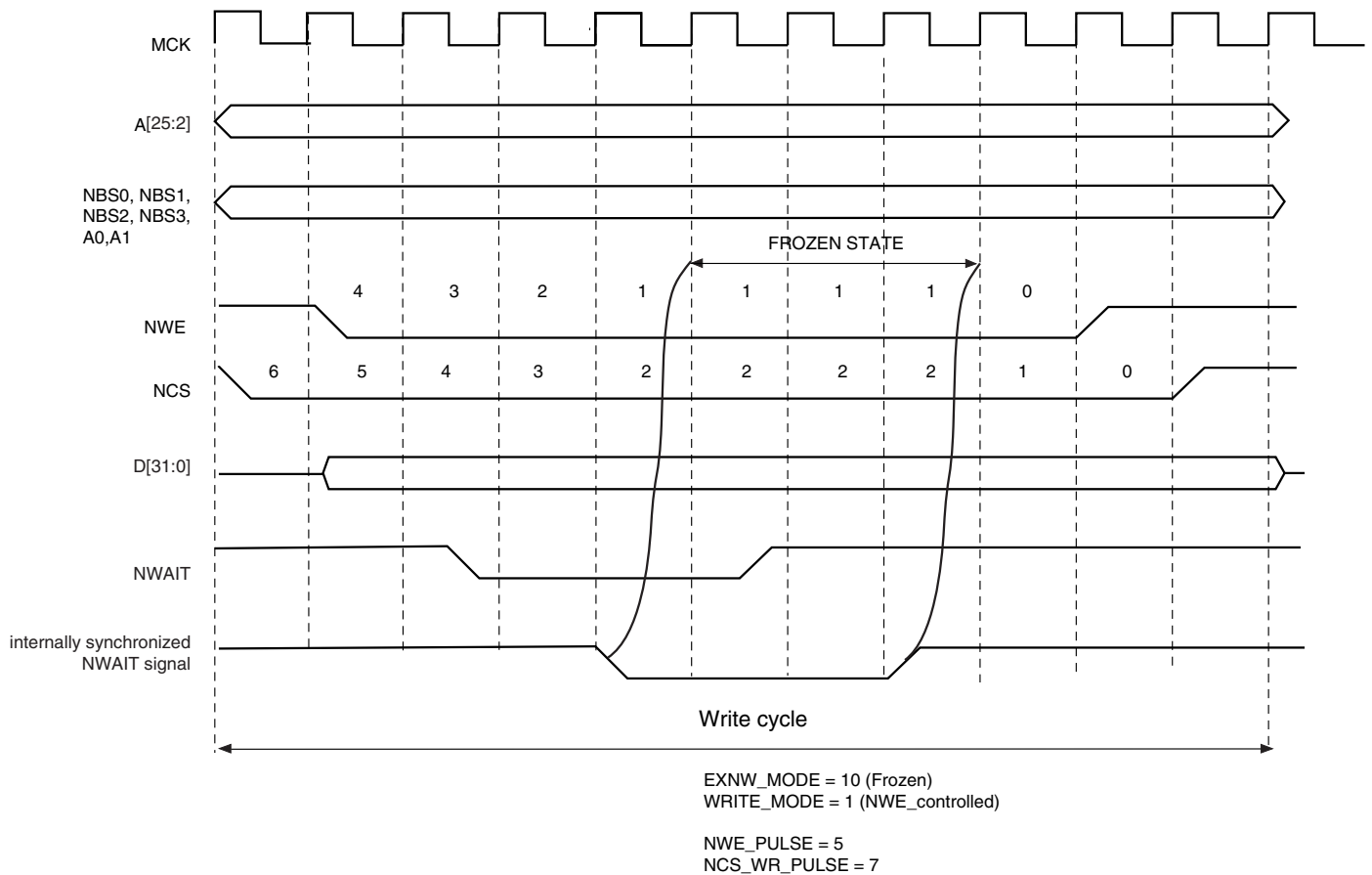
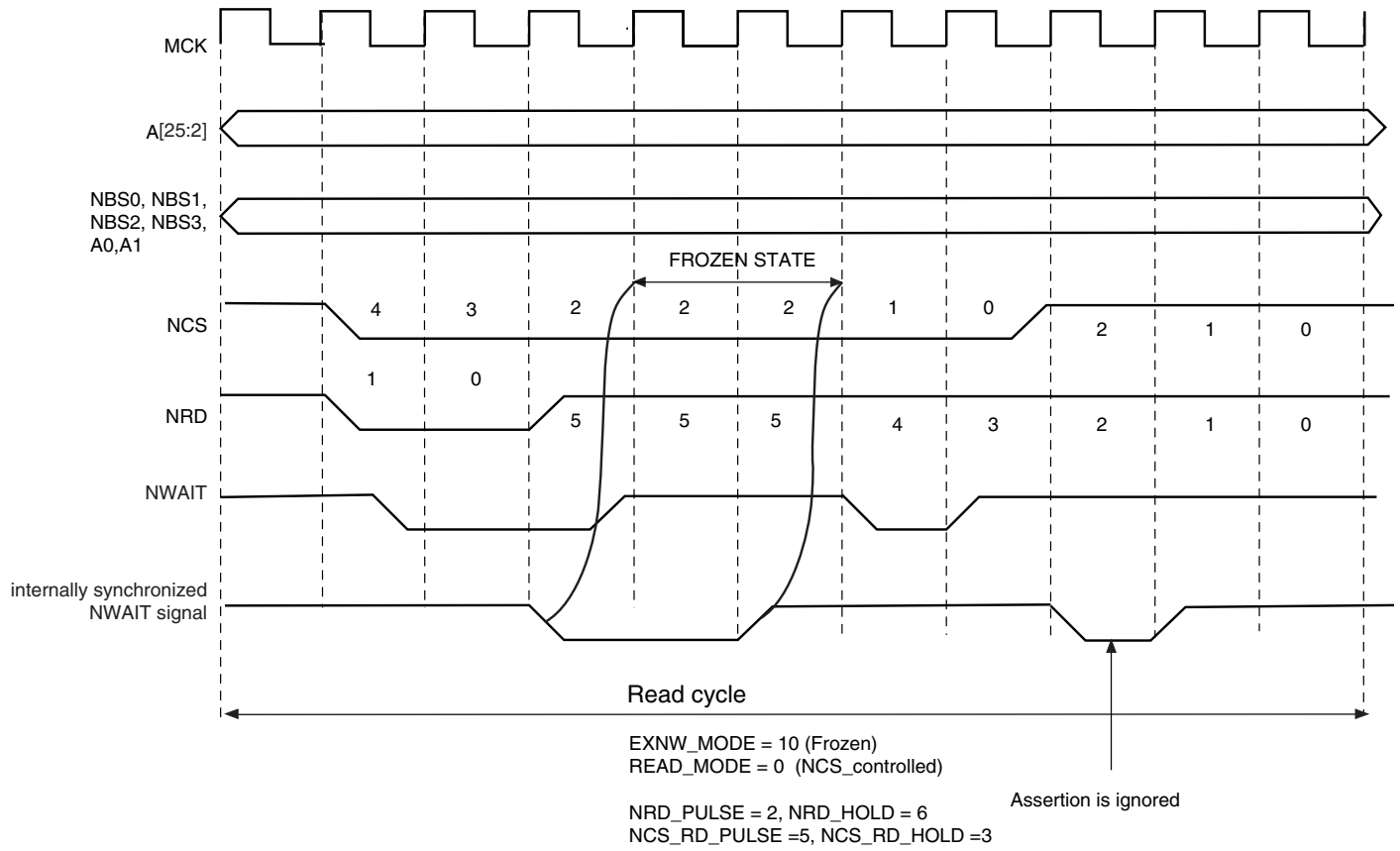

Figure 28-28. Read Access with NWAIT Assertion in Frozen Mode (EXNW_MODE = 10)



28.13.3 Ready Mode

In Ready mode ($EXNW_MODE = 11$), the SMC behaves differently. Normally, the SMC begins the access by down counting the setup and pulse counters of the read/write controlling signal. In the last cycle of the pulse phase, the resynchronized NWAIT signal is examined.

If asserted, the SMC suspends the access as shown in [Figure 28-29 on page 508](#) and [Figure 28-30 on page 509](#). After deassertion, the access is completed: the hold step of the access is performed.

This mode must be selected when the external device uses deassertion of the NWAIT signal to indicate its ability to complete the read or write operation.

If the NWAIT signal is deasserted before the end of the pulse, or asserted after the end of the pulse of the controlling read/write signal, it has no impact on the access length as shown in [Figure 28-30 on page 509](#).

Figure 28-29. NWAIT Assertion in Write Access: Ready Mode ($EXNW_MODE = 11$)

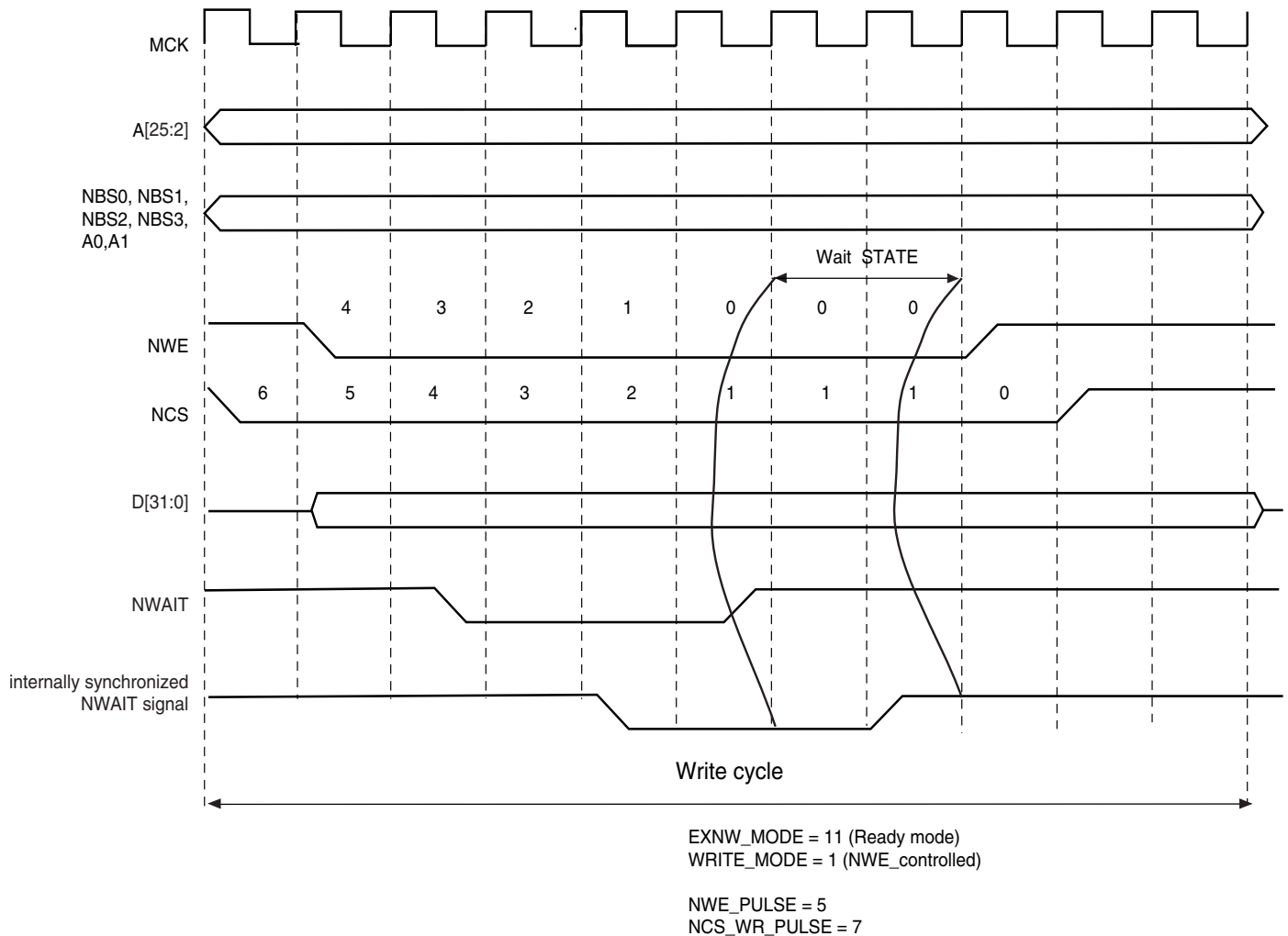
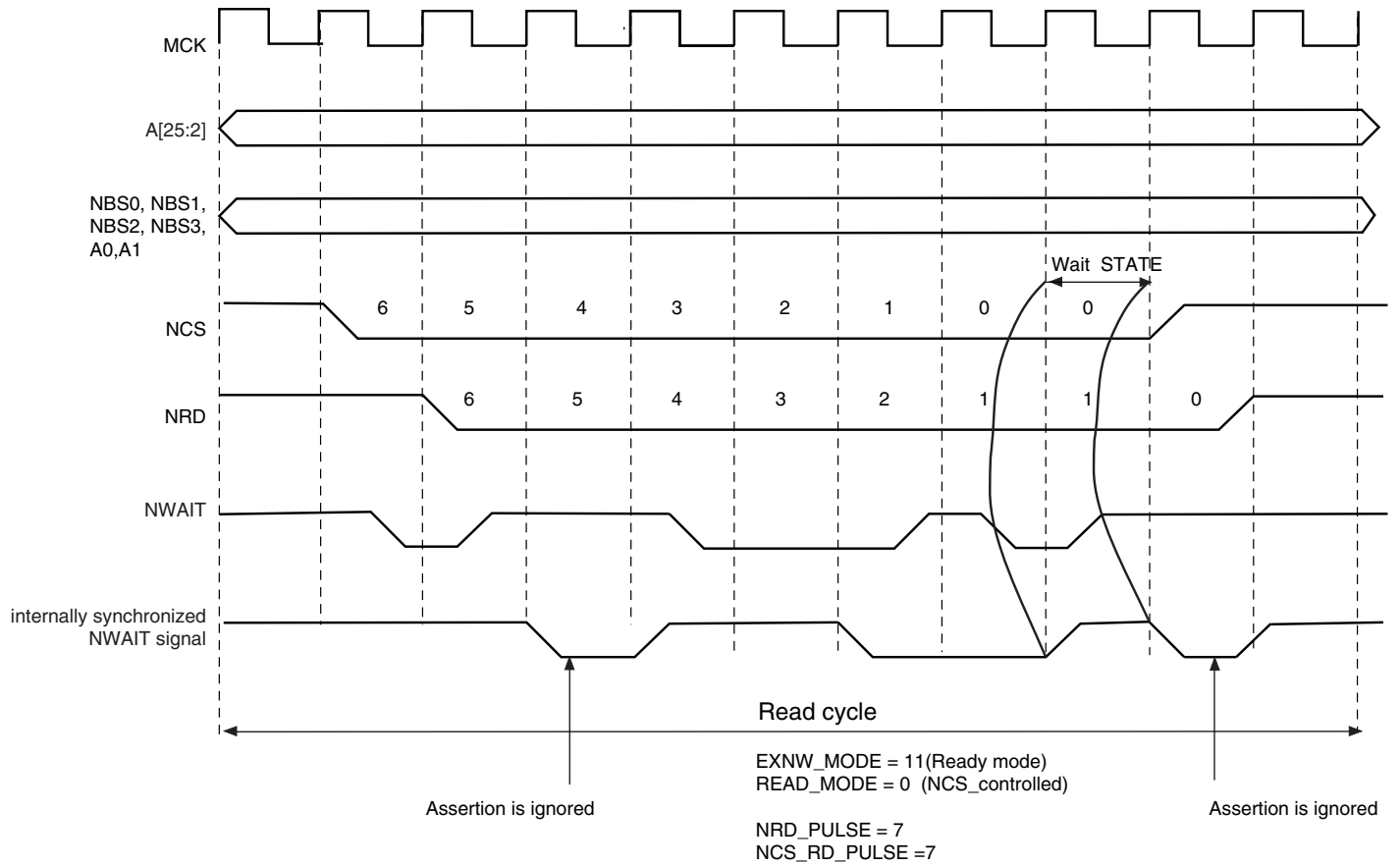

Figure 28-30. NWAIT Assertion in Read Access: Ready Mode (EXNW_MODE = 11)



28.13.4 NWAIT Latency and Read/write Timings

There may be a latency between the assertion of the read/write controlling signal and the assertion of the NWAIT signal by the device. The programmed pulse length of the read/write controlling signal must be at least equal to this latency plus the 2 cycles of resynchronization + 1 cycle. Otherwise, the SMC may enter the hold state of the access without detecting the NWAIT signal assertion. This is true in frozen mode as well as in ready mode. This is illustrated on Figure 28-31 on page 510.

When EXNW_MODE is enabled (ready or frozen), the user must program a pulse length of the read and write controlling signal of at least:

$$\text{minimal pulse length} = \text{NWAIT latency} + 2 \text{ resynchronization cycles} + 1 \text{ cycle}$$

Figure 28-31. NWAIT Latency

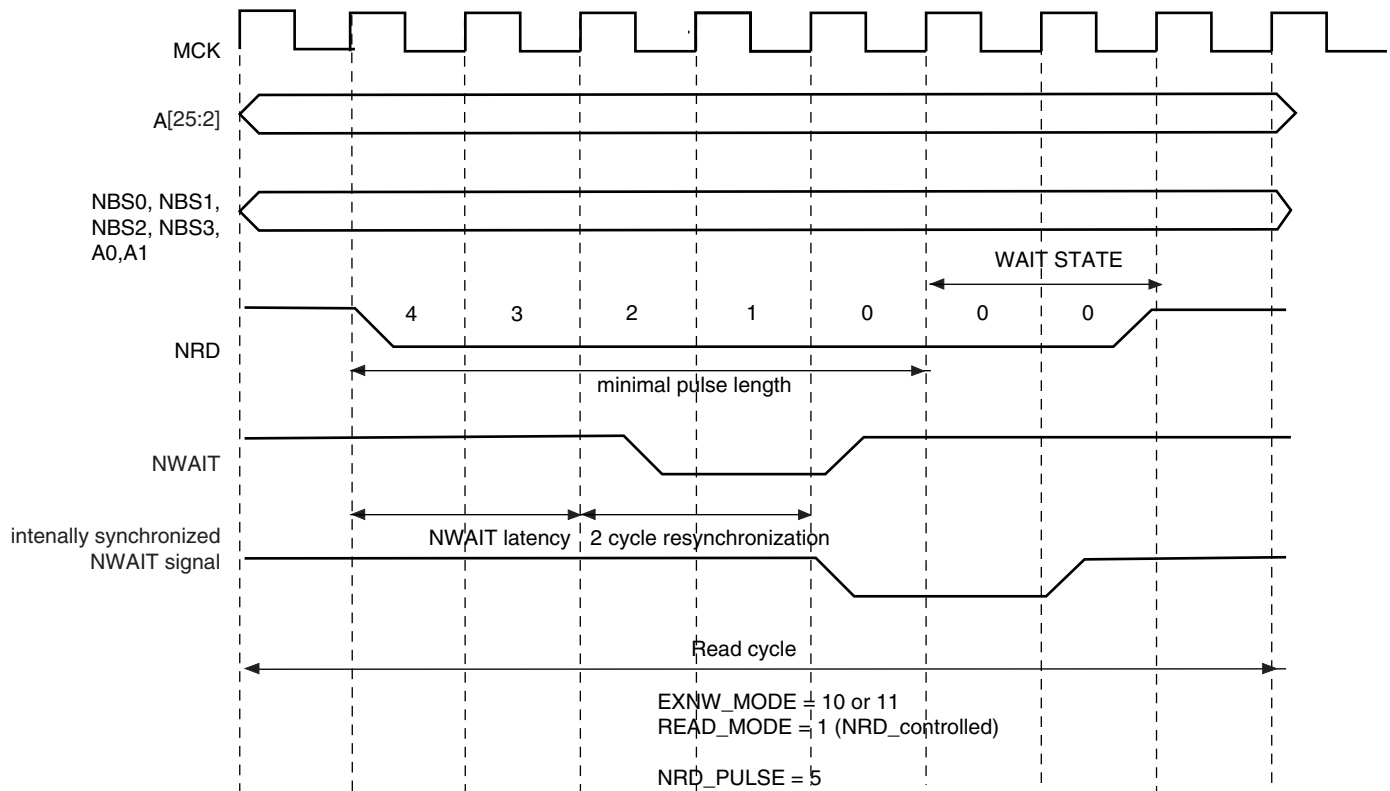

28.14 Slow Clock Mode

The SMC is able to automatically apply a set of “slow clock mode” read/write waveforms when an internal signal driven by the Power Management Controller is asserted because MCK has been turned to a slow clock rate (typically 32 kHz clock rate). In this mode, the user-programmed waveforms are ignored and the slow clock mode waveforms are applied. This mode is provided so as to avoid reprogramming the User Interface with appropriate waveforms at very slow clock rate. When activated, the slow mode is active on all chip selects.

28.14.1 Slow Clock Mode Waveforms

Figure 28-32 on page 511 illustrates the read and write operations in slow clock mode. They are valid on all chip selects. Section 28-6 on page 511 indicates the value of read and write parameters in slow clock mode.

Figure 28-32. Read/write Cycles in Slow Clock Mode

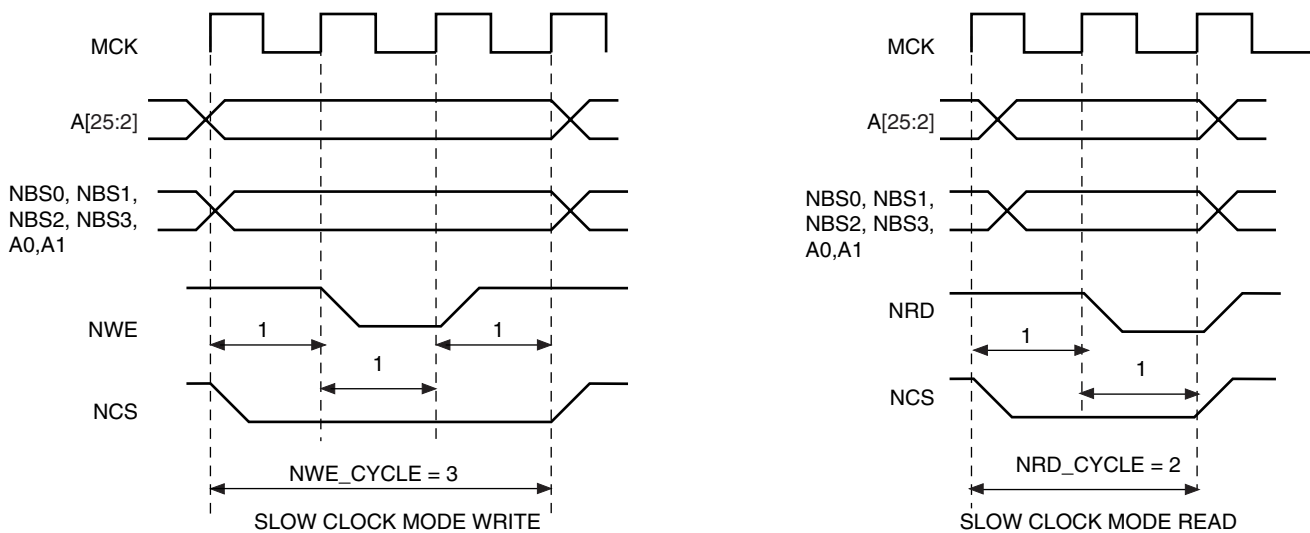

Table 28-6. Read and Write Timing Parameters in Slow Clock Mode

Read Parameters	Duration (cycles)	Write Parameters	Duration (cycles)
NRD_SETUP	1	NWE_SETUP	1
NRD_PULSE	1	NWE_PULSE	1
NCS_RD_SETUP	0	NCS_WR_SETUP	0
NCS_RD_PULSE	2	NCS_WR_PULSE	3
NRD_CYCLE	2	NWE_CYCLE	3

28.14.2 Switching from (to) Slow Clock Mode to (from) Normal Mode

When switching from slow clock mode to the normal mode, the current slow clock mode transfer is completed at high clock rate, with the set of slow clock mode parameters. See [Figure 28-33 on page 512](#). The external device may not be fast enough to support such timings.

[Figure 28-34 on page 513](#) illustrates the recommended procedure to properly switch from one mode to the other.

Figure 28-33. Clock Rate Transition Occurs while the SMC is Performing a Write Operation

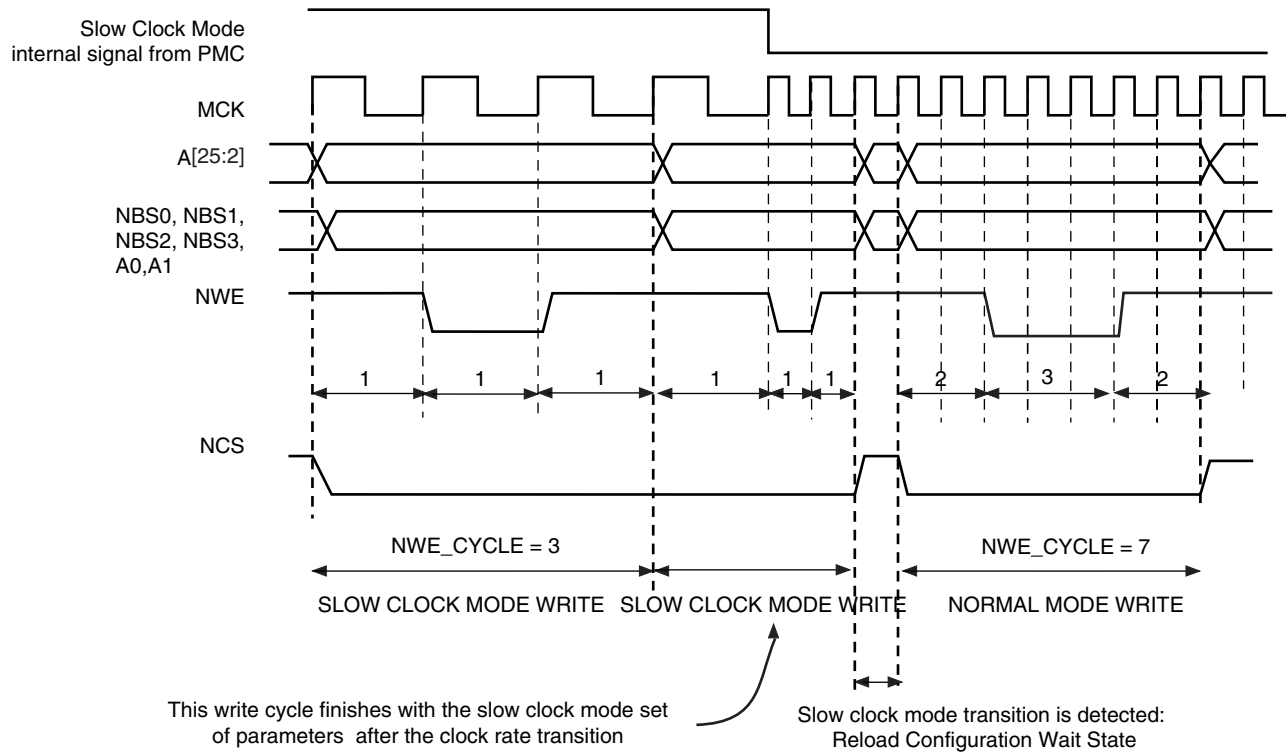
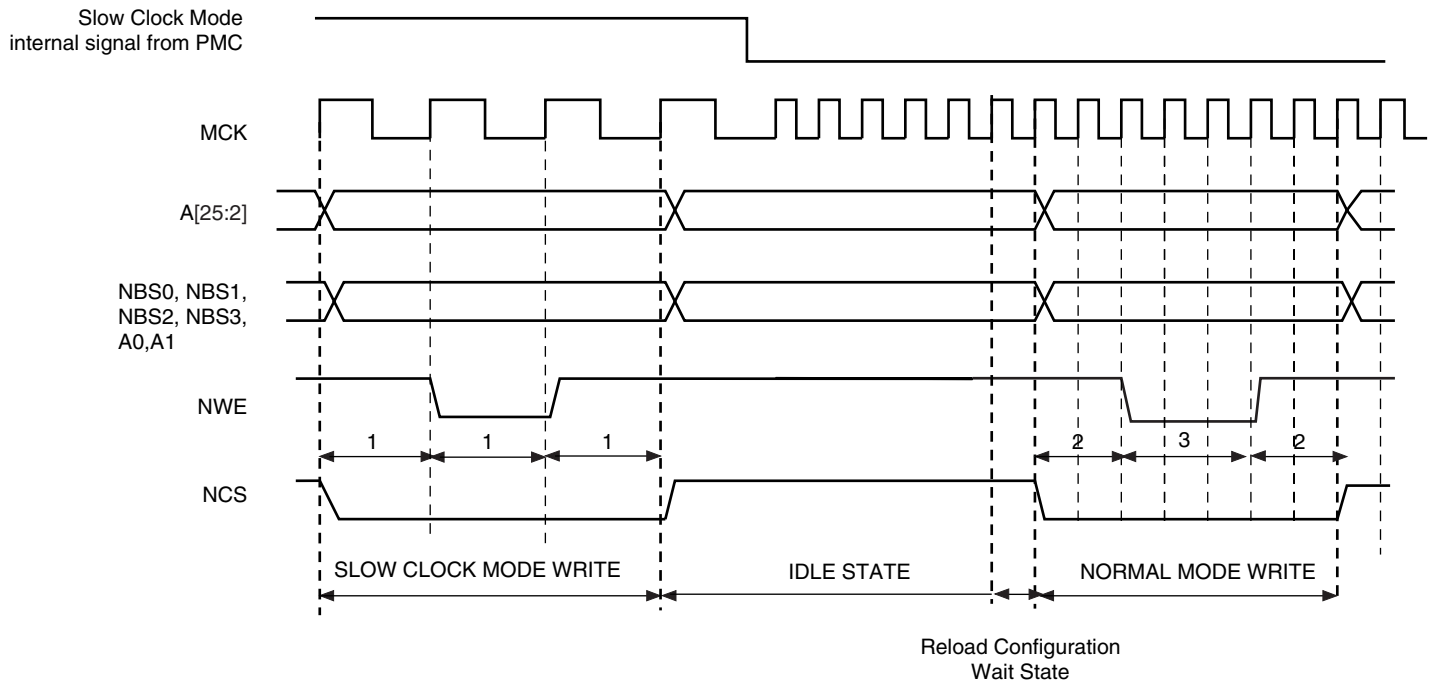

Figure 28-34. Recommended Procedure to Switch from Slow Clock Mode to Normal Mode or from Normal Mode to Slow Clock Mode



28.15 Asynchronous Page Mode

The SMC supports asynchronous burst reads in page mode, providing that the page mode is enabled in the MODE register (PMEN field). The page size must be configured in the MODE register (PS field) to 4, 8, 16 or 32 bytes.

The page defines a set of consecutive bytes into memory. A 4-byte page (resp. 8-, 16-, 32-byte page) is always aligned to 4-byte boundaries (resp. 8-, 16-, 32-byte boundaries) of memory. The MSB of data address defines the address of the page in memory, the LSB of address define the address of the data in the page as detailed in [Table 28-7 on page 514](#).

With page mode memory devices, the first access to one page (t_{pa}) takes longer than the subsequent accesses to the page (t_{sa}) as shown in [Figure 28-35 on page 514](#). When in page mode, the SMC enables the user to define different read timings for the first access within one page, and next accesses within the page.

Table 28-7. Page Address and Data Address within a Page

Page Size	Page Address ⁽¹⁾	Data Address in the Page ⁽²⁾
4 bytes	A[25:2]	A[1:0]
8 bytes	A[25:3]	A[2:0]
16 bytes	A[25:4]	A[3:0]
32 bytes	A[25:5]	A[4:0]

- Notes: 1. A denotes the address bus of the memory device
 2. For 16-bit devices, the bit 0 of address is ignored. For 32-bit devices, bits [1:0] are ignored.

28.15.1 Protocol and Timings in Page Mode

[Figure 28-35 on page 514](#) shows the NRD and NCS timings in page mode access.

Figure 28-35. Page Mode Read Protocol (Address MSB and LSB are defined in [Table 28-7 on page 514](#))

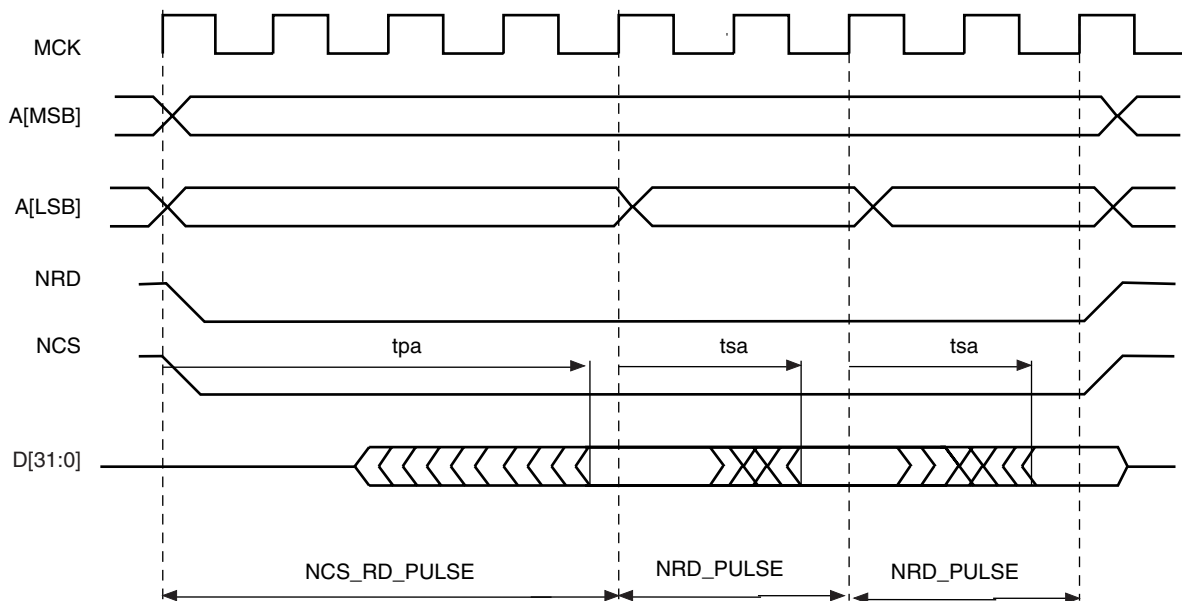

The NRD and NCS signals are held low during all read transfers, whatever the programmed values of the setup and hold timings in the User Interface may be. Moreover, the NRD and NCS timings are identical. The pulse length of the first access to the page is defined with the

NCS_RD_PULSE field of the PULSE register. The pulse length of subsequent accesses within the page are defined using the NRD_PULSE parameter.

In page mode, the programming of the read timings is described in [Table 28-8 on page 515](#):

Table 28-8. Programming of Read Timings in Page Mode

Parameter	Value	Definition
READ_MODE	'x'	No impact
NCS_RD_SETUP	'x'	No impact
NCS_RD_PULSE	t_{pa}	Access time of first access to the page
NRD_SETUP	'x'	No impact
NRD_PULSE	t_{sa}	Access time of subsequent accesses in the page
NRD_CYCLE	'x'	No impact

The SMC does not check the coherency of timings. It will always apply the NCS_RD_PULSE timings as page access timing (t_{pa}) and the NRD_PULSE for accesses to the page (t_{sa}), even if the programmed value for t_{pa} is shorter than the programmed value for t_{sa} .

28.15.2 Byte Access Type in Page Mode

The Byte Access Type configuration remains active in page mode. For 16-bit or 32-bit page mode devices that require byte selection signals, configure the BAT field of the SMC_REGISTER to 0 (byte select access type).

28.15.3 Page Mode Restriction

The page mode is not compatible with the use of the NWAIT signal. Using the page mode and the NWAIT signal may lead to unpredictable behavior.

28.15.4 Sequential and Non-sequential Accesses

If the chip select and the MSB of addresses as defined in [Table 28-7 on page 514](#) are identical, then the current access lies in the same page as the previous one, and no page break occurs.

Using this information, all data within the same page, sequential or not sequential, are accessed with a minimum access time (t_{sa}). [Figure 28-36 on page 516](#) illustrates access to an 8-bit memory device in page mode, with 8-byte pages. Access to D1 causes a page access with a long access time (t_{pa}). Accesses to D3 and D7, though they are not sequential accesses, only require a short access time (t_{sa}).

If the MSB of addresses are different, the SMC performs the access of a new page. In the same way, if the chip select is different from the previous access, a page break occurs. If two sequential accesses are made to the page mode memory, but separated by an other internal or external peripheral access, a page break occurs on the second access because the chip select of the device was deasserted between both accesses.

Figure 28-36. Access to Non-sequential Data within the Same Page

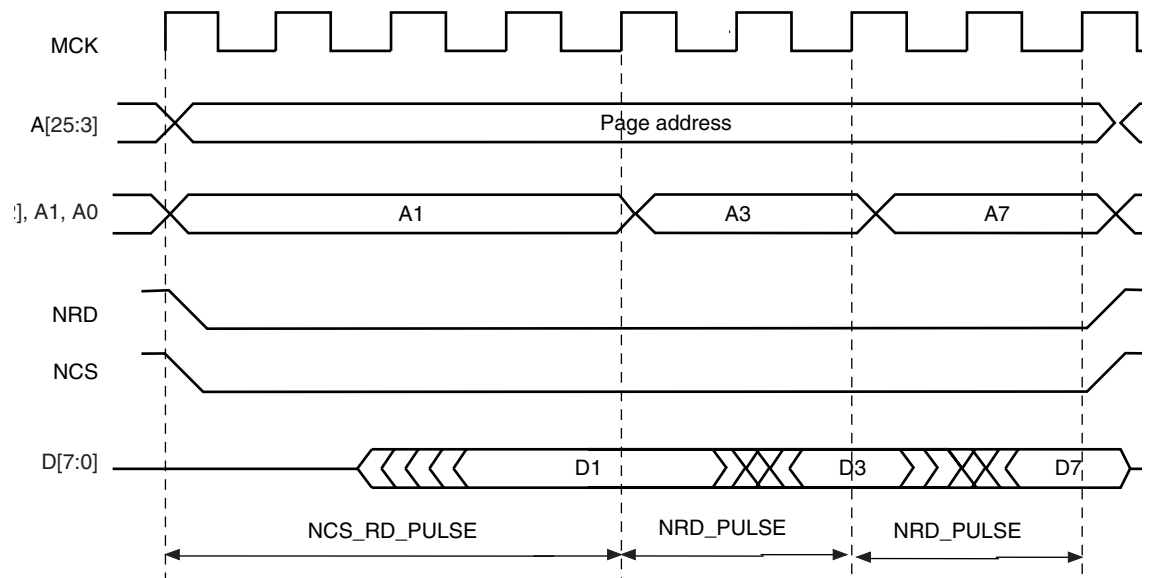

28.16 Static Memory Controller (SMC) User Interface

The SMC is programmed using the registers listed in [Table 28-9 on page 517](#). For each chip select, a set of 4 registers is used to program the parameters of the external device connected on it. In [Table 28-9 on page 517](#), “CS_number” denotes the chip select number. 16 bytes (0x10) are required per chip select.

The user must complete writing the configuration by writing any one of the MODE registers.

Table 28-9. SMC Register Mapping

Offset	Register	Name	Access	Reset State
0x10 x CS_number + 0x00	SMC Setup Register	SETUP	Read/Write	0x00010001
0x10 x CS_number + 0x04	SMC Pulse Register	PULSE	Read/Write	0x04030402
0x10 x CS_number + 0x08	SMC Cycle Register	CYCLE	Read/Write	0x00050005
0x10 x CS_number + 0x0C	SMC Mode Register	MODE	Read/Write	0x10002103

28.16.1 SMC Setup Register

Register Name: SETUP[0 ..NB_CS-1]

Access Type: Read/Write

31	30	29	28	27	26	25	24
-	-	NCS_RD_SETUP					
23	22	21	20	19	18	17	16
-	-	NRD_SETUP					
15	14	13	12	11	10	9	8
-	-	NCS_WR_SETUP					
7	6	5	4	3	2	1	0
-	-	NWE_SETUP					

- **NWE_SETUP: NWE Setup Length**

The NWE signal setup length is defined as:

$$\text{NWE setup length} = (128 * \text{NWE_SETUP}[5] + \text{NWE_SETUP}[4:0]) \text{ clock cycles}$$

- **NCS_WR_SETUP: NCS Setup Length in WRITE Access**

In write access, the NCS signal setup length is defined as:

$$\text{NCS setup length} = (128 * \text{NCS_WR_SETUP}[5] + \text{NCS_WR_SETUP}[4:0]) \text{ clock cycles}$$

- **NRD_SETUP: NRD Setup Length**

The NRD signal setup length is defined in clock cycles as:

$$\text{NRD setup length} = (128 * \text{NRD_SETUP}[5] + \text{NRD_SETUP}[4:0]) \text{ clock cycles}$$

- **NCS_RD_SETUP: NCS Setup Length in READ Access**

In read access, the NCS signal setup length is defined as:

$$\text{NCS setup length} = (128 * \text{NCS_RD_SETUP}[5] + \text{NCS_RD_SETUP}[4:0]) \text{ clock cycles}$$

28.16.2 SMC Pulse Register

Register Name: PULSE[0..NB_CS-1]

Access Type: Read/Write

31	30	29	28	27	26	25	24
-	NCS_RD_PULSE						
23	22	21	20	19	18	17	16
-	NRD_PULSE						
15	14	13	12	11	10	9	8
-	NCS_WR_PULSE						
7	6	5	4	3	2	1	0
-	NWE_PULSE						

- **NWE_PULSE: NWE Pulse Length**

The NWE signal pulse length is defined as:

$$\text{NWE pulse length} = (256 * \text{NWE_PULSE}[6] + \text{NWE_PULSE}[5:0]) \text{ clock cycles}$$

The NWE pulse length must be at least 1 clock cycle.

- **NCS_WR_PULSE: NCS Pulse Length in WRITE Access**

In write access, the NCS signal pulse length is defined as:

$$\text{NCS pulse length} = (256 * \text{NCS_WR_PULSE}[6] + \text{NCS_WR_PULSE}[5:0]) \text{ clock cycles}$$

The NCS pulse length must be at least 1 clock cycle.

- **NRD_PULSE: NRD Pulse Length**

In standard read access, the NRD signal pulse length is defined in clock cycles as:

$$\text{NRD pulse length} = (256 * \text{NRD_PULSE}[6] + \text{NRD_PULSE}[5:0]) \text{ clock cycles}$$

The NRD pulse length must be at least 1 clock cycle.

In page mode read access, the NRD_PULSE parameter defines the duration of the subsequent accesses in the page.

- **NCS_RD_PULSE: NCS Pulse Length in READ Access**

In standard read access, the NCS signal pulse length is defined as:

$$\text{NCS pulse length} = (256 * \text{NCS_RD_PULSE}[6] + \text{NCS_RD_PULSE}[5:0]) \text{ clock cycles}$$

The NCS pulse length must be at least 1 clock cycle.

In page mode read access, the NCS_RD_PULSE parameter defines the duration of the first access to one page.

28.16.3 SMC Cycle Register

Register Name: CYCLE[0..**NB_CS-1**]

Access Type: Read/Write

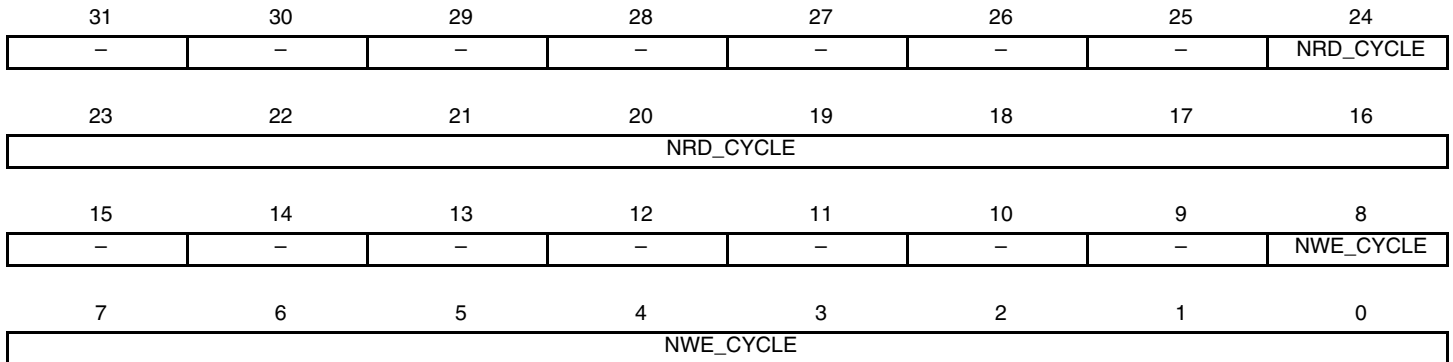

- **NWE_CYCLE: Total Write Cycle Length**

The total write cycle length is the total duration in clock cycles of the write cycle. It is equal to the sum of the setup, pulse and hold steps of the NWE and NCS signals. It is defined as:

$$\text{Write cycle length} = (\text{NWE_CYCLE}[8:7] * 256 + \text{NWE_CYCLE}[6:0]) \text{ clock cycles}$$

- **NRD_CYCLE: Total Read Cycle Length**

The total read cycle length is the total duration in clock cycles of the read cycle. It is equal to the sum of the setup, pulse and hold steps of the NRD and NCS signals. It is defined as:

$$\text{Read cycle length} = (\text{NRD_CYCLE}[8:7] * 256 + \text{NRD_CYCLE}[6:0]) \text{ clock cycles}$$

28.16.4 SMC MODE Register

Register Name: MODE[0..NB_CS-1]

Access Type: Read/Write

31	30	29	28	27	26	25	24
-	-	PS		-	-	-	PMEN
23	22	21	20	19	18	17	16
-	-	-	TDF_MODE	TDF_CYCLES			
15	14	13	12	11	10	9	8
-	-	DBW		-	-	-	BAT
7	6	5	4	3	2	1	0
-	-	EXNW_MODE		-	-	WRITE_MODE	READ_MODE

• READ_MODE:

1: The read operation is controlled by the NRD signal.

- If TDF cycles are programmed, the external bus is marked busy after the rising edge of NRD.
- If TDF optimization is enabled (TDF_MODE =1), TDF wait states are inserted after the setup of NRD.

0: The read operation is controlled by the NCS signal.

- If TDF cycles are programmed, the external bus is marked busy after the rising edge of NCS.
- If TDF optimization is enabled (TDF_MODE =1), TDF wait states are inserted after the setup of NCS.

• WRITE_MODE

1: The write operation is controlled by the NWE signal.

- If TDF optimization is enabled (TDF_MODE =1), TDF wait states will be inserted after the setup of NWE.

0: The write operation is controlled by the NCS signal.

- If TDF optimization is enabled (TDF_MODE =1), TDF wait states will be inserted after the setup of NCS.

• EXNW_MODE: NWAIT Mode

The NWAIT signal is used to extend the current read or write signal. It is only taken into account during the pulse phase of the read and write controlling signal. When the use of NWAIT is enabled, at least one cycle hold duration must be programmed for the read and write controlling signal.

EXNW_MODE		NWAIT Mode
0	0	Disabled
0	1	Reserved
1	0	Frozen Mode
1	1	Ready Mode

- Disabled Mode: The NWAIT input signal is ignored on the corresponding Chip Select.
- Frozen Mode: If asserted, the NWAIT signal freezes the current read or write cycle. After deassertion, the read/write cycle is resumed from the point where it was stopped.

- **Ready Mode:** The NWAIT signal indicates the availability of the external device at the end of the pulse of the controlling read or write signal, to complete the access. If high, the access normally completes. If low, the access is extended until NWAIT returns high.

- **BAT: Byte Access Type**

This field is used only if DBW defines a 16- or 32-bit data bus.

- 1: Byte write access type:
 - Write operation is controlled using NCS, NWR0, NWR1, NWR2, NWR3.
 - Read operation is controlled using NCS and NRD.
- 0: Byte select access type:
 - Write operation is controlled using NCS, NWE, NBS0, NBS1, NBS2 and NBS3
 - Read operation is controlled using NCS, NRD, NBS0, NBS1, NBS2 and NBS3

- **DBW: Data Bus Width**

DBW		Data Bus Width
0	0	8-bit bus
0	1	16-bit bus
1	0	32-bit bus
1	1	Reserved

- **TDF_CYCLES: Data Float Time**

This field gives the integer number of clock cycles required by the external device to release the data after the rising edge of the read controlling signal. The SMC always provide one full cycle of bus turnaround after the TDF_CYCLES period. The external bus cannot be used by another chip select during TDF_CYCLES + 1 cycles. From 0 up to 15 TDF_CYCLES can be set.

- **TDF_MODE: TDF Optimization**

1: TDF optimization is enabled.

- The number of TDF wait states is optimized using the setup period of the next read/write access.

0: TDF optimization is disabled.

- The number of TDF wait states is inserted before the next access begins.

- **PMEN: Page Mode Enabled**

1: Asynchronous burst read in page mode is applied on the corresponding chip select.

0: Standard read is applied.

- **PS: Page Size**

If page mode is enabled, this field indicates the size of the page in bytes.

PS		Page Size
0	0	4-byte page
0	1	8-byte page
1	0	16-byte page
1	1	32-byte page

29. SDRAM Controller (SDRAMC)

Rev: 2.0.0.0

29.1 Features

- **Numerous Configurations Supported**
 - 2K, 4K, 8K Row Address Memory Parts
 - SDRAM with Two or Four Internal Banks
 - SDRAM with 16- or 32-bit Data Path
- **Programming Facilities**
 - Word, Half-word, Byte Access
 - Automatic Page Break When Memory Boundary Has Been Reached
 - Multibank Ping-pong Access
 - Timing Parameters Specified by Software
 - Automatic Refresh Operation, Refresh Rate is Programmable
 - Automatic Update of DS, TCR and PASR Parameters (Mobile SDRAM Devices)
- **Energy-saving Capabilities**
 - Self-refresh, Power-down and Deep Power Modes Supported
 - Supports Mobile SDRAM Devices
- **Error Detection**
 - Refresh Error Interrupt
- **SDRAM Power-up Initialization by Software**
- **CAS Latency of 1, 2, 3 Supported**
- **Auto Precharge Command Not Used**

29.2 Description

The SDRAM Controller (SDRAMC) extends the memory capabilities of a chip by providing the interface to an external 16-bit or 32-bit SDRAM device. The page size supports ranges from 2048 to 8192 and the number of columns from 256 to 2048. It supports byte (8-bit), half-word (16-bit) and word (32-bit) accesses.

The SDRAM Controller supports a read or write burst length of one location. It keeps track of the active row in each bank, thus maximizing SDRAM performance, e.g., the application may be placed in one bank and data in the other banks. So as to optimize performance, it is advisable to avoid accessing different rows in the same bank.

The SDRAM controller supports a CAS latency of 1, 2 or 3 and optimizes the read access depending on the frequency.

The different modes available - self-refresh, power-down and deep power-down modes - minimize power consumption on the SDRAM device.

29.3 Block Diagram

Figure 29-1. SDRAM Controller Block Diagram

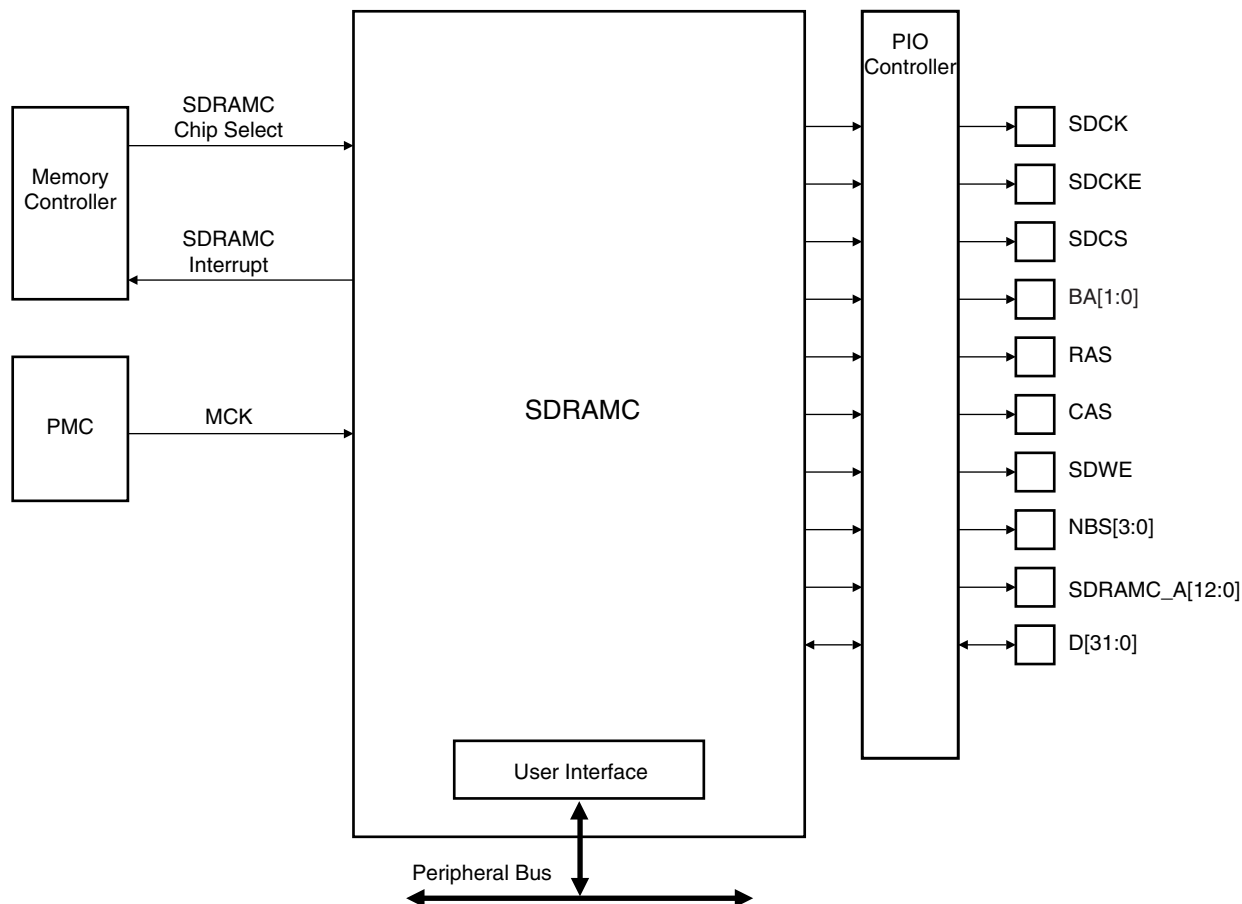

29.4 I/O Lines Description

Table 29-1. I/O Line Description

Name	Description	Type	Active Level
SDCK	SDRAM Clock	Output	
SDCKE	SDRAM Clock Enable	Output	High
SDCS	SDRAM Controller Chip Select	Output	Low
BA[1:0]	Bank Select Signals	Output	
RAS	Row Signal	Output	Low
CAS	Column Signal	Output	Low
SDWE	SDRAM Write Enable	Output	Low
NBS[3:0]	Data Mask Enable Signals	Output	Low
SDRAMC_A[12:0]	Address Bus	Output	
D[31:0]	Data Bus	I/O	

29.5 Application Example

29.5.1 Hardware Interface

Figure 29-2 shows an example of SDRAM device connection to the SDRAM Controller using a 32-bit data bus width. Figure 29-3 shows an example of SDRAM device connection using a 16-bit data bus width. It is important to note that these examples are given for a direct connection of the devices to the SDRAM Controller, without External Bus Interface or PIO Controller multiplexing.

Figure 29-2. SDRAM Controller Connections to SDRAM Devices: 32-bit Data Bus Width

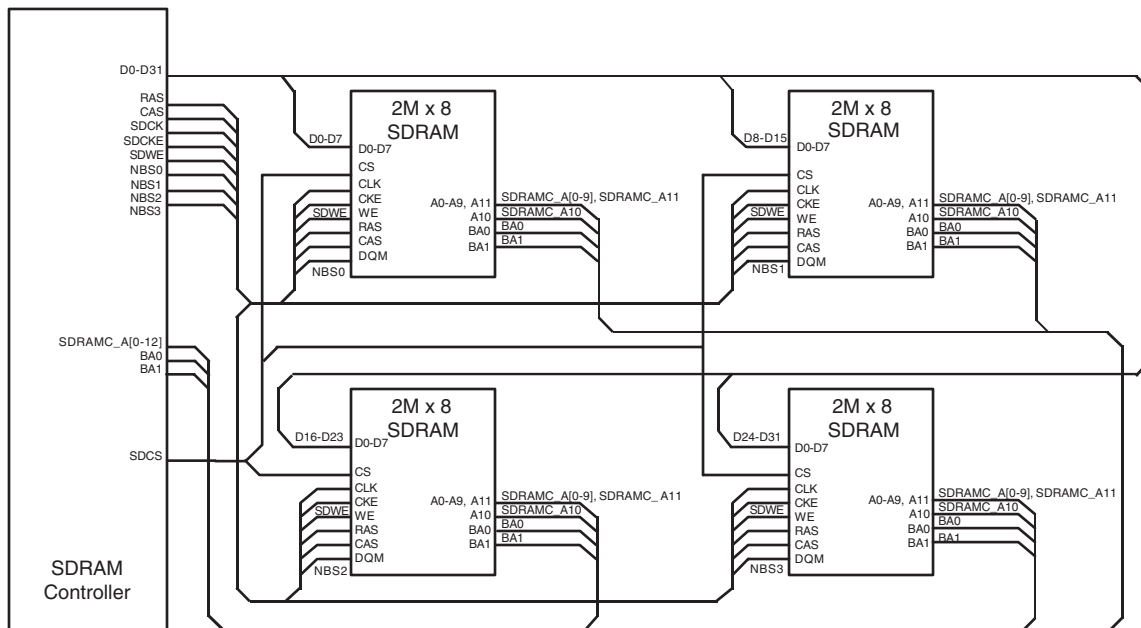
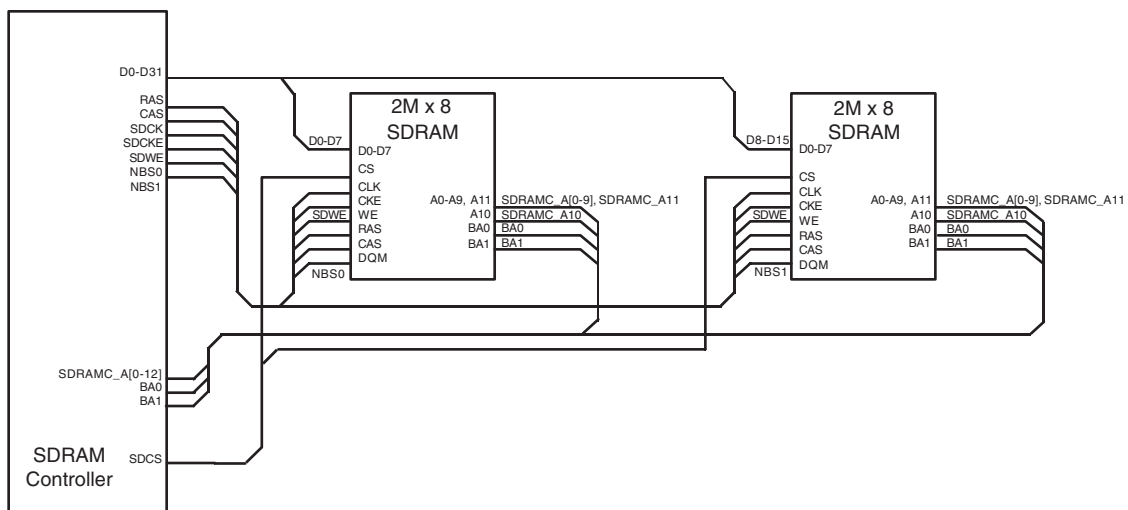

Figure 29-3. SDRAM Controller Connections to SDRAM Devices: 16-bit Data Bus Width



29.5.2 Software Interface

The SDRAM address space is organized into banks, rows, and columns. The SDRAM controller allows mapping different memory types according to the values set in the SDRAMC configuration register.

The SDRAM Controller's function is to make the SDRAM device access protocol transparent to the user. Table 29-2 to Table 29-7 illustrate the SDRAM device memory mapping seen by the user in correlation with the device structure. Various configurations are illustrated.

29.5.2.1 32-bit Memory Data Bus Width

Table 29-2. SDRAM Configuration Mapping: 2K Rows, 256/512/1024/2048 Columns

CPU Address Line																												
2	2	2	2	2	2	2	2	1	1	1	1	1	1	1	1	1	1	0	9	8	7	6	5	4	3	2	1	0
				Bk[1:0]				Row[10:0]										Column[7:0]							M[1:0]			
				Bk[1:0]				Row[10:0]										Column[8:0]							M[1:0]			
				Bk[1:0]				Row[10:0]										Column[9:0]							M[1:0]			
Bk[1:0]				Row[10:0]										Column[10:0]							M[1:0]							

Table 29-3. SDRAM Configuration Mapping: 4K Rows, 256/512/1024/2048 Columns

CPU Address Line																												
2	2	2	2	2	2	2	2	1	1	1	1	1	1	1	1	1	1	0	9	8	7	6	5	4	3	2	1	0
				Bk[1:0]				Row[11:0]										Column[7:0]							M[1:0]			
				Bk[1:0]				Row[11:0]										Column[8:0]							M[1:0]			
				Bk[1:0]				Row[11:0]										Column[9:0]							M[1:0]			
Bk[1:0]				Row[11:0]										Column[10:0]							M[1:0]							

Table 29-4. SDRAM Configuration Mapping: 8K Rows, 256/512/1024/2048 Columns

CPU Address Line																												
2	2	2	2	2	2	2	2	1	1	1	1	1	1	1	1	1	1	0	9	8	7	6	5	4	3	2	1	0
				Bk[1:0]				Row[12:0]										Column[7:0]							M[1:0]			
				Bk[1:0]				Row[12:0]										Column[8:0]							M[1:0]			
				Bk[1:0]				Row[12:0]										Column[9:0]							M[1:0]			
Bk[1:0]				Row[12:0]										Column[10:0]							M[1:0]							

- Notes: 1. M[1:0] is the byte address inside a 32-bit word.
 2. Bk[1] = BA1, Bk[0] = BA0.

29.5.2.2 16-bit Memory Data Bus Width

Table 29-5. SDRAM Configuration Mapping: 2K Rows, 256/512/1024/2048 Columns

CPU Address Line																											
27	26	25	24	23	22	21	20	19	18	17	16	15	14	13	12	11	10	9	8	7	6	5	4	3	2	1	0
						Bk[1:0]		Row[10:0]										Column[7:0]							M	0	
						Bk[1:0]		Row[10:0]										Column[8:0]							M	0	
					Bk[1:0]		Row[10:0]										Column[9:0]							M	0		
			Bk[1:0]		Row[10:0]										Column[10:0]							M	0				

Table 29-6. SDRAM Configuration Mapping: 4K Rows, 256/512/1024/2048 Columns

CPU Address Line																											
27	26	25	24	23	22	21	20	19	18	17	16	15	14	13	12	11	10	9	8	7	6	5	4	3	2	1	0
						Bk[1:0]		Row[11:0]										Column[7:0]							M	0	
				Bk[1:0]		Row[11:0]										Column[8:0]							M	0			
			Bk[1:0]		Row[11:0]										Column[9:0]							M	0				
		Bk[1:0]		Row[11:0]										Column[10:0]							M	0					

Table 29-7. SDRAM Configuration Mapping: 8K Rows, 256/512/1024/2048 Columns

CPU Address Line																											
27	26	25	24	23	22	21	20	19	18	17	16	15	14	13	12	11	10	9	8	7	6	5	4	3	2	1	0
						Bk[1:0]		Row[12:0]										Column[7:0]							M	0	
			Bk[1:0]		Row[12:0]										Column[8:0]							M	0				
		Bk[1:0]		Row[12:0]										Column[9:0]							M	0					
	Bk[1:0]		Row[12:0]										Column[10:0]							M	0						

- Notes:
1. M0 is the byte address inside a 16-bit half-word.
 2. Bk[1] = BA1, Bk[0] = BA0.

29.6 Product Dependencies

29.6.1 SDRAM Device Initialization

The initialization sequence is generated by software. The SDRAM devices are initialized by the following sequence:

1. SDRAM features must be set in the configuration register: asynchronous timings (TRC, TRAS, ...), number of column, rows, CAS latency, and the data bus width.
2. For mobile SDRAM, temperature-compensated self refresh (TCSR), drive strength (DS) and partial array self refresh (PASR) must be set in the Low Power Register.
3. The SDRAM memory type must be set in the Memory Device Register.
4. A minimum pause of 200 μ s is provided to precede any signal toggle.
5. An All Banks Precharge command must be issued to the SDRAM devices. The application must set Mode to 2 in the Mode Register and perform a write access to any SDRAM address.
6. Eight auto-refresh (CBR) cycles are provided. The application must set the Mode to 4 in the Mode Register and performs a write access to any SDRAM location eight times.
7. A Mode Register set (MRS) cycle must be issued to program the parameters of the SDRAM devices, in particular CAS latency and burst length. The application must set Mode to 3 in the Mode Register and perform a write access to the SDRAM. The write address must be chosen so that BA[1:0] are set to 0. For example, with a 16-bit 128 MB SDRAM (12 rows, 9 columns, 4 banks) bank address, the SDRAM write access should be done at the address 0x20000000.
8. For mobile SDRAM initialization, an Extended Mode Register set (EMRS) cycle must be issued to program the SDRAM parameters (TCSR, PASR, DS). The application must set Mode to 5 in the Mode Register and perform a write access to the SDRAM. The write address must be chosen so that BA[1] or BA[0] are set to 1. For example, with a 16-bit 128 MB SDRAM, (12 rows, 9 columns, 4 banks) bank address the SDRAM write access should be done at the address 0x20800000 or 0x20400000.
9. The application must go into Normal Mode, setting Mode to 0 in the Mode Register and performing a write access at any location in the SDRAM.
10. Write the refresh rate into the count field in the SDRAMC Refresh Timer register. (Refresh rate = delay between refresh cycles). The SDRAM device requires a refresh every 15.625 μ s or 7.81 μ s. With a 100 MHz frequency, the Refresh Timer Counter Register must be set with the value 1562 (15.625 μ s x 100 MHz) or 781 (7.81 μ s x 100 MHz).

After initialization, the SDRAM devices are fully functional.

Figure 29-4. SDRAM Device Initialization Sequence

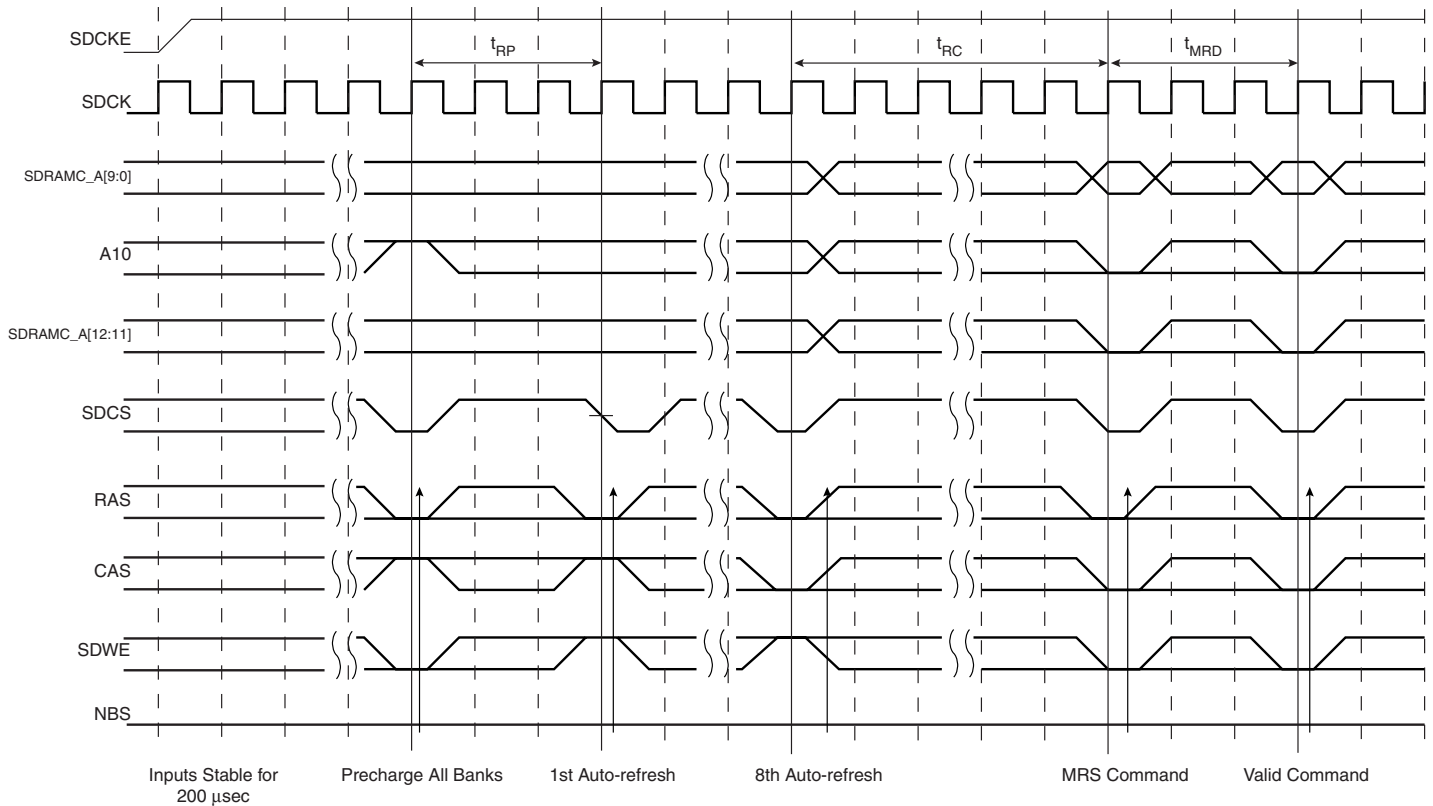

29.6.2 I/O Lines

The pins used for interfacing the SDRAM Controller may be multiplexed with the PIO lines. The programmer must first program the PIO controller to assign the SDRAM Controller pins to their peripheral function. If I/O lines of the SDRAM Controller are not used by the application, they can be used for other purposes by the PIO Controller.

29.6.3 Interrupt

The SDRAM Controller has an interrupt line connected to the interrupt controller. In order to handle interrupts, the interrupt controller must be programmed before configuring the SDRAM Controller.

Using the SDRAM Controller interrupt requires the IC to be programmed first.)

29.7 Functional Description

29.7.1 SDRAM Controller Write Cycle

The SDRAM Controller allows burst access or single access. In both cases, the SDRAM controller keeps track of the active row in each bank, thus maximizing performance. To initiate a burst access, the SDRAM Controller uses the transfer type signal provided by the master requesting the access. If the next access is a sequential write access, writing to the SDRAM device is carried out. If the next access is a write-sequential access, but the current access is to a boundary page, or if the next access is in another row, then the SDRAM Controller generates a precharge command, activates the new row and initiates a write command. To comply with SDRAM timing parameters, additional clock cycles are inserted between precharge/active (t_{RP}) commands and active/write (t_{RCD}) commands. For definition of these timing parameters, refer to the "SDRAMC Configuration Register" on page 540. This is described in Figure 29-5 below.

Figure 29-5. Write Burst, 32-bit SDRAM Access

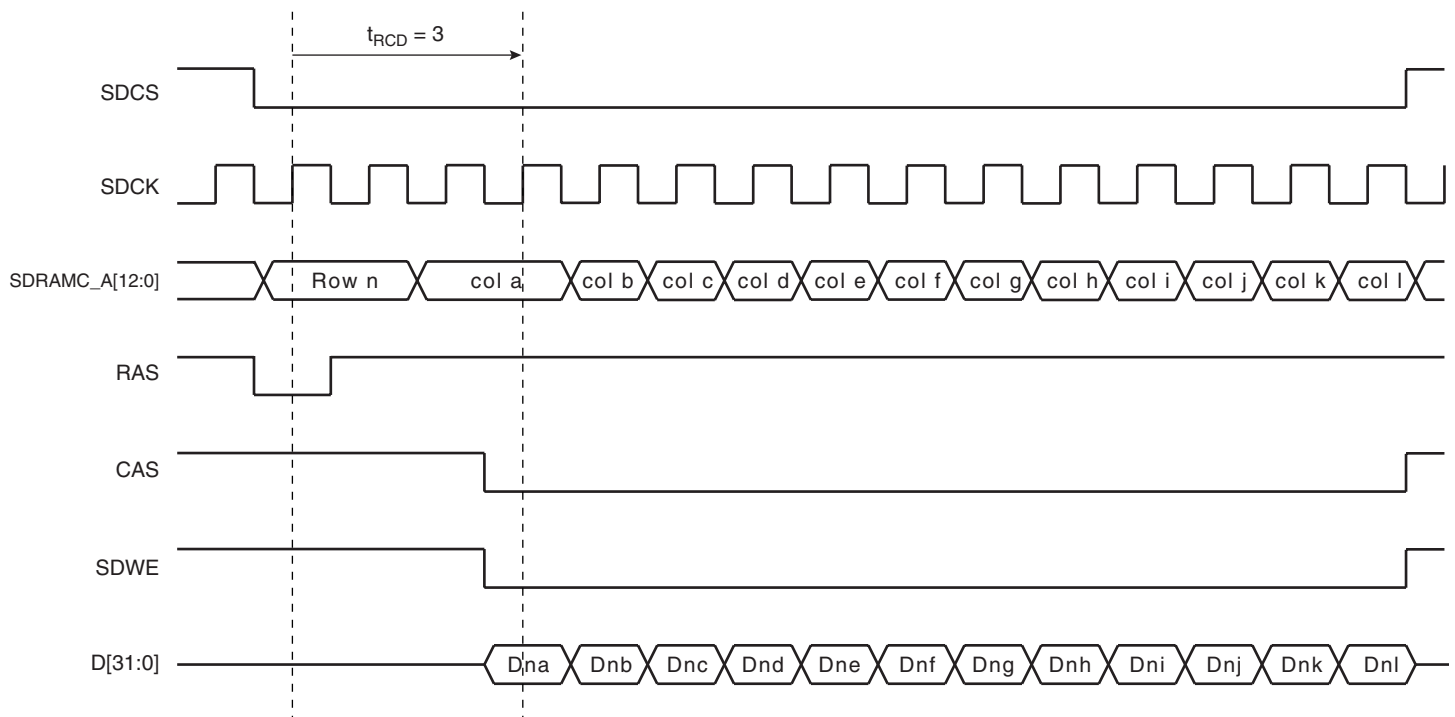

29.7.2 SDRAM Controller Read Cycle

The SDRAM Controller allows burst access, incremental burst of unspecified length or single access. In all cases, the SDRAM Controller keeps track of the active row in each bank, thus maximizing performance of the SDRAM. If row and bank addresses do not match the previous row/bank address, then the SDRAM controller automatically generates a precharge command, activates the new row and starts the read command. To comply with the SDRAM timing parameters, additional clock cycles on SDCK are inserted between precharge and active commands (t_{RP}) and between active and read command (t_{RCD}). These two parameters are set in the configuration register of the SDRAM Controller. After a read command, additional wait states are generated to comply with the CAS latency (1, 2 or 3 clock delays specified in the configuration register).

For a single access or an incremented burst of unspecified length, the SDRAM Controller anticipates the next access. While the last value of the column is returned by the SDRAM Controller on the bus, the SDRAM Controller anticipates the read to the next column and thus anticipates the CAS latency. This reduces the effect of the CAS latency on the internal bus.

For burst access of specified length (4, 8, 16 words), access is not anticipated. This case leads to the best performance. If the burst is broken (border, busy mode, etc.), the next access is handled as an incrementing burst of unspecified length.

Figure 29-6. Read Burst, 32-bit SDRAM Access

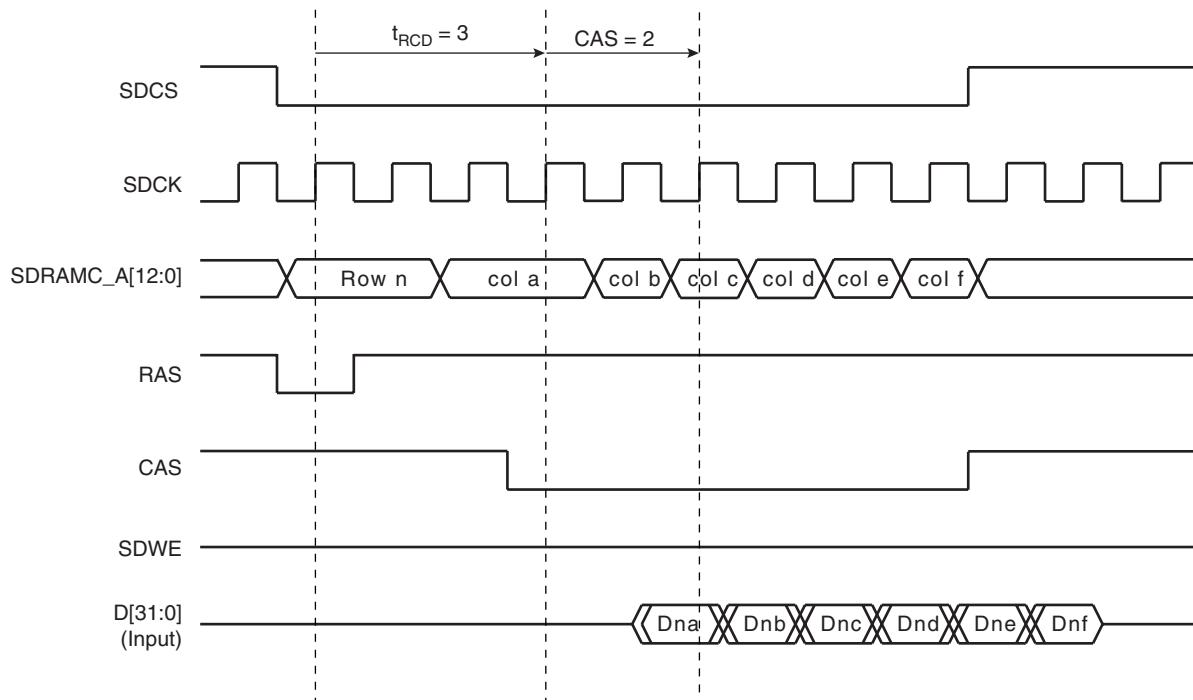

29.7.3 Border Management

When the memory row boundary has been reached, an automatic page break is inserted. In this case, the SDRAM controller generates a precharge command, activates the new row and initiates a read or write command. To comply with SDRAM timing parameters, an additional clock cycle is inserted between the precharge/active (t_{RP}) command and the active/read (t_{RCD}) command. This is described in Figure 29-7 below.

Figure 29-7. Read Burst with Boundary Row Access

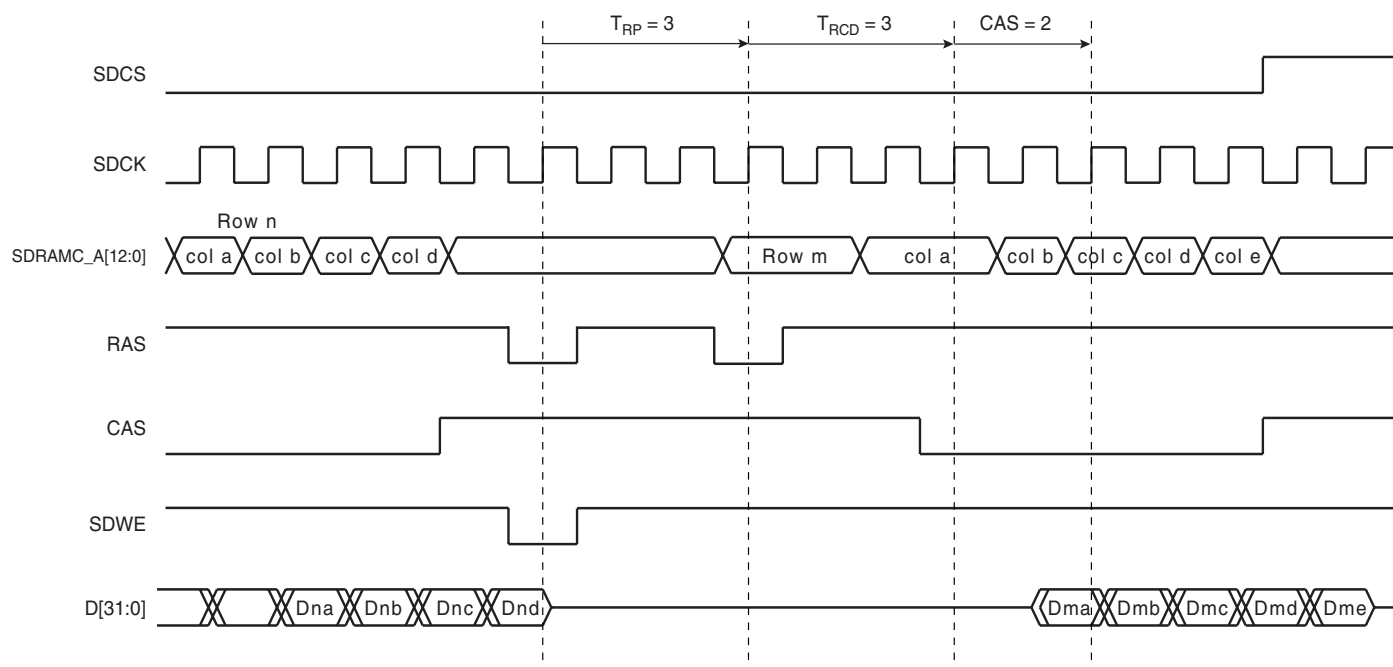

29.7.4 SDRAM Controller Refresh Cycles

An auto-refresh command is used to refresh the SDRAM device. Refresh addresses are generated internally by the SDRAM device and incremented after each auto-refresh automatically. The SDRAM Controller generates these auto-refresh commands periodically. An internal timer is loaded with the value in the register TR that indicates the number of clock cycles between refresh cycles.

A refresh error interrupt is generated when the previous auto-refresh command did not perform. It is acknowledged by reading the Interrupt Status Register (ISR).

When the SDRAM Controller initiates a refresh of the SDRAM device, internal memory accesses are not delayed. However, if the CPU tries to access the SDRAM, the slave indicates that the device is busy and the master is held by a wait signal. See [Figure 29-8](#).

Figure 29-8. Refresh Cycle Followed by a Read Access

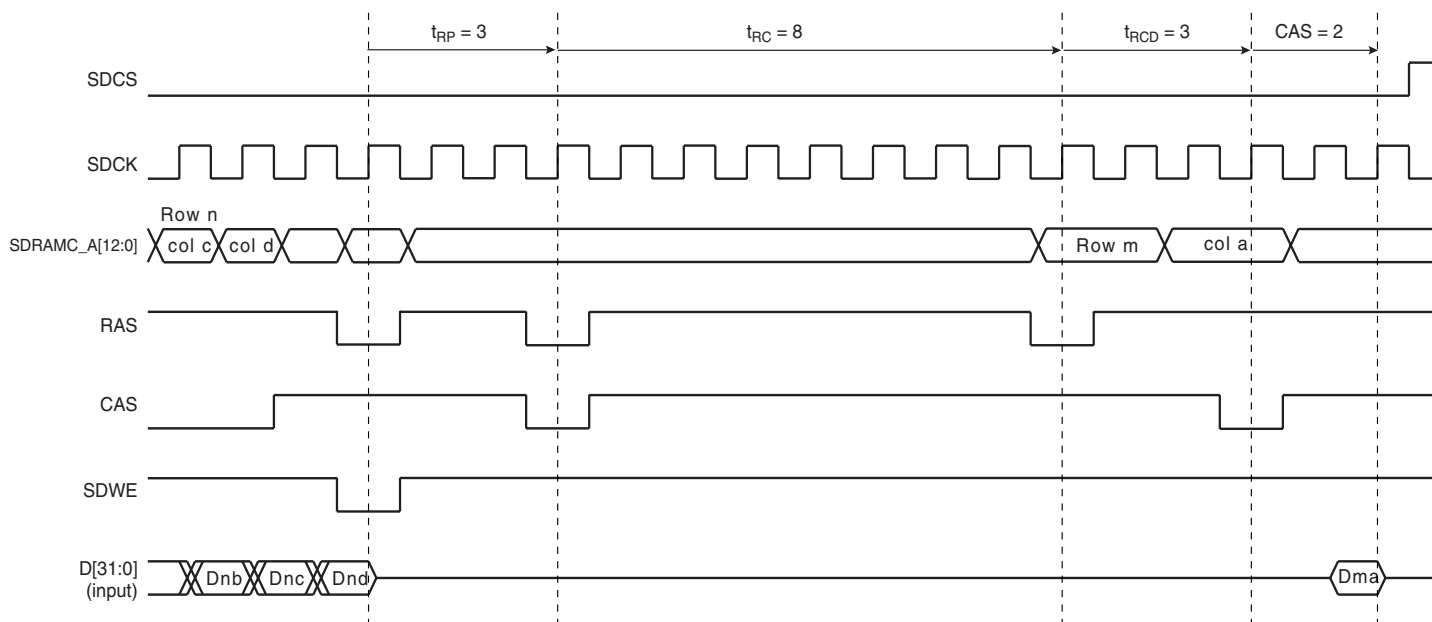

29.7.5 Power Management

Three low-power modes are available:

- **Self-refresh Mode:** The SDRAM executes its own Auto-refresh cycle without control of the SDRAM Controller. Current drained by the SDRAM is very low.
- **Power-down Mode:** Auto-refresh cycles are controlled by the SDRAM Controller. Between auto-refresh cycles, the SDRAM is in power-down. Current drained in Power-down mode is higher than in Self-refresh Mode.
- **Deep Power-down Mode:** (Only available with Mobile SDRAM) The SDRAM contents are lost, but the SDRAM does not drain any current.

The SDRAM Controller activates one low-power mode as soon as the SDRAM device is not selected. It is possible to delay the entry in self-refresh and power-down mode after the last access by programming a timeout value in the Low Power Register.

29.7.5.1 Self-refresh Mode

This mode is selected by programming the LPCB field to 1 in the SDRAMC Low Power Register. In self-refresh mode, the SDRAM device retains data without external clocking and provides its own internal clocking, thus performing its own auto-refresh cycles. All the inputs to the SDRAM device become “don’t care” except SDCKE, which remains low. As soon as the SDRAM device is selected, the SDRAM Controller provides a sequence of commands and exits self-refresh mode.

Some low-power SDRAMs (e.g., mobile SDRAM) can refresh only one quarter or a half quarter or all banks of the SDRAM array. This feature reduces the self-refresh current. To configure this feature, Temperature Compensated Self Refresh (TCSR), Partial Array Self Refresh (PASR) and Drive Strength (DS) parameters must be set in the Low Power Register and transmitted to the low-power SDRAM during initialization.

After initialization, as soon as PASR/DS/TCSR fields are modified and self-refresh mode is activated, the Extended Mode Register is accessed automatically and PASR/DS/TCSR bits are updated before entry into self-refresh mode.

The SDRAM device must remain in self-refresh mode for a minimum period of t_{RAS} and may remain in self-refresh mode for an indefinite period. This is described in [Figure 29-9](#).

Figure 29-9. Self-refresh Mode Behavior

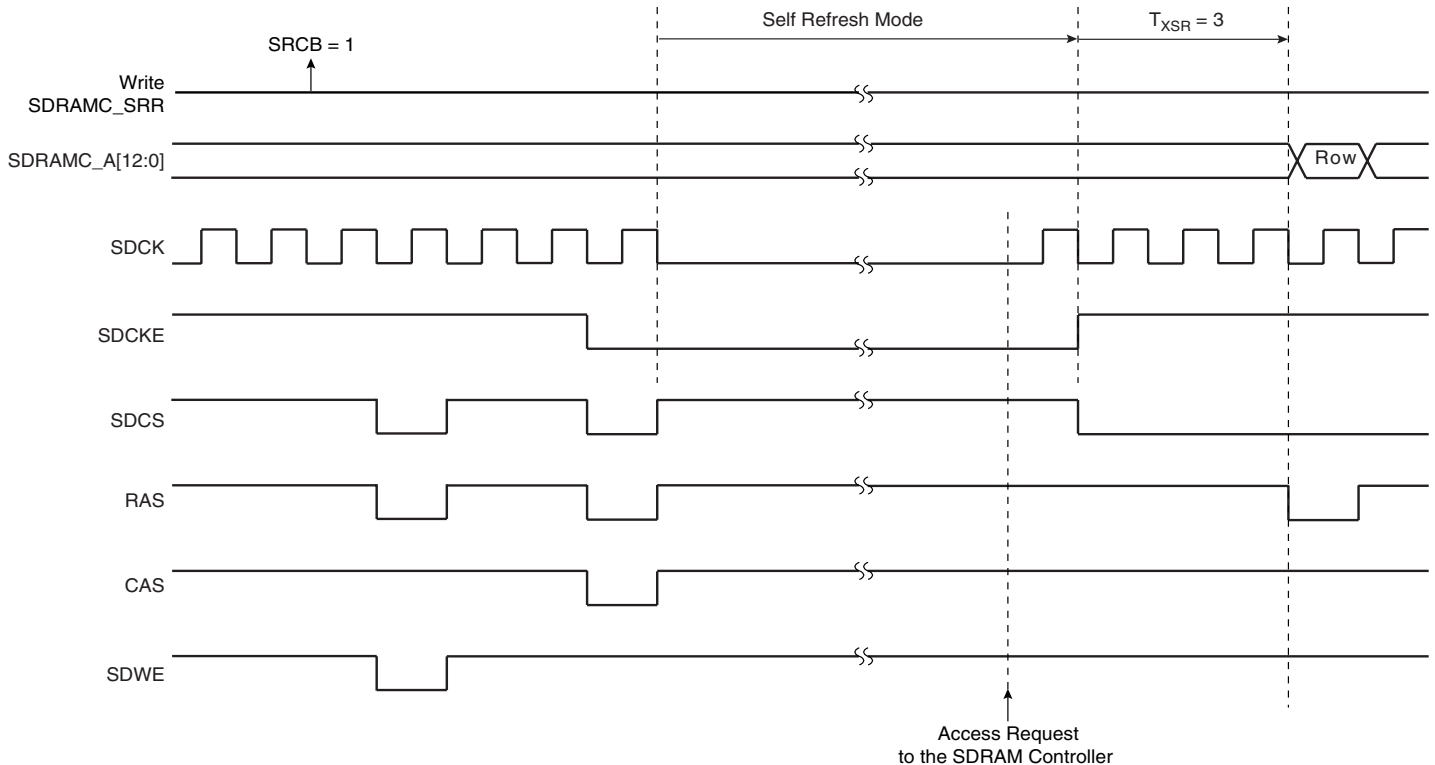

29.7.5.2 Low-power Mode

This mode is selected by programming the LPCB field to 2 in the SDRAMC Low Power Register. Power consumption is greater than in self-refresh mode. All the input and output buffers of the SDRAM device are deactivated except SDCKE, which remains low. In contrast to self-refresh mode, the SDRAM device cannot remain in low-power mode longer than the refresh period (64 ms for a whole device refresh operation). As no auto-refresh operations are performed by the SDRAM itself, the SDRAM Controller carries out the refresh operation. The exit procedure is faster than in self-refresh mode.

This is described in [Figure 29-10](#).

Figure 29-10. Low-power Mode Behavior

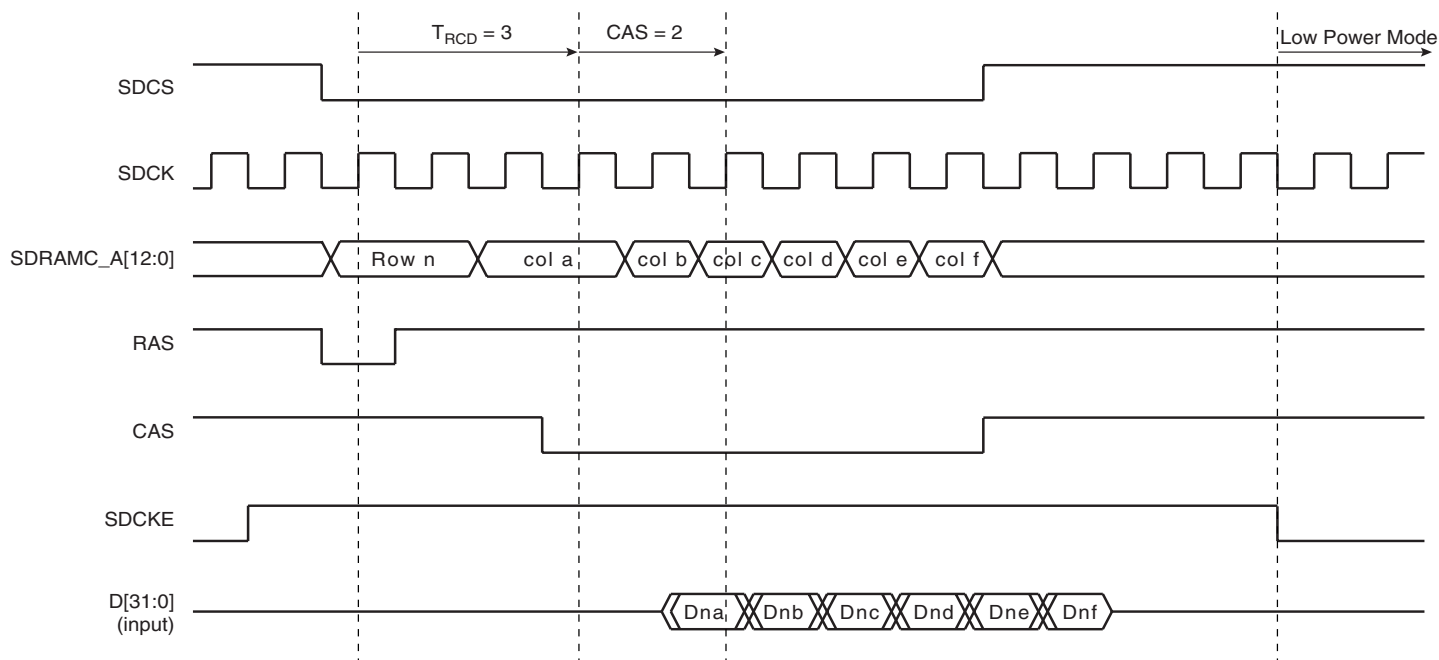

29.7.5.3 Deep Power-down Mode

This mode is selected by programming the LPCB field to 3 in the SDRAMC Low Power Register. When this mode is activated, all internal voltage generators inside the SDRAM are stopped and all data is lost.

When this mode is enabled, the application must not access to the SDRAM until a new initialization sequence is done (See "SDRAM Device Initialization" on page 528).

This is described in [Figure 29-11](#).

Figure 29-11. Deep Power-down Mode Behavior

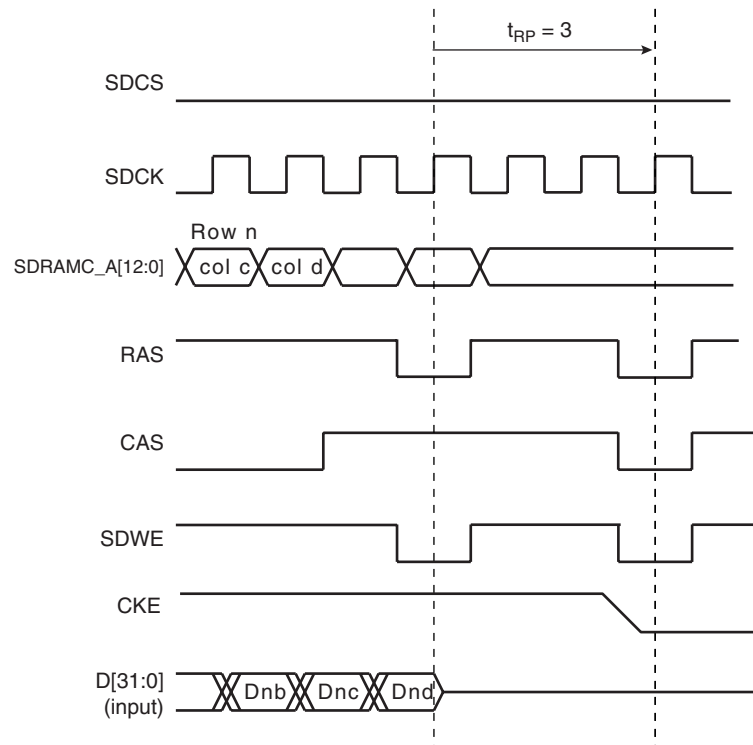

29.8 SDRAM Controller User Interface

Table 29-8. SDRAM Controller Memory Map

Offset	Register	Name	Access	Reset State
0x00	SDRAMC Mode Register	MR	Read/Write	0x00000000
0x04	SDRAMC Refresh Timer Register	TR	Read/Write	0x00000000
0x08	SDRAMC Configuration Register	CR	Read/Write	0x852372C0
0x0C	SDRAMC High Speed Register	HSR	Read/Write	0x00
0x10	SDRAMC Low Power Register	LPR	Read/Write	0x0
0x14	SDRAMC Interrupt Enable Register	IER	Write-only	–
0x18	SDRAMC Interrupt Disable Register	IDR	Write-only	–
0x1C	SDRAMC Interrupt Mask Register	IMR	Read-only	0x0
0x20	SDRAMC Interrupt Status Register	ISR	Read-only	0x0
0x24	SDRAMC Memory Device Register	MDR	Read	0x0
0x28 - 0xFC	Reserved	–	–	–

29.8.1 SDRAMC Mode Register

Register Name: MR
Access Type: Read/Write
Reset Value: 0x00000000

31	30	29	28	27	26	25	24
–	–	–	–	–	–	–	–
23	22	21	20	19	18	17	16
–	–	–	–	–	–	–	–
15	14	13	12	11	10	9	8
–	–	–	–	–	–	–	–
7	6	5	4	3	2	1	0
–	–	–	–	–			MODE

- **MODE: SDRAMC Command Mode**

This field defines the command issued by the SDRAM Controller when the SDRAM device is accessed.

Table 29-9.

MODE			Description
0	0	0	Normal mode. Any access to the SDRAM is decoded normally.
0	0	1	The SDRAM Controller issues a NOP command when the SDRAM device is accessed regardless of the cycle.
0	1	0	The SDRAM Controller issues an “All Banks Precharge” command when the SDRAM device is accessed regardless of the cycle.
0	1	1	The SDRAM Controller issues a “Load Mode Register” command when the SDRAM device is accessed regardless of the cycle. The address offset with respect to the SDRAM device base address is used to program the Mode Register. For instance, when this mode is activated, an access to the “SDRAM_Base + offset” address generates a “Load Mode Register” command with the value “offset” written to the SDRAM device Mode Register.
1	0	0	The SDRAM Controller issues an “Auto-Refresh” Command when the SDRAM device is accessed regardless of the cycle. Previously, an “All Banks Precharge” command must be issued.
1	0	1	The SDRAM Controller issues an extended load mode register command when the SDRAM device is accessed regardless of the cycle. The address offset with respect to the SDRAM device base address is used to program the Mode Register. For instance, when this mode is activated, an access to the “SDRAM_Base + offset” address generates an “Extended Load Mode Register” command with the value “offset” written to the SDRAM device Mode Register.
1	1	0	Deep power-down mode. Enters deep power-down mode.

29.8.2 SDRAMC Refresh Timer Register

Register Name: TR
Access Type: Read/Write
Reset Value: 0x00000000

31	30	29	28	27	26	25	24
–	–	–	–	–	–	–	–
23	22	21	20	19	18	17	16
–	–	–	–	–	–	–	–
15	14	13	12	11	10	9	8
–	–	–	–	COUNT			
7	6	5	4	3	2	1	0
COUNT							

- **COUNT: SDRAMC Refresh Timer Count**

This 12-bit field is loaded into a timer that generates the refresh pulse. Each time the refresh pulse is generated, a refresh burst is initiated. The value to be loaded depends on the SDRAMC clock frequency (MCK: Master Clock), the refresh rate of the SDRAM device and the refresh burst length where 15.6 μ s per row is a typical value for a burst of length one.

To refresh the SDRAM device, this 12-bit field must be written. If this condition is not satisfied, no refresh command is issued and no refresh of the SDRAM device is carried out.

29.8.3 SDRAMC Configuration Register

Register Name: CR
Access Type: Read/Write
Reset Value: 0x852372C0

31	30	29	28	27	26	25	24
TXSR				TRAS			
23	22	21	20	19	18	17	16
TRCD				TRP			
15	14	13	12	11	10	9	8
TRC				TWR			
7	6	5	4	3	2	1	0
DBW	CAS		NB	NR		NC	

• **NC: Number of Column Bits**

Reset value is 8 column bits.

NC		Column Bits
0	0	8
0	1	9
1	0	10
1	1	11

• **NR: Number of Row Bits**

Reset value is 11 row bits.

NR		Row Bits
0	0	11
0	1	12
1	0	13
1	1	Reserved

• **NB: Number of Banks**

Reset value is two banks.

NB	Number of Banks
0	2
1	4

- **CAS: CAS Latency**

Reset value is two cycles.

In the SDRAMC, only a CAS latency of one, two and three cycles is managed.

CAS		CAS Latency (Cycles)
0	0	Reserved
0	1	1
1	0	2
1	1	3

- **DBW: Data Bus Width**

Reset value is 16 bits

0: Data bus width is 32 bits.

1: Data bus width is 16 bits.

- **TWR: Write Recovery Delay**

Reset value is two cycles.

This field defines the Write Recovery Time in number of cycles. Number of cycles is between 0 and 15.

- **TRC: Row Cycle Delay**

Reset value is seven cycles.

This field defines the delay between a Refresh and an Activate Command in number of cycles. Number of cycles is between 0 and 15.

- **TRP: Row Precharge Delay**

Reset value is three cycles.

This field defines the delay between a Precharge Command and another Command in number of cycles. Number of cycles is between 0 and 15.

- **TRCD: Row to Column Delay**

Reset value is two cycles.

This field defines the delay between an Activate Command and a Read/Write Command in number of cycles. Number of cycles is between 0 and 15.

- **TRAS: Active to Precharge Delay**

Reset value is five cycles.

This field defines the delay between an Activate Command and a Precharge Command in number of cycles. Number of cycles is between 0 and 15.

- **TXSR: Exit Self Refresh to Active Delay**

Reset value is height cycles.

This field defines the delay between SCKE set high and an Activate Command in number of cycles. Number of cycles is between 0 and 15.

29.8.4 SDRAMC High Speed Register

Register Name: HSR

Access Type: Read/Write

31	30	29	28	27	26	25	24
-	-	-	-	-	-	-	-
23	22	21	20	19	18	17	16
-	-	-	-	-	-	-	-
15	14	13	12	11	10	9	8
-	-	-	-	-	-	-	-
7	6	5	4	3	2	1	0
-	-	-	-	-	-	-	DA

• **DA: Decode Cycle Enable**

A decode cycle can be added on the addresses as soon as a non-sequential access is performed on the HSB bus.

The addition of the decode cycle allows the SDRAMC to gain time to access the SDRAM memory.

0: Decode cycle is disabled.

1: Decode cycle is enabled.

29.8.5 SDRAMC Low Power Register

Register Name: LPR
Access Type: Read/Write
Reset Value: 0x0

31	30	29	28	27	26	25	24
-	-	-	-	-	-	-	-
23	22	21	20	19	18	17	16
-	-	-	-	-	-	-	-
15	14	13	12	11	10	9	8
-	-	TIMEOUT		DS		TCSR	
7	6	5	4	3	2	1	0
-	PASR		-	-	LPCB		

- **LPCB: Low-power Configuration Bits**

00	Low Power Feature is inhibited: no Power-down, Self-refresh or Deep Power-down command is issued to the SDRAM device.
01	The SDRAM Controller issues a Self-refresh command to the SDRAM device, the SDCLK clock is deactivated and the SDCKE signal is set low. The SDRAM device leaves the Self Refresh Mode when accessed and enters it after the access.
10	The SDRAM Controller issues a Power-down Command to the SDRAM device after each access, the SDCKE signal is set to low. The SDRAM device leaves the Power-down Mode when accessed and enters it after the access.
11	The SDRAM Controller issues a Deep Power-down command to the SDRAM device. This mode is unique to low-power SDRAM.

- **PASR: Partial Array Self-refresh (only for low-power SDRAM)**

PASR parameter is transmitted to the SDRAM during initialization to specify whether only one quarter, one half or all banks of the SDRAM array are enabled. Disabled banks are not refreshed in self-refresh mode. This parameter must be set according to the SDRAM device specification.

After initialization, as soon as PASR field is modified and self-refresh mode is activated, the Extended Mode Register is accessed automatically and PASR bits are updated before entry in self-refresh mode.

- **TCSR: Temperature Compensated Self-Refresh (only for low-power SDRAM)**

TCSR parameter is transmitted to the SDRAM during initialization to set the refresh interval during self-refresh mode depending on the temperature of the low-power SDRAM. This parameter must be set according to the SDRAM device specification.

After initialization, as soon as TCSR field is modified and self-refresh mode is activated, the Extended Mode Register is accessed automatically and TCSR bits are updated before entry in self-refresh mode.

- **DS: Drive Strength (only for low-power SDRAM)**

DS parameter is transmitted to the SDRAM during initialization to select the SDRAM strength of data output. This parameter must be set according to the SDRAM device specification.

After initialization, as soon as DS field is modified and self-refresh mode is activated, the Extended Mode Register is accessed automatically and DS bits are updated before entry in self-refresh mode.

- **TIMEOUT: Time to define when low-power mode is enabled**

00	The SDRAM controller activates the SDRAM low-power mode immediately after the end of the last transfer.
01	The SDRAM controller activates the SDRAM low-power mode 64 clock cycles after the end of the last transfer.
10	The SDRAM controller activates the SDRAM low-power mode 128 clock cycles after the end of the last transfer.
11	Reserved.

29.8.6 SDRAMC Interrupt Enable Register

Register Name: IER

Access Type: Write-only

31	30	29	28	27	26	25	24
-	-	-	-	-	-	-	-
23	22	21	20	19	18	17	16
-	-	-	-	-	-	-	-
15	14	13	12	11	10	9	8
-	-	-	-	-	-	-	-
7	6	5	4	3	2	1	0
-	-	-	-	-	-	-	RES

• RES: Refresh Error Status

0: No effect.

1: Enables the refresh error interrupt.

29.8.7 SDRAMC Interrupt Disable Register

Register Name: IDR

Access Type: Write-only

31	30	29	28	27	26	25	24
-	-	-	-	-	-	-	-
23	22	21	20	19	18	17	16
-	-	-	-	-	-	-	-
15	14	13	12	11	10	9	8
-	-	-	-	-	-	-	-
7	6	5	4	3	2	1	0
-	-	-	-	-	-	-	RES

• RES: Refresh Error Status

0: No effect.

1: Disables the refresh error interrupt.

29.8.8 SDRAMC Interrupt Mask Register

Register Name: IMR

Access Type: Read-only

31	30	29	28	27	26	25	24
-	-	-	-	-	-	-	-
23	22	21	20	19	18	17	16
-	-	-	-	-	-	-	-
15	14	13	12	11	10	9	8
-	-	-	-	-	-	-	-
7	6	5	4	3	2	1	0
-	-	-	-	-	-	-	RES

• RES: Refresh Error Status

- 0: The refresh error interrupt is disabled.
- 1: The refresh error interrupt is enabled.

29.8.9 SDRAMC Interrupt Status Register

Register Name: ISR

Access Type: Read-only

31	30	29	28	27	26	25	24
-	-	-	-	-	-	-	-
23	22	21	20	19	18	17	16
-	-	-	-	-	-	-	-
15	14	13	12	11	10	9	8
-	-	-	-	-	-	-	-
7	6	5	4	3	2	1	0
-	-	-	-	-	-	-	RES

• RES: Refresh Error Status

0: No refresh error has been detected since the register was last read.

1: A refresh error has been detected since the register was last read.

29.8.10 SDRAMC Memory Device Register

Register Name: MDR

Access Type: Read/Write

31	30	29	28	27	26	25	24
–	–	–	–	–	–	–	–
23	22	21	20	19	18	17	16
–	–	–	–	–	–	–	–
15	14	13	12	11	10	9	8
–	–	–	–	–	–	–	–
7	6	5	4	3	2	1	0
–	–	–	–	–	–	MD	

• MD: Memory Device Type

00	SDRAM
01	Low-power SDRAM
10	Reserved
11	Reserved.

30. Error Corrected Code (ECC) Controller

Rev: 1.0.0.0

30.1 Features

- **Hardware Error Corrected Code (ECC) Generation**
 - Detection and Correction by Software
- **Supports NAND Flash and SmartMedia™ Devices with 8- or 16-bit Data Path.**
- **Supports NAND Flash/SmartMedia with Page Sizes of 528, 1056, 2112 and 4224 Bytes, Specified by Software**

30.2 Description

NAND Flash/SmartMedia devices contain by default invalid blocks which have one or more invalid bits. Over the NAND Flash/SmartMedia lifetime, additional invalid blocks may occur which can be detected/corrected by ECC code.

The ECC Controller is a mechanism that encodes data in a manner that makes possible the identification and correction of certain errors in data. The ECC controller is capable of single bit error correction and 2-bit random detection. When NAND Flash/SmartMedia have more than 2 bits of errors, the data cannot be corrected.

The ECC user interface is accesible through the peripheral bus.

30.3 Block Diagram

Figure 30-1. Block Diagram

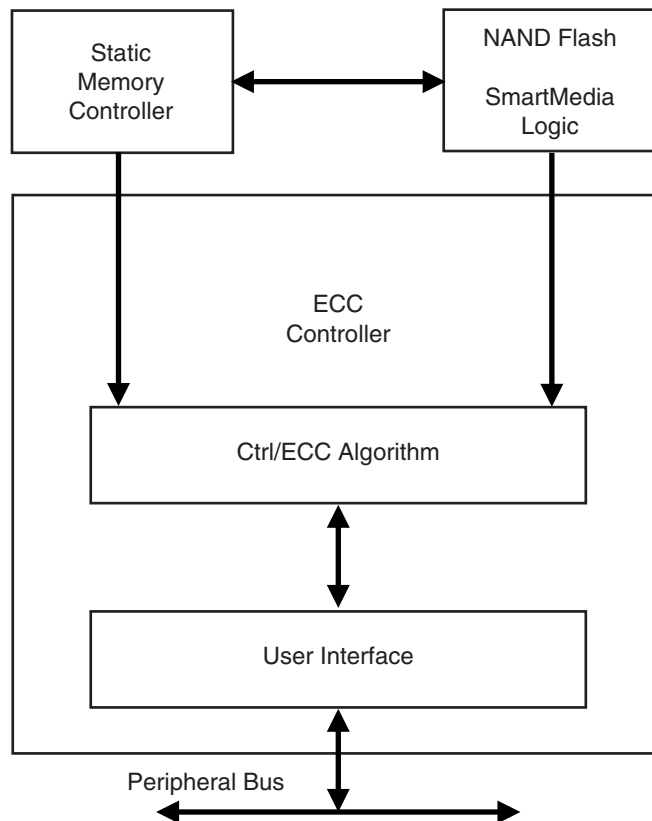

30.4 Functional Description

A page in NAND Flash and SmartMedia memories contains an area for main data and an additional area used for redundancy (ECC). The page is organized in 8-bit or 16-bit words. The page size corresponds to the number of words in the main data plus the number of words in the extra area used for redundancy.

The only configuration required for ECC is the NAND Flash or the SmartMedia page size (528/1056/2112/4224). Page size is configured setting the PAGESIZE field in the ECC Mode Register (MR).

ECC is automatically computed as soon as a read (00h)/write (80h) command to the NAND Flash or the SmartMedia is detected. Read and write access must start at a page boundary.

ECC is computed as soon as the counter reaches the page size. Values in the ECC Parity Register (PR) and ECC NParity Register (NPR) are then valid and locked until a new start condition (read/write command followed by five access address cycles).

30.4.1 Write Access

Once the flash memory page is written, the computed ECC code is available in the ECC Parity Error (PR) and ECC_NParity Error (NPR) registers. The ECC code value must be written by the software application at the end of the page, in the extra area used for redundancy.

30.4.2 Read Access

After reading main data in the page area, the application can perform read access to the extra area used for redundancy. Error detection is automatically performed by the ECC controller. The application can check the ECC Status Register (SR) for any detected errors.

It is up to the application to correct any detected error. ECC computation can detect four different circumstances:

- No error: XOR between the ECC computation and the ECC code stored at the end of the NAND Flash or SmartMedia page is equal to 0. No error flags in the ECC Status Register (SR).
- Recoverable error: Only the RECERR flag in the ECC Status register (SR) is set. The corrupted word offset in the read page is defined by the WORDADDR field in the ECC Parity Register (PR). The corrupted bit position in the concerned word is defined in the BITADDR field in the ECC Parity Register (PR).
- ECC error: The ECCERR flag in the ECC Status Register is set. An error has been detected in the ECC code stored in the Flash memory. The position of the corrupted bit can be found by the application performing an XOR between the Parity and the NParity contained in the ECC code stored in the flash memory.
- Non correctable error: The MULERR flag in the ECC Status Register is set. Several unrecoverable errors have been detected in the flash memory page.

ECC Status Register, ECC Parity Register and ECC NParity Register are cleared when a read/write command is detected or a software register is enabled.

For single bit Error Correction and double bit Error Detection (SEC-DED) hshiao code is used. 32-bit ECC is generated in order to perform one bit correction per 512/1024/2048/4096 8- or 16-bit

words. Of the 32 ECC bits, 26 bits are for line parity and 6 bits are for column parity. They are generated according to the schemes shown in [Figure 30-2](#) and [Figure 30-3](#).

Figure 30-2. Parity Generation for 512/1024/2048/4096 8-bit Words¹

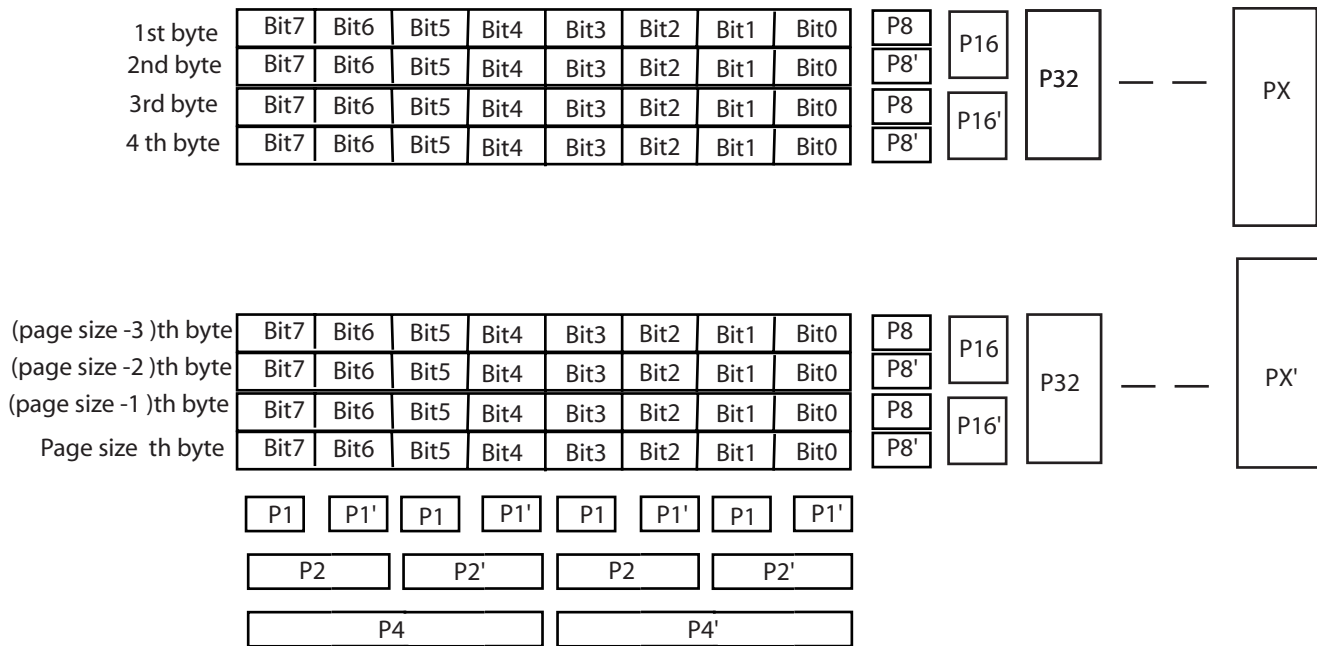

Page size = 512 Px = 2048
 Page size = 1024 Px = 4096
 Page size = 2048 Px = 8192
 Page size = 4096 Px = 16384

P1=bit7(+)+bit5(+)+bit3(+)+bit1(+)+P1
 P2=bit7(+)+bit6(+)+bit3(+)+bit2(+)+P2
 P4=bit7(+)+bit6(+)+bit5(+)+bit4(+)+P4
 P1'=bit6(+)+bit4(+)+bit2(+)+bit0(+)+P1'
 P2'=bit5(+)+bit4(+)+bit1(+)+bit0(+)+P2'
 P4'=bit7(+)+bit6(+)+bit5(+)+bit4(+)+P4'

To calculate P8' to PX' and P8 to PX, apply the algorithm that follows.

```

Page size = 2n

for i =0 to n
begin
for (j = 0 to page_size_byte)
begin
if(j[i] ==1)
P[2i+3]=bit7(+)+bit6(+)+bit5(+)+bit4(+)+bit3(+)+
bit2(+)+bit1(+)+bit0(+)+P[2i+3]
else
P[2i+3]'=bit7(+)+bit6(+)+bit5(+)+bit4(+)+bit3(+)+
bit2(+)+bit1(+)+bit0(+)+P[2i+3]'
end
end
    
```

Figure 30-3. Parity Generation for 512/1024/2048/4096 16-bit Words

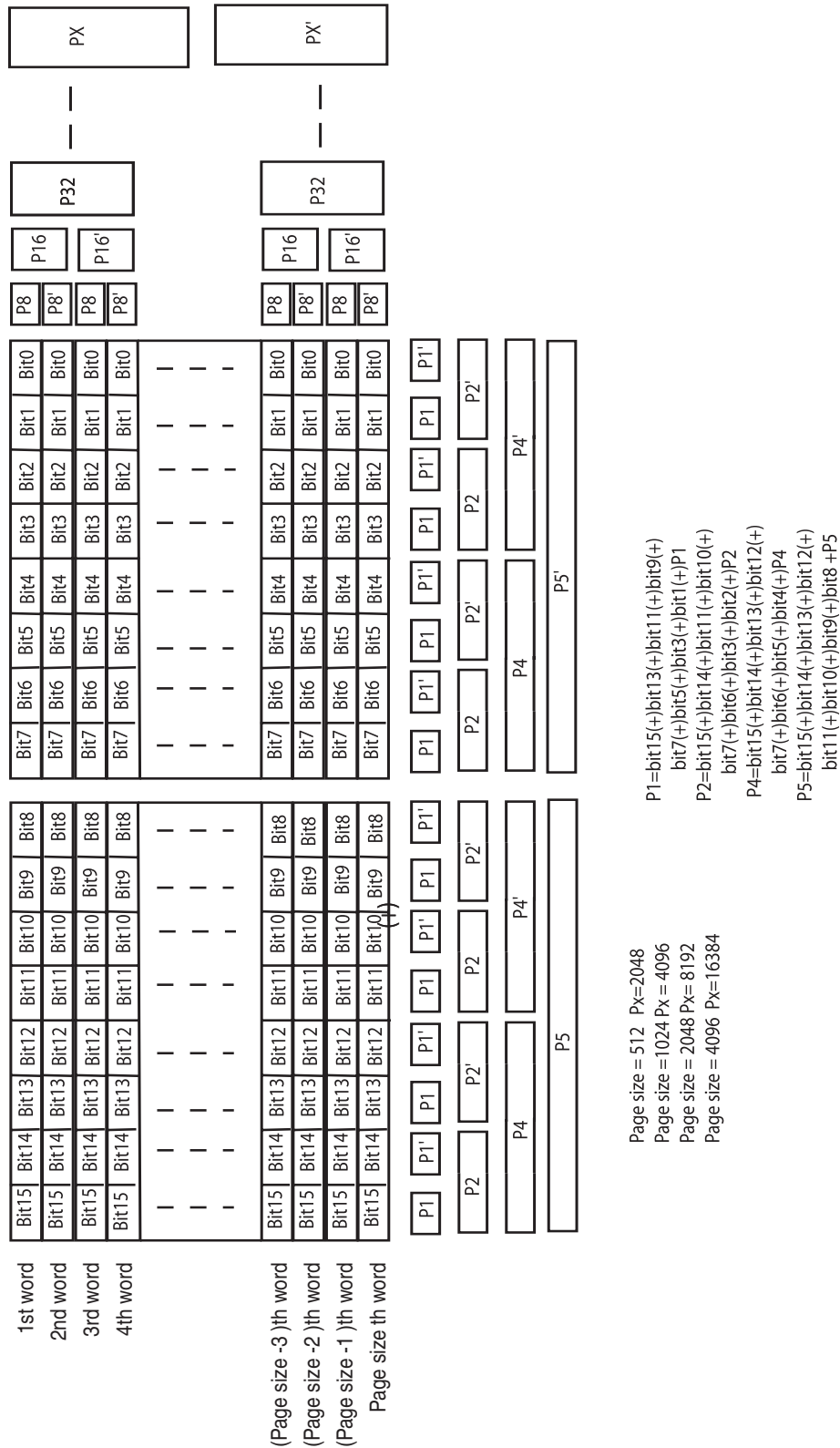

To calculate P8' to PX' and P8 to PX, apply the algorithm that follows.

```

Page size = 2n

for i =0 to n
begin
for (j = 0 to page_size_word)
begin
if(j[i] ==1)
P[2i+3] = bit15(+)bit14(+)bit13(+)bit12(+)
          bit11(+)bit10(+)bit9(+)bit8(+)
          bit7(+)bit6(+)bit5(+)bit4(+)bit3(+)
          bit2(+)bit1(+)bit0(+)P[2n+3]
else
P[2i+3]' =bit15(+)bit14(+)bit13(+)bit12(+)
          bit11(+)bit10(+)bit9(+)bit8(+)
          bit7(+)bit6(+)bit5(+)bit4(+)bit3(+)
          bit2(+)bit1(+)bit0(+)P[2i+3]'
end
end
end

```

30.5 ECC User Interface

Table 30-1. ECC Register Mapping

Offset	Register	Register Name	Access	Reset
0x00	ECC Control Register	CR	Write-only	0x0
0x04	ECC Mode Register	MR	Read/Write	0x0
0x08	ECC Status Register	SR	Read-only	0x0
0x0C	ECC Parity Register	PR	Read-only	0x0
0x10	ECC NParity Register	NPR	Read-only	0x0
0x14-0xF8	Reserved	–	–	–
0x14 - 0xFC	Reserved	–	–	–

30.5.1 ECC Control Register

Name: CR
Access Type: Write-only

31	30	29	28	27	26	25	24
–	–	–	–	–	–	–	–
23	22	21	20	19	18	17	16
–	–	–	–	–	–	–	–
15	14	13	12	11	10	9	8
–	–	–	–	–	–	–	–
7	6	5	4	3	2	1	0
–	–	–	–	–	–	–	RST

• **RST: RESET Parity**

Provides reset to current ECC by software.

0: No effect

1: Reset sECC Parity and ECC NParity register

30.5.2 ECC Mode Register

Register Name: MR
Access Type: Read/Write

31	30	29	28	27	26	25	24
–	–	–	–	–	–	–	–
23	22	21	20	19	18	17	16
–	–	–	–	–	–	–	–
15	14	13	12	11	10	9	8
–	–	–	–	–	–	–	–
7	6	5	4	3	2	1	0
–	–	–	–	–	–	PAGESIZE	

- **PAGESIZE: Page Size**

This field defines the page size of the NAND Flash device.

Page Size	Description
00	528 words
01	1056 words
10	2112 words
11	4224 words

A word has a value of 8 bits or 16 bits, depending on the NAND Flash or Smartmedia memory organization.

30.5.3 ECC Status Register

Register Name: SR

Access Type: Read-only

31	30	29	28	27	26	25	24
–	–	–	–	–	–	–	–
23	22	21	20	19	18	17	16
–	–	–	–	–	–	–	–
15	14	13	12	11	10	9	8
–	–	–	–	–	–	–	–
7	6	5	4	3	2	1	0
–	–	–	–	–	MULERR	ECCERR	RECERR

- **RECERR: Recoverable Error**

0: No Errors Detected

1: Errors Detected. If MULERR is 0, a single correctable error was detected. Otherwise multiple uncorrected errors were detected

- **ECCERR: ECC Error**

0: No Errors Detected

1: A single bit error occurred in the ECC bytes.

Read both ECC Parity and ECC Parityn register, the error occurred at the location which contains a 1 in the least significant 16 bits.

- **MULERR: Multiple Error**

0: No Multiple Errors Detected

1: Multiple Errors Detected

30.5.4 ECC Parity Register

Register Name: PR
Access Type: Read-only

31	30	29	28	27	26	25	24
–	–	–	–	–	–	–	–
23	22	21	20	19	18	17	16
–	–	–	–	–	–	–	–
15	14	13	12	11	10	9	8
WORDADDR							
7	6	5	4	3	2	1	0
WORDADDR				BITADDR			

During a page write, the value of the entire register must be written in the extra area used for redundancy (for a 512-byte page size: address 512-513)

- **BITADDR**

During a page read, this value contains the corrupted bit offset where an error occurred, if a single error was detected. If multiple errors were detected, this value is meaningless.

- **WORDADDR**

During a page read, this value contains the word address (8-bit or 16-bit word depending on the memory plane organization) where an error occurred, if a single error was detected. If multiple errors were detected, this value is meaningless.

30.5.5 ECC NParity Register

Register Name: NPR
Access Type: Read-only

31	30	29	28	27	26	25	24
–	–	–	–	–	–	–	–
23	22	21	20	19	18	17	16
–	–	–	–	–	–	–	–
15	14	13	12	11	10	9	8
NPARITY							
7	6	5	4	3	2	1	0
NPARITY							

• **NPARITY:**

During a write, the value of this register must be written in the extra area used for redundancy (for a 512-byte page size: address 514-515)

31. MultiMedia Card Interface (MCI)

Rev: 2.1.0.0

31.1 Features

- **Compatible with MultiMedia Card Specification Version 2.2**
- **Compatible with SD Memory Card Specification Version 1.0**
- **Compatible with MultiMedia Card Specification Version 3.31**
- **Compatible with SDIO Specification Version 1.1**
- **Cards Clock Rate Up to Master Clock Divided by 2**
- **Embedded Power Management to Slow Down Clock Rate When Not Used**
- **Supports 2 Multiplexed Slot(s)**
 - **Each Slot for either a MultiMediaCard Bus (Up to 30 Cards) or an SD Memory Card**
- **Support for Stream, Block and Multi-block Data Read and Write**
- **Supports Connection to DMA Controller**
 - **Minimizes Processor Intervention for Large Buffer Transfers**

31.2 Description

The MCI includes a command register, response registers, data registers, timeout counters and error detection logic that automatically handle the transmission of commands and, when required, the reception of the associated responses and data with a limited processor overhead.

The MCI supports stream, block and multi-block data read and write, and is compatible with a DMA Controller, minimizing processor intervention for large buffer transfers.

The MCI operates at a rate of up to Master Clock divided by 2 and supports the interfacing of 2 slot(s). Each slot may be used to interface with a MultiMedia Card bus (up to 30 Cards) or with a SD Memory Card. Only one slot can be selected at a time (slots are multiplexed). A bit field in the SD Card Register performs this selection.

The SD Memory Card communication is based on a 9-pin interface (clock, command, four data and three power lines) and the MultiMediaCard on a 7-pin interface (clock, command, one data, three power lines and one reserved for future use).

The SD Memory Card interface also supports MultiMedia Card operations. The main differences between SD and MultiMedia Cards are the initialization process and the bus topology.

31.3 Block Diagram

Figure 31-1. Block Diagram

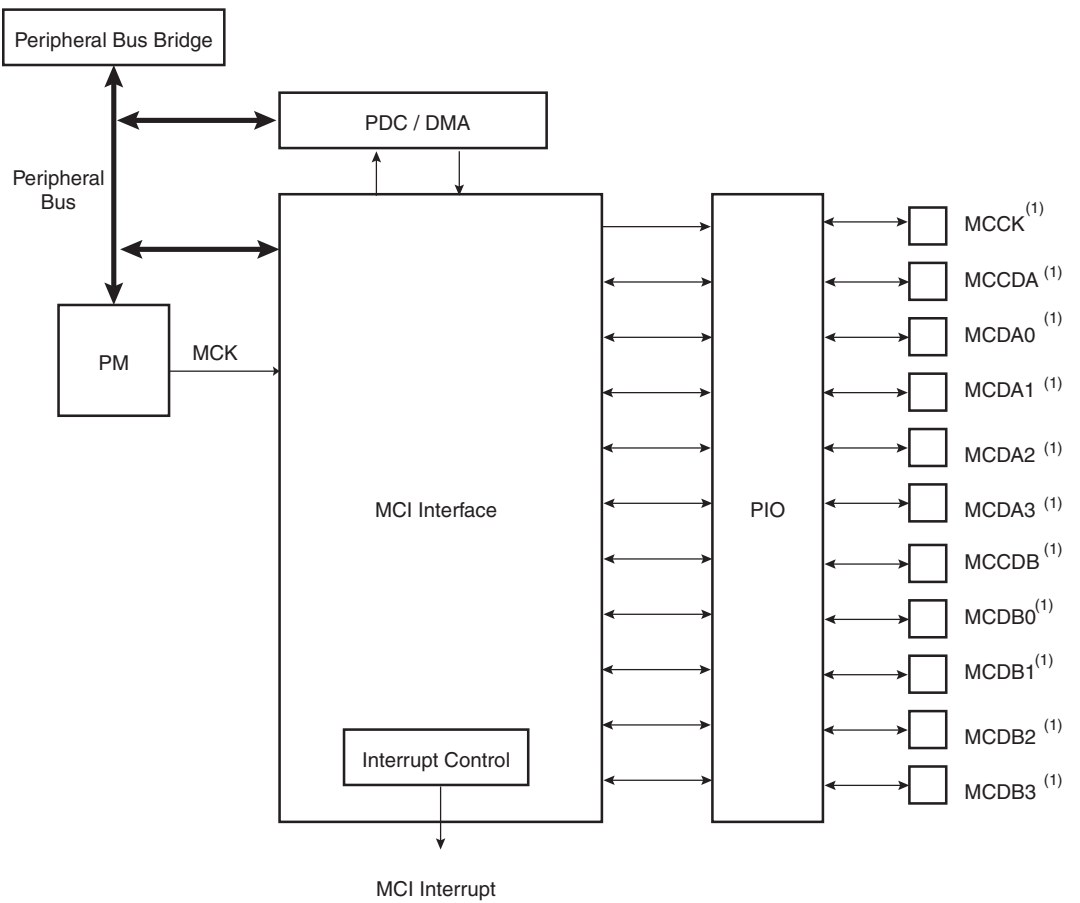

Note: 1. When several MCI (x MCI) are embedded in a product, MCCK refers to MCI x CK, MCCDA to MCI x CDA, MCDA_y to MC_ix DA_y, MCDB_y to MC_ix DB_y

31.4 Application Block Diagram

Figure 31-2. Application Block Diagram

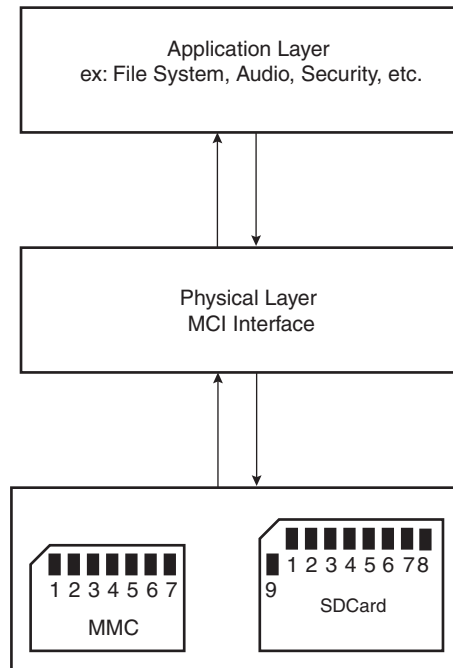

31.5 Pin Name List

Table 31-1. I/O Lines Description

Pin Name	Pin Description	Type ⁽¹⁾	Comments
MCCDA/MCCDB	Command/response	I/O/PP/OD	CMD of an MMC or SD Card
MCCK	Clock	I/O	CLK of an MMC or SD Card
MCDA0 - MCDA3	Data 0..3 of Slot A	I/O/PP	DAT0 of an MMC DAT[0..3] of an SD Card
MCDB0 - MCDB3	Data 0..3 of Slot B	I/O/PP	DAT0 of an MMC DAT[0..3] of an SD Card

Note: 1. I: Input, O: Output, PP: Push/Pull, OD: Open Drain.

31.6 Product Dependencies

31.6.1 I/O Lines

The pins used for interfacing the MultiMedia Cards or SD Cards may be multiplexed with PIO lines. The programmer must first program the PIO controllers to assign the peripheral functions to MCI pins.

31.6.2 Power Management

The MCI may receive a clock from the Power Manager (PM), so the programmer must first configure the PM to enable the MCI clock.

31.6.3 Interrupt

The MCI interface has an interrupt line connected to the Interrupt Controller (INTC).

Handling the MCI interrupt requires programming the INTC before configuring the MCI.

31.7 Bus Topology

Figure 31-3. Multimedia Memory Card Bus Topology

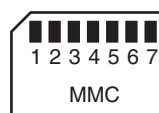

The MultiMedia Card communication is based on a 7-pin serial bus interface. It has three communication lines and four supply lines.

Table 31-2. Bus Topology

Pin Number	Name	Type ⁽¹⁾	Description	MCI Pin Name (Slot x)
1	RSV	NC	Not connected	
2	CMD	I/O/PP/OD	Command/response	MCCDx
3	VSS1	S	Supply voltage ground	VSS
4	VDD	S	Supply voltage	VDD
5	CLK	I/O	Clock	MCCK
6	VSS2	S	Supply voltage ground	VSS
7	DAT[0]	I/O/PP	Data 0	MCDx0

Note: 1. I: Input, O: Output, PP: Push/Pull, OD: Open Drain.
 2. When several MCI (x MCI) are embedded in a product, MCCK refers to MCI x CK, MCCDA to MCI x CDA, MCDAy to MCIx DAy, MCDBy to MCIx DBy

Figure 31-4. MMC Bus Connections (One Slot)

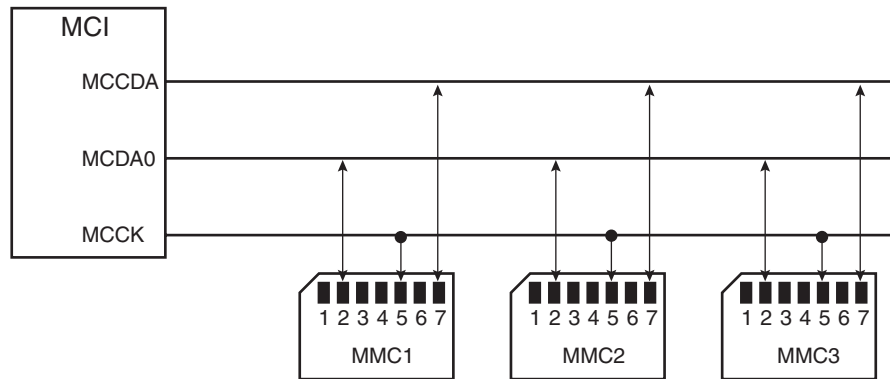

Note: 1. When several MCI (x MCI) are embedded in a product, MCCK refers to MCI x CK, MCCDA to MCI x CDA, MCDAy to MCIx DAy

Figure 31-5. SD Memory Card Bus Topology

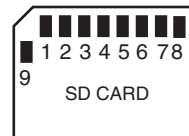

The SD Memory Card bus includes the signals listed in [Table 31-3 on page 565](#).

Table 31-3. SD Memory Card Bus Signals

Pin Number	Name	Type ⁽¹⁾	Description	MCI Pin Name (Slot x)
1	CD/DAT[3]	I/O/PP	Card detect/ Data line Bit 3	MCDx3
2	CMD	PP	Command/response	MCCDx
3	VSS1	S	Supply voltage ground	VSS
4	VDD	S	Supply voltage	VDD
5	CLK	I/O	Clock	MCCK
6	VSS2	S	Supply voltage ground	VSS
7	DAT[0]	I/O/PP	Data line Bit 0	MCDx0
8	DAT[1]	I/O/PP	Data line Bit 1 or Interrupt	MCDx1
9	DAT[2]	I/O/PP	Data line Bit 2	MCDx2

Note: 1. I: input, O: output, PP: Push Pull, OD: Open Drain

Figure 31-6. SD Card Bus Connections with Two Slots

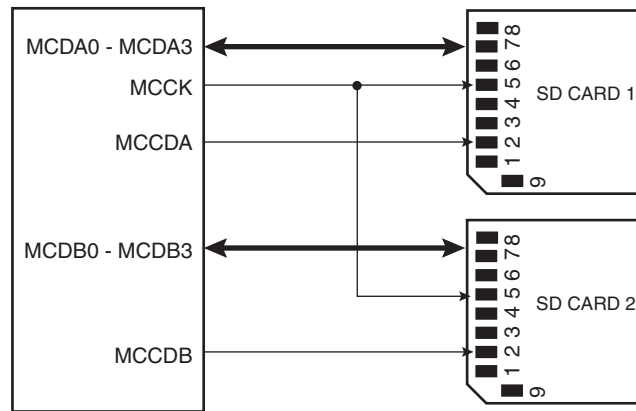

Note: 1. When several MCI (x MCI) are embedded in a product, MCK refers to MCI x CK, MCCDA to MCI x CDA, MCDAy to MCIx DAy, MCDBy to MCIx DBy

Figure 31-7. Mixing MultiMedia and SD Memory Cards with Two Slots

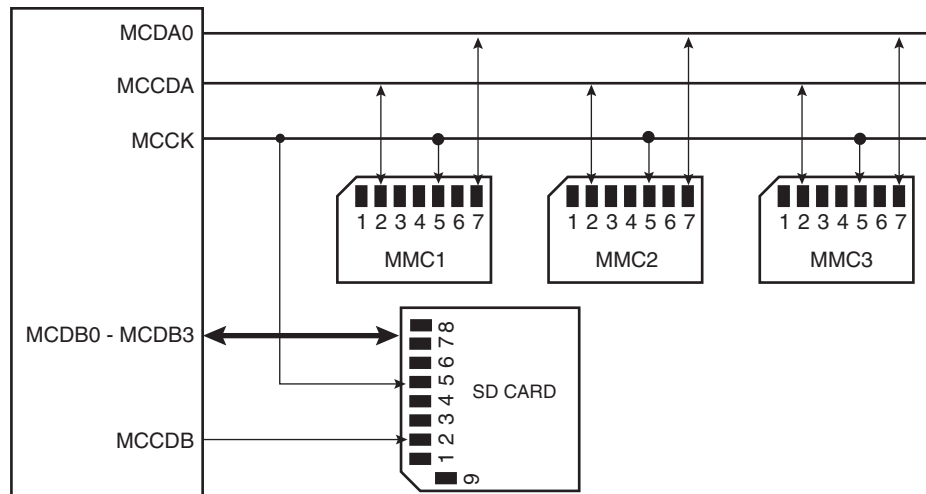

Note: 1. When several MCI (x MCI) are embedded in a product, MCK refers to MCI x CK, MCCDA to MCI x CDA, MCDAy to MCIx DAy, MCDBy to MCIx DBy

When the MCI is configured to operate with SD memory cards, the width of the data bus can be selected in the SDCR register. Clearing the SDCBUS bit in this register means that the width is one bit; setting it means that the width is four bits. In the case of multimedia cards, only the data line 0 is used. The other data lines can be used as independent PIOs.

31.8 MultiMedia Card Operations

After a power-on reset, the cards are initialized by a special message-based MultiMedia Card bus protocol. Each message is represented by one of the following tokens:

- **Command:** A command is a token that starts an operation. A command is sent from the host either to a single card (addressed command) or to all connected cards (broadcast command). A command is transferred serially on the CMD line.
- **Response:** A response is a token which is sent from an addressed card or (synchronously) from all connected cards to the host as an answer to a previously received command. A response is transferred serially on the CMD line.
- **Data:** Data can be transferred from the card to the host or vice versa. Data is transferred via the data line.

Card addressing is implemented using a session address assigned during the initialization phase by the bus controller to all currently connected cards. Their unique CID number identifies individual cards.

The structure of commands, responses and data blocks is described in the MultiMedia-Card System Specification. See also [Table 31-4 on page 568](#).

MultiMediaCard bus data transfers are composed of these tokens.

There are different types of operations. Addressed operations always contain a command and a response token. In addition, some operations have a data token; the others transfer their information directly within the command or response structure. In this case, no data token is present in an operation. The bits on the DAT and the CMD lines are transferred synchronous to the MCI Clock.

Two types of data transfer commands are defined:

- **Sequential commands:** These commands initiate a continuous data stream. They are terminated only when a stop command follows on the CMD line. This mode reduces the command overhead to an absolute minimum.
- **Block-oriented commands:** These commands send a data block succeeded by CRC bits.

Both read and write operations allow either single or multiple block transmission. A multiple block transmission is terminated when a stop command follows on the CMD line similarly to the sequential read or when a multiple block transmission has a predefined block count ([See "Data Transfer Operation" on page 569](#)).

The MCI provides a set of registers to perform the entire range of MultiMedia Card operations.

31.8.1 Command - Response Operation

After reset, the MCI is disabled and becomes valid after setting the MCIEN bit in the CR (MCI Control Register).

The PWSEN bit saves power by dividing the MCI clock by $2^{PWSDIV} + 1$ when the bus is inactive.

The two bits RDPROOF and WRPROOF in the MCI Mode Register (MR) allow stopping the MCI Clock during read or write access if the internal FIFO is full. This will guarantee data integrity, not bandwidth.

The command and the response of the card are clocked out with the rising edge of the MCI Clock.

All the timings for MultiMedia Card are defined in the MultiMediaCard System Specification. The two bus modes (open drain and push/pull) needed to process all the operations are defined in the MCI command register. The CMDR allows a command to be carried out.

For example, to perform an ALL_SEND_CID command:

CMD	Host Command					N _{ID} Cycles			CID					
	S	T	Content	CRC	E	Z	*****	Z	S	T	Content	Z	Z	Z

The command ALL_SEND_CID and the fields and values for the CMDR Control Register are described in [Table 31-4](#) and [Table 31-5](#).

Table 31-4. ALL_SEND_CID Command Description

CMD Index	Type	Argument	Resp	Abbreviation	Command Description
CMD2	bcr	[31:0] stuff bits	R2	ALL_SEND_CID	Asks all cards to send their CID numbers on the CMD line

Note: bcr means broadcast command with response.

Table 31-5. Fields and Values for CMDR Command Register

Field	Value
CMDNB (command number)	2 (CMD2)
RSPTYP (response type)	2 (R2: 136 bits response)
SPCMD (special command)	0 (not a special command)
OPCMD (open drain command)	1
MAXLAT (max latency for command to response)	0 (NID cycles ==> 5 cycles)
TRCMD (transfer command)	0 (No transfer)
TRDIR (transfer direction)	X (available only in transfer command)
TRTYP (transfer type)	X (available only in transfer command)

The ARGR contains the argument field of the command.

To send a command, the user must perform the following steps:

- Fill the argument register (ARGR) with the command argument.
- Set the command register (CMDR) (see [Table 31-5](#)).

The command is sent immediately after writing the command register. The status bit CMDRDY in the status register (SR) is asserted when the command is completed. If the command requires a response, it can be read in the MCI response register (RSPR). The response size can be from 48 bits up to 136 bits depending on the command. The MCI embeds an error detection to prevent any corrupted data during the transfer.

The following flowchart shows how to send a command to the card and read the response if needed. In this example, the status register bits are polled but setting the appropriate bits in the interrupt enable register (IER) allows using an interrupt method.

Figure 31-8. Command/Response Functional Flow Diagram

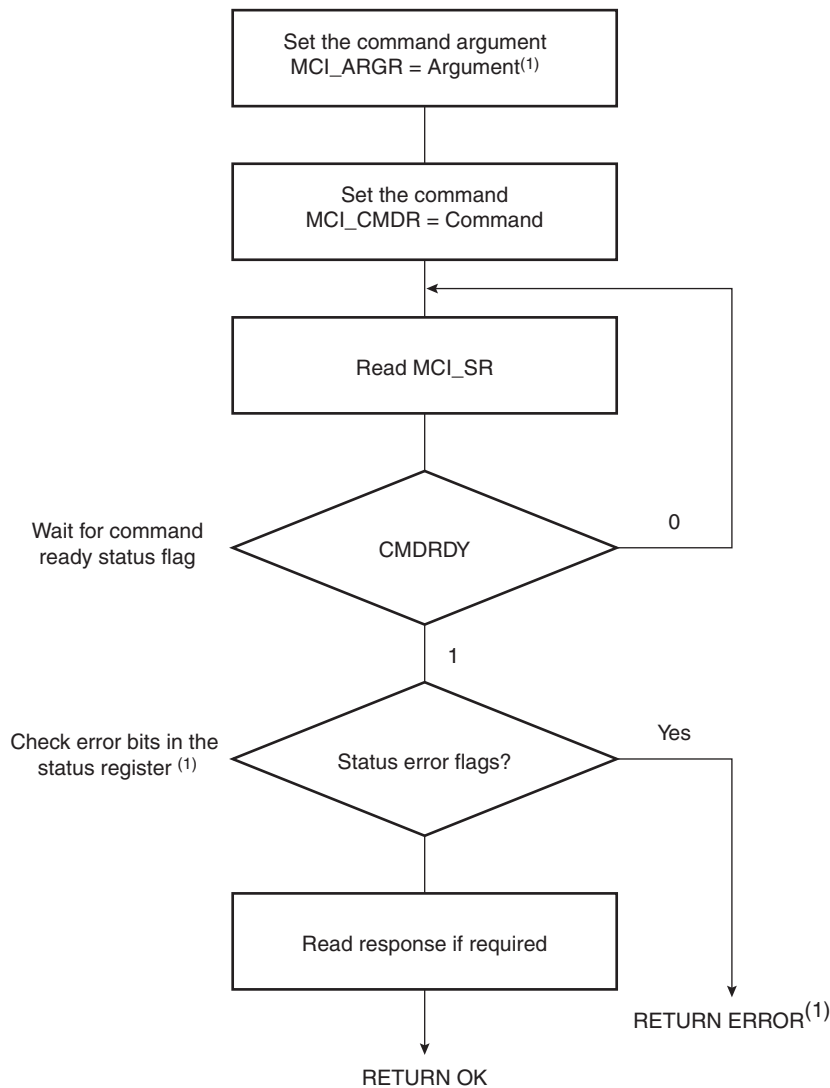

Note: 1. If the command is SEND_OP_COND, the CRC error flag is always present (refer to R3 response in the MultiMedia Card specification).

31.8.2 Data Transfer Operation

The MultiMedia Card allows several read/write operations (single block, multiple blocks, stream, etc). These kind of transfers can be selected setting the Transfer Type (TRTYP) field in the MCI Command Register (CMDR).

These operations can be done using the a DMA Controller.

In all cases, the block length (BLKLEN field) must be defined either in the mode register MR, or in the Block Register BLKR. This field determines the size of the data block.

Consequent to MMC Specification 3.1, two types of multiple block read (or write) transactions are defined (the host can use either one at any time):

- Open-ended/Infinite Multiple block read (or write):
The number of blocks for the read (or write) multiple block operation is not defined. The card will continuously transfer (or program) data blocks until a stop transmission command is received.
- Multiple block read (or write) with pre-defined block count (since version 3.1 and higher):
The card will transfer (or program) the requested number of data blocks and terminate the transaction. The stop command is not required at the end of this type of multiple block read (or write), unless terminated with an error. In order to start a multiple block read (or write) with pre-defined block count, the host must correctly program the MCI Block Register (BLKR). Otherwise the card will start an open-ended multiple block read. The BCNT field of the Block Register defines the number of blocks to transfer (from 1 to 65535 blocks). Programming the value 0 in the BCNT field corresponds to an infinite block transfer.

31.8.3 Read Operation

The following flowchart shows how to read a single block with or without use of DMA facilities. In this example, a polling method is used to wait for the end of read. Similarly, the user can configure the interrupt enable register (IER) to trigger an interrupt at the end of read.

Figure 31-9. Read Functional Flow Diagram

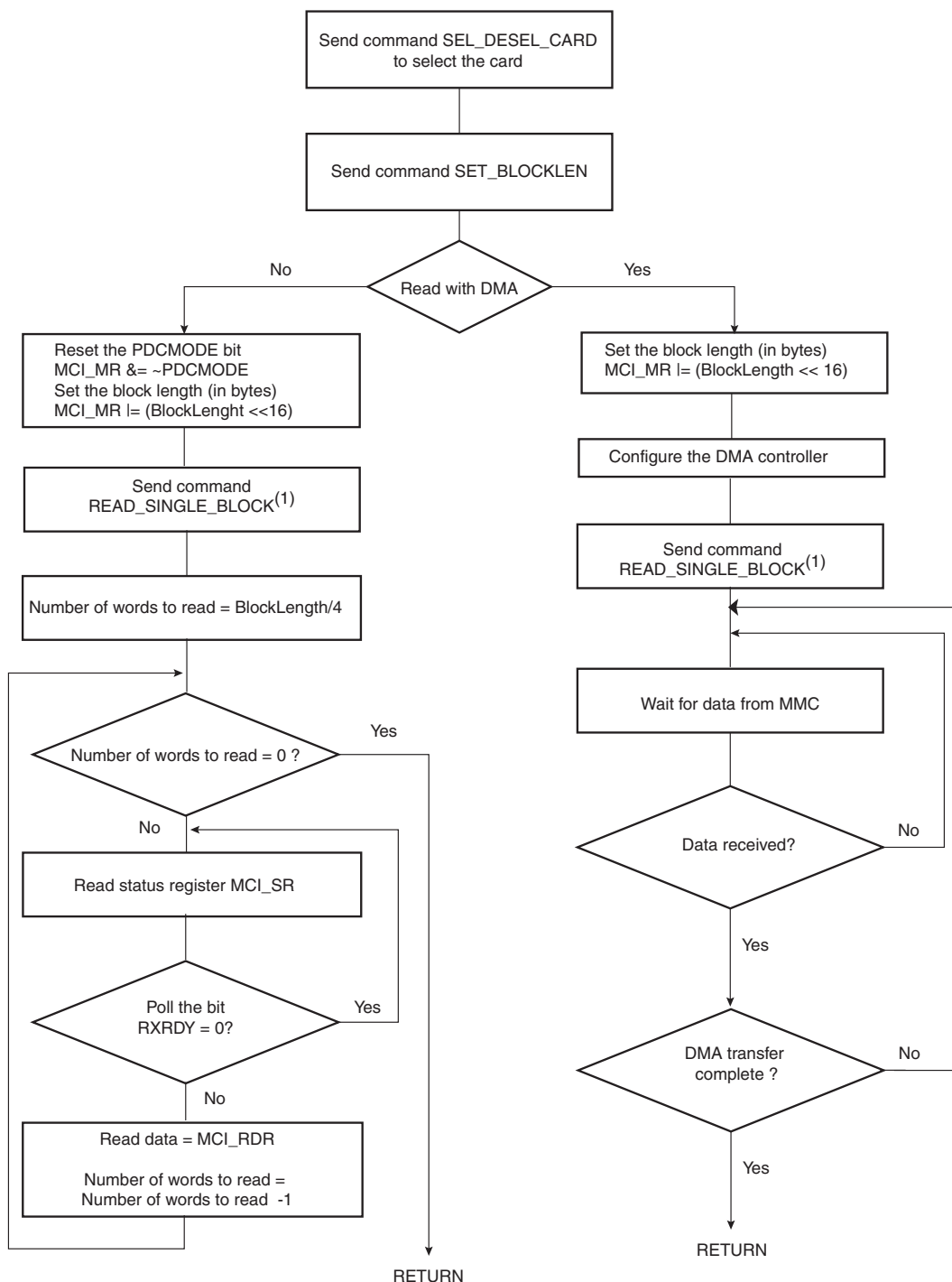

Note: 1. This command is supposed to have been correctly sent (see Figure 31-8).

31.8.4 Write Operation

In write operation, the MCI Mode Register (MR) is used to define the padding value when writing non-multiple block size. If the bit DMAPADV is 0, then 0x00 value is used when padding data, otherwise 0xFF is used.

The following flowchart shows how to write a single block with or without use of DMA facilities. Polling or interrupt method can be used to wait for the end of write according to the contents of the Interrupt Mask Register (IMR).

Figure 31-10. Write Functional Flow Diagram

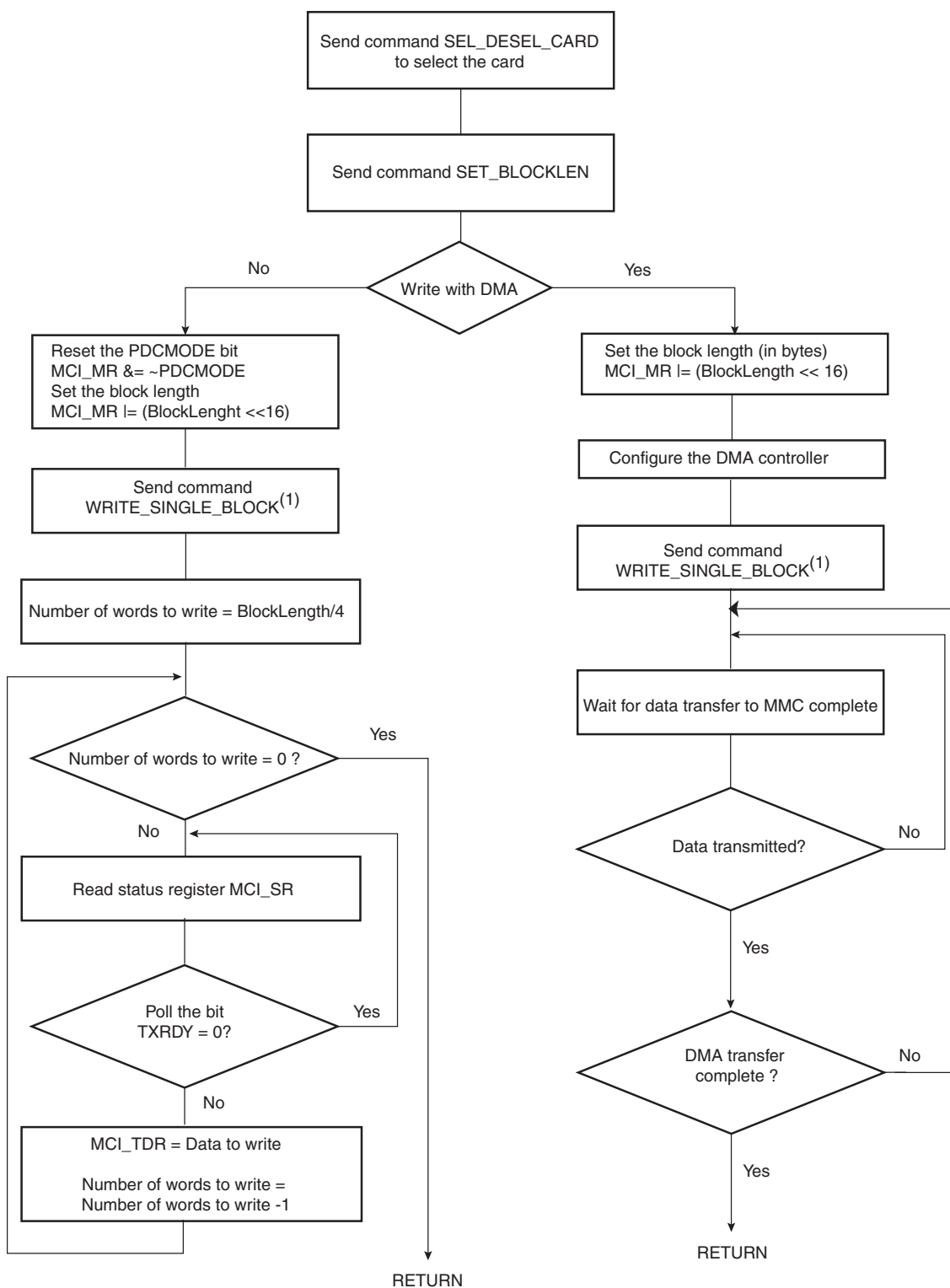

Note: 1. It is assumed that this command has been correctly sent (see Figure 31-8).

31.9 SD Card Operations

The MultiMedia Card Interface allows processing of SD Memory (Secure Digital Memory Card) and SDIO (SD Input Output) Card commands.

SD/SDIO cards are based on the Multi Media Card (MMC) format, but are physically slightly thicker and feature higher data transfer rates, a lock switch on the side to prevent accidental overwriting and security features. The physical form factor, pin assignment and data transfer protocol are forward-compatible with the MultiMedia Card with some additions. SD slots can actually be used for more than flash memory cards. Devices that support SDIO can use small devices designed for the SD form factor, such as GPS receivers, Wi-Fi or Bluetooth adapters, modems, barcode readers, IrDA adapters, FM radio tuners, RFID readers, digital cameras and more.

SD/SDIO is covered by numerous patents and trademarks, and licensing is only available through the Secure Digital Card Association.

The SD/SDIO Card communication is based on a 9-pin interface (Clock, Command, 4 x Data and 3 x Power lines). The communication protocol is defined as a part of this specification. The main difference between the SD/SDIO Card and the MultiMedia Card is the initialization process.

The SD/SDIO Card Register (SDCR) allows selection of the Card Slot and the data bus width.

The SD/SDIO Card bus allows dynamic configuration of the number of data lines. After power up, by default, the SD/SDIO Card uses only DAT0 for data transfer. After initialization, the host can change the bus width (number of active data lines).

31.9.1 SDIO Data Transfer Type

SDIO cards may transfer data in either a multi-byte (1 to 512 bytes) or an optional block format (1 to 511 blocks), while the SD memory cards are fixed in the block transfer mode. The TRTYP field in the MCI Command Register (CMDR) allows to choose between SDIO Byte or SDIO Block transfer.

The number of bytes/blocks to transfer is set through the BCNT field in the MCI Block Register (BLKR). In SDIO Block mode, the field BLKLEN must be set to the data block size while this field is not used in SDIO Byte mode.

An SDIO Card can have multiple I/O or combined I/O and memory (called Combo Card). Within a multi-function SDIO or a Combo card, there are multiple devices (I/O and memory) that share access to the SD bus. In order to allow the sharing of access to the host among multiple devices, SDIO and combo cards can implement the optional concept of suspend/resume (Refer to the SDIO Specification for more details). To send a suspend or a resume command, the host must set the SDIO Special Command field (IOSPCMD) in the MCI Command Register.

31.9.2 SDIO Interrupts

Each function within an SDIO or Combo card may implement interrupts (Refer to the SDIO Specification for more details). In order to allow the SDIO card to interrupt the host, an interrupt function is added to a pin on the DAT[1] line to signal the card's interrupt to the host. An SDIO interrupt on each slot can be enabled through the MCI Interrupt Enable Register. The SDIO interrupt is sampled regardless of the currently selected slot.

31.10 MultiMedia Card Interface (MCI) User Interface

Table 31-6. Register Mapping

Offset	Register	Register Name	Read/Write	Reset
0x00	Control Register	CR	Write	–
0x04	Mode Register	MR	Read/write	0x0
0x08	Data Timeout Register	DTOR	Read/write	0x0
0x0C	SD/SDIO Card Register	SDCR	Read/write	0x0
0x10	Argument Register	ARGR	Read/write	0x0
0x14	Command Register	CMDR	Write	–
0x18	Block Register	BLKR	Read/write	-
0x1C	Reserved	–	–	–
0x20	Response Register ⁽¹⁾	RSPR ⁽¹⁾	Read	0x0
0x24	Response Register ⁽¹⁾	RSPR ⁽¹⁾	Read	0x0
0x28	Response Register ⁽¹⁾	RSPR ⁽¹⁾	Read	0x0
0x2C	Response Register ⁽¹⁾	RSPR ⁽¹⁾	Read	0x0
0x30	Receive Data Register	RDR	Read	0x0
0x34	Transmit Data Register	TDR	Write	–
0x38 - 0x3C	Reserved	–	–	–
0x40	Status Register	SR	Read	0xC0E5
0x44	Interrupt Enable Register	IER	Write	–
0x48	Interrupt Disable Register	IDR	Write	–
0x4C	Interrupt Mask Register	IMR	Read	0x0

Note: 1. The response register can be read by N accesses at the same RSPR or at consecutive addresses (0x20 to 0x2C). N depends on the size of the response.

31.10.1 MCI Control Register

Name: CR

Access Type: Write-only

31	30	29	28	27	26	25	24
–	–	–	–	–	–	–	–
23	22	21	20	19	18	17	16
–	–	–	–	–	–	–	–
15	14	13	12	11	10	9	8
–	–	–	–	–	–	–	–
7	6	5	4	3	2	1	0
SWRST	–	–	–	PWSDIS	PWSEN	MCIDIS	MCIEN

- **MCIEN: Multi-Media Interface Enable**

0 = No effect.

1 = Enables the Multi-Media Interface if MCDIS is 0.

- **MCIDIS: Multi-Media Interface Disable**

0 = No effect.

1 = Disables the Multi-Media Interface.

- **PWSEN: Power Save Mode Enable**

0 = No effect.

1 = Enables the Power Saving Mode if PWSDIS is 0.

Warning: Before enabling this mode, the user must set a value different from 0 in the PWSDIV field (Mode Register MR) .

- **PWSDIS: Power Save Mode Disable**

0 = No effect.

1 = Disables the Power Saving Mode.

- **SWRST: Software Reset**

0 = No effect.

1 = Resets the MCI. A software triggered hardware reset of the MCI interface is performed.

31.10.2 MCI Mode Register

Name: MR
Access Type: Read/write

31	30	29	28	27	26	25	24
BLKLEN							
23	22	21	20	19	18	17	16
BLKLEN							
15	14	13	12	11	10	9	8
-	DMAPADV	-	WRPROOF	RDPROOF	PWSDIV		
7	6	5	4	3	2	1	0
CLKDIV							

- **CLKDIV: Clock Divider**

Multimedia Card Interface clock (MCCK) is Master Clock (MCK) divided by $(2^{*(CLKDIV+1)})$.

- **PWSDIV: Power Saving Divider**

Multimedia Card Interface clock is divided by $2^{(PWSDIV)} + 1$ when entering Power Saving Mode.

Warning: This value must be different from 0 before enabling the Power Save Mode in the CR (PWSEN bit).

- **RDPROOF Read Proof Enable**

Enabling Read Proof allows to stop the MCI Clock during read access if the internal FIFO is full. This will guarantee data integrity, not bandwidth.

0 = Disables Read Proof.

1 = Enables Read Proof.

- **WRPROOF Write Proof Enable**

Enabling Write Proof allows to stop the MCI Clock during write access if the internal FIFO is full. This will guarantee data integrity, not bandwidth.

0 = Disables Write Proof.

1 = Enables Write Proof.

- **DMAPADV: DMA Padding Value**

0 = 0x00 value is used when padding data in write transfer.

1 = 0xFF value is used when padding data in write transfer.

- **BLKLEN: Data Block Length**

This field determines the size of the data block.

This field is also accessible in the MCI Block Register (BLKR).

Bits 16 and 17 must be written to 0.

Note: In SDIO Byte mode, BLKLEN field is not used.

31.10.3 MCI Data Timeout Register

Name: DTOR

Access Type: Read/write

31	30	29	28	27	26	25	24
–	–	–	–	–	–	–	–
23	22	21	20	19	18	17	16
–	–	–	–	–	–	–	–
15	14	13	12	11	10	9	8
–	–	–	–	–	–	–	–
7	6	5	4	3	2	1	0
–	DTOMUL			DTOCYC			

- **DTOCYC: Data Timeout Cycle Number**
- **DTOMUL: Data Timeout Multiplier**

These fields determine the maximum number of Master Clock cycles that the MCI waits between two data block transfers. It equals (DTCYC x Multiplier).

Multiplier is defined by DTOMUL as shown in the following table:

DTOMUL			Multiplier
0	0	0	1
0	0	1	16
0	1	0	128
0	1	1	256
1	0	0	1024
1	0	1	4096
1	1	0	65536
1	1	1	1048576

If the data time-out set by DTOCYC and DTOMUL has been exceeded, the Data Time-out Error flag (DTOE) in the MCI Status Register (SR) raises.

31.10.4 MCI SD Card/SDIO Register

Name: SDCR

Access Type: Read/write

31	30	29	28	27	26	25	24
–	–	–	–	–	–	–	–
23	22	21	20	19	18	17	16
–	–	–	–	–	–	–	–
15	14	13	12	11	10	9	8
–	–	–	–	–	–	–	–
7	6	5	4	3	2	1	0
SDCBUS	–	–	–	SDCSEL			

- **SDCSEL: SD Card Selector**

0 = SDCARD Slot A selected.

1 = SDCARD Slot B selected.

- **SDCBUS: SD Card/SDIO Bus Width**

0 = 1-bit data bus

1 = 4-bit data bus

31.10.5 MCI Argument Register

Name: ARGR

Access Type: Read/write

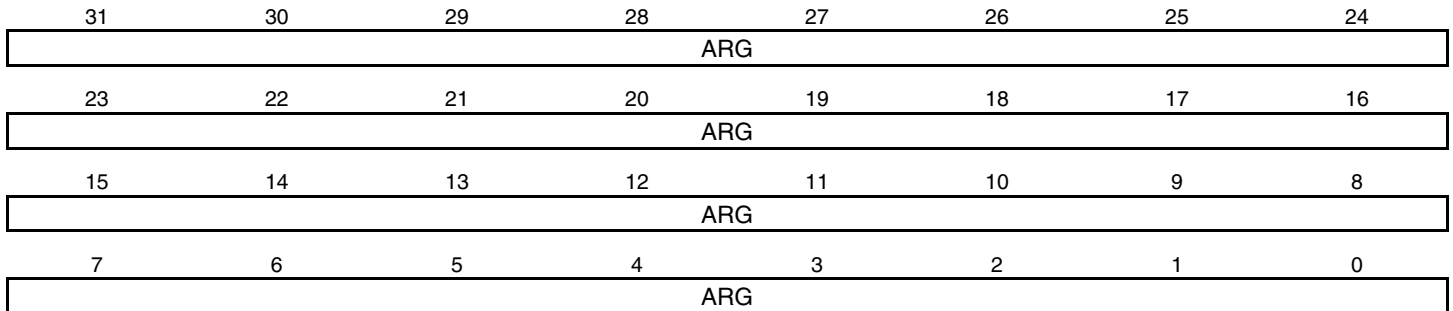

- ARG: Command Argument

31.10.6 MCI Command Register

Name: CMDR
Access Type: Write-only

31	30	29	28	27	26	25	24
–	–	–	–	–	–	IOSPCMD	
23	22	21	20	19	18	17	16
–	–	TRTYP			TRDIR	TRCMD	
15	14	13	12	11	10	9	8
–	–	–	MAXLAT	OPDCMD	SPCMD		
7	6	5	4	3	2	1	0
RSPTYP		CMDNB					

This register is write-protected while CMDRDY is 0 in SR. If an Interrupt command is sent, this register is only writeable by an interrupt response (field SPCMD). This means that the current command execution cannot be interrupted or modified.

- **CMDNB: Command Number**
- **RSPTYP: Response Type**

RSP		Response Type
0	0	No response.
0	1	48-bit response.
1	0	136-bit response.
1	1	Reserved.

- **SPCMD: Special Command**

SPCMD			Command
0	0	0	Not a special CMD.
0	0	1	Initialization CMD: 74 clock cycles for initialization sequence.
0	1	0	Synchronized CMD: Wait for the end of the current data block transfer before sending the pending command.
0	1	1	Reserved.
1	0	0	Interrupt command: Corresponds to the Interrupt Mode (CMD40).
1	0	1	Interrupt response: Corresponds to the Interrupt Mode (CMD40).

- **OPDCMD: Open Drain Command**

0 = Push pull command

1 = Open drain command

- **MAXLAT: Max Latency for Command to Response**

0 = 5-cycle max latency

1 = 64-cycle max latency

- **TRCMD: Transfer Command**

TRCMD		Transfer Type
0	0	No data transfer
0	1	Start data transfer
1	0	Stop data transfer
1	1	Reserved

- **TRDIR: Transfer Direction**

0 = Write

1 = Read

- **TRTYP: Transfer Type**

TRTYP			Transfer Type
0	0	0	MMC/SDCard Single Block
0	0	1	MMC/SDCard Multiple Block
0	1	0	MMC Stream
0	1	1	Reserved
1	0	0	SDIO Byte
1	0	1	SDIO Block
1	1	0	Reserved
1	1	1	Reserved

- **IOSPCMD: SDIO Special Command**

IOSPCMD		SDIO Special Command Type
0	0	Not a SDIO Special Command
0	1	SDIO Suspend Command
1	0	SDIO Resume Command
1	1	Reserved

31.10.7 MCI Block Register

Name: BLKR

Access Type: Read/write

31	30	29	28	27	26	25	24
BLKLEN							
23	22	21	20	19	18	17	16
BLKLEN							
15	14	13	12	11	10	9	8
BCNT							
7	6	5	4	3	2	1	0
BCNT							

- **BCNT: MMC/SDIO Block Count - SDIO Byte Count**

This field determines the number of data byte(s) or block(s) to transfer.

The transfer data type and the authorized values for BCNT field are determined by the TRTYP field in the MCI Command Register (CMDR):

TRTYP			Type of Transfer	BCNT Authorized Values
0	0	1	MMC/SDCard Multiple Block	From 1 to MCI_MAXNUM_BLK: Value 0 corresponds to an infinite block transfer.
1	0	0	SDIO Byte	From 1 to 512 bytes: Value 0 corresponds to a 512-byte transfer. Values from 0x200 to 0xFFFF are forbidden.
1	0	1	SDIO Block	From 1 to 511 blocks: Value 0 corresponds to an infinite block transfer. Values from 0x200 to 0xFFFF are forbidden.
Other values			-	Reserved.

Warning: In SDIO Byte and Block modes, writing to the 7 last bits of BCNT field, is forbidden and may lead to unpredictable results.

- **BLKLEN: Data Block Length**

This field determines the size of the data block.

This field is also accessible in the MCI Mode Register (MR).

Bits 16 and 17 must be set to 0 if PDCFBYTE is disabled.

Note: In SDIO Byte mode, BLKLEN field is not used.

31.10.8 MCI Response Register

Name: RSPR
Access Type: Read-only

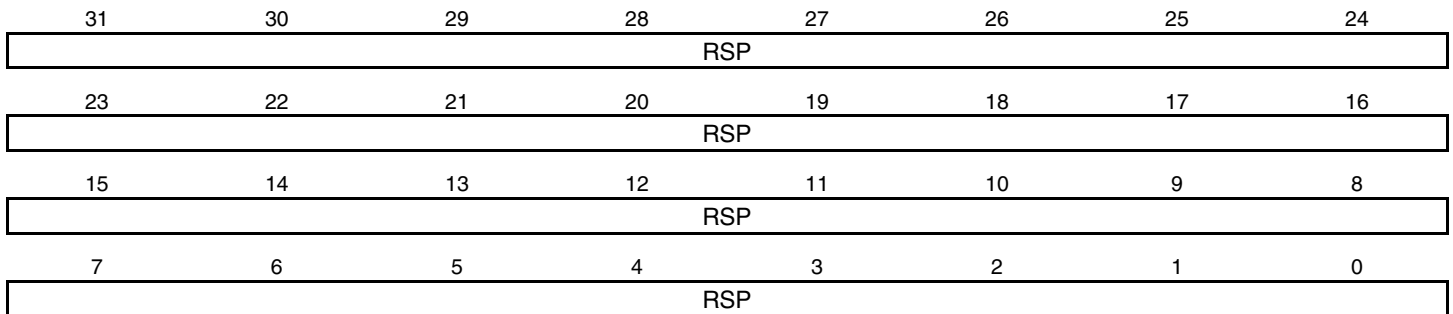

• **RSP: Response**

Note: 1. The response register can be read by N accesses at the same RSPR or at consecutive addresses (0x20 to 0x2C).
 N depends on the size of the response.

31.10.9 MCI Receive Data Register

Name: RDR

Access Type: Read-only

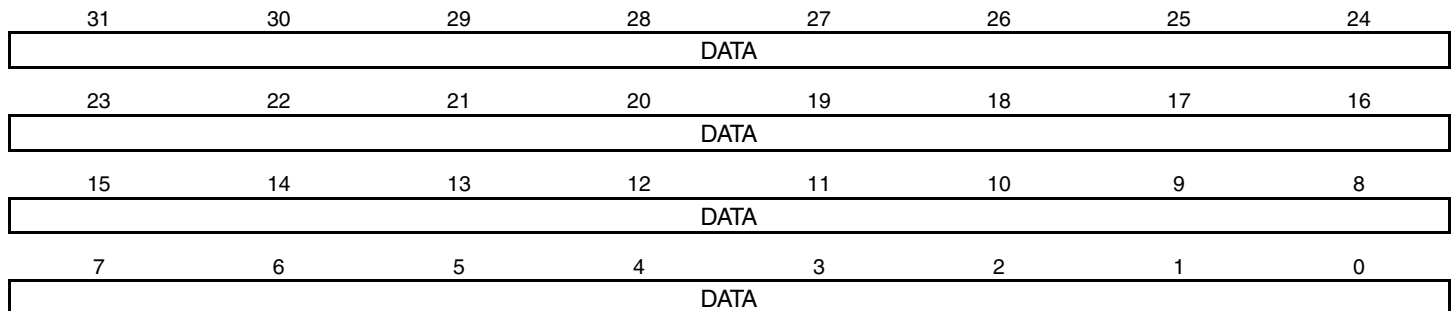

- DATA: Data to Read

31.10.10 MCI Transmit Data Register

Name: TDR

Access Type: Write-only

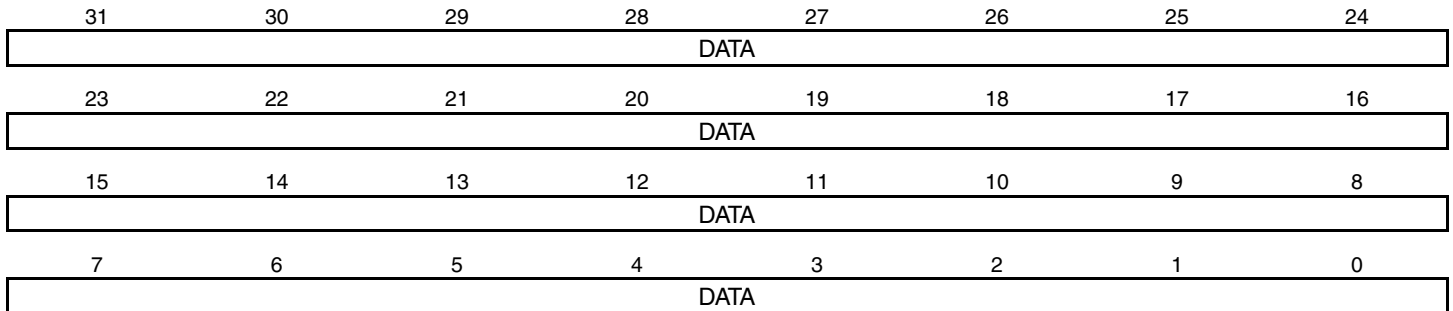

- DATA: Data to Write

31.10.11 MCI Status Register

Name: SR

Access Type: Read-only

31	30	29	28	27	26	25	24
UNRE	OVRE	–	–	–	–	–	–
23	22	21	20	19	18	17	16
–	DTOE	DCRCE	RTOE	RENDE	RCRCE	RDIRE	RINDE
15	14	13	12	11	10	9	8
–	–	–	–	–	–	SDIOIRQB	SDIOIRQA
7	6	5	4	3	2	1	0
–	–	NOTBUSY	DTIP	BLKE	TXRDY	RXRDY	CMDRDY

- **CMDRDY: Command Ready**

0 = A command is in progress.

1 = The last command has been sent. Cleared when writing in the CMDR.

- **RXRDY: Receiver Ready**

0 = No data has been received since the last read of RDR.

1 = Data has been received since the last read of RDR.

- **TXRDY: Transmit Ready**

0= The last data written in TDR has not yet been transferred in the Shift Register.

1= The last data written in TDR has been transferred in the Shift Register.

- **BLKE: Data Block Ended**

This flag must be used only for Write Operations.

0 = A data block transfer is not yet finished. Cleared when reading the SR.

1 = A data block transfer has ended, including the CRC16 Status transmission.

The flag is set for each transmitted CRC Status.

Refer to the MMC or SD Specification for more details concerning the CRC Status.

For the read operations, the BLKE flag is set for each received CRC.

- **DTIP: Data Transfer in Progress**

0 = No data transfer in progress.

1 = The current data transfer is still in progress, including CRC16 calculation. Cleared at the end of the CRC16 calculation.

- **NOTBUSY: Data Not Busy**

This flag must be used only for Write Operations.

A block write operation uses a simple busy signalling of the write operation duration on the data (DAT0) line: during a data transfer block, if the card does not have a free data receive buffer, the card indicates this condition by pulling down the data line (DAT0) to LOW. The card stops pulling down the data line as soon as at least one receive buffer for the defined data transfer block length becomes free.

The NOTBUSY flag allows to deal with these different states.

0 = The MCI is not ready for new data transfer. Cleared at the end of the card response.

1 = The MCI is ready for new data transfer. Set when the busy state on the data line has ended. This corresponds to a free internal data receive buffer of the card.

Refer to the MMC or SD Specification for more details concerning the busy behavior.

For all the read operations, the NOTBUSY flag is cleared at the end of the host command.

For the Infinite Read Multiple Blocks, the NOTBUSY flag is set at the end of the STOP_TRANSMISSION host command (CMD12).

For the Single Block Reads, the NOTBUSY flag is set at the end of the data read block.

For the Multiple Block Reads with pre-defined block count, the NOTBUSY flag is set at the end of the last received data block.

- **RINDE: Response Index Error**

0 = No error.

1 = A mismatch is detected between the command index sent and the response index received. Cleared when writing in the CMDR.

- **RDIRE: Response Direction Error**

0 = No error.

1 = The direction bit from card to host in the response has not been detected.

- **RCRCE: Response CRC Error**

0 = No error.

1 = A CRC7 error has been detected in the response. Cleared when writing in the CMDR.

- **RENDE: Response End Bit Error**

0 = No error.

1 = The end bit of the response has not been detected. Cleared when writing in the CMDR.

- **RTOE: Response Time-out Error**

0 = No error.

1 = The response time-out set by MAXLAT in the CMDR has been exceeded. Cleared when writing in the CMDR.

- **DCRCE: Data CRC Error**

0 = No error.

1 = A CRC16 error has been detected in the last data block. Cleared when reading SR.

- **DTOE: Data Time-out Error**

0 = No error.

1 = The data time-out set by DTOCYC and DTOMUL in DTOR has been exceeded. Cleared when reading SR.

- **OVRE: Overrun**

0 = No error.

1 = At least one 8-bit received data has been lost (not read). Cleared when sending a new data transfer command.

- **UNRE: Underrun**

0 = No error.

1 = At least one 8-bit data has been sent without valid information (not written). Cleared when sending a new data transfer command.

- **SDIOIRQA: SDIO Interrupt for Slot A**

0 = No interrupt detected on SDIO Slot A.

1 = A SDIO Interrupt on Slot A has reached. Cleared when reading the SR.

- **SDIOIRQB: SDIO Interrupt for Slot B**

0 = No interrupt detected on SDIO Slot B.

1 = A SDIO Interrupt on Slot B has reached. Cleared when reading the SR.

31.10.12 MCI Interrupt Enable Register

Name: IER

Access Type: Write-only

31	30	29	28	27	26	25	24
UNRE	OVRE	–	–	–	–	–	–
23	22	21	20	19	18	17	16
–	DTOE	DCRCE	RTOE	RENDE	RCRCE	RDIRE	RINDE
15	14	13	12	11	10	9	8
–	–	–	–	–	–	SDIOIRQB	SDIOIRQA
7	6	5	4	3	2	1	0
–	–	NOTBUSY	DTIP	BLKE	TXRDY	RXRDY	CMDRDY

- **CMDRDY:** Command Ready Interrupt Enable
- **RXRDY:** Receiver Ready Interrupt Enable
- **TXRDY:** Transmit Ready Interrupt Enable
- **BLKE:** Data Block Ended Interrupt Enable
- **DTIP:** Data Transfer in Progress Interrupt Enable
- **NOTBUSY:** Data Not Busy Interrupt Enable
- **SDIOIRQA:** SDIO Interrupt for Slot A Interrupt Enable
- **SDIOIRQB:** SDIO Interrupt for Slot B Interrupt Enable
- **RINDE:** Response Index Error Interrupt Enable
- **RDIRE:** Response Direction Error Interrupt Enable
- **RCRCE:** Response CRC Error Interrupt Enable
- **RENDE:** Response End Bit Error Interrupt Enable
- **RTOE:** Response Time-out Error Interrupt Enable
- **DCRCE:** Data CRC Error Interrupt Enable
- **DTOE:** Data Time-out Error Interrupt Enable
- **OVRE:** Overrun Interrupt Enable
- **UNRE:** UnderRun Interrupt Enable

0 = No effect.

1 = Enables the corresponding interrupt.

31.10.13 MCI Interrupt Disable Register

Name: IDR

Access Type: Write-only

31	30	29	28	27	26	25	24
UNRE	OVRE	–	–	–	–	–	–
23	22	21	20	19	18	17	16
–	DTOE	DCRCE	RTOE	RENDE	RCRCE	RDIRE	RINDE
15	14	13	12	11	10	9	8
–	–	–	–	–	–	SDIOIRQB	SDIOIRQA
7	6	5	4	3	2	1	0
–	–	NOTBUSY	DTIP	BLKE	TXRDY	RXRDY	CMDRDY

- **CMDRDY:** Command Ready Interrupt Disable
- **RXRDY:** Receiver Ready Interrupt Disable
- **TXRDY:** Transmit Ready Interrupt Disable
- **BLKE:** Data Block Ended Interrupt Disable
- **DTIP:** Data Transfer in Progress Interrupt Disable
- **NOTBUSY:** Data Not Busy Interrupt Disable
- **SDIOIRQA:** SDIO Interrupt for Slot A Interrupt Enable
- **SDIOIRQB:** SDIO Interrupt for Slot B Interrupt Enable
- **RINDE:** Response Index Error Interrupt Disable
- **RDIRE:** Response Direction Error Interrupt Disable
- **RCRCE:** Response CRC Error Interrupt Disable
- **RENDE:** Response End Bit Error Interrupt Disable
- **RTOE:** Response Time-out Error Interrupt Disable
- **DCRCE:** Data CRC Error Interrupt Disable
- **DTOE:** Data Time-out Error Interrupt Disable
- **OVRE:** Overrun Interrupt Disable
- **UNRE:** UnderRun Interrupt Disable

0 = No effect.

1 = Disables the corresponding interrupt.

31.10.14 MCI Interrupt Mask Register

Name: IMR

Access Type: Read-only

31	30	29	28	27	26	25	24
UNRE	OVRE	–	–	–	–	–	–
23	22	21	20	19	18	17	16
–	DTOE	DCRCE	RTOE	RENDE	RCRCE	RDIRE	RINDE
15	14	13	12	11	10	9	8
–	–	–	–	–	–	SDIOIRQB	SDIOIRQA
7	6	5	4	3	2	1	0
–	–	NOTBUSY	DTIP	BLKE	TXRDY	RXRDY	CMDRDY

- **CMDRDY:** Command Ready Interrupt Mask
- **RXRDY:** Receiver Ready Interrupt Mask
- **TXRDY:** Transmit Ready Interrupt Mask
- **BLKE:** Data Block Ended Interrupt Mask
- **DTIP:** Data Transfer in Progress Interrupt Mask
- **NOTBUSY:** Data Not Busy Interrupt Mask
- **SDIOIRQA:** SDIO Interrupt for Slot A Interrupt Enable
- **SDIOIRQB:** SDIO Interrupt for Slot B Interrupt Enable
- **RINDE:** Response Index Error Interrupt Mask
- **RDIRE:** Response Direction Error Interrupt Mask
- **RCRCE:** Response CRC Error Interrupt Mask
- **RENDE:** Response End Bit Error Interrupt Mask
- **RTOE:** Response Time-out Error Interrupt Mask
- **DCRCE:** Data CRC Error Interrupt Mask
- **DTOE:** Data Time-out Error Interrupt Mask
- **OVRE:** Overrun Interrupt Mask
- **UNRE:** UnderRun Interrupt Mask

0 = The corresponding interrupt is not enabled.

1 = The corresponding interrupt is enabled.

32. USB Device - High Speed (480 Mbits/s)

Rev: 1.4.0.0

32.1 Features

- **USB v2.0 High Speed Compliant, 480 Mbits Per Second**
- **UTMI Compliant**
- **7 Endpoints**
- **Embedded Dual-port RAM for Endpoints**
- **Suspend/Resume Logic (Command of UTMI)**
- **Up to Three Memory Banks for Endpoints (Not for Control Endpoint)**
- **4 KBytes of DPRAM**
- **Compatible with Embedded ARM9TDMI® Processor**

32.2 Description

The USB High Speed Device (USBA) is compliant with the Universal Serial Bus (USB), rev 2.0 High Speed device specification.

Each endpoint can be configured in one of several USB transfer types. It can be associated with one, two or three banks of a dual-port RAM used to store the current data payload. If two or three banks are used, one DPR bank is read or written by the processor, while the other is read or written by the USB device peripheral. This feature is mandatory for isochronous endpoints.

Table 32-1. USBA Endpoint Description

Endpoint #	Mnemonic	Nb Bank	DMA	High Band Width	Max. Endpoint Size	Endpoint Type
0	EP0	1	N	N	64	Control
1	EP1	2	Y	Y	512	Ctrl/Bulk/Iso/Interrupt
2	EP2	2	Y	Y	512	Ctrl/Bulk/Iso/Interrupt
3	EP3	3	Y	N	64	Ctrl/Bulk/Interrupt
4	EP4	3	Y	N	64	Ctrl/Bulk/Interrupt
5	EP5	3	Y	Y	1024	Ctrl/Bulk/Interrupt
6	EP6	3	Y	Y	1024	Ctrl/Bulk/Interrupt

The default size of the DPRAM is 4 KB.

Suspend and resume are automatically detected by the USBA device, which notifies the processor by raising an interrupt.

32.3 Block Diagram

Figure 32-1. Block diagram:

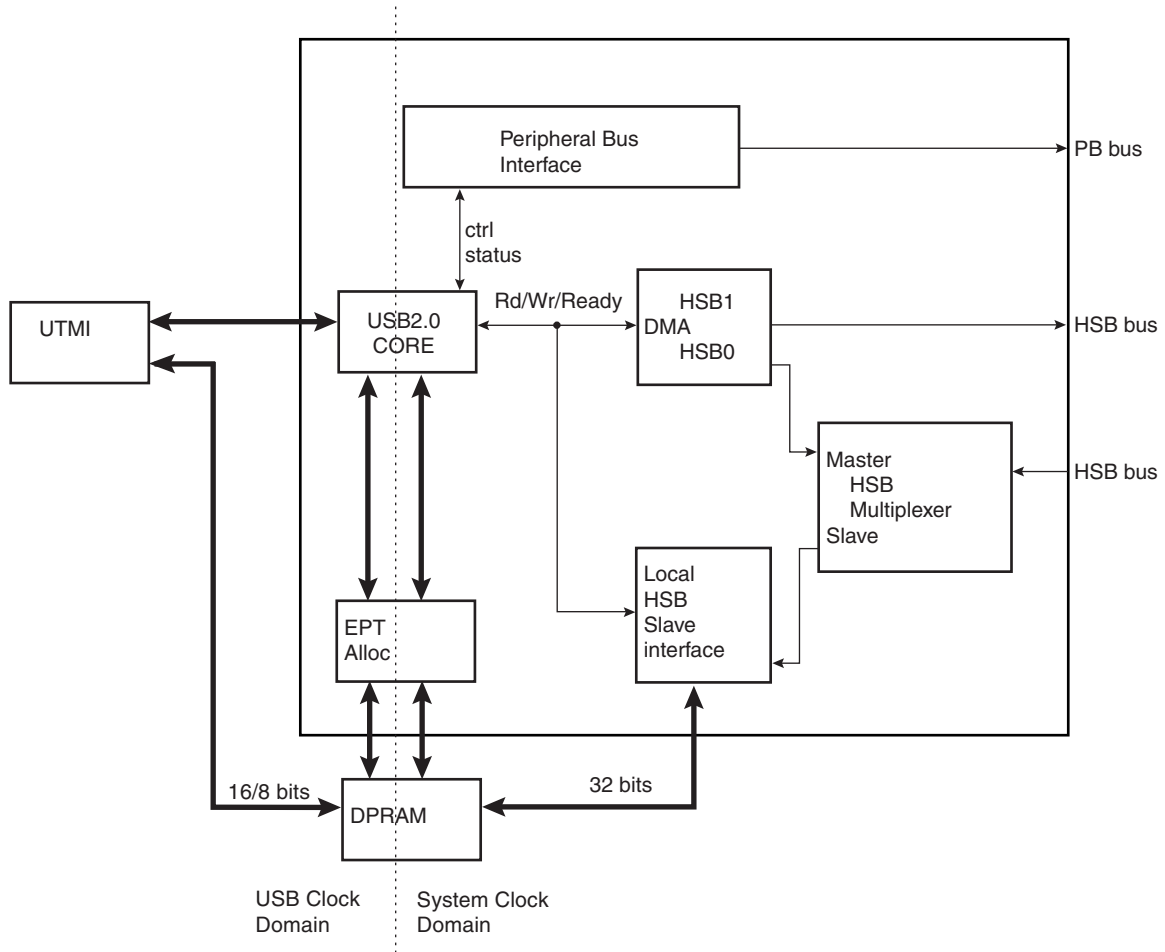

32.4 Typical Connection

Figure 32-2. Board Schematic

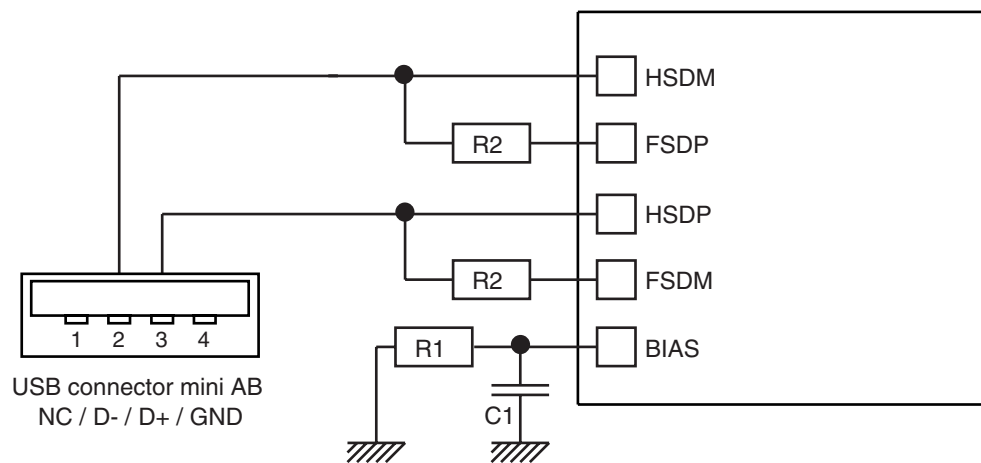

Table 32-2. Components Typical Values

Symbol	Value ⁽¹⁾	Unit
R1	$6.8 \pm 1\%$	k Ω
R2	$39 \pm 1\%$	Ω
C1	10	pF

Note: 1. Values are guidelines only. Actual values are TBD.

32.5 USB V2.0 High Speed Device Introduction

The USB V2.0 High Speed Device provides communication services to/from host when attached. Each device is offered with a collection of communication flows (pipes) associated with each endpoint. Software on the host communicates with a USB Device through a set of communication flows.

32.5.1 USB V2.0 High Speed Transfer Types

A communication flow is carried over one of four transfer types defined by the USB device.

A device provides several logical communication pipes with the host. To each logical pipe is associated an endpoint. Transfer through a pipe belongs to one of the four transfer types:

- **Control Transfers:** Used to configure a device at attach time and can be used for other device-specific purposes, including control of other pipes on the device.
- **Bulk Data Transfers:** Generated or consumed in relatively large burst quantities and have wide dynamic latitude in transmission constraints.
- **Interrupt Data Transfers:** Used for timely but reliable delivery of data, for example, characters or coordinates with human-perceptible echo or feedback response characteristics.
- **Isochronous Data Transfers:** Occupy a prenegotiated amount of USB bandwidth with a prenegotiated delivery latency. (Also called streaming real time transfers.)

As indicated below, transfers are sequential events carried out on the USB bus.

Endpoints must be configured according to the transfer type they handle.

Table 32-3. USB Communication Flow

Transfer	Direction	Bandwidth	Endpoint Size	Error Detection	Retrying
Control	Bidirectional	Not guaranteed	8,16,32,64	Yes	Automatic
Isochronous	Unidirectional	Guaranteed	8-1024	Yes	No
Interrupt	Unidirectional	Not guaranteed	8-1024	Yes	Yes
Bulk	Unidirectional	Not guaranteed	8-512	Yes	Yes

32.5.2 USB Transfer Event Definitions

A transfer is composed of one or several transactions;

Table 32-4. USB Transfer Events

CONTROL (bidirectional)	Control Transfers ⁽¹⁾	<ul style="list-style-type: none"> • Setup transaction > Data IN transactions > Status OUT transaction • Setup transaction > Data OUT transactions > Status IN transaction • Setup transaction > Status IN transaction
IN (device toward host)	Bulk IN Transfer	• Data IN transaction > Data IN transaction
	Interrupt IN Transfer	• Data IN transaction > Data IN transaction
	Isochronous IN Transfer ⁽²⁾	• Data IN transaction > Data IN transaction
OUT (host toward device)	Bulk OUT Transfer	• Data OUT transaction > Data OUT transaction
	Interrupt OUT Transfer	• Data OUT transaction > Data OUT transaction
	Isochronous OUT Transfer ⁽²⁾	• Data OUT transaction > Data OUT transaction

Notes: 1. Control transfer must use endpoints with one bank and can be aborted using a stall handshake.
2. Isochronous transfers must use endpoints configured with two or three banks.

An endpoint handles all transactions related to the type of transfer for which it has been configured.

32.5.3 USB V2.0 High Speed BUS Transactions

Each transfer results in one or more transactions over the USB bus.

There are five kinds of transactions flowing across the bus in packets:

1. Setup Transaction
2. Data IN Transaction
3. Data OUT Transaction
4. Status IN Transaction
5. Status OUT Transaction

Figure 32-3. Control Read and Write Sequences

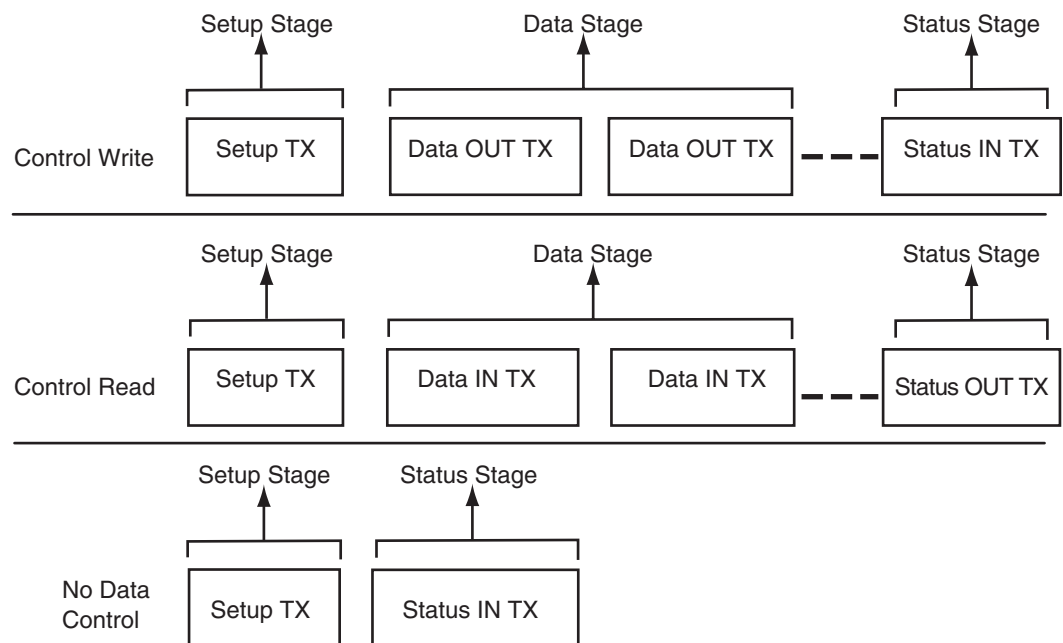

A status IN or OUT transaction is identical to a data IN or OUT transaction.

32.5.4 Endpoint Configuration

The endpoint 0 is always a control endpoint, it must be programmed and active in order to be enabled when the End Of Reset interrupt occurs.

To configure the endpoints:

- Fill the configuration register (EPTCFG) with the endpoint size, direction (IN or OUT), type (CTRL, Bulk, IT, ISO) and the number of banks.
- Fill the number of transactions (NB_TRANS) for isochronous endpoints.

Note: For control endpoints the direction has no effect.

- Verify that the EPT_MAPD flag is set. This flag is set if the endpoint size and the number of banks are correct compared to the FIFO maximum capacity and the maximum number of allowed banks.
- Configure control flags of the endpoint and enable it in EPTCTLENBx according to ["USBA Endpoint Control Register"](#) on page 649.

Control endpoints can generate interrupts and use only 1 bank.

All endpoints (except endpoint 0) can be configured either as Bulk, Interrupt or Isochronous. See [Table 32-1. USBA Endpoint Description](#).

The maximum packet size they can accept corresponds to the maximum endpoint size.

Note: The endpoint size of 1024 is reserved for isochronous endpoints.

The size of the DPRAM is 4 KB. The DPR is shared by all active endpoints. The memory size required by the active endpoints must not exceed the size of the DPRAM.

$SIZE_DPRAM = SIZE_EPT0$
 $+ NB_BANK_EPT1 \times SIZE_EPT1$
 $+ NB_BANK_EPT2 \times SIZE_EPT2$
 $+ NB_BANK_EPT3 \times SIZE_EPT3$
 $+ NB_BANK_EPT4 \times SIZE_EPT4$
 $+ NB_BANK_EPT5 \times SIZE_EPT5$
 $+ NB_BANK_EPT6 \times SIZE_EPT6$
 +... (refer to [32.6.17 USBA Endpoint Configuration Register](#))

If a user tries to configure endpoints with a size the sum of which is greater than the DPRAM, then the EPT_MAPD is not set.

The application has access to the physical block of DPR reserved for the endpoint through a 64 KB logical address space.

The physical block of DPR allocated for the endpoint is remapped all along the 64 KB logical address space. The application can write a 64 KB buffer linearly.

Figure 32-4. Logical Address Space for DPR Access:

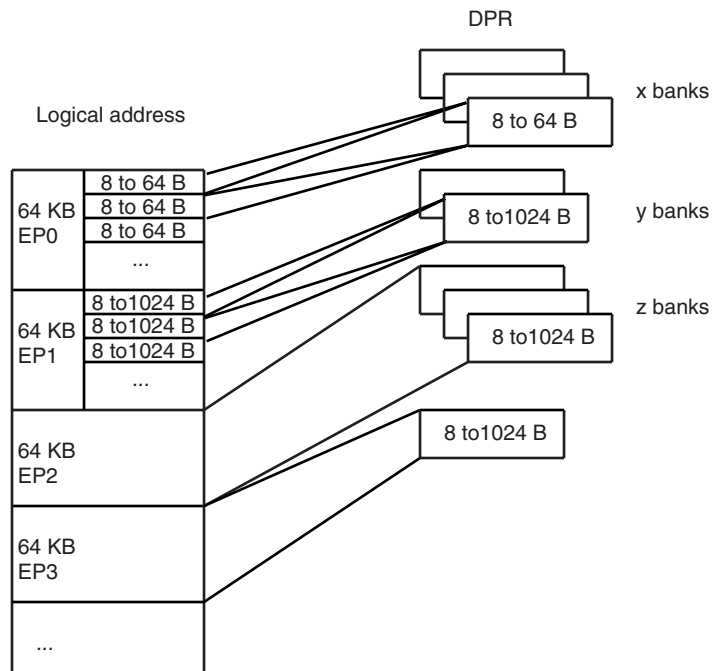

Configuration examples of EPTCTLx ([USBA Endpoint Control Register](#)) for Bulk IN endpoint type follow below.

- With DMA
 - AUTO_VALID: Automatically validate the packet and switch to the next bank.
 - EPT_ENABL: Enable endpoint.
- Without DMA:
 - TX_BK_RDY: An interrupt is generated after each transmission.
 - EPT_ENABL: Enable endpoint.

Configuration examples of Bulk OUT endpoint type follow below.

- With DMA
 - AUTO_VALID: Automatically validate the packet and switch to the next bank.
 - EPT_ENABL: Enable endpoint.
- Without DMA
 - RX_BK_RDY: An interrupt is sent after a new packet has been stored in the endpoint FIFO.
 - EPT_ENABL: Enable endpoint.

32.5.5 DMA

USB packets of any length may be transferred when required by the USBA Device. These transfers always feature sequential addressing.

Packet data HSB bursts may be locked on a DMA buffer basis for drastic overall HSB bus bandwidth performance boost with paged memories. These clock-cycle consuming memory row (or bank) changes will then likely not occur, or occur only once instead of dozens times, during a single big USB packet DMA transfer in case another HSB master addresses the memory. This means up to 128-word single-cycle unbroken HSB bursts for Bulk endpoints and 256-word single-cycle unbroken bursts for isochronous endpoints. This maximum burst length is then controlled by the lowest programmed USB endpoint size (EPT_SIZE bit in the EPTCFGx register) and DMA Size (BUFF_LENGTH bit in the DMACONTROLx register).

The USBA device average throughput may be up to nearly 60 MBytes. Its internal slave average access latency decreases as burst length increases due to the 0 wait-state side effect of unchanged endpoints. If at least 0 wait-state word burst capability is also provided by the external DMA HSB bus slaves, each of both DMA HSB busses need less than 50% bandwidth allocation for full USBA bandwidth usage at 30 MHz, and less than 25% at 60 MHz.

The USBA DMA Channel Transfer Descriptor is described in ["USBA DMA Channel Transfer Descriptor" on page 660](#)

Figure 32-5. Example of DMA Chained List:

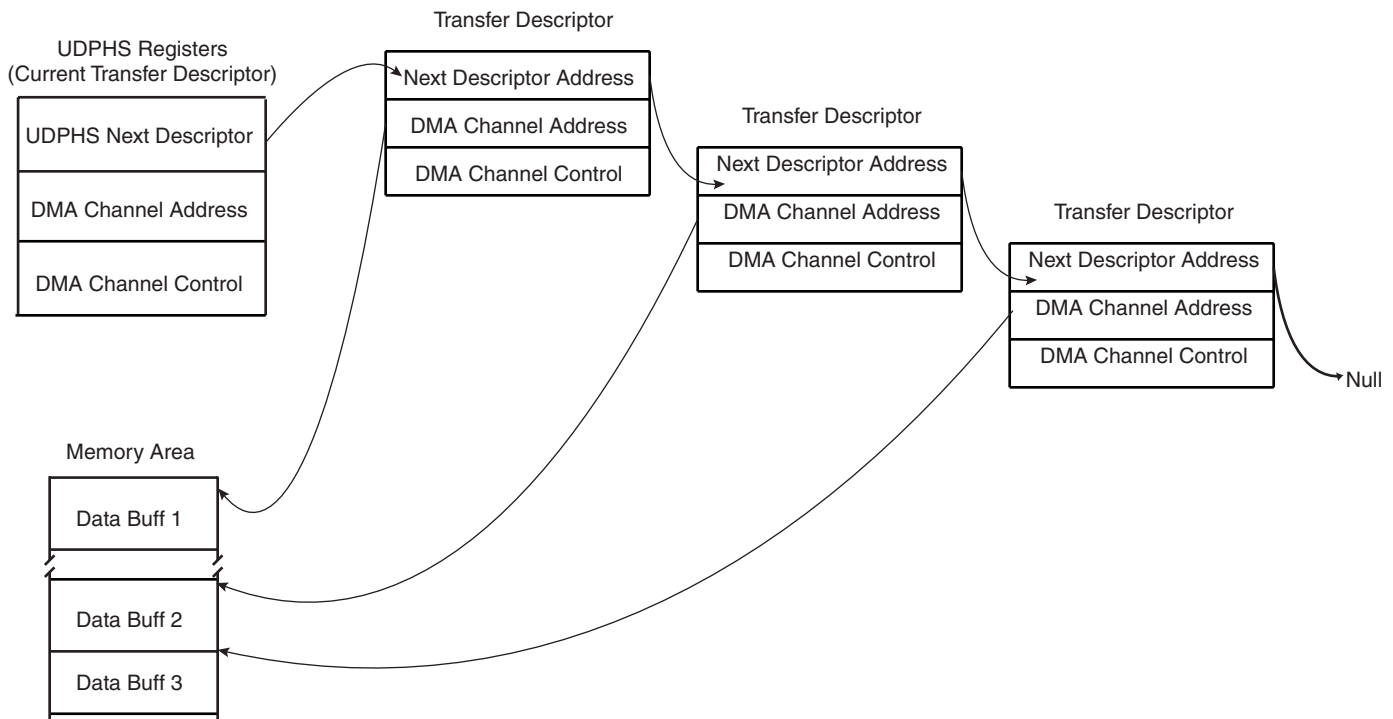

32.5.6 Handling Transactions with USB V2.0 Device Peripheral

32.5.6.1 Setup Transaction

The setup packet is valid in the DPR while RX_SETUP is set. Once RX_SETUP is cleared by the application, the USBA accepts the next packets sent over the device endpoint.

When a valid setup packet is accepted by the USBA:

- the USBA device automatically acknowledges the setup packet (sends an ACK response)
- payload data is written in the endpoint
- sets the RX_SETUP interrupt
- the BYTE_COUNT field in the EPTSTAx register is updated

An endpoint interrupt is generated while RX_SETUP in the EPTSTAx register is not cleared. This interrupt is carried out to the microcontroller if interrupts are enabled for this endpoint.

Thus, firmware must detect RX_SETUP polling EPTSTAx or catching an interrupt, read the setup packet in the FIFO, then clear the RX_SETUP bit in the EPTCLRSTA register to acknowledge the setup stage.

If STALL_SNT was set to 1, then this bit is automatically reset when a setup token is detected by the device. Then, the device still accepts the setup stage. (See [Section 32.5.6.15 "STALL" on page 613](#)).

32.5.6.2 NYET

NYET is a High Speed only handshake. It is returned by a High Speed endpoint as part of the PING protocol.

High Speed devices must support an improved NAK mechanism for Bulk OUT and control endpoints (except setup stage). This mechanism allows the device to tell the host whether it has sufficient endpoint space for the next OUT transfer (see USB 2.0 spec 8.5.1 NAK Limiting via Ping Flow Control).

The NYET/ACK response to a High Speed Bulk OUT transfer and the PING response are automatically handled by hardware in the EPTCTLx register (except when the user wants to force a NAK response by using the NYET_DIS bit).

If the endpoint responds instead to the OUT/DATA transaction with an NYET handshake, this means that the endpoint accepted the data but does not have room for another data payload. The host controller must return to using a PING token until the endpoint indicates it has space available.

Figure 32-6. NYET Example with Two Endpoint Banks

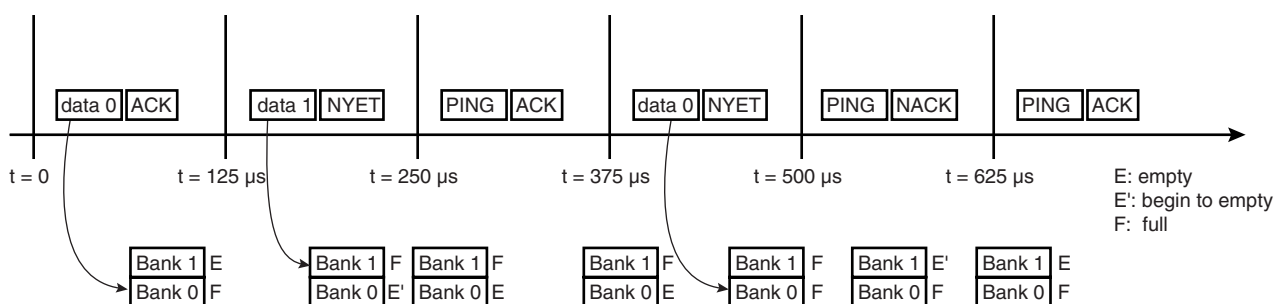

32.5.6.3 Data IN

32.5.6.4 Bulk IN or Interrupt IN

Data IN packets are sent by the device during the data or the status stage of a control transfer or during an (interrupt/bulk/isochronous) IN transfer. Data buffers are sent packet by packet under the control of the application or under the control of the DMA channel.

There are three ways for an application to transfer a buffer in several packets over the USB:

- packet by packet (see 32.5.6.5 below)
- 64 KB (see 32.5.6.5 below)
- DMA (see 32.5.6.6 below)

32.5.6.5 Bulk IN or Interrupt IN: Sending a Packet Under Application Control (Device to Host)

The application can write one or several banks.

A simple algorithm can be used by the application to send packets regardless of the number of banks associated to the endpoint.

Algorithm Description for Each Packet:

- The application waits for TX_PK_RDY flag to be cleared in the EPTSTAx register before it can perform a write access to the DPR.
- The application writes one USB packet of data in the DPR through the 64 KB endpoint logical memory window.
- The application sets TX_PK_RDY flag in the EPTSETSTAx register.

The application is notified that it is possible to write a new packet to the DPR by the TX_PK_RDY interrupt. This interrupt can be enabled or masked by setting the TX_PK_RDY bit in the EPTCTLENB/EPTCTLDIS register.

Algorithm Description to Fill Several Packets:

Using the previous algorithm, the application is interrupted for each packet. It is possible to reduce the application overhead by writing linearly several banks at the same time. The AUTO_VALID bit in the EPTCTLx must be set by writing the AUTO_VALID bit in the EPTCTLENBx register.

The auto-valid-bank mechanism allows the transfer of data (IN and OUT) without the intervention of the CPU. This means that bank validation (set TX_PK_RDY or clear the RX_BK_RDY bit) is done by hardware.

- The application checks the BUSY_BANK_STA field in the EPTSTAx register. The application must wait that at least one bank is free.
- The application writes a number of bytes inferior to the number of free DPR banks for the endpoint. Each time the application writes the last byte of a bank, the TX_PK_RDY signal is automatically set by the USBA.
- If the last packet is incomplete (i.e., the last byte of the bank has not been written) the application must set the TX_PK_RDY bit in the EPTSETSTAx register.

The application is notified that all banks are free, so that it is possible to write another burst of packets by the BUSY_BANK interrupt. This interrupt can be enabled or masked by setting the BUSY_BANK flag in the EPTCTLENB and EPTCTLDIS registers.

This algorithm must not be used for isochronous transfer. In this case, the ping-pong mechanism does not operate.

A Zero Length Packet can be sent by setting just the TX_PKTRDY flag in the EPTSETSTAx register.

32.5.6.6 Bulk IN or Interrupt IN: Sending a Buffer Using DMA (Device to Host)

The USB A integrates a DMA host controller. This DMA controller can be used to transfer a buffer from the memory to the DPR or from the DPR to the processor memory under the USB A control. The DMA can be used for all transfer types except control transfer.

Example DMA configuration:

1. Program DMAADDRESSx with the address of the buffer that should be transfer.
2. Enable the interrupt of the DMA in IEN
3. Program DMACONTROLx:
 - Size of buffer to send: size of the buffer to be sent to the host.
 - END_B_EN: The endpoint can validate the packet (according to the values programmed in the AUTO_VALID and SHRT_PCKT fields of EPTCTLx.) (See ["USBA Endpoint Control Register" on page 649](#) and [Figure 32-11. Autovalid with DMA](#))
 - END_BUFFIT: generate an interrupt when the BUFF_COUNT in DMASTATUSx reaches 0.
 - CHANN_ENB: Run and stop at end of buffer

The auto-valid-bank mechanism allows the transfer of data (IN & OUT) without the intervention of the CPU. This means that bank validation (set TX_PK_RDY or clear the RX_BK_RDY bit) is done by hardware.

A transfer descriptor can be used. Instead of programming the register directly, a descriptor should be programmed and the address of this descriptor is then given to DMANXTDSC to be processed after setting the LDNXT_DSC field (Load Next Descriptor Now) in DMACONTROLx register.

The structure that defines this transfer descriptor must be aligned.

Each buffer to be transferred must be described by a DMA Transfer descriptor (see ["USBA DMA Channel Transfer Descriptor" on page 660](#)). Transfer descriptors are chained. Before executing transfer of the buffer, the USB A may fetch a new transfer descriptor from the memory address pointed by the DMANXTDSCx register. Once the transfer is complete, the transfer status is updated in the DMASTATUSx register.

To chain a new transfer descriptor with the current DMA transfer, the DMA channel must be stopped. To do so, INTDIS_DMA and TX_BK_RDY may be set in the EPTCTLENBx register. It is also possible for the application to wait for the completion of all transfers. In this case the LDNXT_DSC field in the last transfer descriptor DMACONTROLx register must be set to 0 and CHANN_ENB set to 1.

Then the application can chain a new transfer descriptor.

The INTDIS_DMA can be used to stop the current DMA transfer if an enabled interrupt is triggered. This can be used to stop DMA transfers in case of errors.

The application can be notified at the end of any buffer transfer (ENB_BUFFIT bit in the DMA-CONTROLx register).

Figure 32-7. Data IN Transfer for Endpoint with One Bank

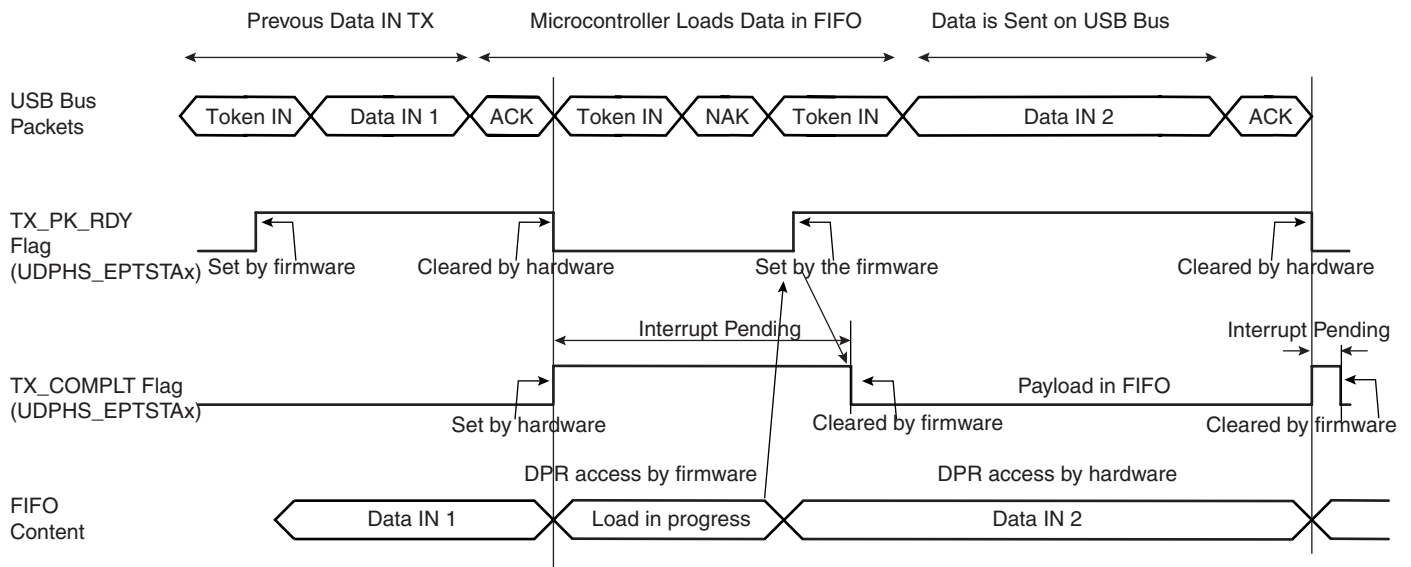

Figure 32-8. Data IN Transfer for Endpoint with Two Banks

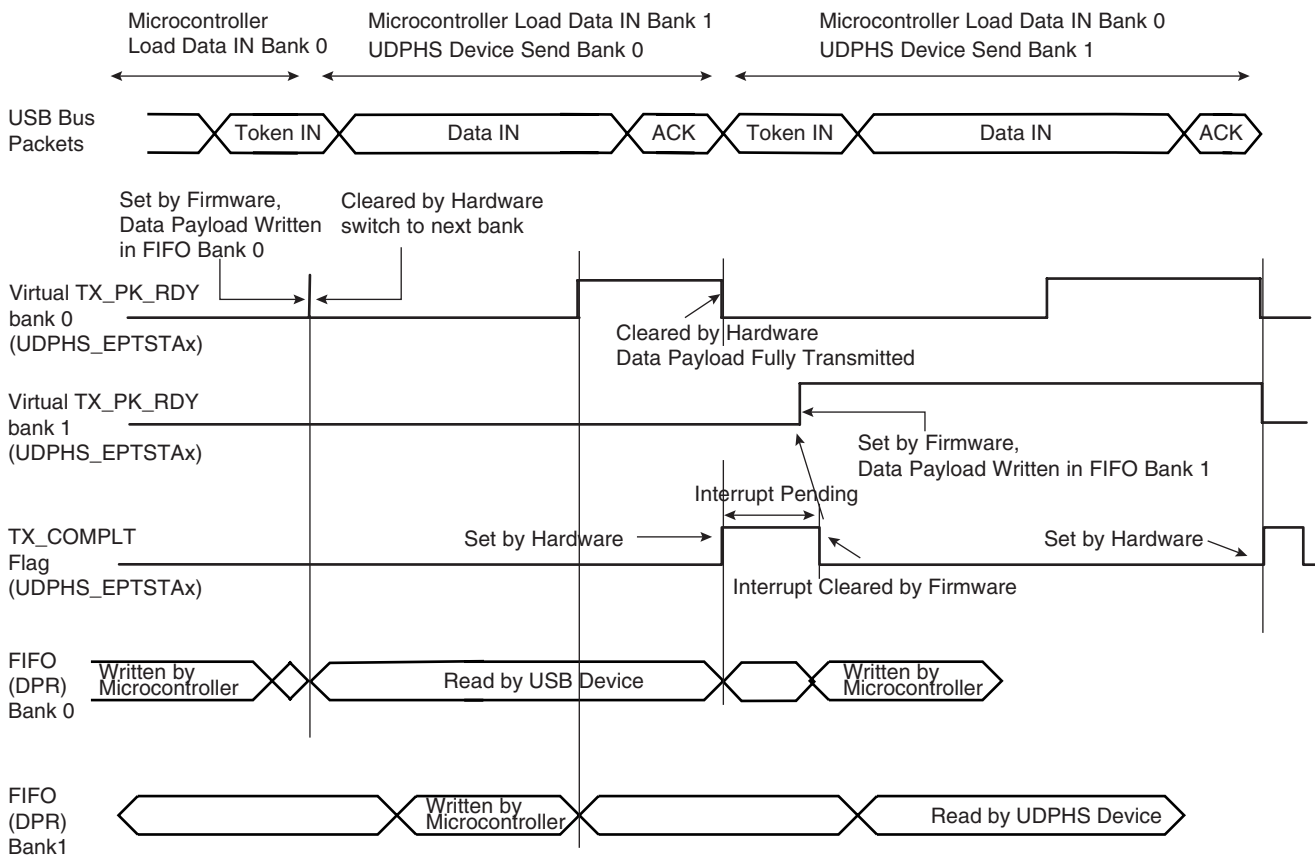
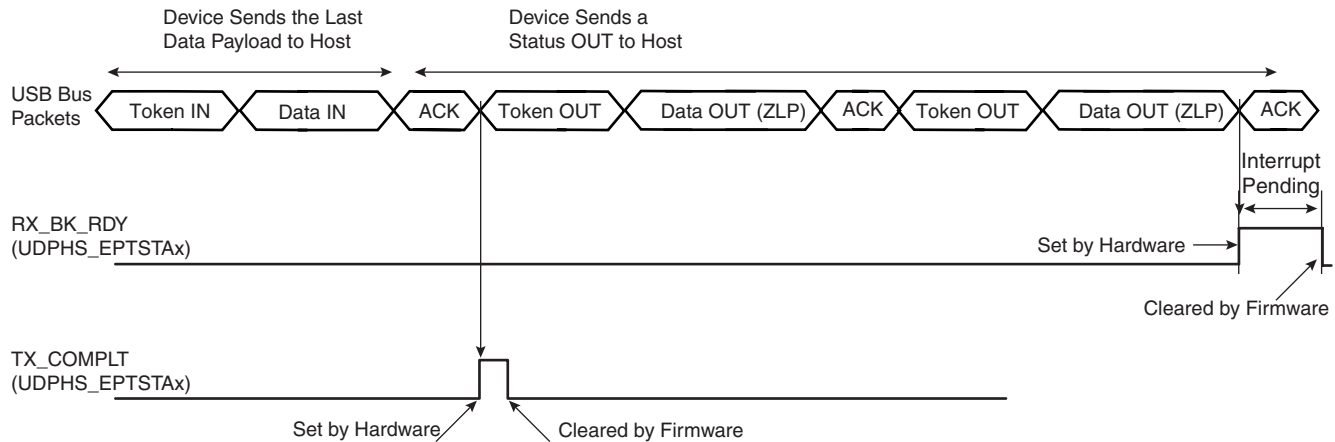
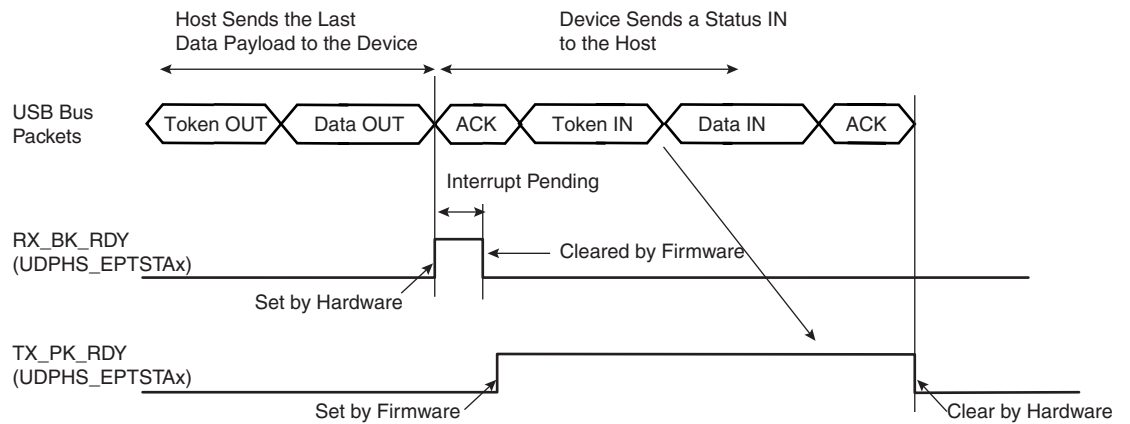

Figure 32-9. Data IN Followed By Status OUT Transfer at the End of a Control Transfer



Note: A NAK handshake is always generated at the first status stage token.

Figure 32-10. Data OUT Followed by Status IN Transfer



Note: Before proceeding to the status stage, the software should determine that there is no risk of extra data from the host (data stage). If not certain (non-predictable data stage length), then the software should wait for a NAK-IN interrupt before proceeding to the status stage. This precaution should be taken to avoid collision in the FIFO.

Figure 32-11. Autovalid with DMA

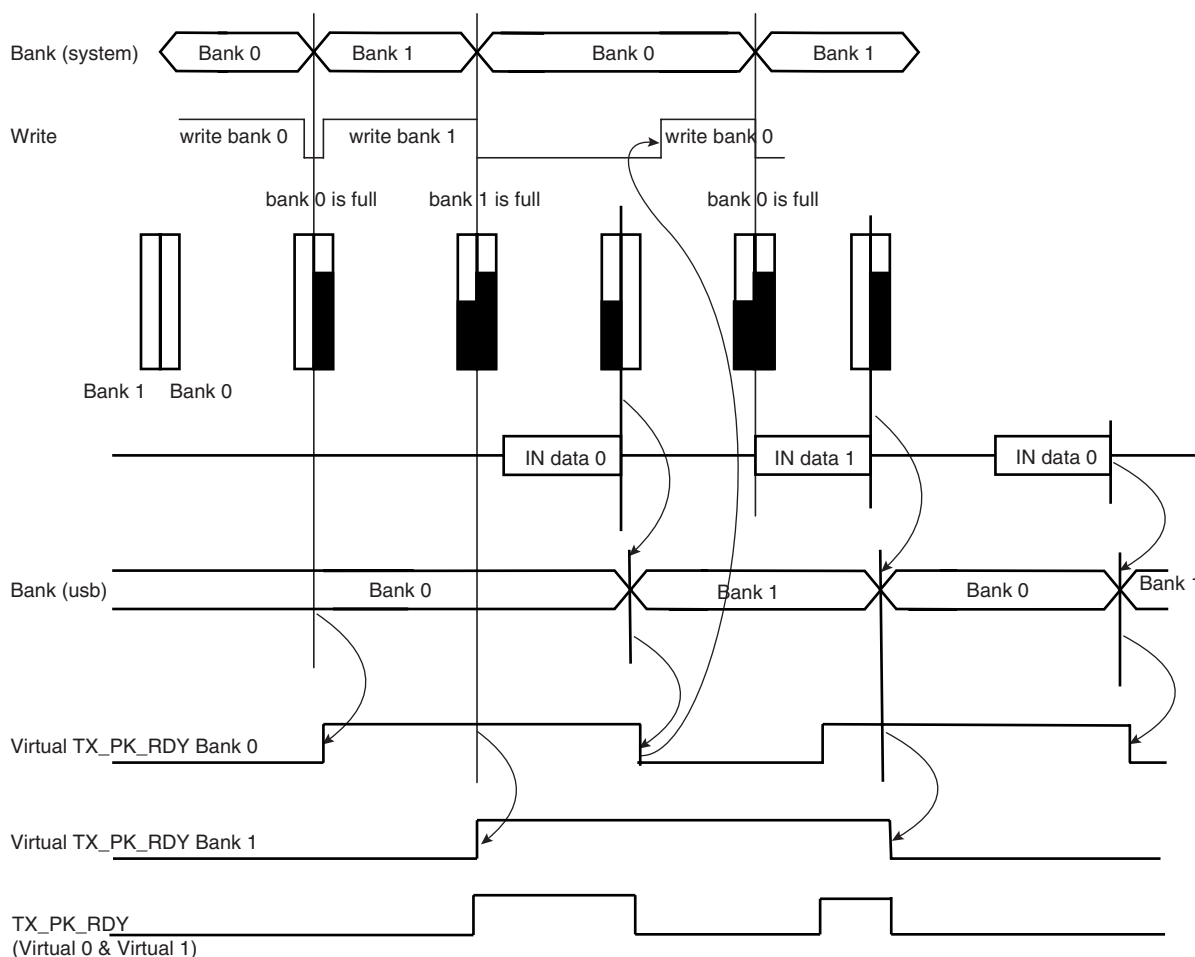

Note: In the illustration above Autovalid validates a bank as full, although this might not be the case, in order to continue processing data and to send to DMA.

32.5.6.7 Isochronous IN

Isochronous-IN is used to transmit a stream of data whose timing is implied by the delivery rate. Isochronous transfer provides periodic, continuous communication between host and device.

It guarantees bandwidth and low latencies appropriate for telephony, audio, video, etc.

If the endpoint is not available (TX_PK_RDY = 0), then the device does not answer to the host. An ERR_FL_ISO interrupt is generated in the EPTSTAx register and once enabled, then sent to the CPU.

The STALL_SNT command bit is not used for an ISO-IN endpoint.

32.5.6.8 High Bandwidth Isochronous Endpoint Handling: IN Example

For high bandwidth isochronous endpoints, the DMA can be programmed with the number of transactions (BUFF_LENGTH field in DMACONTROLx) and the system should provide the required number of packets per microframe, otherwise, the host will notice a sequencing problem.

A response should be made to the first token IN recognized inside a microframe under the following conditions:

- If at least one bank has been validated, the correct DATAx corresponding to the programmed Number Of Transactions per Microframe (NB_TRANS) should be answered. In case of a subsequent missed or corrupted token IN inside the microframe, the USB Core available data bank(s) that should normally have been transmitted during that microframe shall be flushed at its end. If this flush occurs, an error condition is flagged (ERR_FLUSH is set in EPTSTAx).
- If no bank is validated yet, the default DATA0 ZLP is answered and underflow is flagged (ERR_FL_ISO is set in EPTSTAx). Then, no data bank is flushed at microframe end.
- If no data bank has been validated at the time when a response should be made for the second transaction of NB_TRANS = 3 transactions microframe, a DATA1 ZLP is answered and underflow is flagged (ERR_FL_ISO is set in EPTSTAx). If and only if remaining untransmitted banks for that microframe are available at its end, they are flushed and an error condition is flagged (ERR_FLUSH is set in EPTSTAx).
- If no data bank has been validated at the time when a response should be made for the last programmed transaction of a microframe, a DATA0 ZLP is answered and underflow is flagged (ERR_FL_ISO is set in EPTSTAx). If and only if the remaining untransmitted data bank for that microframe is available at its end, it is flushed and an error condition is flagged (ERR_FLUSH is set in EPTSTAx).
- If at the end of a microframe no valid token IN has been recognized, no data bank is flushed and no error condition is reported.

At the end of a microframe in which at least one data bank has been transmitted, if less than NB_TRANS banks have been validated for that microframe, an error condition is flagged (ERR_TRANS is set in EPTSTAx).

Cases of Error (in EPTSTAx)

- ERR_FL_ISO: There was no data to transmit inside a microframe, so a ZLP is answered by default.
- ERR_FLUSH: At least one packet has been sent inside the microframe, but the number of token IN received is lesser than the number of transactions actually validated (TX_BK_RDY) and likewise with the NB_TRANS programmed.
- ERR_TRANS: At least one packet has been sent inside the microframe, but the number of token IN received is lesser than the number of programmed NB_TRANS transactions and the packets not requested were not validated.
- ERR_FL_ISO + ERR_FLUSH: At least one packet has been sent inside the microframe, but the data has not been validated in time to answer one of the following token IN.
- ERR_FL_ISO + ERR_TRANS: At least one packet has been sent inside the microframe, but the data has not been validated in time to answer one of the following token IN and the data can be discarded at the microframe end.

- **ERR_FLUSH + ERR_TRANS:** The first token IN has been answered and it was the only one received, a second bank has been validated but not the third, whereas NB_TRANS was waiting for three transactions.
- **ERR_FL_ISO + ERR_FLUSH + ERR_TRANS:** The first token IN has been treated, the data for the second Token IN was not available in time, but the second bank has been validated before the end of the microframe. The third bank has not been validated, but three transactions have been set in NB_TRANS.

32.5.6.9 *Data OUT*

32.5.6.10 *Bulk OUT or Interrupt OUT*

Like data IN, data OUT packets are sent by the host during the data or the status stage of control transfer or during an interrupt/bulk/isochronous OUT transfer. Data buffers are sent packet by packet under the control of the application or under the control of the DMA channel.

32.5.6.11 *Bulk OUT or Interrupt OUT: Receiving a Packet Under Application Control (Host to Device)*

Algorithm Description for Each Packet:

- The application enables an interrupt on RX_BK_RDY.
- When an interrupt on RX_BK_RDY is received, the application knows that EPTSTAx register BYTE_COUNT bytes have been received.
- The application reads the BYTE_COUNT bytes from the endpoint.
- The application clears RX_BK_RDY.

Note: If the application does not know the size of the transfer, it may **not** be a good option to use AUTO_VALID. Because if a zero-length-packet is received, the RX_BK_RDY is automatically cleared by the AUTO_VALID hardware and if the endpoint interrupt is triggered, the software will not find its originating flag when reading the EPTSTAx register.

Algorithm to Fill Several Packets:

- The application enables the interrupts of BUSY_BANK and AUTO_VALID.
- When a BUSY_BANK interrupt is received, the application knows that all banks available for the endpoint have been filled. Thus, the application can read all banks available.

If the application doesn't know the size of the receive buffer, instead of using the BUSY_BANK interrupt, the application must use RX_BK_RDY.

32.5.6.12 *Bulk OUT or Interrupt OUT: Sending a Buffer Using DMA (Host To Device)*

To use the DMA setting, the AUTO_VALID field is mandatory.

See [32.5.6.6 Bulk IN or Interrupt IN: Sending a Buffer Using DMA \(Device to Host\)](#) for more information.

DMA Configuration Example:

1. First program DMAADDRESSx with the address of the buffer that should be transferred.
2. Enable the interrupt of the DMA in IEN
3. Program the DMA Channelx Control Register:
 - Size of buffer to be sent.
 - END_B_EN: Can be used for OUT packet truncation (discarding of unbuffered packet data) at the end of DMA buffer.

- END_BUFFIT: Generate an interrupt when BUFF_COUNT in the DMASTATUSx register reaches 0.
- END_TR_EN: End of transfer enable, the USB device can put an end to the current DMA transfer, in case of a short packet.
- END_TR_IT: End of transfer interrupt enable, an interrupt is sent after the last USB packet has been transferred by the DMA, if the USB transfer ended with a short packet. (Beneficial when the receive size is unknown.)
- CHANN_ENB: Run and stop at end of buffer.

For OUT transfer, the bank will be automatically cleared by hardware when the application has read all the bytes in the bank (the bank is empty).

Note: When a zero-length-packet is received, RX_BK_RDY bit in EPTSTAx is cleared automatically by AUTO_VALID, and the application knows of the end of buffer by the presence of the END_TR_IT.

Note: If the host sends a zero-length packet, and the endpoint is free, then the device sends an ACK. No data is written in the endpoint, the RX_BY_RDY interrupt is generated, and the BYTE_COUNT field in EPTSTAx is null.

Figure 32-12. Data OUT Transfer for Endpoint with One Bank

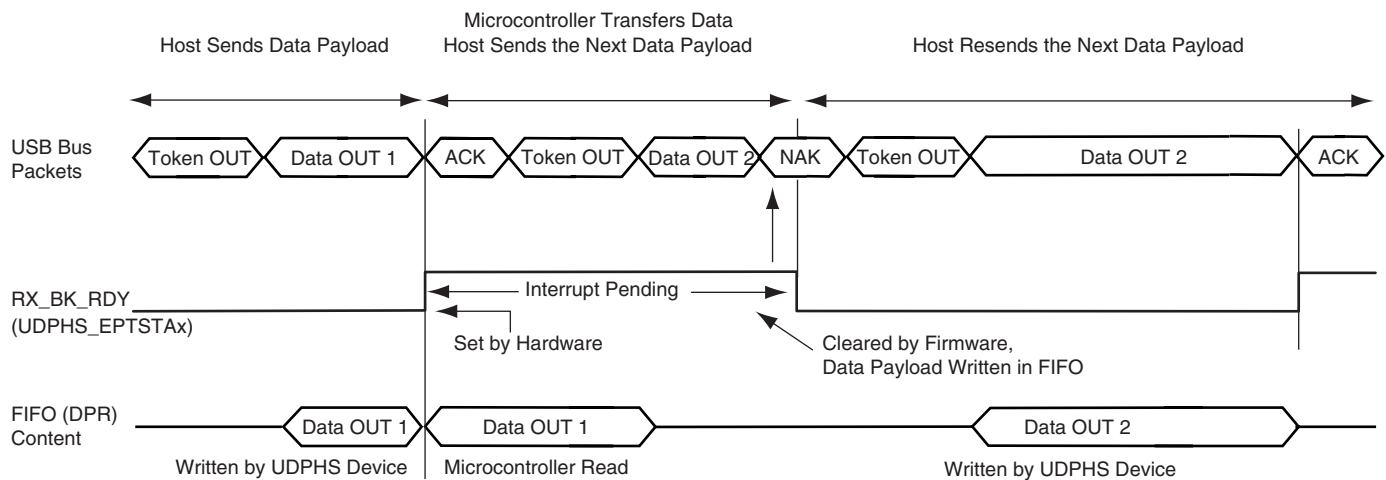
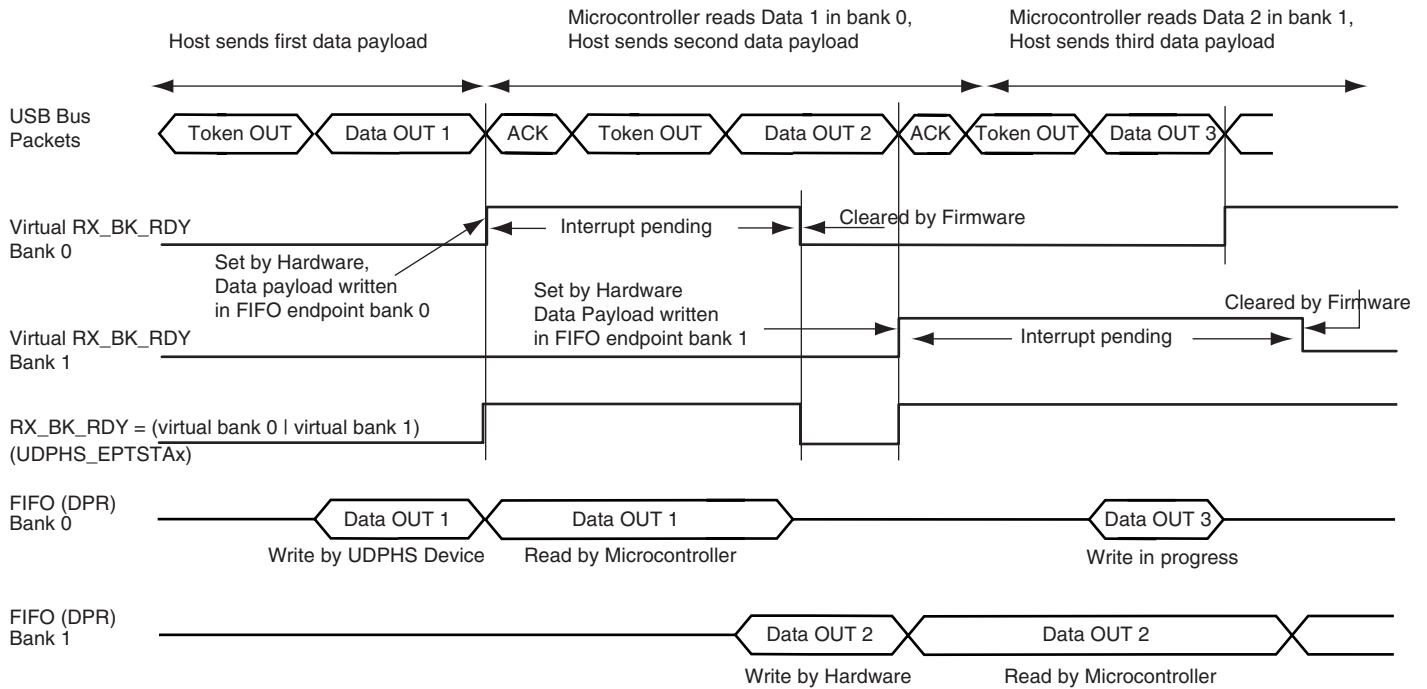
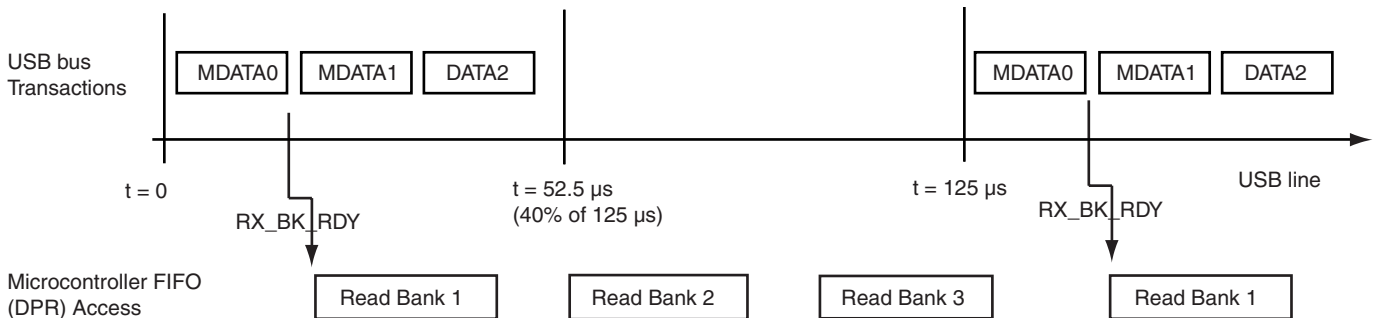

Figure 32-13. Data OUT Transfer for an Endpoint with Two Banks



32.5.6.13 High Bandwidth Isochronous Endpoint OUT

Figure 32-14. Bank Management, Example of Three Transactions per Microframe



USB 2.0 supports individual High Speed isochronous endpoints that require data rates up to 192 Mb/s (24 MB/s): 3x10²⁴ data bytes per microframe.

To support such a rate, two or three banks may be used to buffer the three consecutive data packets. The microcontroller (or the DMA) should be able to empty the banks very rapidly (at least 24 MB/s on average).

NB_TRANS field in EPTCFGx register = Number Of Transactions per Microframe.

If NB_TRANS > 1 then it is High Bandwidth.

Example:

- If NB_TRANS = 3, the sequence should be either
 - MData0
 - MData0/Data1
 - MData0/Data1/Data2
- If NB_TRANS = 2, the sequence should be either
 - MData0
 - MData0/Data1
- If NB_TRANS = 1, the sequence should be
 - Data0

32.5.6.14 Isochronous Endpoint Handling: OUT Example

The user can ascertain the bank status (free or busy), and the toggle sequencing of the data packet for each bank with the EPTSTAx register in the three bit fields as follows:

- TOGGLESQ_STA: PID of the data stored in the current bank
- CURRENT_BANK: Number of the bank currently being accessed by the microcontroller.
- BUSY_BANK_STA: Number of busy bank

This is particularly useful in case of a missing data packet.

If the inter-packet delay between the OUT token and the Data is greater than the USB standard, then the ISO-OUT transaction is ignored. (Payload data is not written, no interrupt is generated to the CPU.)

If there is a data CRC (Cyclic Redundancy Check) error, the payload is, none the less, written in the endpoint. The ERR_CRISO flag is set in EPTSTAx register.

If the endpoint is already full, the packet is not written in the DPRAM. The ERR_FL_ISO flag is set in EPTSTAx.

If the payload data is greater than the maximum size of the endpoint, then the ERR_OVFLW flag is set. It is the task of the CPU to manage this error. The data packet is written in the endpoint (except the extra data).

If the host sends a Zero Length Packet, and the endpoint is free, no data is written in the endpoint, the RX_BK_RDY flag is set, and the BYTE_COUNT field in EPTSTAx register is null.

The FRCESTALL command bit is unused for an isochonous endpoint.

Otherwise, payload data is written in the endpoint, the RX_BK_RDY interrupt is generated and the BYTE_COUNT in EPTSTAx register is updated.

32.5.6.15 STALL

STALL is returned by a function in response to an IN token or after the data phase of an OUT or in response to a PING transaction. STALL indicates that a function is unable to transmit or receive data, or that a control pipe request is not supported.

• OUT

To stall an endpoint, set the FRCESTALL bit in EPTSETSTAx register and after the STALL_SNT flag has been set, set the TOGGLE_SEG bit in the EPTCLRSTAx register.

• IN

Set the FRCESTALL bit in EPTSETSTAx register.

Figure 32-15. Stall Handshake Data OUT Transfer

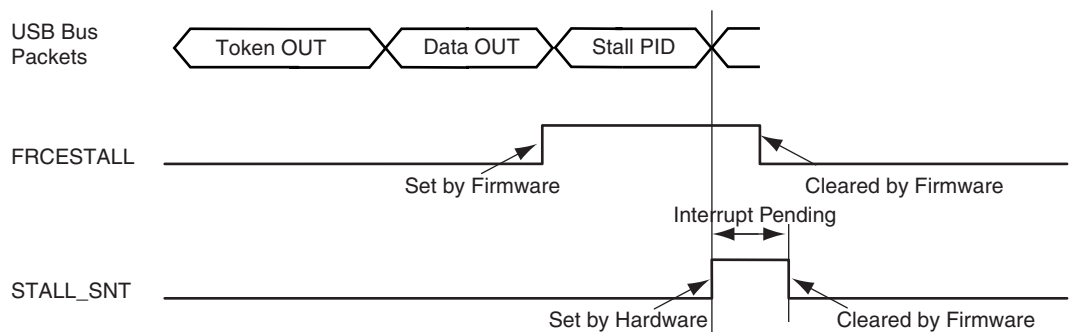
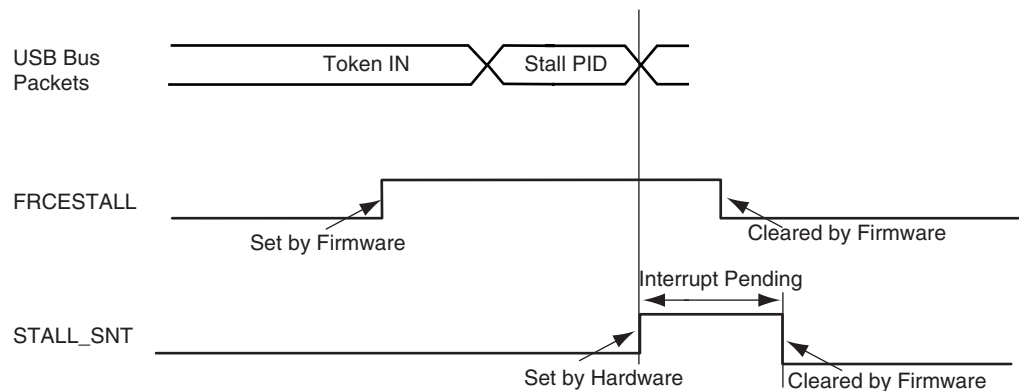

Figure 32-16. Stall Handshake Data IN Transfer



32.5.7 Speed Identification

The high speed reset is managed by the hardware.

At the connection, the host makes a reset which could be a classic reset (full speed) or a high speed reset.

At the end of the reset process (full or high), the ENDRESET interrupt is generated.

Then the CPU should read the SPEED bit in INTSTAx to ascertain the speed mode of the device.

32.5.8 USB V2.0 High Speed Global Interrupt

Interrupts are defined in [Section 32.6.3 "USBA Interrupt Enable Register" \(IEN\)](#) and in [Section 32.6.4 "USBA Interrupt Status Register" \(INTSTA\)](#).

32.5.9 Endpoint Interrupts

Interrupts are enabled in IEN (see [Section 32.6.3 "USBA Interrupt Enable Register"](#)) and individually masked in EPTCTLENBx (see [Section 32.6.18 "USBA Endpoint Control Enable Register"](#)).

Table 32-5. Endpoint Interrupt Source Masks

SHRT_PCKT	Short Packet Interrupt
BUSY_BANK	Busy Bank Interrupt
NAK_OUT	NAKOUT Interrupt
NAK_IN/ERR_FLUSH	NAKIN/Error Flush Interrupt
STALL_SNT/ERR_CRISO/ERR_NB_TRA	Stall Sent/CRC error/Number of Transaction Error Interrupt
RX_SETUP/ERR_FL_ISO	Received SETUP/Error Flow Interrupt
TX_PK_RD /ERR_TRANS	TX Packet Read/Transaction Error Interrupt
TX_COMPLT	Transmitted IN Data Complete Interrupt
RX_BK_RDY	Received OUT Data Interrupt
ERR_OVFLW	Overflow Error Interrupt
MDATA_RX	MDATA Interrupt
DATA_X_RX	DATAx Interrupt

Figure 32-17. USB A Interrupt Control Interface (UDPHS_IEN)

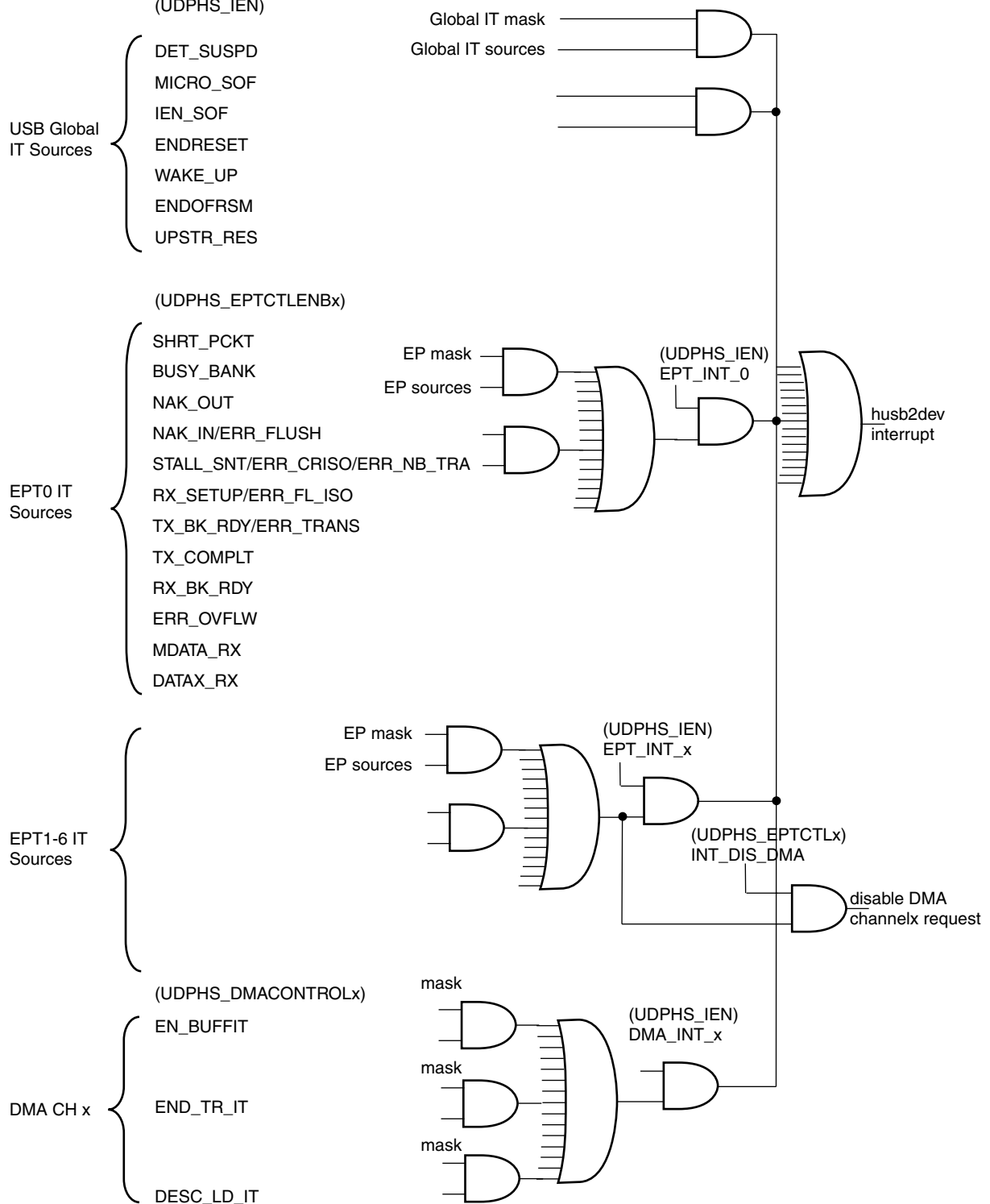

32.5.10 Power Modes

32.5.10.1 Controlling Device States

A USB device has several possible states. Refer to Chapter 9 (USB Device Framework) of the Universal Serial Bus Specification, Rev 2.0.

Figure 32-18. USBADevice State Diagram

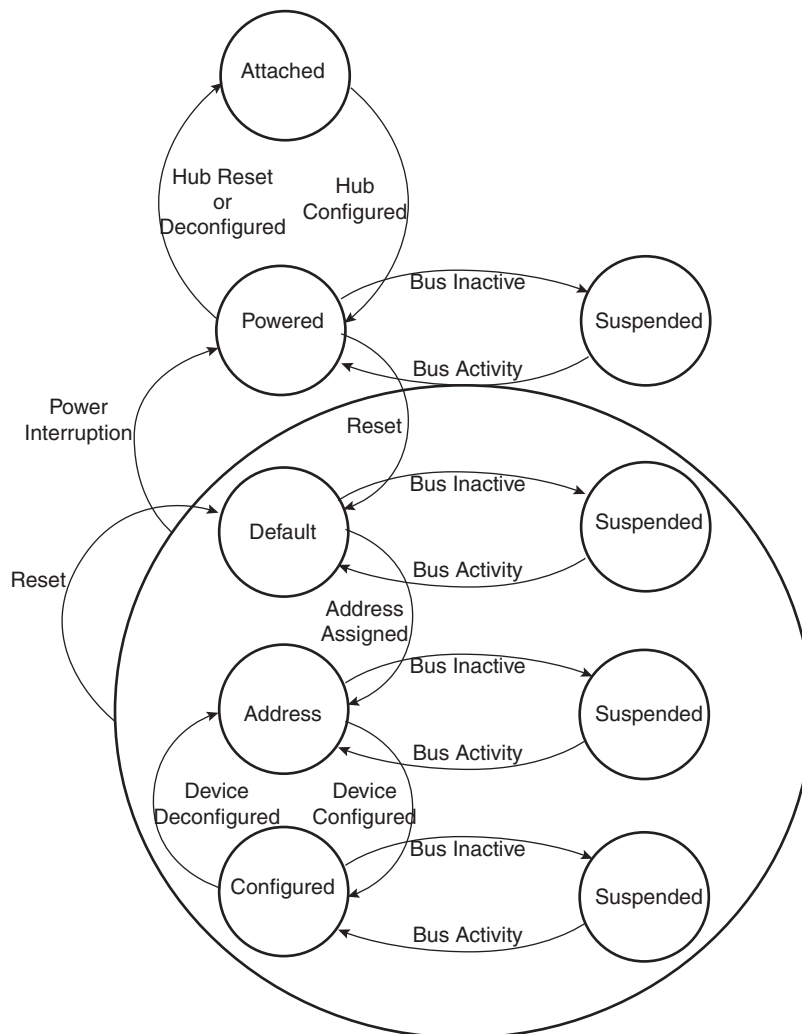

Movement from one state to another depends on the USB bus state or on standard requests sent through control transactions via the default endpoint (endpoint 0).

After a period of bus inactivity, the USB device enters Suspend Mode. Accepting Suspend/Resume requests from the USB host is mandatory. Constraints in Suspend Mode are very strict for bus-powered applications; devices may not consume more than 500 μ A on the USB bus.

While in Suspend Mode, the host may wake up a device by sending a resume signal (bus activity) or a USB device may send a wake-up request to the host, e.g., waking up a PC by moving a USB mouse.

The wake-up feature is not mandatory for all devices and must be negotiated with the host.

32.5.10.2 From Powered State to Default State (Reset)

After its connection to a USB host, the USB device waits for an end-of-bus reset. The unmasked flag ENDRESET is set in the IEN register and an interrupt is triggered.

Once the ENDRESET interrupt has been triggered, the device enters Default State. In this state, the USBA software must:

- Enable the default endpoint, setting the EPT_ENABL flag in the EPTCTLENB[0] register and, optionally, enabling the interrupt for endpoint 0 by writing 1 in EPT_INT_0 of the IEN register. The enumeration then begins by a control transfer.
- Configure the Interrupt Mask Register which has been reset by the USB reset detection
- Enable the transceiver.

In this state, the EN_USBA bit in CTRL register must be enabled.

32.5.10.3 From Default State to Address State (Address Assigned)

After a Set Address standard device request, the USB host peripheral enters the address state.

Warning: before the device enters address state, it must achieve the Status IN transaction of the control transfer, i.e., the USBA device sets its new address once the TX_COMPLT flag in the EPTCTL[0] register has been received and cleared.

To move to address state, the driver software sets the DEV_ADDR field and the FADDR_EN flag in the CTRL register.

32.5.10.4 From Address State to Configured State (Device Configured)

Once a valid Set Configuration standard request has been received and acknowledged, the device enables endpoints corresponding to the current configuration. This is done by setting the BK_NUMBER, EPT_TYPE, EPT_DIR and EPT_SIZE fields in the EPTCFGx registers and enabling them by setting the EPT_ENABL flag in the EPTCTLENBx registers, and, optionally, enabling corresponding interrupts in the IEN register.

32.5.10.5 Entering Suspend State (Bus Activity)

When a Suspend (no bus activity on the USB bus) is detected, the DET_SUSPD signal in the INTSTA register is set. This triggers an interrupt if the corresponding bit is set in the IEN register. This flag is cleared by writing to the CLRINT register. Then the device enters Suspend Mode.

In this state bus powered devices must drain less than 500 μ A from the 5V VBUS. As an example, the microcontroller switches to slow clock, disables the PLL and main oscillator, and goes into Idle Mode. It may also switch off other devices on the board.

The USBAUSBA device peripheral clocks can be switched off. Resume event is asynchronously detected.

32.5.10.6 Receiving a Host Resume

In Suspend mode, a resume event on the USB bus line is detected asynchronously, transceiver and clocks disabled (however the pull-up should not be removed).

Once the resume is detected on the bus, the signal WAKE_UP in the INTSTA is set. It may generate an interrupt if the corresponding bit in the IEN register is set. This interrupt may be used to wake-up the core, enable PLL and main oscillators and configure clocks.

32.5.10.7 Sending an External Resume

In Suspend State it is possible to wake-up the host by sending an external resume.

The device waits at least 5 ms after being entered in Suspend State before sending an external resume.

The device must force a K state from 1 to 15 ms to resume the host.

32.5.11 Test Mode

A device must support the TEST_MODE feature when in the Default, Address or Configured High Speed device states.

TEST_MODE can be:

- Test_J
- Test_K
- Test_Packet
- Test_SEO_NAK

(See [Section 32.6.11 "USBA Test Register" on page 635](#) for definitions of each test mode.)

```
const char test_packet_buffer[] = {
    // JKJKJKJK * 9
    0x00, 0x00, 0x00, 0x00, 0x00, 0x00, 0x00, 0x00, 0x00, 0x00,
    // JJKKJJKK * 8
    0xAA, 0xAA, 0xAA, 0xAA, 0xAA, 0xAA, 0xAA, 0xAA,
    // JJKKJJKK * 8
    0xEE, 0xEE, 0xEE, 0xEE, 0xEE, 0xEE, 0xEE, 0xEE,
    // JJJJJJJKKKKKKK * 8
    0xFE, 0xFF, 0xFF, 0xFF, 0xFF, 0xFF, 0xFF, 0xFF, 0xFF, 0xFF, 0xFF,
    // JJJJJJJK * 8
    0x7F, 0xBF, 0xDF, 0xEF, 0xF7, 0xFB, 0xFD,
    // {JKKKKKKK * 10}, JK
    0xFC, 0x7E, 0xBF, 0xDF, 0xEF, 0xF7, 0xFB, 0xFD, 0x7E
};
```

32.6 USB High Speed Device (USBA) User Interface

Table 32-6. Register Mapping

Offset	Register	Name	Access	Reset
0x00	USBA Control Register	CTRL	Read/Write	0x0000_0200
0x04	USBA Frame Number Register	FNUM	Read	0x0000_0000
0x08 - 0x0C	Reserved	–	–	–
0x10	USBA Interrupt Enable Register	IEN	Read/Write	0x0000_0010
0x14	USBA Interrupt Status Register	INTSTA	Read	0x0000_0000
0x18	USBA Clear Interrupt Register	CLRINT	Write	–
0x1C	USBA Endpoints Reset Register	EPTRST	Write	–
0x20 - 0xCC	Reserved	–	–	–
0xD0	USBA Test SOF Counter Register	TSTSOFCNT	Read/Write	0x0000_0000
0xD4	USBA Test A Counter Register	TSTCNTA	Read/Write	0x0000_0000
0xD8	USBA Test B Counter Register	TSTCNTB	Read/Write	0x0000_0000
0xDC	USBA Test Mode Register	TSTMODEREG	Read/Write	0x0000_0000
0xE0	USBA Test Register	TST	Read/Write	0x0000_0000
0xE4 - 0xE8	Reserved	–	–	–
0xEC	USBA PADDRSIZE Register	IPADDRSIZE	Read	0x0000_4000
0xF0	USBA Name1 Register	IPNAME1	Read	0x4855_5342
0xF4	USBA Name2 Register	IPNAME2	Read	0x3244_4556
0xF8	USBA Features Register	IPFEATURES	Read	
0xFC	USBA IP Version Register	IPVERSION	Read	
0x100	USBA Endpoint Configuration Register	EPTCFGx	Read/Write	0x0000_0000
0x104	USBA Endpoint Control Enable Register	EPTCTLENBx	Write	–
0x108	USBA Endpoint Control Disable Register	EPTCTLDISx	Write	–
0x10C	USBA Endpoint Control Register	EPTCTLx	Read	0x0000_0000 ⁽¹⁾
0x110	Reserved	–	–	–
0x114	USBA Endpoint Set Status Register	EPTSETSTAx	Write	–
0x118	USBA Endpoint Clear Status Register	EPTCLRSTAx	Write	–
0x11C	USBA Endpoint Status Register	EPTSTA	Read	0x0000_0040
0x120 - 0x1FC	Endpoints 1 to 7			
0x200 - 0x2FC	Endpoints 8 to 15			
0x200 - 0x30C	Reserved	–	–	–
0x300 - 0x30C	Reserved	–	–	–
0x310	USBA DMA Next Descriptor Address Register	DMANXTDSCx	Read/Write	0x0000_0000
0x314	USBA DMA Channelx Address Register	DMAADDRESSx	Read/Write	0x0000_0000

Table 32-6. Register Mapping (Continued)

Offset	Register	Name	Access	Reset
0x318	USBA DMA Channelx Control Register	DMACONTROLx	Read/Write	0x0000_0000
0x31C	USBA DMA Channelx Status Register	DMASTATUSx	Read/Write	0x0000_0000
0x320 - 0x37C	DMA Channel 2 to 7			

Note: 1. The reset value for EPTCTL0 is 0x0000_0001

32.6.1 USBA Control Register

Name: CTRL
Access Type: Read/Write

31	30	29	28	27	26	25	24
–	–	–	–	–	–	–	–
23	22	21	20	19	18	17	16
–	–	–	–	–	–	–	–
15	14	13	12	11	10	9	8
–	–	–	–	–	REWAKEUP	DETACH	EN_USBA
7	6	5	4	3	2	1	0
FADDR_EN	DEV_ADDR						

- **DEV_ADDR: USBA Address**

Read:

This field contains the default address (0) after power-up or USBA bus reset.

Write:

This field is written with the value set by a SET_ADDRESS request received by the device firmware.

- **FADDR_EN: Function Address Enable**

Read:

0 = Device is not in address state.

1 = Device is in address state.

Write:

0 = only the default function address is used (0).

1 = this bit is set by the device firmware after a successful status phase of a SET_ADDRESS transaction. When set, the only address accepted by the USBA controller is the one stored in the USBA Address field. It will not be cleared afterwards by the device firmware. It is cleared by hardware on hardware reset, or when USBA bus reset is received (see above).

- **EN_USBA: USBA Enable**

Read:

0 = USBA is disabled.

1 = USBA is enabled.

Write:

0 = disable and reset the USBA controller, disable the USBA transceiver.

1 = enables the USBA controller.

- **DETACH: Detach Command**

Read:

0 = USBA is attached.

1 = USBA is detached, UTMI transceiver is suspended.

Write:

0 = pull up the DP line (attach command).

1 = simulate a detach on the USBA line and force the UTMI transceiver into suspend state (Suspend M = 0).

- **REWAKEUP: Send Remote Wake Up**

Read:

0 = Remote Wake Up is disabled.

1 = Remote Wake Up is enabled.

Write:

0 = no effect.

1 = force an external interrupt on the USBA controller for Remote Wake UP purposes.

An Upstream Resume is sent only after the USBA bus has been in SUSPEND state for at least 5 ms.

This bit is automatically cleared by hardware at the end of the Upstream Resume.

32.6.2 USBA Frame Number Register

Name: FNUM

Access Type: Read

31	30	29	28	27	26	25	24
FNUM_ERR	–	–	–	–	–	–	–
23	22	21	20	19	18	17	16
–	–	–	–	–	–	–	–
15	14	13	12	11	10	9	8
–	–	FRAME_NUMBER					
7	6	5	4	3	2	1	0
FRAME_NUMBER					MICRO_FRAME_NUM		

- **MICRO_FRAME_NUM: Microframe Number**

Number of the received microframe (0 to 7) in one frame. This field is reset at the beginning of each new frame (1 ms).

One microframe is received each 125 microseconds (1 ms/8).

- **FRAME_NUMBER: Frame Number as defined in the Packet Field Formats**

This field is provided in the last received SOF packet (see INT_SOF in the [USBA Interrupt Status Register](#)).

- **FNUM_ERR: Frame Number CRC Error**

This bit is set by hardware when a corrupted Frame Number in Start of Frame packet (or Micro SOF) is received.

This bit and the INT_SOF (or MICRO_SOF) interrupt are updated at the same time.

32.6.3 USBA Interrupt Enable Register

Name: IEN

Access Type: Read/Write

31	30	29	28	27	26	25	24
	DMA_INT_6	DMA_INT_5	DMA_INT_4	DMA_INT_3	DMA_INT_2	DMA_INT_1	–
23	22	21	20	19	18	17	16
15	14	13	12	11	10	9	8
EPT_INT_7	EPT_INT_6	EPT_INT_5	EPT_INT_4	EPT_INT_3	EPT_INT_2	EPT_INT_1	EPT_INT_0
7	6	5	4	3	2	1	0
UPSTR_RES	ENDOFRSM	WAKE_UP	ENDRESET	INT_SOF	MICRO_SOF	DET_SUSPD	–

- **DET_SUSPD: Suspend Interrupt Enable**

Read:

0 = Suspend Interrupt is disabled.

1 = Suspend Interrupt is enabled.

Write

0 = disable Suspend Interrupt.

1 = enable Suspend Interrupt.

- **MICRO_SOF: Micro-SOF Interrupt Enable**

Read:

0 = Micro-SOF Interrupt is disabled.

1 = Micro-SOF Interrupt is enabled.

Write

0 = disable Micro-SOF Interrupt.

1 = enable Micro-SOF Interrupt.

- **INT_SOF: SOF Interrupt Enable**

Read:

0 = SOF Interrupt is disabled.

1 = SOF Interrupt is enabled.

Write

0 = disable SOF Interrupt.

1 = enable SOF Interrupt.

- **ENDRESET: End Of Reset Interrupt Enable**

Read:

0 = End Of Reset Interrupt is disabled.

1 = End Of Reset Interrupt is enabled.

Write

0 = disable End Of Reset Interrupt.

1 = enable End Of Reset Interrupt.

- **WAKE_UP: Wake Up CPU Interrupt Enable**

Read:

0 = Wake Up CPU Interrupt is disabled.

1 = Wake Up CPU Interrupt is enabled.

Write

0 = disable Wake Up CPU Interrupt.

1 = enable Wake Up CPU Interrupt.

- **ENDOFRSM: End Of Resume Interrupt Enable**

Read:

0 = Resume Interrupt is disabled.

1 = Resume Interrupt is enabled.

Write

0 = disable Resume Interrupt.

1 = enable Resume Interrupt.

- **UPSTR_RES: Upstream Resume Interrupt Enable**

Read:

0 = Upstream Resume Interrupt is disabled.

1 = Upstream Resume Interrupt is enabled.

Write

0 = disable Upstream Resume Interrupt.

1 = enable Upstream Resume Interrupt.

- **EPT_INT_x: Endpointx Interrupt Enable**

Read:

0 = the interrupts for this endpoint are disabled.

1 = the interrupts for this endpoint are enabled.

Write

0 = disable the interrupts for this endpoint.

1 = enable the interrupts for this endpoint.

- **DMA_INT_x: DMA Channelx Interrupt Enable**

Read:

0 = the interrupts for this channel are disabled.

1 = the interrupts for this channel are enabled.

Write

0 = disable the interrupts for this channel.

1 = enable the interrupts for this channel.

32.6.4 USBA Interrupt Status Register

Name: INTSTA

Access Type: Read-only

31	30	29	28	27	26	25	24
	DMA_INT_6	DMA_INT_5	DMA_INT_4	DMA_INT_3	DMA_INT_2	DMA_INT_1	–
23	22	21	20	19	18	17	16
15	14	13	12	11	10	9	8
EPT_INT_7	EPT_INT_6	EPT_INT_5	EPT_INT_4	EPT_INT_3	EPT_INT_2	EPT_INT_1	EPT_INT_0
7	6	5	4	3	2	1	0
UPSTR_RES	ENDOFRSM	WAKE_UP	ENDRESET	INT_SOF	MICRO_SOF	DET_SUSPD	SPEED

- **SPEED: Speed Status**

0 = reset by hardware when the hardware is in Full Speed mode.

1 = set by hardware when the hardware is in High Speed mode

- **DET_SUSPD: Suspend Interrupt**

0 = cleared by setting the DET_SUSPD bit in CLRINT register

1 = set by hardware when a USBA Suspend (Idle bus for three frame periods, a J state for 3 ms) is detected. This triggers a USBA interrupt when the DET_SUSPD bit is set in IEN register.

- **MICRO_SOF: Micro Start Of Frame Interrupt**

0 = cleared by setting the MICRO_SOF bit in CLRINT register.

1 = set by hardware when an USBA micro start of frame PID (SOF) has been detected (every 125 us) or synthesized by the macro. This triggers a USBA interrupt when the MICRO_SOF bit is set in IEN. In case of detected SOF, the MICRO_FRAME_NUM field in FNUM register is incremented and the FRAME_NUMBER field doesn't change.

Note: The Micro Start Of Frame Interrupt (MICRO_SOF), and the Start Of Frame Interrupt (INT_SOF) are not generated at the same time.

- **INT_SOF: Start Of Frame Interrupt**

0 = cleared by setting the INT_SOF bit in CLRINT.

1 = set by hardware when an USBA Start Of Frame PID (SOF) has been detected (every 1 ms) or synthesized by the macro. This triggers a USBA interrupt when the INT_SOF bit is set in IEN register. In case of detected SOF, in High Speed mode, the MICRO_FRAME_NUMBER field is cleared in FNUM register and the FRAME_NUMBER field is updated.

- **ENDRESET: End Of Reset Interrupt**

0 = cleared by setting the ENDRESET bit in CLRINT.

1 = set by hardware when an End Of Reset has been detected by the USBA controller. This triggers a USBA interrupt when the ENDRESET bit is set in IEN.

- **WAKE_UP: Wake Up CPU Interrupt**

0 = cleared by setting the WAKE_UP bit in CLRINT.

1 = set by hardware when the USBA controller is in SUSPEND state and is re-activated by a filtered non-idle signal from the USBA line (not by an upstream resume). This triggers a USBA interrupt when the WAKE_UP bit is set in IEN register. When receiving this interrupt, the user has to enable the device controller clock prior to operation.

Note: this interrupt is generated even if the device controller clock is disabled.

- **ENDOFRSM: End Of Resume Interrupt**

0 = cleared by setting the ENDOFRSM bit in CLRINT.

1 = set by hardware when the USBA controller detects a good end of resume signal initiated by the host. This triggers a USBA interrupt when the ENDOFRSM bit is set in IEN.

- **UPSTR_RES: Upstream Resume Interrupt**

0 = cleared by setting the UPSTR_RES bit in CLRINT.

1 = set by hardware when the USBA controller is sending a resume signal called “upstream resume”. This triggers a USBA interrupt when the UPSTR_RES bit is set in IEN.

- **EPT_INT_x: Endpointx Interrupt**

0 = reset when the EPTSTAx interrupt source is cleared.

1 = set by hardware when an interrupt is triggered by the EPTSTAx register and this endpoint interrupt is enabled by the EPT_INT_x bit in IEN.

- **DMA_INT_x: DMA Channelx Interrupt**

0 = reset when the DMASTATUSx interrupt source is cleared.

1 = set by hardware when an interrupt is triggered by the DMA Channelx and this endpoint interrupt is enabled by the DMA_INT_x bit in IEN.

32.6.5 USBA Clear Interrupt Register

Name: CLRINT

Access Type: Write only

31	30	29	28	27	26	25	24
–	–	–	–	–	–	–	–
23	22	21	20	19	18	17	16
–	–	–	–	–	–	–	–
15	14	13	12	11	10	9	8
–	–	–	–	–	–	–	–
7	6	5	4	3	2	1	0
UPSTR_RES	ENDOFRSM	WAKE_UP	ENDRESET	INT_SOF	MICRO_SOF	DET_SUSPD	–

- **DET_SUSPD: Suspend Interrupt Clear**

0 = no effect.

1 = clear the DET_SUSPD bit in INTSTA.

- **MICRO_SOF: Micro Start Of Frame Interrupt Clear**

0 = no effect.

1 = clear the MICRO_SOF bit in INTSTA.

- **INT_SOF: Start Of Frame Interrupt Clear**

0 = no effect.

1 = clear the INT_SOF bit in INTSTA.

- **ENDRESET: End Of Reset Interrupt Clear**

0 = no effect.

1 = clear the ENDRESET bit in INTSTA.

- **WAKE_UP: Wake Up CPU Interrupt Clear**

0 = no effect.

1 = clear the WAKE_UP bit in INTSTA.

- **ENDOFRSM: End Of Resume Interrupt Clear**

0 = no effect.

1 = clear the ENDOFRSM bit in INTSTA.

- **UPSTR_RES: Upstream Resume Interrupt Clear**

0 = no effect.

1 = clear the UPSTR_RES bit in INTSTA.

32.6.6 USBA Endpoints Reset Register

Name: EPTRST

Access Type: Write only

31	30	29	28	27	26	25	24
–	–	–	–	–	–	–	–
23	22	21	20	19	18	17	16
–	–	–	–	–	–	–	–
15	14	13	12	11	10	9	8
7	6	5	4	3	2	1	0
RST_EPT_7	RST_EPT_6	RST_EPT_5	RST_EPT_4	RST_EPT_3	RST_EPT_2	RST_EPT_1	RST_EPT_0

• RST_EPT_x: Endpointx Reset

0 = no effect.

1 = reset the Endpointx state.

Setting this bit clears the Endpoint status EPTSTAx register, except for the TOGGLESQ_STA field.

32.6.7 USBA Test SOF Counter Register

Name: TSTSOFcnt

Access Type: Read/Write

31	30	29	28	27	26	25	24
-	-	-	-	-	-	-	-
23	22	21	20	19	18	17	16
-	-	-	-	-	-	-	-
15	14	13	12	11	10	9	8
-	-	-	-	-	-	-	-
7	6	5	4	3	2	1	0
SOFCTLOAD		SOFcntMAX					

- SOFCNTMAX: SOF Counter Max Value
- SOFCTLOAD: SOF Counter Load

32.6.8 USBA Test A Counter Register

Name: TSTCNTA

Access Type: Read/Write

31	30	29	28	27	26	25	24
-	-	-	-	-	-	-	-
23	22	21	20	19	18	17	16
-	-	-	-	-	-	-	-
15	14	13	12	11	10	9	8
CNTALOAD	CNTAMAX						
7	6	5	4	3	2	1	0
CNTAMAX							

- **CNTALOAD: A Counter Load**
- **CNTAMAX: A Counter Max Value**

32.6.9 USBA Test B Counter Register

Name: TSTCNTB

Access Type: Read/Write

31	30	29	28	27	26	25	24
-	-	-	-	-	-	-	-
23	22	21	20	19	18	17	16
-	-	-	-	-	-	-	-
15	14	13	12	11	10	9	8
-	-	-	-	-	-	-	-
7	6	5	4	3	2	1	0
CNTBLOAD	-	CNTBMAX					

- CNTBLOAD: B Counter Load
- CNTBMAX: B Counter Max Value

32.6.10 USBA Test Mode Register

Name: TSTMODEREG

Access Type: Read/Write

31	30	29	28	27	26	25	24
-	-	-	-	-	-	-	-
23	22	21	20	19	18	17	16
-	-	-	-	-	-	-	-
15	14	13	12	11	10	9	8
-	-	-	-	-	-	-	-
7	6	5	4	3	2	1	0
-	-	TSTMODE					

- TSTMODE: USBA Core TestModeReg

32.6.11 USBA Test Register

Name: TST

Access Type: Read/Write

31	30	29	28	27	26	25	24
–	–	–	–	–	–	–	–
23	22	21	20	19	18	17	16
–	–	–	–	–	–	–	–
15	14	13	12	11	10	9	8
–	–	–	–	–	–	–	–
7	6	5	4	3	2	1	0
–	–	OPMODE2	TST_PKT	TST_K	TST_J	SPEED_CFG	

- **SPEED_CFG: Speed Configuration**

Read/Write:

Speed Configuration:

00	Normal Mode: The macro is in Full Speed mode, ready to make a High Speed identification, if the host supports it and then to automatically switch to High Speed mode
01	Reserved
10	Force High Speed: Set this value to force the hardware to work in High Speed mode. Only for debug or test purpose.
11	Force Full Speed: Set this value to force the hardware to work only in Full Speed mode. In this configuration, the macro will not respond to a High Speed reset handshake

- **TST_J: Test J Mode**

Read and write:

0 = no effect.

1 = set to send the J state on the USBA line. This enables the testing of the high output drive level on the D+ line.

- **TST_K: Test K Mode**

Read and write:

0 = no effect.

1 = set to send the K state on the USBA line. This enables the testing of the high output drive level on the D- line.

- **TST_PKT: Test Packet Mode**

Read and write:

0 = no effect.

1 = set to repetitively transmit the packet stored in the current bank. This enables the testing of rise and fall times, eye patterns, jitter, and any other dynamic waveform specifications.

- **OPMODE2: OpMode2**

Read and write:

0 = no effect.

1 = set to force the OpMode signal (UTMI interface) to “10”, to disable the bit-stuffing and the NRZI encoding.

Note: For the Test mode, Test_SE0_NAK (see Universal Serial Bus Specification, Revision 2.0: 7.1.20, Test Mode Support). Force the device in High Speed mode, and configure a bulk-type endpoint. Do not fill this endpoint for sending NAK to the host.

Upon command, a port’s transceiver must enter the High Speed receive mode and remain in that mode until the exit action is taken. This enables the testing of output impedance, low level output voltage and loading characteristics. In addition, while in this mode, upstream facing ports (and only upstream facing ports) must respond to any IN token packet with a NAK handshake (only if the packet CRC is determined to be correct) within the normal allowed device response time. This enables testing of the device squelch level circuitry and, additionally, provides a general purpose stimulus/response test for basic functional testing.

32.6.12 USBA PADDRSIZE Register

Name: IPPADDRSIZE

Access Type: Read-only

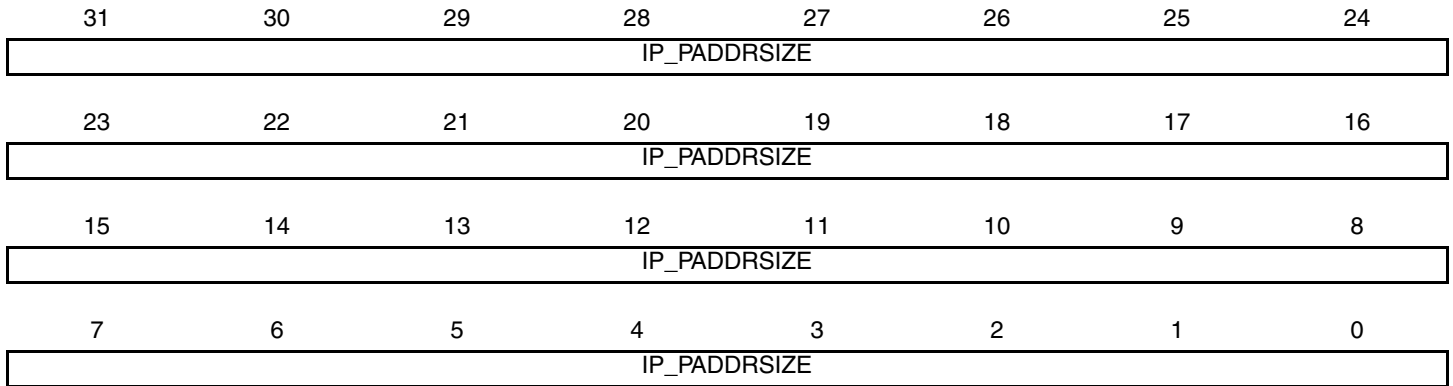

• IP_PADDRSIZE

$2^{\text{PADDR_SIZE}}$

PB address bus aperture of the USBA

32.6.13 USBA Name1 Register

Name: IPNAME1

Access Type: Read-only

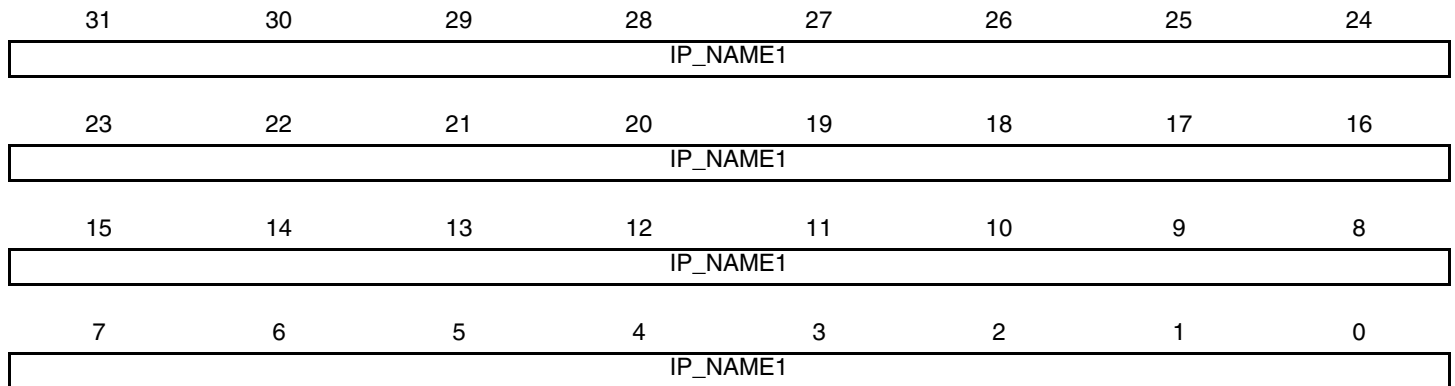

- IP_NAME1
ASCII string "HUSB"

32.6.14 USBA Name2 Register

Name: IPNAME2

Access Type: Read-only

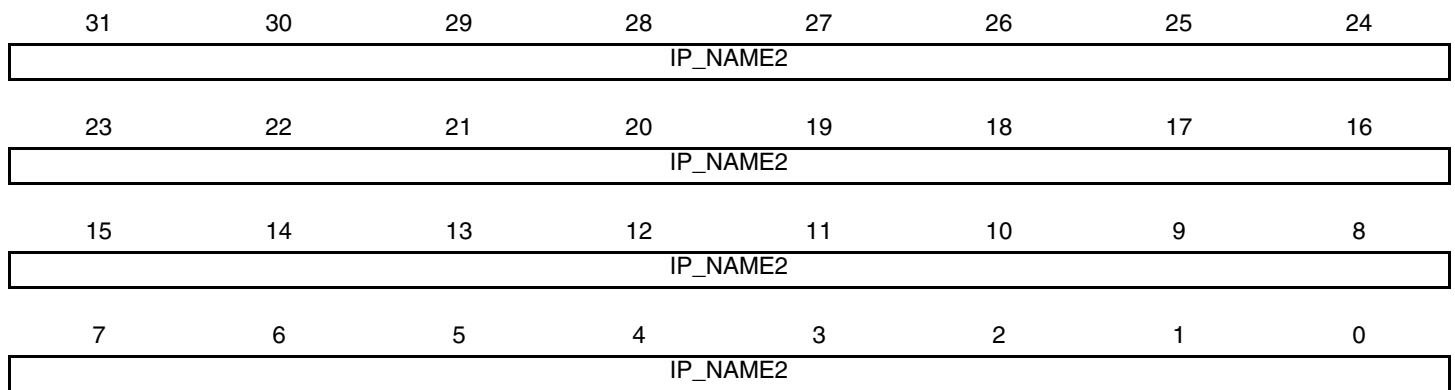

- IP_NAME2

ASCII string "2DEV"

32.6.15 USB A Features Register

Name: IPFEATURES

Access Type: Read-only

31	30	29	28	27	26	25	24
23	22	21	20	19	18	17	16
ISO_EPT_7	ISO_EPT_6	ISO_EPT_5	ISO_EPT_4	ISO_EPT_3	ISO_EPT_2	ISO_EPT_1	DATAB16_8
15	14	13	12	11	10	9	8
BW_DPRAM	FIFO_MAX_SIZE			DMA_FIFO_WORD_DEPTH			
7	6	5	4	3	2	1	0
DMA_B_SIZ	DMA_CHANNEL_NBR			EPT_NBR_MAX			

- **EPT_NBR_MAX: Max Number of Endpoints**

Give the max number of endpoints.

0 = if 16 endpoints are hardware implemented.

1 = if 1 endpoint is hardware implemented.

2 = if 2 endpoints are hardware implemented.

...

15 = if 15 endpoints are hardware implemented.

- **DMA_CHANNEL_NBR: Number of DMA Channels**

Give the number of DMA channels.

1 = if 1 DMA channel is hardware implemented.

2 = if 2 DMA channels are hardware implemented.

...

7 = if 7 DMA channels are hardware implemented.

- **DMA_B_SIZ: DMA Buffer Size**

0 = if the DMA Buffer size is 16 bits.

1 = if the DMA Buffer size is 24 bits.

- **DMA_FIFO_WORD_DEPTH: DMA FIFO Depth in Words**

0 = if FIFO is 16 words deep.

1 = if FIFO is 1 word deep.

2 = if FIFO is 2 words deep.

...

15 = if FIFO is 15 words deep.

- **FIFO_MAX_SIZE: DPRAM Size**

0 = if DPRAM is 128 bytes deep.

1 = if DPRAM is 256 bytes deep.

2 = if DPRAM is 512 bytes deep.

3 = if DPRAM is 1024 bytes deep.

4 = if DPRAM is 2048 bytes deep.

5 = if DPRAM is 4096 bytes deep.

6 = if DPRAM is 8192 bytes deep.

7 = if DPRAM is 16384 bytes deep.

- **BW_DPRAM: DPRAM Byte Write Capability**

0 = if DPRAM Write Data Shadow logic is implemented.

1 = if DPRAM is byte write capable.

- **DATAB16_8: UTMI DataBus16_8**

0 = if the UTMI uses an 8-bit parallel data interface (60 MHz, unidirectional).

1 = if the UTMI uses a 16-bit parallel data interface (30 MHz, bidirectional).

- **ISO_EPT_x: Endpointx High Bandwidth Isochronous Capability**

0 = if the endpoint does not have isochronous High Bandwidth Capability.

1 = if the endpoint has isochronous High Bandwidth Capability.

32.6.16 USBA IP Version Register

Name: IPVERSION

Access Type: Read-only

31	30	29	28	27	26	25	24
-	-	-	-	-	-	-	-
23	22	21	20	19	18	17	16
-	-	-	-	-	METAL_FIX_NUM		
15	14	13	12	11	10	9	8
VERSION_NUM							
7	6	5	4	3	2	1	0
VERSION_NUM							

- **VERSION_NUM: IP Version**

Give the IP version.

- **METAL_FIX_NUM: Number of metal fixes**

Give the number of metal fixes.

32.6.17 USB A Endpoint Configuration Register

Name: EPTCFGx

Access Type: Read/Write

31	30	29	28	27	26	25	24
EPT_MAPD	–	–	–	–	–	–	–
23	22	21	20	19	18	17	16
–	–	–	–	–	–	–	–
15	14	13	12	11	10	9	8
–	–	–	–	–	–	NB_TRANS	
7	6	5	4	3	2	1	0
BK_NUMBER		EPT_TYPE		EPT_DIR		EPT_SIZE	

- **EPT_SIZE: Endpoint Size**

Read and write:

Set this field according to the endpoint size in bytes (see [Section 32.5.4 "Endpoint Configuration"](#)).

Endpoint Size

000	8 bytes
001	16 bytes
010	32 bytes
011	64 bytes
100	128 bytes
101	256 bytes
110	512 bytes
111	1024 bytes ⁽¹⁾

Note: 1. 1024 bytes is only for isochronous endpoint.

- **EPT_DIR: Endpoint Direction**

Read and write:

0 = Clear this bit to configure OUT direction for Bulk, Interrupt and Isochronous endpoints.

1 = set this bit to configure IN direction for Bulk, Interrupt and Isochronous endpoints.

For Control endpoints this bit has no effect and should be left at zero.

- **EPT_TYPE: Endpoint Type**

Read and write:

Set this field according to the endpoint type (see [Section 32.5.4 "Endpoint Configuration"](#)).

(Endpoint 0 should always be configured as control)

Endpoint Type:

00	Control endpoint
01	Isochronous endpoint
10	Bulk endpoint
11	Interrupt endpoint

• **BK_NUMBER: Number of Banks**

Read and write:

Set this field according to the endpoint's number of banks (see [Section 32.5.4 "Endpoint Configuration"](#)).

Number of Banks

00	Zero bank, the endpoint is not mapped in memory
01	One bank (bank 0)
10	Double bank (Ping-Pong: bank 0/bank 1)
11	Triple bank (bank 0/bank 1/bank 2)

• **NB_TRANS: Number Of Transaction per Microframe**

Read and Write:

The Number of transactions per microframe is set by software.

Note: Meaningful for high bandwidth isochronous endpoint only.

• **EPT_MAPD: Endpoint Mapped**

Read-only:

0 = the user should reprogram the register with correct values.

1 = set by hardware when the endpoint size (EPT_SIZE) and the number of banks (BK_NUMBER) are correct regarding:

- the fifo max capacity (FIFO_MAX_SIZE in IPFEATURES register)
- the number of endpoints/banks already allocated
- the number of allowed banks for this endpoint

32.6.18 USB A Endpoint Control Enable Register

Name: EPTCTLENBx

Access Type: Write-only

31	30	29	28	27	26	25	24
SHRT_PCKT	–	–	–	–	–	–	–
23	22	21	20	19	18	17	16
–	–	–	–	–	BUSY_BANK	–	–
15	14	13	12	11	10	9	8
NAK_OUT	NAK_IN/ ERR_FLUSH	STALL_SNT/ ERR_CRISO/ ERR_NBTRA	RX_SETUP/ ERR_FL_ISO	TX_PK_RDY/ ERR_TRANS	TX_COMPLT	RX_BK_RDY	ERR_OVFLW
7	6	5	4	3	2	1	0
MDATA_RX	DATA_X_RX	–	NYET_DIS	INTDIS_DMA	–	AUTO_VALID	EPT_ENABL

For additional information, see ["USB A Endpoint Control Register" on page 649](#).

- **EPT_ENABL: Endpoint Enable**

0 = no effect.

1 = enable endpoint according to the device configuration.

- **AUTO_VALID: Packet Auto-Valid Enable**

0 = no effect.

1 = enable this bit to automatically validate the current packet and switch to the next bank for both IN and OUT transfers.

- **INTDIS_DMA: Interrupts Disable DMA**

0 = no effect.

1 = If set, when an enabled endpoint-originated interrupt is triggered, the DMA request is disabled.

- **NYET_DIS: NYET Disable (Only for High Speed Bulk OUT endpoints)**

0 = no effect.

1 = forces an ACK response to the next High Speed Bulk OUT transfer instead of a NYET response.

- **DATA_X_RX: DATAx Interrupt Enable (Only for high bandwidth Isochronous OUT endpoints)**

0 = no effect.

1 = enable DATAx Interrupt.

- **MDATA_RX: MDATA Interrupt Enable (Only for high bandwidth Isochronous OUT endpoints)**

0 = no effect.

1 = enable MDATA Interrupt.

- **ERR_OVFLW: Overflow Error Interrupt Enable**

0 = no effect.

1 = enable Overflow Error Interrupt.

- **RX_BK_RDY: Received OUT Data Interrupt Enable**

0 = no effect.

1 = enable Received OUT Data Interrupt.

- **TX_COMPLT: Transmitted IN Data Complete Interrupt Enable**

0 = no effect.

1 = enable Transmitted IN Data Complete Interrupt.

- **TX_PK_RDY/ERR_TRANS: TX Packet Ready/Transaction Error Interrupt Enable**

0 = no effect.

1 = enable TX Packet Ready/Transaction Error Interrupt.

- **RX_SETUP/ERR_FL_ISO: Received SETUP/Error Flow Interrupt Enable**

0 = no effect.

1 = enable RX_SETUP/Error Flow ISO Interrupt.

- **STALL_SNT/ERR_CRISO/ERR_NBTRA: Stall Sent /ISO CRC Error/Number of Transaction Error Interrupt Enable**

0 = no effect.

1 = enable Stall Sent/Error CRC ISO/Error Number of Transaction Interrupt.

- **NAK_IN/ERR_FLUSH: NAKIN/Bank Flush Error Interrupt Enable**

0 = no effect.

1 = enable NAKIN/Bank Flush Error Interrupt.

- **NAK_OUT: NAKOUT Interrupt Enable**

0 = no effect.

1 = enable NAKOUT Interrupt.

- **BUSY_BANK: Busy Bank Interrupt Enable**

0 = no effect.

1 = enable Busy Bank Interrupt.

- **SHRT_PCKT: Short Packet Send/Short Packet Interrupt Enable**

For OUT endpoints:

0 = no effect.

1 = enable Short Packet Interrupt.

For IN endpoints:

Guarantees short packet at end of DMA Transfer if the DMACONTROLx register END_B_EN and EPTCTLx register AUTOVALID bits are also set.

32.6.19 USB A Endpoint Control Disable Register

Name: EPTCTLDISx

Access Type: Write-only

31	30	29	28	27	26	25	24
SHRT_PCKT	–	–	–	–	–	–	–
23	22	21	20	19	18	17	16
–	–	–	–	–	BUSY_BANK	–	–
15	14	13	12	11	10	9	8
NAK_OUT	NAK_IN/ ERR_FLUSH	STALL_SNT/ ERR_CRISO/ ERR_NBTRA	RX_SETUP/ ERR_FL_ISO	TX_PK_RDY/ ERR_TRANS	TX_COMPLT	RX_BK_RDY	ERR_OVFLW
7	6	5	4	3	2	1	0
MDATA_RX	DATA_X_RX	–	NYET_DIS	INTDIS_DMA	–	AUTO_VALID	EPT_DISABL

For additional information, see ["USB A Endpoint Control Register" on page 649](#).

- **EPT_DISABL: Endpoint Disable**

0 = no effect.

1 = disable endpoint.

- **AUTO_VALID: Packet Auto-Valid Disable**

0 = no effect.

1 = disable this bit to not automatically validate the current packet.

- **INTDIS_DMA: Interrupts Disable DMA**

0 = no effect.

1 = disable the "Interrupts Disable DMA".

- **NYET_DIS: NYET Enable (Only for High Speed Bulk OUT endpoints)**

0 = no effect.

1 = let the hardware handle the handshake response for the High Speed Bulk OUT transfer.

- **DATA_X_RX: DATAx Interrupt Disable (Only for High Bandwidth Isochronous OUT endpoints)**

0 = no effect.

1 = disable DATAx Interrupt.

- **MDATA_RX: MDATA Interrupt Disable (Only for High Bandwidth Isochronous OUT endpoints)**

0 = no effect.

1 = disable MDATA Interrupt.

- **ERR_OVFLW: Overflow Error Interrupt Disable**

0 = no effect.

1 = disable Overflow Error Interrupt.

- **RX_BK_RDY: Received OUT Data Interrupt Disable**

0 = no effect.

1 = disable Received OUT Data Interrupt.

- **TX_COMPLT: Transmitted IN Data Complete Interrupt Disable**

0 = no effect.

1 = disable Transmitted IN Data Complete Interrupt.

- **TX_PK_RDY/ERR_TRANS: TX Packet Ready/Transaction Error Interrupt Disable**

0 = no effect.

1 = disable TX Packet Ready/Transaction Error Interrupt.

- **RX_SETUP/ERR_FL_ISO: Received SETUP/Error Flow Interrupt Disable**

0 = no effect.

1 = disable RX_SETUP/Error Flow ISO Interrupt.

- **STALL_SNT/ERR_CRISO/ERR_NBTRA: Stall Sent/ISO CRC Error/Number of Transaction Error Interrupt Disable**

0 = no effect.

1 = disable Stall Sent/Error CRC ISO/Error Number of Transaction Interrupt.

- **NAK_IN/ERR_FLUSH: NAKIN/bank flush error Interrupt Disable**

0 = no effect.

1 = disable NAKIN/ Bank Flush Error Interrupt.

- **NAK_OUT: NAKOUT Interrupt Disable**

0 = no effect.

1 = disable NAKOUT Interrupt.

- **BUSY_BANK: Busy Bank Interrupt Disable**

0 = no effect.

1 = disable Busy Bank Interrupt.

- **SHRT_PCKT: Short Packet Interrupt Disable**

For OUT endpoints:

0 = no effect.

1 = disable Short Packet Interrupt.

For IN endpoints:

Never automatically add a zero length packet at end of DMA transfer.

32.6.20 USBA Endpoint Control Register

Name: EPTCTLx

Access Type: Read-only

31	30	29	28	27	26	25	24
SHRT_PCKT	–	–	–	–	–	–	–
23	22	21	20	19	18	17	16
–	–	–	–	–	BUSY_BANK	–	–
15	14	13	12	11	10	9	8
NAK_OUT	NAK_IN/ ERR_FLUSH	STALL_SNT/ ERR_CRISO/ ERR_NBTRA	RX_SETUP/ ERR_FL_ISO	TX_PK_RDY/ ERR_TRANS	TX_COMPLT	RX_BK_RDY	ERR_OVFLW
7	6	5	4	3	2	1	0
MDATA_RX	DATA_RX	–	NYET_DIS	INTDIS_DMA	–	AUTO_VALID	EPT_ENABL

- **EPT_ENABL: Endpoint Enable**

0 = If cleared, the endpoint is disabled according to the device configuration. Endpoint 0 should always be enabled after a hardware or USBA bus reset and participate in the device configuration.

1 = If set, the endpoint is enabled according to the device configuration.

- **AUTO_VALID: Packet Auto-Valid Enabled (Not for CONTROL Endpoints)**

Set this bit to automatically validate the current packet and switch to the next bank for both IN and OUT endpoints.

For IN Transfer:

If this bit is set, then the EPTSTAx register TX_PK_RDY bit is set automatically when the current bank is full and at the end of DMA buffer if the DMACONTROLx register END_B_EN bit is set.

The user may still set the EPTSTAx register TX_PK_RDY bit if the current bank is not full, unless the user wants to send a Zero Length Packet by software.

For OUT Transfer:

If this bit is set, then the EPTSTAx register RX_BK_RDY bit is automatically reset for the current bank when the last packet byte has been read from the bank FIFO or at the end of DMA buffer if the DMACONTROLx register END_B_EN bit is set. For example, to truncate a padded data packet when the actual data transfer size is reached.

The user may still clear the EPTSTAx register RX_BK_RDY bit, for example, after completing a DMA buffer by software if DMACONTROLx register END_B_EN bit was disabled or in order to cancel the read of the remaining data bank(s).

- **INTDIS_DMA: Interrupt Disables DMA**

If set, when an enabled endpoint-originated interrupt is triggered, the DMA request is disabled regardless of the IEN register EPT_INT_x bit for this endpoint. Then, the firmware will have to clear or disable the interrupt source or clear this bit if transfer completion is needed.

If the exception raised is associated with the new system bank packet, then the previous DMA packet transfer is normally completed, but the new DMA packet transfer is not started (not requested).

If the exception raised is not associated to a new system bank packet (NAK_IN, NAK_OUT, ERR_FL_ISO...), then the request cancellation may happen at any time and may immediately stop the current DMA transfer.

This may be used, for example, to identify or prevent an erroneous packet to be transferred into a buffer or to complete a DMA buffer by software after reception of a short packet, or to perform buffer truncation on ERR_FL_ISO interrupt for adaptive rate.

- **NYET_DIS: NYET Disable (Only for High Speed Bulk OUT endpoints)**

0 = If clear, this bit lets the hardware handle the handshake response for the High Speed Bulk OUT transfer.

1 = If set, this bit forces an ACK response to the next High Speed Bulk OUT transfer instead of a NYET response.

Note: According to the *Universal Serial Bus Specification, Rev 2.0* (8.5.1.1 NAK Responses to OUT/DATA During PING Protocol), a NAK response to an HS Bulk OUT transfer is expected to be an unusual occurrence.

- **DATA_RX: DATAx Interrupt Enabled (Only for High Bandwidth Isochronous OUT endpoints)**

0 = no effect.

1 = send an interrupt when a DATA2, DATA1 or DATA0 packet has been received meaning the whole microframe data payload has been received.

- **MDATA_RX: MDATA Interrupt Enabled (Only for High Bandwidth Isochronous OUT endpoints)**

0 = no effect.

1 = send an interrupt when an MDATA packet has been received and so at least one packet of the microframe data payload has been received.

- **ERR_OVFLW: Overflow Error Interrupt Enabled**

0 = Overflow Error Interrupt is masked.

1 = Overflow Error Interrupt is enabled.

- **RX_BK_RDY: Received OUT Data Interrupt Enabled**

0 = Received OUT Data Interrupt is masked.

1 = Received OUT Data Interrupt is enabled.

- **TX_COMPLT: Transmitted IN Data Complete Interrupt Enabled**

0 = Transmitted IN Data Complete Interrupt is masked.

1 = Transmitted IN Data Complete Interrupt is enabled.

- **TX_PK_RDY/ERR_TRANS: TX Packet Ready/Transaction Error Interrupt Enabled**

0 = TX Packet Ready/Transaction Error Interrupt is masked.

1 = TX Packet Ready/Transaction Error Interrupt is enabled.

Caution: Interrupt source is active as long as the corresponding EPTSTAx register TX_PK_RDY flag remains low. If there are no more banks available for transmitting after the software has set EPTSTAx/TX_PK_RDY for the last transmit packet, then the interrupt source remains inactive until the first bank becomes free again to transmit at EPTSTAx/TX_PK_RDY hardware clear.

- **RX_SETUP/ERR_FL_ISO: Received SETUP/Error Flow Interrupt Enabled**

0 = Received SETUP/Error Flow Interrupt is masked.

1 = Received SETUP/Error Flow Interrupt is enabled.

- **STALL_SNT/ERR_CRISO/ERR_NBTRA: Stall Sent/ISO CRC Error/Number of Transaction Error Interrupt Enabled**

0 = Stall Sent/ISO CRC error/number of Transaction Error Interrupt is masked.

1 = Stall Sent /ISO CRC error/number of Transaction Error Interrupt is enabled.

- **NAK_IN/ERR_FLUSH: NAKIN/Bank Flush Error Interrupt Enabled**

0 = NAKIN Interrupt is masked.

1 = NAKIN/Bank Flush Error Interrupt is enabled.

- **NAK_OUT: NAKOUT Interrupt Enabled**

0 = NAKOUT Interrupt is masked.

1 = NAKOUT Interrupt is enabled.

- **BUSY_BANK: Busy Bank Interrupt Enabled**

0 = BUSY_BANK Interrupt is masked.

1 = BUSY_BANK Interrupt is enabled.

For OUT endpoints: an interrupt is sent when all banks are busy.

For IN endpoints: an interrupt is sent when all banks are free.

- **SHRT_PCKT: Short Packet Interrupt Enabled**

For OUT endpoints: send an Interrupt when a Short Packet has been received.

0 = Short Packet Interrupt is masked.

1 = Short Packet Interrupt is enabled.

For IN endpoints: a Short Packet transmission is guaranteed upon end of the DMA Transfer, thus signaling a BULK or INTERRUPT end of transfer or an end of isochronous (micro-)frame data, but only if the DMACONTROLx register END_B_EN and EPTCTLx register AUTO_VALID bits are also set.

32.6.21 USBA Endpoint Set Status Register

Name: EPTSETSTAx

Access Type: Write-only

31	30	29	28	27	26	25	24
–	–	–	–	–	–	–	–
23	22	21	20	19	18	17	16
–	–	–	–	–	–	–	–
15	14	13	12	11	10	9	8
–	–	–	–	TX_PK_RDY	–	KILL_BANK	–
7	6	5	4	3	2	1	0
–	–	FRCESTALL	–	–	–	–	–

- **FRCESTALL: Stall Handshake Request Set**

0 = no effect.

1 = set this bit to request a STALL answer to the host for the next handshake

Refer to chapters 8.4.5 (Handshake Packets) and 9.4.5 (Get Status) of the *Universal Serial Bus Specification, Rev 2.0* for more information on the STALL handshake.

- **KILL_BANK: KILL Bank Set (for IN Endpoint)**

0 = no effect.

1 = kill the last written bank.

- **TX_PK_RDY: TX Packet Ready Set**

0 = no effect.

1 = set this bit after a packet has been written into the endpoint FIFO for IN data transfers

- This flag is used to generate a Data IN transaction (device to host).
- Device firmware checks that it can write a data payload in the FIFO, checking that TX_PK_RDY is cleared.
- Transfer to the FIFO is done by writing in the “Buffer Address” register.
- Once the data payload has been transferred to the FIFO, the firmware notifies the USBA device setting TX_PK_RDY to one.
- USBA bus transactions can start.
- TXCOMP is set once the data payload has been received by the host.
- Data should be written into the endpoint FIFO only after this bit has been cleared.
- Set this bit without writing data to the endpoint FIFO to send a Zero Length Packet.

32.6.22 USBA Endpoint Clear Status Register

Name: EPTCLRSTAx

Access Type: Write-only

31	30	29	28	27	26	25	24
–	–	–	–	–	–	–	–
23	22	21	20	19	18	17	16
–	–	–	–	–	–	–	–
15	14	13	12	11	10	9	8
NAK_OUT	NAK_IN/ ERR_FLUSH	STALL_SNT/ ERR_NBTRA	RX_SETUP/ ERR_FL_ISO	–	TX_COMPLT	RX_BK_RDY	–
7	6	5	4	3	2	1	0
–	TOGGLESQ	FRCESTALL	–	–	–	–	–

- **FRCESTALL: Stall Handshake Request Clear**

0 = no effect.

1 = clear the STALL request. The next packets from host will not be STALLED.

- **TOGGLESQ: Data Toggle Clear**

0 = no effect.

1 = clear the PID data of the current bank

For OUT endpoints, the next received packet should be a DATA0.

For IN endpoints, the next packet will be sent with a DATA0 PID.

- **RX_BK_RDY: Received OUT Data Clear**

0 = no effect.

1 = clear the RX_BK_RDY flag of EPTSTAx.

- **TX_COMPLT: Transmitted IN Data Complete Clear**

0 = no effect.

1 = clear the TX_COMPLT flag of EPTSTAx.

- **RX_SETUP/ERR_FL_ISO: Received SETUP/Error Flow Clear**

0 = no effect.

1 = clear the RX_SETUP/ERR_FL_ISO flags of EPTSTAx.

- **STALL_SNT/ERR_NBTRA: Stall Sent/Number of Transaction Error Clear**

0 = no effect.

1 = clear the STALL_SNT/ERR_NBTRA flags of EPTSTAx.

- **NAK_IN/ERR_FLUSH: NAKIN/Bank Flush Error Clear**

0 = no effect.

1 = clear the NAK_IN/ERR_FLUSH flags of EPTSTAx.

- **NAK_OUT: NAKOUT Clear**

0 = no effect.

1 = clear the NAK_OUT flag of EPTSTAx.

32.6.23 USBA Endpoint Status Register

Name: EPTSTAx

Access Type: Read-only

31	30	29	28	27	26	25	24
SHRT_PCKT		BYTE_COUNT					
23	22	21	20	19	18	17	16
BYTE_COUNT				BUSY_BANK_STA		CURRENT_BANK/ CONTROL_DIR	
15	14	13	12	11	10	9	8
NAK_OUT	NAK_IN/ ERR_FLUSH	STALL_SNT/ ERR_CRISO/ ERR_NBTRA	RX_SETUP/ ERR_FL_ISO	TX_PK_RDY/ ERR_TRANS	TX_COMPLT	RX_BK_RDY/ KILL_BANK	ERR_OVFLW
7	6	5	4	3	2	1	0
TOGGLESQ_STA		FRCESTALL	-	-	-	-	-

- **FRCESTALL: Stall Handshake Request**

0 = no effect.

1= If set a STALL answer will be done to the host for the next handshake.

This bit is reset by hardware upon received SETUP.

- **TOGGLESQ_STA: Toggle Sequencing**

Toggle Sequencing:

IN endpoint: it indicates the PID Data Toggle that will be used for the next packet sent. This is not relative to the current bank.

CONTROL and OUT endpoint:

These bits are set by hardware to indicate the PID data of the current bank:

00	Data0
01	Data1
10	Data2 (only for High Bandwidth Isochronous Endpoint)
11	MData (only for High Bandwidth Isochronous Endpoint)

Note 1: In OUT transfer, the Toggle information is meaningful only when the current bank is busy (Received OUT Data = 1).

Note 2: These bits are updated for OUT transfer:

- a new data has been written into the current bank.
- the user has just cleared the Received OUT Data bit to switch to the next bank.

Note 3: For High Bandwidth Isochronous Out endpoint, it is recommended to check the EPTSTAx/ERR_TRANS bit to know if the toggle sequencing is correct or not.

Note 4: This field is reset to DATA1 by the EPTCLRSTAx register TOGGLESQ bit, and by EPTCTLDISx (disable endpoint).

- **ERR_OVFLW: Overflow Error**

This bit is set by hardware when a new too-long packet is received.

Example: If the user programs an endpoint 64 bytes wide and the host sends 128 bytes in an OUT transfer, then the Overflow Error bit is set.

This bit is updated at the same time as the BYTE_COUNT field.

This bit is reset by EPTRST register RST_EPT_x (reset endpoint) and by EPTCTLDISx (disable endpoint).

- **RX_BK_RDY/KILL_BANK: Received OUT Data/KILL Bank**

Received OUT Data: (For OUT endpoint or Control endpoint)

This bit is set by hardware after a new packet has been stored in the endpoint FIFO.

This bit is cleared by the device firmware after reading the OUT data from the endpoint.

For multi-bank endpoints, this bit may remain active even when cleared by the device firmware, this if an other packet has been received meanwhile.

Hardware assertion of this bit may generate an interrupt if enabled by the EPTCTLx register RX_BK_RDY bit.

This bit is reset by EPTRST register RST_EPT_x (reset endpoint) and by EPTCTLDISx (disable endpoint).

KILL Bank: (For IN endpoint)

- the bank is really cleared or the bank is sent, BUSY_BANK_STA is decremented.
- the bank is not cleared but sent on the IN transfer, TX_COMPLT
- the bank is not cleared because it was empty. The user should wait that this bit is cleared before trying to clear another packet.

Note: “Kill a packet” may be refused if at the same time, an IN token is coming and the current packet is sent on the USB line. In this case, the TX_COMPLT bit is set. Take notice however, that if at least two banks are ready to be sent, there is no problem to kill a packet even if an IN token is coming. In fact, in that case, the current bank is sent (IN transfer) and the last bank is killed.

- **TX_COMPLT: Transmitted IN Data Complete**

This bit is set by hardware after an IN packet has been transmitted for isochronous endpoints and after it has been accepted (ACK’ed) by the host for Control, Bulk and Interrupt endpoints.

This bit is reset by EPTRST register RST_EPT_x (reset endpoint), and by EPTCTLDISx (disable endpoint).

- **TX_PK_RDY/ERR_TRANS: TX Packet Ready/Transaction Error**

TX Packet Ready:

This bit is cleared by hardware, as soon as the packet has been sent for isochronous endpoints, or after the host has acknowledged the packet for Control, Bulk and Interrupt endpoints.

For Multi-bank endpoints, this bit may remain clear even after software is set if another bank is available to transmit.

Hardware clear of this bit may generate an interrupt if enabled by the EPTCTLx register TX_PK_RDY bit.

This bit is reset by EPTRST register RST_EPT_x (reset endpoint), and by EPTCTLDISx (disable endpoint).

Transaction Error: (For high bandwidth isochronous OUT endpoints) (Read-Only)

This bit is set by hardware when a transaction error occurs inside one microframe.

If one toggle sequencing problem occurs among the n-transactions (n = 1, 2 or 3) inside a microframe, then this bit is still set as long as the current bank contains one “bad” n-transaction. (see ["CURRENT_BANK/CONTROL_DIR: Current](#)

[Bank/Control Direction” on page 658](#)) As soon as the current bank is relative to a new “good” n-transactions, then this bit is reset.

Note1: A transaction error occurs when the toggle sequencing does not respect the *Universal Serial Bus Specification, Rev 2.0* (5.9.2 High Bandwidth Isochronous endpoints) (Bad PID, missing data....)

Note2: When a transaction error occurs, the user may empty all the “bad” transactions by clearing the Received OUT Data flag (RX_BK_RDY).

If this bit is reset, then the user should consider that a new n-transaction is coming.

This bit is reset by EPTRST register RST_EPT_x (reset endpoint), and by EPTCTLDISx (disable endpoint).

- **RX_SETUP/ERR_FL_ISO: Received SETUP/Error Flow**

Received SETUP: (for Control endpoint only)

This bit is set by hardware when a valid SETUP packet has been received from the host.

It is cleared by the device firmware after reading the SETUP data from the endpoint FIFO.

This bit is reset by EPTRST register RST_EPT_x (reset endpoint), and by EPTCTLDISx (disable endpoint).

Error Flow: (for isochronous endpoint only)

This bit is set by hardware when a transaction error occurs.

- Isochronous IN transaction is missed, the micro has no time to fill the endpoint (underflow).
- Isochronous OUT data is dropped because the bank is busy (overflow).

This bit is reset by EPTRST register RST_EPT_x (reset endpoint) and by EPTCTLDISx (disable endpoint).

- **STALL_SNT/ERR_CRISO/ERR_NBTRA: Stall Sent/CRC ISO Error/Number of Transaction Error**

STALL_SNT: (for Control, Bulk and Interrupt endpoints)

This bit is set by hardware after a STALL handshake has been sent as requested by the EPTSTAx register FRCESTALL bit.

This bit is reset by EPTRST register RST_EPT_x (reset endpoint) and by EPTCTLDISx (disable endpoint).

ERR_CRISO: (for Isochronous OUT endpoints) (Read-only)

This bit is set by hardware if the last received data is corrupted (CRC error on data).

This bit is updated by hardware when new data is received (Received OUT Data bit).

ERR_NBTRA: (for High Bandwidth Isochronous IN endpoints)

This bit is set at the end of a microframe in which at least one data bank has been transmitted, if less than the number of transactions per micro-frame banks (EPTCFGx register NB_TRANS) have been validated for transmission inside this microframe.

This bit is reset by EPTRST register RST_EPT_x (reset endpoint) and by EPTCTLDISx (disable endpoint).

- **NAK_IN/ERR_FLUSH: NAK IN/Bank Flush Error**

NAK_IN:

This bit is set by hardware when a NAK handshake has been sent in response to an IN request from the Host.

This bit is cleared by software.

ERR_FLUSH: (for High Bandwidth Isochronous IN endpoints)

This bit is set when flushing unsent banks at the end of a microframe.

This bit is reset by EPTRST register RST_EPT_x (reset endpoint) and by EPT_CTL_DISx (disable endpoint).

• **NAK_OUT: NAK OUT**

This bit is set by hardware when a NAK handshake has been sent in response to an OUT or PING request from the Host.

This bit is reset by EPTRST register RST_EPT_x (reset endpoint) and by EPT_CTL_DISx (disable endpoint).

• **CURRENT_BANK/CONTROL_DIR: Current Bank/Control Direction**

Current Bank: (all endpoints except Control endpoint)

These bits are set by hardware to indicate the number of the current bank.

00	Bank 0 (or single bank)
01	Bank 1
10	Bank 2
11	Invalid

Note: the current bank is updated each time the user:

- Sets the TX Packet Ready bit to prepare the next IN transfer and to switch to the next bank.
- Clears the received OUT data bit to access the next bank.

This bit is reset by EPTRST register RST_EPT_x (reset endpoint) and by EPTCTLDISx (disable endpoint).

Control Direction: (for Control endpoint only)

0 = a Control Write is requested by the Host.

1 = a Control Read is requested by the Host.

Note1: This bit corresponds with the 7th bit of the bmRequestType (Byte 0 of the Setup Data).

Note2: This bit is updated after receiving new setup data.

• **BUSY_BANK_STA: Busy Bank Number**

These bits are set by hardware to indicate the number of busy banks.

IN endpoint: it indicates the number of busy banks filled by the user, ready for IN transfer.

OUT endpoint: it indicates the number of busy banks filled by OUT transaction from the Host.

00	All banks are free
01	1 busy bank
10	2 busy banks
11	3 busy banks

• **BYTE_COUNT: USBA Byte Count**

Byte count of a received data packet.

This field is incremented after each write into the endpoint (to prepare an IN transfer).

This field is decremented after each reading into the endpoint (OUT transfer).

This field is also updated at RX_BK_RDY flag clear with the next bank.

This field is also updated at TX_PK_RDY flag set with the next bank.

This field is reset by RST_EPT_x of EPTRST register.

- **SHRT_PCKT: Short Packet**

An OUT Short Packet is detected when the receive byte count is less than the configured EPTCFGx register EPT_Size.

This bit is updated at the same time as the BYTE_COUNT field.

This bit is reset by EPTRST register RST_EPT_x (reset endpoint) and by EPTCTLDISx (disable endpoint).

32.6.24 USB DMA Channel Transfer Descriptor

The DMA channel transfer descriptor is loaded from the memory.

Be careful with the alignment of this buffer.

The structure of the DMA channel transfer descriptor is defined by three parameters as described below:

Offset 0:

The address must be aligned: 0xXXXX0

Next Descriptor Address Register: DMANXTDSCx

Offset 4:

The address must be aligned: 0xXXXX4

DMA Channelx Address Register: DMAADDRESSx

Offset 8:

The address must be aligned: 0xXXXX8

DMA Channelx Control Register: DMACONTROLx

To use the DMA channel transfer descriptor, fill the structures with the correct value (as described in the following pages).

Then write directly in DMANXTDSCx the address of the descriptor to be used first.

Then write 1 in the LDNXT_DSC bit of DMACONTROLx (load next channel transfer descriptor). The descriptor is automatically loaded upon Endpointx request for packet transfer.

32.6.25 USBA DMA Next Descriptor Address Register

Name: DMANXTDSCx

Access Type: Read/Write

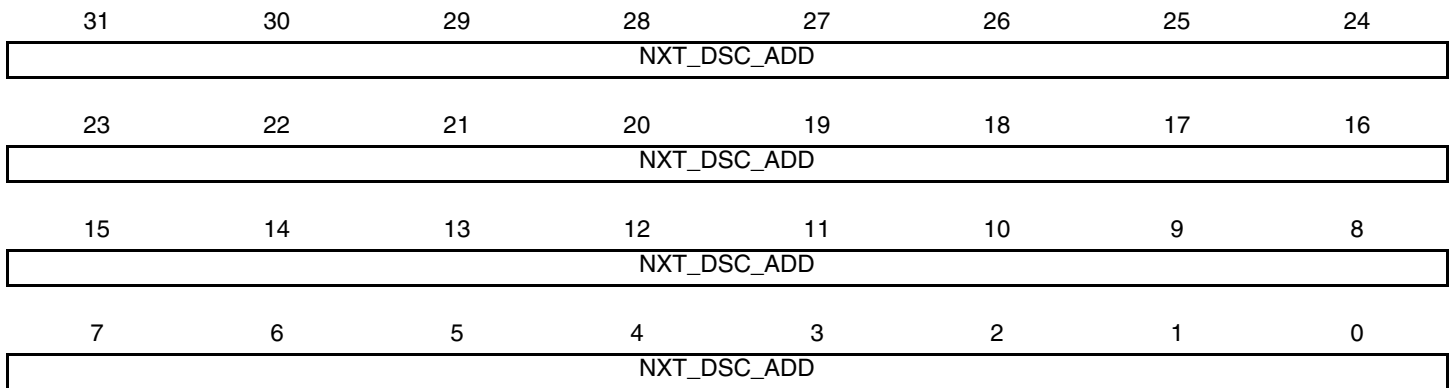

• **NXT_DSC_ADD**

This field points to the next channel descriptor to be processed. This channel descriptor must be aligned, so bits 0 to 3 of the address must be equal to zero.

32.6.26 USBA DMA Channelx Address Register

Name: DMAADDRESSx

Access Type: Read/Write

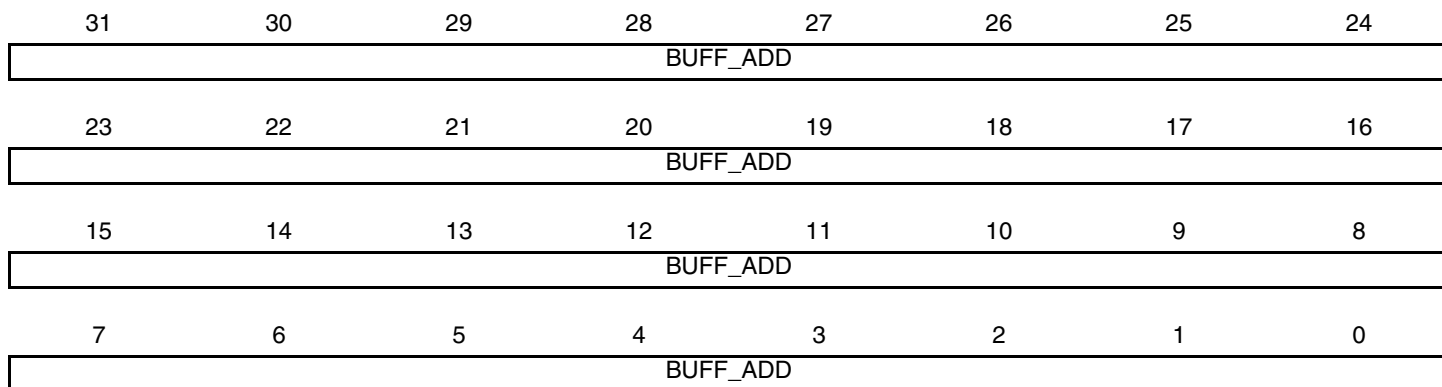

- **BUFF_ADD**

This field determines the HSB bus starting address of a DMA channel transfer.

Channel start and end addresses may be aligned on any byte boundary.

The firmware may write this field only when the DMASTATUS register CHANN_ENB bit is clear.

This field is updated at the end of the address phase of the current access to the HSB bus. It is incrementing of the access byte width. The access width is 4 bytes (or less) at packet start or end, if the start or end address is not aligned on a word boundary.

The packet start address is either the channel start address or the next channel address to be accessed in the channel buffer.

The packet end address is either the channel end address or the latest channel address accessed in the channel buffer.

The channel start address is written by software or loaded from the descriptor, whereas the channel end address is either determined by the end of buffer or the USBA device, USB end of transfer if the DMACONTROLx register END_TR_EN bit is set.

32.6.27 USBA DMA Channelx Control Register

Name: DMACONTROLx

Access Type: Read/Write

31	30	29	28	27	26	25	24
BUFF_LENGTH							
23	22	21	20	19	18	17	16
BUFF_LENGTH							
15	14	13	12	11	10	9	8
-	-	-	-	-	-	-	-
7	6	5	4	3	2	1	0
BURST_LCK	DESC_LD_IT	END_BUFFIT	END_TR_IT	END_B_EN	END_TR_EN	LDNXT_DSC	CHANN_ENB

- **CHANN_ENB (Channel Enable Command)**

0 = DMA channel is disabled at and no transfer will occur upon request. This bit is also cleared by hardware when the channel source bus is disabled at end of buffer.

If the DMACONTROL register LDNXT_DSC bit has been cleared by descriptor loading, the firmware will have to set the corresponding CHANN_ENB bit to start the described transfer, if needed.

If the DMACONTROL register LDNXT_DSC bit is cleared, the channel is frozen and the channel registers may then be read and/or written reliably as soon as both DMASTATUS register CHANN_ENB and CHANN_ACT flags read as 0.

If a channel request is currently serviced when this bit is cleared, the DMA FIFO buffer is drained until it is empty, then the DMASTATUS register CHANN_ENB bit is cleared.

If the LDNXT_DSC bit is set at or after this bit clearing, then the currently loaded descriptor is skipped (no data transfer occurs) and the next descriptor is immediately loaded.

1 = DMASTATUS register CHANN_ENB bit will be set, thus enabling DMA channel data transfer. Then any pending request will start the transfer. This may be used to start or resume any requested transfer.

- **LDNXT_DSC: Load Next Channel Transfer Descriptor Enable (Command)**

0 = no channel register is loaded after the end of the channel transfer.

1 = the channel controller loads the next descriptor after the end of the current transfer, i.e. when the DMASTATUS/CHANN_ENB bit is reset.

If the DMA CONTROL/CHANN_ENB bit is cleared, the next descriptor is immediately loaded upon transfer request.

DMA Channel Control Command Summary

LDNXT_DSC	CHANN_ENB	Description
0	0	Stop now
0	1	Run and stop at end of buffer
1	0	Load next descriptor now
1	1	Run and link at end of buffer

- **END_TR_EN: End of Transfer Enable (Control)**

Used for OUT transfers only.

0 = USB end of transfer is ignored.

1 = USBA device can put an end to the current buffer transfer.

When set, a BULK or INTERRUPT short packet or the last packet of an ISOCHRONOUS (micro) frame (DATAx) will close the current buffer and the DMASTATUSx register END_TR_ST flag will be raised.

This is intended for USBA non-prenegotiated end of transfer (BULK or INTERRUPT) or ISOCHRONOUS microframe data buffer closure.

- **END_B_EN: End of Buffer Enable (Control)**

0 = DMA Buffer End has no impact on USB packet transfer.

1 = endpoint can validate the packet (according to the values programmed in the EPTCTLx register AUTO_VALID and SHRT_PCKT fields) at DMA Buffer End, i.e. when the DMASTATUS register BUFF_COUNT reaches 0.

This is mainly for short packet IN validation initiated by the DMA reaching end of buffer, but could be used for OUT packet truncation (discarding of unwanted packet data) at the end of DMA buffer.

- **END_TR_IT: End of Transfer Interrupt Enable**

0 = USBA device initiated buffer transfer completion will not trigger any interrupt at STATUSx/END_TR_ST rising.

1 = an interrupt is sent after the buffer transfer is complete, if the USBA device has ended the buffer transfer.

Use when the receive size is unknown.

- **END_BUFFIT: End of Buffer Interrupt Enable**

0 = DMA_STATUSx/END_BF_ST rising will not trigger any interrupt.

1 = an interrupt is generated when the DMASTATUSx register BUFF_COUNT reaches zero.

- **DESC_LD_IT: Descriptor Loaded Interrupt Enable**

0 = DMASTATUSx/DESC_LDST rising will not trigger any interrupt.

1 = an interrupt is generated when a descriptor has been loaded from the bus.

- **BURST_LCK: Burst Lock Enable**

0 = the DMA never locks bus access.

1 = USB packets HSB data bursts are locked for maximum optimization of the bus bandwidth usage and maximization of fly-by HSB burst duration.

- **BUFF_LENGTH: Buffer Byte Length (Write-only)**

This field determines the number of bytes to be transferred until end of buffer. The maximum channel transfer size (64 KB) is reached when this field is 0 (default value). If the transfer size is unknown, this field should be set to 0, but the transfer end may occur earlier under USBA device control.

When this field is written, The DMASTATUSx register BUFF_COUNT field is updated with the write value.

Note: Bits [31:2] are only writable when issuing a channel Control Command other than "Stop Now".

Note: For reliability it is highly recommended to wait for both DMASTATUSx register CHAN_ACT and CHAN_ENB flags are at 0, thus ensuring the channel has been stopped before issuing a command other than "Stop Now".

32.6.28 USB DMA Channelx Status Register

Name: DMASTATUSx

Access Type: Read/Write

31	30	29	28	27	26	25	24
BUFF_COUNT							
23	22	21	20	19	18	17	16
BUFF_COUNT							
15	14	13	12	11	10	9	8
-	-	-	-	-	-	-	-
7	6	5	4	3	2	1	0
-	DESC_LDST	END_BF_ST	END_TR_ST	-	-	CHANN_ACT	CHANN_ENB

- **CHANN_ENB: Channel Enable Status**

0 = if cleared, the DMA channel no longer transfers data, and may load the next descriptor if the DMACONTROLx register LDNXT_DSC bit is set.

When any transfer is ended either due to an elapsed byte count or a USBA device initiated transfer end, this bit is automatically reset.

1 = if set, the DMA channel is currently enabled and transfers data upon request.

This bit is normally set or cleared by writing into the DMACONTROLx register CHANN_ENB bit field either by software or descriptor loading.

If a channel request is currently serviced when the DMACONTROLx register CHANN_ENB bit is cleared, the DMA FIFO buffer is drained until it is empty, then this status bit is cleared.

- **CHANN_ACT: Channel Active Status**

0 = the DMA channel is no longer trying to source the packet data.

When a packet transfer is ended this bit is automatically reset.

1 = the DMA channel is currently trying to source packet data, i.e. selected as the highest-priority requesting channel.

When a packet transfer cannot be completed due to an END_BF_ST, this flag stays set during the next channel descriptor load (if any) and potentially until USBA packet transfer completion, if allowed by the new descriptor.

- **END_TR_ST: End of Channel Transfer Status**

0 = cleared automatically when read by software.

1 = set by hardware when the last packet transfer is complete, if the USBA device has ended the transfer.

Valid until the CHANN_ENB flag is cleared at the end of the next buffer transfer.

- **END_BF_ST: End of Channel Buffer Status**

0 = cleared automatically when read by software.

1 = set by hardware when the BUFF_COUNT downcount reach zero.

Valid until the CHANN_ENB flag is cleared at the end of the next buffer transfer.

- **DESC_LDST: Descriptor Loaded Status**

0 = cleared automatically when read by software.

1 = set by hardware when a descriptor has been loaded from the system bus.

Valid until the CHANN_ENB flag is cleared at the end of the next buffer transfer.

- **BUFF_COUNT: Buffer Byte Count**

This field determines the current number of bytes still to be transferred for this buffer.

This field is decremented from the HSB source bus access byte width at the end of this bus address phase.

The access byte width is 4 by default, or less, at DMA start or end, if the start or end address is not aligned on a word boundary.

At the end of buffer, the DMA accesses the USBA device only for the number of bytes needed to complete it.

This field value is reliable (stable) only if the channel has been stopped or frozen (EPTCTLx register NT_DIS_DMA bit is used to disable the channel request) and the channel is no longer active CHANN_ACT flag is 0.

Note: For OUT endpoints, if the receive buffer byte length (BUFF_LENGTH) has been defaulted to zero because the USB transfer length is unknown, the actual buffer byte length received will be 0x10000-BUFF_COUNT.

33. Timer/Counter (TC)

Rev: 6082C

33.1 Features

- **Three 16-bit Timer Counter Channels**
- **A Wide Range of Functions Including:**
 - Frequency Measurement
 - Event Counting
 - Interval Measurement
 - Pulse Generation
 - Delay Timing
 - Pulse Width Modulation
 - Up/down Capabilities
- **Each Channel is User-configurable and Contains:**
 - Three External Clock Inputs
 - Five Internal Clock Inputs
 - Two Multi-purpose Input/Output Signals
- **Internal Interrupt Signal**
- **Two Global Registers that Act on All Three TC Channels**

33.2 Description

The Timer Counter (TC) includes three identical 16-bit Timer Counter channels.

Each channel can be independently programmed to perform a wide range of functions including frequency measurement, event counting, interval measurement, pulse generation, delay timing and pulse width modulation.

Each channel has three external clock inputs, five internal clock inputs and two multi-purpose input/output signals which can be configured by the user. Each channel drives an internal interrupt signal which can be programmed to generate processor interrupts.

The Timer Counter block has two global registers which act upon all three TC channels.

The Block Control Register allows the three channels to be started simultaneously with the same instruction.

The Block Mode Register defines the external clock inputs for each channel, allowing them to be chained.

33.3 Block Diagram

Figure 33-1. Timer Counter Block Diagram

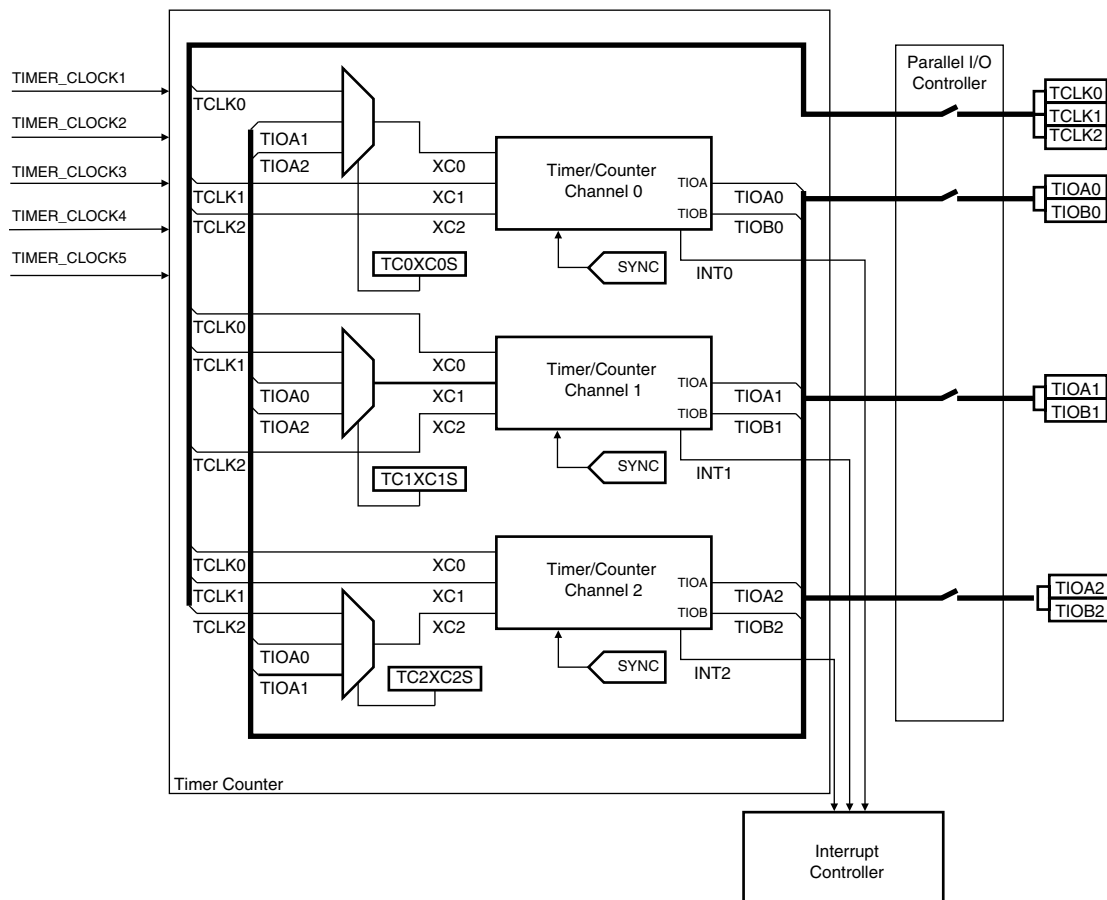

Table 33-1. Signal Name Description

Block/Channel	Signal Name	Description
Channel Signal	XC0, XC1, XC2	External Clock Inputs
	TIOA	Capture Mode: Timer Counter Input Waveform Mode: Timer Counter Output
	TIOB	Capture Mode: Timer Counter Input Waveform Mode: Timer Counter Input/Output
	INT	Interrupt Signal Output
	SYNC	Synchronization Input Signal

33.4 Pin Name List

Table 33-2. TC pin list

Pin Name	Description	Type
TCLK0-TCLK2	External Clock Input	Input
TIOA0-TIOA2	I/O Line A	I/O
TIOB0-TIOB2	I/O Line B	I/O

33.5 Product Dependencies

33.5.1 I/O Lines

The pins used for interfacing the compliant external devices may be multiplexed with PIO lines. The programmer must first program the PIO controllers to assign the TC pins to their peripheral functions.

33.5.2 Power Management

The Timer Counter clock is generated by the power manager. Before using the TC, the programmer must ensure that the TC clock is enabled in the power manager.

33.5.3 Interrupt

The TC has an interrupt line connected to the interrupt controller. Handling the TC interrupt requires programming the interrupt controller before configuring the TC.

33.6 Functional Description

33.6.1 TC Description

The three channels of the Timer Counter are independent and identical in operation. The registers for channel programming are listed in [Table 33-4 on page 682](#).

33.6.1.1 16-bit Counter

Each channel is organized around a 16-bit counter. The value of the counter is incremented at each positive edge of the selected clock. When the counter has reached the value 0xFFFF and passes to 0x0000, an overflow occurs and the COVFS bit in SR (Status Register) is set.

The current value of the counter is accessible in real time by reading the Counter Value Register, CV. The counter can be reset by a trigger. In this case, the counter value passes to 0x0000 on the next valid edge of the selected clock.

33.6.1.2 Clock Selection

At block level, input clock signals of each channel can either be connected to the external inputs TCLK0, TCLK1 or TCLK2, or be connected to the configurable I/O signals TIOA0, TIOA1 or TIOA2 for chaining by programming the BMR (Block Mode). See [Figure 33-2](#).

Each channel can independently select an internal or external clock source for its counter:

- Internal clock signals: TIMER_CLOCK1, TIMER_CLOCK2, TIMER_CLOCK3, TIMER_CLOCK4, TIMER_CLOCK5. The Peripherals Chapter details the connection of these clock sources.
- External clock signals: XC0, XC1 or XC2. The Peripherals Chapter details the connection of these clock sources.

This selection is made by the TCCLKS bits in the TC Channel Mode Register .

The selected clock can be inverted with the CLKI bit in CMR. This allows counting on the opposite edges of the clock.

The burst function allows the clock to be validated when an external signal is high. The BURST parameter in the Mode Register defines this signal (none, XC0, XC1, XC2).

Note: In all cases, if an external clock is used, the duration of each of its levels must be longer than the master clock period. The external clock frequency must be at least 2.5 times lower than the master clock

Figure 33-2. Clock Selection

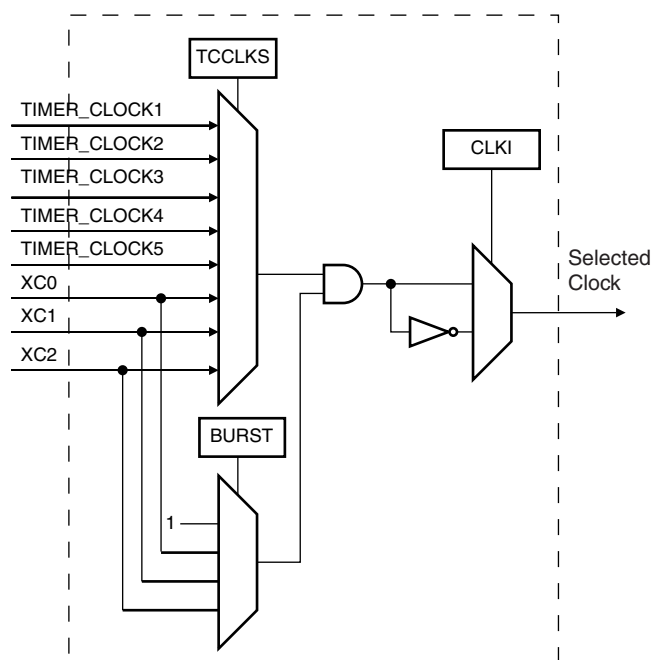

33.6.1.3 Clock Control

The clock of each counter can be controlled in two different ways: it can be enabled/disabled and started/stopped. See [Figure 33-3](#).

- The clock can be enabled or disabled by the user with the CLKEN and the CLKDIS commands in the Control Register. In Capture Mode it can be disabled by an RB load event if LDBDIS is set to 1 in CMR. In Waveform Mode, it can be disabled by an RC Compare event if CPCDIS is set to 1 in CMR. When disabled, the start or the stop actions have no effect: only a CLKEN command in the Control Register can re-enable the clock. When the clock is enabled, the CLKSTA bit is set in the Status Register.
- The clock can also be started or stopped: a trigger (software, synchro, external or compare) always starts the clock. The clock can be stopped by an RB load event in Capture Mode

(LDBSTOP = 1 in CMR) or a RC compare event in Waveform Mode (CPCSTOP = 1 in CMR). The start and the stop commands have effect only if the clock is enabled.

Figure 33-3. Clock Control

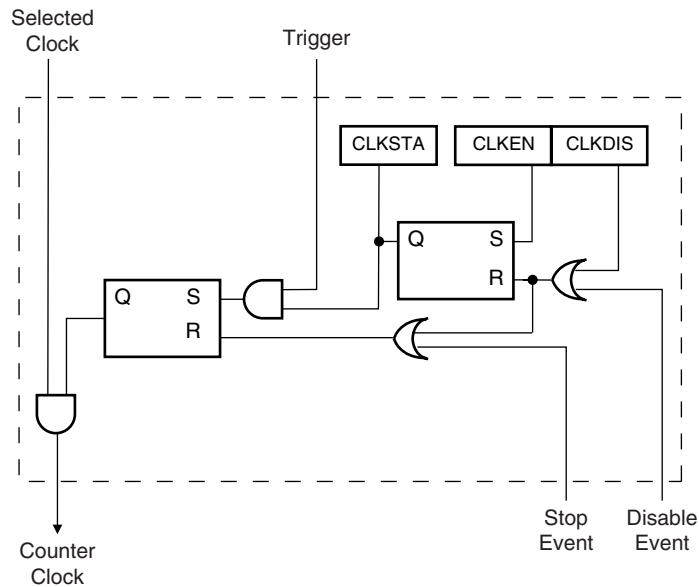

33.6.1.4 TC Operating Modes

Each channel can independently operate in two different modes:

- Capture Mode provides measurement on signals.
- Waveform Mode provides wave generation.

The TC Operating Mode is programmed with the WAVE bit in the TC Channel Mode Register.

In Capture Mode, TIOA and TIOB are configured as inputs.

In Waveform Mode, TIOA is always configured to be an output and TIOB is an output if it is not selected to be the external trigger.

33.6.1.5 Trigger

A trigger resets the counter and starts the counter clock. Three types of triggers are common to both modes, and a fourth external trigger is available to each mode.

The following triggers are common to both modes:

- Software Trigger: Each channel has a software trigger, available by setting SWTRG in CCR.
- SYNC: Each channel has a synchronization signal SYNC. When asserted, this signal has the same effect as a software trigger. The SYNC signals of all channels are asserted simultaneously by writing BCR (Block Control) with SYNC set.
- Compare RC Trigger: RC is implemented in each channel and can provide a trigger when the counter value matches the RC value if CPCTRG is set in CMR.

The channel can also be configured to have an external trigger. In Capture Mode, the external trigger signal can be selected between TIOA and TIOB. In Waveform Mode, an external event can be programmed on one of the following signals: TIOB, XC0, XC1 or XC2. This external event can then be programmed to perform a trigger by setting ENETRIG in CMR.

If an external trigger is used, the duration of the pulses must be longer than the master clock period in order to be detected.

Regardless of the trigger used, it will be taken into account at the following active edge of the selected clock. This means that the counter value can be read differently from zero just after a trigger, especially when a low frequency signal is selected as the clock.

33.6.2 Capture Operating Mode

This mode is entered by clearing the WAVE parameter in CMR (Channel Mode Register).

Capture Mode allows the TC channel to perform measurements such as pulse timing, frequency, period, duty cycle and phase on TIOA and TIOB signals which are considered as inputs.

Figure 33-4 shows the configuration of the TC channel when programmed in Capture Mode.

33.6.2.1 Capture Registers A and B

Registers A and B (RA and RB) are used as capture registers. This means that they can be loaded with the counter value when a programmable event occurs on the signal TIOA.

The LDRA parameter in CMR defines the TIOA edge for the loading of register A, and the LDRB parameter defines the TIOA edge for the loading of Register B.

RA is loaded only if it has not been loaded since the last trigger or if RB has been loaded since the last loading of RA.

RB is loaded only if RA has been loaded since the last trigger or the last loading of RB.

Loading RA or RB before the read of the last value loaded sets the Overrun Error Flag (LOVRS) in SR (Status Register). In this case, the old value is overwritten.

33.6.2.2 Trigger Conditions

In addition to the SYNC signal, the software trigger and the RC compare trigger, an external trigger can be defined.

The ABETRG bit in CMR selects TIOA or TIOB input signal as an external trigger. The ETRGEDG parameter defines the edge (rising, falling or both) detected to generate an external trigger. If ETRGEDG = 0 (none), the external trigger is disabled.

Figure 33-4. Capture Mode

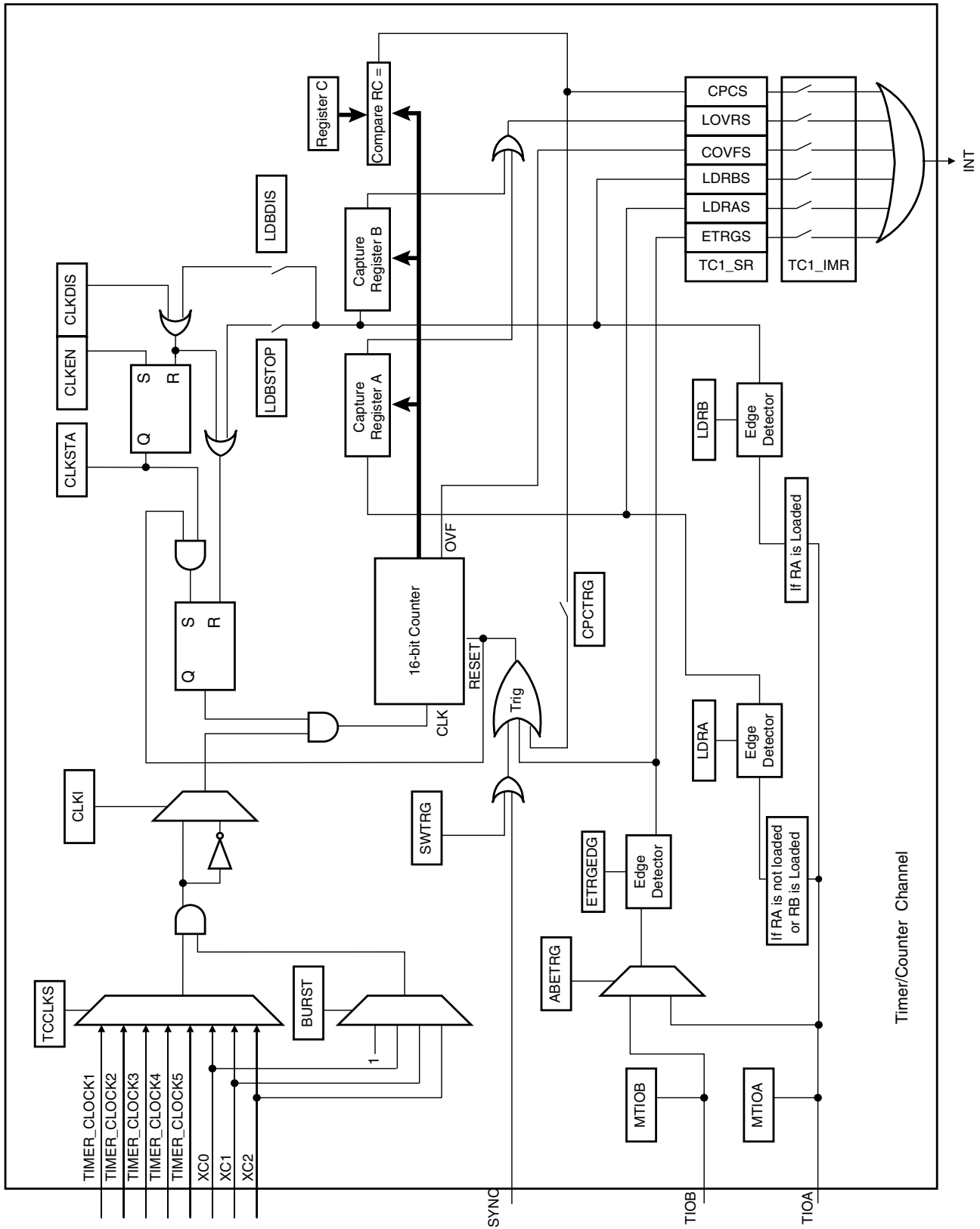

33.6.3 Waveform Operating Mode

Waveform operating mode is entered by setting the WAVE parameter in CMR (Channel Mode Register).

In Waveform Operating Mode the TC channel generates 1 or 2 PWM signals with the same frequency and independently programmable duty cycles, or generates different types of one-shot or repetitive pulses.

In this mode, TIOA is configured as an output and TIOB is defined as an output if it is not used as an external event (EEVT parameter in CMR).

Figure 33-5 shows the configuration of the TC channel when programmed in Waveform Operating Mode.

33.6.3.1 Waveform Selection

Depending on the WAVSEL parameter in CMR (Channel Mode Register), the behavior of CV varies.

With any selection, RA, RB and RC can all be used as compare registers.

RA Compare is used to control the TIOA output, RB Compare is used to control the TIOB output (if correctly configured) and RC Compare is used to control TIOA and/or TIOB outputs.

Figure 33-5. Waveform Mode

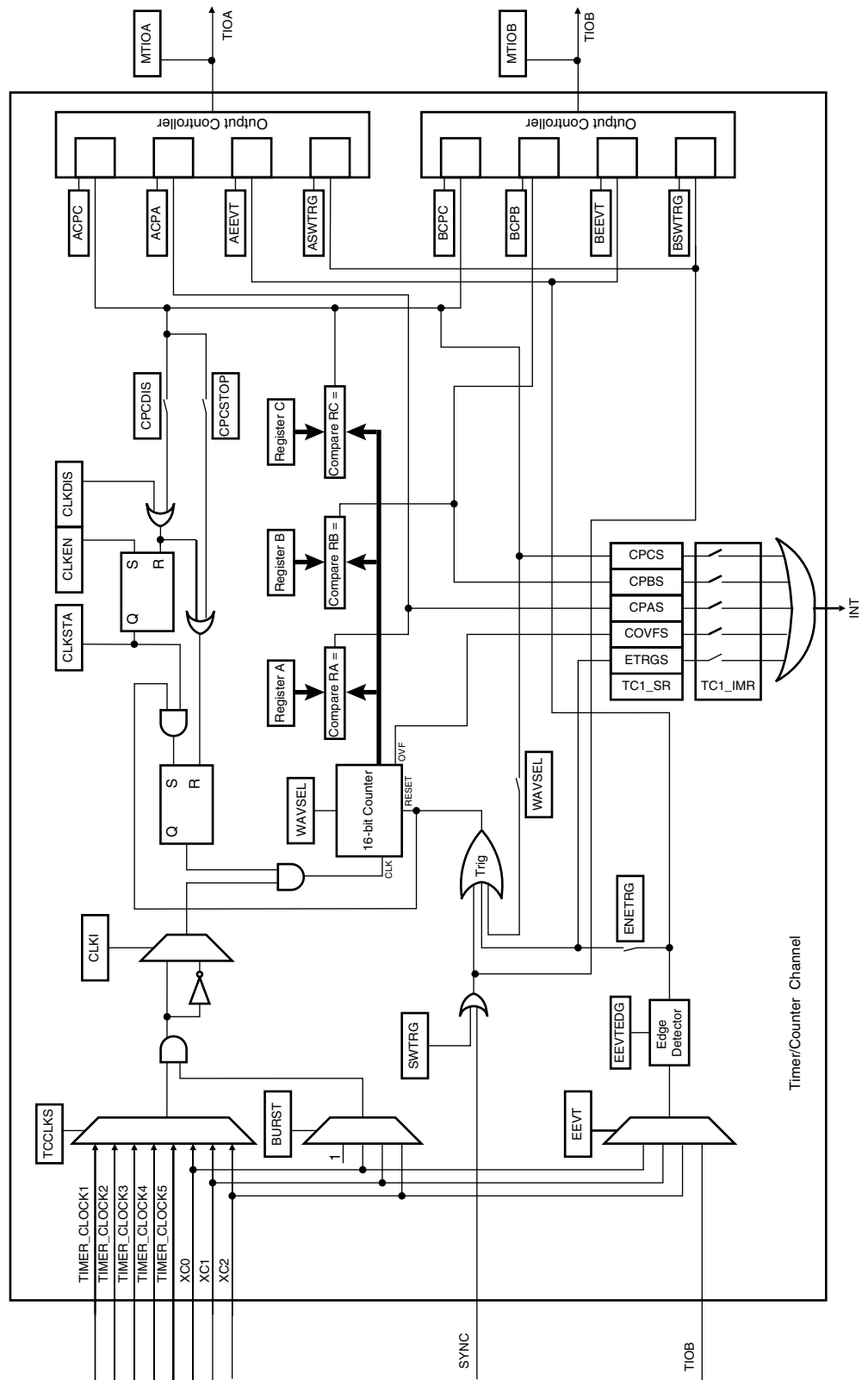

33.6.3.2 WAVSEL = 00

When WAVSEL = 00, the value of CV is incremented from 0 to 0xFFFF. Once 0xFFFF has been reached, the value of CV is reset. Incrementation of CV starts again and the cycle continues. See [Figure 33-6](#).

An external event trigger or a software trigger can reset the value of CV. It is important to note that the trigger may occur at any time. See [Figure 33-7](#).

RC Compare cannot be programmed to generate a trigger in this configuration. At the same time, RC Compare can stop the counter clock (CPCSTOP = 1 in CMR) and/or disable the counter clock (CPCDIS = 1 in CMR).

Figure 33-6. WAVSEL= 00 without trigger

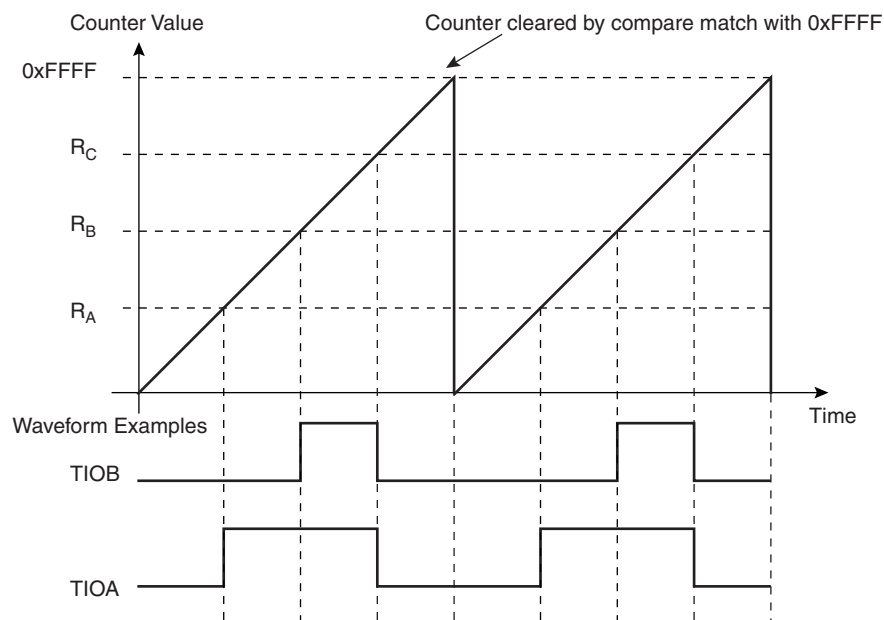
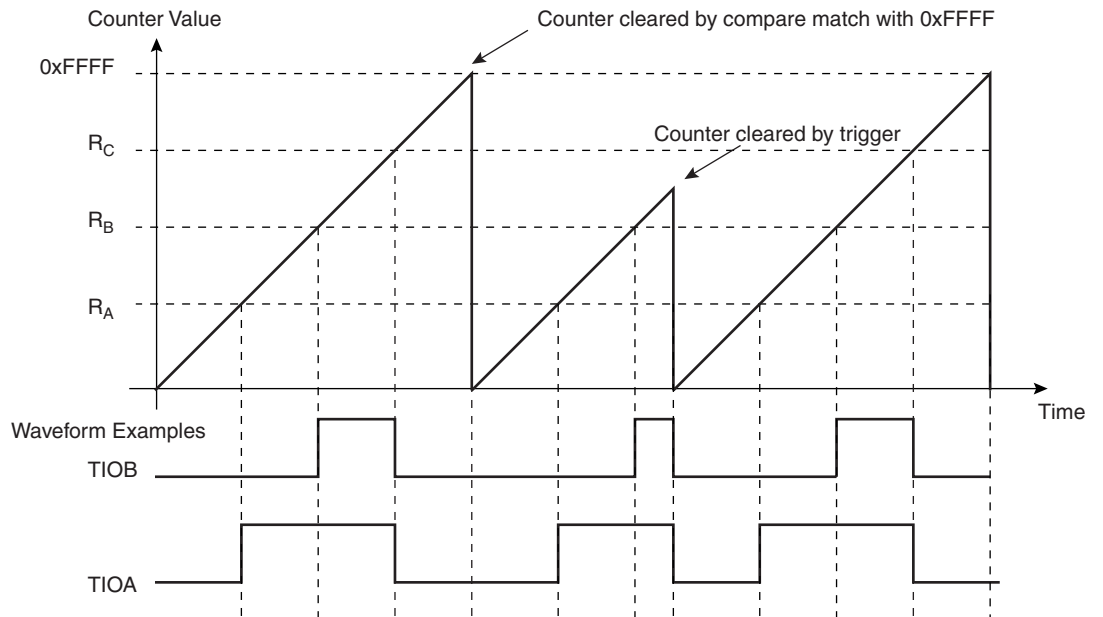

Figure 33-7. WAVSEL= 00 with trigger



33.6.3.3 WAVSEL = 10

When WAVSEL = 10, the value of CV is incremented from 0 to the value of RC, then automatically reset on a RC Compare. Once the value of CV has been reset, it is then incremented and so on. See [Figure 33-8](#).

It is important to note that CV can be reset at any time by an external event or a software trigger if both are programmed correctly. See [Figure 33-9](#).

In addition, RC Compare can stop the counter clock (CPCSTOP = 1 in CMR) and/or disable the counter clock (CPCDIS = 1 in CMR).

Figure 33-8. WAVSEL = 10 Without Trigger

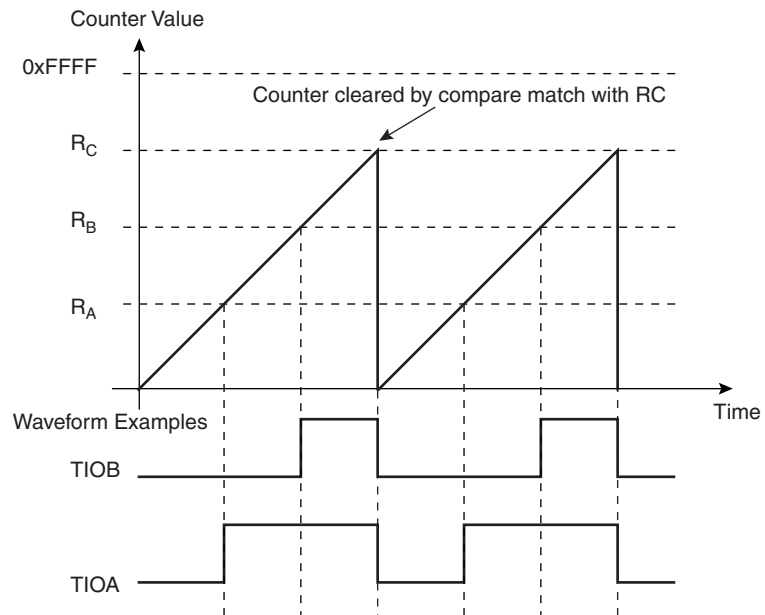
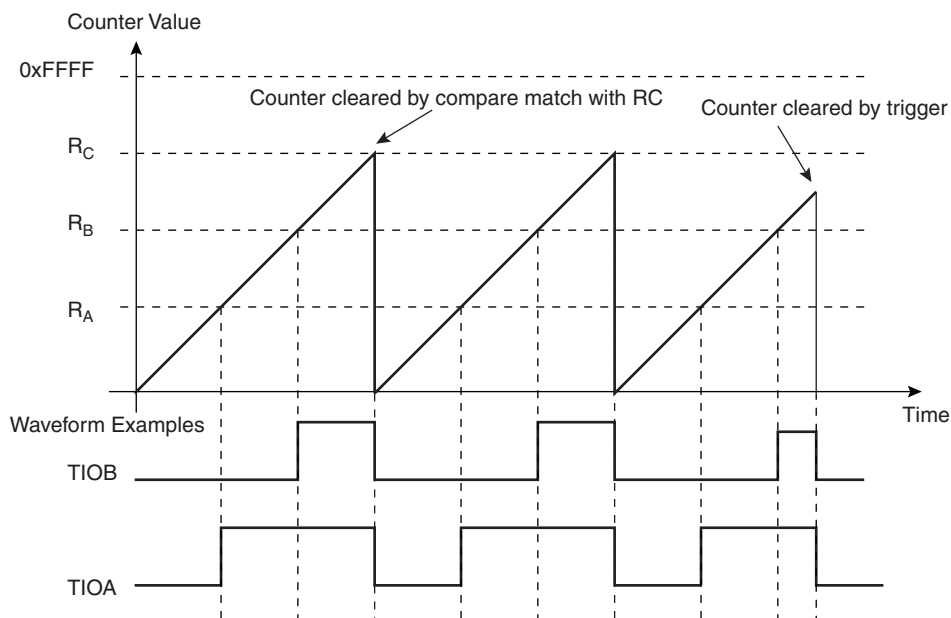

Figure 33-9. WAVSEL = 10 With Trigger



33.6.3.4 WAVSEL = 01

When WAVSEL = 01, the value of CV is incremented from 0 to 0xFFFF. Once 0xFFFF is reached, the value of CV is decremented to 0, then re-incremented to 0xFFFF and so on. See [Figure 33-10](#).

A trigger such as an external event or a software trigger can modify CV at any time. If a trigger occurs while CV is incrementing, CV then decrements. If a trigger is received while CV is decrementing, CV then increments. See [Figure 33-11](#).

RC Compare cannot be programmed to generate a trigger in this configuration.

At the same time, RC Compare can stop the counter clock (CPCSTOP = 1) and/or disable the counter clock (CPCDIS = 1).

Figure 33-10. WAVSEL = 01 Without Trigger

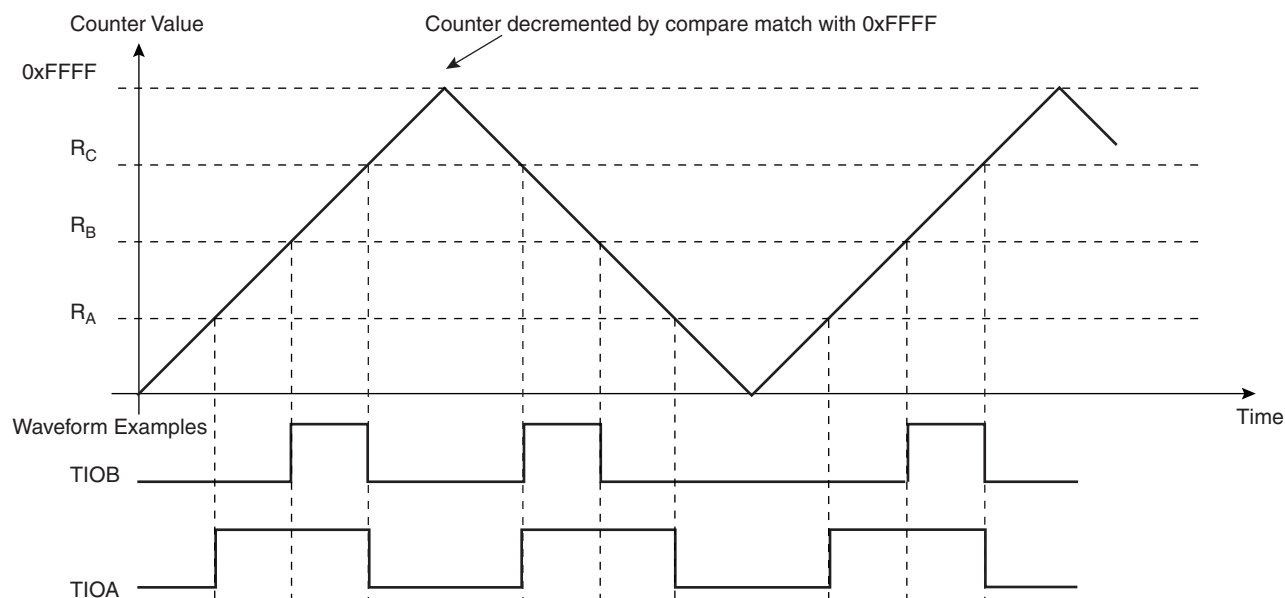
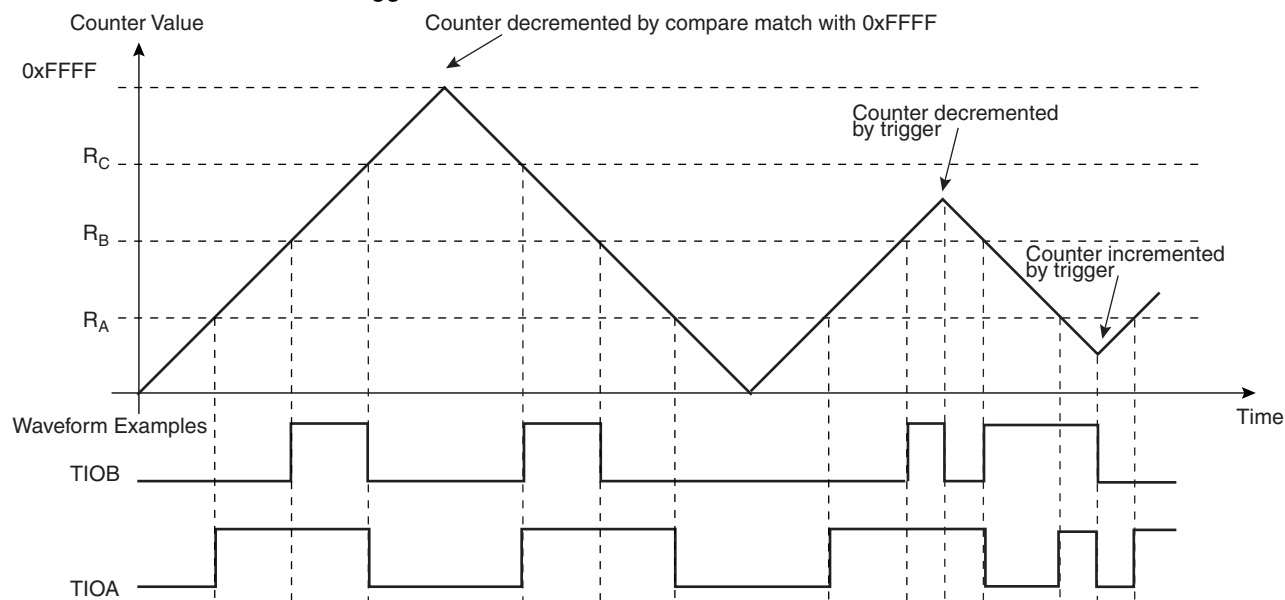

Figure 33-11. WAVSEL = 01 With Trigger



33.6.3.5 WAVSEL = 11

When WAVSEL = 11, the value of CV is incremented from 0 to R_C . Once R_C is reached, the value of CV is decremented to 0, then re-incremented to R_C and so on. See [Figure 33-12](#).

A trigger such as an external event or a software trigger can modify CV at any time. If a trigger occurs while CV is incrementing, CV then decrements. If a trigger is received while CV is decrementing, CV then increments. See [Figure 33-13](#).

R_C Compare can stop the counter clock (CPCSTOP = 1) and/or disable the counter clock (CPCDIS = 1).

Figure 33-12. WAVSEL = 11 Without Trigger

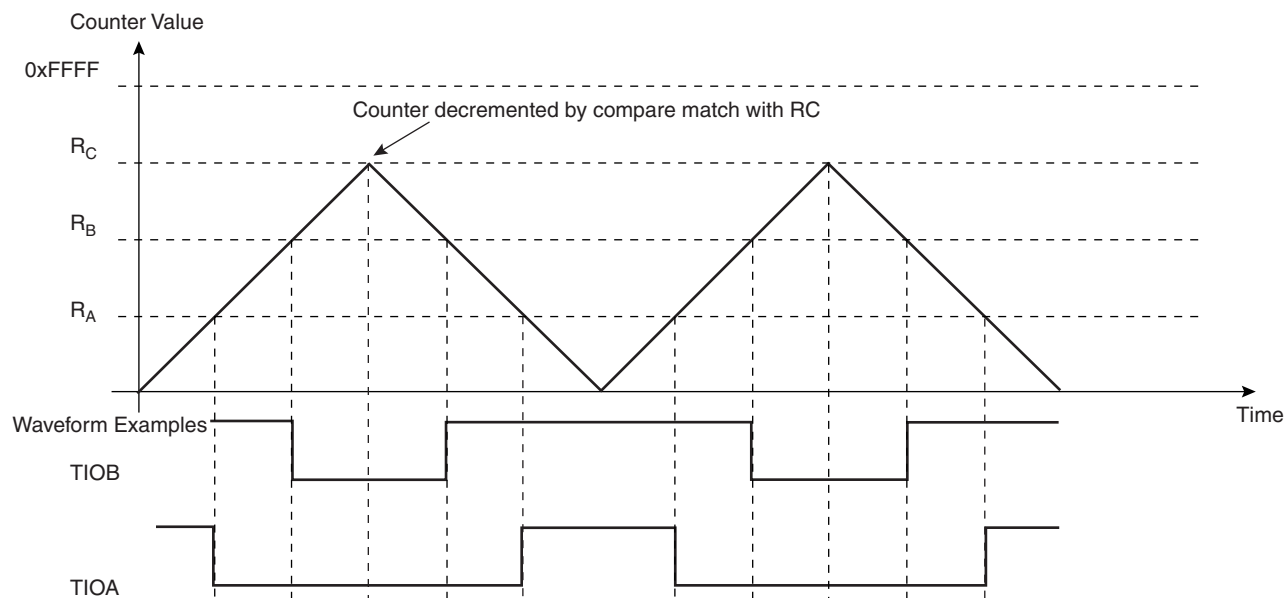
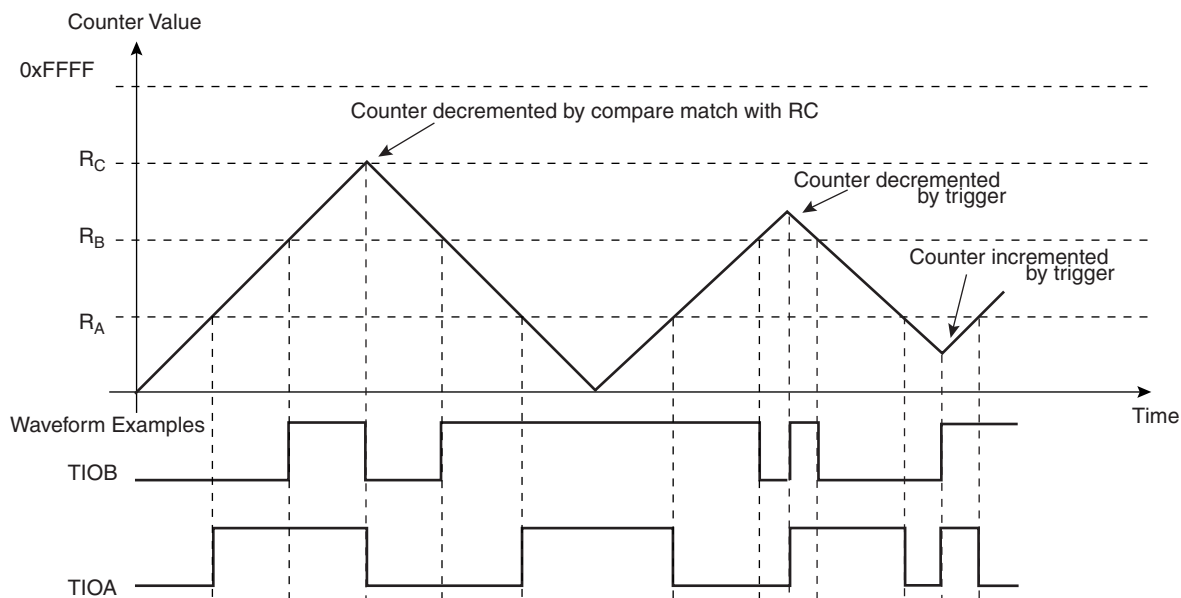

Figure 33-13. WAVSEL = 11 With Trigger



33.6.3.6 External Event/Trigger Conditions

An external event can be programmed to be detected on one of the clock sources (XC0, XC1, XC2) or TIOB. The external event selected can then be used as a trigger.

The EEVT parameter in CMR selects the external trigger. The EEVTEG parameter defines the trigger edge for each of the possible external triggers (rising, falling or both). If EEVTEG is cleared (none), no external event is defined.

If TIOB is defined as an external event signal (EEVT = 0), TIOB is no longer used as an output and the compare register B is not used to generate waveforms and subsequently no IRQs. In this case the TC channel can only generate a waveform on TIOA.

When an external event is defined, it can be used as a trigger by setting bit ENETRIG in CMR.

As in Capture Mode, the SYNC signal and the software trigger are also available as triggers. RC Compare can also be used as a trigger depending on the parameter WAVSEL.

33.6.3.7 *Output Controller*

The output controller defines the output level changes on TIOA and TIOB following an event. TIOB control is used only if TIOB is defined as output (not as an external event).

The following events control TIOA and TIOB: software trigger, external event and RC compare. RA compare controls TIOA and RB compare controls TIOB. Each of these events can be programmed to set, clear or toggle the output as defined in the corresponding parameter in CMR.

33.7 Timer Counter (TC) User Interface

Table 33-3. TC Global Memory Map

Offset	Channel/Register	Name	Access	Reset Value
0x00	TC Channel 0		See Table 33-4	
0x40	TC Channel 1		See Table 33-4	
0x80	TC Channel 2		See Table 33-4	
0xC0	TC Block Control Register	BCR	Write-only	–
0xC4	TC Block Mode Register	BMR	Read/Write	0

BCR (Block Control Register) and BMR (Block Mode Register) control the whole TC block. TC channels are controlled by the registers listed in [Table 33-4](#). The offset of each of the channel registers in [Table 33-4](#) is in relation to the offset of the corresponding channel as mentioned in [Table 33-4](#).

Table 33-4. TC Channel Memory Map

Offset	Register	Name	Access	Reset Value
0x00	Channel Control Register	CCR	Write-only	–
0x04	Channel Mode Register	CMR	Read/Write	0
0x08	Reserved			–
0x0C	Reserved			–
0x10	Counter Value	CV	Read-only	0
0x14	Register A	RA	Read/Write ⁽¹⁾	0
0x18	Register B	RB	Read/Write ⁽¹⁾	0
0x1C	Register C	RC	Read/Write	0
0x20	Status Register	SR	Read-only	0
0x24	Interrupt Enable Register	IER	Write-only	–
0x28	Interrupt Disable Register	IDR	Write-only	–
0x2C	Interrupt Mask Register	IMR	Read-only	0

Notes: 1. Read-only if WAVE = 0

33.7.1 TC Block Control Register

Register Name: BCR

Access Type: Write-only

31	30	29	28	27	26	25	24
-	-	-	-	-	-	-	-
23	22	21	20	19	18	17	16
-	-	-	-	-	-	-	-
15	14	13	12	11	10	9	8
-	-	-	-	-	-	-	-
7	6	5	4	3	2	1	0
-	-	-	-	-	-	-	SYNC

• **SYNC: Synchro Command**

0 = No effect.

1 = Asserts the SYNC signal which generates a software trigger simultaneously for each of the channels.

33.7.2 TC Block Mode Register

Register Name: BMR

Access Type: Read/Write

31	30	29	28	27	26	25	24
–	–	–	–	–	–	–	–
23	22	21	20	19	18	17	16
–	–	–	–	–	–	–	–
15	14	13	12	11	10	9	8
–	–	–	–	–	–	–	–
7	6	5	4	3	2	1	0
–	–	TC2XC2S		TC1XC1S		TC0XC0S	

- **TC0XC0S: External Clock Signal 0 Selection**

TC0XC0S		Signal Connected to XC0
0	0	TCLK0
0	1	none
1	0	TIOA1
1	1	TIOA2

- **TC1XC1S: External Clock Signal 1 Selection**

TC1XC1S		Signal Connected to XC1
0	0	TCLK1
0	1	none
1	0	TIOA0
1	1	TIOA2

- **TC2XC2S: External Clock Signal 2 Selection**

TC2XC2S		Signal Connected to XC2
0	0	TCLK2
0	1	none
1	0	TIOA0
1	1	TIOA1

33.7.3 TC Channel Control Register

Register Name: CCR

Access Type: Write-only

31	30	29	28	27	26	25	24
–	–	–	–	–	–	–	–
23	22	21	20	19	18	17	16
–	–	–	–	–	–	–	–
15	14	13	12	11	10	9	8
–	–	–	–	–	–	–	–
7	6	5	4	3	2	1	0
–	–	–	–	–	SWTRG	CLKDIS	CLKEN

- **CLKEN: Counter Clock Enable Command**

0 = No effect.

1 = Enables the clock if CLKDIS is not 1.

- **CLKDIS: Counter Clock Disable Command**

0 = No effect.

1 = Disables the clock.

- **SWTRG: Software Trigger Command**

0 = No effect.

1 = A software trigger is performed: the counter is reset and the clock is started.

33.7.4 TC Channel Mode Register: Capture Mode

Register Name: CMR

Access Type: Read/Write

31	30	29	28	27	26	25	24
–	–	–	–	–	–	–	–
23	22	21	20	19	18	17	16
–	–	–	–	LDRB		LDRA	
15	14	13	12	11	10	9	8
WAVE = 0	CPCTRG	–	–	–	ABETRG	ETRGEDG	
7	6	5	4	3	2	1	0
LDBDIS	LDBSTOP	BURST		CLKI	TCCLKS		

- **TCCLKS: Clock Selection**

TCCLKS			Clock Selected
0	0	0	TIMER_CLOCK1
0	0	1	TIMER_CLOCK2
0	1	0	TIMER_CLOCK3
0	1	1	TIMER_CLOCK4
1	0	0	TIMER_CLOCK5
1	0	1	XC0
1	1	0	XC1
1	1	1	XC2

- **CLKI: Clock Invert**

0 = Counter is incremented on rising edge of the clock.

1 = Counter is incremented on falling edge of the clock.

- **BURST: Burst Signal Selection**

BURST		
0	0	The clock is not gated by an external signal.
0	1	XC0 is ANDed with the selected clock.
1	0	XC1 is ANDed with the selected clock.
1	1	XC2 is ANDed with the selected clock.

- **LDBSTOP: Counter Clock Stopped with RB Loading**

0 = Counter clock is not stopped when RB loading occurs.

1 = Counter clock is stopped when RB loading occurs.

- **LDBDIS: Counter Clock Disable with RB Loading**

0 = Counter clock is not disabled when RB loading occurs.

1 = Counter clock is disabled when RB loading occurs.

- **ETRGEDG: External Trigger Edge Selection**

ETRGEDG		Edge
0	0	none
0	1	rising edge
1	0	falling edge
1	1	each edge

- **ABETRG: TIOA or TIOB External Trigger Selection**

0 = TIOB is used as an external trigger.

1 = TIOA is used as an external trigger.

- **CPCTRG: RC Compare Trigger Enable**

0 = RC Compare has no effect on the counter and its clock.

1 = RC Compare resets the counter and starts the counter clock.

- **WAVE**

0 = Capture Mode is enabled.

1 = Capture Mode is disabled (Waveform Mode is enabled).

- **LDRA: RA Loading Selection**

LDRA		Edge
0	0	none
0	1	rising edge of TIOA
1	0	falling edge of TIOA
1	1	each edge of TIOA

- **LDRB: RB Loading Selection**

LDRB		Edge
0	0	none
0	1	rising edge of TIOA
1	0	falling edge of TIOA
1	1	each edge of TIOA

33.7.5 TC Channel Mode Register: Waveform Mode

Register Name: CMR

Access Type: Read/Write

31	30	29	28	27	26	25	24
BSWTRG		BEEVT		BCPC		BCPB	
23	22	21	20	19	18	17	16
ASWTRG		AEEVT		ACPC		ACPA	
15	14	13	12	11	10	9	8
WAVE = 1	WAVSEL		ENETRГ	EEVT		EEVTEDG	
7	6	5	4	3	2	1	0
CPCDIS	CPCSTOP	BURST		CLKI	TCCLKS		

- **TCCLKS: Clock Selection**

TCCLKS			Clock Selected
0	0	0	TIMER_CLOCK1
0	0	1	TIMER_CLOCK2
0	1	0	TIMER_CLOCK3
0	1	1	TIMER_CLOCK4
1	0	0	TIMER_CLOCK5
1	0	1	XC0
1	1	0	XC1
1	1	1	XC2

- **CLKI: Clock Invert**

0 = Counter is incremented on rising edge of the clock.

1 = Counter is incremented on falling edge of the clock.

- **BURST: Burst Signal Selection**

BURST		
0	0	The clock is not gated by an external signal.
0	1	XC0 is ANDed with the selected clock.
1	0	XC1 is ANDed with the selected clock.
1	1	XC2 is ANDed with the selected clock.

- **CPCSTOP: Counter Clock Stopped with RC Compare**

0 = Counter clock is not stopped when counter reaches RC.

1 = Counter clock is stopped when counter reaches RC.

- **CPCDIS: Counter Clock Disable with RC Compare**

0 = Counter clock is not disabled when counter reaches RC.

1 = Counter clock is disabled when counter reaches RC.

• **EEVTEDG: External Event Edge Selection**

EEVTEDG		Edge
0	0	none
0	1	rising edge
1	0	falling edge
1	1	each edge

• **EEVT: External Event Selection**

EEVT		Signal selected as external event	TIOB Direction
0	0	TIOB	input ⁽¹⁾
0	1	XC0	output
1	0	XC1	output
1	1	XC2	output

Note: 1. If TIOB is chosen as the external event signal, it is configured as an input and no longer generates waveforms and subsequently no IRQs.

• **ENETRQ: External Event Trigger Enable**

0 = The external event has no effect on the counter and its clock. In this case, the selected external event only controls the TIOA output.

1 = The external event resets the counter and starts the counter clock.

• **WAVSEL: Waveform Selection**

WAVSEL		Effect
0	0	UP mode without automatic trigger on RC Compare
1	0	UP mode with automatic trigger on RC Compare
0	1	UPDOWN mode without automatic trigger on RC Compare
1	1	UPDOWN mode with automatic trigger on RC Compare

• **WAVE = 1**

0 = Waveform Mode is disabled (Capture Mode is enabled).

1 = Waveform Mode is enabled.

- **ACPA: RA Compare Effect on TIOA**

ACPA		Effect
0	0	none
0	1	set
1	0	clear
1	1	toggle

- **ACPC: RC Compare Effect on TIOA**

ACPC		Effect
0	0	none
0	1	set
1	0	clear
1	1	toggle

- **AEEVT: External Event Effect on TIOA**

AEEVT		Effect
0	0	none
0	1	set
1	0	clear
1	1	toggle

- **ASWTRG: Software Trigger Effect on TIOA**

ASWTRG		Effect
0	0	none
0	1	set
1	0	clear
1	1	toggle

- **BCPB: RB Compare Effect on TIOB**

BCPB		Effect
0	0	none

BCPB		Effect
0	1	set
1	0	clear
1	1	toggle

- **BCPC: RC Compare Effect on TIOB**

BCPC		Effect
0	0	none
0	1	set
1	0	clear
1	1	toggle

- **BEEVT: External Event Effect on TIOB**

BEEVT		Effect
0	0	none
0	1	set
1	0	clear
1	1	toggle

- **BSWTRG: Software Trigger Effect on TIOB**

BSWTRG		Effect
0	0	none
0	1	set
1	0	clear
1	1	toggle

33.7.6 TC Counter Value Register

Register Name: CV

Access Type: Read-only

31	30	29	28	27	26	25	24
-	-	-	-	-	-	-	-
23	22	21	20	19	18	17	16
-	-	-	-	-	-	-	-
15	14	13	12	11	10	9	8
CV							
7	6	5	4	3	2	1	0
CV							

- **CV: Counter Value**

CV contains the counter value in real time.

33.7.7 TC Register A

Register Name: RA

Access Type: Read-only if WAVE = 0, Read/Write if WAVE = 1

31	30	29	28	27	26	25	24
-	-	-	-	-	-	-	-
23	22	21	20	19	18	17	16
-	-	-	-	-	-	-	-
15	14	13	12	11	10	9	8
RA							
7	6	5	4	3	2	1	0
RA							

- **RA: Register A**

RA contains the Register A value in real time.

33.7.8 TC Register B

Register Name: RB

Access Type: Read-only if WAVE = 0, Read/Write if WAVE = 1

31	30	29	28	27	26	25	24
-	-	-	-	-	-	-	-
23	22	21	20	19	18	17	16
-	-	-	-	-	-	-	-
15	14	13	12	11	10	9	8
RB							
7	6	5	4	3	2	1	0
RB							

- **RB: Register B**

RB contains the Register B value in real time.

33.7.9 TC Register C

Register Name: RC

Access Type: Read/Write

31	30	29	28	27	26	25	24
-	-	-	-	-	-	-	-
23	22	21	20	19	18	17	16
-	-	-	-	-	-	-	-
15	14	13	12	11	10	9	8
RC							
7	6	5	4	3	2	1	0
RC							

- **RC: Register C**

RC contains the Register C value in real time.

33.7.10 TC Status Register

Register Name: SR

Access Type: Read-only

31	30	29	28	27	26	25	24
–	–	–	–	–	–	–	–
23	22	21	20	19	18	17	16
–	–	–	–	–	MTIOB	MTIOA	CLKSTA
15	14	13	12	11	10	9	8
–	–	–	–	–	–	–	–
7	6	5	4	3	2	1	0
ETRGS	LDRBS	LDRAS	CPCS	CPBS	CPAS	LOVRS	COVFS

- **COVFS: Counter Overflow Status**

0 = No counter overflow has occurred since the last read of the Status Register.

1 = A counter overflow has occurred since the last read of the Status Register.

- **LOVRS: Load Overrun Status**

0 = Load overrun has not occurred since the last read of the Status Register or WAVE = 1.

1 = RA or RB have been loaded at least twice without any read of the corresponding register since the last read of the Status Register, if WAVE = 0.

- **CPAS: RA Compare Status**

0 = RA Compare has not occurred since the last read of the Status Register or WAVE = 0.

1 = RA Compare has occurred since the last read of the Status Register, if WAVE = 1.

- **CPBS: RB Compare Status**

0 = RB Compare has not occurred since the last read of the Status Register or WAVE = 0.

1 = RB Compare has occurred since the last read of the Status Register, if WAVE = 1.

- **CPCS: RC Compare Status**

0 = RC Compare has not occurred since the last read of the Status Register.

1 = RC Compare has occurred since the last read of the Status Register.

- **LDRAS: RA Loading Status**

0 = RA Load has not occurred since the last read of the Status Register or WAVE = 1.

1 = RA Load has occurred since the last read of the Status Register, if WAVE = 0.

- **LDRBS: RB Loading Status**

0 = RB Load has not occurred since the last read of the Status Register or WAVE = 1.

1 = RB Load has occurred since the last read of the Status Register, if WAVE = 0.

- **ETRGS: External Trigger Status**

0 = External trigger has not occurred since the last read of the Status Register.

1 = External trigger has occurred since the last read of the Status Register.

- **CLKSTA: Clock Enabling Status**

0 = Clock is disabled.

1 = Clock is enabled.

- **MTIOA: TIOA Mirror**

0 = TIOA is low. If WAVE = 0, this means that TIOA pin is low. If WAVE = 1, this means that TIOA is driven low.

1 = TIOA is high. If WAVE = 0, this means that TIOA pin is high. If WAVE = 1, this means that TIOA is driven high.

- **MTIOB: TIOB Mirror**

0 = TIOB is low. If WAVE = 0, this means that TIOB pin is low. If WAVE = 1, this means that TIOB is driven low.

1 = TIOB is high. If WAVE = 0, this means that TIOB pin is high. If WAVE = 1, this means that TIOB is driven high.

33.7.11 TC Interrupt Enable Register

Register Name: IER

Access Type: Write-only

31	30	29	28	27	26	25	24
–	–	–	–	–	–	–	–
23	22	21	20	19	18	17	16
–	–	–	–	–	–	–	–
15	14	13	12	11	10	9	8
–	–	–	–	–	–	–	–
7	6	5	4	3	2	1	0
ETRGS	LDRBS	LDRAS	CPCS	CPBS	CPAS	LOVRS	COVFS

- **COVFS: Counter Overflow**

0 = No effect.

1 = Enables the Counter Overflow Interrupt.

- **LOVRS: Load Overrun**

0 = No effect.

1 = Enables the Load Overrun Interrupt.

- **CPAS: RA Compare**

0 = No effect.

1 = Enables the RA Compare Interrupt.

- **CPBS: RB Compare**

0 = No effect.

1 = Enables the RB Compare Interrupt.

- **CPCS: RC Compare**

0 = No effect.

1 = Enables the RC Compare Interrupt.

- **LDRAS: RA Loading**

0 = No effect.

1 = Enables the RA Load Interrupt.

- **LDRBS: RB Loading**

0 = No effect.

1 = Enables the RB Load Interrupt.

- **ETRGS: External Trigger**

0 = No effect.

1 = Enables the External Trigger Interrupt.

33.7.12 TC Interrupt Disable Register

Register Name: IDR

Access Type: Write-only

31	30	29	28	27	26	25	24
-	-	-	-	-	-	-	-
23	22	21	20	19	18	17	16
-	-	-	-	-	-	-	-
15	14	13	12	11	10	9	8
-	-	-	-	-	-	-	-
7	6	5	4	3	2	1	0
ETRGS	LDRBS	LDRAS	CPCS	CPBS	CPAS	LOVRS	COVFS

- **COVFS: Counter Overflow**

0 = No effect.

1 = Disables the Counter Overflow Interrupt.

- **LOVRS: Load Overrun**

0 = No effect.

1 = Disables the Load Overrun Interrupt (if WAVE = 0).

- **CPAS: RA Compare**

0 = No effect.

1 = Disables the RA Compare Interrupt (if WAVE = 1).

- **CPBS: RB Compare**

0 = No effect.

1 = Disables the RB Compare Interrupt (if WAVE = 1).

- **CPCS: RC Compare**

0 = No effect.

1 = Disables the RC Compare Interrupt.

- **LDRAS: RA Loading**

0 = No effect.

1 = Disables the RA Load Interrupt (if WAVE = 0).

- **LDRBS: RB Loading**

0 = No effect.

1 = Disables the RB Load Interrupt (if WAVE = 0).

- **ETRGS: External Trigger**

0 = No effect.

1 = Disables the External Trigger Interrupt.

33.7.13 TC Interrupt Mask Register

Register Name: IMR

Access Type: Read-only

31	30	29	28	27	26	25	24
–	–	–	–	–	–	–	–
23	22	21	20	19	18	17	16
–	–	–	–	–	–	–	–
15	14	13	12	11	10	9	8
–	–	–	–	–	–	–	–
7	6	5	4	3	2	1	0
ETRGS	LDRBS	LDRAS	CPCS	CPBS	CPAS	LOVRS	COVFS

- **COVFS: Counter Overflow**

0 = The Counter Overflow Interrupt is disabled.

1 = The Counter Overflow Interrupt is enabled.

- **LOVRS: Load Overrun**

0 = The Load Overrun Interrupt is disabled.

1 = The Load Overrun Interrupt is enabled.

- **CPAS: RA Compare**

0 = The RA Compare Interrupt is disabled.

1 = The RA Compare Interrupt is enabled.

- **CPBS: RB Compare**

0 = The RB Compare Interrupt is disabled.

1 = The RB Compare Interrupt is enabled.

- **CPCS: RC Compare**

0 = The RC Compare Interrupt is disabled.

1 = The RC Compare Interrupt is enabled.

- **LDRAS: RA Loading**

0 = The Load RA Interrupt is disabled.

1 = The Load RA Interrupt is enabled.

- **LDRBS: RB Loading**

0 = The Load RB Interrupt is disabled.

1 = The Load RB Interrupt is enabled.

- **ETRGS: External Trigger**

0 = The External Trigger Interrupt is disabled.

1 = The External Trigger Interrupt is enabled.

34. Pulse Width Modulation Controller (PWM)

Rev: 6044E

34.1 Features

- 4 Channels
- One 20-bit Counter Per Channel
- Common Clock Generator Providing Thirteen Different Clocks
 - A Modulo n Counter Providing Eleven Clocks
 - Two Independent Linear Dividers Working on Modulo n Counter Outputs
- Independent Channels
 - Independent Enable Disable Command for Each Channel
 - Independent Clock Selection for Each Channel
 - Independent Period and Duty Cycle for Each Channel
 - Double Buffering of Period or Duty Cycle for Each Channel
 - Programmable Selection of The Output Waveform Polarity for Each Channel
 - Programmable Center or Left Aligned Output Waveform for Each Channel

34.2 Description

The PWM macrocell controls several channels independently. Each channel controls one square output waveform. Characteristics of the output waveform such as period, duty-cycle and polarity are configurable through the user interface. Each channel selects and uses one of the clocks provided by the clock generator. The clock generator provides several clocks resulting from the division of the PWM macrocell master clock.

All PWM macrocell accesses are made through registers mapped on the peripheral bus.

Channels can be synchronized, to generate non overlapped waveforms. All channels integrate a double buffering system in order to prevent an unexpected output waveform while modifying the period or the duty-cycle.

34.3 Block Diagram

Figure 34-1. Pulse Width Modulation Controller Block Diagram

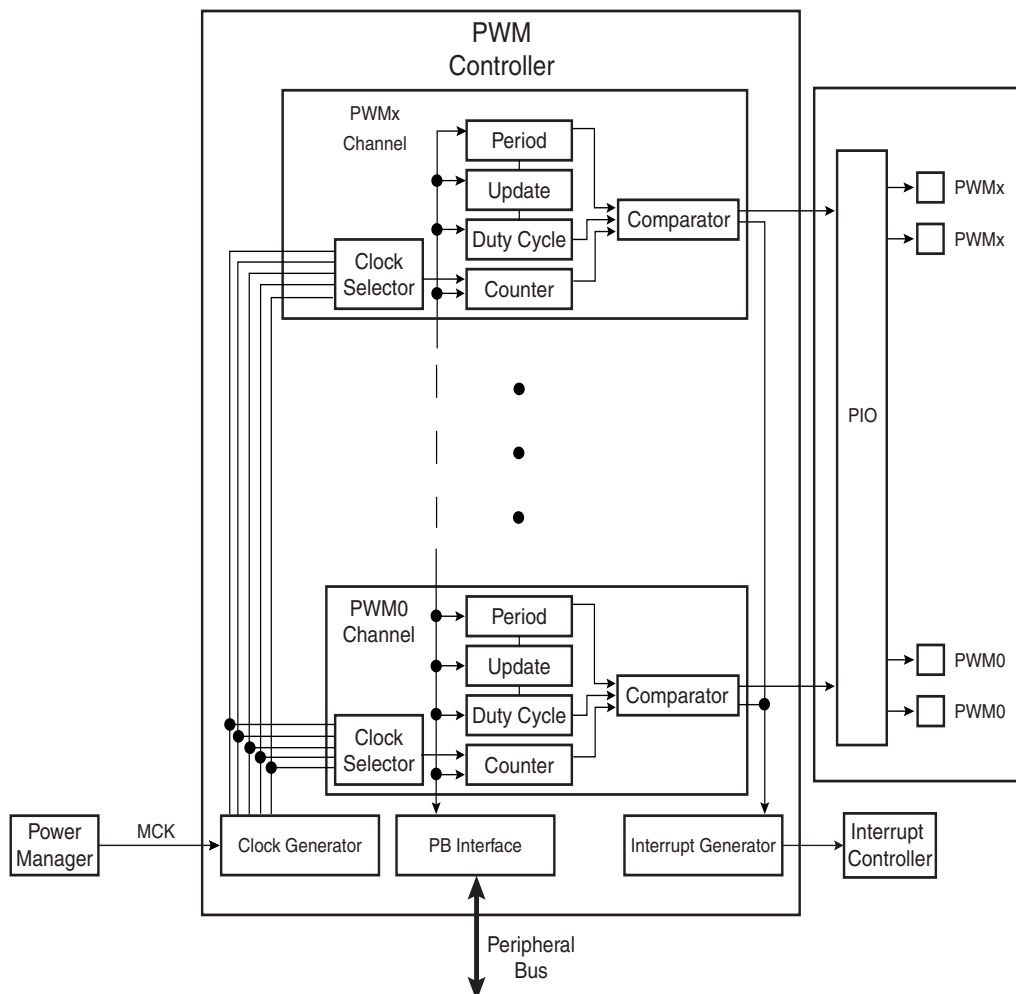

34.4 I/O Lines Description

Each channel outputs one waveform on one external I/O line.

Table 34-1. I/O Line Description

Name	Description	Type
PWMx	PWM Waveform Output for channel x	Output

34.5 Product Dependencies

34.5.1 I/O Lines

The pins used for interfacing the PWM may be multiplexed with PIO lines. The programmer must first program the PIO controller to assign the desired PWM pins to their peripheral function. If I/O lines of the PWM are not used by the application, they can be used for other purposes by the PIO controller.

Not all PWM outputs may be enabled. If an application requires only four channels, then only four PIO lines will be assigned to PWM outputs.

34.5.2 Power Management

The PWM clock is generated by the Power Manager. Before using the PWM, the programmer must ensure that the TWI clock is enabled in the Power Manager. However, if the application does not require PWM operations, the PWM clock can be stopped when not needed and be restarted later. In this case, the PWM will resume its operations where it left off.

In the PWM description, Master Clock (MCK) is the clock of the peripheral bus to which the PWM is connected.

34.5.3 Interrupt Sources

The PWM interrupt line is connected to the interrupt controller. Using the PWM interrupt requires the interrupt controller to be programmed first.

34.6 Functional Description

The PWM macrocell is primarily composed of a clock generator module and 4 channels.

- Clocked by the system clock, MCK, the clock generator module provides 13 clocks.
- Each channel can independently choose one of the clock generator outputs.
- Each channel generates an output waveform with attributes that can be defined independently for each channel through the user interface registers.

34.6.1 PWM Clock Generator

Figure 34-2. Functional View of the Clock Generator Block Diagram

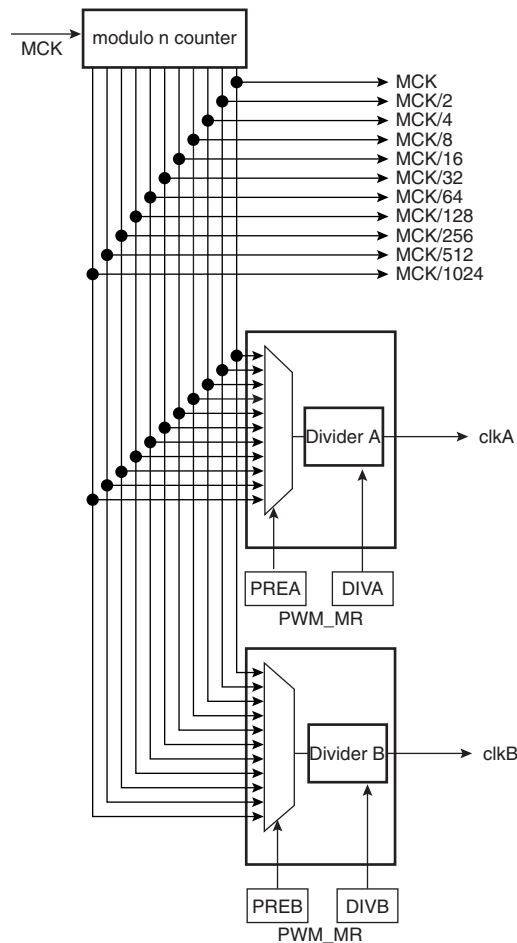

Caution: Before using the PWM macrocell, the programmer must ensure that the PWM clock in the Power Manager is enabled.

The PWM macrocell master clock, MCK, is divided in the clock generator module to provide different clocks available for all channels. Each channel can independently select one of the divided clocks.

The clock generator is divided in three blocks:

- a modulo n counter which provides 11 clocks: F_{MCK} , $F_{MCK}/2$, $F_{MCK}/4$, $F_{MCK}/8$, $F_{MCK}/16$, $F_{MCK}/32$, $F_{MCK}/64$, $F_{MCK}/128$, $F_{MCK}/256$, $F_{MCK}/512$, $F_{MCK}/1024$
- two linear dividers (1, 1/2, 1/3, ... 1/255) that provide two separate clocks: clkA and clkB

Each linear divider can independently divide one of the clocks of the modulo n counter. The selection of the clock to be divided is made according to the PREA (PREB) field of the PWM Mode register (MR). The resulting clock clkA (clkB) is the clock selected divided by DIVA (DIVB) field value in the PWM Mode register (MR).

After a reset of the PWM controller, DIVA (DIVB) and PREA (PREB) in the PWM Mode register are set to 0. This implies that after reset clkA (clkB) are turned off.

At reset, all clocks provided by the modulo n counter are turned off except clock “clk”. This situation is also true when the PWM master clock is turned off through the Power Management Controller.

34.6.2 PWM Channel

34.6.2.1 Block Diagram

Figure 34-3. Functional View of the Channel Block Diagram

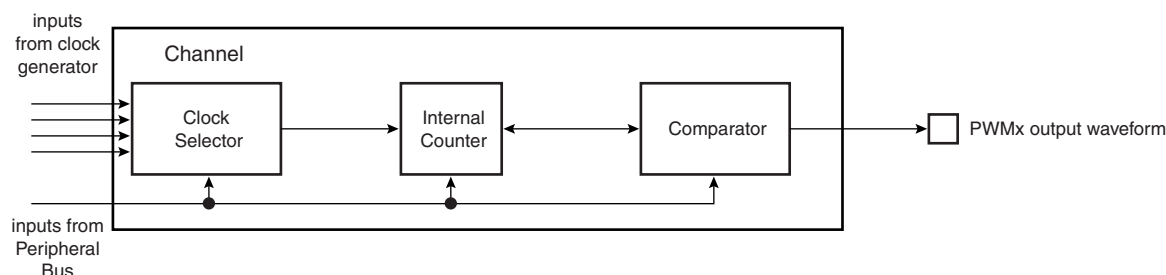

Each of the 4 channels is composed of three blocks:

- A clock selector which selects one of the clocks provided by the clock generator described in [Section 34.6.1 "PWM Clock Generator" on page 704](#).
- An internal counter clocked by the output of the clock selector. This internal counter is incremented or decremented according to the channel configuration and comparators events. The size of the internal counter is 20 bits.
- A comparator used to generate events according to the internal counter value. It also computes the PWMx output waveform according to the configuration.

34.6.2.2 Waveform Properties

The different properties of output waveforms are:

- the **internal clock selection**. The internal channel counter is clocked by one of the clocks provided by the clock generator described in the previous section. This channel parameter is defined in the CPRE field of the CMRx register. This field is reset at 0.
- the **waveform period**. This channel parameter is defined in the CPRD field of the CPRDx register.

- If the waveform is left aligned, then the output waveform period depends on the counter source clock and can be calculated:
 By using the Master Clock (MCK) divided by an X given prescaler value (with X being 1, 2, 4, 8, 16, 32, 64, 128, 256, 512, or 1024), the resulting period formula will be:

$$\frac{(X \times CPRD)}{MCK}$$

By using a Master Clock divided by one of both DIVA or DIVB divider, the formula becomes, respectively:

$$\frac{(CPRD \times DIVA)}{MCK} \text{ or } \frac{(CPRD \times DIVB)}{MCK}$$

If the waveform is center aligned then the output waveform period depends on the counter source clock and can be calculated:
 By using the Master Clock (MCK) divided by an X given prescaler value (with X being 1, 2, 4, 8, 16, 32, 64, 128, 256, 512, or 1024). The resulting period formula will be:

$$\frac{(2 \times X \times CPRD)}{MCK}$$

By using a Master Clock divided by one of both DIVA or DIVB divider, the formula becomes, respectively:

$$\frac{(2 \times CPRD \times DIVA)}{MCK} \text{ or } \frac{(2 \times CPRD \times DIVB)}{MCK}$$

- the **waveform duty cycle**. This channel parameter is defined in the CDTY field of the CDTYx register.

If the waveform is left aligned then:

$$\text{duty cycle} = \frac{(\text{period} - 1 / \text{fchannel_x_clock} \times \text{CDTY})}{\text{period}}$$

If the waveform is center aligned, then:

$$\text{duty cycle} = \frac{((\text{period}/2) - 1 / \text{fchannel_x_clock} \times \text{CDTY})}{(\text{period}/2)}$$

- the **waveform polarity**. At the beginning of the period, the signal can be at high or low level. This property is defined in the CPOL field of the CMRx register. By default the signal starts by a low level.
- the **waveform alignment**. The output waveform can be left or center aligned. Center aligned waveforms can be used to generate non overlapped waveforms. This property is defined in the CALG field of the CMRx register. The default mode is left aligned.

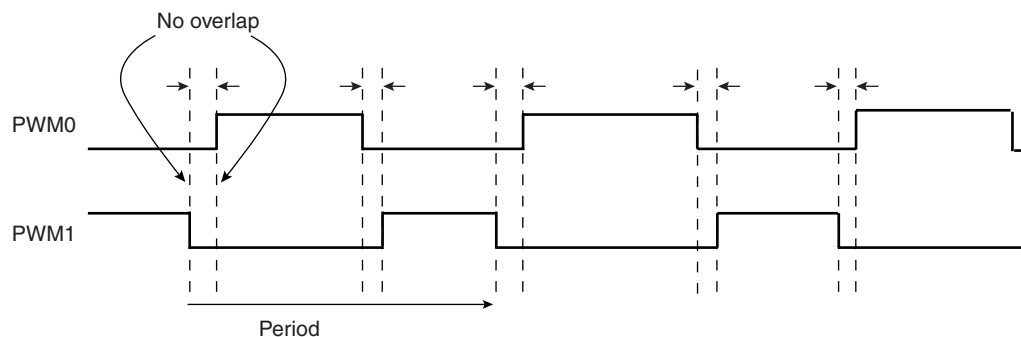
Figure 34-4. Non Overlapped Center Aligned Waveforms

Note: 1. See [Figure 34-5 on page 708](#) for a detailed description of center aligned waveforms.

When center aligned, the internal channel counter increases up to CPRD and decreases down to 0. This ends the period.

When left aligned, the internal channel counter increases up to CPRD and is reset. This ends the period.

Thus, for the same CPRD value, the period for a center aligned channel is twice the period for a left aligned channel.

Waveforms are fixed at 0 when:

- CDTY = CPRD and CPOL = 0
- CDTY = 0 and CPOL = 1

Waveforms are fixed at 1 (once the channel is enabled) when:

- CDTY = 0 and CPOL = 0
- CDTY = CPRD and CPOL = 1

The waveform polarity must be set before enabling the channel. This immediately affects the channel output level. Changes on channel polarity are not taken into account while the channel is enabled.

Figure 34-5. Waveform Properties

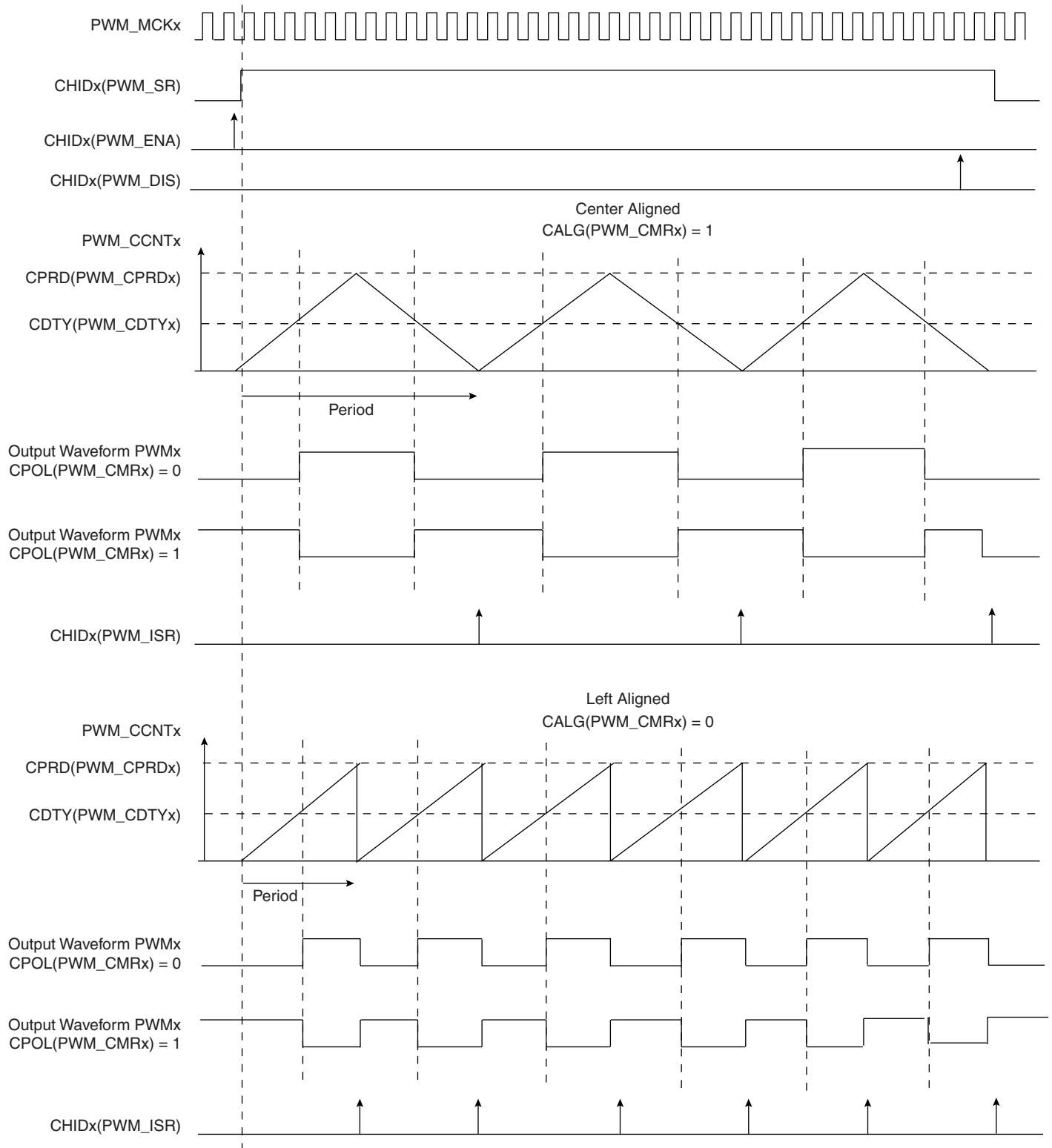

34.6.3 PWM Controller Operations

34.6.3.1 Initialization

Before enabling the output channel, this channel must have been configured by the software application:

- Configuration of the clock generator if DIVA and DIVB are required
- Selection of the clock for each channel (CPRE field in the CMRx register)
- Configuration of the waveform alignment for each channel (CALG field in the CMRx register)
- Configuration of the period for each channel (CPRD in the CPRDx register). Writing in CPRDx Register is possible while the channel is disabled. After validation of the channel, the user must use CUPDx Register to update CPRDx as explained below.
- Configuration of the duty cycle for each channel (CDTY in the CDTYx register). Writing in CDTYx Register is possible while the channel is disabled. After validation of the channel, the user must use CUPDx Register to update CDTYx as explained below.
- Configuration of the output waveform polarity for each channel (CPOL in the CMRx register)
- Enable Interrupts (Writing CHIDx in the IER register)
- Enable the PWM channel (Writing CHIDx in the ENA register)

It is possible to synchronize different channels by enabling them at the same time by means of writing simultaneously several CHIDx bits in the ENA register.

In such a situation, all channels may have the same clock selector configuration and the same period specified.

34.6.3.2 Source Clock Selection Criteria

The large number of source clocks can make selection difficult. The relationship between the value in the Period Register (CPRDx) and the Duty Cycle Register (CDTYx) can help the user in choosing. The event number written in the Period Register gives the PWM accuracy. The Duty Cycle quantum cannot be lower than $1/CPRDx$ value. The higher the value of CPRDx, the greater the PWM accuracy.

For example, if the user sets 15 (in decimal) in CPRDx, the user is able to set a value between 1 up to 14 in CDTYx Register. The resulting duty cycle quantum cannot be lower than 1/15 of the PWM period.

34.6.3.3 Changing the Duty Cycle or the Period

It is possible to modulate the output waveform duty cycle or period.

To prevent unexpected output waveform, the user must use the update register (PWM_CUPDx) to change waveform parameters while the channel is still enabled. The user can write a new period value or duty cycle value in the update register (CUPDx). This register holds the new value until the end of the current cycle and updates the value for the next cycle. Depending on the CPD field in the CMRx register, CUPDx either updates CPRDx or CDTYx. Note that even if the update register is used, the period must not be smaller than the duty cycle.

Figure 34-6. Synchronized Period or Duty Cycle Update

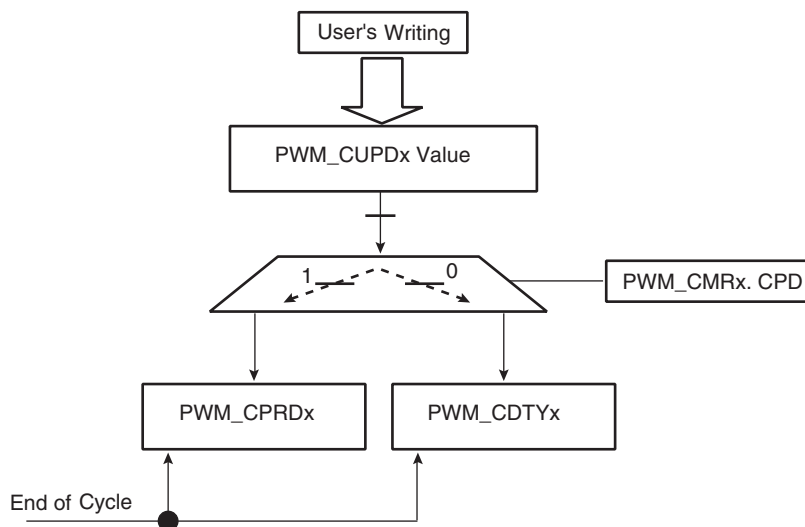

To prevent overwriting the CUPDx by software, the user can use status events in order to synchronize his software. Two methods are possible. In both, the user must enable the dedicated interrupt in IER at PWM Controller level.

The first method (polling method) consists of reading the relevant status bit in ISR Register according to the enabled channel(s). See [Figure 34-7](#).

The second method uses an Interrupt Service Routine associated with the PWM channel.

Note: Reading the ISR register automatically clears CHIDx flags.

Figure 34-7. Polling Method

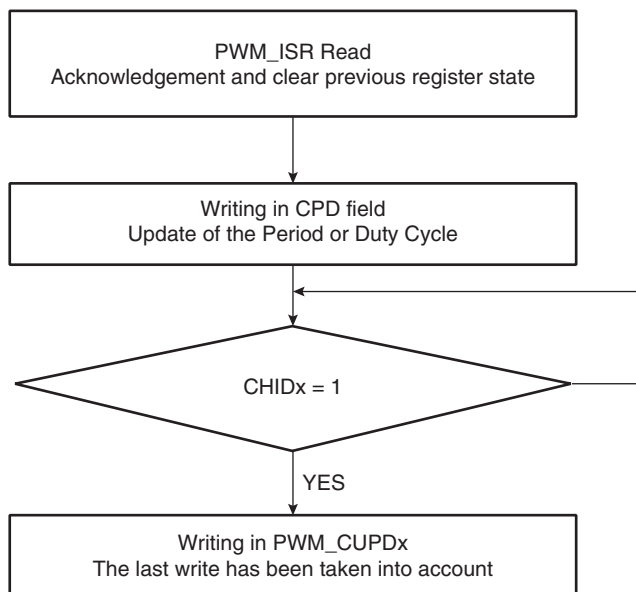

Note: Polarity and alignment can be modified only when the channel is disabled.

34.6.3.4 *Interrupts*

Depending on the interrupt mask in the IMR register, an interrupt is generated at the end of the corresponding channel period. The interrupt remains active until a read operation in the ISR register occurs.

A channel interrupt is enabled by setting the corresponding bit in the IER register. A channel interrupt is disabled by setting the corresponding bit in the IDR register.

34.7 Pulse Width Modulation (PWM) Controller User Interface

34.7.1 Register Mapping

Table 34-2. PWM Controller Registers

Offset	Register	Name	Access	Peripheral Reset Value
0x00	PWM Mode Register	MR	Read/Write	0
0x04	PWM Enable Register	ENA	Write-only	-
0x08	PWM Disable Register	DIS	Write-only	-
0x0C	PWM Status Register	SR	Read-only	0
0x10	PWM Interrupt Enable Register	IER	Write-only	-
0x14	PWM Interrupt Disable Register	IDR	Write-only	-
0x18	PWM Interrupt Mask Register	IMR	Read-only	0
0x1C	PWM Interrupt Status Register	ISR	Read-only	0
0x4C - 0xF8	Reserved	-	-	-
0x4C - 0xFC	Reserved	-	-	-
0x100 - 0x1FC	Reserved			
0x200	Channel 0 Mode Register	CMR0	Read/Write	0x0
0x204	Channel 0 Duty Cycle Register	CDTY0	Read/Write	0x0
0x208	Channel 0 Period Register	CPRD0	Read/Write	0x0
0x20C	Channel 0 Counter Register	CCNT0	Read-only	0x0
0x210	Channel 0 Update Register	CUPD0	Write-only	-
...	Reserved			
0x220	Channel 1 Mode Register	CMR1	Read/Write	0x0
0x224	Channel 1 Duty Cycle Register	CDTY1	Read/Write	0x0
0x228	Channel 1 Period Register	CPRD1	Read/Write	0x0
0x22C	Channel 1 Counter Register	CCNT1	Read-only	0x0
0x230	Channel 1 Update Register	CUPD1	Write-only	-
...

34.7.2 PWM Mode Register

Register Name: MR
Access Type: Read/Write

31	30	29	28	27	26	25	24
–	–	–	–	PREB			
23	22	21	20	19	18	17	16
DIVB							
15	14	13	12	11	10	9	8
–	–	–	–	PREA			
7	6	5	4	3	2	1	0
DIVA							

• **DIVA, DIVB: CLKA, CLKB Divide Factor**

DIVA, DIVB	CLKA, CLKB
0	CLKA, CLKB clock is turned off
1	CLKA, CLKB clock is clock selected by PREA, PREB
2-255	CLKA, CLKB clock is clock selected by PREA, PREB divided by DIVA, DIVB factor.

• **PREA, PREB**

PREA, PREB				Divider Input Clock
0	0	0	0	MCK.
0	0	0	1	MCK/2
0	0	1	0	MCK/4
0	0	1	1	MCK/8
0	1	0	0	MCK/16
0	1	0	1	MCK/32
0	1	1	0	MCK/64
0	1	1	1	MCK/128
1	0	0	0	MCK/256
1	0	0	1	MCK/512
1	0	1	0	MCK/1024
Other				Reserved

34.7.3 PWM Enable Register

Register Name: ENA

Access Type: Write-only

31	30	29	28	27	26	25	24
-	-	-	-	-	-	-	-
23	22	21	20	19	18	17	16
-	-	-	-	-	-	-	-
15	14	13	12	11	10	9	8
-	-	-	-	-	-	-	-
7	6	5	4	3	2	1	0
-	-	-	-	CHID3	CHID2	CHID1	CHID0

• CHIDx: Channel ID

0 = No effect.

1 = Enable PWM output for channel x.

34.7.4 PWM Disable Register

Register Name: DIS

Access Type: Write-only

31	30	29	28	27	26	25	24
–	–	–	–	–	–	–	–
23	22	21	20	19	18	17	16
–	–	–	–	–	–	–	–
15	14	13	12	11	10	9	8
–	–	–	–	–	–	–	–
7	6	5	4	3	2	1	0
–	–	–	–	CHID3	CHID2	CHID1	CHID0

- **CHIDx: Channel ID**

0 = No effect.

1 = Disable PWM output for channel x.

34.7.5 PWM Status Register

Register Name: SR

Access Type: Read-only

31	30	29	28	27	26	25	24
-	-	-	-	-	-	-	-
23	22	21	20	19	18	17	16
-	-	-	-	-	-	-	-
15	14	13	12	11	10	9	8
-	-	-	-	-	-	-	-
7	6	5	4	3	2	1	0
-	-	-	-	CHID3	CHID2	CHID1	CHID0

• CHIDx: Channel ID

0 = PWM output for channel x is disabled.

1 = PWM output for channel x is enabled.

34.7.6 PWM Interrupt Enable Register

Register Name: IER

Access Type: Write-only

31	30	29	28	27	26	25	24
-	-	-	-	-	-	-	-
23	22	21	20	19	18	17	16
-	-	-	-	-	-	-	-
15	14	13	12	11	10	9	8
-	-	-	-	-	-	-	-
7	6	5	4	3	2	1	0
-	-	-	-	CHID3	CHID2	CHID1	CHID0

• CHIDx: Channel ID.

0 = No effect.

1 = Enable interrupt for PWM channel x.

34.7.7 PWM Interrupt Disable Register

Register Name: IDR

Access Type: Write-only

31	30	29	28	27	26	25	24
–	–	–	–	–	–	–	–
23	22	21	20	19	18	17	16
–	–	–	–	–	–	–	–
15	14	13	12	11	10	9	8
–	–	–	–	–	–	–	–
7	6	5	4	3	2	1	0
–	–	–	–	CHID3	CHID2	CHID1	CHID0

• **CHIDx: Channel ID.**

0 = No effect.

1 = Disable interrupt for PWM channel x.

34.7.8 PWM Interrupt Mask Register

Register Name: IMR

Access Type: Read-only

31	30	29	28	27	26	25	24
–	–	–	–	–	–	–	–
23	22	21	20	19	18	17	16
–	–	–	–	–	–	–	–
15	14	13	12	11	10	9	8
–	–	–	–	–	–	–	–
7	6	5	4	3	2	1	0
–	–	–	–	CHID3	CHID2	CHID1	CHID0

- **CHIDx: Channel ID.**

0 = Interrupt for PWM channel x is disabled.

1 = Interrupt for PWM channel x is enabled.

34.7.9 PWM Interrupt Status Register

Register Name: ISR

Access Type: Read-only

31	30	29	28	27	26	25	24
–	–	–	–	–	–	–	–
23	22	21	20	19	18	17	16
–	–	–	–	–	–	–	–
15	14	13	12	11	10	9	8
–	–	–	–	–	–	–	–
7	6	5	4	3	2	1	0
–	–	–	–	CHID3	CHID2	CHID1	CHID0

• **CHIDx: Channel ID**

0 = No new channel period since the last read of the ISR register.

1 = At least one new channel period since the last read of the ISR register.

Note: Reading ISR automatically clears CHIDx flags.

34.7.10 PWM Channel Mode Register

Register Name: CMRx

Access Type: Read/Write

31	30	29	28	27	26	25	24
–	–	–	–	–	–	–	–
23	22	21	20	19	18	17	16
–	–	–	–	–	–	–	–
15	14	13	12	11	10	9	8
–	–	–	–	–	CPD	CPOL	CALG
7	6	5	4	3	2	1	0
–	–	–	–	CPRE			

- **CPRE: Channel Pre-scaler**

CPRE				Channel Pre-scaler
0	0	0	0	MCK
0	0	0	1	MCK/2
0	0	1	0	MCK/4
0	0	1	1	MCK/8
0	1	0	0	MCK/16
0	1	0	1	MCK/32
0	1	1	0	MCK/64
0	1	1	1	MCK/128
1	0	0	0	MCK/256
1	0	0	1	MCK/512
1	0	1	0	MCK/1024
1	0	1	1	CLKA
1	1	0	0	CLKB
Other				Reserved

- **CALG: Channel Alignment**

0 = The period is left aligned.

1 = The period is center aligned.

- **CPOL: Channel Polarity**

0 = The output waveform starts at a low level.

1 = The output waveform starts at a high level.

- **CPD: Channel Update Period**

0 = Writing to the CUPDx will modify the duty cycle at the next period start event.

1 = Writing to the CUPDx will modify the period at the next period start event.

34.7.11 PWM Channel Duty Cycle Register

Register Name: CDTYx

Access Type: Read/Write

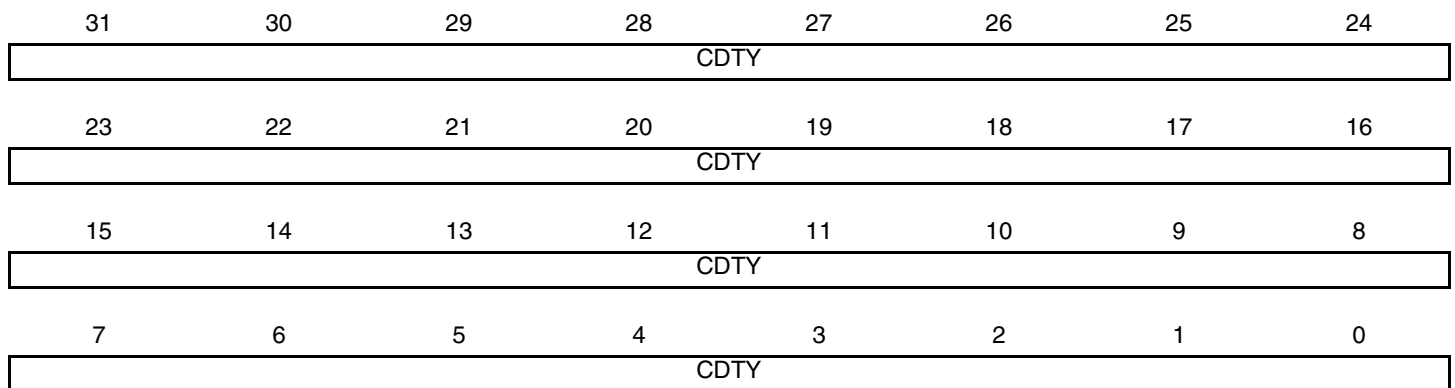

Only the first 20 bits (internal channel counter size) are significant.

- **CDTY: Channel Duty Cycle**

Defines the waveform duty cycle. This value must be defined between 0 and CPRD (CPRx).

34.7.12 PWM Channel Period Register

Register Name: CPRDx

Access Type: Read/Write

31	30	29	28	27	26	25	24
CPRD							
23	22	21	20	19	18	17	16
CPRD							
15	14	13	12	11	10	9	8
CPRD							
7	6	5	4	3	2	1	0
CPRD							

Only the first 20 bits (internal channel counter size) are significant.

- **CPRD: Channel Period**

If the waveform is left-aligned, then the output waveform period depends on the counter source clock and can be calculated:

- By using the Master Clock (MCK) divided by an X given prescaler value (with X being 1, 2, 4, 8, 16, 32, 64, 128, 256, 512, or 1024). The resulting period formula will be:

$$\frac{(X \times CPRD)}{MCK}$$

- By using a Master Clock divided by one of both DIVA or DIVB divider, the formula becomes, respectively:

$$\frac{(CPRD \times DIVA)}{MCK} \text{ or } \frac{(CPRD \times DIVB)}{MCK}$$

If the waveform is center-aligned, then the output waveform period depends on the counter source clock and can be calculated:

- By using the Master Clock (MCK) divided by an X given prescaler value (with X being 1, 2, 4, 8, 16, 32, 64, 128, 256, 512, or 1024). The resulting period formula will be:

$$\frac{(2 \times X \times CPRD)}{MCK}$$

- By using a Master Clock divided by one of both DIVA or DIVB divider, the formula becomes, respectively:

$$\frac{(2 \times CPRD \times DIVA)}{MCK} \text{ or } \frac{(2 \times CPRD \times DIVB)}{MCK}$$

34.7.13 PWM Channel Counter Register

Register Name: CCNTx

Access Type: Read-only

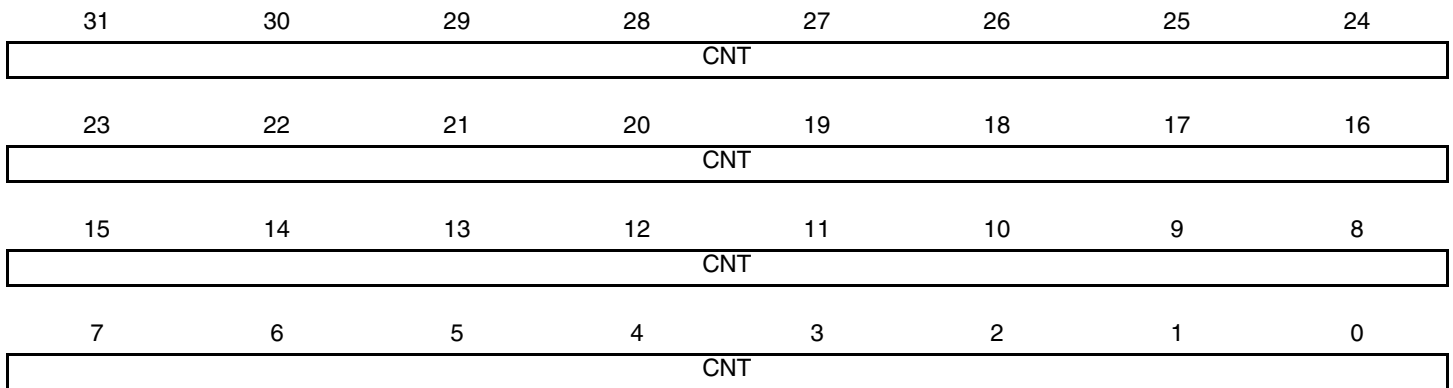

• **CNT: Channel Counter Register**

Internal counter value. This register is reset when:

- the channel is enabled (writing CHIDx in the ENA register).
- the counter reaches CPRD value defined in the CPRDx register if the waveform is left aligned.

34.7.14 PWM Channel Update Register

Register Name: CUPDx
Access Type: Write-only

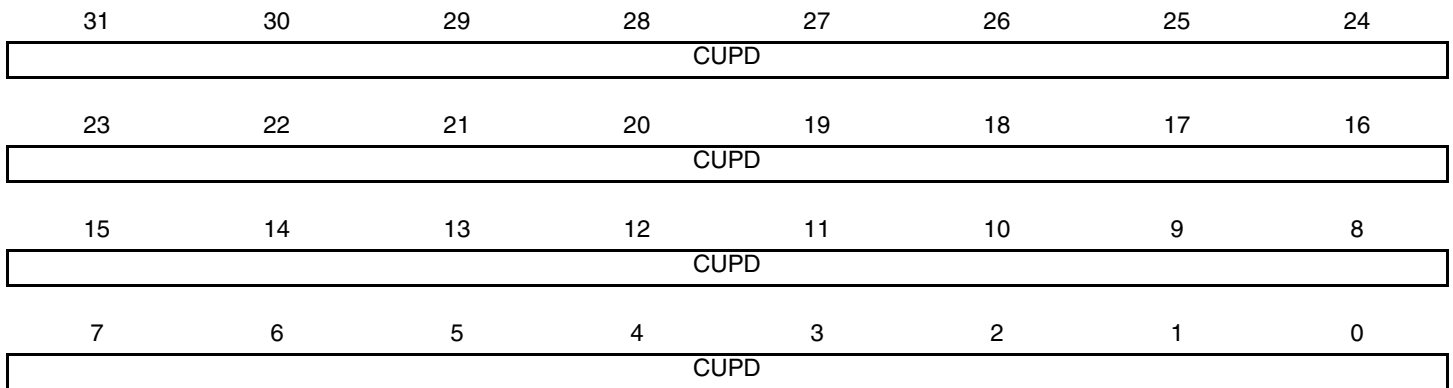

This register acts as a double buffer for the period or the duty cycle. This prevents an unexpected waveform when modifying the waveform period or duty-cycle.

Only the first 20 bits (internal channel counter size) are significant.

CPD (CMRx Register)	
0	The duty-cycle (CDTC in the CDRx register) is updated with the CUPD value at the beginning of the next period.
1	The period (CPRD in the CPRx register) is updated with the CUPD value at the beginning of the next period.

35. Image Sensor Interface (ISI)

Rev: 0.0.5.0

35.1 Features

- ITU-R BT. 601/656 8-bit Mode External Interface Support
- Supports up to 12-bit Grayscale CMOS Sensors
- Support for ITU-R BT.656-4 SAV and EAV Synchronization
- Vertical and Horizontal Resolutions up to 2048 x 2048
- Preview Path up to 640*480
- 128 Bytes FIFO on Codec Path
- 128 Bytes FIFO on Preview Path
- Support for Packed Data Formatting for YCbCr 4:2:2 Formats
- Preview Scaler to Generate Smaller Size image
- Programmable Frame Capture Rate
- VGA, QVGA, CIF, QCIF supported for LCD Preview
- Custom Formats with Horizontal and Vertical Preview Size as Multiples of 16 Also Supported for LCD Preview

35.2 Overview

The Image Sensor Interface (ISI) connects a CMOS-type image sensor to the processor and provides image capture in various formats. It does data conversion, if necessary, before the storage in memory through DMA.

The ISI supports color CMOS image sensor and grayscale image sensors with a reduced set of functionalities.

In grayscale mode, the data stream is stored in memory without any processing and so is not compatible with the LCD controller.

Internal FIFOs on the preview and codec paths are used to store the incoming data. The RGB output on the preview path is compatible with the LCD controller. This module outputs the data in RGB format (LCD compatible) and has scaling capabilities to make it compliant to the LCD display resolution (See [Table 35-3 on page 730](#)).

Several input formats such as preprocessed RGB or YCbCr are supported through the data bus interface.

It supports two modes of synchronization:

1. The hardware with VSYNC and HSYNC signals
2. The International Telecommunication Union Recommendation *ITU-R BT.656-4* Start-of-Active-Video (SAV) and End-of-Active-Video (EAV) synchronization sequence.

Using EAV/SAV for synchronization reduces the pin count (VSYNC, HSYNC not used). The polarity of the synchronization pulse is programmable to comply with the sensor signals.

Table 35-1. I/O Description

Signal	Dir	Description
VSYNC	IN	Vertical Synchronization
HSYNC	IN	Horizontal Synchronization

Table 35-1. I/O Description

DATA[11..0]	IN	Sensor Pixel Data
MCK	OUT	Master Clock Provided to the Image Sensor
PCK	IN	Pixel Clock Provided by the Image Sensor

Figure 35-1. ISI Connection Example

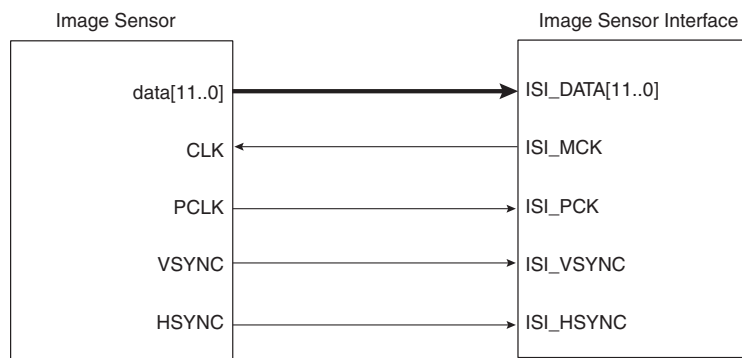

35.3 Block Diagram

Figure 35-2. Image Sensor Interface Block Diagram

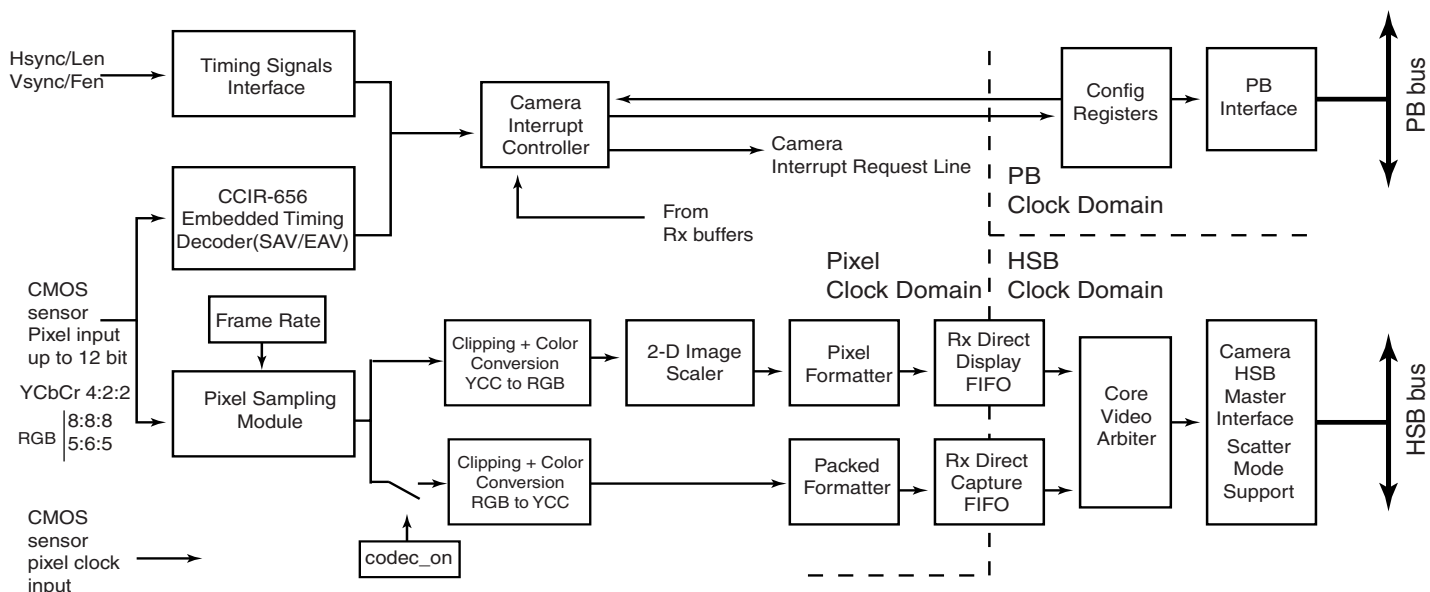

35.4 Functional Description

The Image Sensor Interface (ISI) supports direct connection to the International Telecommunication Union Recommendation ITU-R BT. 601/656 8-bit mode compliant sensors and up to 12-bit grayscale sensors. It receives the image data stream from the image sensor on the 12-bit data bus.

This module receives up to 12 bits for data, the horizontal and vertical synchronizations and the pixel clock. The reduced pin count alternative for synchronization is supported for sensors that embed SAV (start of active video) and EAV (end of active video) delimiters in the data stream.

The Image Sensor Interface interrupt line is generally connected to the Interrupt Controller and can trigger an interrupt at the beginning of each frame and at the end of a DMA frame transfer. If the SAV/EAV synchronization is used, an interrupt can be triggered on each delimiter event.

For 8-bit color sensors, the data stream received can be in several possible formats: YCbCr 4:2:2, RGB 8:8:8, RGB 5:6:5 and may be processed before the storage in memory. The data stream may be sent on both preview path and codec path if the bit CODEC_ON in the CR1 is one. To optimize the bandwidth, the codec path should be enabled only when a capture is required.

In grayscale mode, the input data stream is stored in memory without any processing. The 12-bit data, which represent the grayscale level for the pixel, is stored in memory one or two pixels per word, depending on the GS_MODE bit in the CR2 register. The codec datapath is not available when grayscale image is selected.

A frame rate counter allows users to capture all frames or 1 out of every 2 to 8 frames.

35.4.1 Data Timing

The two data timings using horizontal and vertical synchronization and EAV/SAV sequence synchronization are shown in [Figure 35-3](#) and [Figure 35-4](#).

In the VSYNC/HSYNC synchronization, the valid data is captured with the active edge of the pixel clock (PCK), after SFD lines of vertical blanking and SLD pixel clock periods delay programmed in the control register.

The ITU-RBT.656-4 defines the functional timing for an 8-bit wide interface.

There are two timing reference signals, one at the beginning of each video data block SAV (0xFF000080) and one at the end of each video data block EAV(0xFF00009D). Only data sent between EAV and SAV is captured. Horizontal blanking and vertical blanking are ignored. Use of the SAV and EAV synchronization eliminates the VSYNC and HSYNC signals from the interface, thereby reducing the pin count. In order to retrieve both frame and line synchronization properly, at least one line of vertical blanking is mandatory.

Figure 35-3. HSYNC and VSYNC Synchronization

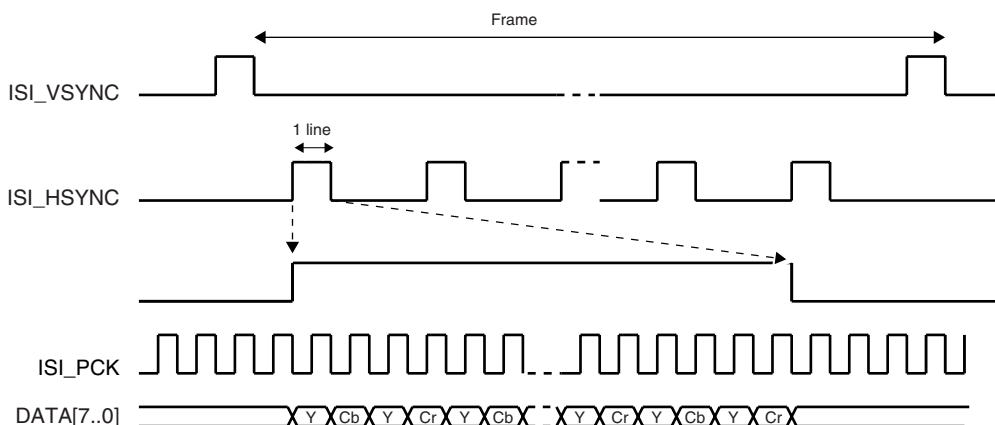
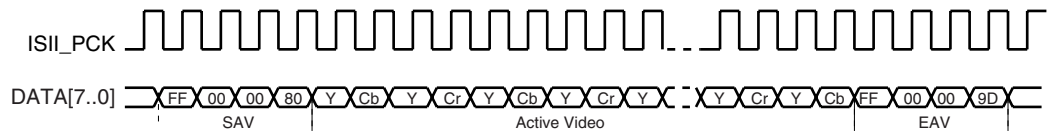

Figure 35-4. SAV and EAV Sequence Synchronization



35.4.2 Data Ordering

The RGB color space format is required for viewing images on a display screen preview, and the YCbCr color space format is required for encoding.

All the sensors do not output the YCbCr or RGB components in the same order. The ISI allows the user to program the same component order as the sensor, reducing software treatments to restore the right format.

Table 35-2. Data Ordering in YCbCr Mode

Mode	Byte 0	Byte 1	Byte 2	Byte 3
Default	Cb(i)	Y(i)	Cr(i)	Y(i+1)
Mode1	Cr(i)	Y(i)	Cb(i)	Y(i+1)
Mode2	Y(i)	Cb(i)	Y(i+1)	Cr(i)
Mode3	Y(i)	Cr(i)	Y(i+1)	Cb(i)

Table 35-3. RGB Format in Default Mode, RGB_CFG = 00, No Swap

Mode	Byte	D7	D6	D5	D4	D3	D2	D1	D0
RGB 8:8:8	Byte 0	R7(i)	R6(i)	R5(i)	R4(i)	R3(i)	R2(i)	R1(i)	R0(i)
	Byte 1	G7(i)	G6(i)	G5(i)	G4(i)	G3(i)	G2(i)	G1(i)	G0(i)
	Byte 2	B7(i)	B6(i)	B5(i)	B4(i)	B3(i)	B2(i)	B1(i)	B0(i)
	Byte 3	R7(i+1)	R6(i+1)	R5(i+1)	R4(i+1)	R3(i+1)	R2(i+1)	R1(i+1)	R0(i+1)
RGB 5:6:5	Byte 0	R4(i)	R3(i)	R2(i)	R1(i)	R0(i)	G5(i)	G4(i)	G3(i)
	Byte 1	G2(i)	G1(i)	G0(i)	B4(i)	B3(i)	B2(i)	B1(i)	B0(i)
	Byte 2	R4(i+1)	R3(i+1)	R2(i+1)	R1(i+1)	R0(i+1)	G5(i+1)	G4(i+1)	G3(i+1)
	Byte 3	G2(i+1)	G1(i+1)	G0(i+1)	B4(i+1)	B3(i+1)	B2(i+1)	B1(i+1)	B0(i+1)

Table 35-4. RGB Format, RGB_CFG = 10 (Mode 2), No Swap

Mode	Byte	D7	D6	D5	D4	D3	D2	D1	D0
RGB 5:6:5	Byte 0	G2(i)	G1(i)	G0(i)	R4(i)	R3(i)	R2(i)	R1(i)	R0(i)
	Byte 1	B4(i)	B3(i)	B2(i)	B1(i)	B0(i)	G5(i)	G4(i)	G3(i)
	Byte 2	G2(i+1)	G1(i+1)	G0(i+1)	R4(i+1)	R3(i+1)	R2(i+1)	R1(i+1)	R0(i+1)
	Byte 3	B4(i+1)	B3(i+1)	B2(i+1)	B1(i+1)	B0(i+1)	G5(i+1)	G4(i+1)	G3(i+1)

Table 35-5. RGB Format in Default Mode, RGB_CFG = 00, Swap Activated

Mode	Byte	D7	D6	D5	D4	D3	D2	D1	D0
RGB 8:8:8	Byte 0	R0(i)	R1(i)	R2(i)	R3(i)	R4(i)	R5(i)	R6(i)	R7(i)
	Byte 1	G0(i)	G1(i)	G2(i)	G3(i)	G4(i)	G5(i)	G6(i)	G7(i)
	Byte 2	B0(i)	B1(i)	B2(i)	B3(i)	B4(i)	B5(i)	B6(i)	B7(i)
	Byte 3	R0(i+1)	R1(i+1)	R2(i+1)	R3(i+1)	R4(i+1)	R5(i+1)	R6(i+1)	R7(i+1)
RGB 5:6:5	Byte 0	G3(i)	G4(i)	G5(i)	R0(i)	R1(i)	R2(i)	R3(i)	R4(i)
	Byte 1	B0(i)	B1(i)	B2(i)	B3(i)	B4(i)	G0(i)	G1(i)	G2(i)
	Byte 2	G3(i+1)	G4(i+1)	G5(i+1)	R0(i+1)	R1(i+1)	R2(i+1)	R3(i+1)	R4(i+1)
	Byte 3	B0(i+1)	B1(i+1)	B2(i+1)	B3(i+1)	B4(i+1)	G0(i+1)	G1(i+1)	G2(i+1)

The RGB 5:6:5 input format is processed to be displayed as RGB 5:5:5 format, compliant with the 16-bit mode of the LCD controller.

35.4.3 Clocks

The sensor master clock (MCK) can be generated either by the power manager through a programmable clock output or by an external oscillator connected to the sensor.

None of the sensors embeds a power management controller, so providing the clock by the power manager is a simple and efficient way to control power consumption of the system.

Care must be taken when programming the system clock. The ISI has two clock domains, the system bus clock and the pixel clock provided by sensor. The two clock domains are not synchronized, but the system clock must be faster than pixel clock.

35.4.4 Preview Path

35.4.4.1 Scaling, Decimation (Subsampling)

This module resizes captured 8-bit color sensor images to fit the LCD display format. The resize module performs only downscaling. The same ratio is applied for both horizontal and vertical resize, then a fractional decimation algorithm is applied.

The decimation factor is a multiple of 1/16 and values 0 to 15 are forbidden.

Table 35-6. Decimation Factor

Dec value	0->15	16	17	18	19	...	124	125	126	127
Dec Factor	X	1	1.063	1.125	1.188	...	7.750	7.813	7.875	7.938

Table 35-7. Decimation and Scaler Offset Values

INPUT		352*288	640*480	800*600	1280*1024	1600*1200	2048*1536
OUTPUT							
VGA 640*480	F	NA	16	20	32	40	51

Table 35-7. Decimation and Scaler Offset Values

QVGA 320*240	F	16	32	40	64	80	102
CIF 352*288	F	16	26	33	56	66	85
QCIF 176*144	F	16	53	66	113	133	170

Example:

Input 1280*1024 Output=640*480

Hratio = 1280/640 =2

Vratio = 1024/480 =2.1333

The decimation factor is 2 so 32/16.

Figure 35-5. Resize Examples

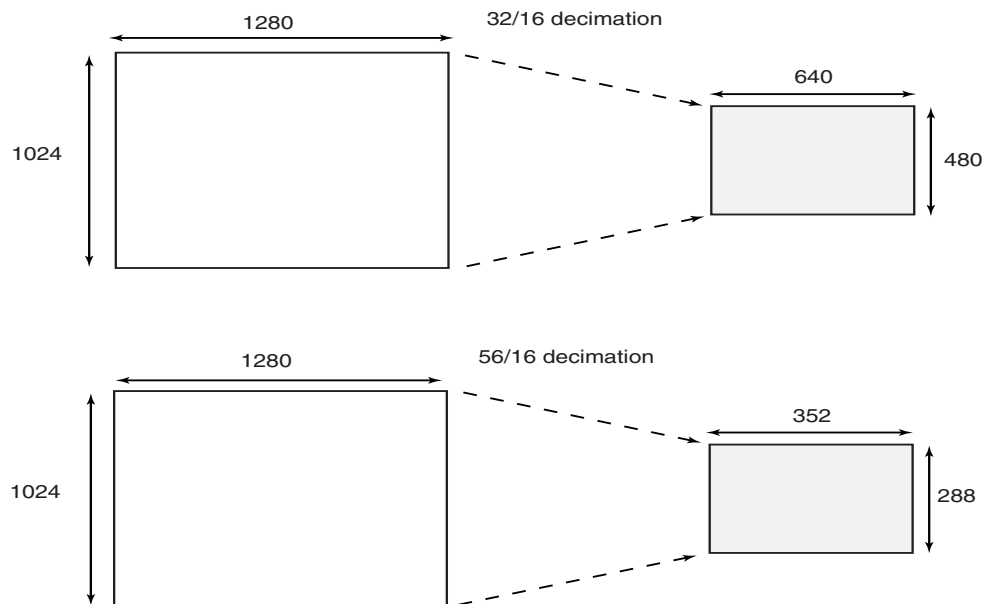

35.4.4.2 Color Space Conversion

This module converts YCrCb or YUV pixels to RGB color space. Clipping is performed to ensure that the samples value do not exceed the allowable range. The conversion matrix is defined below:

$$\begin{bmatrix} R \\ G \\ B \end{bmatrix} = \begin{bmatrix} C_0 & 0 & C_1 \\ C_0 & -C_2 & -C_3 \\ C_0 & C_4 & 0 \end{bmatrix} \times \begin{bmatrix} Y - Y_{off} \\ C_b - C_{boff} \\ C_r - C_{roff} \end{bmatrix}$$

Example of programmable value to convert YCrCb to RGB:

$$\begin{cases} R = 1,164 \cdot (Y - 16) + 1,596 \cdot (C_r - 128) \\ G = 1,164 \cdot (Y - 16) - 0,813 \cdot (C_r - 128) - 0,392 \cdot (C_b - 128) \\ B = 1,164 \cdot (Y - 16) + 2,107 \cdot (C_b - 128) \end{cases}$$

An example of programmable value to convert from YUV to RGB:

$$\begin{cases} R = Y + 1,596 \cdot V \\ G = Y - 0,394 \cdot U - 0,436 \cdot V \\ B = Y + 2,032 \cdot U \end{cases}$$

35.4.4.3 Memory Interface

Preview datapath contains a data formatter that converts 8:8:8 pixel to RGB 5:5:5 format compliant with 16-bit format of the LCD controller. In general, when converting from a color channel with more bits to one with fewer bits, formatter module discards the lower-order bits. Example: Converting from RGB 8:8:8 to RGB 5:6:5, it discards the three LSBs from the red and blue channels, and two LSBs from the green channel. When grayscale mode is enabled, two memory format are supported. One mode supports 2 pixels per word, and the other mode supports 1 pixel per word.

Table 35-8. Grayscale Memory Mapping Configuration for 12-bit Data

GS_MODE	DATA[31:24]	DATA[23:16]	DATA[15:8]	DATA[7:0]
0	P_0[11:4]	P_0[3:0], 0000	P_1[11:4]	P_1[3:0], 0000
1	P_0[11:4]	P_0[3:0], 0000	0	0

35.4.4.4 FIFO and DMA Features

Both preview and Codec datapaths contain FIFOs, asynchronous buffers that are used to safely transfer formatted pixels from Pixel clock domain to High Speed Bus (HSB) clock domain. A video arbiter is used to manage FIFO thresholds and triggers a relevant DMA request through the HSB master interface. Thus, depending on FIFO state, a specified length burst is asserted. Regarding HSB master interface, it supports Scatter DMA mode through linked list operation. This mode of operation improves flexibility of image buffer location and allows the user to allocate two or more frame buffers. The destination frame buffers are defined by a series of Frame Buffer Descriptors (FBD). Each FBD controls the transfer of one entire frame and then optionally loads a further FBD to switch the DMA operation at another frame buffer address. The FBD is defined by a series of two words. The first one defines the current frame buffer address, and the second defines the next FBD memory location. This DMA transfer mode is only available for preview datapath and is configured in the PPFBD register that indicates the memory location of the first FBD.

The primary FBD is programmed into the camera interface controller. The data to be transferred described by an FBD requires several burst access. In the example below, the use of 2 ping-pong frame buffers is described.

35.4.4.5 Example

The first FBD, stored at address 0x30000, defines the location of the first frame buffer.

Destination Address: frame buffer ID0 0x02A000

Next FBD address: 0x30010

Second FBD, stored at address 0x30010, defines the location of the second frame buffer.

Destination Address: frame buffer ID1 0x3A000

Transfer width: 32 bit

Next FBD address: 0x30000, wrapping to first FBD.

Using this technique, several frame buffers can be configured through the linked list. [Figure 35-6](#) illustrates a typical three frame buffer application. Frame n is mapped to frame buffer 0, frame n+1 is mapped to frame buffer 1, frame n+2 is mapped to Frame buffer 2, further frames wrap. A codec request occurs, and the full-size 4:2:2 encoded frame is stored in a dedicated memory space.

Figure 35-6. Three Frame Buffers Application and Memory Mapping

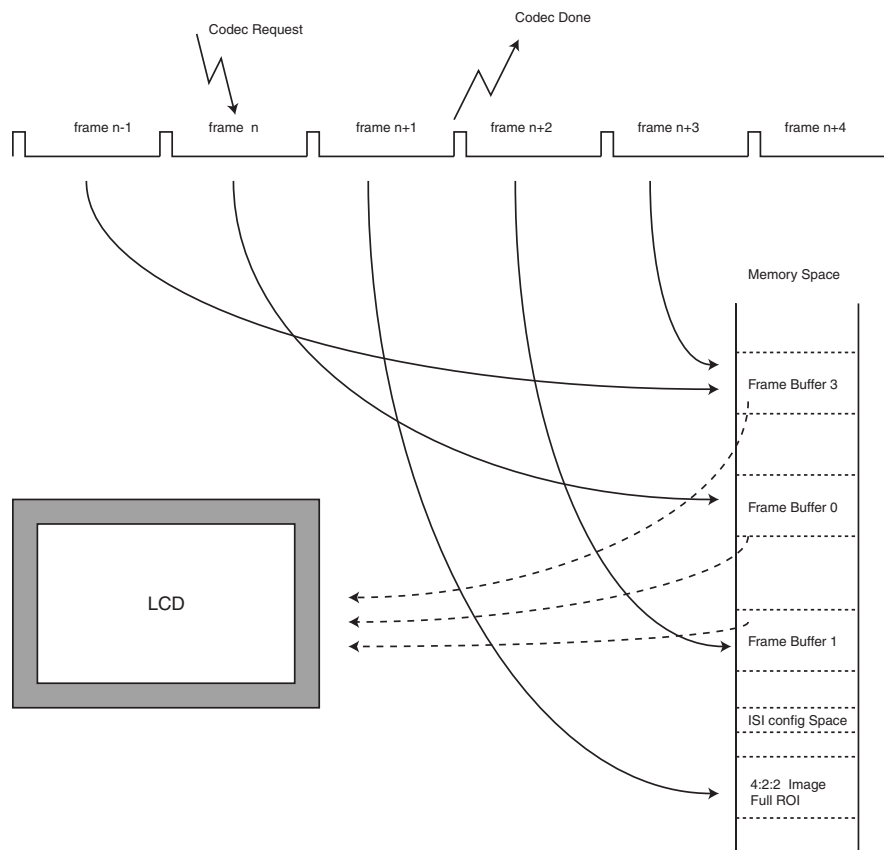

35.4.5 Codec Path

35.4.5.1 Color Space Conversion

Depending on user selection, this module can be bypassed so that input YCrCb stream is directly connected to the format converter module. If the RGB input stream is selected, this module converts RGB to YCrCb color space with the formulas given below:

$$\begin{bmatrix} Y \\ C_r \\ C_b \end{bmatrix} = \begin{bmatrix} C_0 & C_1 & C_2 \\ C_3 & -C_4 & -C_5 \\ -C_6 & -C_7 & C_8 \end{bmatrix} \times \begin{bmatrix} R \\ G \\ B \end{bmatrix} + \begin{bmatrix} Y_{off} \\ C_{r_{off}} \\ C_{b_{off}} \end{bmatrix}$$

An example of coefficients are given below:

$$\begin{cases} Y = 0,257 \cdot R + 0,504 \cdot G + 0,098 \cdot B + 16 \\ C_r = 0,439 \cdot R - 0,368 \cdot G - 0,071 \cdot B + 128 \\ C_b = -0,148 \cdot R - 0,291 \cdot G + 0,439 \cdot B + 128 \end{cases}$$

35.4.5.2 Memory Interface

Dedicated FIFO are used to support packed memory mapping. YCrCb pixel components are sent in a single 32-bit word in a contiguous space (packed). Data is stored in the order of natural scan lines. Planar mode is not supported.

35.4.5.3 DMA Features

Unlike preview datapath, codec datapath DMA mode does not support linked list operation. Only the CODEC_DMA_ADDR register is used to configure the frame buffer base address.

35.5 Image Sensor Interface (ISI) User Interface

Table 35-9. ISI Registers

Offset	Register Name	Register	Access	Reset Value
0x00	ISI Control 1 Register	CR1	Read/Write	0x00000002
0x04	ISI Control 2 Register	CR2	Read/Write	0x00000000
0x08	ISI Status Register	SR	Read	0x00000000
0x0C	ISI Interrupt Enable Register	IER	Write	0x00000000
0x10	ISI Interrupt Disable Register	IDR	Write	0x00000000
0x14	ISI Interrupt Mask Register	IMR	Read	0x00000000
0x18	Reserved	-	-	-
0x1C	Reserved	-	-	-
0x20	ISI Preview Size Register	PSIZE	Read/Write	0x00000000
0x24	ISI Preview Decimation Factor Register	PDECFA	Read/Write	0x00000010
0x28	ISI Preview Primary FBD Register	PPFBD	Read/Write	0x00000000
0x2C	ISI Codec DMA Base Address Register	CDBA	Read/Write	0x00000000
0x30	ISI CSC YCrCb To RGB Set 0 Register	Y2R_SET0	Read/Write	0x6832cc95
0x34	ISI CSC YCrCb To RGB Set 1 Register	Y2R_SET1	Read/Write	0x00007102
0x38	ISI CSC RGB To YCrCb Set 0 Register	R2Y_SET0	Read/Write	0x01324145
0x3C	ISI CSC RGB To YCrCb Set 1 Register	R2Y_SET1	Read/Write	0x01245e38
0x40	ISI CSC RGB To YCrCb Set 2 Register	R2Y_SET2	Read/Write	0x01384a4b
0x44-0xFC	Reserved	-	-	-

35.5.1 ISI Control 1 Register

Register Name: CR1

Access Type: Read/Write

Reset Value: 0x00000002

31	30	29	28	27	26	25	24
SFD							
23	22	21	20	19	18	17	16
SLD							
15	14	13	12	11	10	9	8
CODEC_EN	THMASK		FULL	-	FRATE		
7	6	5	4	3	2	1	0
CRC_SYNC	EMB_SYNC	-	PIXCLK_POL	VSYNC_POL	HSYNC_POL	DIS	RST

- **RST: Image sensor interface reset**

0: No action

1: Resets the image sensor interface.

- **DIS: Image sensor disable:**

0: Enable the image sensor interface.

1: Finish capturing the current frame and then shut down the module.

- **HSYNC_POL: Horizontal synchronization polarity**

0: HSYNC active high

1: HSYNC active low

- **VSYNC_POL: Vertical synchronization polarity**

0: VSYNC active high

1: VSYNC active low

- **PIXCLK_POL: Pixel clock polarity**

0: Data is sampled on rising edge of pixel clock

1: Data is sampled on falling edge of pixel clock

- **EMB_SYNC: Embedded synchronization**

0: Synchronization by HSYNC, VSYNC

1: Synchronization by embedded synchronization sequence SAV/EAV

- **CRC_SYNC: Embedded synchronization**

0: No CRC correction is performed on embedded synchronization

1: CRC correction is performed. if the correction is not possible, the current frame is discarded and the CRC_ERR is set in the status register.

- **FRATE: Frame rate [0..7]**

0: All the frames are captured, else one frame every FRATE+1 is captured.

- **FULL: Full mode is allowed**

0: Codec and preview datapaths are not working simultaneously

1: Both codec and preview datapaths are working simultaneously

- **THMASK: Threshold mask**

0: 4, 8 and 16 HSB bursts are allowed

1: 8 and 16 HSB bursts are allowed

2: Only 16 HSB bursts are allowed

- **CODEC_EN: Enable the codec path enable bit**

This bit always read as zero

0: The codec path is disabled

1: The codec path is enabled and the next frame is captured

- **SLD: Start of Line Delay**

SLD pixel clock periods to wait before the beginning of a line.

- **SFD: Start of Frame Delay**

SFD lines are skipped at the beginning of the frame.

35.5.2 ISI Control 2 Register

Register Name: CR2

Access Type: Read/Write

Reset Value: 0x0

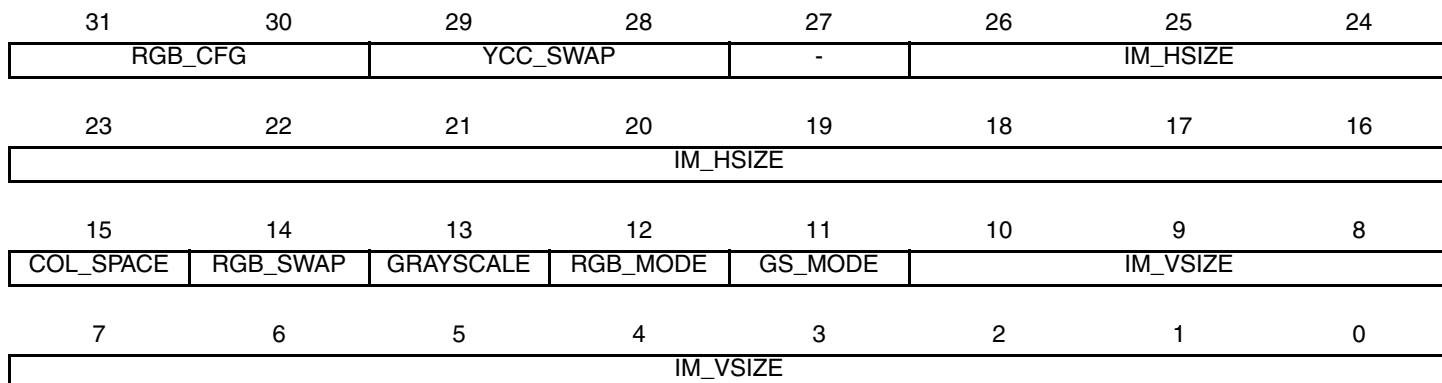

- **IM_VSIZE: Vertical size of the Image sensor [0..2047]**

Vertical size = IM_VSIZE + 1

- **GS_MODE**

0: 2 pixels per word

1: 1 pixel per word

- **RGB_MODE: RGB input mode**

0: RGB 8:8:8 24 bits

1: RGB 5:6:5 16 bits

- **GRAYSCALE**

0: Grayscale mode is disabled

1: Input image is assumed to be grayscale coded

- **RGB_SWAP**

0: D7 -> R7

1: D0 -> R7

The RGB_SWAP has no effect when the grayscale mode is enabled.

- **COL_SPACE: Color space for the image data**

0: YCbCr

1: RGB

- **IM_HSIZE: Horizontal size of the Image sensor [0..2047]**

Horizontal size = IM_HSIZE + 1

- **YCC_SWAP:** Defines the YCC image data

YCC_SWAP	Byte 0	Byte 1	Byte 2	Byte 3
00: Default	Cb(i)	Y(i)	Cr(i)	Y(i+1)
01: Mode1	Cr(i)	Y(i)	Cb(i)	Y(i+1)
10: Mode2	Y(i)	Cb(i)	Y(i+1)	Cr(i)
11: Mode3	Y(i)	Cr(i)	Y(i+1)	Cb(i)

- **RGB_CFG:** Defines RGB pattern when RGB_MODE is set to 1

RGB_CFG	Byte 0	Byte 1	Byte 2	Byte 3
00: Default	R/G(MSB)	G(LSB)/B	R/G(MSB)	G(LSB)/B
01: Mode1	B/G(MSB)	G(LSB)/R	B/G(MSB)	G(LSB)/R
10: Mode2	G(LSB)/R	B/G(MSB)	G(LSB)/R	B/G(MSB)
11: Mode3	G(LSB)/B	R/G(MSB)	G(LSB)/B	R/G(MSB)

If RGB_MODE is set to RGB 8:8:8, then RGB_CFG = 0 implies RGB color sequence, else it implies BGR color sequence.

35.5.3 ISI Status Register

Register Name: SR

Access Type: Read

Reset Value: 0x0

31	30	29	28	27	26	25	24
–	–	–	–	–	–	–	–
23	22	21	20	19	18	17	16
–	–	–	–	–	–	–	–
15	14	13	12	11	10	9	8
–	–	–	–	–	–	FR_OVR	FO_C_EMP
7	6	5	4	3	2	1	0
FO_P_EMP	FO_P_OVF	FO_C_OVF	CRC_ERR	CDC_STAT	SOFTRST	DIS	SOF

- **SOF: Start of frame**

0: No start of frame has been detected.

1: A start of frame has been detected.

- **DIS: Image Sensor Interface disable**

0: The image sensor interface is enabled.

1: The image sensor interface is disabled and stops capturing data. The DMA controller and the core can still read the FIFOs.

- **SOFTRST: Software reset**

0: Software reset not asserted or not completed

1: Software reset has completed successfully

- **CDC_STAT: Codec Request Status**

0: Codec request has been asserted

1: Codec request has been serviced

- **CRC_ERR: CRC synchronization error**

0: No crc error in the embedded synchronization frame (SAV/EAV)

1: The CRC_SYNC is enabled in the control register and an error has been detected and not corrected. The frame is discarded and the ISI waits for a new one.

- **FO_C_OVF: FIFO codec overflow**

0: No overflow

1: An overrun condition has occurred in input FIFO on the codec path. The overrun happens when the FIFO is full and an attempt is made to write a new sample to the FIFO.

- **FO_P_OVF: FIFO preview overflow**

0: No overflow

1: An overrun condition has occurred in input FIFO on the preview path. The overrun happens when the FIFO is full and an attempt is made to write a new sample to the FIFO.

- **FO_P_EMP**

0: The DMA has not finished transferring all the contents of the preview FIFO.

1: The DMA has finished transferring all the contents of the preview FIFO.

- **FO_C_EMP**

0: The DMA has not finished transferring all the contents of the codec FIFO.

1: The DMA has finished transferring all the contents of the codec FIFO.

- **FR_OVR: Frame overrun**

0: No frame overrun.

1: Frame overrun, the current frame is being skipped because a vsync signal has been detected while flushing FIFOs.

35.5.4 Interrupt Enable Register

Register Name: IER

Access Type: Write

Reset Value: 0x0

31	30	29	28	27	26	25	24
–	–	–	–	–	–	–	–
23	22	21	20	19	18	17	16
–	–	–	–	–	–	–	–
15	14	13	12	11	10	9	8
–	–	–	–	–	–	FR_OVR	FO_C_EMP
7	6	5	4	3	2	1	0
FO_P_EMP	FO_P_OVF	FO_C_OVF	CRC_ERR	–	SOFRST	DIS	SOF

- **SOF: Start of Frame**

1: Enables the Start of Frame interrupt.

- **DIS: Image Sensor Interface disable**

1: Enables the DIS interrupt.

- **SOFRST: Soft Reset**

1: Enables the Soft Reset Completion interrupt.

- **CRC_ERR: CRC synchronization error**

1: Enables the CRC_SYNC interrupt.

- **FO_C_OVF: FIFO codec Overflow**

1: Enables the codec FIFO overflow interrupt.

- **FO_P_OVF: FIFO preview Overflow**

1: Enables the preview FIFO overflow interrupt.

- **FO_P_EMP**

1: Enables the preview FIFO empty interrupt.

- **FO_C_EMP**

1: Enables the codec FIFO empty interrupt.

- **FR_OVR: Frame overrun**

1: Enables the Frame overrun interrupt.

35.5.5 ISI Interrupt Disable Register

Register Name: IDR

Access Type: Write

Reset Value: 0x0

31	30	29	28	27	26	25	24
–	–	–	–	–	–	–	–
23	22	21	20	19	18	17	16
–	–	–	–	–	–	–	–
15	14	13	12	11	10	9	8
–	–	–	–	–	–	FR_OVR	FO_C_EMP
7	6	5	4	3	2	1	0
FO_P_EMP	FO_P_OVF	FO_C_OVF	CRC_ERR	–	SOFRST	DIS	SOF

- **SOF: Start of Frame**

1: Disables the Start of Frame interrupt.

- **DIS: Image Sensor Interface disable**

1: Disables the DIS interrupt.

- **SOFRST**

1: Disables the soft reset completion interrupt.

- **CRC_ERR: CRC synchronization error**

1: Disables the CRC_SYNC interrupt.

- **FO_C_OVF: FIFO codec overflow**

1: Disables the codec FIFO overflow interrupt.

- **FO_P_OVF: FIFO preview overflow**

1: Disables the preview FIFO overflow interrupt.

- **FO_P_EMP**

1: Disables the preview FIFO empty interrupt.

- **FO_C_EMP**

1: Disables the codec FIFO empty interrupt.

- **FR_OVR: Frame overrun**

1: Disables frame overrun interrupt.

35.5.6 ISI Interrupt Mask Register

Register Name: IMR

Access Type: Read

Reset Value: 0x0

31	30	29	28	27	26	25	24
–	–	–	–	–	–	–	–
23	22	21	20	19	18	17	16
–	–	–	–	–	–	–	–
15	14	13	12	11	10	9	8
–	–	–	–	–	–	FR_OVR	FO_C_EMP
7	6	5	4	3	2	1	0
FO_P_EMP	FO_P_OVF	FO_C_OVF	CRC_ERR	–	SOFRST	DIS	SOF

- **SOF: Start of Frame**

0: The Start of Frame interrupt is disabled.

1: The Start of Frame interrupt is enabled.

- **DIS: Image sensor interface disable**

0: The DIS interrupt is disabled.

1: The DIS interrupt is enabled.

- **SOFRST**

0: The soft reset completion interrupt is enabled.

1: The soft reset completion interrupt is disabled.

- **CRC_ERR: CRC synchronization error**

0: The CRC_SYNC interrupt is disabled.

1: The CRC_SYNC interrupt is enabled.

- **FO_C_OVF: FIFO codec overflow**

0: The codec FIFO overflow interrupt is disabled.

1: The codec FIFO overflow interrupt is enabled.

- **FO_P_OVF: FIFO preview overflow**

0: The preview FIFO overflow interrupt is disabled.

1: The preview FIFO overflow interrupt is enabled.

- **FO_P_EMP**

0: The preview FIFO empty interrupt is disabled.

1: The preview FIFO empty interrupt is enabled.

- **FO_C_EMP**

0: The codec FIFO empty interrupt is disabled.



1: The codec FIFO empty interrupt is enabled.

- **FR_OVR: Frame Overrun**

0: The frame overrun interrupt is disabled.

1: The frame overrun interrupt is enabled.

35.5.7 ISI Preview Size Register

Register Name: PSIZE

Access Type: Read/Write

Reset Value: 0x0

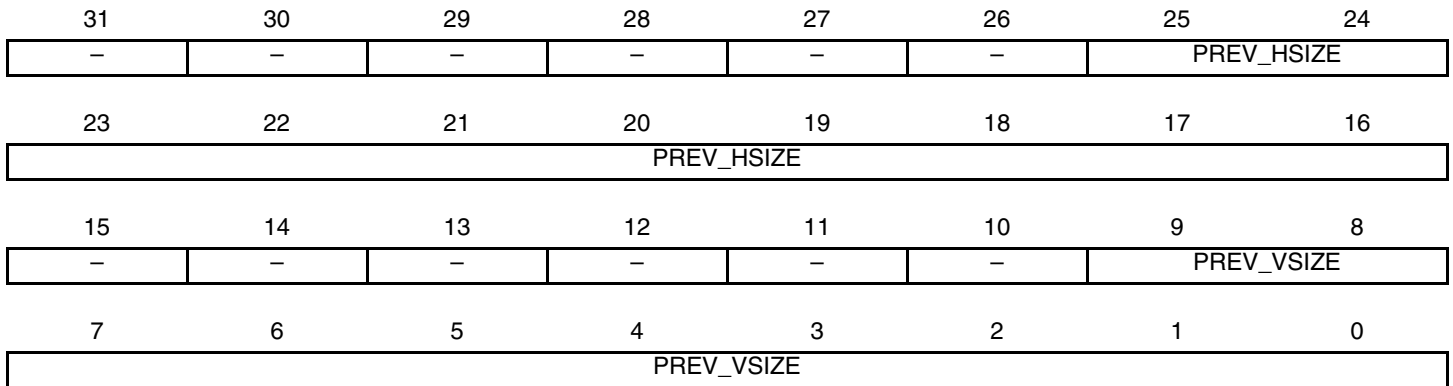

- **PREV_VSIZE: Vertical size for the preview path**

Vertical Preview size = PREV_VSIZE + 1 (480 max)

- **PREV_HSIZE: Horizontal size for the preview path**

Horizontal Preview size = PREV_HSIZE + 1 (640 max)

35.5.8 ISI Preview Decimation Factor Register

Register Name: PDEC_F

Access Type: Read/Write

Reset Value: 0x00000010

31	30	29	28	27	26	25	24
-	-	-	-	-	-	-	-
23	22	21	20	19	18	17	16
-	-	-	-	-	-	-	-
15	14	13	12	11	10	9	8
-	-	-	-	-	-	-	-
7	6	5	4	3	2	1	0
DEC_FACTOR							

• **DEC_FACTOR: Decimation factor**

DEC_FACTOR is 8-bit width, range is from 16 to 255. Values from 0 to 16 do not perform any decimation.

35.5.9 ISI Preview Primary FBD Register

Register Name: PPFBD

Access Type: Read/Write

Reset Value: 0x0

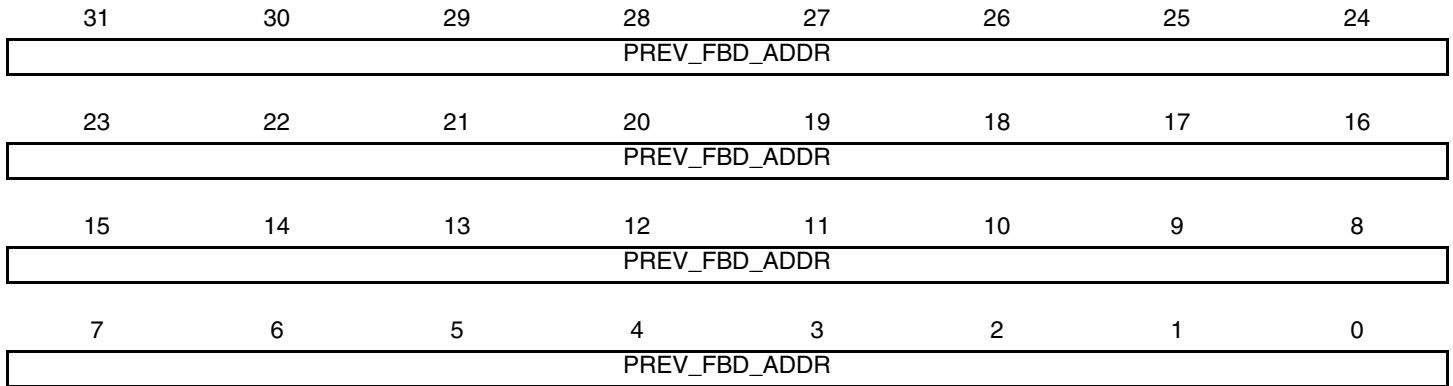

- **PREV_FBD_ADDR: Base address for preview frame buffer descriptor**

Written with the address of the start of the preview frame buffer queue, reads as a pointer to the current buffer being used. Forced to word alignment, ie the 2 lowest bits always read zero.

35.5.10 ISI Codec DMA Base Address Register

Register Name: CDBA

Access Type: Read/Write

Reset Value: 0x0

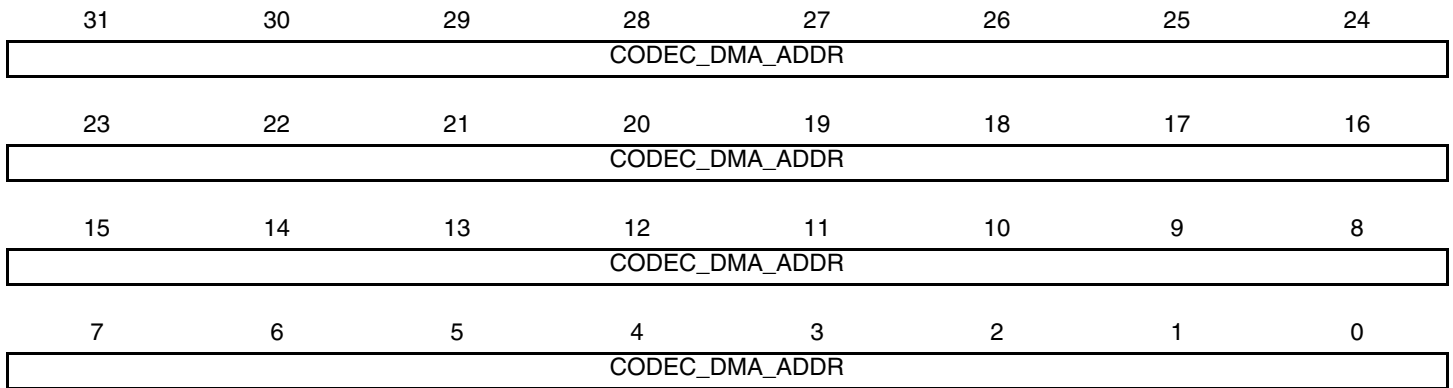

• **CODEC_DMA_ADDR: Base address for codec DMA**

This register contains codec datapath start address of buffer location. Forced to word alignment, ie the 2 lowest bits always read zero.

35.5.11 ISI Color Space Conversion YCrCb to RGB Set 0 Register

Register Name: Y2R_SET0

Access Type: Read/Write

Reset Value: 0x6832cc95

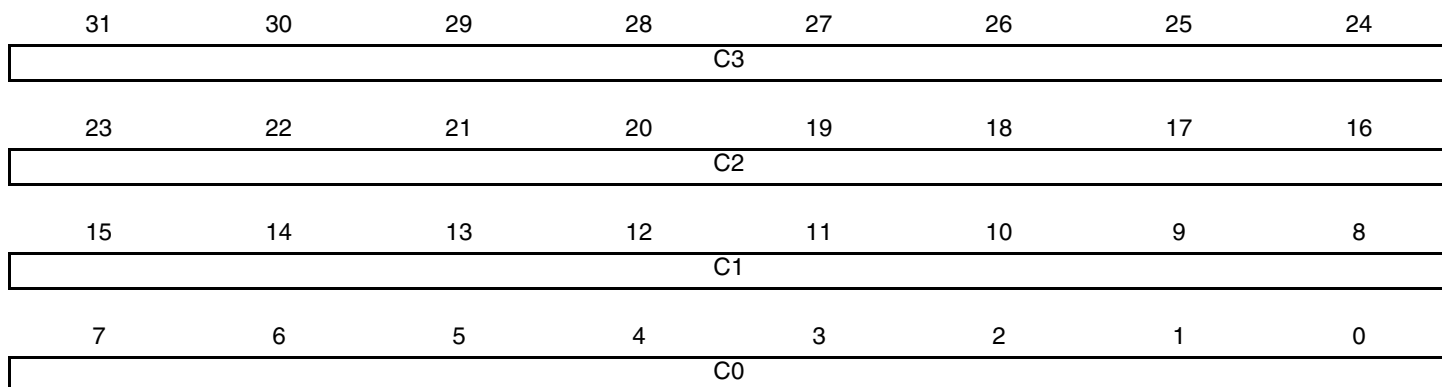

- **C3 : Color Space Conversion Matrix Coefficient C3**

C3 element, default step is 1/128, ranges from 0 to 255/128

- **C2 : Color Space Conversion Matrix Coefficient C2**

C2 element, default step is 1/128, ranges from 0 to 255/128

- **C1 : Color Space Conversion Matrix Coefficient C1**

C1 element, default step is 1/128, ranges from 0 to 255/128

- **C0 : Color Space Conversion Matrix Coefficient C0**

C0 element, default step is 1/128, ranges from 0 to 255/128

35.5.12 ISI Color Space Conversion YCrCb to RGB Set 1 Register

Register Name: Y2R_SET1

Access Type: Read/Write

Reset Value: 0x00007102

31	30	29	28	27	26	25	24
–	–	–	–	–	–	–	–
23	22	21	20	19	18	17	16
–	–	–	–	–	–	–	–
15	14	13	12	11	10	9	8
–	Cboff	Croff	Yoff	–	–	–	C4

C4							
----	--	--	--	--	--	--	--

- C4: Color Space Conversion Matrix coefficient C4**
 C4 element default step is 1/128, ranges from 0 to 512/128
- Yoff: Color Space Conversion Luminance default offset**
 0: No offset
 1: Offset = 128
- Croff: Color Space Conversion Red Chrominance default offset**
 0: No offset
 1: Offset = 16
- Cboff: Color Space Conversion Blue Chrominance default offset**
 0: No offset
 1: Offset = 16

35.5.13 ISI Color Space Conversion RGB to YCrCb Set 0 Register

Register Name: R2Y_SET0

Access Type: Read/Write

Reset Value: 0x01324145

31	30	29	28	27	26	25	24
-	-	-	-	-	-	-	Roff
23	22	21	20	19	18	17	16
-	C2						
15	14	13	12	11	10	9	8
-	C1						
7	6	5	4	3	2	1	0
-	C0						

- **C0: Color Space Conversion Matrix coefficient C0**

C0 element default step is 1/256, from 0 to 127/256

- **C1: Color Space Conversion Matrix coefficient C1**

C1 element default step is 1/128, from 0 to 127/128

- **C2: Color Space Conversion Matrix coefficient C2**

C2 element default step is 1/512, from 0 to 127/512

- **Roff: Color Space Conversion Red component offset**

0: No offset

1: Offset = 16

35.5.14 ISI Color Space Conversion RGB to YCrCb Set 1 Register

Register Name: R2Y_SET1

Access Type: Read/Write

Reset Value: 0x01245e38

31	30	29	28	27	26	25	24
-	-	-	-	-	-	-	Goff
23	22	21	20	19	18	17	16
-	C5						
15	14	13	12	11	10	9	8
-	C4						
7	6	5	4	3	2	1	0
-	C3						

- C3: Color Space Conversion Matrix coefficient C3**
 C0 element default step is 1/128, ranges from 0 to 127/128
- C4: Color Space Conversion Matrix coefficient C4**
 C1 element default step is 1/256, ranges from 0 to 127/256
- C5: Color Space Conversion Matrix coefficient C5**
 C1 element default step is 1/512, ranges from 0 to 127/512
- Goff: Color Space Conversion Green component offset**
 0: No offset
 1: Offset = 128

35.5.15 ISI Color Space Conversion RGB to YCrCb Set 2 Register

Register Name: R2Y_SET2

Access Type: Read/Write

Reset Value: 0x01384a4b

31	30	29	28	27	26	25	24
-	-	-	-	-	-	-	Boff
23	22	21	20	19	18	17	16
-	C8						
15	14	13	12	11	10	9	8
-	C7						
7	6	5	4	3	2	1	0
-	C6						

- **C6: Color Space Conversion Matrix coefficient C6**

C6 element default step is 1/512, ranges from 0 to 127/512

- **C7: Color Space Conversion Matrix coefficient C7**

C7 element default step is 1/256, ranges from 0 to 127/256

- **C8: Color Space Conversion Matrix coefficient C8**

C8 element default step is 1/128, ranges from 0 to 127/128

- **Boff: Color Space Conversion Blue component offset**

0: No offset

1: Offset = 128

36. Debug and Test

36.1 Features

- IEEE1149.1 compliant JTAG and boundary scan
- Direct memory access and programming capabilities through JTAG interface
- Extensive On-Chip Debug features in compliance with IEEE-ISTO 5001-2003 (Nexus 2.0) Class 3
- Auxiliary port for high-speed trace information
- Hardware support for 6 Program and 2 data breakpoints
- Unlimited number of software breakpoints supported
- Advanced Program, Data, Ownership, and Watchpoint trace supported

36.2 JTAG Interface

Access to debug and test features is provided through a IEEE1149.1 compliant JTAG interface, using the pins shown in [Table 36-1 on page 756](#).

The JTAG is a synchronous, serial protocol, which allows several devices on a circuit board to be accessed through a common JTAG port. The clock signal TCK and control signal TMS is common to all devices, while the data output TDO is chained to the data input TDI of the next device in the JTAG chain, effectively forming one long scan chain. Devices are addressed through their position in the JTAG chain.

Each JTAG device contains a TAP controller, which can be navigated through the TMS pin. The state of the TAP controller determines whether the serial data on TDI is a JTAG instruction or JTAG data. A number of serial data registers can be selected according to which JTAG instruction is loaded.

Table 36-1. JTAG pins

Pin	Direction	Description
TRST_N	Input	Asynchronous reset for the TAP controller and JTAG registers
TCK	Input	Test Clock. Data is driven on falling edge, sampled on rising edge.
TMS	Input	Test Mode Select
TDI	Input	Test Data In
TDO	Output	Test Data Out

The AVR32 JTAG has a 5-bit instruction register, which selects data registers of varying length. The implemented set of JTAG instructions provides the following capabilities:

- IEEE1149.1 compliant boundary-scan for testing interconnections between devices on a PCB.
- Internal and external memory programming
- Access to on-chip debug mechanisms
- Access to production test mechanisms

Production test specific features are described only in the Test and Programming Technical Reference Manual. Other features are additionally introduced below.

Figure 36-1. AVR32 JTAG connections

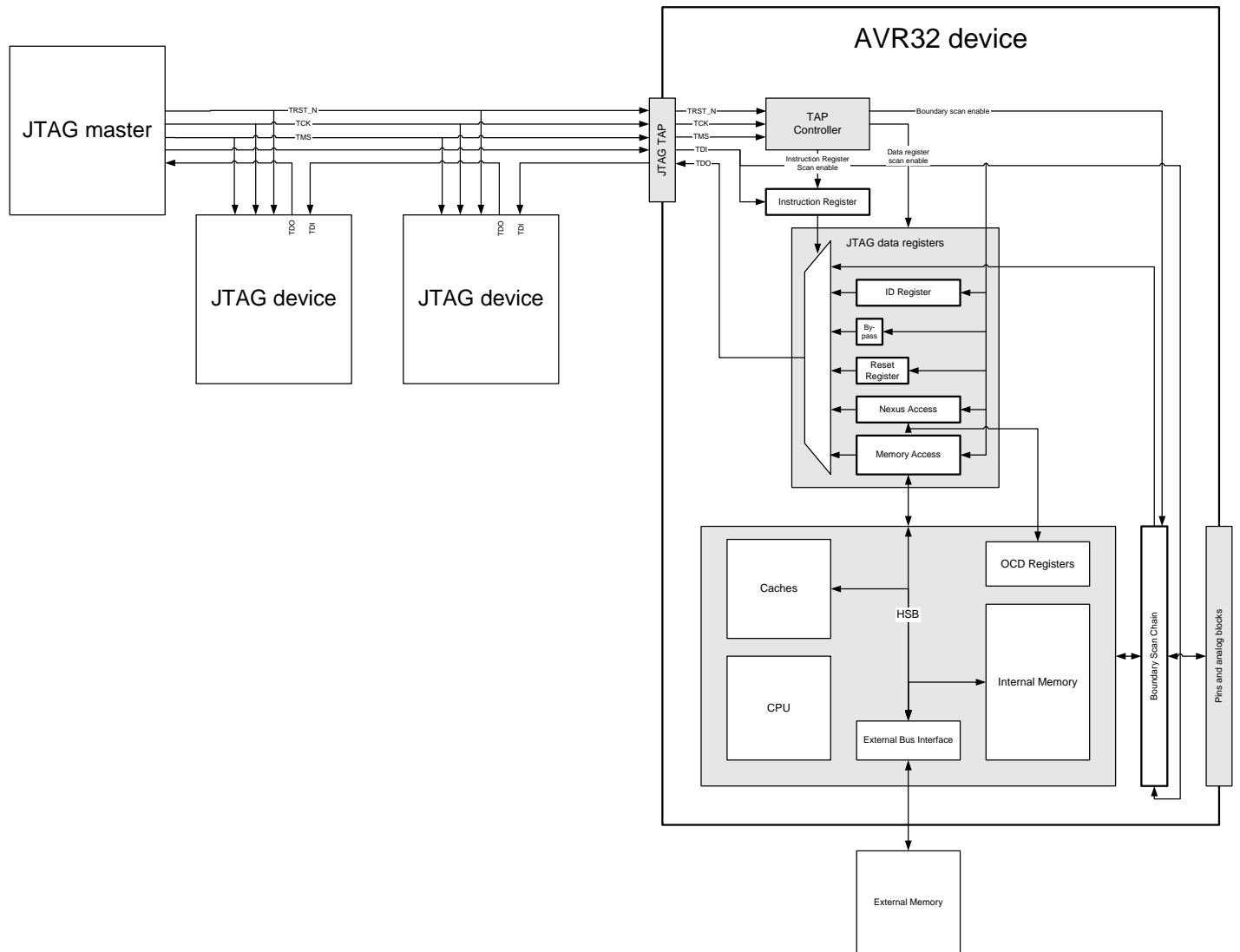

36.3 Public JTAG instructions

The following public (standard-defined) JTAG instructions are provided:

- IDCODE
- SAMPLE_PRELOAD
- EXTEST
- INTEST
- RUNBIST
- CLAMP
- BYPASS

The IDCODE is the default instruction loaded into the JTAG on power-up or after a JTAG reset. This selects the 32-bit JTAG IDCODE register, unique to each JTAG device. For AT32AP7001

this code is 0xR1E8203F, where R is the revision number of the device: Rev A = 0x0, B = 0x1, etc.

BYPASS selects the 1-bit bypass register as data register. Devices in a JTAG chain should normally be placed in BYPASS when not being addressed by the JTAG master.

The other instructions are used by boundary-scan, which allows testing PCB interconnections by scanning known data to the device pins, or sampling data driven from other circuits on the PCB. For operation of these instructions, please see the Test and Programming Technical Reference Manual.

36.4 Memory programming

The MEMORY_ACCESS JTAG Instruction gives the user access to the HSB bus through the JTAG interface. The physical address and the direction bit (read/write) is scanned into the JTAG, followed by scanning out the read data or scanning in the write data, depending on the direction of the transfer. Any physical memory address can be read or written, allowing internal memories to be written in the same way as when accessed by the CPU. Similarly, external memories can be accessed through the External Bus Interface (EBI). A polling mechanism provides the JTAG master with status information, indicating when the memory operation is complete.

The MEMORY_BLOCK_ACCESS command allows for a burst mode memory access through JTAG. This command automatically repeats a previous MEMORY_ACCESS command, with automatic incrementation of the address. Thus only data needs to be scanned in or out, giving negligible protocol overhead on the JTAG interface.

The JTAG master can use the CRC check feature described in [Section 36.5.1.6 on page 761](#) to automatically calculate the CRC-32 value of the programmed memory contents, to ensure that no transmission or programming errors have occurred.

When loading a new program to memory, the CPU should be kept reset by the AVR_RESET JTAG command. If the CPU executes a partially loaded program, unpredictable results may occur, and the program may be corrupted.

36.5 Debugging

Debugging on the AT32AP7001 is facilitated by a powerful On-Chip Debug (OCD) system. The user accesses this through an external debug tool which connects to the JTAG port and the Auxiliary (AUX) port. The AUX port is primarily used for trace functions, and a JTAG-based debugger is sufficient for basic debugging.

The debug system is based on the Nexus 2.0 standard, class 3, which includes:

- Basic run-time control
- Program breakpoints
- Data breakpoints
- Program trace
- Ownership trace
- Data trace
- Run-time direct memory access

In addition to the mandatory Nexus debug features, the AT32AP7001 implements several useful OCD features, such as:

- Debug Communication Channel between CPU and JTAG
- Run-time PC monitoring
- CRC checking
- NanoTrace
- Software Quality Analysis support

The OCD features are controlled by OCD registers, which can be accessed by JTAG when the NEXUS_ACCESS JTAG instruction is loaded. The CPU can also access OCD registers directly using mtdr/mfdr instructions in any privileged mode. The OCD registers are implemented based on the recommendations in the Nexus 2.0 standard, and are detailed in the OCD Technical Reference Manual.

Figure 36-2. On-Chip Debug block diagram

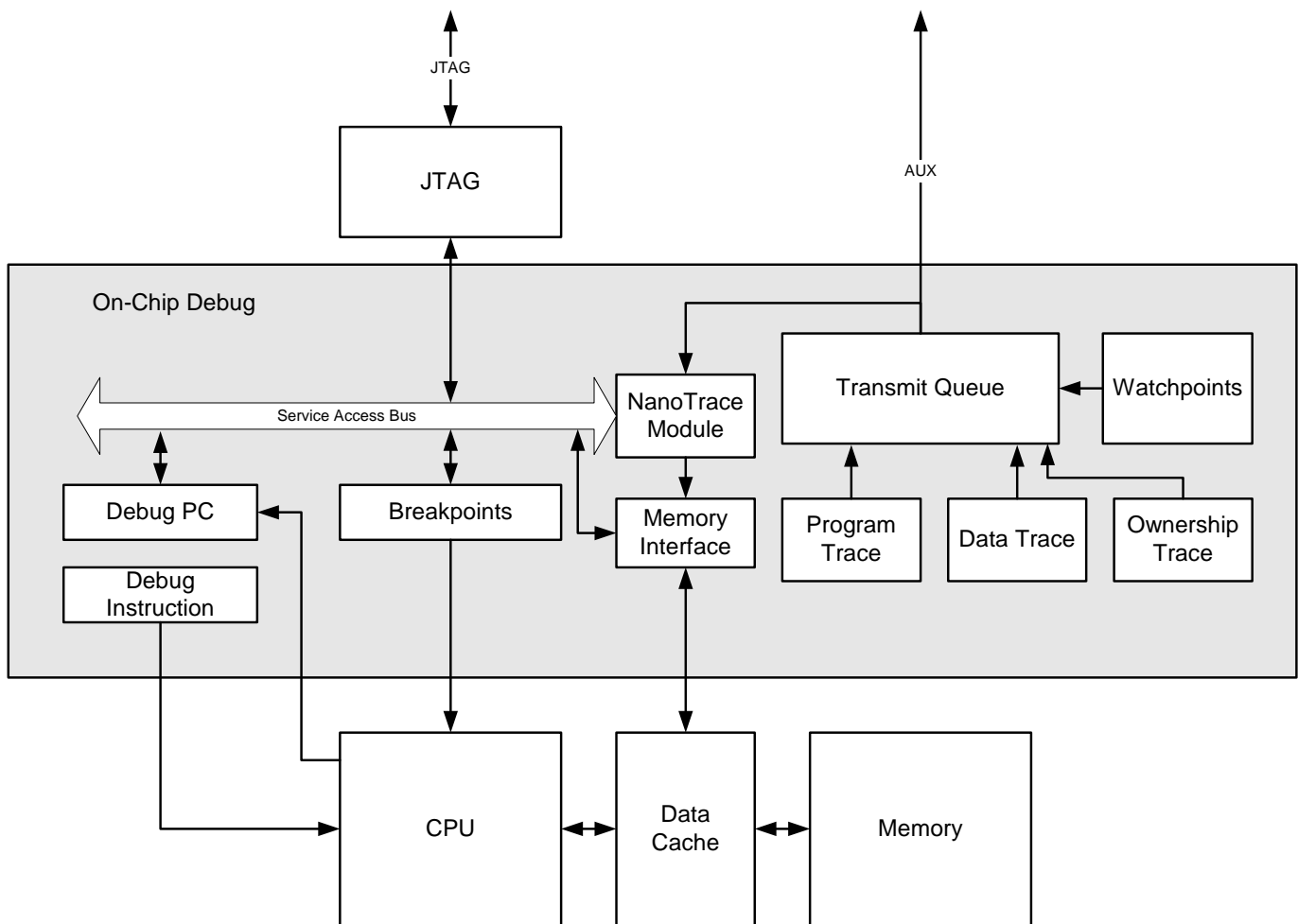

36.5.1 JTAG-based debug features

A debugger can control all OCD features by writing OCD registers over the JTAG interface. Many of these do not depend on output on the AUX port, allowing a JTAG-based debugger to be used.

A JTAG-based debugger should connect to the device through a standard 10-pin IDC connector as described in the OCD Technical Reference Manual.

Figure 36-3. JTAG-based debugger

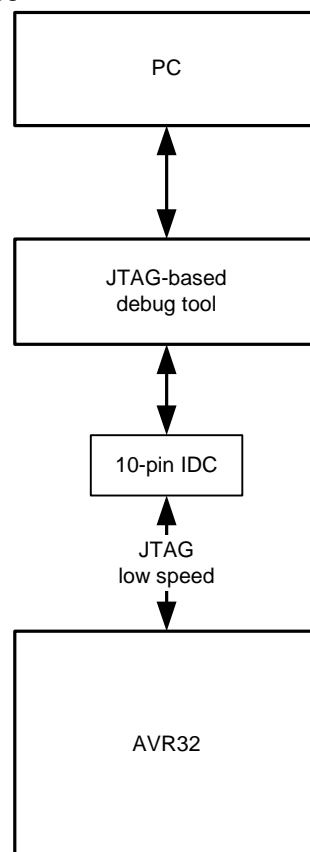

36.5.1.1 Debug Communication Channel

The Debug Communication Channel (DCC) consists of a pair of OCD registers with associated handshake logic, accessible to both CPU and JTAG. The registers can be used to exchange data between the CPU and the JTAG master, both runtime as well as in debug mode.

36.5.1.2 Breakpoints

One of the most fundamental debug features is the ability to halt the CPU, to examine registers and the state of the system. This is accomplished by breakpoints, of which many types are available:

- Unconditional breakpoints halt the CPU immediately. Breakpoints are set by writing the OCD registers directly via JTAG.
- Program breakpoints halt the CPU when a specific address in the program is executed.
- Data breakpoints halt the CPU when a specific memory address is read or written, allowing variables to be watched.
- Software breakpoints halt the CPU when the breakpoint instruction is executed.

When a breakpoint triggers, the CPU enters debug mode, and the D bit in the status register is set. This is a privileged mode with dedicated return address and return status registers. All privileged instructions are permitted. Debug mode can be entered as either OCD Mode, running instructions from JTAG, or Monitor Mode, running instructions from program memory.

36.5.1.3 *OCD Mode*

When a breakpoint triggers, the CPU enters OCD mode, and instructions are fetched from the Debug Instruction OCD register. Each time this register is written by JTAG, the instruction is executed, allowing the JTAG to execute CPU instructions directly. The JTAG master can e.g. read out the register file by issuing mtdr instructions to the CPU, writing each register to the Debug Communication Channel OCD registers.

36.5.1.4 *Monitor Mode*

Since the OCD registers are directly accessible by the CPU, it is possible to build a software-based debugger that runs on the CPU itself. Setting the Monitor Mode bit in the Development Control register causes the CPU to enter Monitor Mode instead of OCD mode when a breakpoint triggers. Monitor Mode is similar to OCD mode, except that instructions are fetched from the debug exception vector in regular program memory, instead of issued by JTAG.

36.5.1.5 *Direct Memory Access*

Direct memory access can be accomplished as described above using the MEMORY_ACCESS JTAG instruction. It is not necessary to halt the CPU when using this mechanism, so the memories can be examined on-the-fly without disturbing the program. It is also possible to access memory by using OCD registers, as described in the Nexus standard.

36.5.1.6 *Cyclic Redundancy Check (CRC)*

The memory access OCD registers can additionally be used to automatically calculate the CRC of a block of data in memory. The OCD will then read out each word in the specified memory block and report the CRC32-value in an OCD register.

36.5.1.7 *NanoTrace*

NanoTrace is an AVR32-specific feature, in which trace data is output to memory instead of the AUX port. This allows the trace data to be extracted by JTAG MEMORY_ACCESS, enabling trace features for JTAG-based debuggers. The user must write OCD registers to configure the address and size of the memory block to be used for NanoTrace. The NanoTrace buffer can be anywhere in the physical address range, including internal and external RAM, through the EBI. This area may not be used by the application running on the CPU. The NanoTrace Access Error protection mechanism can trigger a reset or breakpoint if the application erroneously accesses the NanoTrace buffer.

36.5.1.8 *Program Counter monitoring*

Normally, the CPU would need to be halted for a JTAG-based debugger to examine the current PC value. However, the AT32AP7001 also provides a Debug Program Counter OCD register, where the debugger can continuously read the current PC without affecting the CPU. This allows the debugger to generate a simple statistic of the time spent in various areas of the code, easing code optimization.

36.5.2 AUX-based debug features

Utilizing the Auxiliary (AUX) port gives access to a wide range of advanced debug features. Of prime importance are the trace features, which allow an external debugger to receive continuous information on the program execution in the CPU. Additionally, Event In and Event Out pins allow external events to be correlated with the program flow.

The AUX port contains a number of pins, as shown in [Table 36-2](#). These are multiplexed with PIO lines, and must explicitly be enabled by writing OCD registers before the debug session starts. The AUX port is mapped to two different locations, selectable by OCD Registers, minimizing the chance that the AUX port will need to be shared with an application.

Debug tools utilizing the AUX port should connect to the device through a Nexus-compliant Micror-38 connector, as described in the OCD Technical Reference manual. This connector includes the JTAG signals and the RESET_N pin, giving full access to the programming and debug features in the device.

Table 36-2. Auxiliary port signals

Signal	Direction	Description
MCKO	Output	Trace data output clock
MDO[5:0]	Output	Trace data output
MSEO[1:0]	Output	Trace frame control
EVTI_N	Input	Event In
EVTO_N	Output	Event Out

Figure 36-4. AUX+JTAG based debugger

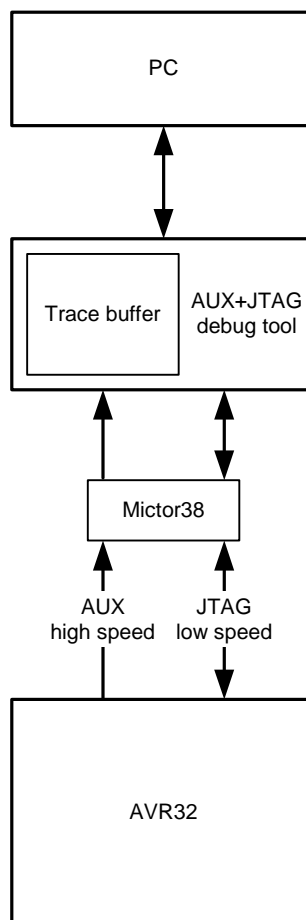

36.5.2.1 Trace operation

Trace features are enabled by writing OCD registers by JTAG. The OCD extracts the trace information from the CPU, compresses this information and formats it into variable-length messages according to the Nexus standard. The messages are buffered in a 16-frame transmit queue, and are output on the AUX port one frame at a time.

The trace features can be configured to be very selective, to reduce the bandwidth on the AUX port. In case the transmit queue overflows, error messages are produced to indicate loss of data. The transmit queue module can optionally be configured to halt the CPU when an overflow occurs, to prevent the loss of messages, at the expense of longer run-time for the program.

36.5.2.2 Program Trace

Program trace allows the debugger to continuously monitor the program execution in the CPU. Program trace messages are generated for every branch in the program, and contains compressed information, which allows the debugger to correlate the message with the source code to identify the branch instruction and target address.

36.5.2.3 Data Trace

Data trace outputs a message every time a specific location is read or written. The message contains information about the type (read/write) and size of the access, as well as the address and data of the accessed location. The AT32AP7001 contains two data trace channels, each of which are controlled by a pair of OCD registers which determine the range of addresses (or single address) which should produce data trace messages.

36.5.2.4 Ownership Trace

Program and data trace operate on virtual addresses. In cases where an operating system runs several processes in overlapping virtual memory segments, the Ownership Trace feature can be used to identify the process switch. When the OS activates a process, it will write the process ID number to an OCD register, which produces an Ownership trace message, allowing the debugger to switch context for the subsequent program and data trace messages. As the use of this feature depends on the software running on the CPU, it can also be used to extract other types of information from the system.

36.5.2.5 Watchpoint messages

The breakpoint modules normally used to generate program and data breakpoints can also be used to generate Watchpoint messages, allowing a debugger to monitor program and data events without halting the CPU. Watchpoints can be enabled independently of breakpoints, so a breakpoint module can optionally halt the CPU when the trigger condition occurs. Data trace modules can also be configured to produce watchpoint messages instead of regular data trace messages.

36.5.2.6 Event In and Event Out pins

The AUX port also contains an Event In pin (EVTI_N) and an Event Out pin (EVTO_N). EVTI_N can be used to trigger a breakpoint when an external event occurs. It can also be used to trigger specific program and data trace synchronization messages, allowing an external event to be correlated to the program flow.

When the CPU enters debug mode, a Debug Status message is transmitted on the trace port. All trace messages can be timestamped when they are received by the debug tool. However, due to the latency of the transmit queue buffering, the timestamp will not be 100% accurate. To improve this, EVTO_N can toggle every time a message is inserted into the transmit queue, allowing trace messages to be timestamped precisely. EVTO_N can also toggle when a breakpoint module triggers, or when the CPU enters debug mode, for any reason. This can be used to measure precisely when the respective internal event occurs.

36.5.2.7 Software Quality Analysis (SQA)

Software Quality Analysis (SQA) deals with two important issues regarding embedded software development. *Code coverage* involves identifying untested parts of the embedded code, to improve test procedures and thus the quality of the released software. *Performance analysis* allows the developer to precisely quantify the time spent in various parts of the code, allowing bottlenecks to be identified and optimized.

Program trace must be used to accomplish these tasks without instrumenting (altering) the code to be examined. However, traditional program trace cannot reconstruct the current PC value without correlating the trace information with the source code, which cannot be done on-the-fly.

This limits program trace to a relatively short time segment, determined by the size of the trace buffer in the debug tool.

The OCD system in AT32AP7001 extends program trace with SQA capabilities, allowing the debug tool to reconstruct the PC value on-the-fly. Code coverage and performance analysis can thus be reported for an unlimited execution sequence.

37. Boot Sequence

This chapter summarizes the boot sequence of the AT32AP7001. The behaviour after power-up is controlled by the Power Manager.

37.1 Starting of clocks

After power-up, the device will be held in a reset state by the Power-On Reset circuitry, until the power has stabilized throughout the device. Once the power has stabilized, the device will use the XIN0 pin as clock source. XIN0 can be connected either to an external clock, or a crystal. The OSCEN_N pin is connected either to VDD or GND to inform the Power Manager on how the XIN0 pin is connected. If XIN0 receives a signal from a crystal, dedicated circuitry in the Power Manager keeps the part in a reset state until the oscillator connected to XIN0 has settled. If XIN0 receives an external clock, no such settling delay is applied.

On system start-up, the PLLs are disabled. All clocks to all modules are running. No clocks have a divided frequency, all parts of the system receive a clock with the same frequency as the XIN0 clock.

37.2 Fetching of initial instructions

After reset has been released, the AVR32AP CPU starts fetching instructions from the reset address, which is 0xA000_0000. This address lies in the P2 segment, which is non-translated, non-cacheable, and permanently mapped to the physical address range 0x0000_0000 to 0x2000_0000. This means that the instruction being fetched from virtual address 0xA000_0000 is being fetched from physical address 0x0000_0000. Physical address 0x0000_0000 is mapped to EBI SRAM CS0. This is the external memory the device boots from.

The code read from the SRAM CS0 memory is free to configure the system to use for example the PLLs, to divide the frequency of the clock routed to some of the peripherals, and to gate the clocks to unused peripherals.

38. Mechanical Characteristics - TBD

38.1 AVR32AP7001

38.1.1 Thermal Considerations

38.1.1.1 Thermal Data

Table 38-1 summarizes the thermal resistance data depending on the package.

Table 38-1. Thermal Resistance Data

Symbol	Parameter	Condition	Package	Typ	Unit
θ_{JA}	Junction-to-ambient thermal resistance	Still Air	QFP208	TBD	°C/W
θ_{JC}	Junction-to-case thermal resistance		QFP208	TBD	

38.1.1.2 Junction Temperature

The average chip-junction temperature, T_J , in °C can be obtained from the following:

- $T_J = T_A + (P_D \times \theta_{JA})$
- $T_J = T_A + (P_D \times (\theta_{HEATSINK} + \theta_{JC}))$

where:

- θ_{JA} = package thermal resistance, Junction-to-ambient (°C/W), provided in [Table 38-4 on page 769](#).
- θ_{JC} = package thermal resistance, Junction-to-case thermal resistance (°C/W), provided in [Table 38-4 on page 769](#).
- $\theta_{HEAT\ SINK}$ = cooling device thermal resistance (°C/W), provided in the device datasheet.
- P_D = device power consumption (W) estimated from data provided in the Power consumption section, in the next chapter.
- T_A = ambient temperature (°C).

From the first equation, the user can derive the estimated lifetime of the chip and decide if a cooling device is necessary or not. If a cooling device is to be fitted on the chip, the second equation should be used to compute the resulting average chip-junction temperature T_J in °C.

38.1.2 Package Drawings

Figure 38-1. 208-pin QFP Package Drawing

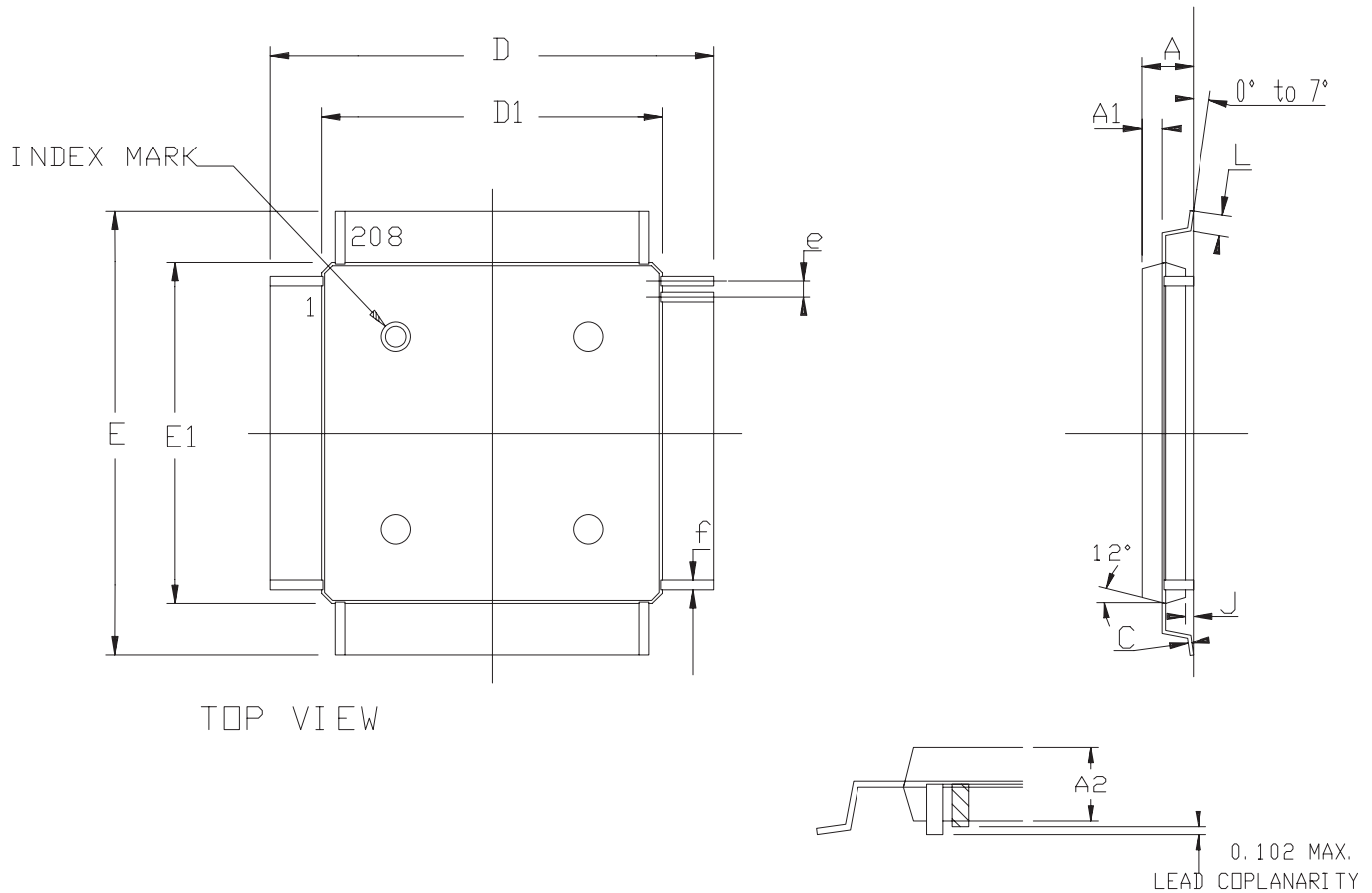

	MM		INCH	
	Min	Max	Min	Max
A	-	1.60	-	.063
C	0.09	0.20	.004	.008
A3	1.35	1.45	.053	.057
D	30.00 BSC		1.181 BSC	
D1	28.00 BSC		1.102 BSC	
E	30.00 BSC		1.181 BSC	
E1	28.00 BSC		1.102 BSC	
J	0.05	0.15	.002	.006
L	0.45	0.75	.018	.030
e	0.50 BSC		.0197 BSC	
f	0.22 BSC		.009 BSC	

Table 38-2. Soldering Information

Pin Land	TBD
Solder Mask Opening	TBD

Table 38-3. Device and 208-QFP Package Maximum Weight

TBD	mg
-----	----

Table 38-4. 208-QFP Package Characteristics

Moisture Sensitivity Level	TBD
----------------------------	-----

Table 38-5. Package Reference

JEDEC Drawing Reference	TBD
JESD97 Classification	TBD

38.1.3 Soldering Profile

Table 38-6 gives the recommended soldering profile from J-STD-20.

Table 38-6. Soldering Profile

Profile Feature	Green Package
Average Ramp-up Rate (217°C to Peak)	TBD
Preheat Temperature 175°C ±25°C	TBD
Temperature Maintained Above 217°C	TBD
Time within 5°C of Actual Peak Temperature	TBD
Peak Temperature Range	TBD
Ramp-down Rate	TBD
Time 25°C to Peak Temperature	TBD

Note: It is recommended to apply a soldering temperature higher than 250°C. A maximum of three reflow passes is allowed per component.

39. Electrical Characteristics

39.1 Absolute Maximum Ratings

Table 39-1. Absolute Maximum Ratings*

Operating Temperature (Industrial).....	-40°C to +85°C
Storage Temperature	-60°C to +150°C
Voltage on Input Pins with Respect to Ground-0.3V to VDDIO + 0.3V (+3.9V max)	
Maximum Operating Voltage (VDDCORE, VDDOSC, VDDPLL and VDDUSB)	1.95V
Maximum Operating Voltage (VDDIO)	3.6V
Total DC Output Current on all I/O lines	350 mA

*NOTICE: Stresses beyond those listed under “Absolute Maximum Ratings” may cause permanent damage to the device. This is a stress rating only and functional operation of the device at these or other conditions beyond those indicated in the operational sections of this specification is not implied. Exposure to absolute maximum rating conditions for extended periods may affect device reliability.

39.2 DC Characteristics

The following characteristics are applicable to the operating temperature range: $T_A = -40^{\circ}\text{C}$ to 85°C , unless otherwise specified and are certified for a junction temperature up to $T_J = 100^{\circ}\text{C}$.

Table 39-2. DC Characteristics

Symbol	Parameter	Conditions	Min	Typ	Max	Units
$V_{VDDCORE}$	DC Supply Core		1.65		1.95	V
V_{VDDBU}	DC Supply Backup		1.65		1.95	
V_{VDDOSC}	DC Supply Oscillator		1.65		1.95	V
V_{VDDPLL}	DC Supply PLL		1.65		1.95	V
V_{VDDUSB}	DC Supply USB		1.65		1.95	V
V_{VDDIO}	DC Supply Peripheral I/Os		3.0		3.6	V
V_{IL}	Input Low-level Voltage		-0.3		+0.8	V
V_{IH}	Input High-level Voltage		2.0		$V_{VDDIO}+0.3$	V
V_{OL}	Output Low-level Voltage	$I_{OL} = 8\text{ mA}$			0.4	V
V_{OH}	Output High-level Voltage	$I_{OH} = 8\text{ mA}$	$V_{VDDIO}-0.4$			V
I_{IL}	Input Leakage Current, Pin Low	Pullup resistors disabled			1	μA
I_{IH}	Input Leakage Current, Pin High	Pullup resistors disabled			1	μA
$R_{PULLUPPIO}$	Pull-up Resistance on PIO pins			190		kOhm
$R_{PULLUPCTRL}$	Pull-up Resistance on Control and JTAG pins			13		kOhm

Table 39-2. DC Characteristics (Continued)

I_o	Output Current				8	mA
I_{sc}	Static Current	On $V_{VDDCORE} = 1.8V$, CPU = 0 Hz All inputs driven; RESET_N=1	$T_A = 25^\circ C$		300	μA
			$T_A = 85^\circ C$		5000	

39.3 Power Consumption

- Typical power consumption of PLLs, Slow Clock and Main Oscillator.
- Power consumption of power supply in Active mode.
- Power consumption by peripheral: calculated as the difference in current measurement after having enabled then disabled the corresponding clock.

39.3.1 Power Consumption versus Modes

The values in [Table 39-3](#) and [Table 39-4 on page 772](#) are measured values of power consumption with operating conditions as follows:

- $V_{VDDIO} = 3.3V$
- $V_{VDDCORE} = V_{VDDUSB} = V_{VDDPLL} = V_{VDDOSC} = 1.8V$
- $T_A = 25^\circ C$
- There is no consumption on the I/Os of the device

Figure 39-1. Measures Schematics

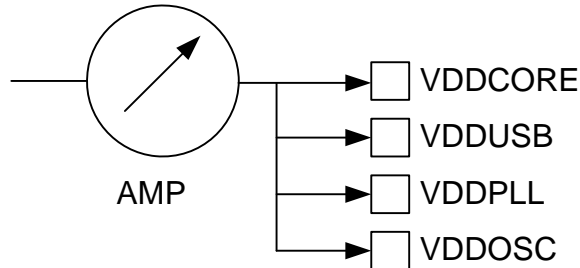

These figures represent the power consumption measured on the power supplies.

Table 39-3. Typical Power Consumption for Different Operating Modes

Mode	Conditions	Typical consumption	Unit
Active ⁽¹⁾	All peripheral clocks deactivated.	500	μA/MHz
Idle	All peripheral clocks activated.	480	
Frozen	All peripheral clocks activated.	280	
Standby	All peripheral clocks activated.	80	

Note: 1. The value is measured at best case condition. Actual current consumption will vary depending on the application.

Table 39-4. Power Consumption by Peripheral in Active Mode

Peripheral	Consumption	Unit
PIO Controller	3	μA/MHz ⁽¹⁾
USART	3	
USB	9	
MACB	31	
SMC	1	
SDRAMC	1	
AC97	5	
ISI	3	
Audio DAC	1	
LCDC	31	
TWI	1	
SPI	1	
MCI	7	
SSC	3	
Timer Counter Channels	1	

Note: 1. These numbers are relative to the actual CPU clock frequency, using the standard bus division: HSB and PBB divided by two. PBA divided by four.

39.4 Clock Characteristics

These parameters are given in the following conditions: $V_{VDDCORE} = 1.8V$, Ambient Temperature = 25°C, unless otherwise specified.

39.4.1 CPU Clock Characteristics

Table 39-5. Guaranteed CPU Clock Frequencies.

Symbol	Parameter	Conditions	Min	Max	Units
$1/(t_{CPUCPU})$	CPU Clock Frequency ⁽¹⁾	Temp = 85°C, $V_{VDDCORE} = 1.8V$		TBD	MHz
$1/(t_{CPUCPU})$	CPU Clock Frequency ⁽¹⁾	Temp = 85°C, $V_{VDDCORE} = 1.65V$		TBD	MHz

Note: 1. The bus clocks in the system should be divided, relative to the CPU, to be sure they operate in their specified range. The HSB and PBB bus clocks should be divided by two and the PBA bus clock should be divided by four relative to the CPU clock. The division factor of the buses can be set by programming the Power Manager register CKSEL.

Figure 39-2 and Figure 39-3 shows typical maximum CPU frequencies based on a selection of samples from different lots.

Figure 39-2. CPU Clock Frequency vs. $V_{VDDCORE}$ (Typical)

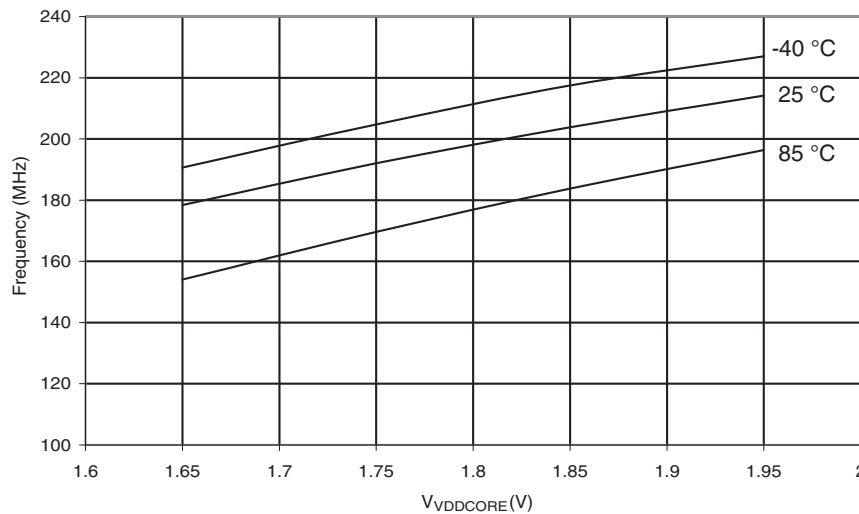
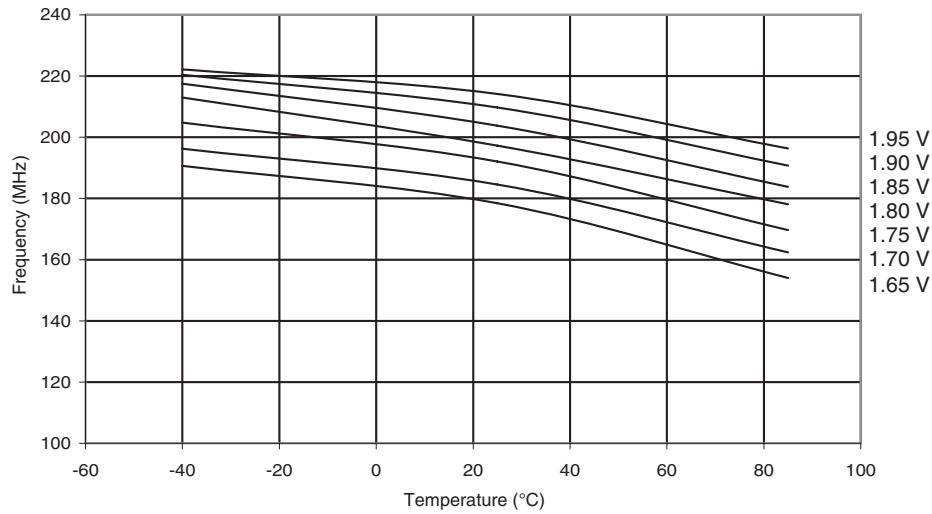

Figure 39-3. CPU Clock Frequency vs. Temperature (Typical)



39.4.2 XIN Clock Characteristics

Table 39-6. XIN Clock Electrical Characteristics

Symbol	Parameter	Conditions	Min	Max	Units
$1/(t_{CPXIN})$	XIN Clock Frequency ¹			50.0	MHz

Note: 1. These characteristics apply only when the Oscillators are in bypass mode (i.e., when OSCEN_N is 1)

39.4.3 RESET_N Characteristics

Table 39-7. RESET_N Electrical Characteristics

Symbol	Parameter	Conditions	Min	Max	Units
t_{RESET}	RESET_N minimum pulse length		50		ns

39.5 Crystal Oscillator Characteristics

The following characteristics are applicable to the operating temperature range: $T_A = -40^{\circ}\text{C}$ to 85°C and worst case of power supply, unless otherwise specified.

39.5.1 32 kHz Oscillator Characteristics

Table 39-8. 32 KHz Oscillator Characteristics

Symbol	Parameter	Conditions	Min	Typ	Max	Unit
$1/(t_{CP32KHz})$	Crystal Oscillator Frequency			32 768		Hz
t_{ST}	Startup Time	$V_{DDOSC} = 1.8\text{ V}$ $R_S = \text{TBD k}\Omega$, $C_L = \text{TBD pF}^{(1)}$		1000		ms

Note: 1. R_S is the equivalent series resistance, C_L is the equivalent load capacitance.

39.5.2 Main Oscillators Characteristics

Table 39-9. Main Oscillator Characteristics

Symbol	Parameter	Conditions	Min	Typ	Max	Unit
$1/(t_{CPMAIN})$	Crystal Oscillator Frequency		10		27	MHz
C_{L1}, C_{L2}	Internal Load Capacitance ($C_{L1} = C_{L2}$)			TBD		pF
t_{ST}	Startup Time			4		ms

Notes: 1. C_S is the shunt capacitance

39.5.3 PLL Characteristics

Table 39-10. Phase Lock Loop Characteristics

Symbol	Parameter	Conditions	Min	Typ	Max	Unit
F_{OUT}	Output Frequency	PLL:PLLOPT = 0b100	80		133	MHz
		PLL:PLLOPT = 0b110	TBD		TBD	MHz
F_{IN}	Input Frequency		TBD		TBD	MHz

Note: 1. Startup time depends on PLL RC filter. A calculation tool is provided by Atmel.

39.6 USB Transceiver Characteristics

39.6.1 Electrical Characteristics

Table 39-11. Electrical Parameters

Symbol	Parameter	Conditions	Min	Typ	Max	Unit
Input Levels						
V_{IL}	Low Level				TBD	V
V_{IH}	High Level		TBD			V
V_{DI}	Differential Input Sensivity	$ (D+) - (D-) $	TBD			V
V_{CM}	Differential Input Common Mode Range		TBD		TBD	V
C_{IN}	Transceiver capacitance	Capacitance to ground on each line			TBD	pF
I	Hi-Z State Data Line Leakage	$0V < V_{IN} < 3.3V$	TBD		TBD	μA
R_{EXT}	Recommended External USB Series Resistor	In series with each USB pin with $\pm 5\%$		TBD		Ω
Output Levels						
V_{OL}	Low Level Output	Measured with R_L of 1.425 k Ω tied to 3.6V	TBD		TBD	V
V_{OH}	High Level Output	Measured with R_L of 14.25 k Ω tied to GND	TBD		TBD	V
V_{CRS}	Output Signal Crossover Voltage	Measure conditions described in Figure 39-4	TBD		TBD	V

39.6.2 Switching Characteristics

Table 39-12. In Full Speed

Symbol	Parameter	Conditions	Min	Typ	Max	Unit
t_{FR}	Transition Rise Time	$C_{LOAD} = TBD$ pF	TBD		TBD	ns
t_{FE}	Transition Fall Time	$C_{LOAD} = TBD$ pF	TBD		TBD	ns
t_{FRFM}	Rise/Fall time Matching	$C_{LOAD} = TBD$ pF	TBD		TBD	%

Table 39-13. In High Speed

Symbol	Parameter	Conditions	Min	Typ	Max	Unit
t_{FR}	Transition Rise Time	$C_{LOAD} = TBD$ pF	TBD		TBD	ns
t_{FE}	Transition Fall Time	$C_{LOAD} = TBD$ pF	TBD		TBD	ns
t_{FRFM}	Rise/Fall time Matching		TBD		TBD	%

Figure 39-4. USB Data Signal Rise and Fall Times

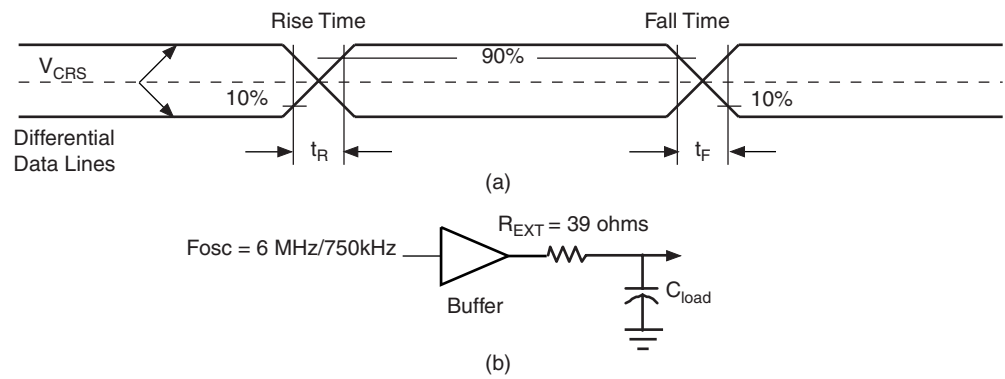

39.7 AC Characteristics - TBD

39.8 EBI Timings

These timings are given for worst case process, T = 85°C, VDDCORE = 1.65V, VDDIO = 3V and 50 pF load capacitance.

Table 39-14. SMC Read Signals with Hold Settings

Symbol	Parameter	Min	Units
NRD Controlled (READ_MODE = 1)			
SMC ₁	Data Setup before NRD High	-5.5	ns
SMC ₂	Data Hold after NRD High	-2.8	
SMC ₃	NRD High to NBS0/A0 Change ⁽¹⁾	nrd hold length * t _{CPMCK} - 1.3	
SMC ₄	NRD High to NBS1 Change ⁽¹⁾	nrd hold length * t _{CPMCK} - 1.3	
SMC ₅	NRD High to NBS2/A1 Change ⁽¹⁾	nrd hold length * t _{CPMCK} - 1.3	
SMC ₆	NRD High to NBS3 Change ⁽¹⁾	nrd hold length * t _{CPMCK} - 1.3	
SMC ₇	NRD High to A2 - A25 Change ⁽¹⁾	nrd hold length * t _{CPMCK} - 1.9	
SMC ₈	NRD High to NCS Inactive ⁽¹⁾	(nrd hold length - ncs rd hold length) * t _{CPMCK} - 1.0	
SMC ₉	NRD Pulse Width	nrd pulse length * t _{CPMCK} - 0.1	
NRD Controlled (READ_MODE = 0)			
SMC ₁₀	Data Setup before NCS High	-2.5	ns
SMC ₁₁	Data Hold after NCS High	-2.5	
SMC ₁₂	NCS High to NBS0/A0 Change ⁽¹⁾	ncs rd hold length * t _{CPMCK} - 5.6	
SMC ₁₃	NCS High to NBS0/A0 Change ⁽¹⁾	ncs rd hold length * t _{CPMCK} - 5.6	
SMC ₁₄	NCS High to NBS2/A1 Change ⁽¹⁾	ncs rd hold length * t _{CPMCK} - 5.6	
SMC ₁₅	NCS High to NBS3 Change ⁽¹⁾	ncs rd hold length * t _{CPMCK} - 5.6	
SMC ₁₆	NCS High to A2 - A25 Change ⁽¹⁾	ncs rd hold length * t _{CPMCK} - 0.1	
SMC ₁₇	NCS High to NRD Inactive ⁽¹⁾	ncs rd hold length - nrd hold length) * t _{CPMCK} - 4.3	
SMC ₁₈	NCS Pulse Width	ncs rd pulse length * t _{CPMCK} - 5.5	

Note: 1. hold length = total cycle duration - setup duration - pulse duration. "hold length" is for "ncs rd hold length" or "nrd hold length".

Table 39-15. SMC Read Signals with no Hold Settings

Symbol	Parameter	Min	Units
NRD Controlled (READ_MODE = 1)			
SMC ₁₉	Data Setup before NRD High	-3.3	ns
SMC ₂₀	Data Hold after NRD High	-2.9	
NRD Controlled (READ_MODE = 0)			
SMC ₂₁	Data Setup before NCS High	-2.8	ns
SMC ₂₂	Data Hold after NCS High	-2.6	

Table 39-16. SMC Write Signals with Hold Settings

Symbol	Parameter	Min	Units
NRD Controlled (READ_MODE = 1)			
SMC ₂₃	Data Out Valid before NWE High	$(nwe\ pulse\ length - 1) * t_{CPMCK} - 10.9$	ns
SMC ₂₄	Data Out Valid after NWE High ⁽¹⁾	$nwe\ hold\ length * t_{CPMCK} - 1.5$	
SMC ₂₅	NWE High to NBS0/A0 Change ⁽¹⁾	$nwe\ hold\ length * t_{CPMCK} - 1.0$	
SMC ₂₆	NWE High to NBS1 Change ⁽¹⁾	$nwe\ hold\ length * t_{CPMCK} - 1.0$	
SMC ₂₉	NWE High to NBS2/A1 Change ⁽¹⁾	$nwe\ hold\ length * t_{CPMCK} - TBD$	
SMC ₃₀	NWE High to NBS3 Change ⁽¹⁾	$nwe\ hold\ length * t_{CPMCK} - TBD$	
SMC ₃₁	NWE High to A2 - A25 Change ⁽¹⁾	$nwe\ hold\ length * t_{CPMCK} - 1.6$	
SMC ₃₂	NWE High to NCS Inactive ⁽¹⁾	$(nwe\ hold\ length - ncs\ wr\ hold\ length) * t_{CPMCK} - 0.7$	
SMC ₃₃	NWE Pulse Width	$nwe\ pulse\ length * t_{CPMCK}$	
NRD Controlled (READ_MODE = 0)			
SMC ₃₄	Data Out Valid before NCS High	$(ncs\ wr\ pulse\ length - 1) * t_{CPMCK} - 0.4$	ns
SMC ₃₅	Data Out Valid after NCS High ⁽¹⁾	$ncs\ wr\ hold\ length * t_{CPMCK} - 1.2$	
SMC ₃₆	NCS High to NWE Inactive ⁽¹⁾	$(ncs\ wr\ hold\ length - nwe\ hold\ length) * t_{CPMCK} - 4.9$	

Note: 1. hold length = total cycle duration - setup duration - pulse duration. "hold length" is for "ncs wr hold length" or "nwe hold length"

Table 39-17. SMC Write Signals with No Hold Settings (NWE Controlled only).

Symbol	Parameter	Min	Units
SMC ₃₇	NWE Rising to A2-A25 Valid	3.6	ns
SMC ₃₈	NWE Rising to NBS0/A0 Valid	3.7	
SMC ₃₉	NWE Rising to NBS1 Change	3.7	
SMC ₄₀	NWE Rising to A1/NBS2 Change	3.7	
SMC ₄₁	NWE Rising to NBS3 Change	3.7	
SMC ₄₂	NWE Rising to NCS Rising	3.8	
SMC ₄₃	Data Out Valid before NWE Rising	$(nwe\ pulse\ length - 1) * t_{CPMCK} - 4.9$	
SMC ₄₄	Data Out Valid after NWE Rising	3.8	
SMC ₄₅	NWE Pulse Width	$nwe\ pulse\ length * t_{CPMCK}$	

Figure 39-5. SMC Signals for NCS Controlled Accesses.

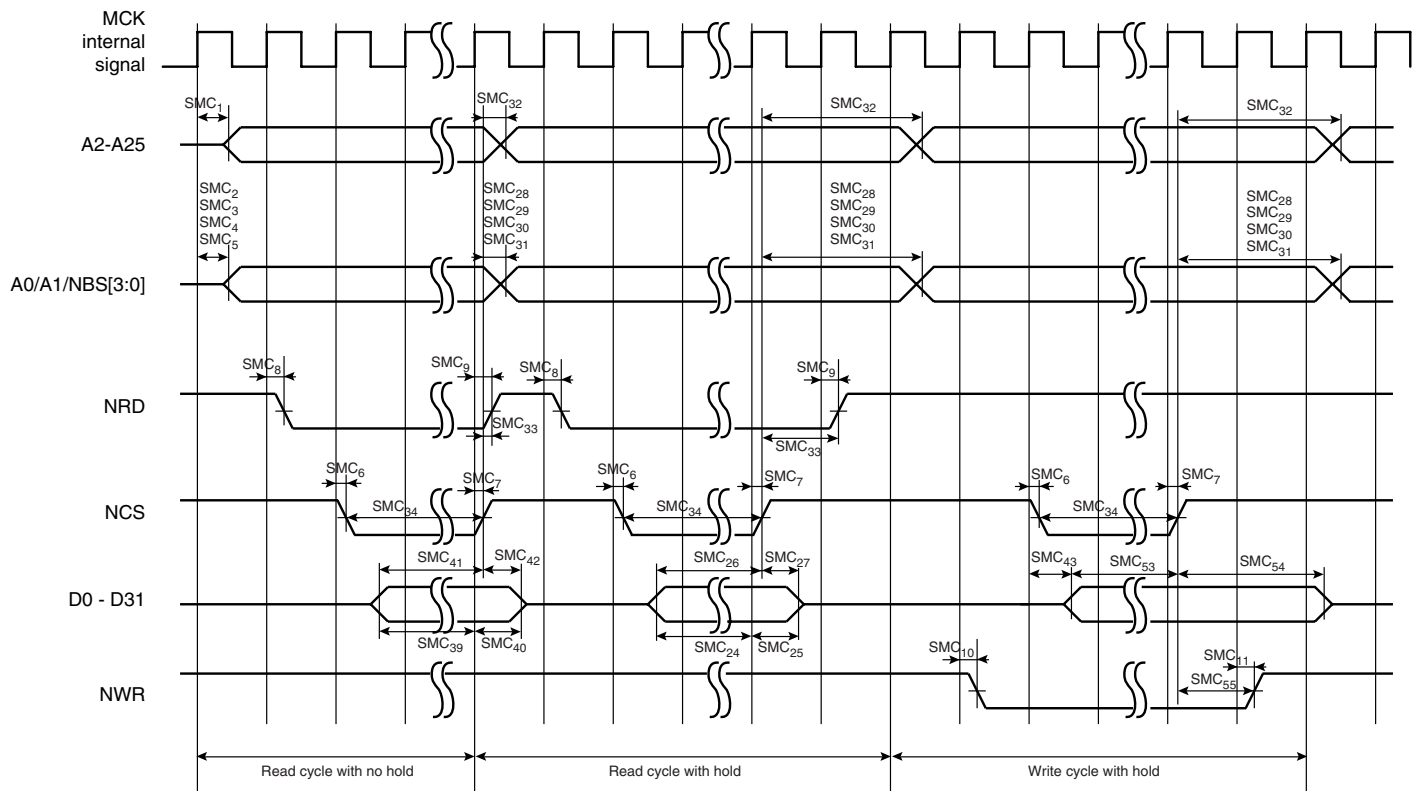
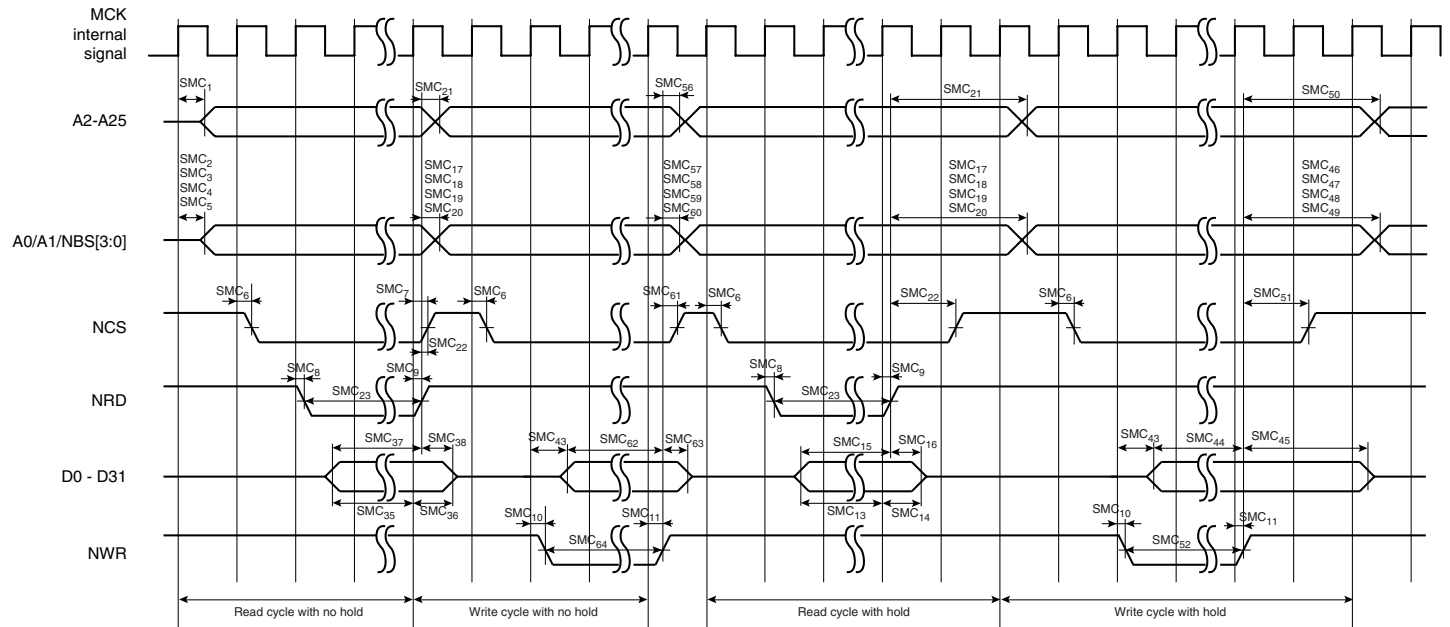

Figure 39-6. SMC Signals for NRD and NRW Controlled Accesses.



39.8.1 SDRAM Signals

These timings are given for 10 pF load on SDCK and 50 pF on other signals.

Table 39-18. SDRAM Clock Signal.

Symbol	Parameter	Max	Units
$1/(t_{\text{CPDCK}})$	SDRAM Controller Clock Frequency	TBD	MHz

Table 39-19. SDRAM Clock Signal.

Symbol	Parameter	Min	Units
SDRAMC ₁	SDCKE High before SDCK Rising Edge	6.8	ns
SDRAMC ₂	SDCKE Low after SDCK Rising Edge	5.8	
SDRAMC ₃	SDCKE Low before SDCK Rising Edge	6.8	
SDRAMC ₄	SDCKE High after SDCK Rising Edge	6.2	
SDRAMC ₅	SDCS Low before SDCK Rising Edge	6.7	
SDRAMC ₆	SDCS High after SDCK Rising Edge	5.9	
SDRAMC ₇	RAS Low before SDCK Rising Edge	6.7	
SDRAMC ₈	RAS High after SDCK Rising Edge	6.9	
SDRAMC ₉	SDA10 Change before SDCK Rising Edge	6.9	
SDRAMC ₁₀	SDA10 Change after SDCK Rising Edge	5.7	
SDRAMC ₁₁	Address Change before SDCK Rising Edge	6.4	
SDRAMC ₁₂	Address Change after SDCK Rising Edge	4.5	
SDRAMC ₁₃	Bank Change before SDCK Rising Edge	6.6	
SDRAMC ₁₄	Bank Change after SDCK Rising Edge	5.2	
SDRAMC ₁₅	CAS Low before SDCK Rising Edge	7.1	
SDRAMC ₁₆	CAS High after SDCK Rising Edge	5.9	
SDRAMC ₁₇	DQM Change before SDCK Rising Edge	6.5	
SDRAMC ₁₈	DQM Change after SDCK Rising Edge	4.6	
SDRAMC ₁₉	D0-D15 in Setup before SDCK Rising Edge	2.3	
SDRAMC ₂₀	D0-D15 in Hold after SDCK Rising Edge	3.9	
SDRAMC ₂₁	D16-D31 in Setup before SDCK Rising Edge	0.9	
SDRAMC ₂₂	D16-D31 in Hold after SDCK Rising Edge	4.0	
SDRAMC ₂₃	SDWE Low before SDCK Rising Edge	6.5	
SDRAMC ₂₄	SDWE High after SDCK Rising Edge	7.0	
SDRAMC ₂₅	D0-D15 Out Valid before SDCK Rising Edge	6.2	
SDRAMC ₂₆	D0-D15 Out Valid after SDCK Rising Edge	4.1	
SDRAMC ₂₇	D16-D31 Out Valid before SDCK Rising Edge	6.2	
SDRAMC ₂₈	D16-D31 Out Valid after SDCK Rising Edge	4.5	

Figure 39-7. SDRAMC Signals relative to SDCK.

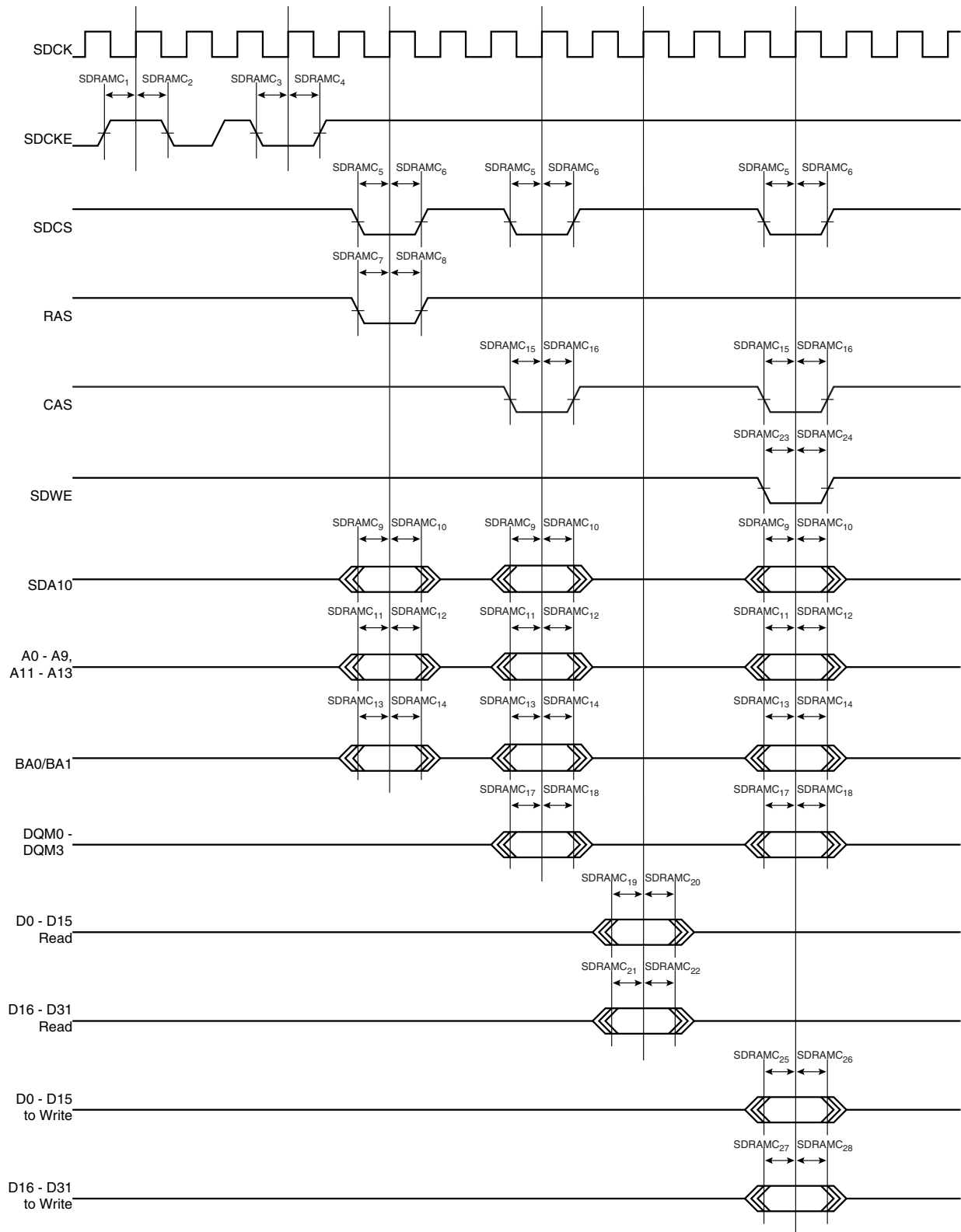

40. Ordering Information

Figure 40-1. Ordering Information

Ordering Code	Package	Package Type	Packing	Temperature Operating Range
AT32AP7001-ALUT	QFP208	Green	Tray	Industrial (-40°C to 85°C)

41. Errata

41.1 Rev. C

1. SPI FDIV option does not work

Selecting clock signal using FDIV = 1 does not work as specified.

Fix/Workaround

Do not set FDIV = 1.

2. SPI Chip Select 0 BITS field overrides other Chip Selects

The BITS field for Chip Select 0 overrides BITS fields for other Chip selects.

Fix/Workaround

Update Chip Select 0 BITS field to the relevant settings before transmitting with Chip Selects other than 0.

3. SPI LASTXFER may be overwritten

When Peripheral Select (PS) = 0, the LASTXFER-bit in the Transmit Data Register (TDR) should be internally discarded. This fails and may cause problems during DMA transfers. Transmitting data using the PDC when PS=0, the size of the transferred data is 8- or 16-bits. The upper 16 bits of the TDR will be written to a random value. If Chip Select Active After Transfer (CSAAT) = 1, the behavior of the Chip Select will be unpredictable.

Fix/Workaround

- Do not use CSAAT = 1 if PS = 0
- Use GPIO to control Chip Select lines
- Select PS=1 and store data for PCS and LASTXFER for each data in transmit buffer.

4. SPI LASTXFER overrides Chip Select

The LASTXFER bit overrides Chip Select input when PS = 0 and CSAAT is used.

Fix/Workaround

- Do not use the CSAAT
- Use GPIO as Chip Select input
- Select PS = 1. Transfer 32-bit with correct LASTXFER settings.

5. MMC data write operation with less than 12 bytes is impossible.

The Data Write operation with a number of bytes less than 12 is impossible

Fix/Workaround

The PDC counters must always be equal to 12 bytes for data transfers lower than 12 bytes. The BLKLEN or BCNT field are used to specify the real count number.

6. MMC SDIO interrupt only works for slot A

If 1-bit data bus width and on other slots than slot A, the SDIO interrupt can not be captured.

Fix/Workaround

Use slot A.

7. PSIF TXEN/RXEN may disable the transmitter/receiver

Writing a '0' to RXEN will disable the receiver. Writing '0' to TXEN will disable the transmitter.

Fix/Workaround

When accessing the PS/2 Control Register always write '1' to RXEN to keep the receiver enabled, and write '1' to TXEN to keep the transmitter enabled.

8. PSIF TXRDY interrupt corrupts transfers

When writing to the Transmit Holding Register (THR), the data will be transferred to the data shift register immediately, regardless of the state of the data shift register. If a transfer is ongoing, it will be interrupted and a new transfer will be started with the new data written to THR.

Fix/Workaround

Use the TXEMPTY-interrupt instead of the TXRDY-interrupt to update the THR. This ensures that a transfer is completed.

9. PWN counter restarts at 0x0001

The PWN counter restarts at 0x0001 and not 0x0000 as specified. Because of this the first PWM period has one more clock cycle.

Fix/Workaround

- The first period is 0x0000, 0x0001, ..., period
- Consecutive periods are 0x0001, 0x0002, ..., period

10. PWM channel interrupt enabling triggers an interrupt

When enabling a PWM channel that is configured with center aligned period (CALG=1), an interrupt is signalled.

Fix/Workaround

When using center aligned mode, enable the channel and read the status before channel interrupt is enabled.

11. PWM update period to a 0 value does not work

It is impossible to update a period equal to 0 by the using the PWM update register (PWM_CUPD).

Fix/Workaround

Do not update the PWM_CUPD register with a value equal to 0.

12. PWM channel status may be wrong if disabled before a period has elapsed

Before a PWM period has elapsed, the read channel status may be wrong. The CHIDx-bit for a PWM channel in the PWM Enable Register will read '1' for one full PWM period even if the channel was disabled before the period elapsed. It will then read '0' as expected.

Fix/Workaround

Reading the PWM channel status of a disabled channel is only correct after a PWM period

13. TWI transfer error without ACK

If the TWI does not receive an ACK from a slave during the address+R/W phase, no bits in the status register will be set to indicate this. Hence, the transfer will never complete.

Fix/Workaround

To prevent errors due to missing ACK, the software should use a timeout mechanism to terminate the transfer if this happens.

41.2 Rev. B

Not sampled.

41.3 Rev. A

Not sampled.

42. Datasheet Revision History

Please note that the referring page numbers in this section are referred to this document. The referring revision in this section are referring to the document revision.

42.1 Rev. A 02/07

1. Initial revision.

Table of Contents

	Features	1
1	Part Description	2
2	Signals Description	4
3	Power Considerations	10
	3.1 Power Supplies	10
	3.2 Power Supply Connections	10
4	Package and Pinout	12
5	Blockdiagram	14
	5.1 Processor and architecture	15
6	I/O Line Considerations	19
	6.1 JTAG pins	19
	6.2 WAKE_N pin	19
	6.3 RESET_N pin	19
	6.4 EVTI_N pin	19
	6.5 TWI pins	19
	6.6 PIO pins	19
7	Peripherals	21
	7.1 Peripheral address map	21
	7.2 Interrupt Request Signal Map	23
	7.3 DMAC Handshake Interface Map	25
	7.4 Clock Connections	26
	7.5 External Interrupt Pin Mapping	27
	7.6 Nexus OCD AUX port connections	27
	7.7 Peripheral Multiplexing on IO lines	28
	7.8 Peripheral overview	36
8	Memories	43
	8.1 Embedded Memories	43
	8.2 Physical Memory Map	43
9	Power Manager	46
	9.1 Features	46
	9.2 Description	46

9.3 Block Diagram	47
9.4 Product Dependencies	48
9.5 Functional Description	48
9.6 User Interface	59
10 Real Time Counter	67
10.1 Features	67
10.2 Description	67
10.3 Block Diagram	68
10.4 Product Dependencies	68
10.5 Functional Description	69
10.6 User Interface	70
11 External Interrupts	78
11.1 Features	78
11.2 Description	78
11.3 Block Diagram	78
11.4 Product Dependencies	78
11.5 Functional Description	79
11.6 User Interface	80
12 Boot Sequence	85
12.1 Starting of clocks	85
12.2 Fetching of initial instructions	85
13 Mechanical Characteristics - TBD	86
13.1 Thermal Considerations	86
13.2 Package Drawings	87
13.3 Soldering Profile	88
14 Electrical Characteristics - TBD	89
14.1 Absolute Maximum Ratings	89
14.2 DC Characteristics	89
14.3 Power Consumption	90
14.4 Clock Characteristics	92
14.5 Crystal Oscillator Characteristics	93
14.6 USB Transceiver Characteristics	94
14.7 AC Characteristics - TBD	96
14.8 EBI Timings - TBD	96

15 Ordering Information 97

16 Revision History 98

 16.1 Rev. F 07/0698

 16.2 Rev. E 05/0698

 16.3 Rev. D 04/0698

 16.4 Rev. C 04/0698

Table of Contents..... i





Atmel Corporation

2325 Orchard Parkway
San Jose, CA 95131, USA
Tel: 1(408) 441-0311
Fax: 1(408) 487-2600

Regional Headquarters

Europe

Atmel Sarl
Route des Arsenalux 41
Case Postale 80
CH-1705 Fribourg
Switzerland
Tel: (41) 26-426-5555
Fax: (41) 26-426-5500

Asia

Room 1219
Chinachem Golden Plaza
77 Mody Road Tsimshatsui
East Kowloon
Hong Kong
Tel: (852) 2721-9778
Fax: (852) 2722-1369

Japan

9F, Tonetsu Shinkawa Bldg.
1-24-8 Shinkawa
Chuo-ku, Tokyo 104-0033
Japan
Tel: (81) 3-3523-3551
Fax: (81) 3-3523-7581

Atmel Operations

Memory

2325 Orchard Parkway
San Jose, CA 95131, USA
Tel: 1(408) 441-0311
Fax: 1(408) 436-4314

Microcontrollers

2325 Orchard Parkway
San Jose, CA 95131, USA
Tel: 1(408) 441-0311
Fax: 1(408) 436-4314

La Chantrerie
BP 70602
44306 Nantes Cedex 3, France
Tel: (33) 2-40-18-18-18
Fax: (33) 2-40-18-19-60

ASIC/ASSP/Smart Cards

Zone Industrielle
13106 Rousset Cedex, France
Tel: (33) 4-42-53-60-00
Fax: (33) 4-42-53-60-01

1150 East Cheyenne Mtn. Blvd.
Colorado Springs, CO 80906, USA
Tel: 1(719) 576-3300
Fax: 1(719) 540-1759

Scottish Enterprise Technology Park
Maxwell Building
East Kilbride G75 0QR, Scotland
Tel: (44) 1355-803-000
Fax: (44) 1355-242-743

RF/Automotive

Theresienstrasse 2
Postfach 3535
74025 Heilbronn, Germany
Tel: (49) 71-31-67-0
Fax: (49) 71-31-67-2340

1150 East Cheyenne Mtn. Blvd.
Colorado Springs, CO 80906, USA
Tel: 1(719) 576-3300
Fax: 1(719) 540-1759

Biometrics/Imaging/Hi-Rel MPU/ High Speed Converters/RF Datacom

Avenue de Rochepleine
BP 123
38521 Saint-Egreve Cedex, France
Tel: (33) 4-76-58-30-00
Fax: (33) 4-76-58-34-80

Literature Requests

www.atmel.com/literature

Disclaimer: The information in this document is provided in connection with Atmel products. No license, express or implied, by estoppel or otherwise, to any intellectual property right is granted by this document or in connection with the sale of Atmel products. **EXCEPT AS SET FORTH IN ATMEL'S TERMS AND CONDITIONS OF SALE LOCATED ON ATMEL'S WEB SITE, ATMEL ASSUMES NO LIABILITY WHATSOEVER AND DISCLAIMS ANY EXPRESS, IMPLIED OR STATUTORY WARRANTY RELATING TO ITS PRODUCTS INCLUDING, BUT NOT LIMITED TO, THE IMPLIED WARRANTY OF MERCHANTABILITY, FITNESS FOR A PARTICULAR PURPOSE, OR NON-INFRINGEMENT. IN NO EVENT SHALL ATMEL BE LIABLE FOR ANY DIRECT, INDIRECT, CONSEQUENTIAL, PUNITIVE, SPECIAL OR INCIDENTAL DAMAGES (INCLUDING, WITHOUT LIMITATION, DAMAGES FOR LOSS OF PROFITS, BUSINESS INTERRUPTION, OR LOSS OF INFORMATION) ARISING OUT OF THE USE OR INABILITY TO USE THIS DOCUMENT, EVEN IF ATMEL HAS BEEN ADVISED OF THE POSSIBILITY OF SUCH DAMAGES.** Atmel makes no representations or warranties with respect to the accuracy or completeness of the contents of this document and reserves the right to make changes to specifications and product descriptions at any time without notice. Atmel does not make any commitment to update the information contained herein. Unless specifically provided otherwise, Atmel products are not suitable for, and shall not be used in, automotive applications. Atmel's products are not intended, authorized, or warranted for use as components in applications intended to support or sustain life.

© 2007 Atmel Corporation. All rights reserved. ATMEL®, logo and combinations thereof, Everywhere You Are®, AVR®, and others, are registered trademarks or trademarks of Atmel Corporation or its subsidiaries. Other terms and product names may be trademarks of others.