

4-BIT SINGLE-CHIP MICROCONTROLLER**DESCRIPTION**

The μ PD753108 is one of the 75XL Series 4-bit single-chip microcontroller chips and has a data processing capability comparable to that of an 8-bit microcontroller.

The existing 75X Series containing an LCD controller/driver supplies an 80-pin package.

The μ PD753108 supplies a 64-pin package (12 × 12), which is suitable for small-scale systems.

It features expanded CPU functions and can provide high-speed operation at a low supply voltage of 1.8 V compared with the existing μ PD75308B.

Detailed function descriptions are provided in the following user's manual. Be sure to read it before designing.

μ PD753108 User's Manual: U10890E

FEATURES

- Low voltage operation: $V_{DD} = 1.8$ to 5.5 V
 - Can be driven by two 1.5 V batteries
- Internal memory
- Program memory (ROM):
 - 4096 × 8 bits (μ PD753104)
 - 6144 × 8 bits (μ PD753106)
 - 8192 × 8 bits (μ PD753108)
- Data memory (RAM):
 - 512 × 4 bits
- Capable of high-speed operation and variable instruction execution time for power saving
 - 0.95, 1.91, 3.81, 15.3 μ s (@ 4.19 MHz with main system clock)
 - 0.67, 1.33, 2.67, 10.7 μ s (@ 6.0 MHz with main system clock)
 - 122 μ s (@ 32.768 kHz with subsystem clock)
- Internal programmable LCD controller/driver
- Small package:
 - 64-pin plastic LQFP (12 × 12), 64-pin plastic TQFP (12 × 12)
- One-time PROM version: μ PD75P3116

APPLICATION

Remote controllers, cameras, hemodynamometers, electronic scale, gas meters, etc.

Unless otherwise indicated, references in this data sheet to the μ PD753108 mean the μ PD753104 and μ PD753106.

The information in this document is subject to change without notice. Before using this document, please confirm that this is the latest version.

Not all devices/types available in every country. Please check with local NEC representative for availability and additional information.

ORDERING INFORMATION

	Part number	Package	
	μ PD753104GC-xxx-AB8	64-pin plastic QFP	(14 × 14)
	μ PD753104GK-xxx-8A8	64-pin plastic LQFP	(12 × 12)
★	μ PD753104GK-xxx-9ET	64-pin plastic TQFP	(12 × 12)
	μ PD753106GC-xxx-AB8	64-pin plastic QFP	(14 × 14)
	μ PD753106GK-xxx-8A8	64-pin plastic LQFP	(12 × 12)
★	μ PD753106GK-xxx-9ET	64-pin plastic TQFP	(12 × 12)
	μ PD753108GC-xxx-AB8	64-pin plastic QFP	(14 × 14)
	μ PD753108GK-xxx-8A8	64-pin plastic LQFP	(12 × 12)
★	μ PD753108GK-xxx-9ET	64-pin plastic TQFP	(12 × 12)

Remark xxx indicates ROM code suffix.

OVERVIEW OF FUNCTIONS

Parameter		Function	
Instruction execution time		<ul style="list-style-type: none"> • 0.95, 1.91, 3.81, 15.3 μs (@ 4.19 MHz with main system clock) • 0.67, 1.33, 2.67, 10.7 μs (@ 6.0 MHz with main system clock) • 122 μs (@ 32.768 kHz with subsystem clock) 	
Internal memory	ROM	4096 × 8 bits (μPD753104), 6144 × 8 bits (μPD753106), 8192 × 8 bits (μPD753108)	
	RAM	512 × 4 bits	
General-purpose register		<ul style="list-style-type: none"> • 4-bit operation: 8 × 4 banks • 8-bit operation: 4 × 4 banks 	
I/O port	CMOS input	8	On-chip pull-up resistors which can be specified by means of software: 7
	CMOS I/O	20	On-chip pull-up resistors which can be specified by means of software: 12 Also used for segment pins: 8
	N-ch open-drain I/O pins	4	On-chip pull-up resistors which can be specified by mask option, 13 V withstand voltage
	Total	32	
LCD controller/driver		<ul style="list-style-type: none"> • Segment selection: 16/20/24 segments (can be changed to CMOS I/O port in 4 time-unit; max. 8) • Display mode selection: Static, 1/2 duty (1/2 bias), 1/3 duty (1/2 bias), 1/3 duty (1/3 bias), 1/4 duty (1/3 bias) • On-chip split resistor for LCD drive can be specified by mask option 	
Timer		5 channels <ul style="list-style-type: none"> • 8-bit timer/event counter: 3 channels (16-bit timer/event counter, carrier generator, timer with gate) • Basic interval timer/watchdog timer: 1 channel • Watch timer: 1 channel 	
Serial interface		<ul style="list-style-type: none"> • 3-wire serial I/O mode ... MSB or LSB can be selected for transferring first bit • 2-wire serial I/O mode • SBI mode 	
Bit sequential buffer (BSB)		16 bits	
Clock output (PCL)		<ul style="list-style-type: none"> • Φ, 524, 262, 65.5 kHz (@ 4.19 MHz with main system clock) • Φ, 750, 375, 93.8 kHz (@ 6.0 MHz with main system clock) 	
Buzzer output (BUZ)		<ul style="list-style-type: none"> • 2, 4, 32 kHz (@ 4.19 MHz with main system clock or @ 32.768 kHz with subsystem clock) • 2.93, 5.86, 46.9 kHz (@ 6.0 MHz with main system clock) 	
Vectored interrupt		External: 3, Internal: 5	
Test input		External: 1, Internal: 1	
System clock oscillator		<ul style="list-style-type: none"> • Ceramic or crystal oscillator for main system clock oscillation • Crystal oscillator for subsystem clock oscillation 	
Standby function		STOP/HALT mode	
Supply voltage		V _{DD} = 1.8 to 5.5 V	
Package		<ul style="list-style-type: none"> • 64-pin plastic QFP (14 × 14) • 64-pin plastic LQFP (12 × 12) • 64-pin plastic TQFP (12 × 12) 	

★

CONTENTS

- 1. PIN CONFIGURATION (TOP VIEW) 6
- 2. BLOCK DIAGRAM 8
- 3. PIN FUNCTIONS 9
 - 3.1 Port Pins 9
 - 3.2 Non-Port Pins 11
 - 3.3 Pin I/O Circuits 13
 - 3.4 Recommended Connections of Unused Pins 15
- 4. SWITCHING FUNCTION BETWEEN Mk I MODE AND Mk II MODE 16
 - 4.1 Difference Between Mk I Mode and Mk II Mode 16
 - 4.2 Setting Method of Stack Bank Select Register (SBS) 17
- 5. MEMORY CONFIGURATION 18
- 6. PERIPHERAL HARDWARE FUNCTION 23
 - 6.1 Digital I/O Port 23
 - 6.2 Clock Generator 23
 - 6.3 Subsystem Clock Oscillator Control Functions 25
 - 6.4 Clock Output Circuit 26
 - 6.5 Basic Interval Timer/Watchdog Timer 27
 - 6.6 Watch Timer 28
 - 6.7 Timer/Event Counter 29
 - 6.8 Serial Interface 33
 - 6.9 LCD Controller/Driver 35
 - 6.10 Bit Sequential Buffer 37
- 7. INTERRUPT FUNCTION AND TEST FUNCTION 38
- 8. STANDBY FUNCTION 40
- 9. RESET FUNCTION 41
- 10. MASK OPTION 44
- 11. INSTRUCTION SET 45
- 12. ELECTRICAL SPECIFICATIONS 59
- 13. CHARACTERISTIC CURVES (FOR REFERENCE ONLY) 75
- 14. PACKAGE DRAWINGS 78
- 15. RECOMMENDED SOLDERING CONDITIONS 81

APPENDIX A. μPD75308B, 753108 AND 75P3116 FUNCTIONAL LIST 83

APPENDIX B. DEVELOPMENT TOOLS 85

APPENDIX C. RELATED DOCUMENTS 89

1. PIN CONFIGURATION (TOP VIEW)

- 64-pin plastic QFP (14 × 14)
μPD753104GC-xxx-AB8, 753106GC-xxx-AB8, 753108GC-xxx-AB8
- 64-pin plastic LQFP (12 × 12)
μPD753104GK-xxx-8A8, 753106GK-xxx-8A8, 753108GK-xxx-8A8
- ★ • 64-pin plastic TQFP (12 × 12)
μPD753104GK-xxx-9ET, 753106GK-xxx-9ET, 753108GK-xxx-9ET

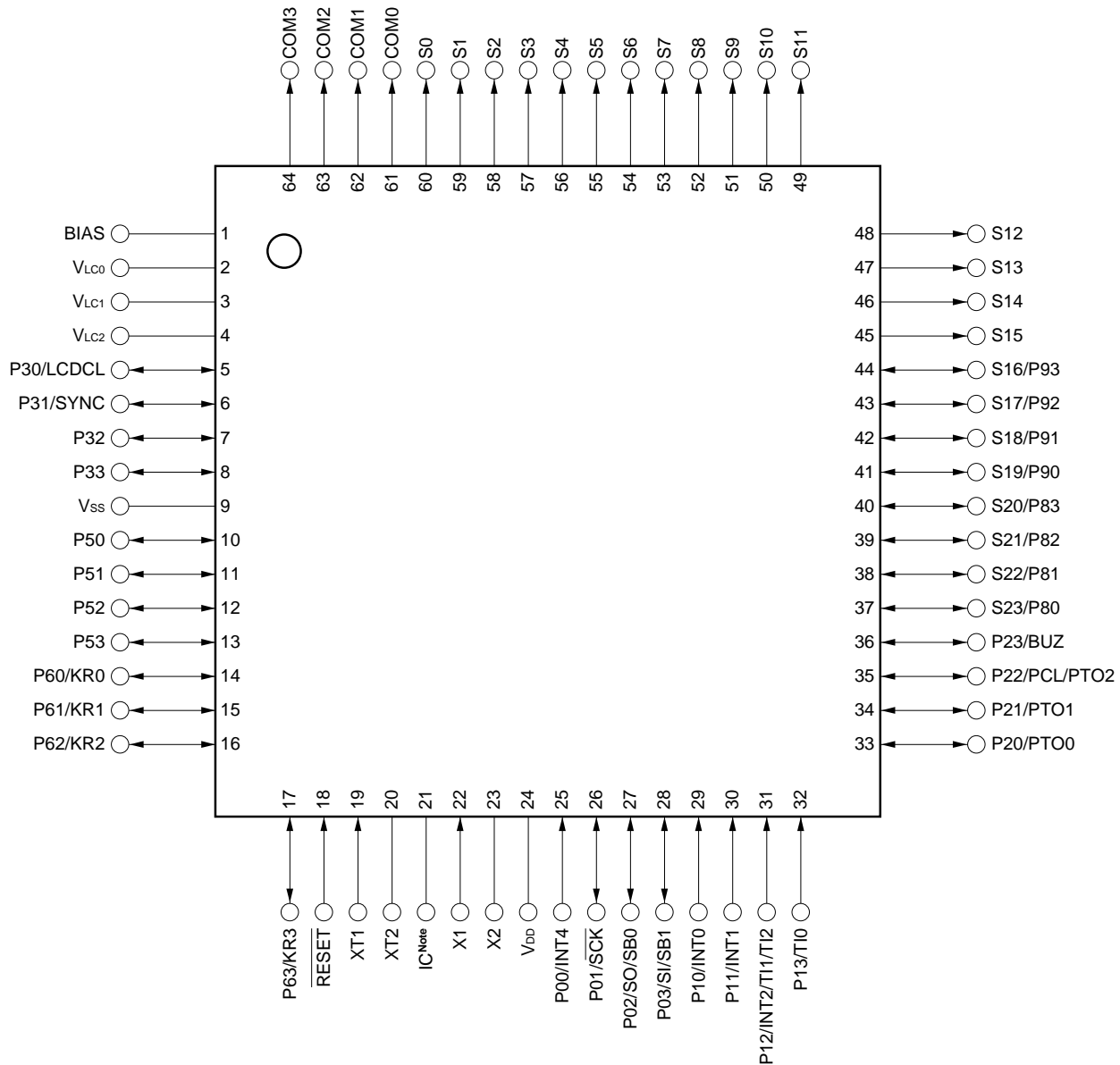

Note Connect the IC (Internally Connected) pin directly to V_{DD}.

Pin Identification

P00 to P03:	Port 0	V _{LC0} to V _{LC2} :	LCD Power Supply 0 to 2
P10 to P13:	Port 1	BIAS:	LCD Power Supply Bias Control
P20 to P23:	Port 2	LCDCL:	LCD Clock
P30 to P33:	Port 3	SYNC:	LCD Synchronization
P50 to P53:	Port 5	TI0 to TI2:	Timer Input 0 to 2
P60 to P63:	Port 6	PTO0 to PTO2:	Programmable Timer Output 0 to 2
P80 to P83:	Port 8	BUZ:	Buzzer Clock
P90 to P93:	Port 9	PCL:	Programmable Clock
KR0 to KR3:	Key Return 0 to 3	INT0, INT1, INT4:	External Vectored Interrupt 0, 1, 4
\overline{SCK} :	Serial Clock	INT2:	External Test Input 2
SI:	Serial Input	X1, X2:	Main System Clock Oscillation 1, 2
SO:	Serial Output	XT1, XT2:	Subsystem Clock Oscillation 1, 2
SB0, SB1:	Serial Data Bus 0, 1	V _{DD} :	Positive Power Supply
\overline{RESET} :	Reset	V _{SS} :	Ground
S0 to S23:	Segment Output 0 to 23	IC:	Internally Connected
COM0 to COM3:	Common Output 0 to 3		

2. BLOCK DIAGRAM

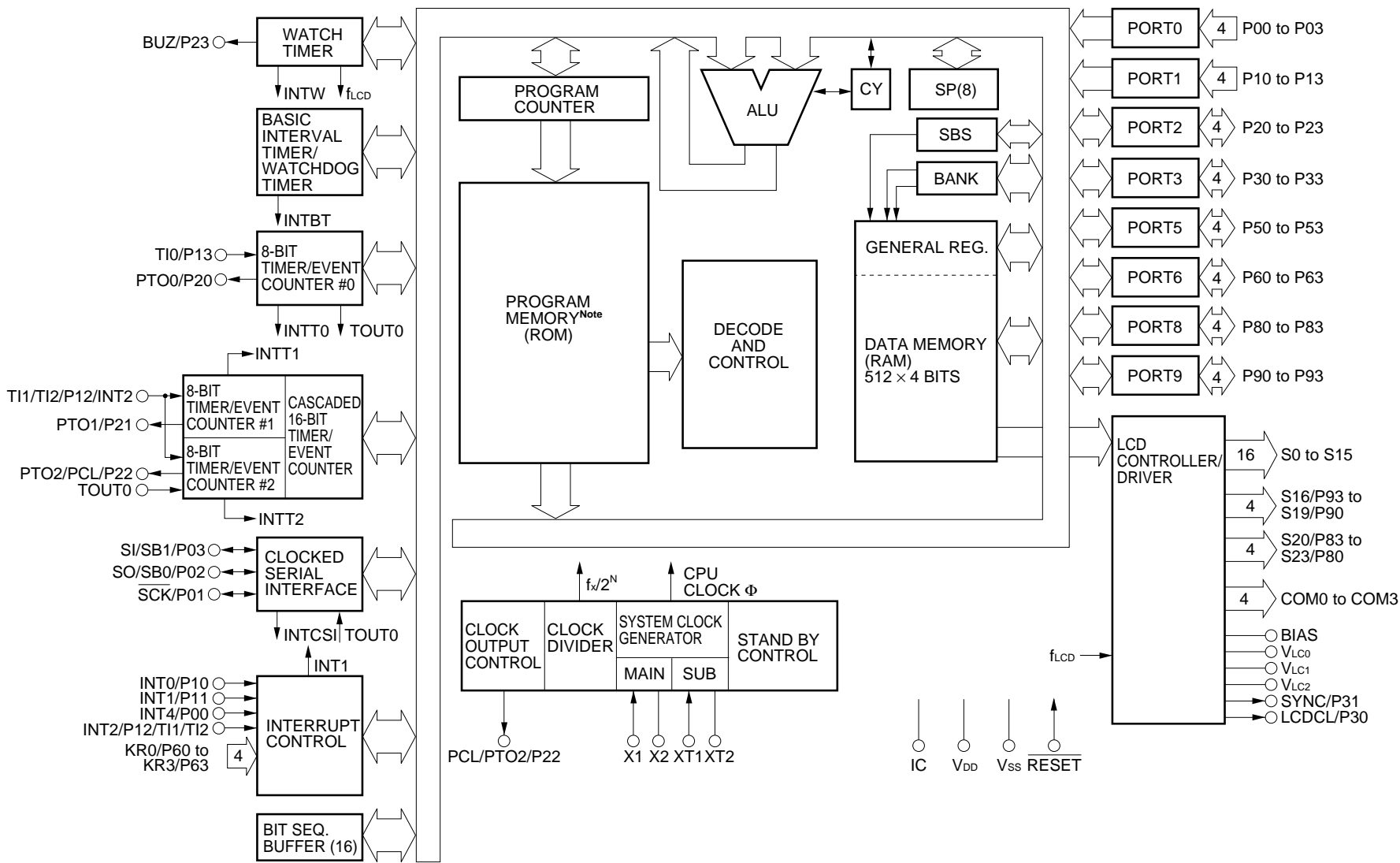

Note The ROM capacity depends on the product.

3. PIN FUNCTIONS

3.1 Port Pins (1/2)

Pin Name	I/O	Alternate Function	Function	8-bit I/O	After Reset	I/O Circuit TYPE ^{Note 1}
P00	Input	INT4	4-bit input port (PORT0). An on-chip pull-up resistor can be specified by means of software in 3-bit units.	No	Input	(B)
P01		$\overline{\text{SCK}}$				(F)-A
P02		SO/SB0				(F)-B
P03		SI/SB1				(M)-C
P10	Input	INT0	4-bit input port (PORT1). An on-chip pull-up resistor can be specified by means of software in 4-bit units. P10/INT0 can select noise elimination circuit.	No	Input	(B)-C
P11		INT1				
P12		T11/T12/INT2				
P13		T10				
P20	I/O	PTO0	4-bit I/O port (PORT2). An on-chip pull-up resistor can be specified by means of software in 4-bit units.	No	Input	E-B
P21		PTO1				
P22		PCL/PTO2				
P23		BUZ				
P30	I/O	LCDCL	Programmable 4-bit I/O port (PORT3). Input/output can be specified in 1-bit units. An on-chip pull-up resistor can be specified by means of software in 4-bit units.	No	Input	E-B
P31		SYNC				
P32		–				
P33		–				
P50 to P53 ^{Note 2}	I/O	–	N-ch open-drain 4-bit I/O port (PORT5). An on-chip pull-up resistor can be specified in 1-bit units (mask option). Withstand voltage is 13 V in open-drain mode.	No	High level (when pull-up resistors are provided) or high-impedance	M-D

Notes 1. Characters in parentheses indicate the Schmitt-triggered input.

- If on-chip pull-up resistors are not specified by mask option (when used as N-ch open-drain input port), low-level input leakage current increases when input or bit manipulation instruction is executed.

3.1 Port Pins (2/2)

Pin Name	I/O	Alternate Function	Function	8-bit I/O	After Reset	I/O Circuit TYPE ^{Note 1}
P60	I/O	KR0	Programmable 4-bit I/O port (PORT6). Input/output can be specified in 1-bit units. An on-chip pull-up resistor can be specified by means of software in 4-bit units.	No	Input	(F)-A
P61		KR1				
P62		KR2				
P63		KR3				
P80	I/O	S23	4-bit I/O port (PORT8). An on-chip pull-up resistor can be specified by means of software in 4-bit units ^{Note 2} .	Yes	Input	H
P81		S22				
P82		S21				
P83		S20				
P90	I/O	S19	4-bit I/O port (PORT9). An on-chip pull-up resistor can be specified by means of software in 4-bit units ^{Note 2} .		Input	H
P91		S18				
P92		S17				
P93		S16				

Notes 1. Characters in parentheses indicate the Schmitt-triggered input.

2. When these pins are used as segment signal output pins, do not connect the on-chip pull-up resistor by means of software.

3.2 Non-Port Pins (1/2)

Pin Name	I/O	Alternate Function	Function	After Reset	I/O Circuit TYPE ^{Note 1}
T10	Input	P13	External event pulse input to the timer/event counter.	Input	(B)-C
T11		P12/INT2/TI2			
T12		P12/INT2/TI1			
PTO0	Output	P20	Timer/event counter output	Input	E-B
PTO1		P21			
PTO2		P22/PCL			
PCL		P22/PTO2	Clock output		
BUZ		P23	Optional frequency output (for buzzer output or system clock trimming)		
\overline{SCK}	I/O	P01	Serial clock I/O	Input	(F)-A
SO/SB0		P02	Serial data output Serial data bus I/O		(F)-B
SI/SB1		P03	Serial data input Serial data bus I/O		(M)-C
INT4	Input	P00	Edge detection vectored interrupt input (both rising edge and falling edge detection)	Input	(B)
INT0	Input	P10	Edge detection vectored interrupt input (detection edge can be selected). INT0/P10 can select noise elimination circuit.	Input	(B)-C
INT1		P11			
INT2		P12/TI1/TI2	Rising edge detection testable input Asynchronous		
KR0 to KR3	Input	P60 to P63	Falling edge detection testable input	Input	(F)-A
S0 to S15	Output	–	Segment signal output	Note 2	G-A
S16 to S19	Output	P93 to P90	Segment signal output	Input	H
S20 to S23	Output	P83 to P80	Segment signal output	Input	H
COM0 to COM3	Output	–	Common signal output	Note 2	G-B
V _{LC0} to V _{LC2}	–	–	LCD drive power On-chip split resistor is enabled (mask option).	–	–
BIAS	Output	–	Output for external split resistor disconnect	Note 3	–
LCDCL ^{Note 4}	Output	P30	Clock output for externally expanded driver	Input	E-B
SYNC ^{Note 4}	Output	P31	Clock output for externally expanded driver synchronization	Input	E-B

- Notes**
- Characters in parentheses indicate the Schmitt-triggered input.
 - Each display output selects the following V_{LCX} as input source.
S0 to S15: V_{LC1}, COM0 to COM2: V_{LC2}, COM3: V_{LC0}
 - When a split resistor is contained Low level
When no split resistor is contained High impedance
 - These pins are provided for future system expansion.
At present, these pins are used only as pins P30 and P31.

3.2 Non-Port Pins (2/2)

Pin Name	I/O	Alternate Function	Function	After Reset	I/O Circuit TYPE ^{Note}
X1	Input	–	Crystal/ceramic connection pin for the main system clock oscillation. When the external clock is used, input the external clock to pin X1, and the inverted phase of the external clock to pin X2.	–	–
X2	–				
XT1	Input	–	Crystal connection pin for the subsystem clock oscillation. When the external clock is used, input the external clock to pin XT1, and the inverted phase of the external clock to pin XT2. Pin XT1 can be used as a 1-bit input (test) pin.	–	–
XT2	–				
$\overline{\text{RESET}}$	Input	–	System reset input (low-level active)	–	(B)
IC	–	–	Internally connected. Connect directly to V_{DD} .	–	–
V_{DD}	–	–	Positive power supply	–	–
V_{SS}	–	–	Ground potential	–	–

Note Characters in parentheses indicate the Schmitt-triggered input.

3.3 Pin I/O Circuits

The μPD753108 pin input/output circuits are shown schematically.

(1/2)

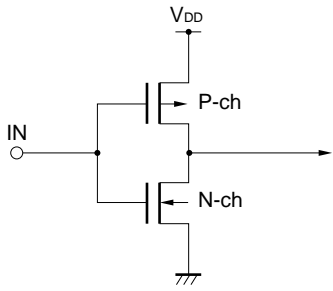
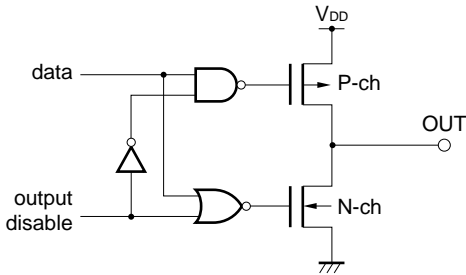
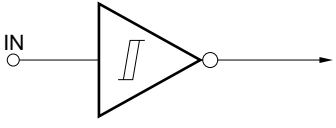
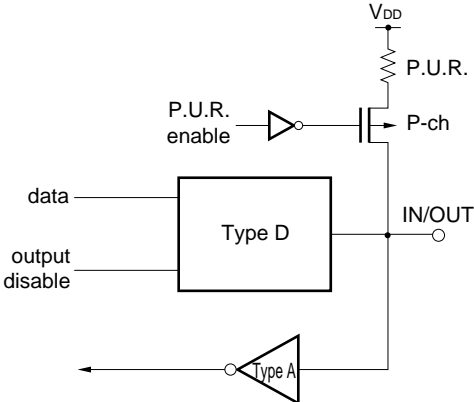
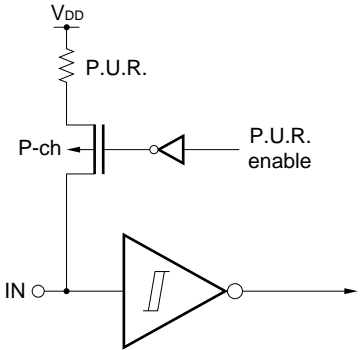
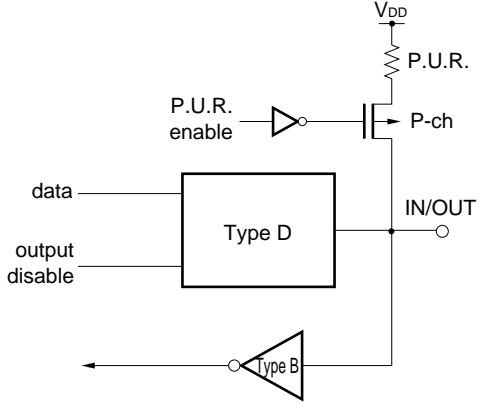
<p>TYPE A</p>  <p>CMOS standard input buffer</p>	<p>TYPE D</p>  <p>Push-pull output that can be placed in output high-impedance (both P-ch and N-ch off).</p>
<p>TYPE B</p>  <p>Schmitt-triggered input with hysteresis characteristics</p>	<p>TYPE E-B</p>  <p>P.U.R. : Pull-Up Resistor</p>
<p>TYPE B-C</p>  <p>P.U.R. : Pull-Up Resistor</p>	<p>TYPE F-A</p>  <p>P.U.R. : Pull-Up Resistor</p>

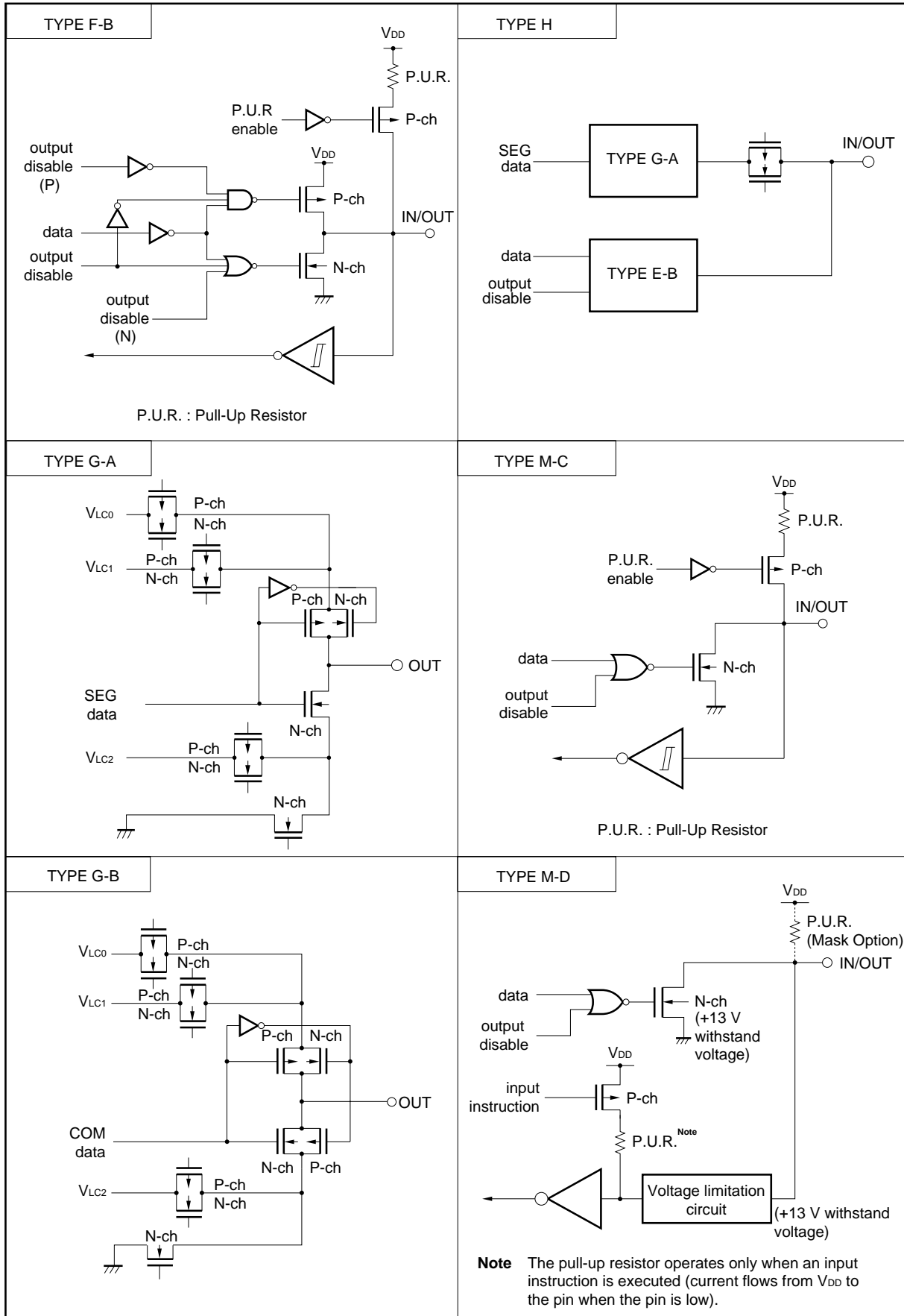

3.4 Recommended Connections of Unused Pins

Table 3-1. List of Recommended Connections for Unused Pins

Pin Name	Recommended Connection
P00/INT4	Connect to V _{SS} or V _{DD} .
P01/ $\overline{\text{SCK}}$	At input: Independently connect to V _{SS} or V _{DD} via a resistor.
P02/SO/SB0	At output: Leave open.
P03/SI/SB1	Connect to V _{SS} .
P10/INT0, P11/INT1	Connect to V _{SS} or V _{DD} .
P12/TI1/TI2/INT2	
P13/TI0	
P20/PTO0	At input: Independently connect to V _{SS} or V _{DD} via a resistor.
P21/PTO1	At output: Leave open.
P22/PCL/PTO2	
P23/BUZ	
P30/LCDCL	
P31/SYNC	
P32	
P33	
P50 to P53	
P60/KR0 to P63/KR3	At input: Independently connect to V _{SS} or V _{DD} via a resistor. At output: Leave open.
S0 to S15	Leave open.
COM0 to COM3	
S16/P93 to S19/P90	At input: Independently connect to V _{SS} or V _{DD} via a resistor.
S20/P83 to S23/P80	At output: Leave open.
V _{LC0} to V _{LC2}	Connect to V _{SS} .
BIAS	Only if all of V _{LC0} to V _{LC2} are unused, connect to V _{SS} . In other cases, leave open.
XT1 ^{Note}	Connect to V _{SS} .
XT2 ^{Note}	Leave open.
IC	Connect directly to V _{DD} .

★

Note When the subsystem clock is not used, specify SOS.0 = 1 (so as not to use the on-chip feedback resistor).

4. SWITCHING FUNCTION BETWEEN Mk I MODE AND Mk II MODE

4.1 Difference Between Mk I Mode and Mk II Mode

The CPU of the μPD753108 has the following two modes: Mk I and Mk II, either of which can be selected. The mode can be switched by bit 3 of the stack bank select register (SBS).

- Mk I mode: Upward compatible with the μPD75308B. Can be used in the 75XL CPU with a ROM capacity of up to 16 KB.
- Mk II mode: Incompatible with the μPD75308B. Can be used in all the 75XL CPU's including those products whose ROM capacity is more than 16 KB.

Table 4-1. Differences Between Mk I Mode and Mk II Mode

	Mk I Mode	Mk II Mode
Number of stack bytes for subroutine instructions	2 bytes	3 bytes
BRA !addr1 instruction CALLA !addr1 instruction	Not available	Available
CALL !addr instruction	3 machine cycles	4 machine cycles
CALLF !faddr instruction	2 machine cycles	3 machine cycles

Caution The Mk II mode supports a program area exceeding 16 KB for the 75X and 75XL Series. Therefore, this mode is effective for enhancing software compatibility with products exceeding 16 KB.

When the Mk II mode is selected, the number of stack bytes used during execution of subroutine call instructions increases by one byte per stack compared to the Mk I mode. When the CALL !addr and CALLF !faddr instructions are used, the machine cycle becomes longer by one machine cycle. Therefore, use the Mk I mode if the RAM efficiency and processing performance are more important than software compatibility.

4.2 Setting Method of Stack Bank Select Register (SBS)

Switching between the Mk I mode and Mk II mode can be done by the stack bank select register (SBS). Figure 4-1 shows the format.

The SBS is set by a 4-bit memory manipulation instruction.

When using the Mk I mode, the SBS must be initialized to 100×B^{Note} at the beginning of a program. When using the Mk II mode, it must be initialized to 000×B^{Note}.

Note Set the desired value in the × position.

Figure 4-1. Stack Bank Select Register Format

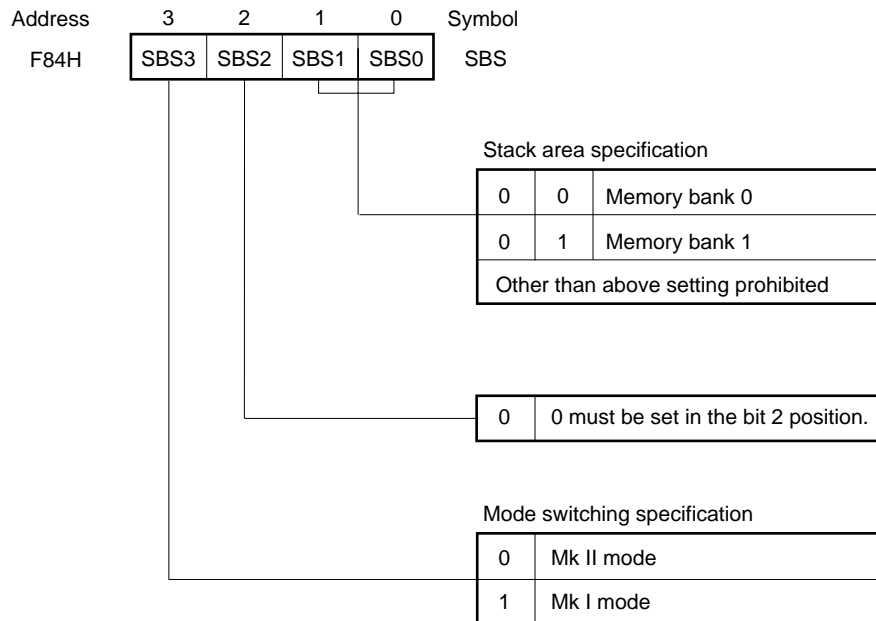

Caution Since SBS. 3 is set to “1” after a RESET signal is generated, the CPU operates in the Mk I mode. When executing an instruction in the Mk II mode, set SBS. 3 to “0” to select the Mk II mode.

5. MEMORY CONFIGURATION

- Program Memory (ROM) 4096 × 8 bits (μ PD753104)
 6144 × 8 bits (μ PD753106)
 8192 × 8 bits (μ PD753108)
 - Addresses 0000H and 0001H
Vector table wherein the program start address and the values set for the RBE and MBE at the time a $\overline{\text{RESET}}$ signal is generated are written. Reset start is possible from any address.
 - Addresses 0002H to 000DH
Vector table wherein the program start address and the values set for the RBE and MBE by each vectored interrupt are written. Interrupt processing can start from any address.
 - Addresses 0020H to 007FH
Table area referenced by the GETI instruction^{Note}.
- Note** The GETI instruction realizes a 1-byte instruction on behalf of any 2-byte instruction, 3-byte instruction, or two 1-byte instructions. It is used to decrease the number of program steps.
- Data Memory (RAM)
 - Data area ... 512 words × 4 bits (000H to 1FFH)
 - Peripheral hardware area ... 128 words × 4 bits (F80H to FFFH)

Figure 5-1. Program Memory Map (1/3)

(a) μPD753104

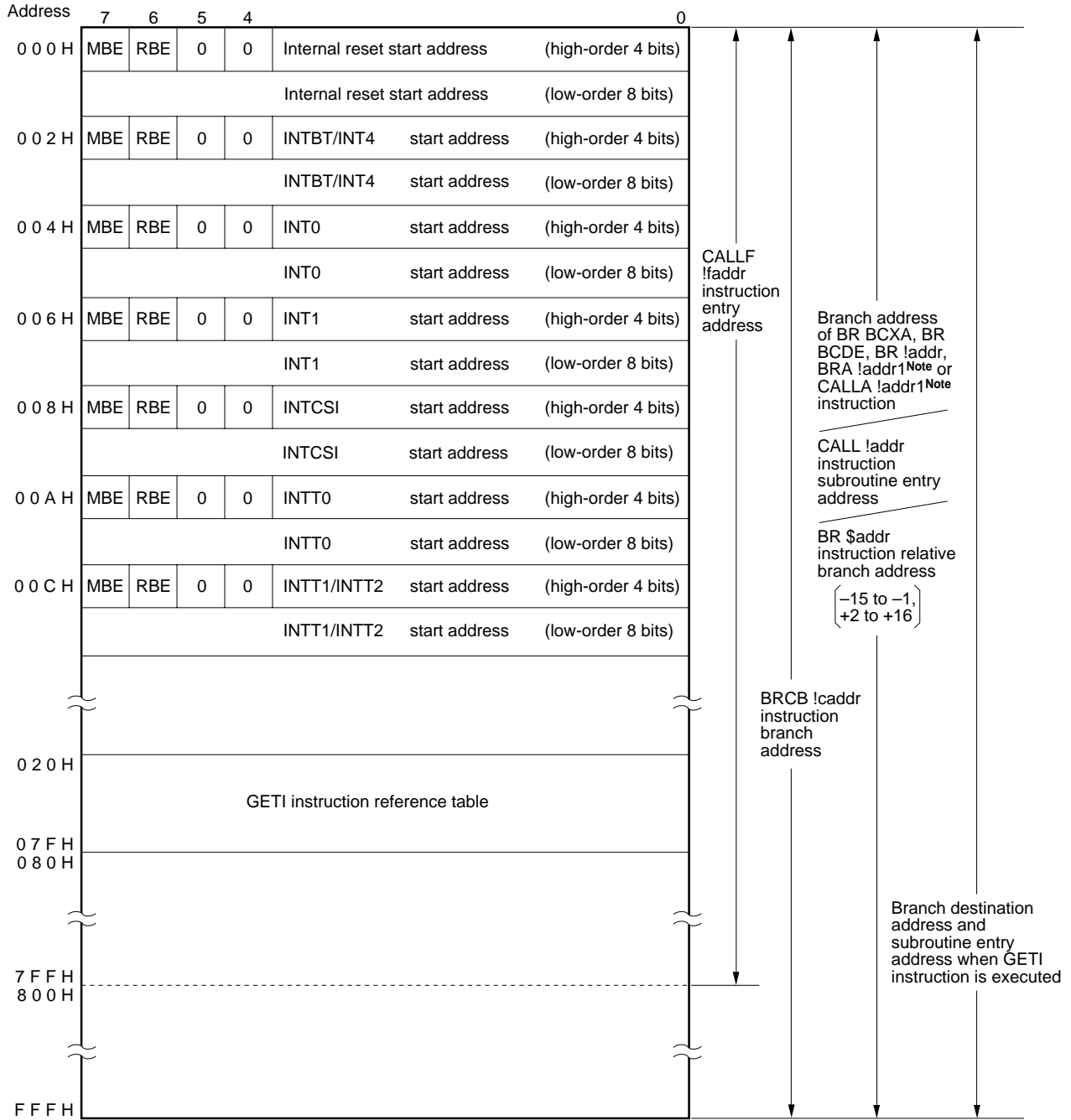

Note Can be used in Mk II mode only.

Remark In addition to the above, a branch can be taken to the address indicated by changing only the low-order eight bits of PC by executing the BR PCDE or BR PCXA instruction.

Figure 5-1. Program Memory Map (2/3)

(b) μPD753106

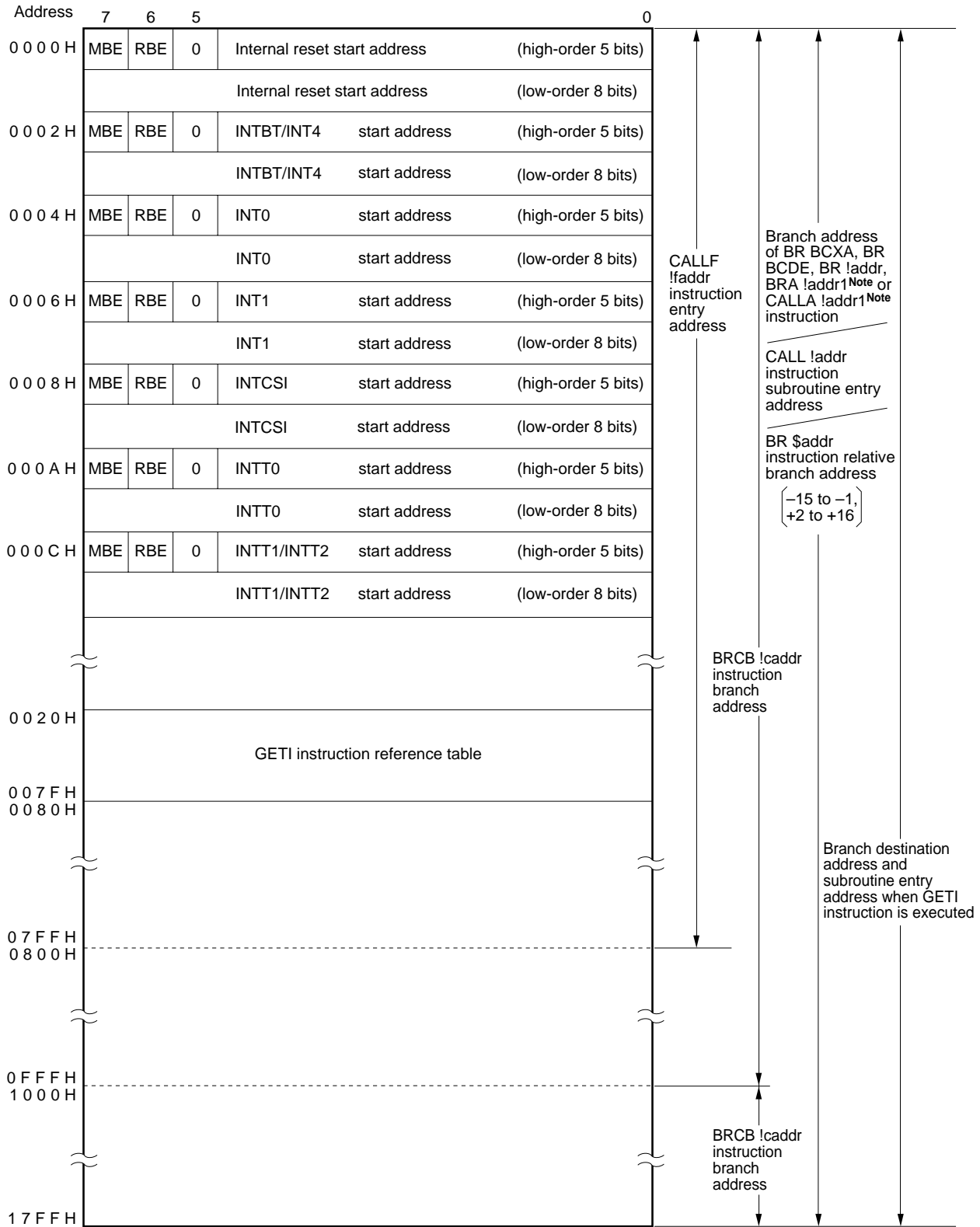

Note Can be used in Mk II mode only.

Remark In addition to the above, a branch can be taken to the address indicated by changing only the low-order eight bits of PC by executing the BR PCDE or BR PCXA instruction.

Figure 5-1. Program Memory Map (3/3)

(c) μPD753108

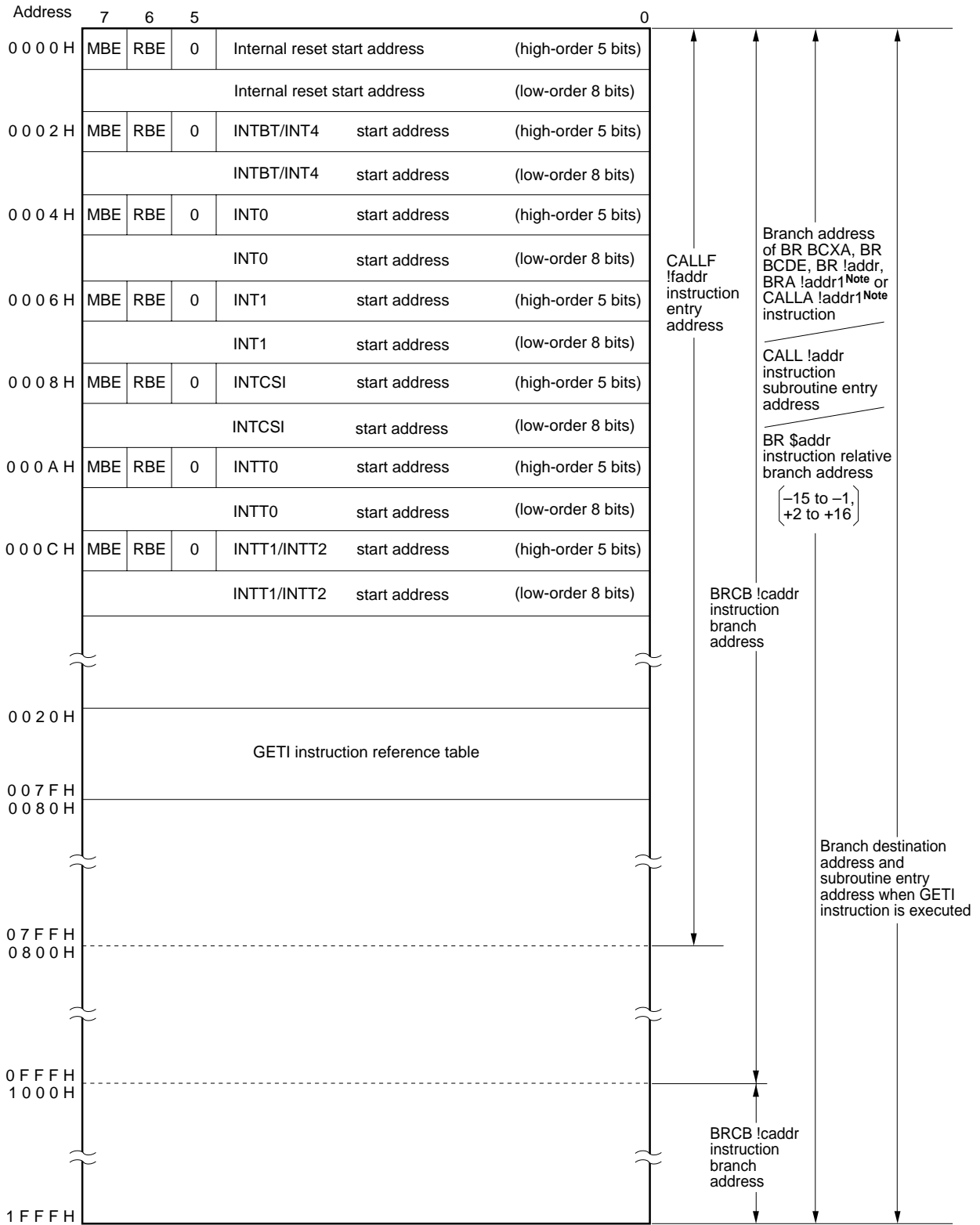

Note Can be used in Mk II mode only.

Remark In addition to the above, a branch can be taken to the address indicated by changing only the low-order eight bits of PC by executing the BR PCDE or BR PCXA instruction.

Figure 5-2. Data Memory Map

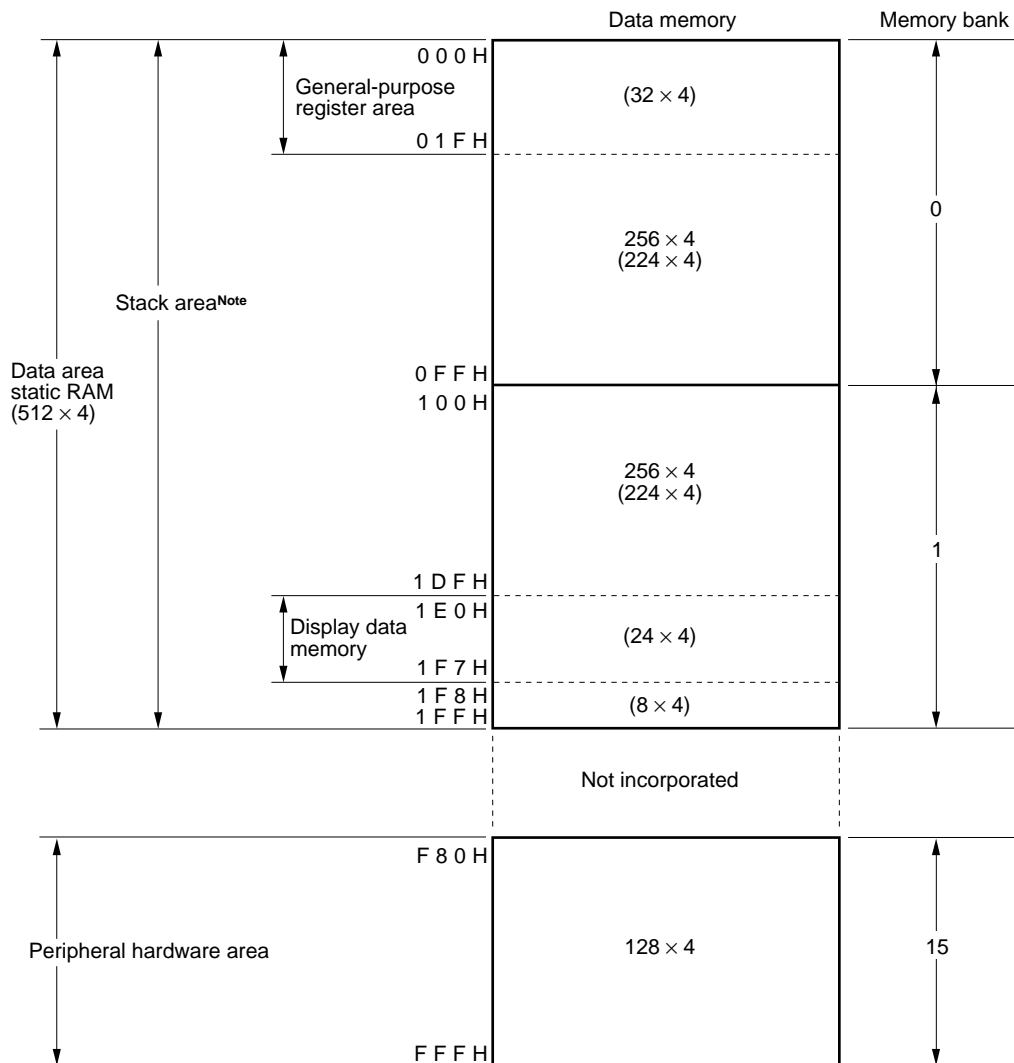

Note Either memory bank 0 or 1 can be selected for the stack area.

6. PERIPHERAL HARDWARE FUNCTION

6.1 Digital I/O Port

There are three kinds of I/O port.

- CMOS input ports (PORT 0, 1): 8
 - CMOS I/O ports (PORT 2, 3, 6, 8, 9): 20
 - N-ch open-drain I/O ports (PORT 5): 4
-
- Total 32

Table 6-1. Types and Features of Digital Ports

Port Name	Function	Operation and Features		Remarks
PORT0	4-bit input	When the serial interface function is used, the alternate function pins function as output ports depending on the operation mode.		Also used for the INT4, \overline{SCK} , SO/SB0, SI/SB1 pins.
PORT1		4-bit input only port.		Also used for the INT0 to INT2/TI1/TI2, TIO pins.
PORT2	4-bit I/O	Input/output can be specified in 4-bit units.		Also used for the PTO0 to PTO2/PCL, BUZ pins.
PORT3		Input/output can be specified in 1-bit units.		Also used for the LCDCL, SYNC pins.
PORT5	4-bit I/O (N-ch open-drain, 13 V withstand voltage)	Input/output can be specified in 4-bit units. On-chip pull-up resistor can be specified in 1-bit units by mask option.		—
PORT6	4-bit I/O	Input/output can be specified in 1-bit units.		Also used for the KR0 to KR3 pins.
PORT8		Input/output can be specified in 4-bit units.	Ports 8 and 9 are paired and data can be input/output in 8-bit units.	Also used for the S20 to S23 pins.
PORT9				Also used for the S16 to S19 pins.

6.2 Clock Generator

The clock generator is a device that generates the clock which is supplied to peripheral hardware on the CPU and is configured as shown in Figure 6-1.

The clock generator operates according to how the processor clock control register (PCC) and system clock control register (SCC) are set.

There are two kinds of clocks, main system clock and subsystem clock.

The instruction execution time can also be changed.

- 0.95, 1.91, 3.81, 15.3 μs (main system clock: @ 4.19 MHz operation)
- 0.67, 1.33, 2.67, 10.7 μs (main system clock: @ 6.0 MHz operation)
- 122 μs (subsystem clock: @ 32.768 kHz operation)

Figure 6-1. Clock Generator Block Diagram

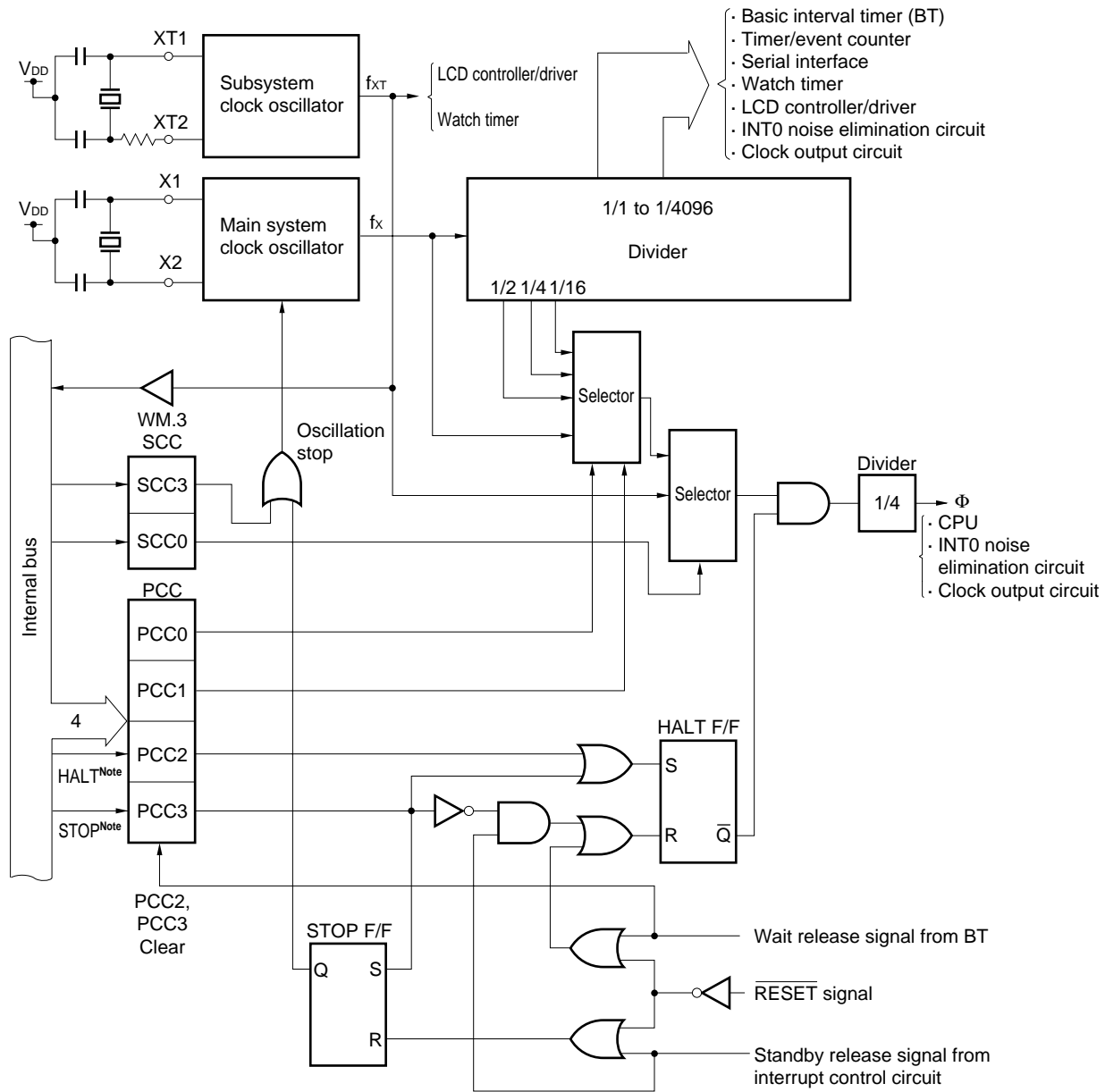

Note Instruction execution

- Remarks 1.** f_x = Main system clock frequency
 2. f_{XT} = Subsystem clock frequency
 3. Φ = CPU clock
 4. PCC: Processor Clock Control register
 5. SCC: System Clock Control register
 6. One clock cycle (t_{CY}) of the CPU clock is equal to one machine cycle of the instruction.

6.3 Subsystem Clock Oscillator Control Functions

The μPD753108 subsystem clock oscillator has the following two control functions.

- Selects by means of software whether an on-chip feedback resistor is to be used or not^{Note}.
- Reduces current consumption by decreasing the drive current of the on-chip inverter when the supply voltage is high ($V_{DD} \geq 2.7$ V).

★ **Note** When the subsystem clock is not used, set SOS.0 to 1 (so as not to use the on-chip feedback resistor) by software, connect XT1 to V_{SS} , and leave XT2 open. This makes it possible to reduce the current consumption in the subsystem clock oscillator.

The above functions can be used by switching the bits 0 and 1 of the sub-oscillator control register (SOS). (See Figure 6-2.)

Figure 6-2. Subsystem Clock Oscillator

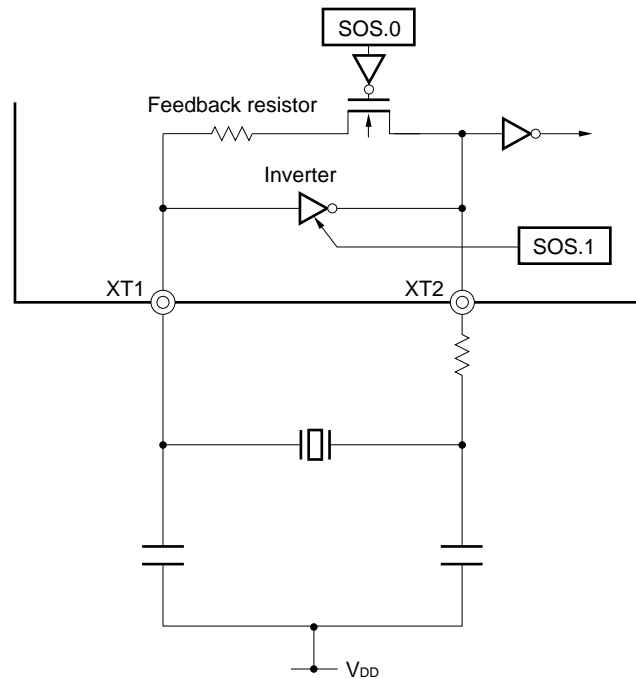

6.4 Clock Output Circuit

The clock output circuit is provided to output the clock pulses from the P22/PTO2/PCL pin to the remote control wave outputs and peripheral LSI's.

- Clock output (PCL): Φ , 524, 262, 65.5 kHz (main system clock: @ 4.19 MHz operation)
 Φ , 750, 375, 93.8 kHz (main system clock: @ 6.0 MHz operation)

Figure 6-3. Clock Output Circuit Block Diagram

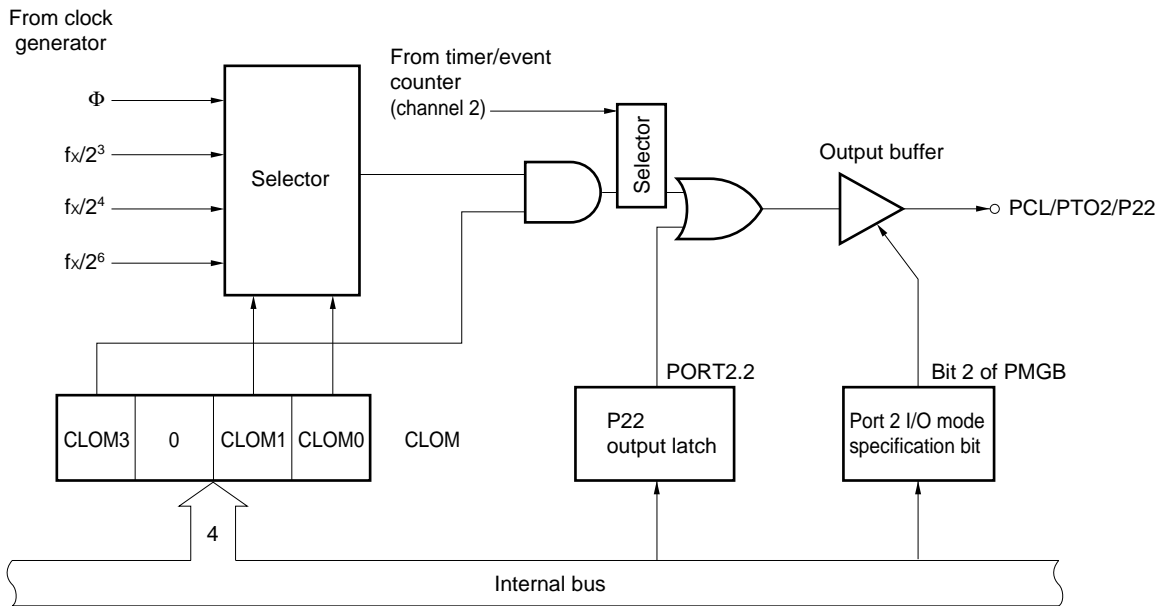

Remark Special care has been taken in designing the chip so that small-width pulses may not be output when switching clock output enable/disable.

6.5 Basic Interval Timer/Watchdog Timer

The basic interval timer/watchdog timer has the following functions.

- Interval timer operation to generate a reference time interrupt
- Watchdog timer operation to detect a runaway of program and reset the CPU
- Selects and counts the wait time when the standby mode is released
- Reads the contents of counting

Figure 6-4. Basic Interval Timer/Watchdog Timer Block Diagram

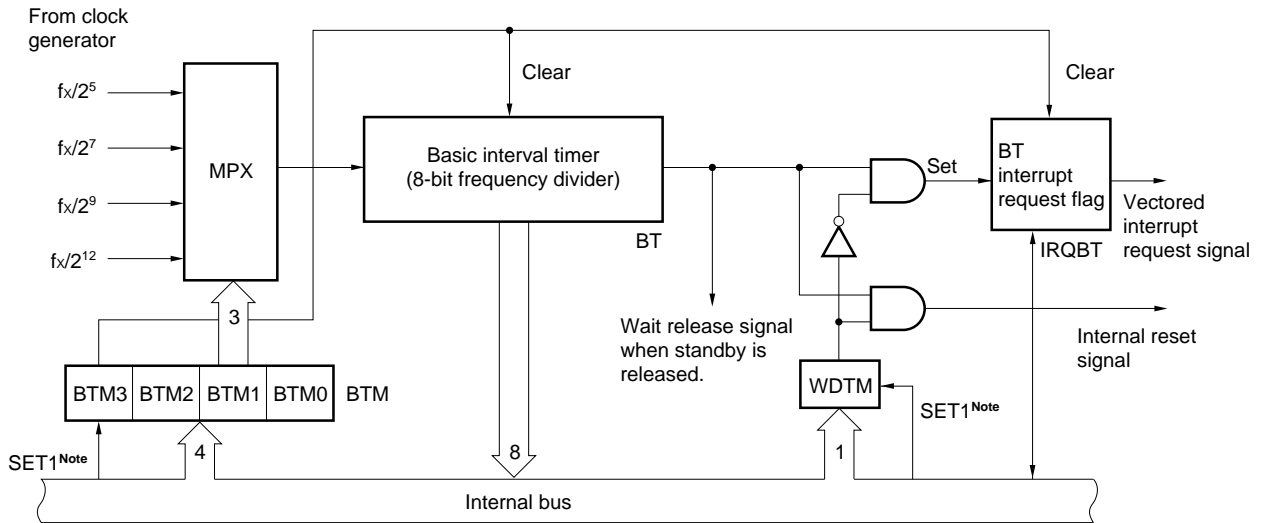

Note Instruction execution

6.6 Watch Timer

The μPD753108 has one watch timer channel which has the following functions.

- Sets the test flag (IRQW) at 0.5-second intervals. The standby mode can be released by the IRQW.
- ★ ● 0.5-second interval can be created by both the main system clock (4.19 MHz) and subsystem clock (32.768 kHz).
- Convenient for program debugging and checking as interval becomes 128 times longer (3.91 ms) with the fast feed mode.
- Outputs the frequencies (2.048, 4.096, 32.768 kHz) to the P23/BUZ pin, usable for buzzer and trimming of system clock oscillation frequencies.
- Clears the frequency divider to make the watch start with zero seconds.

Figure 6-5. Watch Timer Block Diagram

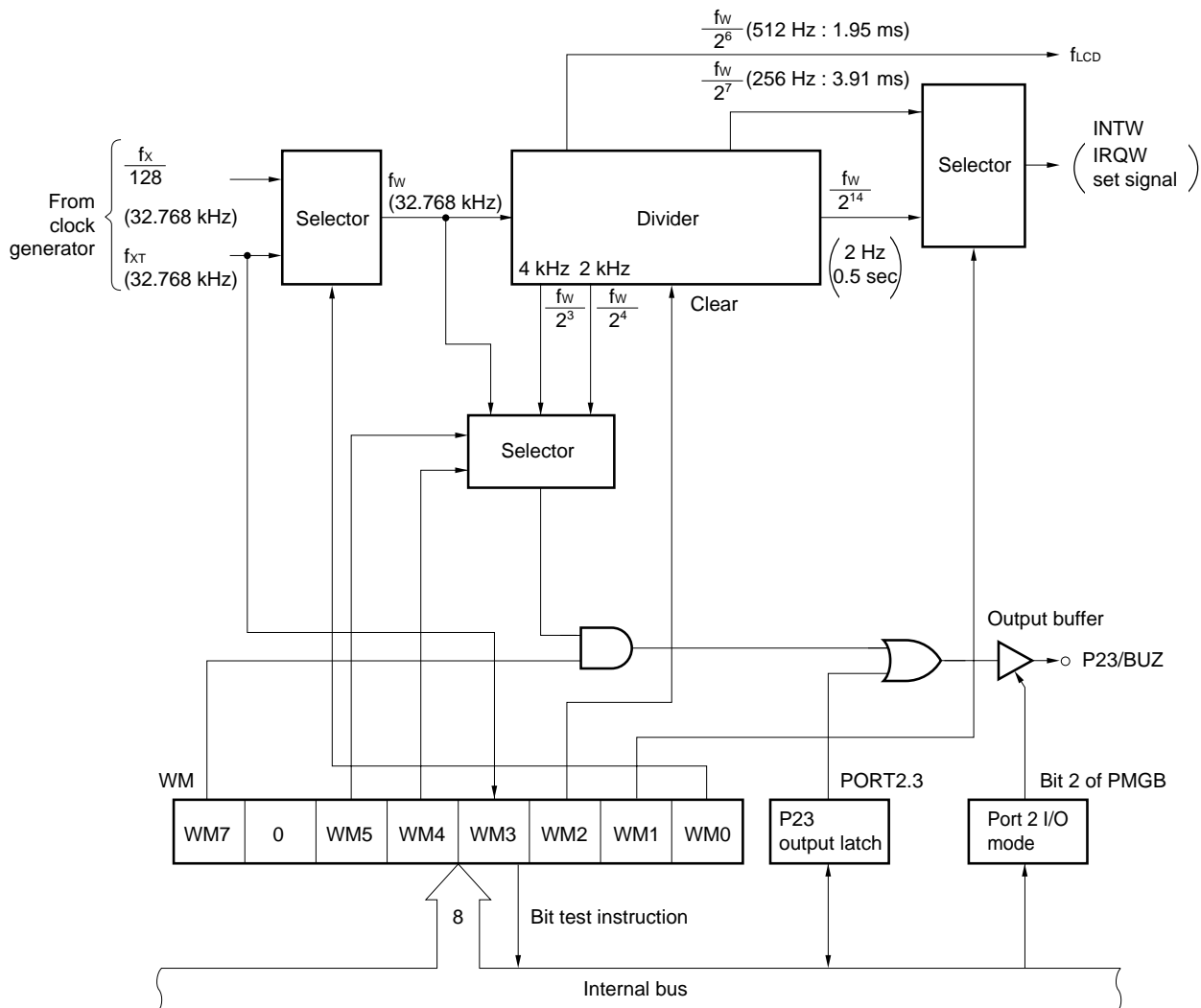

★ **Remark** The values enclosed in parentheses are applied when $f_x = 4.19 \text{ MHz}$ and $f_{xT} = 32.768 \text{ kHz}$.

6.7 Timer/Event Counter

The μPD753108 has three channels of timer/event counters. Its configuration is shown in Figures 6-6 to 6-8. The timer/event counter has the following functions.

- Programmable interval timer operation
- Square wave output of any frequency to the PTO_n pin (n = 0 to 2)
- Event counter operation
- Divides the frequency of signal input via the TIn pin to 1-Nth of the original signal and outputs the divided frequency to the PTO_n pin (frequency divider operation).
- Supplies the serial shift clock to the serial interface circuit.
- Reads the count value.

The timer/event counter operates in the following four modes as set by the mode register.

Table 6-2. Operation Modes of Timer/Event Counter

Mode	Channel	Channel 0	Channel 1	Channel 2
	8-bit timer/event counter mode		Yes	Yes
	Gate control function	No ^{Note}	No	Yes
PWM pulse generator mode		No	No	Yes
16-bit timer/event counter mode		No	Yes	
	Gate control function	No ^{Note}	Yes	
Carrier generator mode		No	Yes	

Note Used for gate control signal generation

Figure 6-7. Timer/Event Counter (Channel 1) Block Diagram

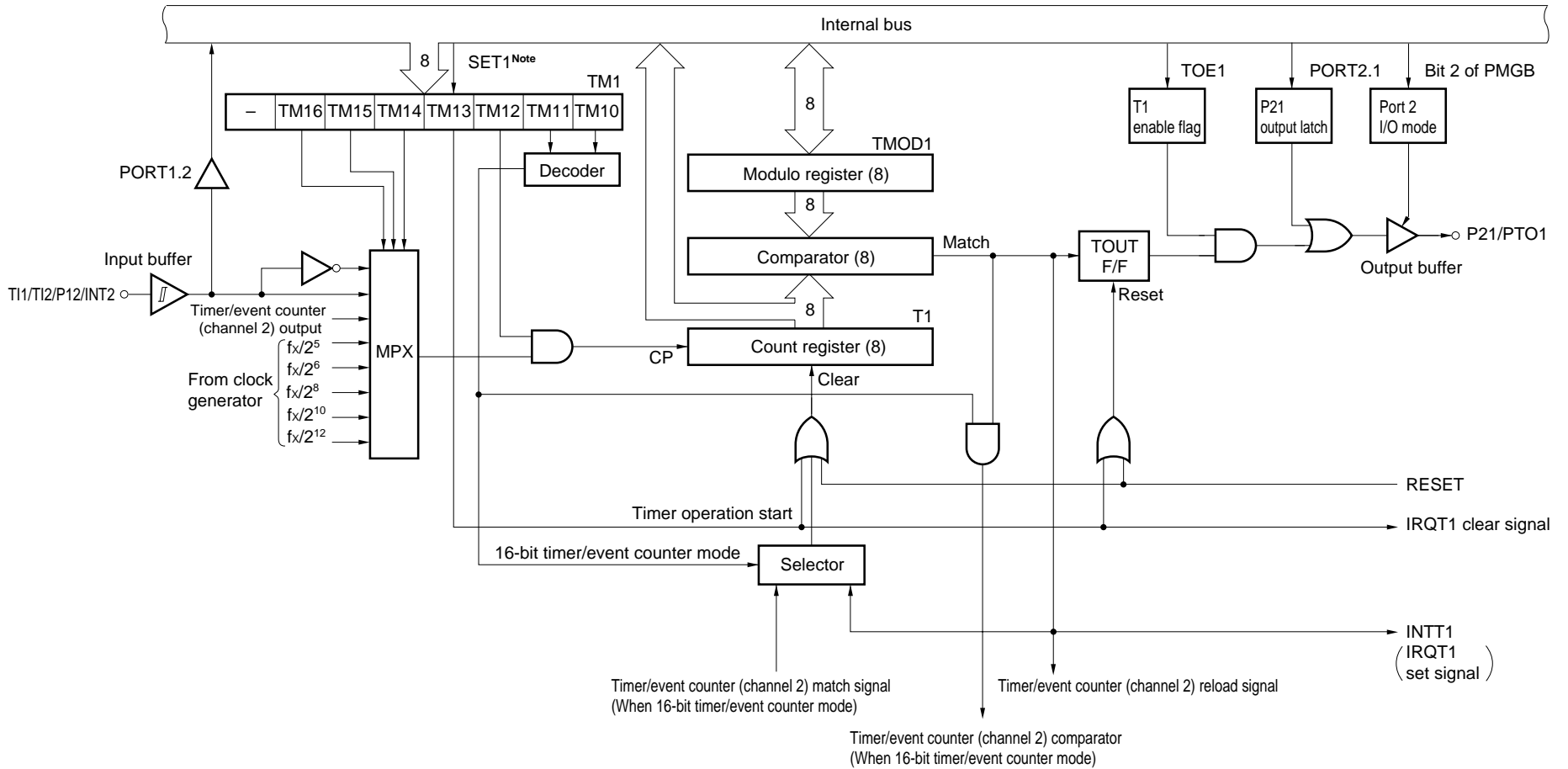

Note Instruction execution

★ Figure 6-8. Timer/Event Counter (Channel 2) Block Diagram

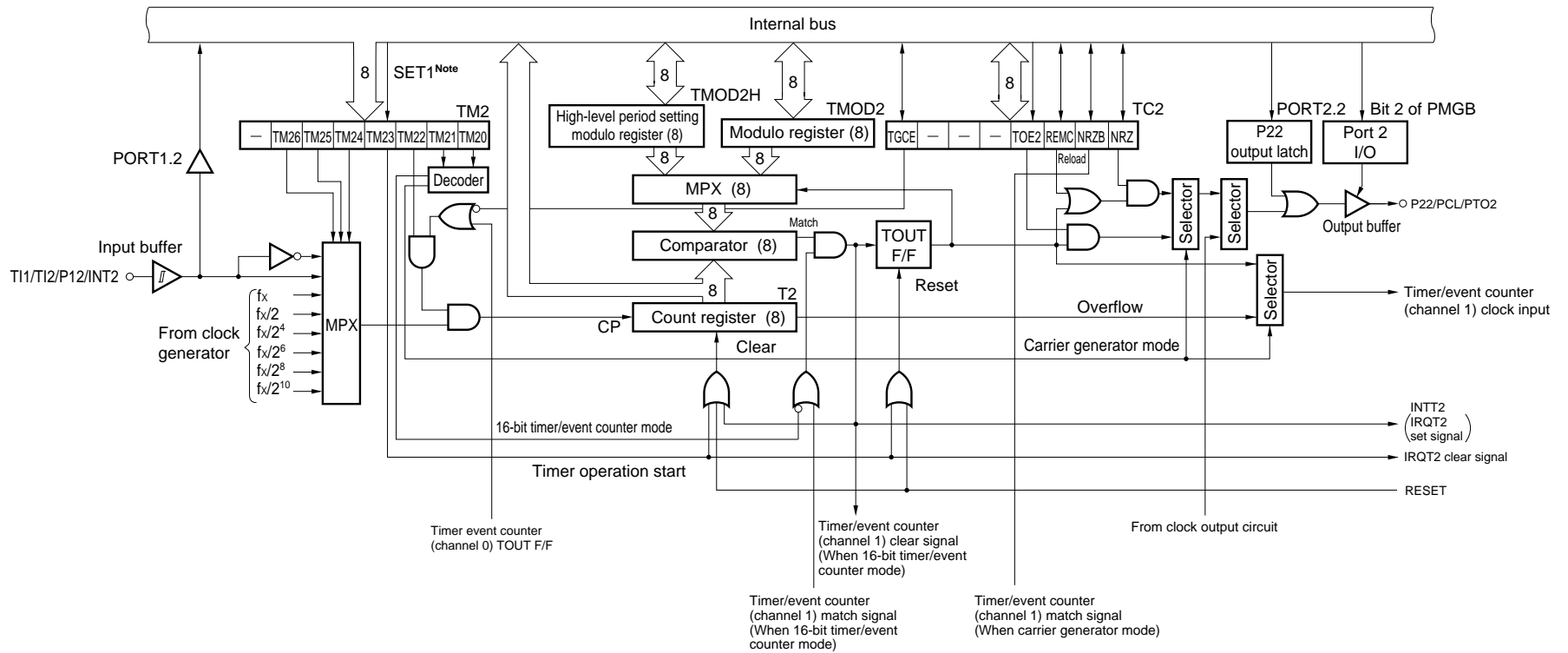

Note Instruction execution

6.8 Serial Interface

The μPD753108 incorporates a clock-synchronous 8-bit serial interface. The serial interface can be used in the following four modes.

- Operation stop mode
- 3-wire serial I/O mode
- 2-wire serial I/O mode
- SBI mode

Figure 6-9. Serial Interface Block Diagram

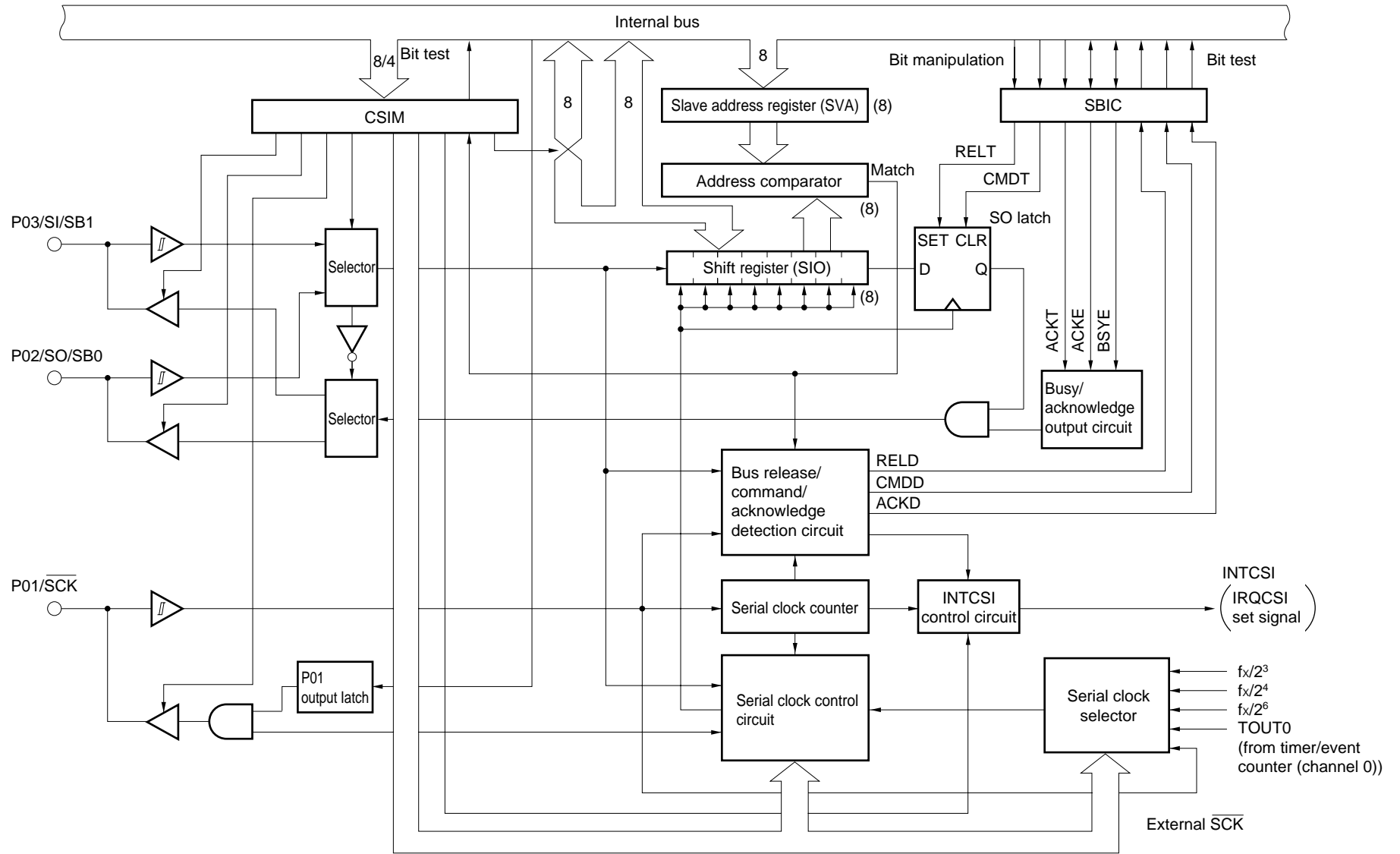

6.9 LCD Controller/Driver

The μ PD753108 incorporates a display controller which generates segment and common signals according to the display data memory contents and incorporates segment and common drivers which can drive the LCD panel directly.

The μ PD753108 LCD controller/driver has the following functions:

- Display data memory is read automatically by DMA operation and segment and common signals are generated.
- Display mode can be selected from among the following five:
 - <1> Static
 - <2> 1/2 duty (time-divided by 2), 1/2 bias
 - <3> 1/3 duty (time-divided by 3), 1/2 bias
 - <4> 1/3 duty (time-divided by 3), 1/3 bias
 - <5> 1/4 duty (time-divided by 4), 1/3 bias
- A frame frequency can be selected from among four in each display mode.
- A maximum of 24 segment signal output pins (S0 to S23) and four common signal output pins (COM0 to COM3).
- The segment signal output pins (S0 to S23) can be changed to the I/O ports (PORT8 and PORT9).
- Split resistor can be incorporated to supply LCD drive power (mask option).
 - Various bias methods and LCD drive voltages are applicable.
 - When display is off, current flowing through the split resistor is cut.
- Display data memory not used for display can be used for normal data memory.
- It can also operate by using the subsystem clock.

Figure 6-10. LCD Controller/Driver Block Diagram

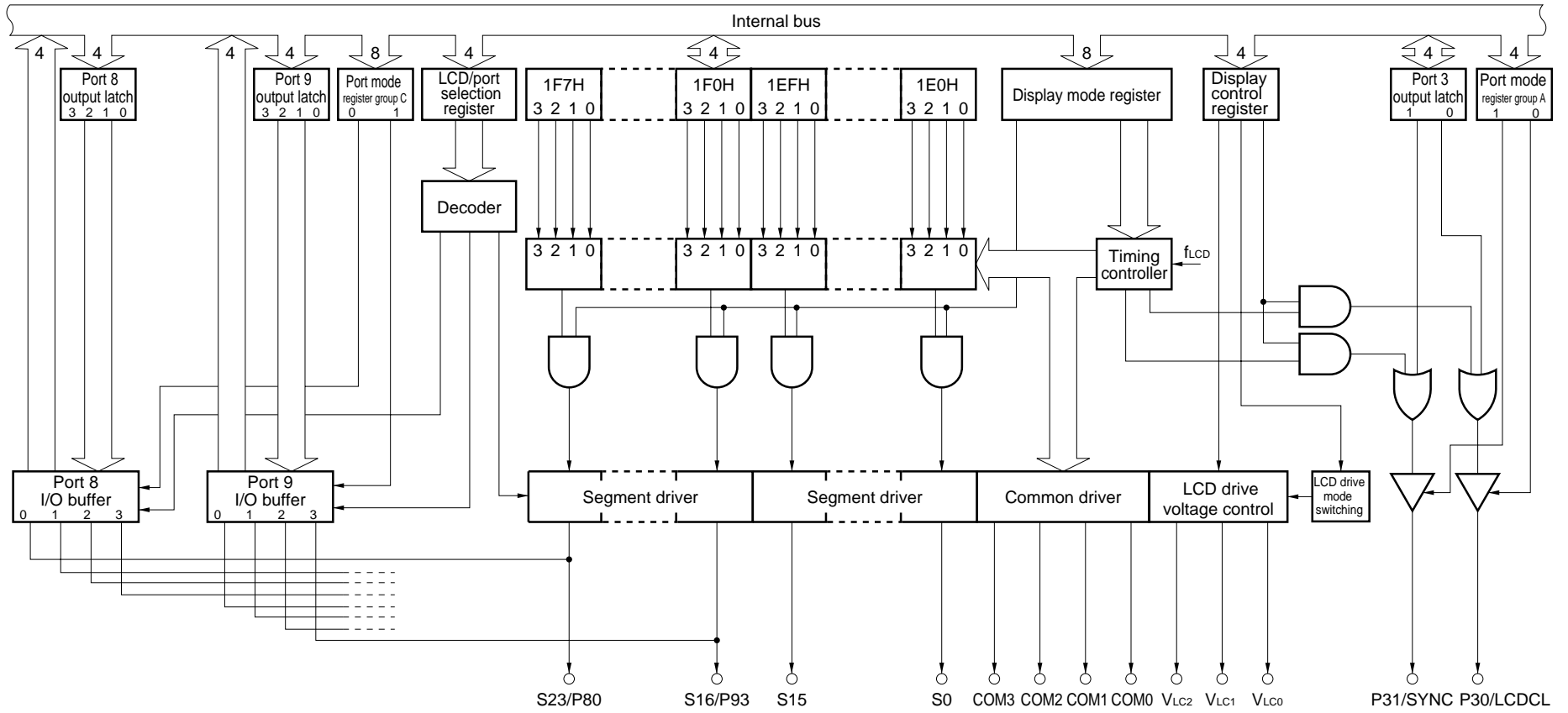

6.10 Bit Sequential Buffer 16 Bits

The bit sequential buffer (BSB) is a special data memory for bit manipulation and the bit manipulation can be easily performed by changing the address specification and bit specification in sequence, therefore it is useful when processing a long data bit-wise.

Figure 6-11. Bit Sequential Buffer Format

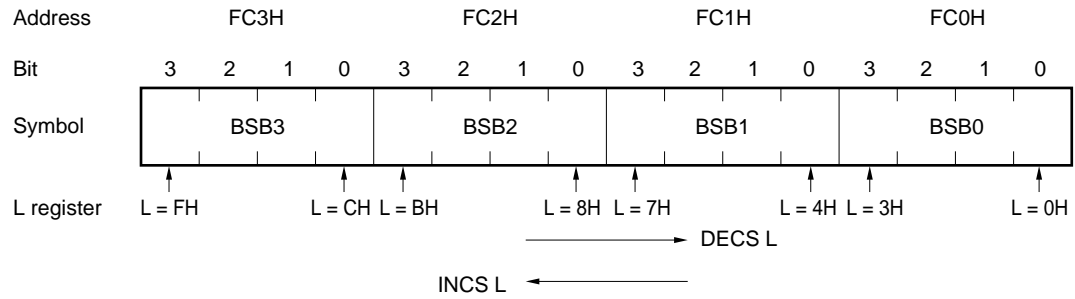

- Remarks 1.** In the pmem.@L addressing, the specified bit moves corresponding to the L register.
2. In the pmem.@L addressing, the BSB can be manipulated regardless of MBE/MBS specification.

7. INTERRUPT FUNCTION AND TEST FUNCTION

The μ PD753108 has eight types of interrupt sources and two types of test sources. Of these test sources, INT2 has two types of edge detection testable inputs.

The interrupt control circuit of the μ PD753108 has the following functions.

(1) Interrupt function

- Vectored interrupt function for hardware control, enabling/disabling the interrupt acceptance by the interrupt enable flag (IE $\times\times\times$) and interrupt master enable flag (IME).
- Can set any interrupt start address.
- Multiple interrupts wherein the order of priority can be specified by the interrupt priority select register (IPS).
- Test function of interrupt request flag (IRQ $\times\times\times$). An interrupt generation can be checked by software.
- Release the standby mode. An interrupt to be released can be selected by the interrupt enable flag.

(2) Test function

- Test request flag (IRQ $\times\times\times$) generation can be checked by software.
- Release the standby mode. The test source to be released can be selected by the test enable flag.

Figure 7-1. Interrupt Control Circuit Block Diagram

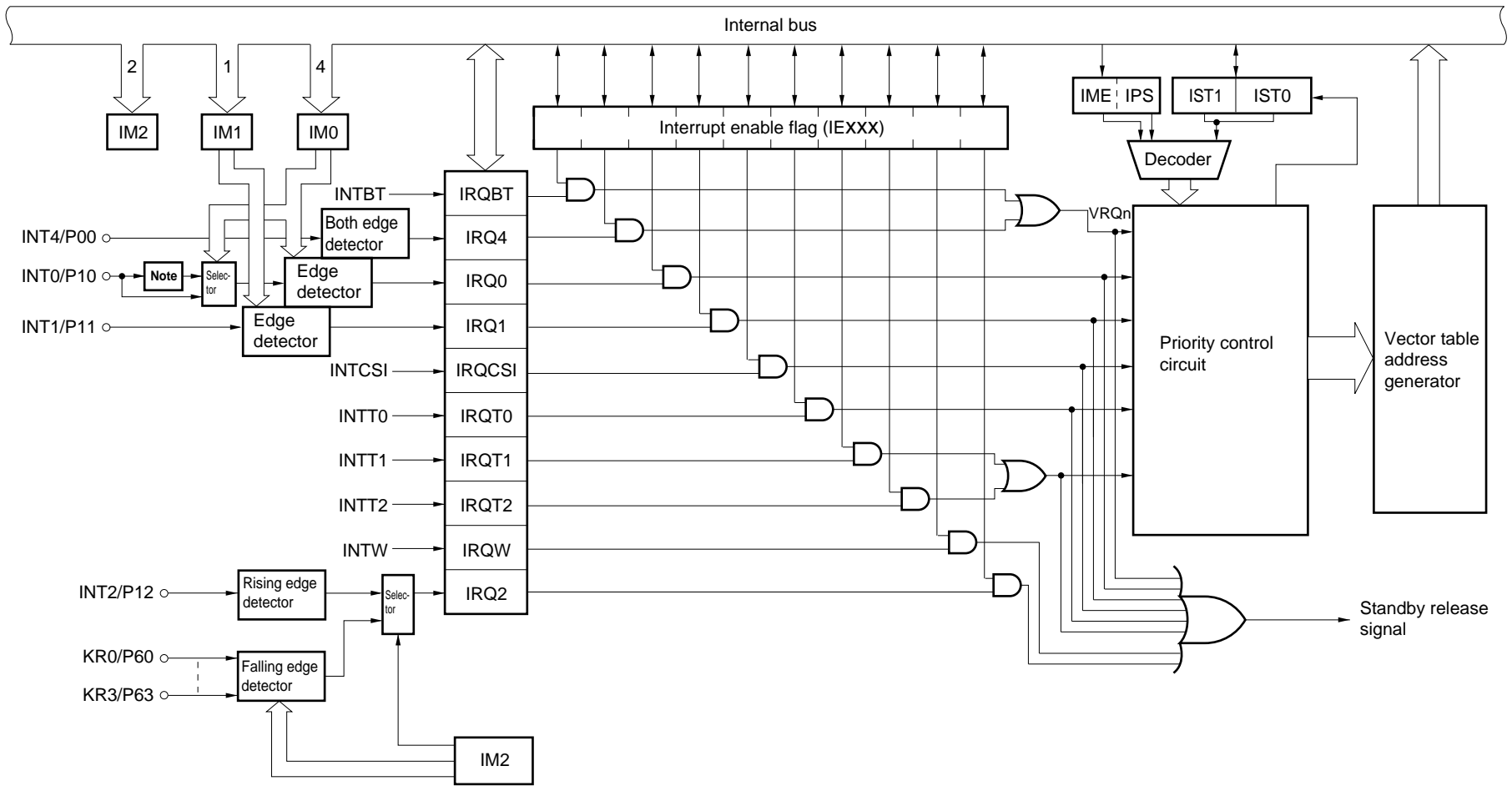

Note Noise elimination circuit (Standby release is disabled when noise elimination circuit is selected.)

8. STANDBY FUNCTION

In order to reduce power dissipation while a program is in a standby mode, two types of standby modes (STOP mode and HALT mode) are provided for the μPD753108.

Table 8-1. Operation Status in Standby Mode

Item		Mode	STOP Mode	HALT Mode
Set instruction			STOP instruction	HALT instruction
System clock when set			Settable only when the main system clock is used.	Settable both by the main system clock and subsystem clock.
Operation status	Clock generator		Main system clock stops oscillation.	Only the CPU clock Φ halts (oscillation continues).
	Basic interval timer/ watchdog timer		Operation stops.	Operable only when the main system clock is oscillated. <div style="border: 1px solid black; border-radius: 10px; padding: 5px; display: inline-block;"> BT mode : IRQBT is set in the reference time interval WT mode: Reset signal is generated by BT overflow </div>
	Serial interface		Operable only when an external \overline{SCK} input is selected as the serial clock.	Operable only when an external \overline{SCK} input is selected as the serial clock or when the main system clock is oscillated.
	Timer/event counter		Operable only when a signal input to the TI0 to TI2 pins is specified as the count clock.	Operable only when a signal input to the TI0 to TI2 pins is specified as the count clock or when the main system clock is oscillated.
	Watch timer		Operable when f_{XT} is selected as the count clock.	Operable.
	LCD controller/driver		Operable only when f_{XT} is selected as the LCDCL.	Operable.
	External interrupt		The INT1, 2, and 4 are operable. Only the INT0 is not operated ^{Note} .	
	CPU		The operation stops.	
Release signal			<ul style="list-style-type: none"> • Interrupt request signal sent from the operable hardware enabled by the interrupt enable flag • Test request signal sent from the test source enabled by the test enable flag • \overline{RESET} pin 	

★

Note Can operate only when the noise elimination circuit is not used (IM02 = 1) by bit 2 of the edge detection mode register (IM0).

9. RESET FUNCTION

There are two reset inputs: external reset signal ($\overline{\text{RESET}}$) and reset signal sent from the basic interval timer/watchdog timer. When either one of the reset signals are input, an internal reset signal is generated. Figure 9-1 shows the configuration of the above two inputs.

Figure 9-1. Configuration of Reset Function

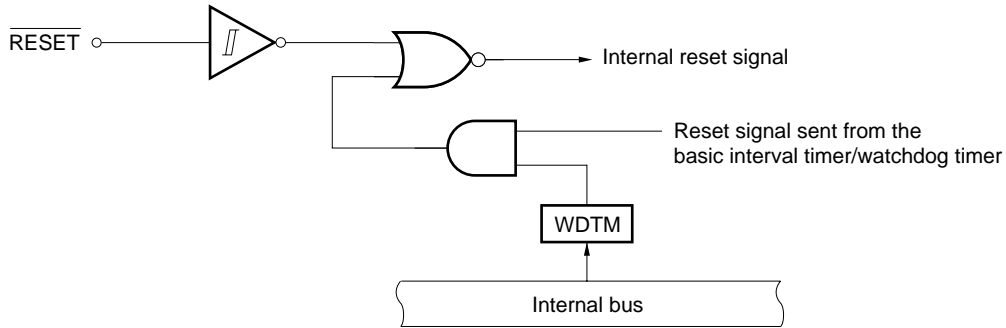

Generation of the $\overline{\text{RESET}}$ signal initializes each hardware as listed in Table 9-1. Figure 9-2 shows the timing chart of the reset operation.

Figure 9-2. Reset Operation by $\overline{\text{RESET}}$ Signal Generation

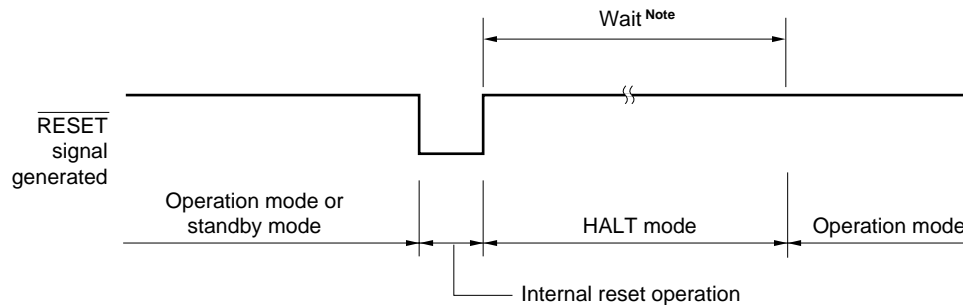

Note The following two times can be selected by the mask option.
 $2^{17}/f_x$ (21.8 ms: @ 6.00 MHz operation, 31.3 ms: @ 4.19 MHz operation)
 $2^{15}/f_x$ (5.46 ms: @ 6.00 MHz operation, 7.81 ms: @ 4.19 MHz operation)

Table 9-1. Status of Each Hardware After Reset (1/2)

Hardware		RESET Signal Generation in the Standby Mode	RESET Signal Generation in Operation
Program counter (PC)	μPD753104	Sets the low-order 4 bits of program memory's address 0000H to the PC11 to PC8 and the contents of address 0001H to the PC7 to PC0.	Sets the low-order 4 bits of program memory's address 0000H to the PC11 to PC8 and the contents of address 0001H to the PC7 to PC0.
	μPD753106, μPD753108	Sets the low-order 5 bits of program memory's address 0000H to the PC12 to PC8 and the contents of address 0001H to the PC7 to PC0.	Sets the low-order 5 bits of program memory's address 0000H to the PC12 to PC8 and the contents of address 0001H to the PC7 to PC0.
PSW	Carry flag (CY)	Held	Undefined
	Skip flag (SK0 to SK2)	0	0
	Interrupt status flag (IST0, IST1)	0	0
	Bank enable flag (MBE, RBE)	Sets the bit 6 of program memory's address 0000H to the RBE and bit 7 to the MBE.	Sets the bit 6 of program memory's address 0000H to the RBE and bit 7 to the MBE.
Stack pointer (SP)		Undefined	Undefined
Stack bank select register (SBS)		1000B	1000B
Data memory (RAM)		Held	Undefined
General-purpose register (X, A, H, L, D, E, B, C)		Held	Undefined
Bank select register (MBS, RBS)		0, 0	0, 0
Basic interval timer/watchdog timer	Counter (BT)	Undefined	Undefined
	Mode register (BTM)	0	0
	Watchdog timer enable flag (WDTM)	0	0
Timer/event counter (T0)	Counter (T0)	0	0
	Modulo register (TMOD0)	FFH	FFH
	Mode register (TM0)	0	0
	TOE0, TOUT F/F	0, 0	0, 0
Timer/event counter (T1)	Counter (T1)	0	0
	Modulo register (TMOD1)	FFH	FFH
	Mode register (TM1)	0	0
	TOE1, TOUT F/F	0, 0	0, 0
Timer/event counter (T2)	Counter (T2)	0	0
	Modulo register (TMOD2)	FFH	FFH
	High-level period setting modulo register (TMOD2H)	FFH	FFH
	Mode register (TM2)	0	0
	TOE2, TOUT F/F	0, 0	0, 0
	REMC, NRZ, NRZB	0, 0, 0	0, 0, 0
	TGCE	0	0
Watch timer	Mode register (WM)	0	0

Table 9-1. Status of Each Hardware After Reset (2/2)

Hardware		RESET Signal Generation in the Standby Mode	RESET Signal Generation in Operation
Serial interface	Shift register (SIO)	Held	Undefined
	Operation mode register (CSIM)	0	0
	SBI control register (SBIC)	0	0
	Slave address register (SVA)	Held	Undefined
Clock generator, clock output circuit	Processor clock control register (PCC)	0	0
	System clock control register (SCC)	0	0
	Clock output mode register (CLOM)	0	0
Sub-oscillator control register (SOS)		0	0
LCD controller/driver	Display mode register (LCDM)	0	0
	Display control register (LCDC)	0	0
	LCD/port selection register (LPS)	0	0
Interrupt function	Interrupt request flag (IRQxxx)	Reset (0)	Reset (0)
	Interrupt enable flag (IExxx)	0	0
	Interrupt priority selection register (IPS)	0	0
	INT0, 1, 2 mode registers (IM0, IM1, IM2)	0, 0, 0	0, 0, 0
Digital port	Output buffer	Off	Off
	Output latch	Cleared (0)	Cleared (0)
	I/O mode registers (PMGA, B, C)	0	0
	Pull-up resistor setting register (POGA, B)	0	0
Bit sequential buffer (BSB0 to BSB3)		Held	Undefined

10. MASK OPTION

The μ PD753108 has the following mask options.

- Mask options of P50 to P53
Selects whether or not to internally connect a pull-up resistor.
<1> Connect pull-up resistor internally in 1-bit units.
<2> Do not connect pull-up resistor internally.
- V_{LC0} to V_{LC2} pins, BIAS pin mask option
Selects whether or not to internally connect LCD-driving split resistors.
<1> Do not connect split resistor internally.
<2> Connect four 10 k Ω (TYP.) split resistors simultaneously internally.
<3> Connect four 100 k Ω (TYP.) split resistors simultaneously internally.
- Standby function mask option
Selects the wait time with the $\overline{\text{RESET}}$ signal.
<1> $2^{17}/f_x$ (21.8 ms: @ $f_x = 6.0$ MHz operation, 31.3 ms: @ $f_x = 4.19$ MHz operation)
<2> $2^{15}/f_x$ (5.46 ms: @ $f_x = 6.0$ MHz operation, 7.81 ms: @ $f_x = 4.19$ MHz operation)

11. INSTRUCTION SET

(1) Expression formats and description methods of operands

★ The operand is described in the operand column of each instruction in accordance with the description method for the operand expression format of the instruction. For details, refer to “**RA75X ASSEMBLER PACKAGE USERS’ MANUAL—LANGUAGE (U12385E)**”. If there are several elements, one of them is selected. Capital letters and the + and – symbols are key words and are described as they are. For immediate data, appropriate numbers and labels are described. Instead of the labels such as mem, fmem, pmem, and bit, the symbols of the register flags can be described. However, there are restrictions in the labels that can be described for fmem and pmem. For details, see **User’s Manual**.

Expression Format	Description Method
reg reg1	X, A, B, C, D, E, H, L X, B, C, D, E, H, L
rp rp1 rp2 rp' rp'1	XA, BC, DE, HL BC, DE, HL BC, DE XA, BC, DE, HL, XA', BC', DE', HL' BC, DE, HL, XA', BC', DE', HL'
rpa rpa1	HL, HL+, HL–, DE, DL DE, DL
n4 n8	4-bit immediate data or label 8-bit immediate data or label
mem bit	8-bit immediate data or label ^{Note} 2-bit immediate data or label
fmem pmem	FB0H to FBFH, FF0H to FFFH immediate data or label FC0H to FFFH immediate data or label
addr addr1 (Mk II mode only) caddr faddr	0000H to 0FFFH immediate data or label (μPD753104) 0000H to 17FFH immediate data or label (μPD753106) 0000H to 1FFFH immediate data or label (μPD753108) 0000H to 0FFFH immediate data or label (μPD753104) 0000H to 17FFH immediate data or label (μPD753106) 0000H to 1FFFH immediate data or label (μPD753108) 12-bit immediate data or label 11-bit immediate data or label
taddr	20H to 7FH immediate data (where bit0 = 0) or label
PORTn IExxx RBn MBn	PORT0 to PORT3, PORT5, PORT6, PORT8, PORT9 IEBT, IET0 to IET2, IE0 to IE2, IE4, IECSI, IEW RB0 to RB3 MB0, MB1, MB15

Note mem can be only used for even address in 8-bit data processing.

(2) Legend in explanation of operation

A:	A register, 4-bit accumulator
B:	B register
C:	C register
D:	D register
E:	E register
H:	H register
L:	L register
X:	X register
XA:	XA register pair; 8-bit accumulator
BC:	BC register pair
DE:	DE register pair
HL:	HL register pair
XA':	XA' expanded register pair
BC':	BC' expanded register pair
DE':	DE' expanded register pair
HL':	HL' expanded register pair
PC:	Program counter
SP:	Stack pointer
CY:	Carry flag, bit accumulator
PSW:	Program status word
MBE:	Memory bank enable flag
RBE:	Register bank enable flag
PORTn:	Port n (n = 0 to 3, 5, 6, 8, 9)
IME:	Interrupt master enable flag
IPS:	Interrupt priority selection register
IE _{xxx} :	Interrupt enable flag
RBS:	Register bank selection register
MBS:	Memory bank selection register
PCC:	Processor clock control register
∴	Separation between address and bit
(xx):	The contents addressed by xx
xxH:	Hexadecimal data

(3) Explanation of symbols under addressing area column

*1	MB = MBE·MBS (MBS = 0, 1, 15)		Data memory addressing
*2	MB = 0		
*3	MBE = 0 : MB = 0 (000H to 07FH) MB = 15 (F80H to FFFH) MBE = 1 : MB = MBS (MBS = 0, 1, 15)		
*4	MB = 15, fmem = FB0H to FBFH, FF0H to FFFH		
*5	MB = 15, pmem = FC0H to FFFH		
*6	μPD753104	addr = 000H to FFFH	Program memory addressing
	μPD753106	addr = 0000H to 17FFH	
	μPD753108	addr = 0000H to 1FFFH	
*7	addr = (Current PC) - 15 to (Current PC) - 1 (Current PC) + 2 to (Current PC) + 16		
	addr1 = (Current PC) - 15 to (Current PC) - 1 (Current PC) + 2 to (Current PC) + 16		
*8	μPD753104	caddr = 000H to FFFH	
	μPD753106	caddr = 0000H to 0FFFH (PC ₁₂ = 0) or 1000H to 17FFH (PC ₁₂ = 1)	
	μPD753108	caddr = 0000H to 0FFFH (PC ₁₂ = 0) or 1000H to 1FFFH (PC ₁₂ = 1)	
*9	faddr = 0000H to 07FFH		
*10	taddr = 0020H to 007FH		
*11	μPD753104	addr1 = 000H to FFFH	
	μPD753106	addr1 = 0000H to 17FFH	
	μPD753108	addr1 = 0000H to 1FFFH	

- Remarks**
1. MB indicates memory bank that can be accessed.
 2. In *2, MB = 0 independently of how MBE and MBS are set.
 3. In *4 and *5, MB = 15 independently of how MBE and MBS are set.
 4. *6 to *11 indicate the areas that can be addressed.

(4) Explanation of number of machine cycles column

S denotes the number of machine cycles required by skip operation when a skip instruction is executed.

The value of S varies as follows.

- When no skip is made: S = 0
- When the skipped instruction is a 1- or 2-byte instruction: S = 1
- When the skipped instruction is a 3-byte instruction^{Note}: S = 2

Note 3-byte instruction: BR !addr, BRA !addr1, CALL !addr or CALLA !addr1 instruction

Caution The GETI instruction is skipped in one machine cycle.

One machine cycle is equal to one cycle of CPU clock Φ (= t_{cy}); time can be selected from among four types by setting PCC.

Instruction Group	Mnemonic	Operand	Number of Bytes	Number of Machine Cycles	Operation	Addressing Area	Skip Condition
Transfer	MOV	A, #n4	1	1	A ← n4		String effect A
		reg1, #n4	2	2	reg1 ← n4		
		XA, #n8	2	2	XA ← n8		String effect A
		HL, #n8	2	2	HL ← n8		String effect B
		rp2, #n8	2	2	rp2 ← n8		
		A, @HL	1	1	A ← (HL)	*1	
		A, @HL+	1	2+S	A ← (HL), then L ← L+1	*1	L = 0
		A, @HL-	1	2+S	A ← (HL), then L ← L-1	*1	L = FH
		A, @rpa1	1	1	A ← (rpa1)	*2	
		XA, @HL	2	2	XA ← (HL)	*1	
		@HL, A	1	1	(HL) ← A	*1	
		@HL, XA	2	2	(HL) ← XA	*1	
		A, mem	2	2	A ← (mem)	*3	
		XA, mem	2	2	XA ← (mem)	*3	
		mem, A	2	2	(mem) ← A	*3	
		mem, XA	2	2	(mem) ← XA	*3	
		A, reg	2	2	A ← reg		
		XA, rp'	2	2	XA ← rp'		
		reg1, A	2	2	reg1 ← A		
		rp'1, XA	2	2	rp'1 ← XA		
	XCH	A, @HL	1	1	A ↔ (HL)	*1	
		A, @HL+	1	2+S	A ↔ (HL), then L ← L+1	*1	L = 0
		A, @HL-	1	2+S	A ↔ (HL), then L ← L-1	*1	L = FH
		A, @rpa1	1	1	A ↔ (rpa1)	*2	
		XA, @HL	2	2	XA ↔ (HL)	*1	
		A, mem	2	2	A ↔ (mem)	*3	
		XA, mem	2	2	XA ↔ (mem)	*3	
		A, reg1	1	1	A ↔ reg1		
XA, rp'		2	2	XA ↔ rp'			

Instruction Group	Mnemonic	Operand	Number of Bytes	Number of Machine Cycles	Operation	Addressing Area	Skip Condition
Table reference	MOVT	XA, @PCDE	1	3	● μPD753104 XA ← (PC ₁₁₋₈ +DE) _{ROM}		
					● μPD753106, 753108 XA ← (PC ₁₂₋₈ +DE) _{ROM}		
		XA, @PCXA	1	3	● μPD753104 XA ← (PC ₁₁₋₈ +XA) _{ROM}		
					● μPD753106, 753108 XA ← (PC ₁₂₋₈ +XA) _{ROM}		
		XA, @BCDE	1	3	XA ← (BCDE) _{ROM} Note	*6	
	XA, @BCXA	1	3	XA ← (BCXA) _{ROM} Note	*6		
Bit transfer	MOV1	CY, fmem.bit	2	2	CY ← (fmem.bit)	*4	
		CY, pmem.@L	2	2	CY ← (pmem ₇₋₂ +L ₃₋₂ .bit(L ₁₋₀))	*5	
		CY, @H+mem.bit	2	2	CY ← (H+mem ₃₋₀ .bit)	*1	
		fmem.bit, CY	2	2	(fmem.bit) ← CY	*4	
		pmem.@L, CY	2	2	(pmem ₇₋₂ +L ₃₋₂ .bit(L ₁₋₀)) ← CY	*5	
		@H+mem.bit, CY	2	2	(H+mem ₃₋₀ .bit) ← CY	*1	
Operation	ADDS	A, #n4	1	1+S	A ← A+n4		carry
		XA, #n8	2	2+S	XA ← XA+n8		carry
		A, @HL	1	1+S	A ← A+(HL)	*1	carry
		XA, rp'	2	2+S	XA ← XA+rp'		carry
		rp'1, XA	2	2+S	rp'1 ← rp'1+XA		carry
	ADDC	A, @HL	1	1	A, CY ← A+(HL)+CY	*1	
		XA, rp'	2	2	XA, CY ← XA+rp'+CY		
		rp'1, XA	2	2	rp'1, CY ← rp'1+XA+CY		
	SUBS	A, @HL	1	1+S	A ← A-(HL)	*1	borrow
		XA, rp'	2	2+S	XA ← XA-rp'		borrow
		rp'1, XA	2	2+S	rp'1 ← rp'1-XA		borrow
	SUBC	A, @HL	1	1	A, CY ← A-(HL)-CY	*1	
		XA, rp'	2	2	XA, CY ← XA-rp'-CY		
		rp'1, XA	2	2	rp'1, CY ← rp'1-XA-CY		

Note Set "0" in B register if the μPD753104 is used. Only low-order one bit of B register will be valid if the μPD753106 or 753108 is used.

Instruction Group	Mnemonic	Operand	Number of Bytes	Number of Machine Cycles	Operation	Addressing Area	Skip Condition
Operation	AND	A, #n4	2	2	$A \leftarrow A \wedge n4$		
		A, @HL	1	1	$A \leftarrow A \wedge (HL)$	*1	
		XA, rp'	2	2	$XA \leftarrow XA \wedge rp'$		
		rp'1, XA	2	2	$rp'1 \leftarrow rp'1 \wedge XA$		
	OR	A, #n4	2	2	$A \leftarrow A \vee n4$		
		A, @HL	1	1	$A \leftarrow A \vee (HL)$	*1	
		XA, rp'	2	2	$XA \leftarrow XA \vee rp'$		
		rp'1, XA	2	2	$rp'1 \leftarrow rp'1 \vee XA$		
	XOR	A, #n4	2	2	$A \leftarrow A \vee n4$		
		A, @HL	1	1	$A \leftarrow A \vee (HL)$	*1	
		XA, rp'	2	2	$XA \leftarrow XA \vee rp'$		
		rp'1, XA	2	2	$rp'1 \leftarrow rp'1 \vee XA$		
Accumulator manipulation	RORC	A	1	1	$CY \leftarrow A_0, A_3 \leftarrow CY, A_{n-1} \leftarrow A_n$		
	NOT	A	2	2	$A \leftarrow \bar{A}$		
Increment and decrement	INCS	reg	1	1+S	$reg \leftarrow reg+1$		reg = 0
		rp1	1	1+S	$rp1 \leftarrow rp1+1$		rp1 = 00H
		@HL	2	2+S	$(HL) \leftarrow (HL)+1$	*1	(HL) = 0
		mem	2	2+S	$(mem) \leftarrow (mem)+1$	*3	(mem) = 0
	DECS	reg	1	1+S	$reg \leftarrow reg-1$		reg = FH
		rp'	2	2+S	$rp' \leftarrow rp'-1$		rp' = FFH
Comparison	SKE	reg, #n4	2	2+S	Skip if reg = n4		reg = n4
		@HL, #n4	2	2+S	Skip if (HL) = n4	*1	(HL) = n4
		A, @HL	1	1+S	Skip if A = (HL)	*1	A = (HL)
		XA, @HL	2	2+S	Skip if XA = (HL)	*1	XA = (HL)
		A, reg	2	2+S	Skip if A = reg		A = reg
		XA, rp'	2	2+S	Skip if XA = rp'		XA = rp'
Carry flag manipulation	SET1	CY	1	1	$CY \leftarrow 1$		
	CLR1	CY	1	1	$CY \leftarrow 0$		
	SKT	CY	1	1+S	Skip if CY = 1		CY = 1
	NOT1	CY	1	1	$CY \leftarrow \bar{CY}$		

Instruction Group	Mnemonic	Operand	Number of Bytes	Number of Machine Cycles	Operation	Addressing Area	Skip Condition
Memory bit manipulation	SET1	mem.bit	2	2	(mem.bit) ← 1	*3	
		fmem.bit	2	2	(fmem.bit) ← 1	*4	
		pmem.@L	2	2	(pmem ₇₋₂ +L ₃₋₂ .bit(L ₁₋₀)) ← 1	*5	
		@H+mem.bit	2	2	(H+mem ₃₋₀ .bit) ← 1	*1	
	CLR1	mem.bit	2	2	(mem.bit) ← 0	*3	
		fmem.bit	2	2	(fmem.bit) ← 0	*4	
		pmem.@L	2	2	(pmem ₇₋₂ +L ₃₋₂ .bit(L ₁₋₀)) ← 0	*5	
		@H+mem.bit	2	2	(H+mem ₃₋₀ .bit) ← 0	*1	
	SKT	mem.bit	2	2+S	Skip if (mem.bit) = 1	*3	(mem.bit) = 1
		fmem.bit	2	2+S	Skip if (fmem.bit) = 1	*4	(fmem.bit) = 1
		pmem.@L	2	2+S	Skip if (pmem ₇₋₂ +L ₃₋₂ .bit(L ₁₋₀)) = 1	*5	(pmem.@L) = 1
		@H+mem.bit	2	2+S	Skip if (H+mem ₃₋₀ .bit) = 1	*1	(@H+mem.bit) = 1
	SKF	mem.bit	2	2+S	Skip if (mem.bit) = 0	*3	(mem.bit) = 0
		fmem.bit	2	2+S	Skip if (fmem.bit) = 0	*4	(fmem.bit) = 0
		pmem.@L	2	2+S	Skip if (pmem ₇₋₂ +L ₃₋₂ .bit(L ₁₋₀)) = 0	*5	(pmem.@L) = 0
		@H+mem.bit	2	2+S	Skip if (H+mem ₃₋₀ .bit) = 0	*1	(@H+mem.bit) = 0
	SKTCLR	fmem.bit	2	2+S	Skip if (fmem.bit) = 1 and clear	*4	(fmem.bit) = 1
		pmem.@L	2	2+S	Skip if (pmem ₇₋₂ +L ₃₋₂ .bit(L ₁₋₀)) = 1 and clear	*5	(pmem.@L) = 1
		@H+mem.bit	2	2+S	Skip if (H+mem ₃₋₀ .bit) = 1 and clear	*1	(@H+mem.bit) = 1
	AND1	CY, fmem.bit	2	2	CY ← CY ∧ (fmem.bit)	*4	
		CY, pmem.@L	2	2	CY ← CY ∧ (pmem ₇₋₂ +L ₃₋₂ .bit(L ₁₋₀))	*5	
		CY, @H+mem.bit	2	2	CY ← CY ∧ (H+mem ₃₋₀ .bit)	*1	
	OR1	CY, fmem.bit	2	2	CY ← CY ∨ (fmem.bit)	*4	
		CY, pmem.@L	2	2	CY ← CY ∨ (pmem ₇₋₂ +L ₃₋₂ .bit(L ₁₋₀))	*5	
CY, @H+mem.bit		2	2	CY ← CY ∨ (H+mem ₃₋₀ .bit)	*1		
XOR1	CY, fmem.bit	2	2	CY ← CY ⊕ (fmem.bit)	*4		
	CY, pmem.@L	2	2	CY ← CY ⊕ (pmem ₇₋₂ +L ₃₋₂ .bit(L ₁₋₀))	*5		
	CY, @H+mem.bit	2	2	CY ← CY ⊕ (H+mem ₃₋₀ .bit)	*1		

Instruction Group	Mnemonic	Operand	Number of Bytes	Number of Machine Cycles	Operation	Addressing Area	Skip Condition
Branch	BR ^{Note}	addr	–	–	<ul style="list-style-type: none"> ● μPD753104 PC₁₁₋₀ ← addr (Select appropriate instruction from among BR !addr, BRCB !caddr and BR \$addr according to the assembler being used.) ● μPD753106, 753108 PC₁₂₋₀ ← addr (Select appropriate instruction from among BR !addr, BRCB !caddr and BR \$addr according to the assembler being used.) 	*6	
		addr1	–	–	<ul style="list-style-type: none"> ● μPD753104 PC₁₁₋₀ ← addr1 (Select appropriate instruction from among BR !addr, BRA !addr1, BRCB !caddr and BR \$addr1 according to the assembler being used.) ● μPD753106, 753108 PC₁₂₋₀ ← addr1 (Select appropriate instruction from among BR !addr, BRA !addr1, BRCB !caddr and BR \$addr1 according to the assembler being used.) 	*11	
		!addr	3	3	<ul style="list-style-type: none"> ● μPD753104 PC₁₁₋₀ ← addr ● μPD753106, 753108 PC₁₂₋₀ ← addr 	*6	
		\$addr	1	2	<ul style="list-style-type: none"> ● μPD753104 PC₁₁₋₀ ← addr ● μPD753106, 753108 PC₁₂₋₀ ← addr 	*7	
		\$addr1	1	2	<ul style="list-style-type: none"> ● μPD753104 PC₁₁₋₀ ← addr1 ● μPD753106, 753108 PC₁₂₋₀ ← addr1 		

Note The above operations in the double boxes can be performed only in the Mk II mode. The other operations can be performed only in the Mk I mode.

Instruction Group	Mnemonic	Operand	Number of Bytes	Number of Machine Cycles	Operation	Addressing Area	Skip Condition	
Branch	BR	PCDE	2	3	● μPD753104 PC ₁₁₋₀ ← PC ₁₁₋₈ +DE			
					● μPD753106, 753108 PC ₁₂₋₀ ← PC ₁₂₋₈ +DE			
	PCXA	2	3	● μPD753104 PC ₁₁₋₀ ← PC ₁₁₋₈ +XA				
				● μPD753106, 753108 PC ₁₂₋₀ ← PC ₁₂₋₈ +XA				
	BCDE	2	3	● μPD753104 PC ₁₁₋₀ ← BCDE ^{Note 1}	*6			
				● μPD753106, 753108 PC ₁₂₋₀ ← BCDE ^{Note 2}				
	BCXA	2	3	● μPD753104 PC ₁₁₋₀ ← BCXA ^{Note 1}	*6			
				● μPD753106, 753108 PC ₁₂₋₀ ← BCXA ^{Note 2}				
	BRA ^{Note 3}		!addr1	3	3	● μPD753104 PC ₁₁₋₀ ← addr1	*11	
						● μPD753106, 753108 PC ₁₂₋₀ ← addr1		
BRCB	!caddr		2	2	● μPD753104 PC ₁₁₋₀ ← caddr ₁₁₋₀	*8		
					● μPD753106, 753108 PC ₁₂₋₀ ← PC ₁₂ +caddr ₁₁₋₀			
Subroutine stack control	CALLA ^{Note 3} !addr1		3	3	● μPD753104 (SP-2) ← x, x, MBE, RBE (SP-6) (SP-3) (SP-4) ← PC ₁₁₋₀ (SP-5) ← 0, 0, 0 PC ₁₁₋₀ ← addr1, SP ← SP-6	*11		
					● μPD753106, 753108 (SP-2) ← x, x, MBE, RBE (SP-6) (SP-3) (SP-4) ← PC ₁₁₋₀ (SP-5) ← 0, 0, 0, PC ₁₂ PC ₁₂₋₀ ← addr1, SP ← SP-6			

- Notes**
1. "0" must be set to B register.
 2. Only low-order one bit is valid in B register.
 3. The above operations in the double boxes can be performed only in the Mk II mode. The other operations can be performed only in the Mk I mode.

Instruction Group	Mnemonic	Operand	Number of Bytes	Number of Machine Cycles	Operation	Addressing Area	Skip Condition
Subroutine stack control	CALL ^{Note}	!addr	3	3	<ul style="list-style-type: none"> ● μPD753104 (SP-3) ← MBE, RBE, 0, 0 (SP-4) (SP-1) (SP-2) ← PC₁₁₋₀ PC₁₁₋₀ ← addr, SP ← SP-4 	*6	
					<ul style="list-style-type: none"> ● μPD753106, 753108 (SP-3) ← MBE, RBE, 0, PC₁₂ (SP-4) (SP-1) (SP-2) ← PC₁₁₋₀ PC₁₂₋₀ ← addr, SP ← SP-4 		
				4	<ul style="list-style-type: none"> ● μPD753104 (SP-2) ← x, x, MBE, RBE (SP-6) (SP-3) (SP-4) ← PC₁₁₋₀ (SP-5) ← 0, 0, 0, 0 PC₁₁₋₀ ← addr, SP ← SP-6 		
					<ul style="list-style-type: none"> ● μPD753106, 753108 (SP-2) ← x, x, MBE, RBE (SP-6) (SP-3) (SP-4) ← PC₁₁₋₀ (SP-5) ← 0, 0, 0, PC₁₂ PC₁₂₋₀ ← addr, SP ← SP-6 		
	CALLF ^{Note}	!faddr	2	2	<ul style="list-style-type: none"> ● μPD753104 (SP-3) ← MBE, RBE, 0, 0 (SP-4) (SP-1) (SP-2) ← PC₁₁₋₀ PC₁₁₋₀ ← 0+faddr, SP ← SP-4 	*9	
					<ul style="list-style-type: none"> ● μPD753106, 753108 (SP-3) ← MBE, RBE, 0, PC₁₂ (SP-4) (SP-1) (SP-2) ← PC₁₁₋₀ PC₁₂₋₀ ← 00+faddr, SP ← SP-4 		
				3	<ul style="list-style-type: none"> ● μPD753104 (SP-2) ← x, x, MBE, RBE (SP-6) (SP-3) (SP-4) ← PC₁₁₋₀ (SP-5) ← 0, 0, 0, 0 PC₁₁₋₀ ← 0+faddr, SP ← SP-6 		
					<ul style="list-style-type: none"> ● μPD753106, 753108 (SP-2) ← x, x, MBE, RBE (SP-6) (SP-3) (SP-4) ← PC₁₁₋₀ (SP-5) ← 0, 0, 0, PC₁₂ PC₁₂₋₀ ← 00+faddr, SP ← SP-6 		

Note The above operations in the double boxes can be performed only in the Mk II mode. The other operations can be performed only in the Mk I mode.

Instruction Group	Mnemonic	Operand	Number of Bytes	Number of Machine Cycles	Operation	Addressing Area	Skip Condition
Subroutine stack control	RET ^{Note}		1	3	<ul style="list-style-type: none"> ● μPD753104 PC₁₁₋₀ ← (SP) (SP+3) (SP+2) MBE, RBE, 0, 0 ← (SP+1), SP ← SP+4 ● μPD753106, 753108 PC₁₁₋₀ ← (SP) (SP+3) (SP+2) MBE, RBE, 0, PC₁₂ ← (SP+1), SP ← SP+4 ● μPD753104 x, x, MBE, RBE ← (SP+4) 0, 0, 0, 0 ← (SP+1) PC₁₁₋₀ ← (SP) (SP+3) (SP+2), SP ← SP+6 ● μPD753106, 753108 x, x, MBE, RBE ← (SP+4) MBE, 0, 0, PC₁₂ ← (SP+1) PC₁₁₋₀ ← (SP) (SP+3) (SP+2), SP ← SP+6 		
	RETS ^{Note}		1	3+S	<ul style="list-style-type: none"> ● μPD753104 MBE, RBE, 0, 0 ← (SP+1) PC₁₁₋₀ ← (SP) (SP+3) (SP+2) SP ← SP+4 then skip unconditionally ● μPD753106, 753108 MBE, RBE, 0, PC₁₂ ← (SP+1) PC₁₁₋₀ ← (SP) (SP+3) (SP+2) SP ← SP+4 then skip unconditionally ● μPD753104 0, 0, 0, 0 ← (SP+1) PC₁₁₋₀ ← (SP) (SP+3) (SP+2) x, x, MBE, RBE ← (SP+4) SP ← SP+6 then skip unconditionally ● μPD753106, 753108 0, 0, 0, PC₁₂ ← (SP+1) PC₁₁₋₀ ← (SP) (SP+3) (SP+2) x, x, MBE, RBE ← (SP+4) SP ← SP+4 then skip unconditionally 		Unconditional

Note The above operations in the double boxes can be performed only in the Mk II mode. The other operations can be performed only in the Mk I mode.

Instruction Group	Mnemonic	Operand	Number of Bytes	Number of Machine Cycles	Operation	Addressing Area	Skip Condition
Subroutine stack control	RET ^{Note 1}		1	3	<ul style="list-style-type: none"> ● μPD753104 MBE, RBE, 0, 0 ← (SP+1) PC₁₁₋₀ ← (SP) (SP+3) (SP+2) PSW ← (SP+4) (SP+5), SP ← SP+6 ● μPD753106, 753108 MBE, RBE, 0, PC₁₂ ← (SP+1) PC₁₁₋₀ ← (SP) (SP+3) (SP+2) PSW ← (SP+4) (SP+5), SP ← SP+6 ● μPD753104 0, 0, 0, 0 ← (SP+1) PC₁₁₋₀ ← (SP) (SP+3) (SP+2) PSW ← (SP+4) (SP+5), SP ← SP+6 ● μPD753106, 753108 0, 0, 0, PC₁₂ ← (SP+1) PC₁₁₋₀ ← (SP) (SP+3) (SP+2) PSW ← (SP+4) (SP+5), SP ← SP+6 		
	PUSH	rp	1	1	(SP-1) (SP-2) ← rp, SP ← SP-2		
		BS	2	2	(SP-1) ← MBS, (SP-2) ← RBS, SP ← SP-2		
	POP	rp	1	1	rp ← (SP+1) (SP), SP ← SP+2		
		BS	2	2	MBS ← (SP+1), RBS ← (SP), SP ← SP+2		
	Interrupt control	EI		2	2	IME (IPS.3) ← 1	
IE _{xxx}			2	2	IE _{xxx} ← 1		
DI			2	2	IME (IPS.3) ← 0		
		IE _{xxx}	2	2	IE _{xxx} ← 0		
Input/output	IN ^{Note 2}	A, PORT _n	2	2	A ← PORT _n (n = 0 to 3, 5, 6, 8, 9)		
		XA, PORT _n	2	2	XA ← PORT _{n+1} , PORT _n (n = 8)		
	OUT ^{Note 2}	PORT _n , A	2	2	PORT _n ← A (n = 3, 5, 6, 8, 9)		
		PORT _n , XA	2	2	PORT _{n+1} , PORT _n ← XA (n = 8)		
CPU control	HALT		2	2	Set HALT Mode (PCC.2 ← 1)		
	STOP		2	2	Set STOP Mode (PCC.3 ← 1)		
	NOP		1	1	No Operation		
Special	SEL	RB _n	2	2	RBS ← n (n = 0 to 3)		
		MB _n	2	2	MBS ← n (n = 0, 1, 15)		

Notes 1. The above operations in the double boxes can be performed only in the Mk II mode. The other operations can be performed only in the Mk I mode.

2. While the IN instruction and OUT instruction are being executed, the MBE must be set to 0 or 1, and MBS must be set to 15.

Instruction Group	Mnemonic	Operand	Number of Bytes	Number of Machine Cycles	Operation	Addressing Area	Skip Condition
Special	GETI ^{Note 1, 2}	taddr	1	3	<ul style="list-style-type: none"> • μPD753104 • When TBR instruction PC₁₁₋₀ ← (taddr)₃₋₀ + (taddr+1) 	*10	
					<ul style="list-style-type: none"> • When TCALL instruction (SP-4) (SP-1) (SP-2) ← PC₁₁₋₀ (SP-3) ← MBE, RBE, 0, 0 PC₁₁₋₀ ← (taddr)₃₋₀ + (taddr+1) SP ← SP-4 		
					<ul style="list-style-type: none"> • When instruction other than TBR and TCALL instructions (taddr) (taddr+1) instruction is executed. 		Depending on the reference instruction
					<ul style="list-style-type: none"> • μPD753106, 753108 • When TBR instruction PC₁₂₋₀ ← (taddr)₄₋₀ + (taddr+1) 		
					<ul style="list-style-type: none"> • When TCALL instruction (SP-4) (SP-1) (SP-2) ← PC₁₁₋₀ (SP-3) ← MBE, RBE, 0, PC₁₂ PC₁₂₋₀ ← (taddr)₄₋₀ + (taddr+1) SP ← SP-4 		
					<ul style="list-style-type: none"> • When instruction other than TBR and TCALL instructions (taddr) (taddr+1) instruction is executed. 		Depending on the reference instruction
				3	<ul style="list-style-type: none"> • μPD753104 • When TBR instruction PC₁₁₋₀ ← (taddr)₃₋₀ + (taddr+1) 	*10	
					<ul style="list-style-type: none"> • When TCALL instruction (SP-6) (SP-3) (SP-4) ← PC₁₁₋₀ (SP-5) ← 0, 0, 0, 0 (SP-2) ← x, x, MBE, RBE PC₁₁₋₀ ← (taddr)₃₋₀ + (taddr+1) SP ← SP-6 		
					<ul style="list-style-type: none"> • When instruction other than TBR and TCALL instructions (taddr) (taddr+1) instruction is executed. 		Depending on the reference instruction
					<ul style="list-style-type: none"> • μPD753106, 753108 • When TBR instruction PC₁₂₋₀ ← (taddr)₄₋₀ + (taddr+1) 		
					<ul style="list-style-type: none"> • When TCALL instruction (SP-6) (SP-3) (SP-4) ← PC₁₁₋₀ (SP-5) ← 0, 0, 0, PC₁₂ (SP-2) ← x, x, MBE, RBE PC₁₂₋₀ ← (taddr)₄₋₀ + (taddr+1) SP ← SP-6 		
					<ul style="list-style-type: none"> • When instruction other than TBR and TCALL instructions (taddr) (taddr+1) instruction is executed. 		Depending on the reference instruction

Notes 1. The TBR and TCALL instructions are the table definition assembler pseudo instructions of the GETI instruction.

2. The above operations in the double boxes can be performed only in the Mk II mode. The other operations can be performed only in the Mk I mode.

12. ELECTRICAL SPECIFICATIONS

ABSOLUTE MAXIMUM RATINGS (T_A = 25°C)

Parameter	Symbol	Test Conditions	Rating	Unit	
Supply voltage	V _{DD}		-0.3 to +7.0	V	
Input voltage	V _{I1}	Except port 5	-0.3 to V _{DD} + 0.3	V	
	V _{I2}	Port 5	On-chip pull-up resistor	-0.3 to V _{DD} + 0.3	V
			When N-ch open-drain	-0.3 to +14	V
Output voltage	V _O		-0.3 to V _{DD} + 0.3	V	
Output current, high	I _{OH}	Per pin	-10	mA	
		Total of all pins	-30	mA	
Output current, low	I _{OL}	Per pin	30	mA	
		Total of all pins	220	mA	
Operating ambient temperature	T _A		-40 to +85 ^{Note}	°C	
Storage temperature	T _{stg}		-65 to +150	°C	

Note When LCD is driven in normal mode: T_A = -10 to +85°C

Caution Product quality may suffer if the absolute maximum rating is exceeded even momentarily for any parameter. That is, the absolute maximum ratings are rated values at which the product is on the verge of suffering physical damage, and therefore the product must be used under conditions that ensure that the absolute maximum ratings are not exceeded.

CAPACITANCE (T_A = 25°C, V_{DD} = 0 V)

Parameter	Symbol	Test Conditions	MIN.	TYP.	MAX.	Unit
Input capacitance	C _{IN}	f = 1 MHz			15	pF
Output capacitance	C _{OUT}	Unmeasured pins returned to 0 V.			15	pF
I/O capacitance	C _{IO}				15	pF

MAIN SYSTEM CLOCK OSCILLATOR CHARACTERISTICS (T_A = -40 to +85°C, V_{DD} = 1.8 to 5.5 V)

Resonator	Recommended Constant	Parameter	Test Conditions	MIN.	TYP.	MAX.	Unit
Ceramic resonator		Oscillation frequency (f _x) ^{Note 1}		1.0		6.0 ^{Note 2}	MHz
		Oscillation stabilization time ^{Note 3}	After V _{DD} reaches oscillation voltage range MIN.			4	ms
Crystal resonator		Oscillation frequency (f _x) ^{Note 1}		1.0		6.0 ^{Note 2}	MHz
		Oscillation stabilization time ^{Note 3}	V _{DD} = 4.5 to 5.5 V			10 30	ms
External clock		X1 input frequency (f _x) ^{Note 1}		1.0		6.0 ^{Note 2}	MHz
		X1 input high/low-level width (t _{xH} , t _{xL})		83.3		500	ns

- Notes 1.** The oscillation frequency and X1 input frequency indicate only oscillator characteristics. Refer to the AC Characteristics for instruction execution time.
- When the oscillation frequency is 4.19 MHz < f_x ≤ 6.0 MHz at 1.8 V ≤ V_{DD} < 2.7 V, setting the processor clock control register (PCC) to 0011 results in 1 machine cycle time being less than the required 0.95 μs. Therefore, set PCC to a value other than 0011.
 - The oscillation stabilization time is necessary for oscillation to stabilize after applying V_{DD} or releasing the STOP mode.

Caution When using the main system clock oscillator, wire as follows in the area enclosed by the broken lines in the above figures to avoid an adverse effect from wiring capacitance.

- Keep the wiring length as short as possible.
- Do not cross the wiring with other signal lines.
- Do not route the wiring near a signal line through which a high fluctuating current flows.
- Always make the ground point of the oscillator capacitor the same potential as V_{ss}.
- Do not ground the capacitor to a ground pattern through which a high current flows.
- Do not fetch signals from the oscillator.

SUBSYSTEM CLOCK OSCILLATOR CHARACTERISTICS (T_A = -40 to +85°C, V_{DD} = 1.8 to 5.5 V)

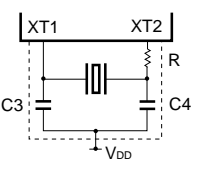
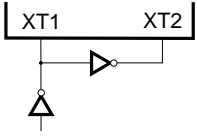
Resonator	Recommended Constant	Parameter	Test Conditions	MIN.	TYP.	MAX.	Unit
Crystal resonator		Oscillation frequency (f _{XT}) ^{Note 1}		32	32.768	35	kHz
		Oscillation stabilization time ^{Note 2}	V _{DD} = 4.5 to 5.5 V		1.0	2	s
External clock		XT1 input frequency (f _{XT}) ^{Note 1}		32		100	kHz
		X1 input high/low-level width (t _{XTH} , t _{XTL})		5		15	μs

- Notes**
1. Indicates only oscillator characteristics. Refer to AC Characteristics for instruction execution time.
 2. The oscillation stabilization time is necessary for oscillation to stabilize after applying V_{DD}.

Caution When using the subsystem clock oscillator, wire as follows in the area enclosed by the broken lines in the above figures to avoid an adverse effect from wiring capacitance.

- Keep the wiring length as short as possible.
- Do not cross the wiring with other signal lines.
- Do not route the wiring near a signal line through which a high fluctuating current flows.
- Always make the ground point of the oscillator capacitor the same potential as V_{SS}.
- Do not ground the capacitor to a ground pattern through which a high current flows.
- Do not fetch signals from the oscillator.

The subsystem clock oscillator is designed as a low-amplification circuit for reducing current consumption, and is more prone to malfunction due to noise than the main system clock oscillator. Particular care is therefore required with the wiring method when the subsystem clock is used.

RECOMMENDED OSCILLATOR CONSTANT

Ceramic Resonator (T_A = -20 to +85°C)

Manufacturer	Product Name	Frequency (MHz)	Oscillator Constant (pF)		Oscillation Voltage Range (V _{DD})		Remarks
			C1	C2	MIN.	MAX.	
Kyocera Corporation	KBR-1000F/Y	1.0	100	100	1.8	5.5	—
	KBR-2.0MS	2.0	82	82	2.2		
	KBR-4.19MSA	4.19	33	33	1.8		On-chip capacitor product
	KBR-4.19MKS		—	—			
	PBRC 4.19A		33	33			
	PBRC 4.19B		—	—			
	KBR-6.0MSA	6.0	33	33			On-chip capacitor product
	KBR-6.0MKS		—	—			
	PBRC 6.00A		33	33			
	PBRC 6.00B		—	—			

Ceramic Resonator (T_A = -40 to +85°C)

Manufacturer	Product Name	Frequency (MHz)	Oscillator Constant (pF)		Oscillation Voltage Range (V _{DD})		Remarks
			C1	C2	MIN.	MAX.	
TDK	CCR1000K2	1.0	150	150	2.3	5.5	—
	CCR2.0MC33	2.0	—	—	2.0		
	FCR4.19MC5	4.19					
	CCR4.19MC3						
	FCR6.0MC5	6.0			2.2		
	CCR6.0MC3						

Caution The oscillator constant and oscillation voltage range indicate conditions of stable oscillation. Oscillation frequency precision is not guaranteed. For applications requiring oscillation frequency precision, the oscillation frequency must be adjusted on the implementation circuit. For details, please contact directly the manufacturer of the resonator you will use.

Ceramic Resonator (T_A = -20 to +80°C)

Manufacturer	Product Name	Frequency (MHz)	Oscillator Constant (pF)		Oscillation Voltage Range (V _{DD})		Remarks
			C1	C2	MIN.	MAX.	
Murata Mfg. Co., Ltd.	CSB1000J	1.0	100	100	2.4	5.5	R _d = 5.6 kΩ ^{Note}
	CSA2.00MG	2.0	30	30	1.8		—
	CST2.00MGW		—	—			On-chip capacitor product
	CSA3.00MG	3.0	30	30			—
	CST3.00MGW		—	—			On-chip capacitor product
	CSA4.19MG	4.19	30	30			—
	CST4.19MGW		—	—			On-chip capacitor product
	CSA5.00MG	5.0	30	30	2.2		—
	CSA5.00MGU				1.8		
	CST5.00MGW		—	—	2.2	On-chip capacitor product	
	CST5.00MGWU		—	—	1.8		
	CSA6.00MG	6.0	30	30	2.5		—
	CSA6.00MGU				1.8		
	CST6.00MGW		—	—	2.5	On-chip capacitor product	
CST6.00MGWU	—		—	1.8			

Note If using the CSB1000J (1.0 MHz) ceramic resonator manufactured by Murata Mfg. Co., Ltd., a limiting resistor (R_d = 5.6 kΩ) is required (see figure below). A limiting resistor is not required if using the other recommended resonators.

Recommended Main System Clock Circuit Example (using Murata Mfg. Co., Ltd. CSB1000J)

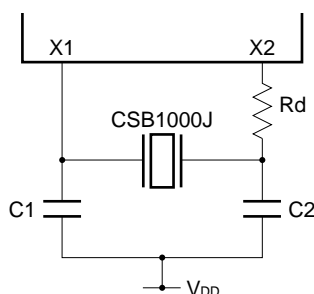

Caution The oscillator constant and oscillation voltage range indicate conditions of stable oscillation. Oscillation frequency precision is not guaranteed. For applications requiring oscillation frequency precision, the oscillation frequency must be adjusted on the implementation circuit. For details, please contact directly the manufacturer of the resonator you will use.

Crystal Resonator

Manufacturer	Product Name	Frequency (MHz)	Oscillator Constant (pF)		Oscillation Voltage Range (V _{DD})		Remarks	
			C1	C2	MIN.	MAX.		
Kinseki	HC-49/U	2.0	15	15	1.8	5.5	T _A = -20 to +70°C	
		4.19						
		6.0			2.5	5.5		
	HC-49/U-S	4.19			1.8	5.5		T _A = -10 to +70°C
		6.0			2.5	5.5		

Caution The oscillator constant and oscillation voltage range indicate conditions of stable oscillation. Oscillation frequency precision is not guaranteed. For applications requiring oscillation frequency precision, the oscillation frequency must be adjusted on the implementation circuit. For details, please contact directly the manufacturer of the resonator you will use.

DC CHARACTERISTICS (T_A = -40 to +85°C, V_{DD} = 1.8 to 5.5 V)

Parameter	Symbol	Test Conditions		MIN.	TYP.	MAX.	Unit	
Output current, low	I _{OL}	Per pin				15	mA	
		Total of all pins				150	mA	
Input voltage, high	V _{IH1}	Ports 2, 3, 8, 9		2.7 ≤ V _{DD} ≤ 5.5 V	0.7V _{DD}	V _{DD}	V	
				1.8 ≤ V _{DD} < 2.7 V	0.9V _{DD}	V _{DD}	V	
	V _{IH2}	Ports 0, 1, 6, $\overline{\text{RESET}}$		2.7 ≤ V _{DD} ≤ 5.5 V	0.8V _{DD}	V _{DD}	V	
				1.8 ≤ V _{DD} < 2.7 V	0.9V _{DD}	V _{DD}	V	
	V _{IH3}	Port 5	On-chip pull-up resistor	2.7 ≤ V _{DD} ≤ 5.5 V	0.7V _{DD}	V _{DD}	V	
				1.8 ≤ V _{DD} < 2.7 V	0.9V _{DD}	V _{DD}	V	
			When N-ch open-drain	2.7 ≤ V _{DD} ≤ 5.5 V	0.7V _{DD}	13	V	
				1.8 ≤ V _{DD} < 2.7 V	0.9V _{DD}	13	V	
V _{IH4}	X1, XT1		V _{DD} -0.1		V _{DD}	V		
Input voltage, low	V _{IL1}	Ports 2, 3, 5, 8, 9		2.7 ≤ V _{DD} ≤ 5.5 V	0	0.3V _{DD}	V	
				1.8 ≤ V _{DD} < 2.7 V	0	0.1V _{DD}	V	
	V _{IL2}	Ports 0, 1, 6, $\overline{\text{RESET}}$		2.7 ≤ V _{DD} ≤ 5.5 V	0	0.2V _{DD}	V	
				1.8 ≤ V _{DD} < 2.7 V	0	0.1V _{DD}	V	
	V _{IL3}	X1, XT1		0		0.1	V	
Output voltage, high	V _{OH}	$\overline{\text{SCK}}$, SO, ports 2, 3, 6, 8, 9 I _{OH} = -1.0 mA		V _{DD} -0.5			V	
Output voltage, low	V _{OL1}	$\overline{\text{SCK}}$, SO, ports 2, 3, 5, 6, 8, 9		I _{OL} = 15 mA, V _{DD} = 4.5 to 5.5 V	0.2	2.0	V	
				I _{OL} = 1.6 mA			0.4	V
	V _{OL2}	SB0, SB1	N-ch open-drain pull-up resistor ≥ 1 kΩ				0.2V _{DD}	V
Input leakage current, high	I _{LIH1}	V _{IN} = V _{DD}	Pins other than X1, XT1			3	μA	
	I _{LIH2}		X1, XT1			20	μA	
	I _{LIH3}	V _{IN} = 13 V	Port 5 (When N-ch open-drain)			20	μA	
Input leakage current, low	I _{LIL1}	V _{IN} = 0 V	Pins other than X1, XT1, port 5			-3	μA	
	I _{LIL2}		X1, XT1			-20	μA	
	I _{LIL3}		Port 5 (When N-ch open-drain) When input instruction is not executed				-3	μA
			Port 5 (When N-ch open-drain) When input instruction is executed	V _{DD} = 5.0 V			-10	-27
	V _{DD} = 3.0 V					-3	-8	μA
Output leakage current, high	I _{LOH1}	V _{OUT} = V _{DD}	$\overline{\text{SCK}}$, SO/SB0, SB1, ports 2, 3, 6, 8, 9, port 5 (When N-ch open-drain)			3	μA	
	I _{LOH2}	V _{OUT} = 13 V	Port 5 (When N-ch open-drain)			20	μA	
Output leakage current, low	I _{LOL}	V _{OUT} = 0 V				-3	μA	
On-chip pull-up resistor	R _{L1}	V _{IN} = 0 V	Ports 0 to 3, 6, 8, 9 (Excluding P00 pin)		50	100	200	kΩ
	R _{L2}		Port 5 (When mask option is selected)		15	30	60	kΩ

★

DC CHARACTERISTICS (T_A = -40 to +85°C, V_{DD} = 1.8 to 5.5 V)

Parameter	Symbol	Test Conditions		MIN.	TYP.	MAX.	Unit	
LCD drive voltage	V _{LCD}	VAC0 = 0	TA = -40 to +85°C	2.7		V _{DD}	V	
			TA = -10 to +85°C	2.2		V _{DD}	V	
		VAC0 = 1		1.8		V _{DD}	V	
VAC current ^{Note 1}	I _{VAC}	VAC0 = 1, V _{DD} = 2.0 V ±10%			1	4	μA	
LCD split resistor ^{Note 2}	R _{LCD1}			50	100	200	kΩ	
	R _{LCD2}			5	10	20	kΩ	
LCD output voltage deviation ^{Note 3} (common)	V _{ODC}	I _o = ±1.0 μA	V _{LCD0} = V _{LCD} V _{LCD1} = V _{LCD} × 2/3 V _{LCD2} = V _{LCD} × 1/3 1.8 V ≤ V _{LCD} ≤ V _{DD}	0		±0.2	V	
		I _o = ±5.0 μA	V _{LCD0} = V _{LCD} V _{LCD1} = V _{LCD} × 2/3 V _{LCD2} = V _{LCD} × 1/3 2.2 V ≤ V _{LCD} ≤ V _{DD}	0		±0.2	V	
LCD output voltage deviation ^{Note 3} (segment)	V _{ODS}	I _o = ±0.5 μA	V _{LCD0} = V _{LCD} V _{LCD1} = V _{LCD} × 2/3 V _{LCD2} = V _{LCD} × 1/3 1.8 V ≤ V _{LCD} ≤ V _{DD}	0		±0.2	V	
		I _o = ±1.0 μA	V _{LCD0} = V _{LCD} V _{LCD1} = V _{LCD} × 2/3 V _{LCD2} = V _{LCD} × 1/3 2.2 V ≤ V _{LCD} ≤ V _{DD}	0		±0.2	V	
Supply current ^{Note 4}	I _{DD1}	6.0 MHz ^{Note 5} Crystal oscillation	V _{DD} = 5.0 V ±10% ^{Note 6}		1.9	6.0	mA	
			V _{DD} = 3.0 V ±10% ^{Note 7}		0.4	1.3	mA	
	I _{DD2}	C1 = C2 = 22 pF	HALT mode	V _{DD} = 5.0 V ±10%		0.72	2.1	mA
				V _{DD} = 3.0 V ±10%		0.27	0.8	mA
	I _{DD1}	4.19 MHz ^{Note 5} Crystal oscillation	V _{DD} = 5.0 V ±10% ^{Note 6}		1.5	4.0	mA	
			V _{DD} = 3.0 V ±10% ^{Note 7}		0.25	0.75	mA	
	I _{DD2}	C1 = C2 = 22 pF	HALT mode	V _{DD} = 5.0 V ±10%		0.7	2.0	mA
				V _{DD} = 3.0 V ±10%		0.23	0.7	mA
	I _{DD3}	32.768 kHz ^{Note 8} Crystal oscillation	Low-voltage mode ^{Note 9}	V _{DD} = 3.0 V ±10%		12	35.0	μA
				V _{DD} = 2.0 V ±10%		4.5	12.0	μA
				V _{DD} = 3.0 V, T _A = 25°C		12	24.0	μA
			Low current consumption mode ^{Note 10}	V _{DD} = 3.0 V ±10%		6.0	18.0	μA
				V _{DD} = 3.0 V, T _A = 25°C		6.0	12.0	μA
	I _{DD4}	HALT mode	Low-voltage mode ^{Note 9}	V _{DD} = 3.0 V ±10%		8.5	25	μA
				V _{DD} = 2.0 V ±10%		3.0	9.0	μA
Low current consumption mode ^{Note 10}			V _{DD} = 3.0 V, T _A = 25°C		8.5	17	μA	
			V _{DD} = 3.0 V ±10%		3.5	12	μA	
I _{DD5}	XT1 = 0 V ^{Note 11} STOP mode	V _{DD} = 5.0 V ±10%			0.05	10	μA	
			V _{DD} = 3.0 V		0.02	5.0	μA	
		±10%	T _A = 25°C		0.02	3.0	μA	

- Notes**
1. Clear VAC0 to 0 in the low current consumption mode and STOP mode. When VAC0 is set to 1, the current increases by about 1 μA .
 2. Either R_{LCD1} or R_{LCD2} can be selected by the mask option.
 3. The voltage deviation is the difference from the output voltage corresponding to the ideal value of the segment and common outputs ($V_{\text{LCD}n}$; n = 0, 1, 2).
 4. Not including currents flowing in on-chip pull-up resistors or LCD split resistors.
 5. Including oscillation of the subsystem clock.
 6. When the processor clock control register (PCC) is set to 0011 and the device is operated in the high-speed mode.
 7. When PCC is set to 0000 and the device is operated in the low-speed mode.
 8. When the system clock control register (SCC) is set to 1001 and the device is operated on the subsystem clock, with main system clock oscillation stopped.
 9. When the sub-oscillator control register (SOS) is set to 0000.
 10. When the SOS is set to 0010.
 11. When the SOS is set to 00×1, and the sub-oscillator feedback resistor is not used (× : don't care).

AC CHARACTERISTICS (T_A = -40 to +85°C, V_{DD} = 1.8 to 5.5 V)

Parameter	Symbol	Test Conditions		MIN.	TYP.	MAX.	Unit
CPU clock cycle time ^{Note 1} (minimum instruction execution time = 1 machine cycle)	t _{cy}	Operating on main system clock	V _{DD} = 2.7 to 5.5 V	0.67		64	μs
				0.95		64	μs
		Operating on subsystem clock		114	122	125	μs
T10, T11, T12 input frequency	f _{TI}	V _{DD} = 2.7 to 5.5 V		0		1.0	MHz
				0		275	kHz
T10, T11, T12 input high/low-level width	t _{TIH} , t _{TIL}	V _{DD} = 2.7 to 5.5 V		0.48			μs
				1.8			μs
Interrupt input high/low-level width	t _{INTH} , t _{INTL}	INT0	IM02 = 0	Note 2			μs
			IM02 = 1	10			μs
		INT1, 2, 4		10			μs
		KR0-KR3		10			μs
RESET low-level width	t _{RSL}			10			μs

- Notes 1.** The cycle time (minimum instruction execution time) of the CPU clock (Φ) is determined by the oscillation frequency of the connected resonator (and external clock), the system clock control register (SCC) and the processor clock control register (PCC). The figure at the right indicates the cycle time t_{cy} versus supply voltage V_{DD} characteristic with the main system clock operating.
- 2.** 2t_{cy} or 128/f_x is set by setting the interrupt mode register (IM0).

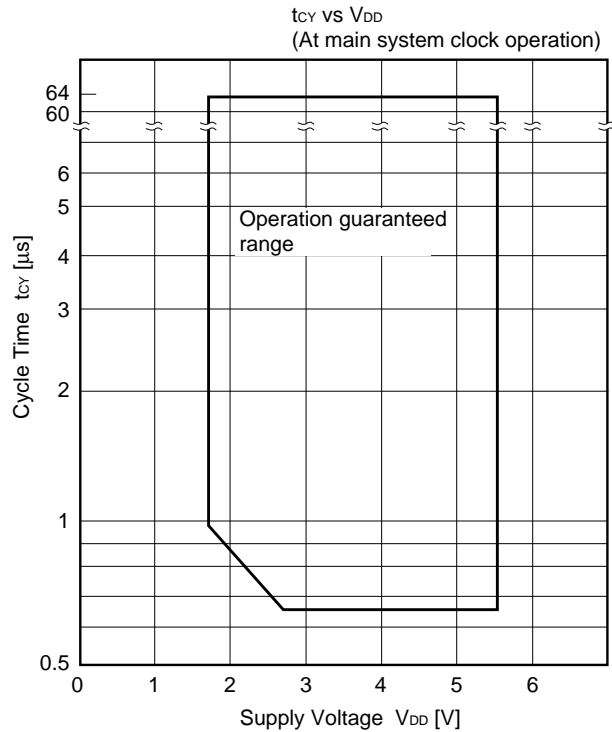

SERIAL TRANSFER OPERATION

2-Wire and 3-Wire Serial I/O Modes ($\overline{\text{SCK}}$...Internal Clock Output): ($T_A = -40$ to $+85^\circ\text{C}$, $V_{DD} = 1.8$ to 5.5 V)

Parameter	Symbol	Test Conditions	MIN.	TYP.	MAX.	Unit
$\overline{\text{SCK}}$ cycle time	t_{KCY1}	$V_{DD} = 2.7$ to 5.5 V	1300			ns
			3800			ns
$\overline{\text{SCK}}$ high/low-level width	$t_{\text{KL1}}, t_{\text{KH1}}$	$V_{DD} = 2.7$ to 5.5 V	$t_{\text{KCY1}}/2-50$			ns
			$t_{\text{KCY1}}/2-150$			ns
SI ^{Note 1} setup time (to $\overline{\text{SCK}}\uparrow$)	t_{SIK1}	$V_{DD} = 2.7$ to 5.5 V	150			ns
			500			ns
SI ^{Note 1} hold time (from $\overline{\text{SCK}}\uparrow$)	t_{KSI1}	$V_{DD} = 2.7$ to 5.5 V	400			ns
			600			ns
Delay time from $\overline{\text{SCK}}\downarrow$ to SO ^{Note 1} output	t_{KSO1}	$R_L = 1$ k Ω , $C_L = 100$ pF	$V_{DD} = 2.7$ to 5.5 V		250	ns
				Note 2		1000

- Notes**
1. Read as SB0 or SB1 when using the 2-wire serial I/O mode.
 2. R_L and C_L are the load resistance and load capacitance of the SO output line.

2-Wire and 3-Wire Serial I/O Modes ($\overline{\text{SCK}}$...External Clock Input): ($T_A = -40$ to $+85^\circ\text{C}$, $V_{DD} = 1.8$ to 5.5 V)

Parameter	Symbol	Test Conditions	MIN.	TYP.	MAX.	Unit
$\overline{\text{SCK}}$ cycle time	t_{KCY2}	$V_{DD} = 2.7$ to 5.5 V	800			ns
			3200			ns
$\overline{\text{SCK}}$ high/low-level width	$t_{\text{KL2}}, t_{\text{KH2}}$	$V_{DD} = 2.7$ to 5.5 V	400			ns
			1600			ns
SI ^{Note 1} setup time (to $\overline{\text{SCK}}\uparrow$)	t_{SIK2}	$V_{DD} = 2.7$ to 5.5 V	100			ns
			150			ns
SI ^{Note 1} hold time (from $\overline{\text{SCK}}\uparrow$)	t_{KSI2}	$V_{DD} = 2.7$ to 5.5 V	400			ns
			600			ns
Delay time from $\overline{\text{SCK}}\downarrow$ to SO ^{Note 1} output	t_{KSO2}	$R_L = 1$ k Ω , $C_L = 100$ pF	$V_{DD} = 2.7$ to 5.5 V		300	ns
				Note 2		1000

- Notes**
1. Read as SB0 or SB1 when using the 2-wire serial I/O mode.
 2. R_L and C_L are the load resistance and load capacitance of the SO output line.

SBI Mode ($\overline{\text{SCK}}$...Internal Clock Output (Master)): ($T_A = -40$ to $+85^\circ\text{C}$, $V_{DD} = 1.8$ to 5.5 V)

Parameter	Symbol	Test Conditions	MIN.	TYP.	MAX.	Unit		
$\overline{\text{SCK}}$ cycle time	t_{KCY3}	$V_{DD} = 2.7$ to 5.5 V	1300			ns		
			3800			ns		
$\overline{\text{SCK}}$ high/low-level width	$t_{\text{KL3}}, t_{\text{KH3}}$	$V_{DD} = 2.7$ to 5.5 V	$t_{\text{KCY3}}/2-50$			ns		
			$t_{\text{KCY3}}/2-150$			ns		
SB0, 1 setup time (to $\overline{\text{SCK}}\uparrow$)	t_{SIK3}	$V_{DD} = 2.7$ to 5.5 V	150			ns		
			500			ns		
SB0, 1 hold time (from $\overline{\text{SCK}}\uparrow$)	t_{KSI3}		$t_{\text{KCY3}}/2$			ns		
Delay time from $\overline{\text{SCK}}\downarrow$ to SB0, 1 output	t_{KSO3}	$R_L = 1$ k Ω , $C_L = 100$ pF	Note		$V_{DD} = 2.7$ to 5.5 V	0	250	ns
			0	1000		ns		
SB0, 1 \downarrow from $\overline{\text{SCK}}\uparrow$	t_{KSB}		t_{KCY3}			ns		
$\overline{\text{SCK}}\downarrow$ from SB0, 1 \downarrow	t_{SBK}		t_{KCY3}			ns		
SB0, 1 low-level width	t_{SBL}		t_{KCY3}			ns		
SB0, 1 high-level width	t_{SBH}		t_{KCY3}			ns		

Note R_L and C_L are the load resistance and load capacitance of the SB0, SB1 output line.

SBI Mode ($\overline{\text{SCK}}$...External Clock Input (Slave)): ($T_A = -40$ to $+85^\circ\text{C}$, $V_{DD} = 1.8$ to 5.5 V)

Parameter	Symbol	Test Conditions	MIN.	TYP.	MAX.	Unit		
$\overline{\text{SCK}}$ cycle time	t_{KCY4}	$V_{DD} = 2.7$ to 5.5 V	800			ns		
			3200			ns		
$\overline{\text{SCK}}$ high/low-level width	$t_{\text{KL4}}, t_{\text{KH4}}$	$V_{DD} = 2.7$ to 5.5 V	400			ns		
			1600			ns		
SB0, 1 setup time (to $\overline{\text{SCK}}\uparrow$)	t_{SIK4}	$V_{DD} = 2.7$ to 5.5 V	100			ns		
			150			ns		
SB0, 1 hold time (from $\overline{\text{SCK}}\uparrow$)	t_{KSI4}		$t_{\text{KCY4}}/2$			ns		
Delay time from $\overline{\text{SCK}}\downarrow$ to SB0, 1 output	t_{KSO4}	$R_L = 1$ k Ω , $C_L = 100$ pF	Note		$V_{DD} = 2.7$ to 5.5 V	0	300	ns
			0	1000		ns		
SB0, 1 \downarrow from $\overline{\text{SCK}}\uparrow$	t_{KSB}		t_{KCY4}			ns		
$\overline{\text{SCK}}\downarrow$ from SB0, 1 \downarrow	t_{SBK}		t_{KCY4}			ns		
SB0, 1 low-level width	t_{SBL}		t_{KCY4}			ns		
SB0, 1 high-level width	t_{SBH}		t_{KCY4}			ns		

Note R_L and C_L are the load resistance and load capacitance of the SB0, SB1 output line.

AC Timing Test Point (Excluding X1, XT1 inputs)

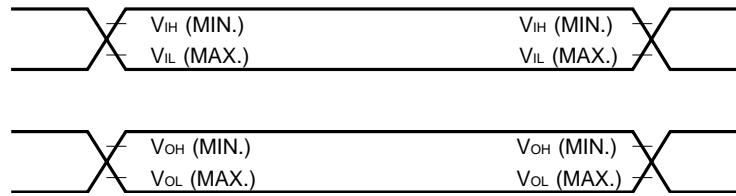

Clock Timing

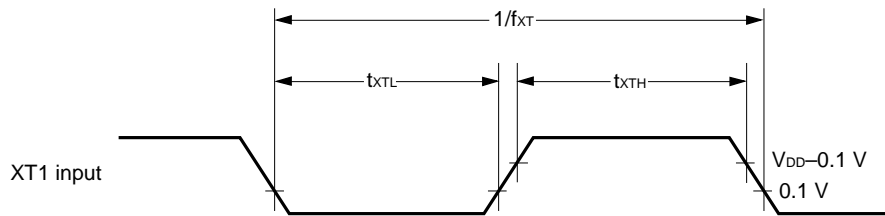
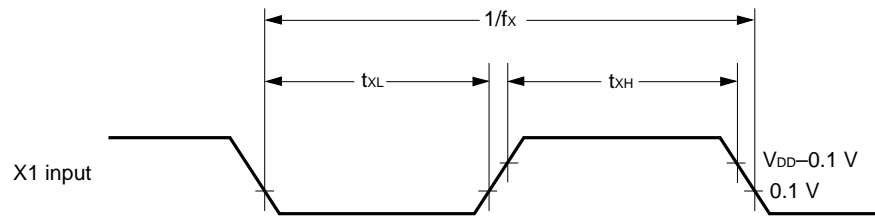

T10, T11, T12 Timing

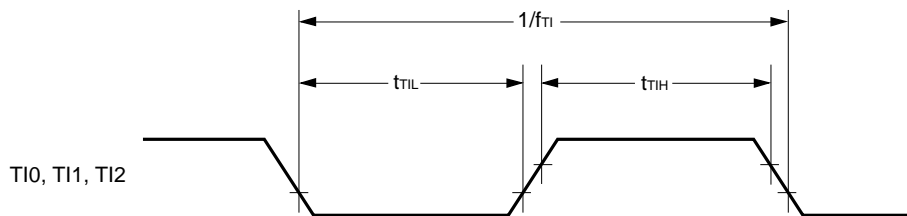

Serial Transfer Timing

3-wire serial I/O mode

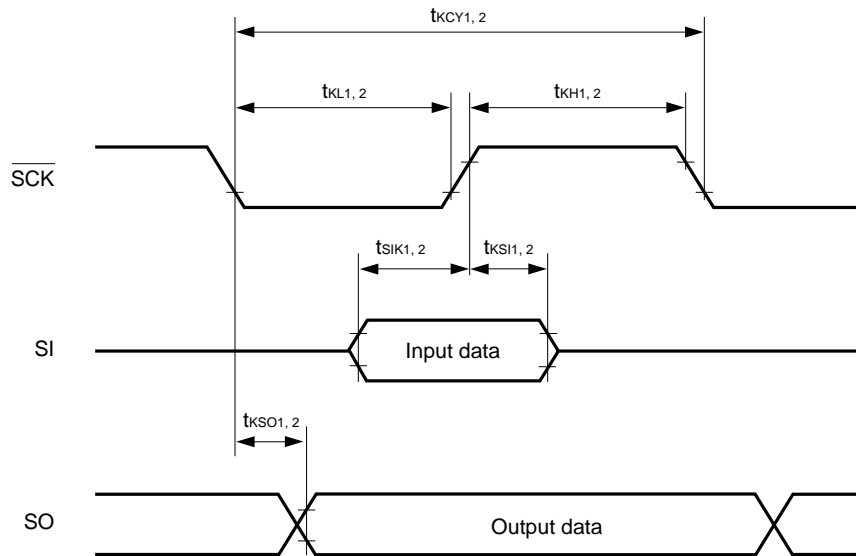

2-wire serial I/O mode

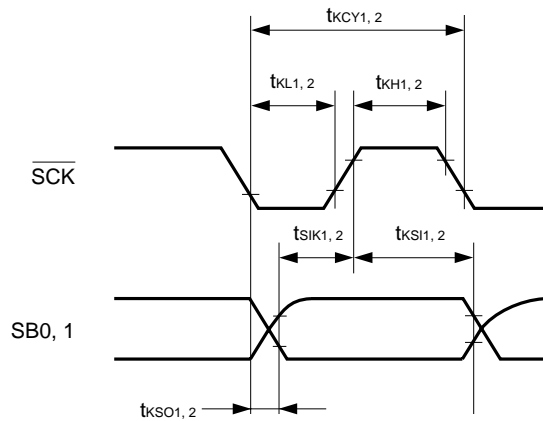

Serial Transfer Timing

Bus release signal transfer

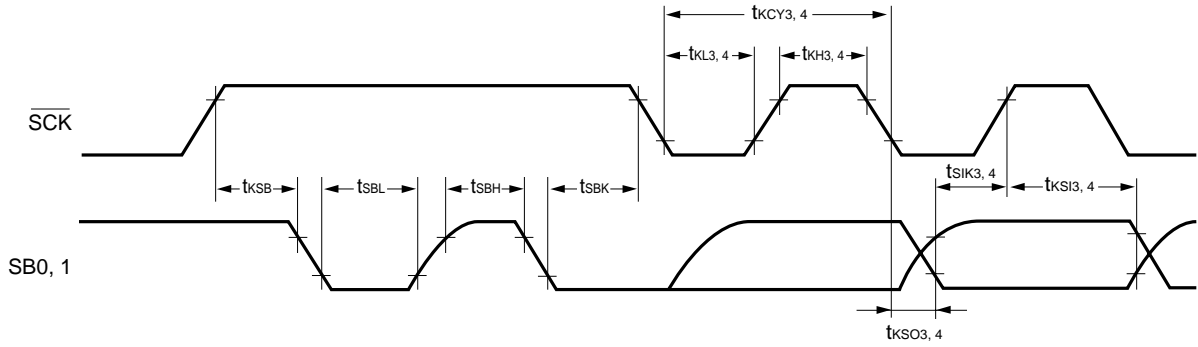

Command signal transfer

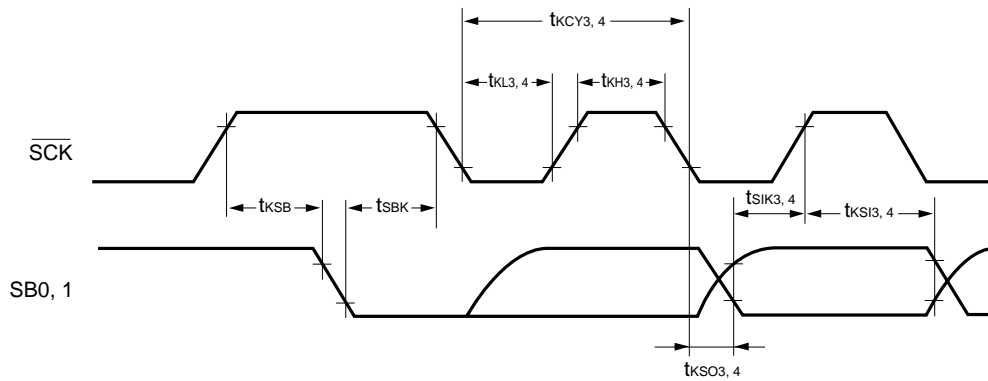

Interrupt input timing

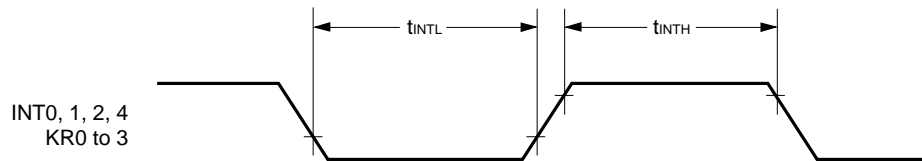

RESET input timing

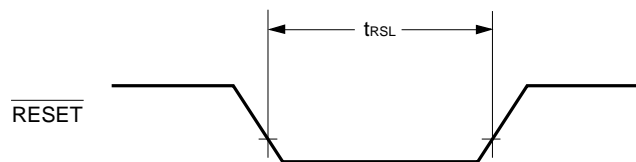

DATA MEMORY STOP MODE LOW SUPPLY VOLTAGE DATA RETENTION CHARACTERISTICS

(T_A = -40 to +85°C)

Parameter	Symbol	Test Conditions	MIN.	TYP.	MAX.	Unit
★ Data retention supply voltage	V _{DDDR}		1.8		5.5	V
Release signal set time	t _{SREL}		0			μs
Oscillation stabilization wait time ^{Note 1}	t _{WAIT}	Release by $\overline{\text{RESET}}$		Note 2		ms
		Release by interrupt request		Note 3		ms

Notes 1. The oscillation stabilization wait time is the time during which the CPU operation is stopped to prevent unstable operation at the oscillation start.

2. Either 2¹⁷/fx or 2¹⁵/fx can be selected by the mask option.

3. Depends on the basic interval timer mode register (BTM) settings (see the table below).

BTM3	BTM2	BTM1	BTM0	Wait time	
				fx = at 4.19 MHz	fx = at 6.0 MHz
—	0	0	0	2 ²⁰ /fx (approx. 250 ms)	2 ²⁰ /fx (approx. 175 ms)
—	0	1	1	2 ¹⁷ /fx (approx. 31.3 ms)	2 ¹⁷ /fx (approx. 21.8 ms)
—	1	0	1	2 ¹⁵ /fx (approx. 7.81 ms)	2 ¹⁵ /fx (approx. 5.46 ms)
—	1	1	1	2 ¹³ /fx (approx. 1.95 ms)	2 ¹³ /fx (approx. 1.37 ms)

Data Retention Timing (STOP Mode Release by $\overline{\text{RESET}}$)

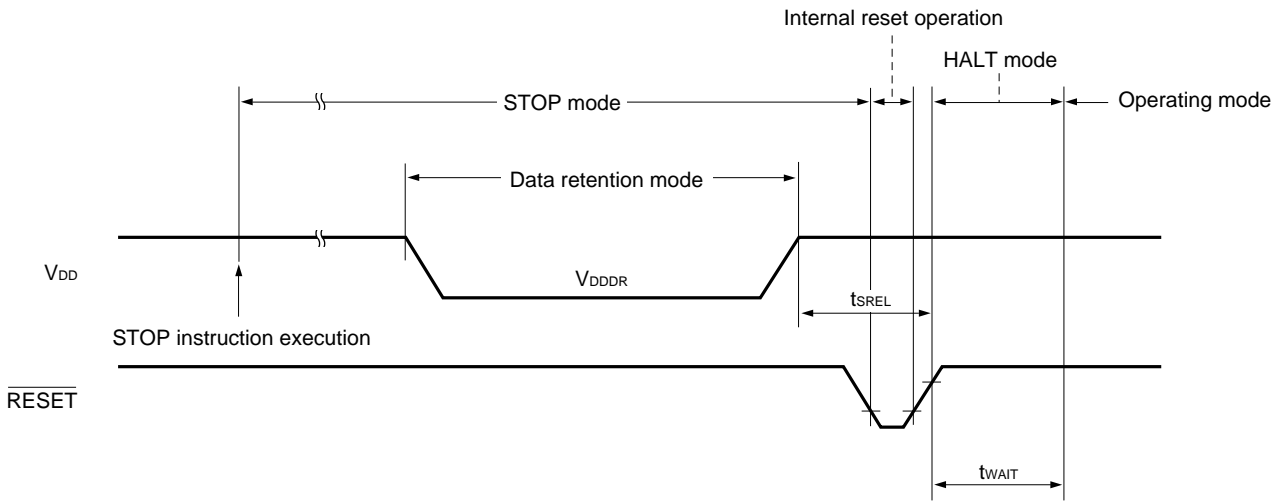

Data Retention Timing (Standby Release Signal: STOP Mode Release by Interrupt Signal)

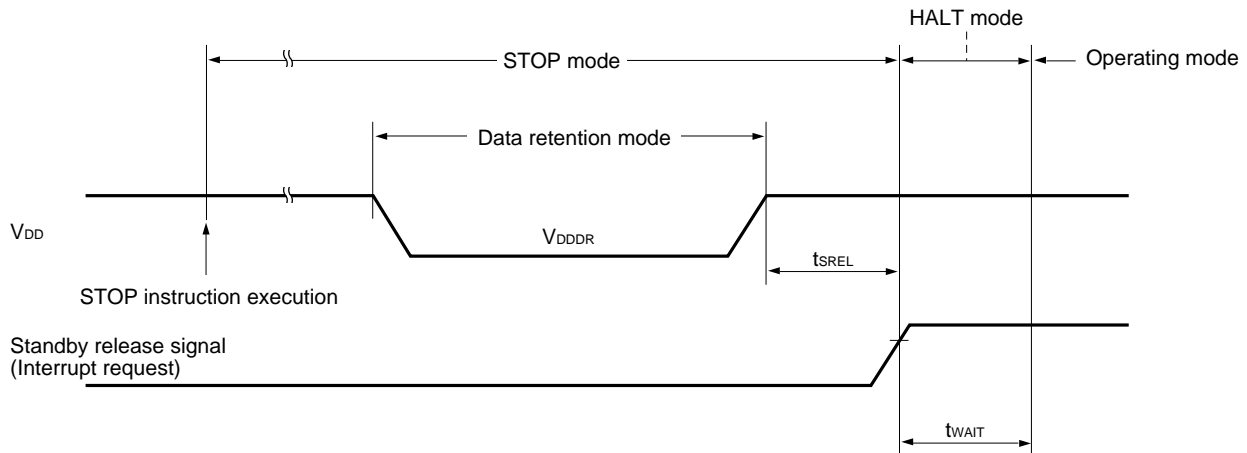

13. CHARACTERISTIC CURVES (FOR REFERENCE ONLY)

I_{DD} vs V_{DD} (Main System Clock: 6.0 MHz Crystal Resonator)

(T_A = 25°C)

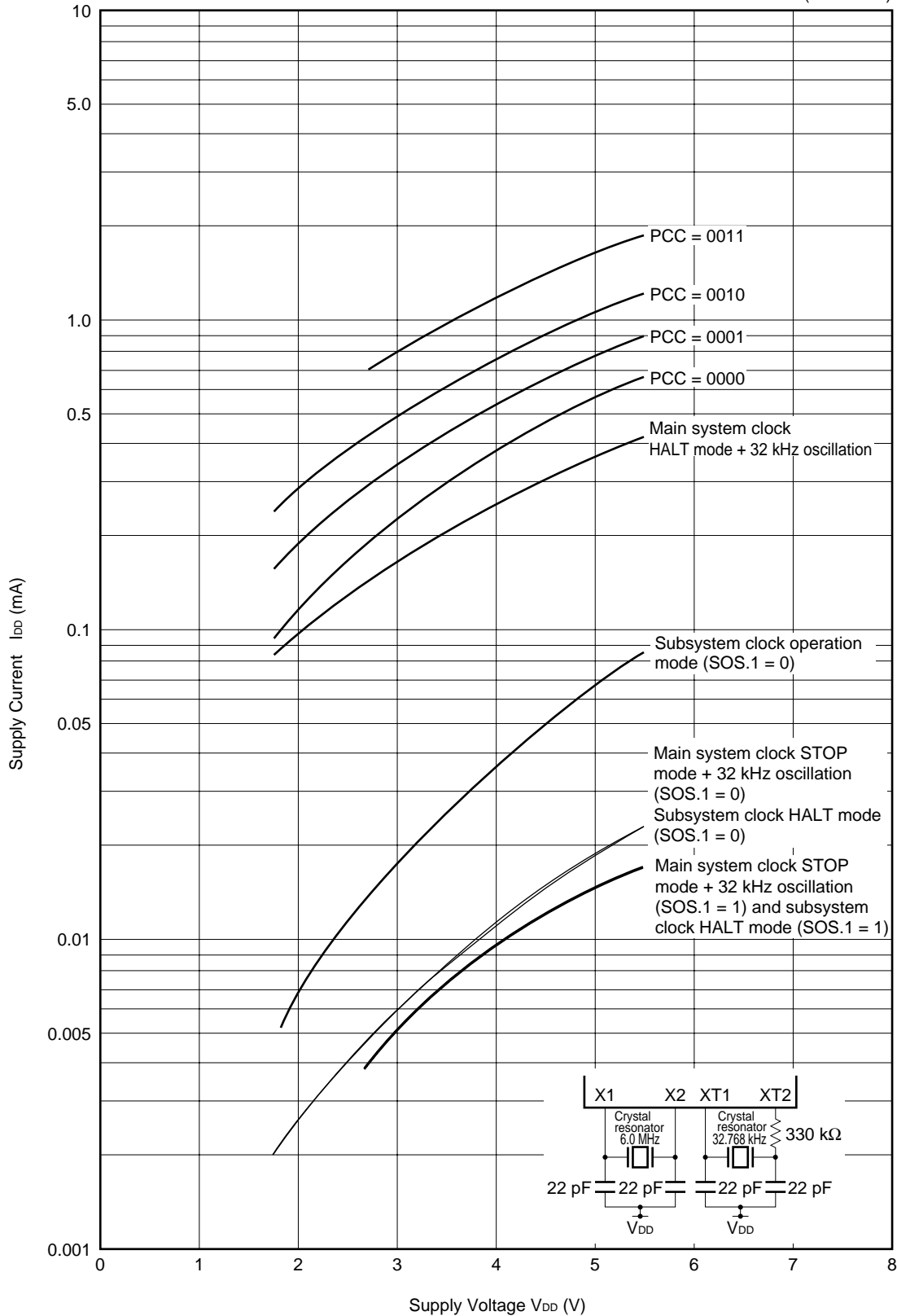

I_{DD} vs V_{DD} (Main System Clock: 4.19 MHz Crystal Resonator)

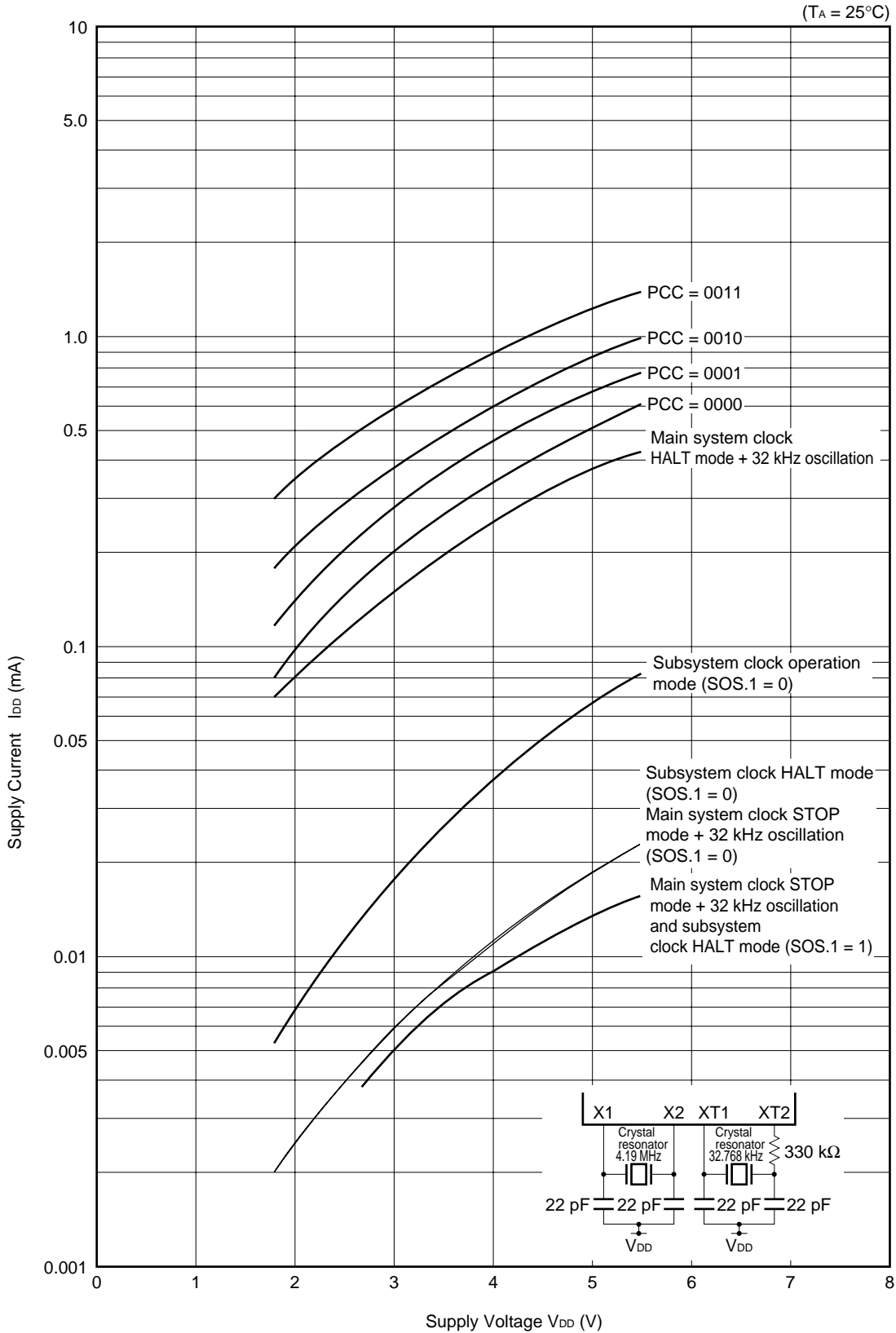

I_{OH} vs $V_{DD}-V_{OH}$ (Ports 2, 3, 6, 8 and 9)

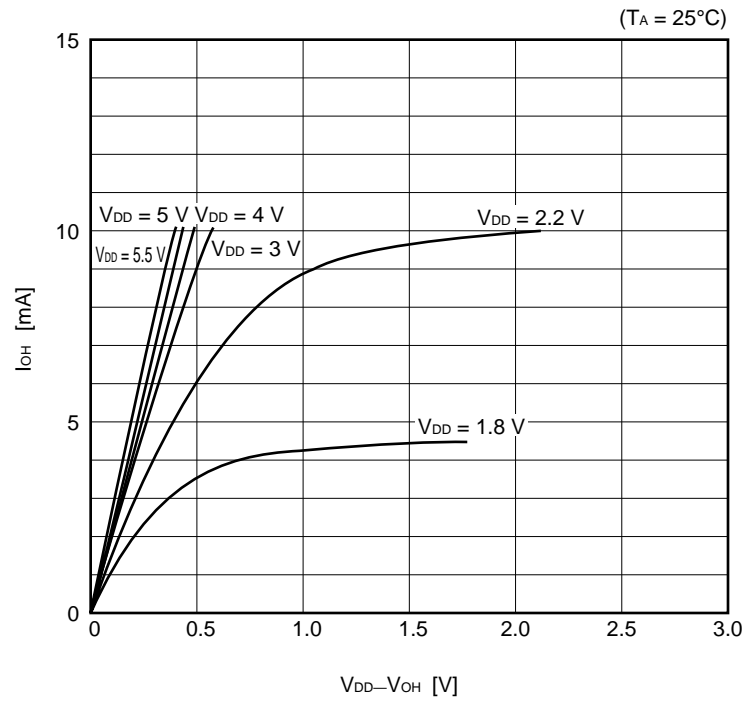

I_{OL} vs V_{OL} (Ports 2, 3, 6, 8 and 9)

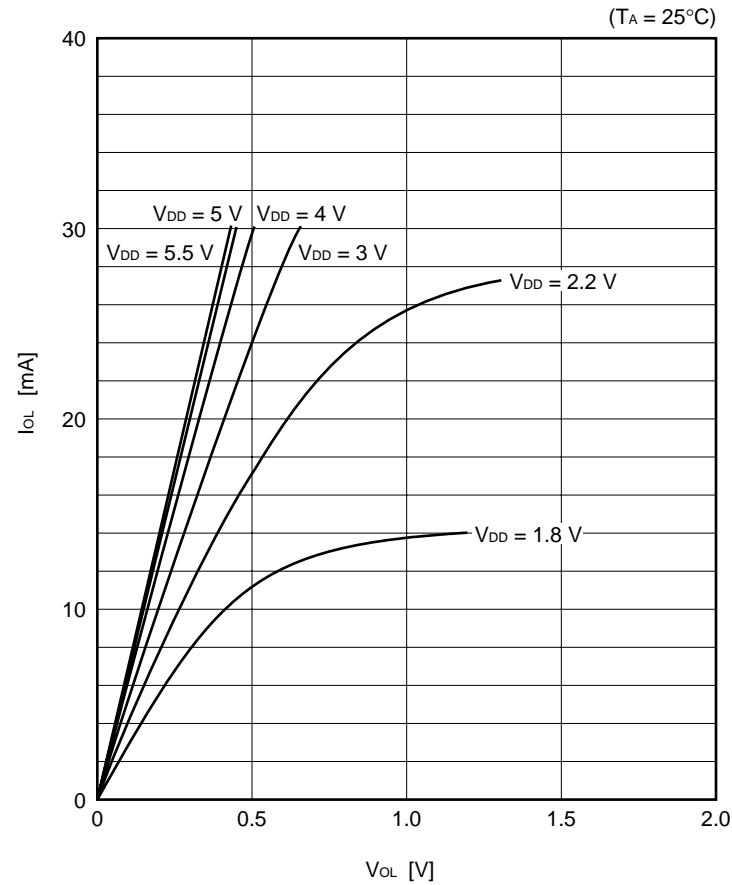

14. PACKAGE DRAWINGS

★ 64-PIN PLASTIC QFP (14 × 14)

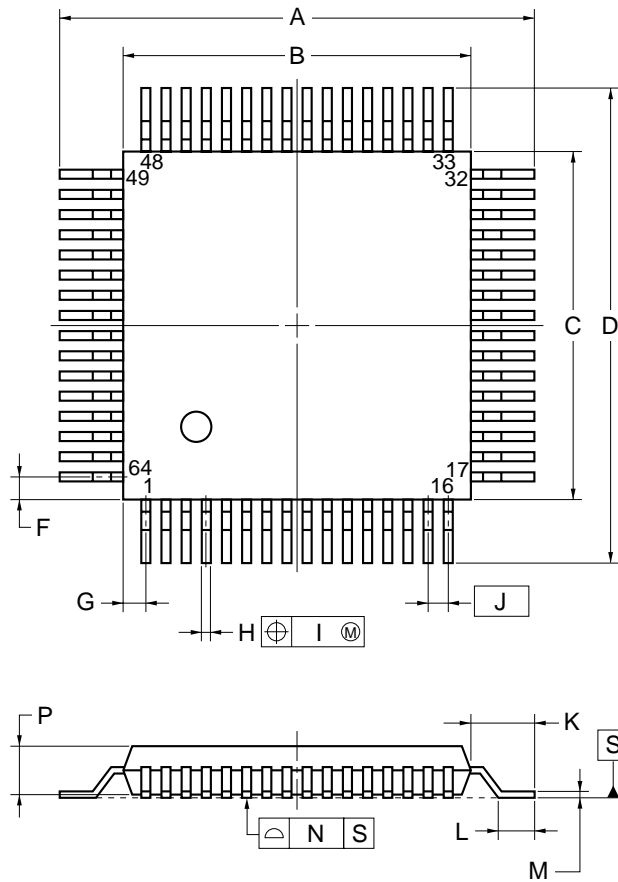

detail of lead end

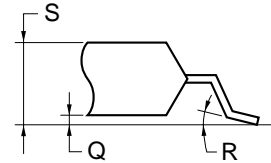

NOTE

Each lead centerline is located within 0.15 mm of its true position (T.P.) at maximum material condition.

ITEM	MILLIMETERS
A	17.6-0.4
B	14.0-0.2
C	14.0-0.2
D	17.6-0.4
F	1.0
G	1.0
H	0.37 ^{+0.08} _{-0.07}
I	0.15
J	0.8 (T.P.)
K	1.8-0.2
L	0.8-0.2
M	0.17 ^{+0.08} _{-0.07}
N	0.10
P	2.55-0.1
Q	0.1-0.1
R	5-5
S	2.85 MAX.

P64GC-80-AB8-5

64-PIN PLASTIC LQFP (12 × 12)

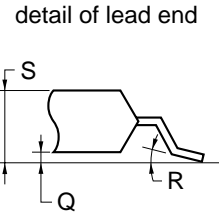
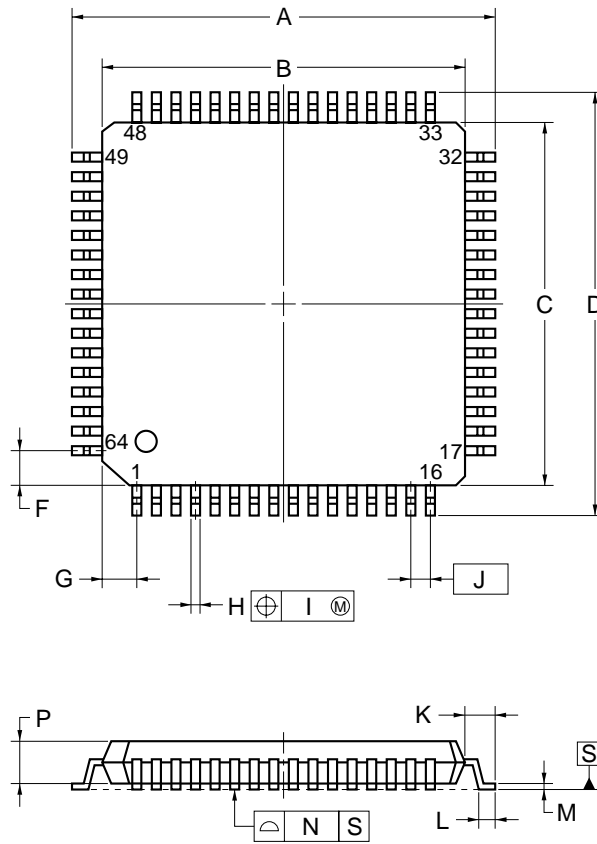

NOTE

Each lead centerline is located within 0.13 mm of its true position (T.P.) at maximum material condition.

ITEM	MILLIMETERS
A	14.8-0.4
B	12.0-0.2
C	12.0-0.2
D	14.8-0.4
F	1.125
G	1.125
H	0.32-0.08
I	0.13
J	0.65 (T.P.)
K	1.4-0.2
L	0.6-0.2
M	0.17 ^{+0.08} _{-0.07}
N	0.10
P	1.4-0.1
Q	0.125-0.075
R	5-5
S	1.7 MAX.

P64GK-65-8A8-3

64-PIN PLASTIC TQFP (12 × 12)

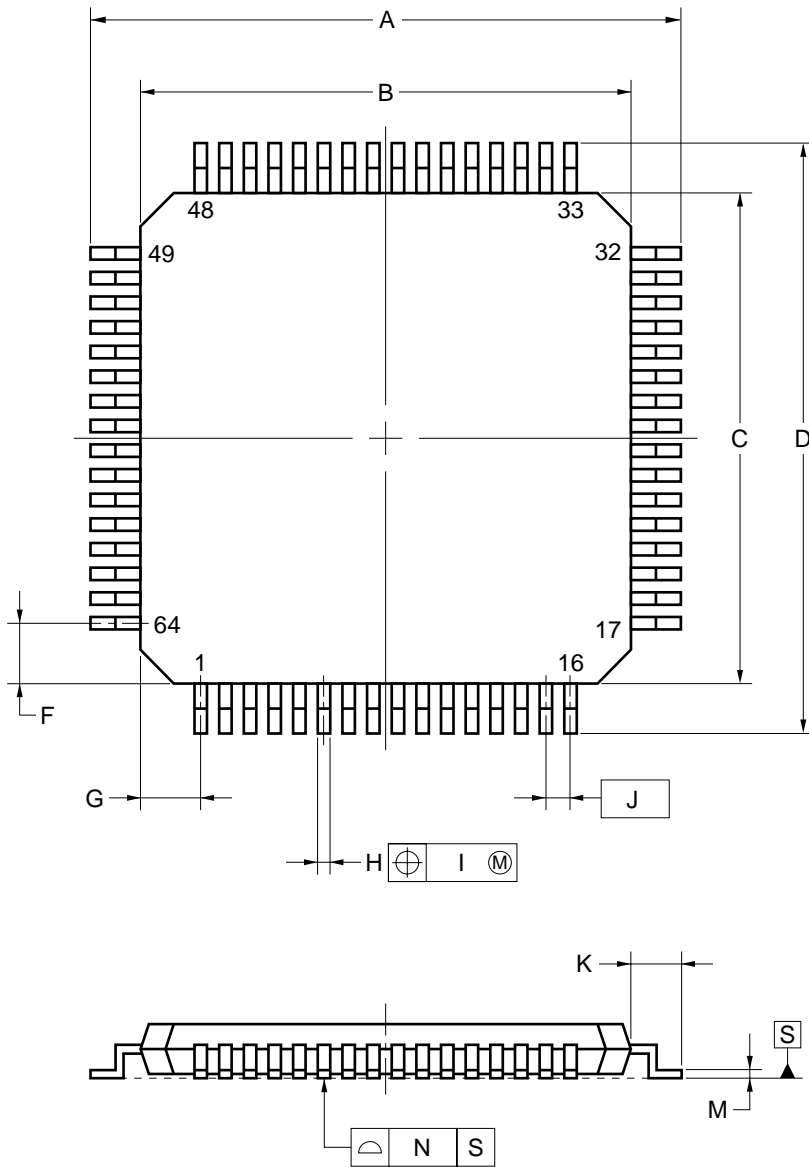

NOTE
 Each lead centerline is located within 0.13 mm of its true position (T.P.) at maximum material condition.

ITEM	MILLIMETERS
A	14.0-0.2
B	12.0-0.2
C	12.0-0.2
D	14.0-0.2
F	1.125
G	1.125
H	0.32 ^{+0.06} _{-0.10}
I	0.13
J	0.65 (T.P.)
K	1.0-0.2
L	0.5
M	0.17 ^{+0.03} _{-0.07}
N	0.10
P	1.0
Q	0.1-0.05
R	3 ⁺⁴ ₋₃
S	1.1-0.1
T	0.25
U	0.6-0.15

P64GK-65-9ET-2

15. RECOMMENDED SOLDERING CONDITIONS

The μPD753108 should be soldered and mounted under the conditions recommended in the table below.

For details of recommended soldering conditions, refer to the document **Semiconductor Device Mounting Technology Manual (C10535E)**.

For soldering methods and conditions other than those recommended below, contact an NEC sales representative.

Table 15-1. Surface Mounting Type Soldering Conditions (1/2)

(1) μPD753104GC-xxx-AB8 : 64-pin plastic QFP (14 × 14)

μPD753106GC-xxx-AB8 : 64-pin plastic QFP (14 × 14)

μPD753108GC-xxx-AB8 : 64-pin plastic QFP (14 × 14)

Soldering Method	Soldering Conditions	Symbol
Infrared reflow	Package peak temperature: 235°C, Time: 30 seconds max. (at 210°C min.), Count: Three times or less	IR35-00-3
VPS	Package peak temperature: 215°C, Time: 40 seconds max. (at 200°C min.), Count: Three times or less	VP15-00-3
Wave soldering	Solder temperature: 260°C max., Time: 10 seconds max., Count: Once, Preheating temperature: 120°C max. (package surface temperature)	WS60-00-1
Partial heating	Pin temperature: 300°C max., Time: 3 seconds max. (per pin row)	—

Caution Do not use different soldering methods together (except for partial heating).

(2) μPD753104GK-xxx-8A8 : 64-pin plastic LQFP (12 × 12)

μPD753106GK-xxx-8A8 : 64-pin plastic LQFP (12 × 12)

μPD753108GK-xxx-8A8 : 64-pin plastic LQFP (12 × 12)

Soldering Method	Soldering Conditions	Symbol
Infrared reflow	Package peak temperature: 235°C, Time: 30 seconds max. (at 210°C min.), Count: Two times or less	IR35-00-2
VPS	Package peak temperature: 215°C, Time: 40 seconds max. (at 200°C min.), Count: Two times or less	VP15-00-2
Wave soldering	Solder temperature: 260°C max., Time: 10 seconds max., Count: Once, Preheating temperature: 120°C max. (package surface temperature)	WS60-00-1
Partial heating	Pin temperature: 300°C max., Time: 3 seconds max. (per pin row)	—

Caution Do not use different soldering methods together (except for partial heating).

Table 15-1. Surface Mounting Type Soldering Conditions (2/2)

- ★ (3) μPD753104GK-xxx-9ET : 64-pin plastic TQFP (12 × 12)
- μPD753106GK-xxx-9ET : 64-pin plastic TQFP (12 × 12)
- μPD753108GK-xxx-9ET : 64-pin plastic TQFP (12 × 12)

Soldering Method	Soldering Conditions	Symbol
Infrared reflow	Package peak temperature: 235°C, Time: 30 seconds max. (at 210°C min.), Count: Two times or less, Exposure limit: 7 days ^{Note} (after that, prebake at 125°C for 10 hours)	IR35-107-2
VPS	Package peak temperature: 215°C, Time: 40 seconds max. (at 200°C min.), Count: Two times or less, Exposure limit: 7 days ^{Note} (after that, prebake at 125°C for 10 hours)	VP15-107-2
Wave soldering	Solder bath temperature: 260°C max., Time: 10 seconds max., Count: Once, Preheating temperature: 120°C max. (package surface temperature), Exposure limit: 7 days ^{Note} (after that, prebake at 125°C for 10 hours)	WS60-107-1
Partial heating	Pin temperature: 300°C max., Time: 3 seconds max. (per pin row)	—

Note After opening the dry pack, store it at 25°C or less and 65% RH or less for the allowable storage period.

Caution Do not use different soldering methods together (except for partial heating).

APPENDIX A. μPD75308B, 753108 AND 75P3116 FUNCTIONAL LIST

Parameter		μPD75308B	μPD753108	μPD75P3116
Program memory		Mask ROM 0000H to 1F7FH (8064 × 8 bits)	Mask ROM 0000H to 1FFFH (8192 × 8 bits)	One-time PROM 0000H to 3FFFH (16384 × 8 bits)
Data memory		000H to 1FFH (512 × 4 bits)		
CPU		75X Standard	75XL CPU	
Instruction execution time	When main system clock is selected	0.95, 1.91, 15.3 μs (during 4.19 MHz operation)	<ul style="list-style-type: none"> • 0.95, 1.91, 3.81, 15.3 μs (during 4.19 MHz operation) • 0.67, 1.33, 2.67, 10.7 μs (during 6.0 MHz operation) 	
	When subsystem clock is selected	122 μs (32.768 kHz operation)		
Stack	SBS register	None	SBS.3 = 1: Mk I mode selection SBS.3 = 0: Mk II mode selection	
	Stack area	000H to 0FFH	000H to 1FFH	
	Subroutine call instruction stack operation	2-byte stack	When Mk I mode: 2-byte stack When Mk II mode: 3-byte stack	
Instruction	BRA !addr1 CALLA !addr1	Unavailable	When Mk I mode: unavailable When Mk II mode: available	
	MOVT XA, @BCDE MOVT XA, @BCXA BR BCDE BR BCXA		Available	
	CALL !addr	3 machine cycles	Mk I mode: 3 machine cycles, Mk II mode: 4 machine cycles	
	CALLF !faddr	2 machine cycles	Mk I mode: 2 machine cycles, Mk II mode: 3 machine cycles	
I/O port	CMOS input	8	8	
	CMOS input/output	16	20	
	Bit port output	8	0	
	N-ch open-drain input/output	8	4	
	Total	40	32	
LCD controller/driver		Segment selection: 24/28/32 segments (can be changed to CMOS input/output port in 4 time-unit; max. 8)	Segment selection: 16/20/24 segments (can be changed to CMOS input/output port in 4 time-unit; max. 8)	
		Display mode selection: static, 1/2 duty (1/2 bias), 1/3 duty (1/2 bias), 1/3 duty (1/3 bias), 1/4 duty (1/3 bias)		
		On-chip split resistor for LCD driver can be specified by using mask option.	No on-chip split resistor for LCD driver	
Timer		3 channels <ul style="list-style-type: none"> • Basic interval timer: 1 channel • 8-bit timer/event counter: 1 channel • Watch timer: 1 channel 	5 channels <ul style="list-style-type: none"> • Basic interval timer/watchdog timer: 1 channel • 8-bit timer/event counter: 3 channels (can be used as 16-bit timer/event counter) • Watch timer: 1 channel 	

Parameter		μPD75308B	μPD753108	μPD75P3116
Clock output (PCL)		<ul style="list-style-type: none"> • Φ, 524, 262, 65.5 kHz (Main system clock: during 4.19 MHz operation) 	<ul style="list-style-type: none"> • Φ, 524, 262, 65.5 kHz (Main system clock: during 4.19 MHz operation) • Φ, 750, 375, 93.8 kHz (Main system clock: during 6.0 MHz operation) 	
BUZ output (BUZ)		<ul style="list-style-type: none"> • 2 kHz (Main system clock: during 4.19 MHz operation) 	<ul style="list-style-type: none"> • 2, 4, 32 kHz (Main system clock: during 4.19 MHz operation or subsystem clock: during 32.768 kHz operation) • 2.93, 5.86, 46.9 kHz (Main system clock: 6.0 MHz operation) 	
Serial interface		3 modes are available <ul style="list-style-type: none"> • 3-wire serial I/O mode ... MSB/LSB can be selected for transfer first bit • 2-wire serial I/O mode • SBI mode 		
SOS register	Feedback resistor cut flag (SOS.0)	None	Contained	
	Sub-oscillator current cut flag (SOS.1)	None	Contained	
Register bank selection register (RBS)		None	Yes	
Standby release by INT0		Unavailable	Available	
Vectored interrupt		External: 3, internal: 3	External: 3, internal: 5	
Supply voltage		V _{DD} = 2.0 to 6.0 V	V _{DD} = 1.8 to 5.5 V	
Operating ambient temperature		T _A = -40 to +85°C		
★	Package	<ul style="list-style-type: none"> • 80-pin plastic QFP (14 × 20) • 80-pin plastic QFP (14 × 14) • 80-pin plastic TQFP (Fine pitch) (12 × 12) 	<ul style="list-style-type: none"> • 64-pin plastic QFP (14 × 14) • 64-pin plastic LQFP (12 × 12) • 64-pin plastic TQFP (12 × 12) 	<ul style="list-style-type: none"> • 64-pin plastic QFP (14 × 14) • 64-pin plastic LQFP (12 × 12)

APPENDIX B. DEVELOPMENT TOOLS

The following development tools are provided for system development using the μPD753108.

In the 75XL Series, the relocatable assembler which is common to the series is used in combination with the device file of each product.

Language processor

★

RA75X relocatable assembler	Host Machine	OS	Supply Media	Part Number (Product Name)
	PC-9800 Series	MS-DOS™ (Ver. 3.30 to Ver. 6.2 ^{Note})	3.5-inch 2HD	μS5A13RA75X
	IBM PC/AT™ and compatible machines	Refer to "OS for IBM PC"	3.5-inch 2HC	μS7B13RA75X

★

Device file	Host Machine	OS	Supply Media	Part Number (Product Name)
	PC-9800 Series	MS-DOS (Ver. 3.30 to Ver. 6.2 ^{Note})	3.5-inch 2HD	μS5A13DF753108
	IBM PC/AT and compatible machines	Refer to "OS for IBM PC"	3.5-inch 2HC	μS7B13DF753108

Note Ver. 5.00 and later have the task swap function, but it cannot be used for this software.

Remark Operation of the assembler and the device file is guaranteed only on the above host machines and OSs.

PROM write tools

Hardware	PG-1500	PG-1500 is a PROM programmer which enables you to program single-chip microcontrollers including PROM by stand-alone or host machine operation by connecting an attached board and optional programmer adapter to PG-1500. It also enables you to program typical PROM devices of 256K bits to 4M bits.			
	PA-75P3116GC	PROM programmer adapter for the μPD75P3116GC. Connect the programmer adapter to PG-1500 for use.			
	PA-75P3116GK	PROM programmer adapter for the μPD75P3116GK. Connect the programmer adapter to PG-1500 for use.			
Software	PG-1500 controller	PG-1500 and a host machine are connected by serial and parallel interfaces and PG-1500 is controlled on the host machine.			
		Host machine	OS	Supply media	Part number (product name)
		PC-9800 Series	MS-DOS (Ver. 3.30 to Ver. 6.2 ^{Note})	3.5-inch 2HD	μS5A13PG1500
		IBM PC/AT and compatible machines	Refer to "OS for IBM PC"	3.5-inch 2HD	μS7B13PG1500

Note Ver. 5.00 and later have the task swap function, but it cannot be used for this software.

Remark Operation of the PG-1500 controller is guaranteed only on the above host machines and OSs.

Debugging tool

The in-circuit emulators (IE-75000-R and IE-75001-R) are available as the program debugging tool for the μPD753108.

The system configurations are described as follows.

Hardware	IE-75000-R ^{Note 1}	In-circuit emulator for debugging the hardware and software when developing the application systems that use the 75X Series and 75XL Series. When developing a μPD753108 Subseries, the emulation board (IE-75300-R-EM) and emulation probe (EP-753108GC-R or EP-753108GK-R) that are sold separately must be used with the IE-75000-R. By connecting with the host machine and the PROM programmer, efficient debugging can be made. It contains the emulation board (IE-75000-R-EM) which is connected.			
	IE-75001-R	In-circuit emulator for debugging the hardware and software when developing the application systems that use the 75X Series and 75XL Series. When developing a μPD753108 Subseries, the emulation board (IE-75300-R-EM) and emulation probe (EP-753108GC-R or EP-753108GK-R) that are sold separately must be used with the IE-75001-R. It can debug the system efficiently by connecting the host machine and PROM programmer.			
	IE-75300-R-EM	Emulation board for evaluating the application systems that use a μPD753108 Subseries. It must be used with the IE-75000-R or IE-75001-R.			
	EP-753108GC-R	Emulation probe for the μPD753108GC. It must be connected to IE-75000-R (or IE-75001-R) and IE-75300-R-EM. It is supplied with the 64-pin conversion socket EV-9200GC-64 which facilitates connection to a target system.			
	EV-9200GC-64				
Software	IE control program	Connects the IE-75000-R or IE-75001-R to a host machine via RS-232-C and Centronics interface and controls the IE-75000-R or IE-75001-R on a host machine.			
		Host machine	OS	Supply media	Part No. (product name)
		PC-9800 Series	MS-DOS	3.5-inch 2HD	μS5A13IE75X
			(Ver. 3.30 to Ver. 6.2 ^{Note 3})	5-inch 2HD	μS5A10IE75X
		IBM PC/AT and compatible machines	Refer to "OS for IBM PC"	3.5-inch 2HC	μS7B13IE75X
5-inch 2HC	μS7B10IE75X				
EP-753108GK-R	Emulation probe for the μPD753108GK. It must be connected to the IE-75000-R (or IE-75001-R) and IE-75300-R-EM. It is supplied with the 64-pin conversion adapter TKG-064SBW which facilitates connection to a target system.				
TKG-064SBW ^{Note 2}					

Notes 1. Maintenance product.

★

2. This is a product of TOKYO ELETECH CORPORATION.

Contact: Daimaru Kogyo, Ltd. Tokyo Electronic Department (TEL: +81-3-3820-7112)

Osaka Electronic Department (TEL: +81-6-6244-6672)

3. Ver. 5.00 and later have the task swap function, but it cannot be used for this software.

Remarks 1. Operation of the IE control program is guaranteed only on the above host machines and OSs.

2. The μPD753104, 753106, 753108 and 75P3116 are commonly referred to as the μPD753108 Subseries.

OS for IBM PC

The following IBM PC OS's are supported.

OS	Version
PC DOS™	Ver. 3.1 to Ver. 6.3 J6.1/V ^{Note} to J6.3/V ^{Note}
MS-DOS	Ver. 5.0 to Ver. 6.22 5.0/V ^{Note} to 6.2/V ^{Note}
IBM DOS™	J5.02/V ^{Note}

Note Only the English mode is supported.

Caution Ver. 5.0 and later have the task swap function, but it cannot be used for this software.

APPENDIX C. RELATED DOCUMENTS

The related documents indicated in this publication may include preliminary versions. However, preliminary versions are not marked as such.

Device Related Documents

Document Name	Document No.	
	English	Japanese
μPD753104, 753106, 753108 Data Sheet	U10086E (This document)	U10086J
μPD75P3116 Data Sheet	U11369E	U11369J
μPD753108 User's Manual	U10890E	U10890J
75XL Series Selection Guide	U10453E	U10453J

Development Tool Related Documents

Document Name		Document No.		
		English	Japanese	
Hardware	IE-75000-R/IE-75001-R User's Manual		EEU-1416	EEU-846
	IE-75300-R-EM User's Manual		U11354E	U11354J
	EP-753108GC/GK-R User's Manual		EEU-1495	EEU-968
	PG-1500 User's Manual		U11940E	U11940J
Software	RA75X Assembler Package	Operation	U12622E	U12622J
		User's Manual	U12385E	U12385J
	PG-1500 Controller User's Manual	PC-9800 series (MS-DOS) base	EEU-1291	EEU-704
		IBM PC series (PC DOS) base	U10540E	EEU-5008

Other Related Documents

	Document Name	Document No.	
		English	Japanese
★	SEMICONDUCTOR SELECTION GUIDE Products & Packages (CD-ROM)	X13769X	
	Semiconductor Device Mounting Technology Manual	C10535E	C10535J
	Quality Grades on NEC Semiconductor Devices	C11531E	C11531J
	NEC Semiconductor Device Reliability/Quality Control System	C10983E	C10983J
★	Guide to Prevent Damage for Semiconductor Devices by Electrostatic Discharge (ESD)	C11892E	C11892J
	Guide to Microcomputer-Related Products by Third Party	—	U11416J

Caution The related documents listed above are subject to change without notice. Be sure to use the latest version of each document for designing.

NOTES FOR CMOS DEVICES**① PRECAUTION AGAINST ESD FOR SEMICONDUCTORS**

Note:

Strong electric field, when exposed to a MOS device, can cause destruction of the gate oxide and ultimately degrade the device operation. Steps must be taken to stop generation of static electricity as much as possible, and quickly dissipate it once, when it has occurred. Environmental control must be adequate. When it is dry, humidifier should be used. It is recommended to avoid using insulators that easily build static electricity. Semiconductor devices must be stored and transported in an anti-static container, static shielding bag or conductive material. All test and measurement tools including work bench and floor should be grounded. The operator should be grounded using wrist strap. Semiconductor devices must not be touched with bare hands. Similar precautions need to be taken for PW boards with semiconductor devices on it.

② HANDLING OF UNUSED INPUT PINS FOR CMOS

Note:

No connection for CMOS device inputs can be cause of malfunction. If no connection is provided to the input pins, it is possible that an internal input level may be generated due to noise, etc., hence causing malfunction. CMOS devices behave differently than Bipolar or NMOS devices. Input levels of CMOS devices must be fixed high or low by using a pull-up or pull-down circuitry. Each unused pin should be connected to V_{DD} or GND with a resistor, if it is considered to have a possibility of being an output pin. All handling related to the unused pins must be judged device by device and related specifications governing the devices.

③ STATUS BEFORE INITIALIZATION OF MOS DEVICES

Note:

Power-on does not necessarily define initial status of MOS device. Production process of MOS does not define the initial operation status of the device. Immediately after the power source is turned ON, the devices with reset function have not yet been initialized. Hence, power-on does not guarantee out-pin levels, I/O settings or contents of registers. Device is not initialized until the reset signal is received. Reset operation must be executed immediately after power-on for devices having reset function.

Regional Information

Some information contained in this document may vary from country to country. Before using any NEC product in your application, please contact the NEC office in your country to obtain a list of authorized representatives and distributors. They will verify:

- Device availability
- Ordering information
- Product release schedule
- Availability of related technical literature
- Development environment specifications (for example, specifications for third-party tools and components, host computers, power plugs, AC supply voltages, and so forth)
- Network requirements

In addition, trademarks, registered trademarks, export restrictions, and other legal issues may also vary from country to country.

NEC Electronics Inc. (U.S.)

Santa Clara, California
 Tel: 408-588-6000
 800-366-9782
 Fax: 408-588-6130
 800-729-9288

NEC Electronics (Germany) GmbH

Duesseldorf, Germany
 Tel: 0211-65 03 02
 Fax: 0211-65 03 490

NEC Electronics (UK) Ltd.

Milton Keynes, UK
 Tel: 01908-691-133
 Fax: 01908-670-290

NEC Electronics Italiana s.r.l.

Milano, Italy
 Tel: 02-66 75 41
 Fax: 02-66 75 42 99

NEC Electronics (Germany) GmbH

Benelux Office
 Eindhoven, The Netherlands
 Tel: 040-2445845
 Fax: 040-2444580

NEC Electronics (France) S.A.

Velizy-Villacoublay, France
 Tel: 01-30-67 58 00
 Fax: 01-30-67 58 99

NEC Electronics (France) S.A.

Madrid Office
 Madrid, Spain
 Tel: 91-504-2787
 Fax: 91-504-2860

NEC Electronics (Germany) GmbH

Scandinavia Office
 Taebly, Sweden
 Tel: 08-63 80 820
 Fax: 08-63 80 388

NEC Electronics Hong Kong Ltd.

Hong Kong
 Tel: 2886-9318
 Fax: 2886-9022/9044

NEC Electronics Hong Kong Ltd.

Seoul Branch
 Seoul, Korea
 Tel: 02-528-0303
 Fax: 02-528-4411

NEC Electronics Singapore Pte. Ltd.

United Square, Singapore
 Tel: 65-253-8311
 Fax: 65-250-3583

NEC Electronics Taiwan Ltd.

Taipei, Taiwan
 Tel: 02-2719-2377
 Fax: 02-2719-5951

NEC do Brasil S.A.

Electron Devices Division
 Guarulhos-SP Brasil
 Tel: 55-11-6462-6810
 Fax: 55-11-6462-6829

J00.7

MS-DOS is either a registered trademark or a trademark of Microsoft Corporation in the United States and/or other countries.

IBM DOS, PC/AT, and PC DOS are trademarks of International Business Machines Corporation.

The export of this product from Japan is regulated by the Japanese government. To export this product may be prohibited without governmental license, the need for which must be judged by the customer. The export or re-export of this product from a country other than Japan may also be prohibited without a license from that country. Please call an NEC sales representative.

• **The information in this document is current as of September, 2000. The information is subject to change without notice. For actual design-in, refer to the latest publications of NEC's data sheets or data books, etc., for the most up-to-date specifications of NEC semiconductor products. Not all products and/or types are available in every country. Please check with an NEC sales representative for availability and additional information.**

- No part of this document may be copied or reproduced in any form or by any means without prior written consent of NEC. NEC assumes no responsibility for any errors that may appear in this document.
- NEC does not assume any liability for infringement of patents, copyrights or other intellectual property rights of third parties by or arising from the use of NEC semiconductor products listed in this document or any other liability arising from the use of such products. No license, express, implied or otherwise, is granted under any patents, copyrights or other intellectual property rights of NEC or others.
- Descriptions of circuits, software and other related information in this document are provided for illustrative purposes in semiconductor product operation and application examples. The incorporation of these circuits, software and information in the design of customer's equipment shall be done under the full responsibility of customer. NEC assumes no responsibility for any losses incurred by customers or third parties arising from the use of these circuits, software and information.
- While NEC endeavours to enhance the quality, reliability and safety of NEC semiconductor products, customers agree and acknowledge that the possibility of defects thereof cannot be eliminated entirely. To minimize risks of damage to property or injury (including death) to persons arising from defects in NEC semiconductor products, customers must incorporate sufficient safety measures in their design, such as redundancy, fire-containment, and anti-failure features.
- NEC semiconductor products are classified into the following three quality grades:
"Standard", "Special" and "Specific". The "Specific" quality grade applies only to semiconductor products developed based on a customer-designated "quality assurance program" for a specific application. The recommended applications of a semiconductor product depend on its quality grade, as indicated below. Customers must check the quality grade of each semiconductor product before using it in a particular application.

"Standard": Computers, office equipment, communications equipment, test and measurement equipment, audio and visual equipment, home electronic appliances, machine tools, personal electronic equipment and industrial robots

"Special": Transportation equipment (automobiles, trains, ships, etc.), traffic control systems, anti-disaster systems, anti-crime systems, safety equipment and medical equipment (not specifically designed for life support)

"Specific": Aircraft, aerospace equipment, submersible repeaters, nuclear reactor control systems, life support systems and medical equipment for life support, etc.

The quality grade of NEC semiconductor products is "Standard" unless otherwise expressly specified in NEC's data sheets or data books, etc. If customers wish to use NEC semiconductor products in applications not intended by NEC, they must contact an NEC sales representative in advance to determine NEC's willingness to support a given application.

(Note)

(1) "NEC" as used in this statement means NEC Corporation and also includes its majority-owned subsidiaries.

(2) "NEC semiconductor products" means any semiconductor product developed or manufactured by or for NEC (as defined above).