

Analog Peripherals

10-Bit ADC

- Programmable throughput up to 200 ksps
- Up to 16 external inputs; programmable as single-ended or differential
- Reference from internal V_{REF} , V_{DD} , or external pin
- Internal or external start of conversion sources
- Built-in temperature sensor ($\pm 3^\circ\text{C}$)

10-bit DAC (Current Mode)

Comparator

- Programmable hysteresis and response time
- Configurable to generate interrupts or reset
- Low current (0.4 μA)

On-Chip Debug

- On-chip debug circuitry facilitates full speed, non-intrusive in-system debug (no emulator required)
- Provides breakpoints, single stepping, watchpoints
- Inspect/modify memory, registers, and stack
- Superior performance to emulation systems using ICE-chips, target pods, and sockets

Supply Voltage: 2.7 to 3.6 V

- Typical operating current: 6.4 mA at 25 MHz
9 μA at 32 kHz
- Typical stop mode current: <0.1 μA

Temperature Range: -40 to $+85^\circ\text{C}$

High-Speed 8051 μC Core

- Pipelined instruction architecture; executes 70% of instructions in 1 or 2 system clocks
- Up to 25 MIPS throughput with 25 MHz clock
- Expanded interrupt handler

Memory

- 768 bytes data RAM
- 8 kB Flash; in-system programmable in 512 byte sectors (512 bytes are reserved)

Digital Peripherals

- 17 port I/O; all are 5 V tolerant
- Hardware SMBus™ (I2C™ compatible), SPI™, and UART serial ports available concurrently
- Programmable 16-bit counter/timer array with three capture/compare modules, WDT
- 4 general-purpose 16-bit counter/timers
- Real-time clock mode using PCA or timer and external clock source

Clock Sources

- Two internal oscillators:
 - 24.5 MHz, 2% accuracy supports UART operation
 - 80 kHz low frequency, low-power
- External oscillator: Crystal, RC, C, or Clock (1 or 2 pin modes)
- Can switch between clock sources on-the-fly

Package

- 20-pin DIP (lead-free package)

Ordering Part Numbers

- C8051F330D-GP

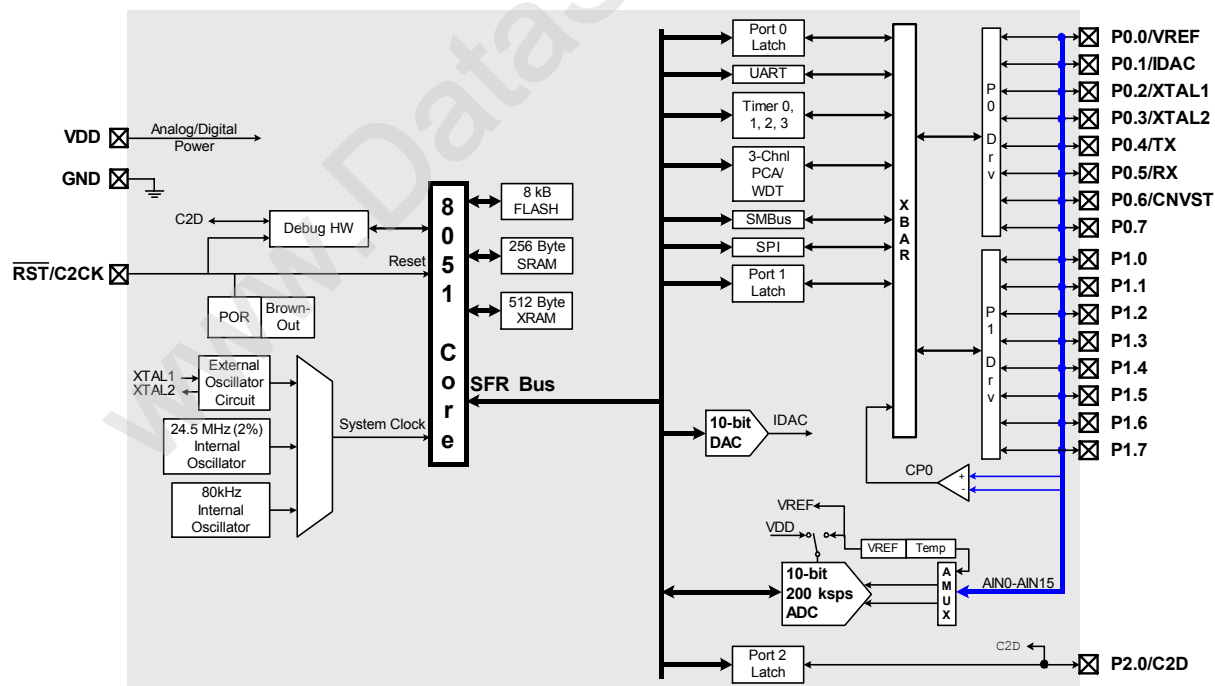

Selected Electrical Specifications

($T_A = -40$ to $+85$ C°, $V_{DD} = 2.7$ V unless otherwise specified)

PARAMETER	CONDITIONS	MIN	TYP	MAX	UNITS
GLOBAL CHARACTERISTICS					
Supply Voltage		2.7		3.6	V
Supply Current with CPU active	Clock = 25 MHz		6.4		mA
	Clock = 1 MHz		0.36		mA
	Clock = 80 kHz; V_{DD} Monitor Disabled		20		μ A
	Clock = 32 kHz; V_{DD} Monitor Disabled		9		μ A
Supply Current (shutdown)	Oscillator off; V_{DD} Monitor Disabled		<0.1		μ A
Clock Frequency Range		DC		25	MHz
INTERNAL OSCILLATORS					
Frequency (OSC0)		24.0	24.5	25.0	MHz
Frequency (OSC1)	Note 1		80		kHz
A/D CONVERTER					
Resolution			10		bits
Integral Nonlinearity			$\pm 1/2$	± 1	LSB
Differential Nonlinearity	Guaranteed Monotonic		$\pm 1/2$	± 1	LSB
Signal-to-Noise Plus Distortion		53	55.5		dB
Throughput Rate				200	ksps
Input Voltage Range		0		V_{REF}	V
D/A CONVERTER					
Resolution			10		bits
Integral Nonlinearity			$\pm 1/2$		LSB
Differential Nonlinearity	Guaranteed Monotonic		$\pm 1/2$	± 1	LSB
Output Settling Time			5		μ s
COMPARATOR					
Response Time Mode0	(CP+) – (CP-) = 100 mV		0.1		μ s
Current Consumption Mode0			7.6		μ A
Response Time Mode1	(CP+) – (CP-) = 100 mV		0.18		μ s
Current Consumption Mode1			3.2		μ A
Response Time Mode2	(CP+) – (CP-) = 100 mV		0.32		μ s
Current Consumption Mode2			1.3		μ A
Response Time Mode3	(CP+) – (CP-) = 100 mV		1		μ s
Current Consumption Mode3			0.4		μ A

Note 1: OSC1 can be calibrated in 2.5% steps using an internal calibration register.

Package Information

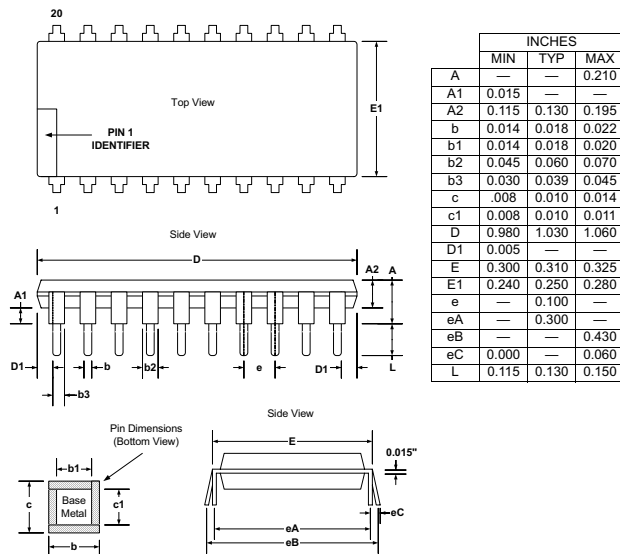

C8051F330DK Development Kit

