HM5116100 Series

16 M FP DRAM (16-Mword × 1-bit)
4 k Refresh

HITACHI

ADE-203-646E (Z)
Rev. 5.0
Nov. 1997

Description

The Hitachi HM5116100 is a CMOS dynamic RAM organized 16,777,216-word × 1-bit. It employs the most advanced 0.5μm CMOS technology for high performance and low power. The HM5116100 offers Fast Page Mode as a high speed access mode. It is packaged in 26-pin plastic SOJ.

Features

- Single 5 V (±10%)
- Access time: 60 ns/70 ns (max)
- Power dissipation
 - Active mode: 440 mW/385 mW (max)
 - Standby mode 11 mW (max)
- Fast page mode capability
- Refresh cycles
 - 4096 refresh cycles : 64 ms
- 3 variations of refresh
 - $\overline{\text{RAS}}$ -only refresh
 - $\overline{\text{CAS}}$ -before- $\overline{\text{RAS}}$ refresh
 - Hidden refresh
- Test function
 - 16-bit parallel test mode

Ordering Information

Type No.	Access time	Package
HM5116100S-6	60 ns	300-mil 26-pin plastic SOJ (CP-26/24DB)
HM5116100S-7	70 ns	

HM5116100 Series

Pin Arrangement

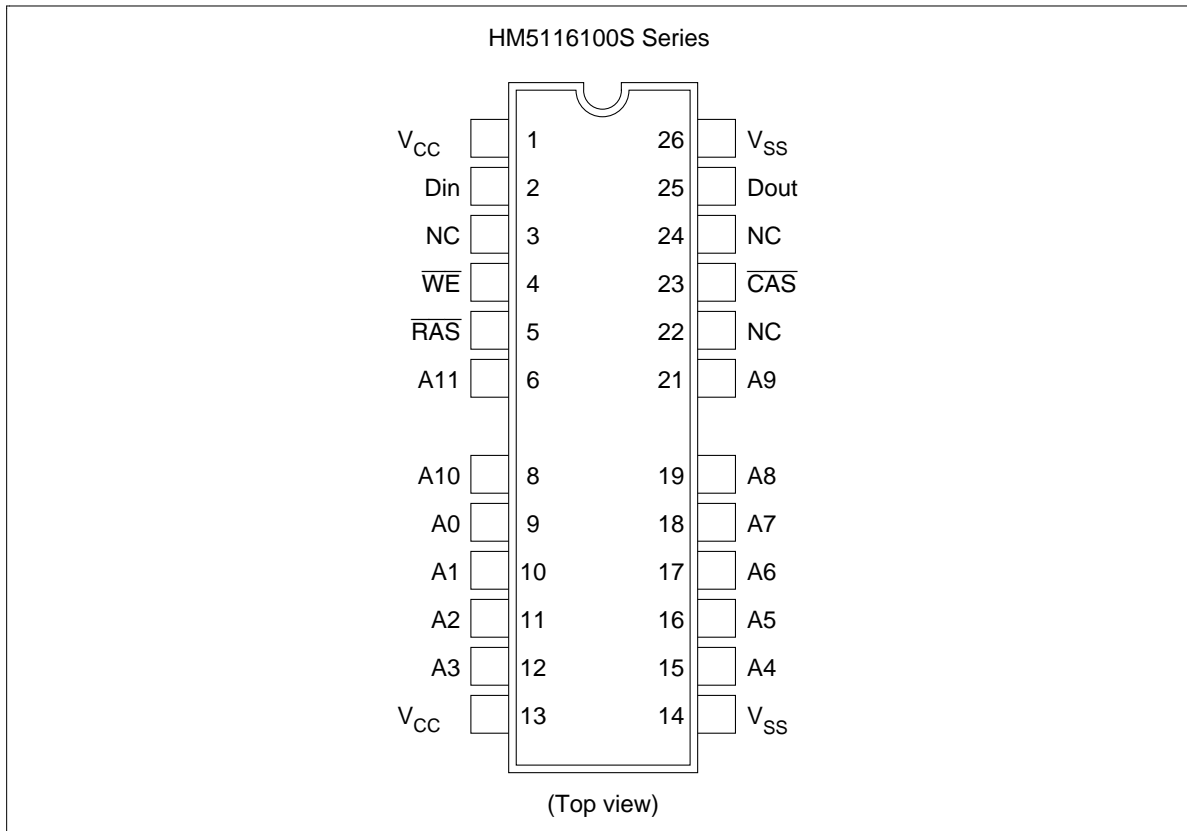

Pin Description

Pin name	Function
A0 to A11	Address input <ul style="list-style-type: none"> • Row/Refresh A0 to A11 • Column A0 to A11
Din	Data input
Dout	Data output
$\overline{\text{RAS}}$	Row address strobe
$\overline{\text{CAS}}$	Column address strobe
$\overline{\text{WE}}$	Read/write enable
V_{CC}	Power supply
V_{SS}	Ground
NC	No connection

Block Diagram

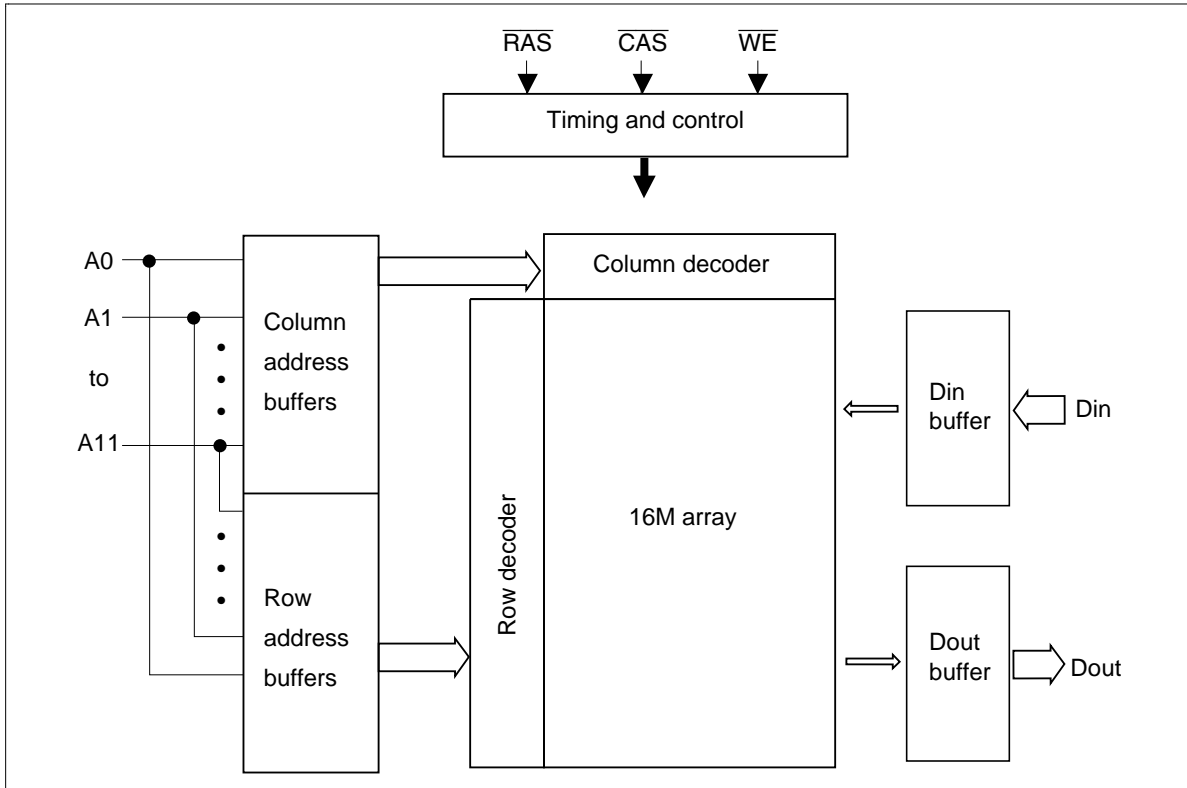

HM5116100 Series

Absolute Maximum Ratings

Parameter	Symbol	Value	Unit
Voltage on any pin relative to V_{SS}	V_T	-1.0 to +7.0	V
Supply voltage relative to V_{SS}	V_{CC}	-1.0 to +7.0	V
Short circuit output current	I_{out}	50	mA
Power dissipation	P_T	1.0	W
Operating temperature	T_{opr}	0 to +70	°C
Storage temperature	T_{stg}	-55 to +125	°C

Recommended DC Operating Conditions ($T_a = 0$ to +70°C)

Parameter	Symbol	Min	Typ	Max	Unit	Note
Supply voltage	V_{CC}	4.5	5.0	5.5	V	1
Input high voltage	V_{IH}	2.4	—	6.5	V	1
Input low voltage	V_{IL}	-1.0	—	0.8	V	1

Note: 1. All voltage referred to V_{SS}

HM5116100 Series

DC Characteristics ($T_a = 0$ to $+70^\circ\text{C}$, $V_{CC} = 5\text{ V} \pm 10\%$, $V_{SS} = 0\text{ V}$)

Parameter	Symbol	HM5116100				Unit	Test conditions
		-6		-7			
		Min	Max	Min	Max		
Operating current ^{*1,*2}	I_{CC1}	—	80	—	70	mA	$t_{RC} = \text{min}$
Standby current	I_{CC2}	—	2	—	2	mA	TTL interface $\overline{\text{RAS}}, \overline{\text{CAS}} = V_{IH}$ Dout = High-Z
		—	1	—	1	mA	CMOS interface $\overline{\text{RAS}}, \overline{\text{CAS}} \geq V_{CC} - 0.2\text{V}$ Dout = High-Z
$\overline{\text{RAS}}$ -only refresh current ^{*2}	I_{CC3}	—	80	—	70	mA	$t_{RC} = \text{min}$
Standby current ^{*1}	I_{CC5}	—	5	—	5	mA	$\overline{\text{RAS}} = V_{IH}, \overline{\text{CAS}} = V_{IL}$ Dout = enable
$\overline{\text{CAS}}$ -before- $\overline{\text{RAS}}$ refresh current	I_{CC6}	—	80	—	70	mA	$t_{RC} = \text{min}$
Fast page mode current ^{*1,*3}	I_{CC7}	—	70	—	60	mA	$t_{PC} = \text{min}$
Input leakage current	I_{LI}	-10	10	-10	10	μA	$0\text{ V} \leq V_{in} \leq 7\text{ V}$
Output leakage current	I_{LO}	-10	10	-10	10	μA	$0\text{ V} \leq V_{out} \leq 7\text{ V}$ Dout = disable
Output high voltage	V_{OH}	2.4	V_{CC}	2.4	V_{CC}	V	High Iout = -5 mA
Output low voltage	V_{OL}	0	0.4	0	0.4	V	Low Iout = 4.2 mA

Notes: 1. I_{CC} depends on output load condition when the device is selected. I_{CC} max is specified at the output open condition.

2. Address can be changed once or less while $\overline{\text{RAS}} = V_{IL}$.

3. Address can be changed once or less while $\overline{\text{CAS}} = V_{IH}$.

Capacitance ($T_a = 25^\circ\text{C}$, $V_{CC} = 5\text{ V} \pm 10\%$)

Parameter	Symbol	Typ	Max	Unit	Notes
Input capacitance (Address, Data-in)	C_{I1}	—	5	pF	1
Input capacitance (Clocks)	C_{I2}	—	7	pF	1
Output capacitance (Data-out)	C_O	—	7	pF	1, 2

Notes: 1. Capacitance measured with Booton Meter or effective capacitance measuring method.

2. $\overline{\text{CAS}} = V_{IH}$ to disable Dout.

HM5116100 Series

AC Characteristics ($T_a = 0$ to $+70^\circ\text{C}$, $V_{CC} = 5\text{ V} \pm 10\%$, $V_{SS} = 0\text{ V}$)^{*1, *2, *16}

Test Conditions

- Input rise and fall time : 5 ns
- Input timing reference levels : 0.8 V, 2.4 V
- Output load : 2 TTL gate + C_L (100 pF) (Including scope and jig)

Read, Write, Read-Modify-Write and Refresh Cycles (Common parameters)

Parameter	Symbol	HM5116100				Unit	Notes
		-6		-7			
		Min	Max	Min	Max		
Random read or write cycle time	t_{RC}	110	—	130	—	ns	
$\overline{\text{RAS}}$ precharge time	t_{RP}	40	—	50	—	ns	
$\overline{\text{CAS}}$ precharge time	t_{CP}	10	—	10	—	ns	
$\overline{\text{RAS}}$ pulse width	t_{RAS}	60	10000	70	10000	ns	
$\overline{\text{CAS}}$ pulse width	t_{CAS}	15	10000	18	10000	ns	
Row address setup time	t_{ASR}	0	—	0	—	ns	
Row address hold time	t_{RAH}	10	—	10	—	ns	
Column address setup time	t_{ASC}	0	—	0	—	ns	
Column address hold time	t_{CAH}	10	—	15	—	ns	
$\overline{\text{RAS}}$ to $\overline{\text{CAS}}$ delay time	t_{RCD}	20	45	20	52	ns	3
$\overline{\text{RAS}}$ to column address delay time	t_{RAD}	15	30	15	35	ns	4
$\overline{\text{RAS}}$ hold time	t_{RSH}	15	—	18	—	ns	
$\overline{\text{CAS}}$ hold time	t_{CSH}	60	—	70	—	ns	
$\overline{\text{CAS}}$ to $\overline{\text{RAS}}$ precharge time	t_{CRP}	5	—	5	—	ns	
Transition time (rise and fall)	t_T	3	50	3	50	ns	5

HM5116100 Series

Read Cycle

Parameter	Symbol	HM5116100				Unit	Notes
		-6		-7			
		Min	Max	Min	Max		
Access time from $\overline{\text{RAS}}$	t_{RAC}	—	60	—	70	ns	6, 7, 17
Access time from $\overline{\text{CAS}}$	t_{CAC}	—	15	—	18	ns	7, 8, 15, 17
Access time from address	t_{AA}	—	30	—	35	ns	7, 9, 15, 17
Read command setup time	t_{RCS}	0	—	0	—	ns	
Read command hold time to $\overline{\text{CAS}}$	t_{RCH}	0	—	0	—	ns	10
Read command hold time to $\overline{\text{RAS}}$	t_{RRH}	0	—	0	—	ns	10
Column address to $\overline{\text{RAS}}$ lead time	t_{RAL}	30	—	35	—	ns	
Column address to $\overline{\text{CAS}}$ lead time	t_{CAL}	30	—	35	—	ns	
$\overline{\text{CAS}}$ to output in low-Z	t_{CLZ}	0	—	0	—	ns	
Output data hold time	t_{OH}	3	—	3	—	ns	
Output buffer turn-off time	t_{OFF}	—	15	—	15	ns	11

Write Cycle

Parameter	Symbol	HM5116100				Unit	Notes
		-6		-7			
		Min	Max	Min	Max		
Write command setup time	t_{WCS}	0	—	0	—	ns	12
Write command hold time	t_{WCH}	10	—	15	—	ns	
Write command pulse width	t_{WP}	10	—	10	—	ns	
Write command to $\overline{\text{RAS}}$ lead time	t_{RWL}	15	—	18	—	ns	
Write command to $\overline{\text{CAS}}$ lead time	t_{CWL}	15	—	18	—	ns	
Data-in setup time	t_{DS}	0	—	0	—	ns	13
Data-in hold time	t_{DH}	10	—	15	—	ns	13

HM5116100 Series

Read-Modify-Write Cycle

Parameter	Symbol	HM5116100				Unit	Notes
		-6		-7			
		Min	Max	Min	Max		
Read-modify-write cycle time	t_{RWC}	130	—	153	—	ns	
RAS to \overline{WE} delay time	t_{RWD}	60	—	70	—	ns	12
CAS to \overline{WE} delay time	t_{CWD}	15	—	18	—	ns	12
Column address to \overline{WE} delay time	t_{AWD}	30	—	35	—	ns	12

Refresh Cycle

Parameter	Symbol	HM5116100				Unit	Notes
		-6		-7			
		Min	Max	Min	Max		
CAS setup time (CBR refresh cycle)	t_{CSR}	5	—	5	—	ns	
\overline{CAS} hold time (CBR refresh cycle)	t_{CHR}	10	—	10	—	ns	
\overline{WE} setup time (CBR refresh cycle)	t_{WRP}	0	—	0	—	ns	
\overline{WE} hold time (CBR refresh cycle)	t_{WRH}	10	—	10	—	ns	
RAS precharge to \overline{CAS} hold time	t_{RPC}	5	—	5	—	ns	

Fast Page Mode Cycle

Parameter	Symbol	HM5116100				Unit	Notes
		-6		-7			
		Min	Max	Min	Max		
Fast page mode cycle time	t_{PC}	40	—	45	—	ns	
Fast page mode \overline{RAS} pulse width	t_{RASP}	—	100000	—	100000	ns	14
Access time from \overline{CAS} precharge	t_{CPA}	—	35	—	40	ns	7, 15, 17
\overline{RAS} hold time from \overline{CAS} precharge	t_{CPRH}	35	—	40	—	ns	

HM5116100 Series

Fast Page Mode Read-Modify-Write Cycle

Parameter	Symbol	HM5116100				Unit	Notes
		-6		-7			
		Min	Max	Min	Max		
Fast page mode read-modify-write cycle time	t_{PRWC}	60	—	68	—	ns	
\overline{WE} delay time from \overline{CAS} precharge	t_{CPW}	35	—	40	—	ns	12

Test Mode Cycle *16

Parameter	Symbol	HM5116100				Unit	Notes
		-6		-7			
		Min	Max	Min	Max		
Test mode \overline{WE} setup time	t_{WTS}	0	—	0	—	ns	
Test mode \overline{WE} hold time	t_{WTH}	10	—	10	—	ns	

Refresh Cycle

Parameter	Symbol	Max	Unit	Note
Refresh period	t_{REF}	64	ms	4096 cycles

HM5116100 Series

- Notes:
1. AC measurements assume $t_r = 5$ ns.
 2. An initial pause of 200 μ s is required after power up followed by a minimum of eight initialization cycles (any combination of cycles containing $\overline{\text{RAS}}$ -only refresh or $\overline{\text{CAS}}$ -before- $\overline{\text{RAS}}$ refresh). If the internal refresh counter is used, a minimum of eight $\overline{\text{CAS}}$ -before- $\overline{\text{RAS}}$ refresh cycles are required.
 3. Operation with the t_{RCD} (max) limit insures that t_{RAC} (max) can be met, t_{RCD} (max) is specified as a reference point only; if t_{RCD} is greater than the specified t_{RCD} (max) limit, then access time is controlled exclusively by t_{CAC} .
 4. Operation with the t_{RAD} (max) limit insures that t_{RAC} (max) can be met, t_{RAD} (max) is specified as a reference point only; if t_{RAD} is greater than the specified t_{RAD} (max) limit, then access time is controlled exclusively by t_{AA} .
 5. V_{IH} (min) and V_{IL} (max) are reference levels for measuring timing of input signals. Also, transition times are measured between V_{IH} (min) and V_{IL} (max).
 6. Assume that $t_{\text{RCD}} \leq t_{\text{RCD}}$ (max) and $t_{\text{RAD}} \leq t_{\text{RAD}}$ (max). If t_{RCD} or t_{RAD} is greater than the maximum recommended value shown in this table, t_{RAC} exceeds the value shown.
 7. Measured with a load circuit equivalent to 2 TTL loads and 100 pF.
 8. Assume that $t_{\text{RCD}} \geq t_{\text{RCD}}$ (max) and $t_{\text{RAD}} \leq t_{\text{RAD}}$ (max).
 9. Assume that $t_{\text{RCD}} \leq t_{\text{RCD}}$ (max) and $t_{\text{RAD}} \geq t_{\text{RAD}}$ (max).
 10. Either t_{RCH} or t_{RRH} must be satisfied for a read cycles.
 11. t_{OFF} (max) and t_{OEZ} (max) define the time at which the outputs achieve the open circuit condition and are not referred to output voltage levels.
 12. t_{WCS} , t_{RWD} , t_{CWD} , t_{AWD} and t_{CPW} are not restrictive operating parameters. They are included in the data sheet as electrical characteristics only; if $t_{\text{WCS}} \geq t_{\text{WCS}}$ (min), the cycle is an early write cycle and the data out pin will remain open circuit (high impedance) throughout the entire cycle; if $t_{\text{RWD}} \geq t_{\text{RWD}}$ (min), $t_{\text{CWD}} \geq t_{\text{CWD}}$ (min), and $t_{\text{AWD}} \geq t_{\text{AWD}}$ (min), or $t_{\text{CWD}} \geq t_{\text{CWD}}$ (min), $t_{\text{AWD}} \geq t_{\text{AWD}}$ (min) and $t_{\text{CPW}} \geq t_{\text{CPW}}$ (min), the cycle is a read-modify-write and the data output will contain data read from the selected cell; if neither of the above sets of conditions is satisfied, the condition of the data out (at access time) is indeterminate.
 13. These parameters are referenced to $\overline{\text{CAS}}$ leading edge in early write cycles and to $\overline{\text{WE}}$ leading edge in delayed write or read-modify-write cycles.
 14. t_{RASP} defines $\overline{\text{RAS}}$ pulse width in fast page mode cycles.
 15. Access time is determined by the longest among t_{AA} , t_{CAC} and t_{CPA} .
 16. The 16M DRAM offers a 16-bit time saving parallel test mode. Address CA0, CA1, CA10 and CA11 for the $16\text{M} \times 1$ are don't care during test mode. Test mode is set by performing a $\overline{\text{WE}}$ -and- $\overline{\text{CAS}}$ -before- $\overline{\text{RAS}}$ (WCBR) cycle. In 16-bit parallel test mode, data is written into 16 bits in parallel at Din and read out from Dout.
If 16 bits are equal (all 1s or 0s), data output pin is a high state during test mode read cycle, then the device has passed. If they are not equal, data output pin is a low state, then the device has failed. Refresh during test mode operation can be performed by normal read cycles or by WCBR refresh cycles.
To get out of test mode and enter a normal operation mode, perform either a regular $\overline{\text{CAS}}$ -before- $\overline{\text{RAS}}$ refresh cycle or $\overline{\text{RAS}}$ -only refresh cycle.
 17. In a test mode read cycle, the value of t_{RAC} , t_{AA} , t_{CAC} and t_{CPA} is delayed by 2 ns to 5 ns for the specified value. These parameters should be specified in test mode cycles by adding the above value to the specified value in this data sheet.
 18. XXX: H or L (H: V_{IH} (min) $\leq V_{\text{IN}} \leq V_{\text{IH}}$ (max), L: V_{IL} (min) $\leq V_{\text{IN}} \leq V_{\text{IL}}$ (max))
/////: Invalid Dout

Timing Waveforms *18

Read Cycle

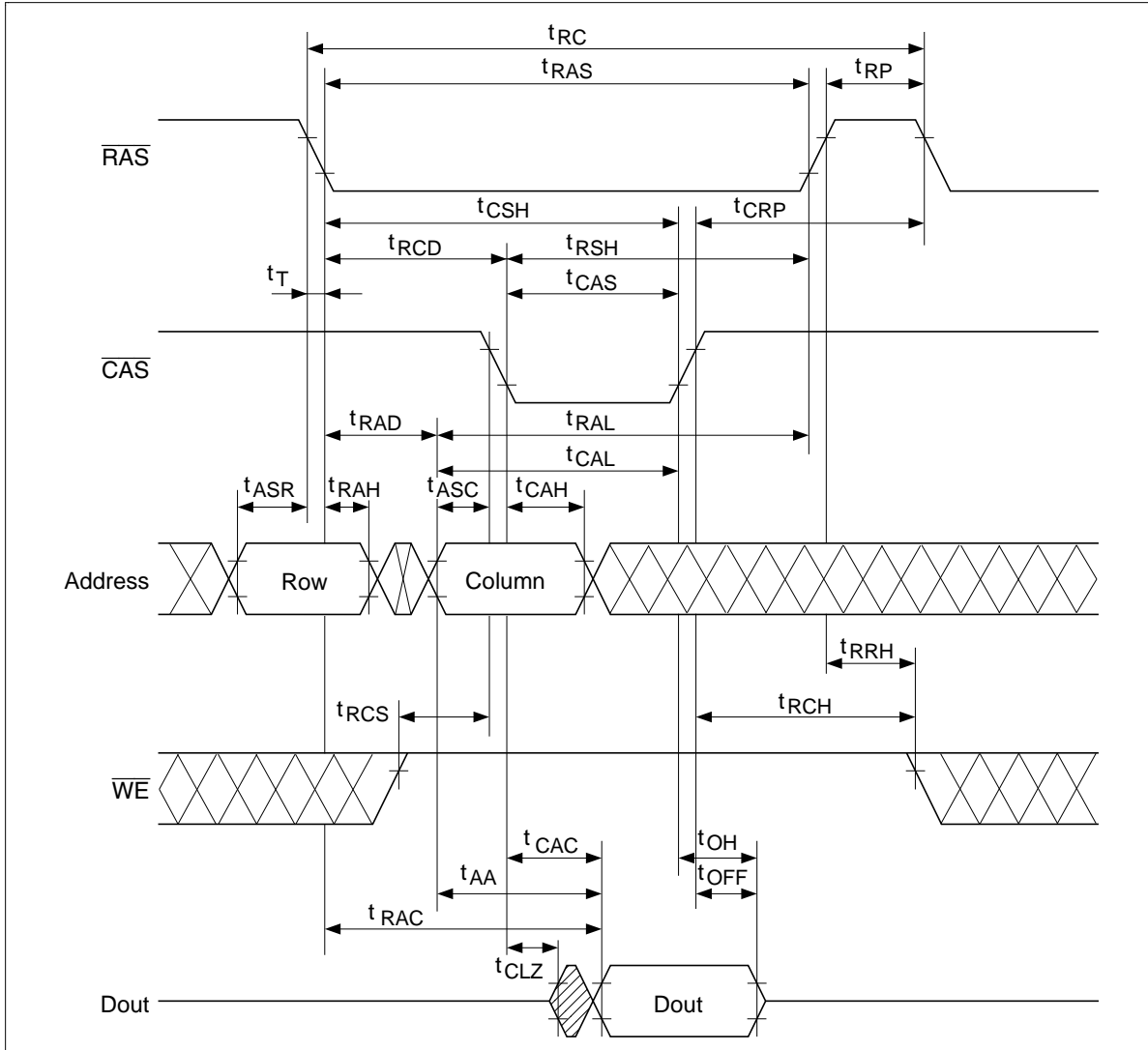

HM5116100 Series

Early Write Cycle

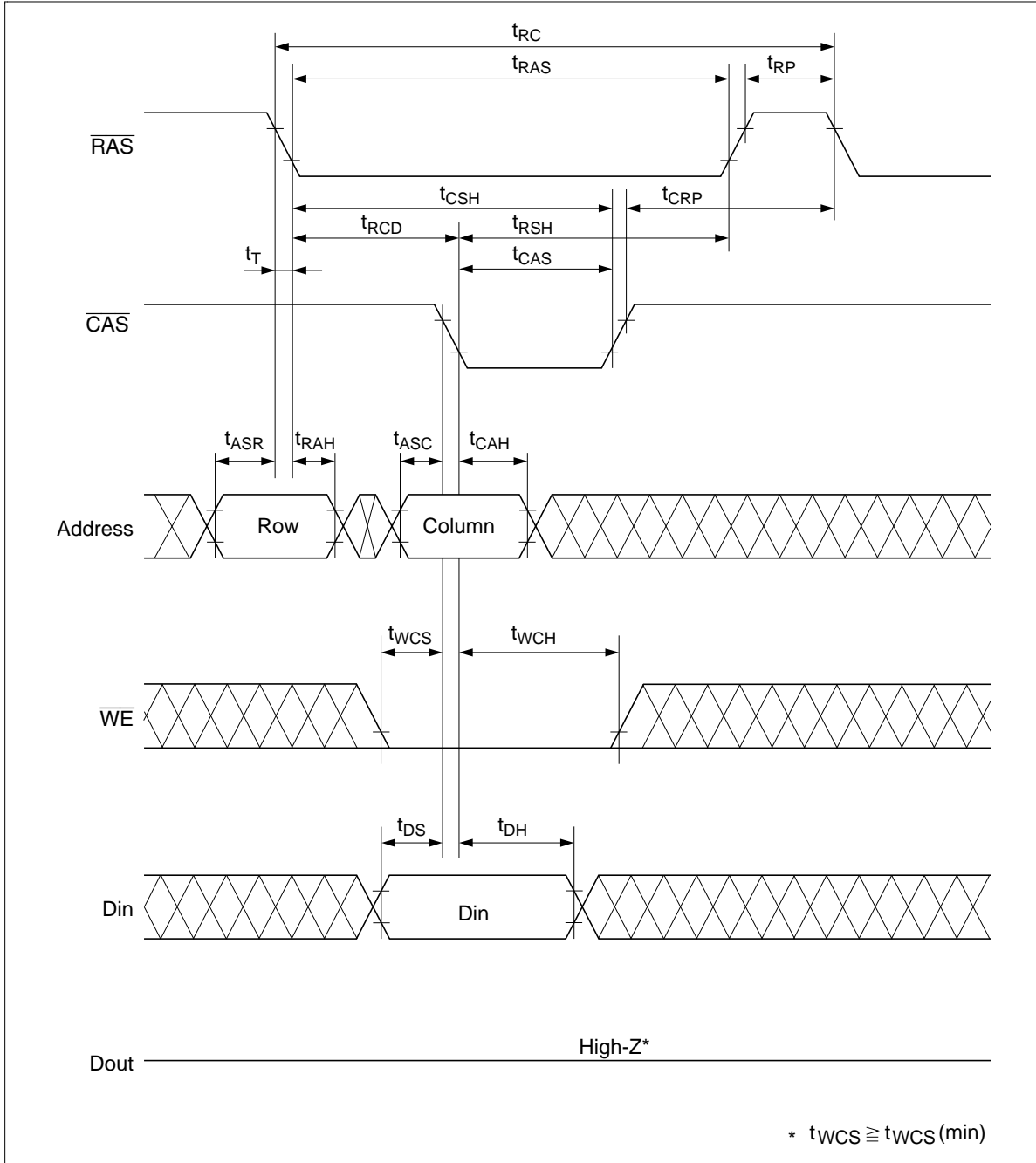

Delayed Write Cycle

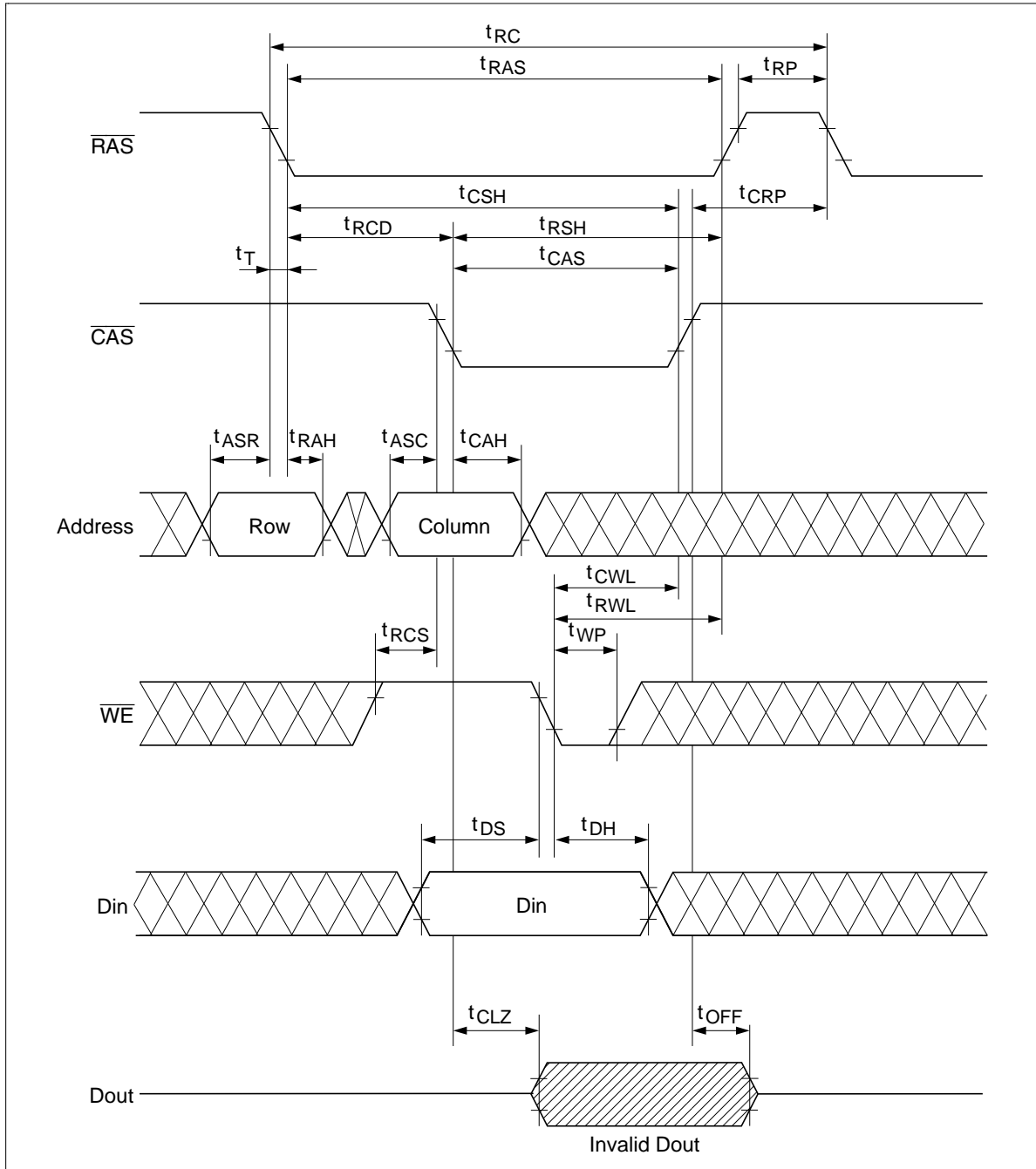

HM5116100 Series

Read-Modify-Write Cycle

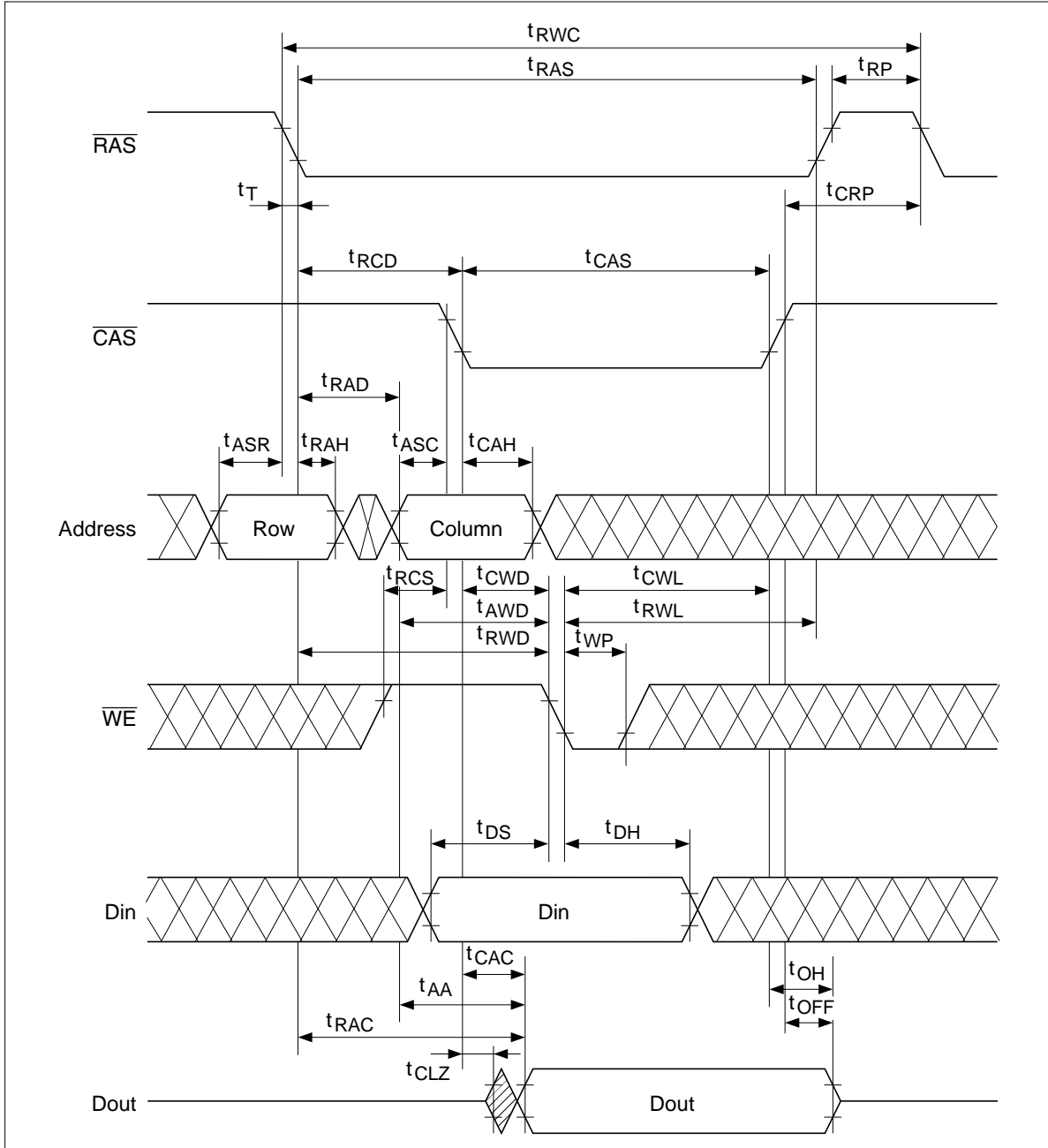

$\overline{\text{RAS}}$ -Only Refresh Cycle

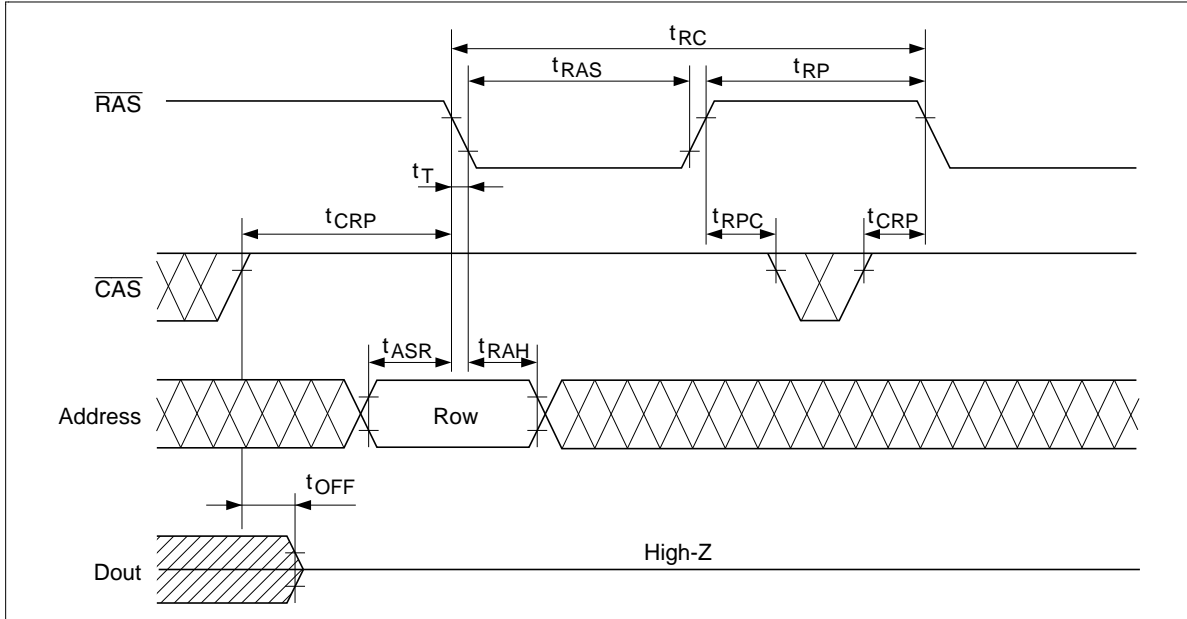

$\overline{\text{CAS}}$ -Before- $\overline{\text{RAS}}$ Refresh Cycle

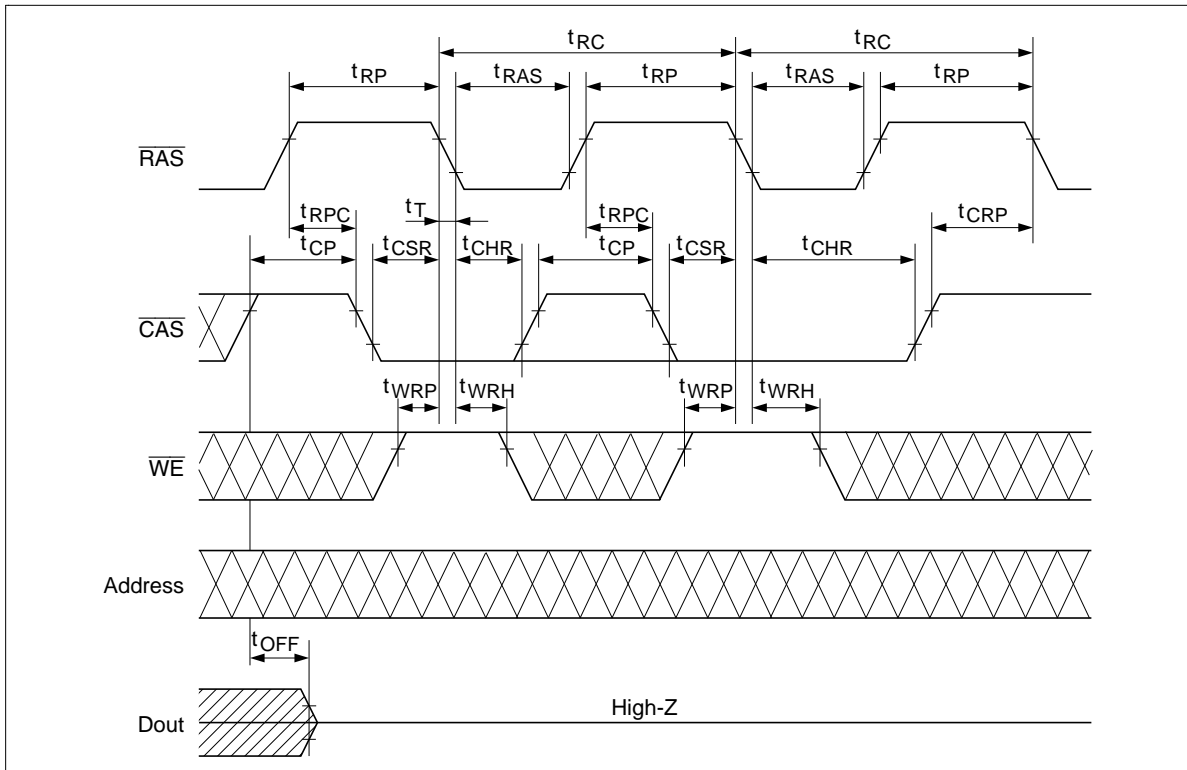

HM5116100 Series

Hidden Refresh Cycle

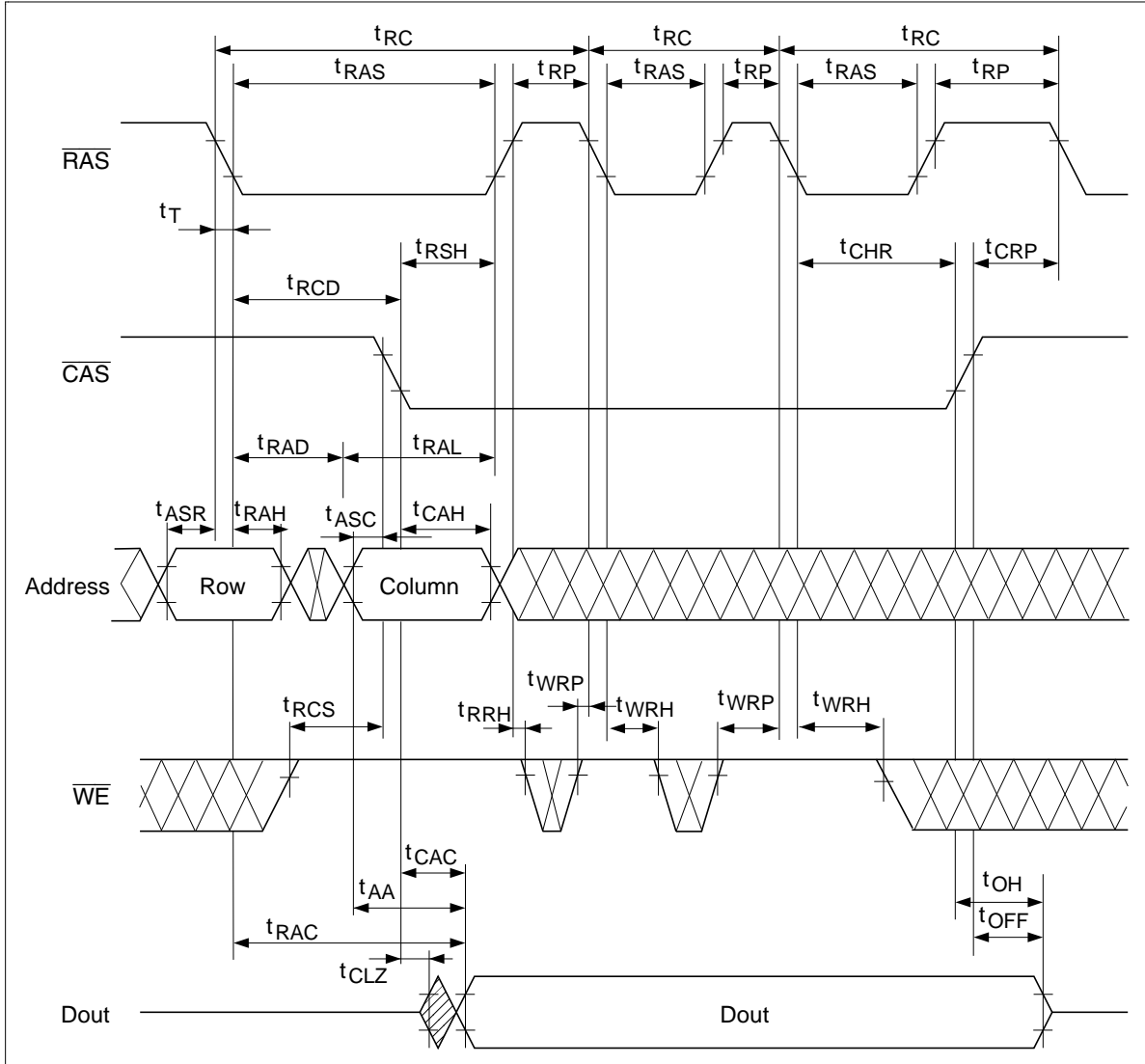

Fast Page Mode Read Cycle

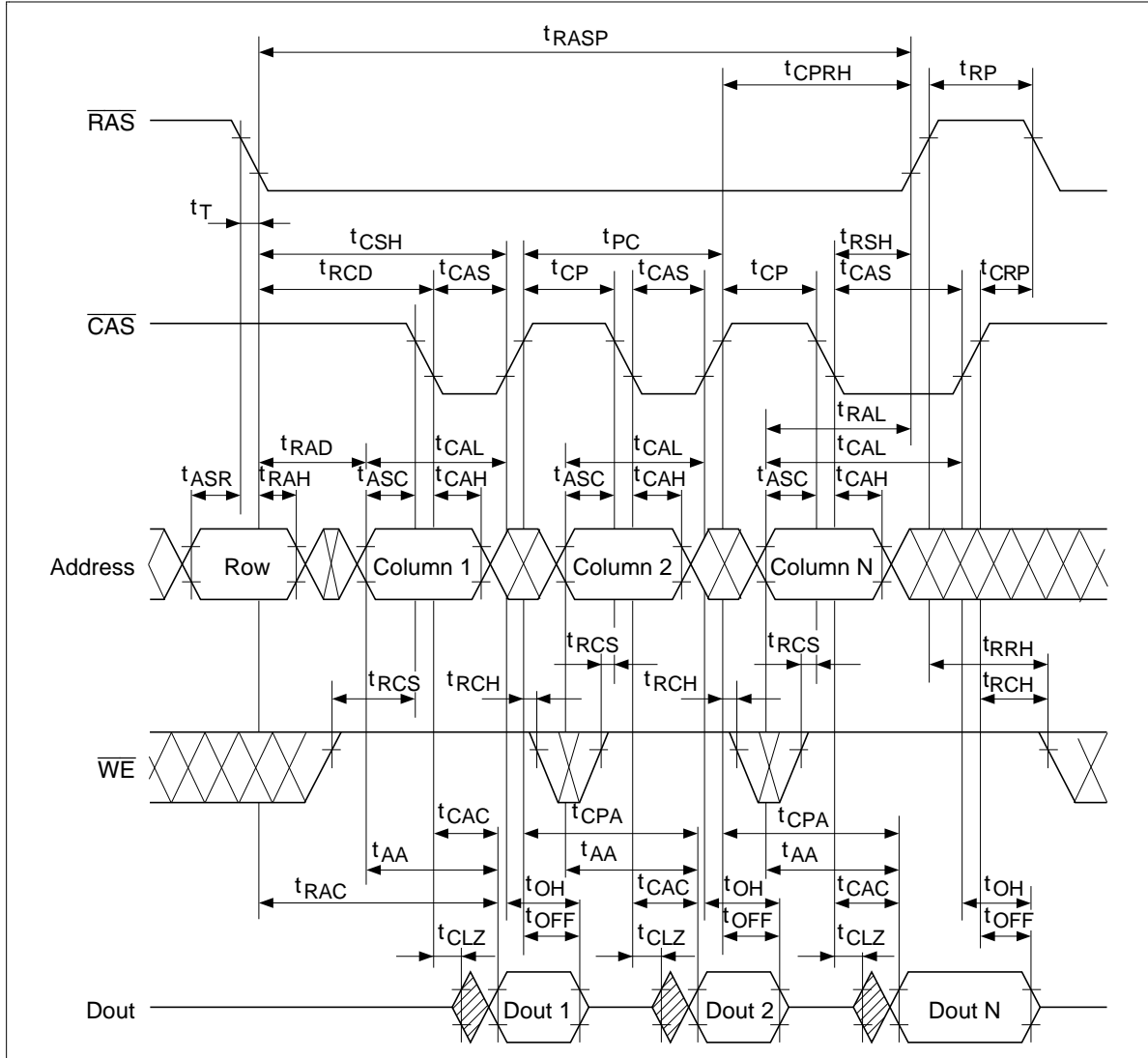

HM5116100 Series

Fast Page Mode Early Write Cycle

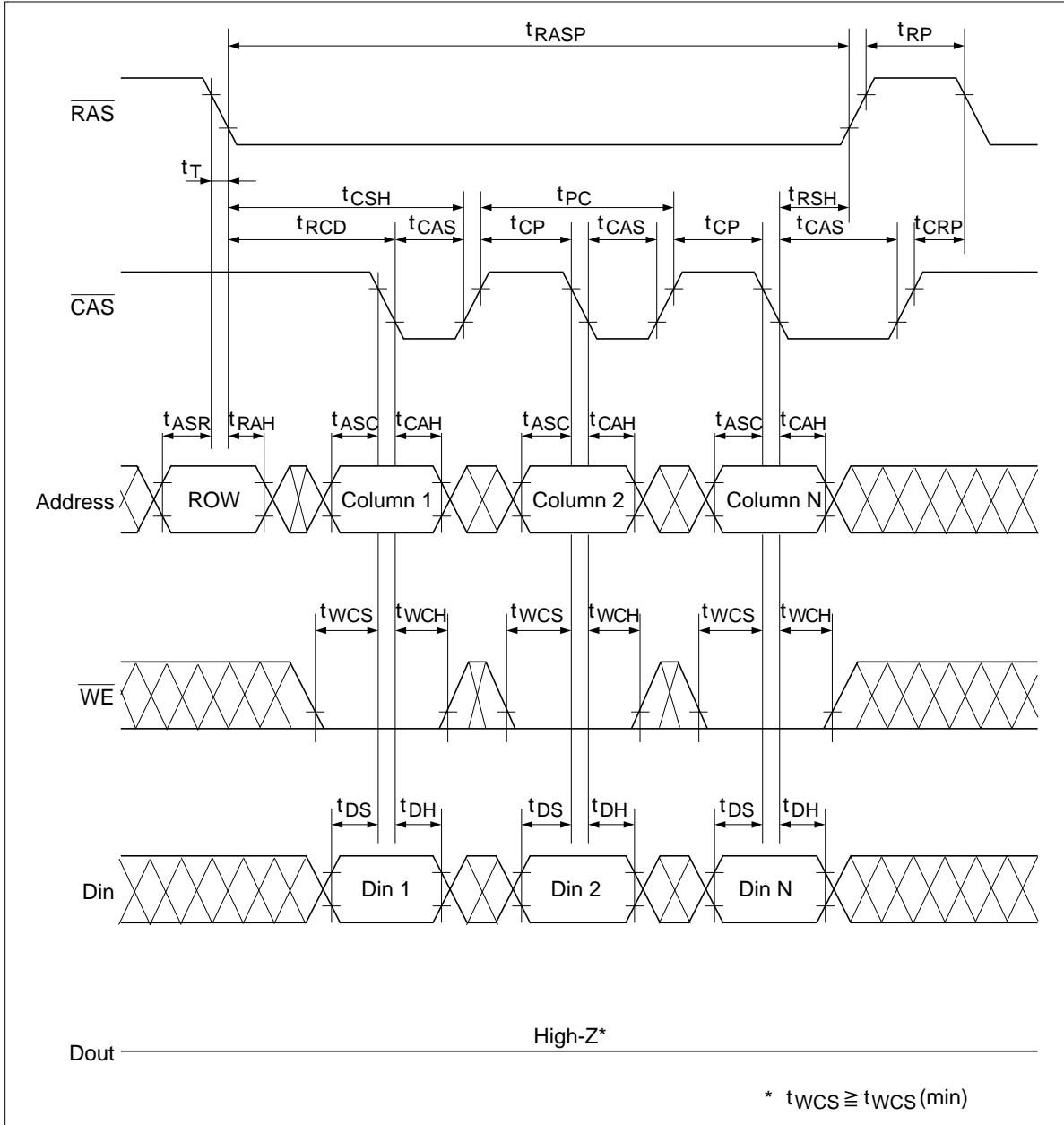

Fast Page Mode Delayed Write Cycle

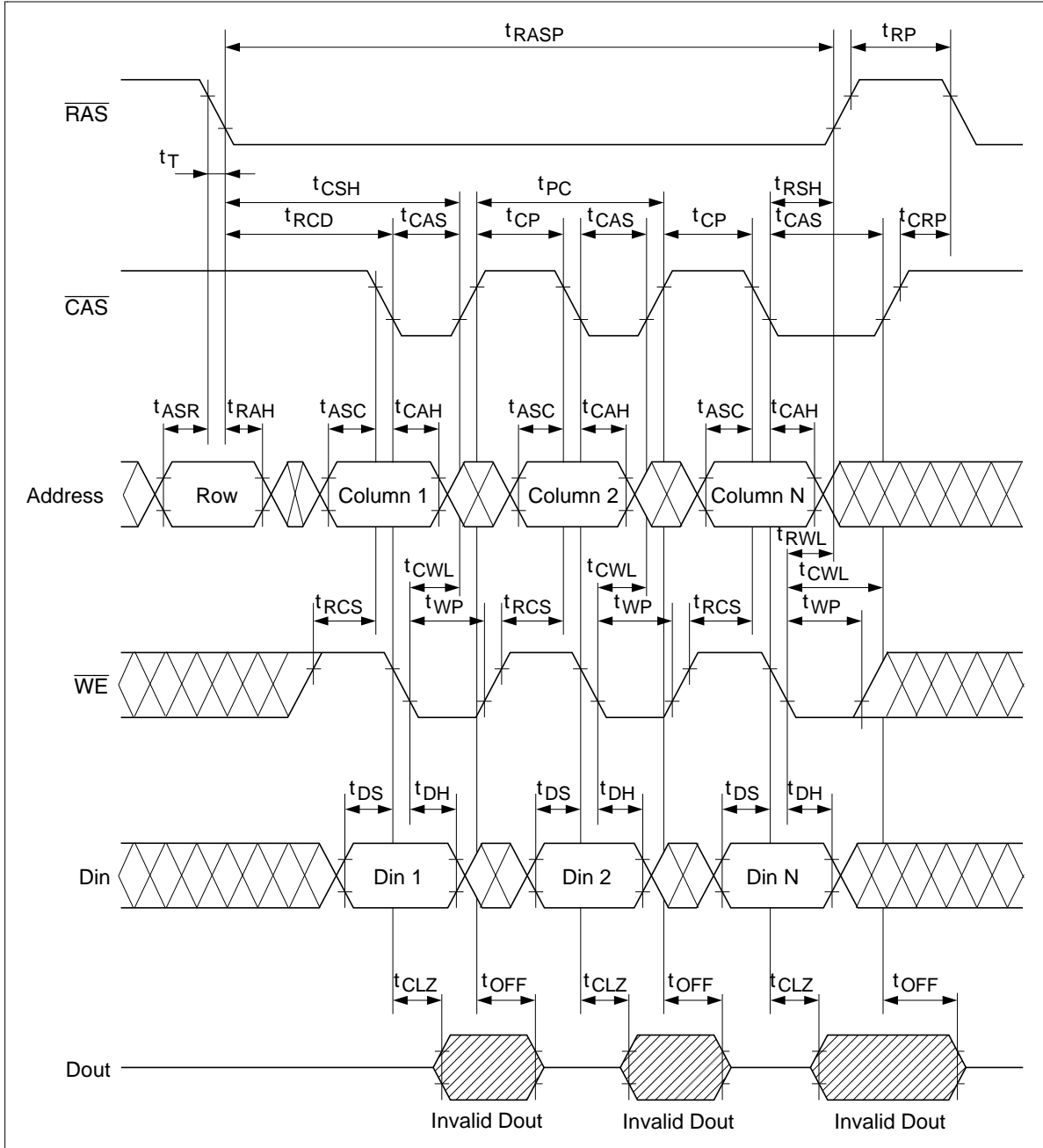

Test Mode Cycle*¹⁶

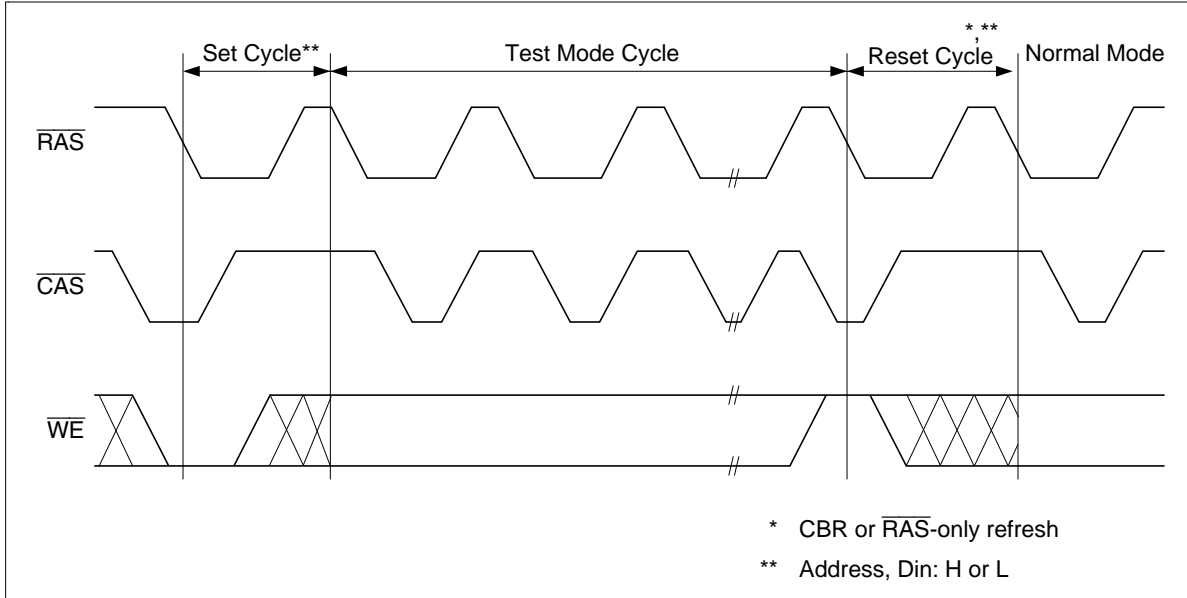

Test Mode Set Cycle

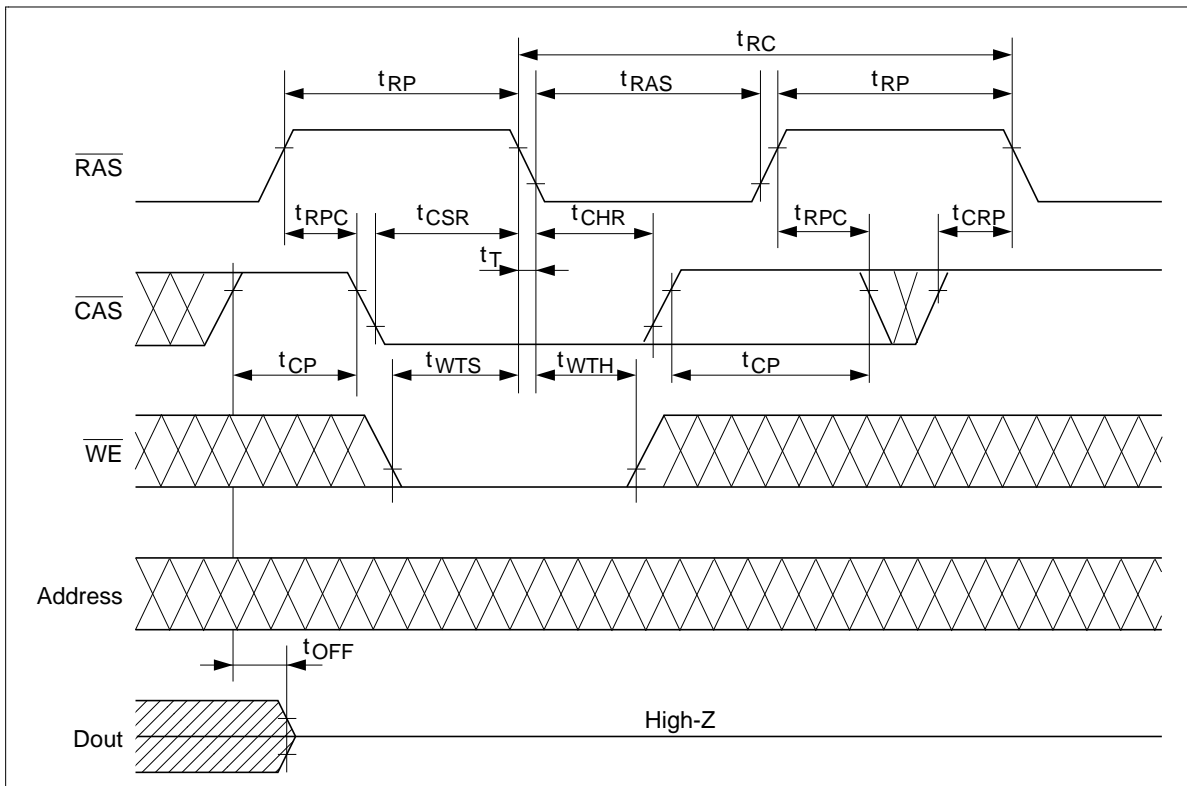

HM5116100 Series

Package Dimensions

HM5116100S Series (CP-26/24DB)

Unit: mm

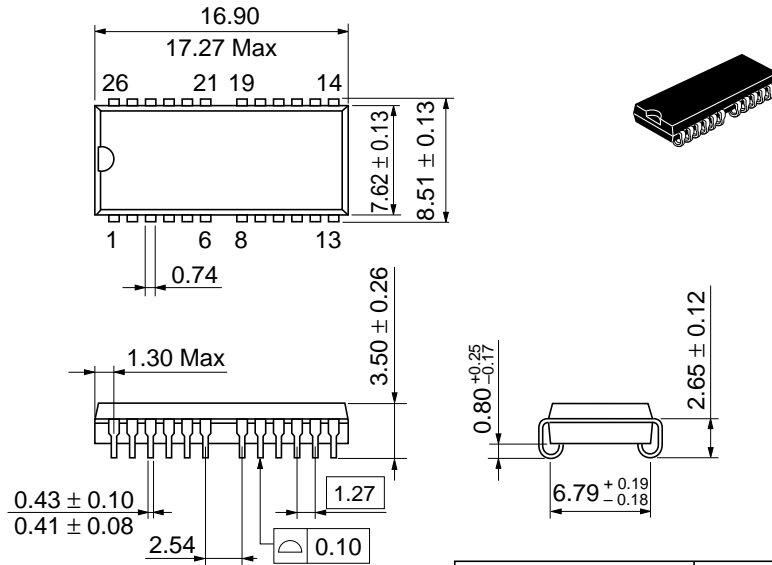

Dimension including the plating thickness
Base material dimension

Hitachi Code	CP-26/24DB
JEDEC	Conforms
EIAJ	Conforms
Weight (reference value)	0.8 g

When using this document, keep the following in mind:

1. This document may, wholly or partially, be subject to change without notice.
2. All rights are reserved: No one is permitted to reproduce or duplicate, in any form, the whole or part of this document without Hitachi's permission.
3. Hitachi will not be held responsible for any damage to the user that may result from accidents or any other reasons during operation of the user's unit according to this document.
4. Circuitry and other examples described herein are meant merely to indicate the characteristics and performance of Hitachi's semiconductor products. Hitachi assumes no responsibility for any intellectual property claims or other problems that may result from applications based on the examples described herein.
5. No license is granted by implication or otherwise under any patents or other rights of any third party or Hitachi, Ltd.
6. **MEDICAL APPLICATIONS:** Hitachi's products are not authorized for use in **MEDICAL APPLICATIONS** without the written consent of the appropriate officer of Hitachi's sales company. Such use includes, but is not limited to, use in life support systems. Buyers of Hitachi's products are requested to notify the relevant Hitachi sales offices when planning to use the products in **MEDICAL APPLICATIONS**.

HITACHI

Hitachi, Ltd.

Semiconductor & IC Div.
Nippon Bldg., 2-6-2, Ohte-machi, Chiyoda-ku, Tokyo 100, Japan
Tel: Tokyo (03) 3270-2111
Fax: (03) 3270-5109

For further information write to:

Hitachi Semiconductor
(America) Inc.
2000 Sierra Point Parkway
Brisbane, CA. 94005-1897
U S A
Tel: 800-285-1601
Fax: 303-297-0447

Hitachi Europe GmbH
Continental Europe
Dornacher Straße 3
D-85622 Feldkirchen
München
Tel: 089-9 91 80-0
Fax: 089-9 29 30-00

Hitachi Europe Ltd.
Electronic Components Div.
Northern Europe Headquarters
Whitebrook Park
Lower Cookham Road
Maidenhead
Berkshire SL6 8YA
United Kingdom
Tel: 01628-585000
Fax: 01628-585160

Hitachi Asia Pte. Ltd.
16 Collyer Quay #20-00
Hitachi Tower
Singapore 049318
Tel: 535-2100
Fax: 535-1533

Hitachi Asia (Hong Kong) Ltd.
Unit 706, North Tower,
World Finance Centre,
Harbour City, Canton Road
Tsim Sha Tsui, Kowloon
Hong Kong
Tel: 27359218
Fax: 27306071

Copyright © Hitachi, Ltd., 1997. All rights reserved. Printed in Japan.

HM5116100 Series

Revision Record

Rev.	Date	Contents of Modification	Drawn by	Approved by
1.0	Oct. 14, 1996	Initial issue	Y. Kasama	M. Mishima
2.0	Dec. 10, 1996	Addition of HM5116100-5 Series	Y. Kasama	Y. Matsuno
3.0	Feb. 27, 1997	AC Characteristics t_{RRH} min: 5/5/5 ns to 0/0/0 ns	Y. Kasama	Y. Matsuno
4.0	Jun. 24, 1997	Deletion of HM5116100-5 Series	Y. Kasama	Y. Matsuno
5.0	Nov. 1997	Change of Subtitle		