

Smart Sense High-Side Power Switch

Features

- Short circuit protection
- Current limitation
- Proportional load current sense
- CMOS compatible input
- Open drain diagnostic output
- Fast demagnetization of inductive loads
- Undervoltage and overvoltage shutdown with auto-restart and hysteresis
- Overload protection
- Thermal shutdown
- Overvoltage protection including load dump (with external GND-resistor)
- Reverse battery protection (with external GND-resistor)
- Loss of ground and loss of V_{bb} protection
- Electrostatic discharge (ESD) protection

Product Summary

Operating voltage	$V_{bb(on)}$	5.0 ... 34	V
On-state resistance	R_{ON}	30	m Ω
Load current (ISO)	$I_{L(ISO)}$	12.6	A
Current limitation	$I_{L(SCr)}$	24	A

Package

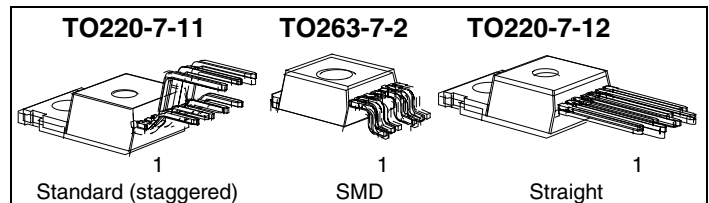

Application

- μ C compatible power switch with diagnostic feedback for 12 V and 24 V DC grounded loads
- All types of resistive, inductive and capacitive loads
- Replaces electromechanical relays, fuses and discrete circuits

General Description

N channel vertical power FET with charge pump, ground referenced CMOS compatible input and diagnostic feedback, proportional sense of load current, monolithically integrated in Smart SIMOS technology. Fully protected by embedded protection functions.

Block Diagram

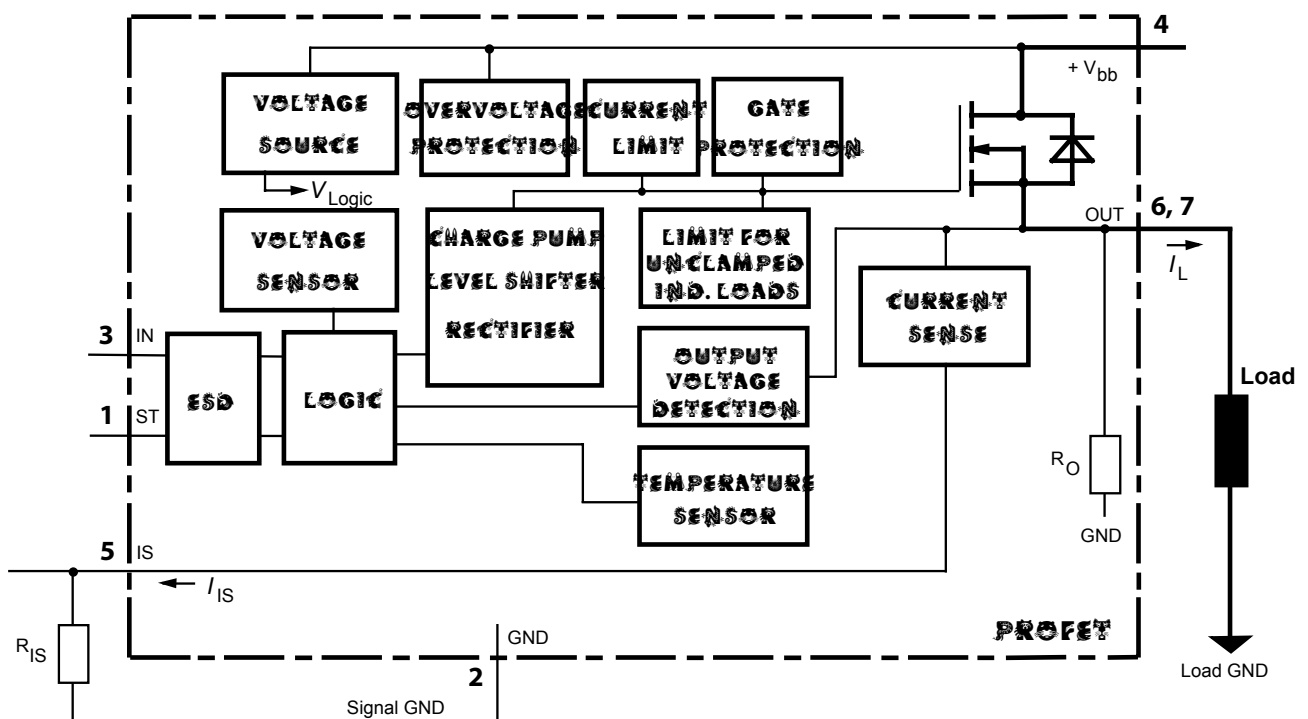

Pin	Symbol	Function
1	ST	Diagnostic feedback: open drain, invers to input level
2	GND	Logic ground
3	IN	Input, activates the power switch in case of logical high signal
4	V _{bb}	Positive power supply voltage, the tab is shorted to this pin
5	IS	Sense current output, proportional to the load current, zero in the case of current limitation of load current
6 & 7	OUT (Load, L)	Output, protected high-side power output to the load. Both output pins have to be connected in parallel for operation according this spec (e.g. k_{ILIS}). Design the wiring for the max. short circuit current

Maximum Ratings at $T_j = 25\text{ °C}$ unless otherwise specified

Parameter	Symbol	Values	Unit
Supply voltage (overvoltage protection see page 4)	V_{bb}	43	V
Supply voltage for full short circuit protection $T_j \text{ Start} = -40 \dots +150\text{ °C}$	V_{bb}	34	V
Load dump protection ¹⁾ $V_{\text{Load Dump}} = V_A + V_S$, $V_A = 13.5\text{V}$ $R_1^2) = 2\ \Omega$, $R_L = 1\ \Omega$, $t_d = 200\text{ ms}$, IN= low or high	$V_{\text{Load dump}}^3)$	60	V
Load current (Short circuit current, see page 5)	I_L	self-limited	A
Operating temperature range	T_j	-40 ... +150	°C
Storage temperature range	T_{stg}	-55 ... +150	
Power dissipation (DC), $T_C \leq 25\text{ °C}$	P_{tot}	85	W
Inductive load switch-off energy dissipation, single pulse $V_{bb} = 12\text{V}$, $T_{j,\text{start}} = 150\text{ °C}$, $T_C = 150\text{ °C}$ const. $I_L = 12.6\text{ A}$, $Z_L = 4,2\text{ mH}$, $0\ \Omega$: $I_L = 4\text{ A}$, $Z_L = 330\text{ mH}$, $0\ \Omega$:	E_{AS} E_{AS}	0,41 3,5	J
Electrostatic discharge capability (ESD) (Human Body Model) acc. MIL-STD883D, method 3015.7 and ESD assn. std. S5.1-1993 $R = 1.5\text{k}\Omega$; $C = 100\text{pF}$	IN: ST, IS: out to all other pins shorted: V_{ESD}	1.0 4.0 8.0	kV
Input voltage (DC)	V_{IN}	-10 ... +16	V
Current through input pin (DC)	I_{IN}	± 2.0	mA
Current through status pin (DC)	I_{ST}	± 5.0	
Current through current sense pin (DC) see internal circuit diagrams page 9	I_{IS}	± 14	

1) Supply voltages higher than $V_{bb(AZ)}$ require an external current limit for the GND and status pins (a 150 Ω resistor in the GND connection is recommended).

2) R_1 = internal resistance of the load dump test pulse generator

3) $V_{\text{Load dump}}$ is setup without the DUT connected to the generator according to ISO 7637-1 and DIN 40839

Thermal Characteristics

Parameter and Conditions	Symbol	Values			Unit
		min	typ	max	
Thermal resistance chip - case:	R_{thJC}	--	--	1.47	K/W
junction - ambient (free air):	R_{thJA}	--	--	75	
SMD version, device on PCB ⁴⁾ :		--	33	--	

Electrical Characteristics

Parameter and Conditions at $T_j = 25\text{ °C}$, $V_{bb} = 12\text{ V}$ unless otherwise specified	Symbol	Values			Unit
		min	typ	max	

Load Switching Capabilities and Characteristics

On-state resistance (pin 4 to 6&7) $I_L = 5\text{ A}$ $T_j = 25\text{ °C}$: $T_j = 150\text{ °C}$:	R_{ON}	--	27 54	30 60	m Ω
Output voltage drop limitation at small load currents (pin 4 to 6&7), see page 15 $I_L = 0.5\text{ A}$ $T_j = -40\dots+150\text{ °C}$:	$V_{ON(NL)}$	--	50	--	mV
Nominal load current, ISO Norm (pin 4 to 6&7) $V_{ON} = 0.5\text{ V}$, $T_C = 85\text{ °C}$	$I_{L(ISO)}$	11.4	12.6	--	A
Nominal load current, device on PCB ⁴⁾ $T_A = 85\text{ °C}$, $T_j \leq 150\text{ °C}$ $V_{ON} \leq 0.5\text{ V}$,	$I_{L(NOM)}$	4.0	4.5	--	A
Output current (pin 6&7) while GND disconnected or GND pulled up, $V_{bb} = 30\text{ V}$, $V_{IN} = 0$, see diagram page 10; not tested, specified by design	$I_{L(GNDhigh)}$	--	--	8	mA
Turn-on time Turn-off time $R_L = 12\text{ }\Omega$, $T_j = -40\dots+150\text{ °C}$	t_{on} t_{off}	25 25	70 80	150 200	μs
Slew rate on 10 to 30% V_{OUT} , $R_L = 12\text{ }\Omega$, $T_j = -40\dots+150\text{ °C}$	dV/dt_{on}	0.1	--	1	V/ μs
Slew rate off 70 to 40% V_{OUT} , $R_L = 12\text{ }\Omega$, $T_j = -40\dots+150\text{ °C}$	$-dV/dt_{off}$	0.1	--	1	V/ μs

⁴⁾ Device on 50mm*50mm*1.5mm epoxy PCB FR4 with 6cm² (one layer, 70 μm thick) copper area for V_{bb} connection. PCB is vertical without blown air.

Parameter and Conditions at $T_j = 25\text{ °C}$, $V_{bb} = 12\text{ V}$ unless otherwise specified	Symbol	Values			Unit
		min	typ	max	
Operating Parameters					
Operating voltage ⁵⁾	$T_j = -40\dots+150\text{ °C}$: $V_{bb(on)}$	5.0	--	34	V
Undervoltage shutdown	$T_j = -40\dots+150\text{ °C}$: $V_{bb(under)}$	3.2	--	5.0	V
Undervoltage restart	$T_j = -40\dots+25\text{ °C}$: $V_{bb(u\text{ rst})}$ $T_j = +150\text{ °C}$:	--	4.5	5.5 6.0	V
Undervoltage restart of charge pump see diagram page 14	$T_j = -40\dots+25\text{ °C}$: $V_{bb(ucp)}$ $T_j = 25\dots150\text{ °C}$:	--	4.7 --	6.5 7.0	V
Undervoltage hysteresis $\Delta V_{bb(under)} = V_{bb(u\text{ rst})} - V_{bb(under)}$	$\Delta V_{bb(under)}$	--	0.5	--	V
Overvoltage shutdown	$T_j = -40\dots+150\text{ °C}$: $V_{bb(over)}$	34	--	43	V
Overvoltage restart	$T_j = -40\dots+150\text{ °C}$: $V_{bb(o\text{ rst})}$	33	--	--	V
Overvoltage hysteresis	$T_j = -40\dots+150\text{ °C}$: $\Delta V_{bb(over)}$	--	1	--	V
Overvoltage protection ⁶⁾ $I_{bb} = 40\text{ mA}$	$T_j = -40\text{ °C}$: $V_{bb(AZ)}$ $T_j = +25\dots+150\text{ °C}$	41 43	-- 47	-- 52	V
Standby current (pin 4) $V_{IN} = 0$	$T_j = -40\dots+25\text{ °C}$: $I_{bb(off)}$ $T_j = 150\text{ °C}$:	--	4 12	15 25	μA
Off state output current (included in $I_{bb(off)}$) $V_{IN} = 0$,	$T_j = -40\dots+150\text{ °C}$: $I_{L(off)}$	--	--	10	μA
Operating current (Pin 2) ⁷⁾ , $V_{IN} = 5\text{ V}$	I_{GND}	--	1.2	3	mA

5) At supply voltage increase up to $V_{bb} = 4.7\text{ V}$ typ without charge pump, $V_{OUT} \approx V_{bb} - 2\text{ V}$

6) Supply voltages higher than $V_{bb(AZ)}$ require an external current limit for the GND and status pins (a $150\ \Omega$ resistor in the GND connection is recommended). See also $V_{ON(CL)}$ in table of protection functions and circuit diagram page 10.

7) Add I_{ST} , if $I_{ST} > 0$, add I_{IN} , if $V_{IN} > 5.5\text{ V}$

Parameter and Conditions at $T_j = 25\text{ °C}$, $V_{bb} = 12\text{ V}$ unless otherwise specified	Symbol	Values			Unit
		min	typ	max	
Protection Functions					
Initial peak short circuit current limit (pin 4 to 6&7) $T_i = -40\text{ °C}$: $T_i = 25\text{ °C}$: $T_j = +150\text{ °C}$:	$I_{L(SCp)}$	48 40 31	56 50 37	65 58 45	A
Repetitive short circuit shutdown current limit $T_j = T_{jt}$ (see timing diagrams, page 13)	$I_{L(SCr)}$	--	24	--	A
Output clamp (inductive load switch off) at $V_{OUT} = V_{bb} - V_{ON(CL)}$; $I_L = 40\text{ mA}$, $T_i = -40\text{ °C}$: $T_j = +25\text{ °C}..+150\text{ °C}$:	$V_{ON(CL)}$	41 43	-- 47	-- 52	V
Thermal overload trip temperature	T_{jt}	150	--	--	°C
Thermal hysteresis	ΔT_{jt}	--	10	--	K
Reverse battery (pin 4 to 2) ⁸⁾	$-V_{bb}$	--	--	32	V
Reverse battery voltage drop ($V_{out} > V_{bb}$) $I_L = -5\text{ A}$ $T_j = 150\text{ °C}$:	$-V_{ON(rev)}$	--	600	--	mV

Diagnostic Characteristics

Current sense ratio ⁹⁾ , static on-condition, $V_{IS} = 0..5\text{ V}$, $V_{bb(on)} = 6.5^{10)}..27\text{ V}$, $k_{ILIS} = I_L / I_{IS}$ $T_j = -40\text{ °C}$, $I_L = 5\text{ A}$: $T_j = -40\text{ °C}$, $I_L = 0.5\text{ A}$: $T_j = 25..+150\text{ °C}$, $I_L = 5\text{ A}$: $T_j = 25..+150\text{ °C}$, $I_L = 0.5\text{ A}$:	k_{ILIS}	4550 3300 4550 4000	5000 5000 5000 5000	6000 8000 5550 6500	
Current sense output voltage limitation $T_j = -40\text{ °C}..+150\text{ °C}$ $I_{IS} = 0$, $I_L = 5\text{ A}$:	$V_{IS(lim)}$	5.4	6.1	6.9	V
Current sense leakage/offset current $T_j = -40\text{ °C}..+150\text{ °C}$ $V_{IN} = 0$, $V_{IS} = 0$, $I_L = 0$:	$I_{IS(LL)}$	0	--	1	μA



⁸⁾ Requires 150 Ω resistor in GND connection. The reverse load current through the intrinsic drain-source diode has to be limited by the connected load. Note that the power dissipation is higher compared to normal operating conditions due to the voltage drop across the intrinsic drain-source diode. The temperature protection is not active during reverse current operation! Input and Status currents have to be limited (see max. ratings page 2 and circuit page 10).

⁹⁾ This range for the current sense ratio refers to all devices. The accuracy of the k_{ILIS} can be raised at least by a factor of two by matching the value of k_{ILIS} for every single device.
In the case of current limitation the sense current I_{IS} is zero and the diagnostic feedback potential V_{ST} is High. See figure 2b, page 12.

¹⁰⁾ Valid if $V_{bb(u\text{ rst})}$ was exceeded before.

Parameter and Conditions at $T_j = 25\text{ °C}$, $V_{bb} = 12\text{ V}$ unless otherwise specified	Symbol	Values			Unit
		min	typ	max	
$V_{IN}=5\text{ V}$, $V_{IS} = 0$, $I_L = 0$:	$I_{IS(LH)}$	0	--	15	
$V_{IN}=5\text{ V}$, $V_{IS} = 0$, $V_{OUT} = 0$ (short circuit)	$I_{IS(SH)}$	0	--	10	
: $I_{IS(SH)}$ not tested, specified by design)					
Current sense settling time to $I_{IS\text{ static}}\pm 10\%$ after positive input slope, $I_L = 0 \rightarrow 5\text{ A}$, $T_j = -40\dots+150\text{ °C}$ (not tested, specified by design)	$t_{\text{son}(IS)}$	--	--	300	μs
Current sense settling time to 10% of $I_{IS\text{ static}}$ after negative input slope, $I_L = 5 \rightarrow 0\text{ A}$, $T_j = -40\dots+150\text{ °C}$ (not tested, specified by design)	$t_{\text{soff}(IS)}$	--	30	100	μs
Current sense rise time (60% to 90%) after change of load current $I_L = 2.5 \rightarrow 5\text{ A}$ (not tested, specified by design)	$t_{\text{slc}(IS)}$	--	10	--	μs
Open load detection voltage ¹¹⁾ (off-condition) $T_j = -40\dots+150\text{ °C}$:	$V_{\text{OUT}(OL)}$	2	3	4	V
Internal output pull down (pin 6 to 2), $V_{\text{OUT}}=5\text{ V}$, $T_j=-40\dots+150\text{ °C}$	R_O	5	15	40	$\text{k}\Omega$

Input and Status Feedback¹²⁾

Input resistance see circuit page 9	R_I	3,0	4,5	7,0	$\text{k}\Omega$
Input turn-on threshold voltage  $T_j = -40\dots+150\text{ °C}$:	$V_{\text{IN}(T+)}$	--	--	3.5	V
Input turn-off threshold voltage  $T_j = -40\dots+150\text{ °C}$:	$V_{\text{IN}(T-)}$	1.5	--	--	V
Input threshold hysteresis	$\Delta V_{\text{IN}(T)}$	--	0.5	--	V
Off state input current (pin 3), $V_{\text{IN}} = 0.4\text{ V}$ $T_j = -40\dots+150\text{ °C}$	$I_{\text{IN}(off)}$	1	--	50	μA
On state input current (pin 3), $V_{\text{IN}} = 5\text{ V}$ $T_j = -40\dots+150\text{ °C}$	$I_{\text{IN}(on)}$	20	50	90	μA
Delay time for status with open load after Input neg. slope (see diagram page 14)	$t_{\text{d}(ST\text{ OL}3)}$	--	400	--	μs
Status delay after positive input slope (not tested, specified by design) $T_j = -40\dots+150\text{ °C}$:	$t_{\text{don}(ST)}$	--	13	--	μs
Status delay after negative input slope (not tested, specified by design) $T_j = -40\dots+150\text{ °C}$:	$t_{\text{doff}(ST)}$	--	1	--	μs

11) External pull up resistor required for open load detection in off state.

12) If a ground resistor R_{GND} is used, add the voltage drop across this resistor.

Parameter and Conditions at $T_j = 25\text{ }^\circ\text{C}$, $V_{bb} = 12\text{ V}$ unless otherwise specified	Symbol	Values			Unit
		min	typ	max	
Status output (open drain)					
Zener limit voltage $T_j = -40\dots+150\text{ }^\circ\text{C}$, $I_{ST} = +1.6\text{ mA}$:	$V_{ST(\text{high})}$	5.4	6.1	6.9	V
ST low voltage $T_j = -40\dots+25\text{ }^\circ\text{C}$, $I_{ST} = +1.6\text{ mA}$:	$V_{ST(\text{low})}$	--	--	0.4	
$T_j = +150\text{ }^\circ\text{C}$, $I_{ST} = +1.6\text{ mA}$:		--	--	0.7	
Status leakage current, $V_{ST} = 5\text{ V}$, $T_j = 25 \dots +150\text{ }^\circ\text{C}$:	$I_{ST(\text{high})}$	--	--	2	μA

Truth Table

	Input level	Output level	Status level	Current Sense I_{IS}
Normal operation	L	L	H	0
	H	H	L	nominal
Current-limitation	L	L	H	0
	H	H	H	0
Short circuit to GND	L	L	H	0
	H	L ¹³⁾	H	0
Over-temperature	L	L	H	0
	H	L	H	0
Short circuit to V_{bb}	L	H	L ¹⁴⁾	0
	H	H	L	<nominal ¹⁵⁾
Open load	L	L ¹⁶⁾	H (L ¹⁷⁾)	0
	H	H	L	0
Undervoltage	L	L	H	0
	H	L	L	0
Overvoltage	L	L	H	0
	H	L	L	0
Negative output voltage clamp	L	L	H	0

L = "Low" Level
H = "High" Level

X = don't care

Z = high impedance, potential depends on external circuit

Status signal after the time delay shown in the diagrams (see fig 5. page 13...14)

-
- 13) The voltage drop over the power transistor is $V_{bb} - V_{OUT} > \text{typ.} 3V$. Under this condition the sense current I_{IS} is zero
- 14) An external short of output to V_{bb} , in the off state, causes an internal current from output to ground. If R_{GND} is used, an offset voltage at the GND and ST pins will occur and the $V_{ST\ low}$ signal may be errorious.
- 15) Low ohmic short to V_{bb} may reduce the output current I_L and therefore also the sense current I_{IS} .
- 16) Power Transistor off, high impedance
- 17) with external resistor between pin 4 and pin 6&7

Terms

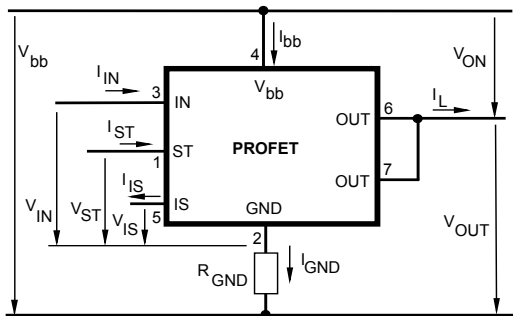

Input circuit (ESD protection)

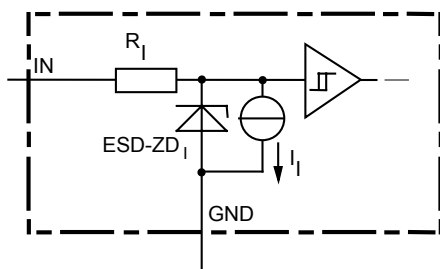

The use of ESD zener diodes as voltage clamp at DC conditions is not recommended.

Status output

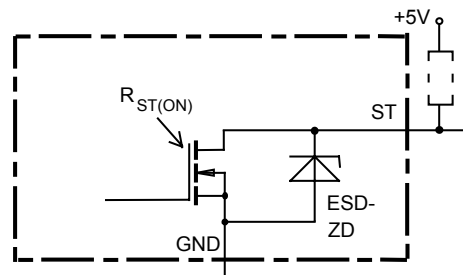

ESD-Zener diode: 6.1 V typ., max 5 mA;
R_{ST(ON)} < 440 Ω at 1.6 mA, The use of ESD zener diodes as voltage clamp at DC conditions is not recommended.

Current sense output

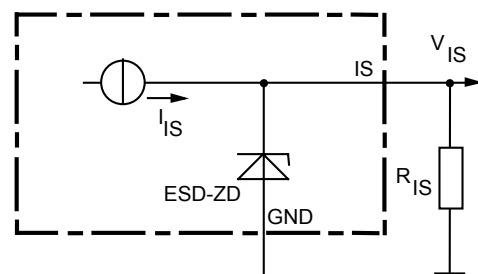

ESD-Zener diode: 6.1 V typ., max 14 mA;
R_{IS} = 1 kΩ nominal

Inductive and overvoltage output clamp

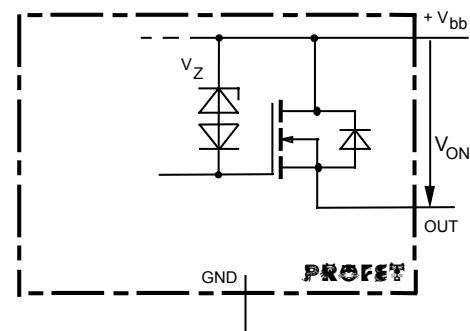

V_{ON} clamped to 47 V typ.

Overvoltage protection of logic part

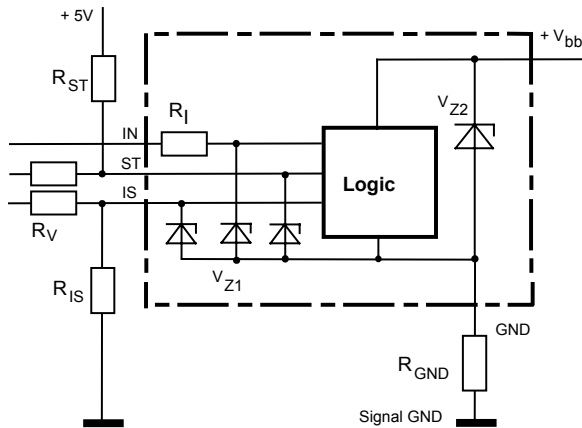

$V_{Z1} = 6.1 \text{ V typ.}$, $V_{Z2} = 47 \text{ V typ.}$, $R_I = 4 \text{ k}\Omega \text{ typ.}$, $R_{GND} = 150 \Omega$, $R_{ST} = 15 \text{ k}\Omega$, $R_{IS} = 1 \text{ k}\Omega$, $R_V = 15 \text{ k}\Omega$,

Reverse battery protection

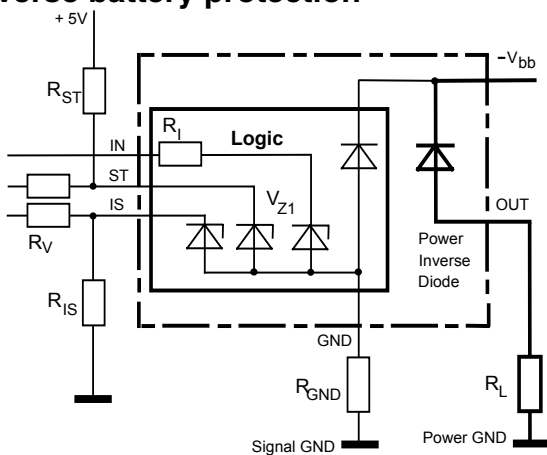

The load R_L is inverse on, temperature protection is not active

$R_{GND} = 150 \Omega$, $R_I = 4 \text{ k}\Omega \text{ typ.}$, $R_{ST} \geq 500 \Omega$, $R_{IS} \geq 200 \Omega$, $R_V \geq 500 \Omega$,

Open-load detection

OFF-state diagnostic condition: $V_{OUT} > 3 \text{ V typ.}$; IN low

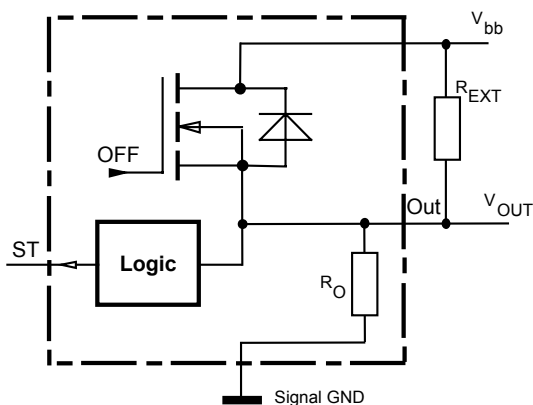

GND disconnect

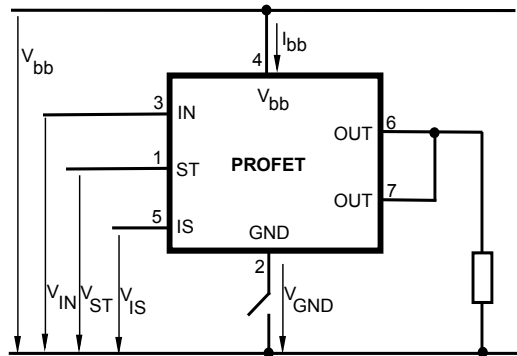

Any kind of load. In case of Input=high is $V_{OUT} \approx V_{IN} - V_{IN(T+)}$.
Due to $V_{GND} > 0$, no $V_{ST} = \text{low signal}$ available.

GND disconnect with GND pull up

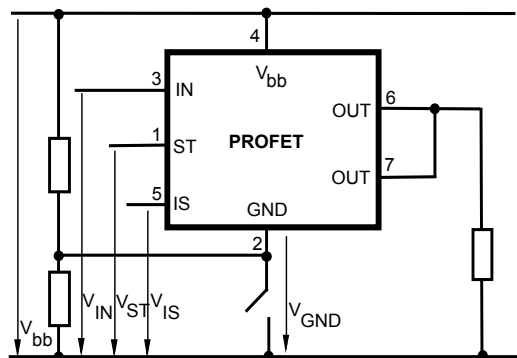

Any kind of load. If $V_{GND} > V_{IN} - V_{IN(T+)}$ device stays off
Due to $V_{GND} > 0$, no $V_{ST} = \text{low signal}$ available.

V_{bb} disconnect with energized inductive load

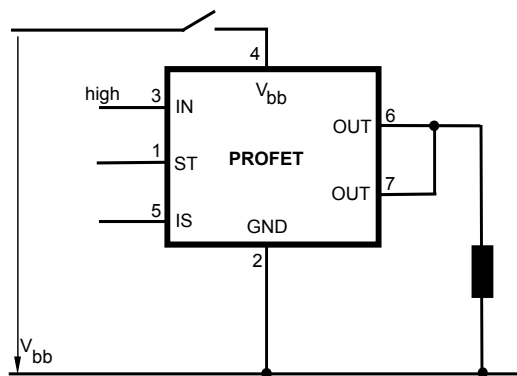

Normal load current can be handled by the PROFET itself.

V_{bb} disconnect with charged external inductive load

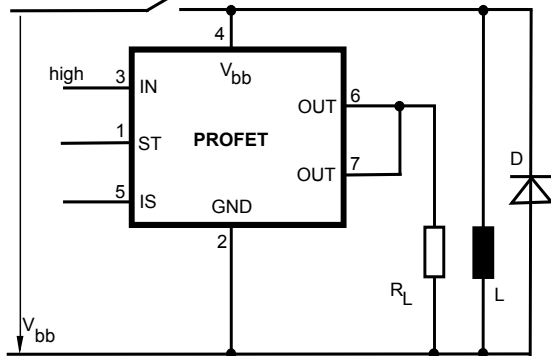

If other external inductive loads L are connected to the PROFET, additional elements like D are necessary.

Inductive Load switch-off energy dissipation

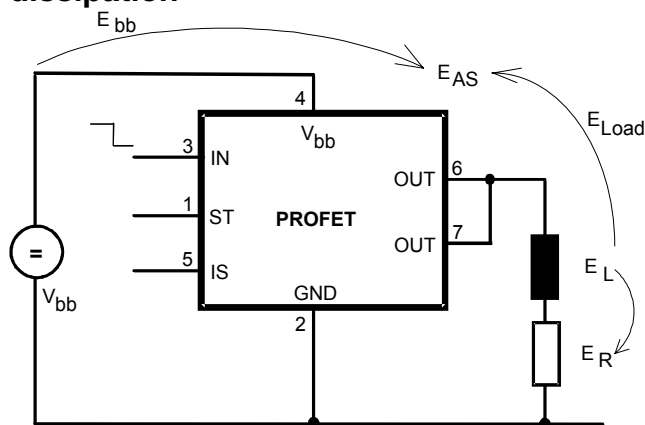

Energy stored in load inductance:

$$E_L = \frac{1}{2} \cdot L \cdot I_L^2$$

While demagnetizing load inductance, the energy dissipated in PROFET is

$$E_{AS} = E_{bb} + E_L - E_R = \int V_{ON(CL)} \cdot i_L(t) dt,$$

with an approximate solution for $R_L > 0 \Omega$:

$$E_{AS} = \frac{I_L \cdot L}{2 \cdot R_L} \cdot (V_{bb} + |V_{OUT(CL)}|) \cdot \ln \left(1 + \frac{I_L \cdot R_L}{|V_{OUT(CL)}|} \right)$$

Timing diagrams

Figure 1a: Switching a resistive load, change of load current in on-condition:

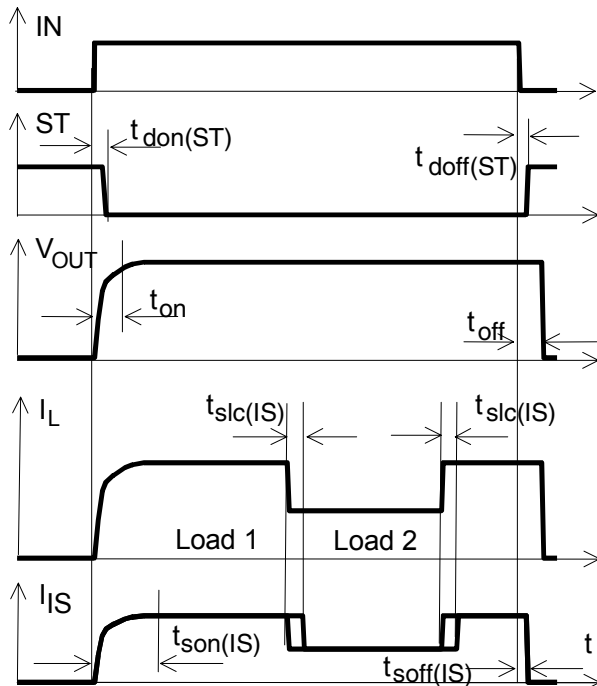

The sense signal is not valid during settling time after turn or change of load current.

Figure 1b: V_{bb} turn on:

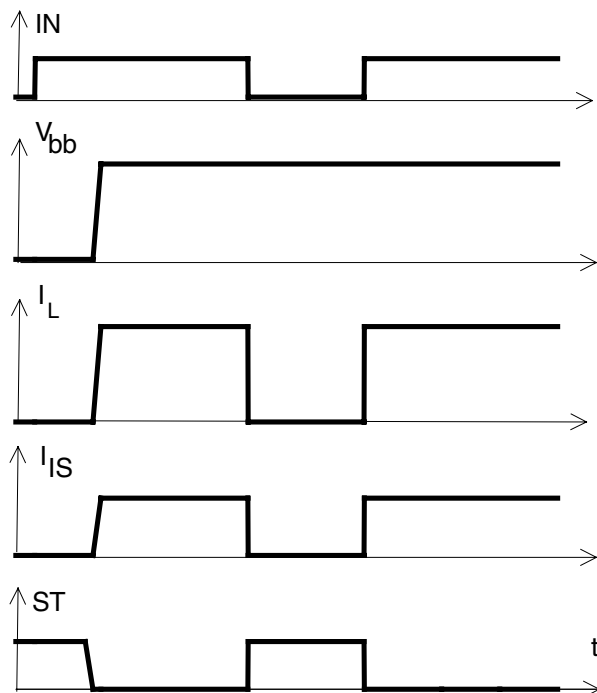

proper turn on under all conditions

Figure 2a: Switching a lamp

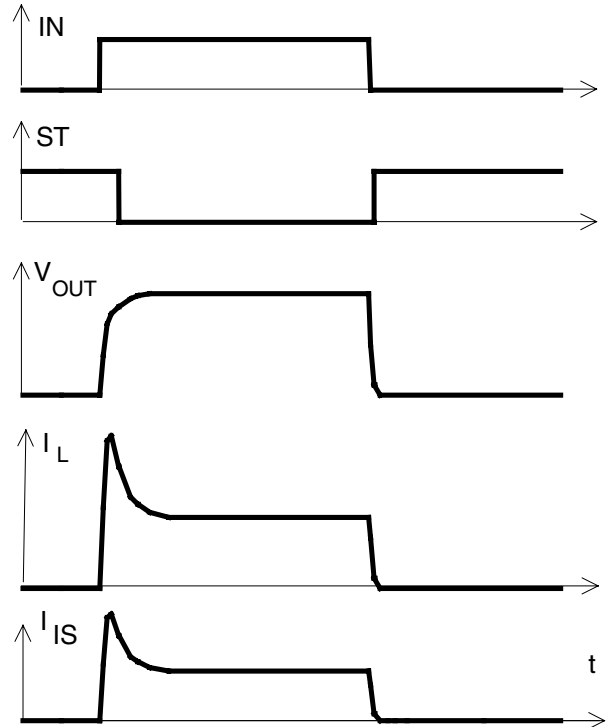

Figure 2b: Switching a lamp with current limit:

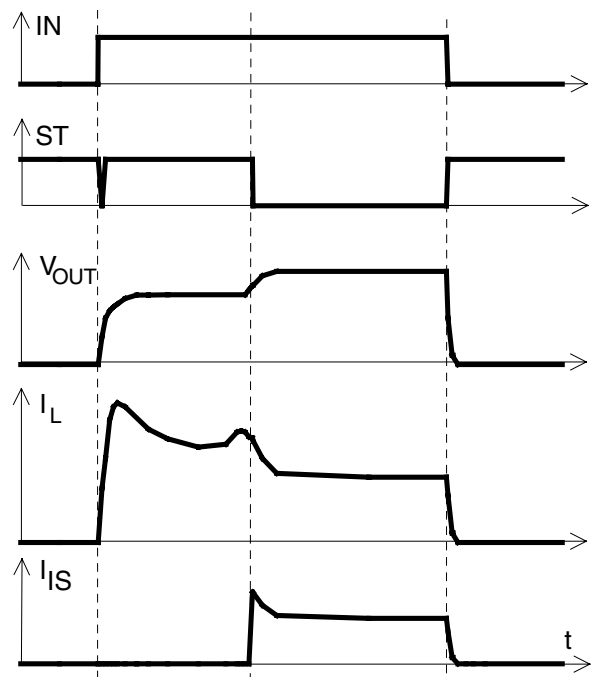

Figure 2c: Switching an inductive load:

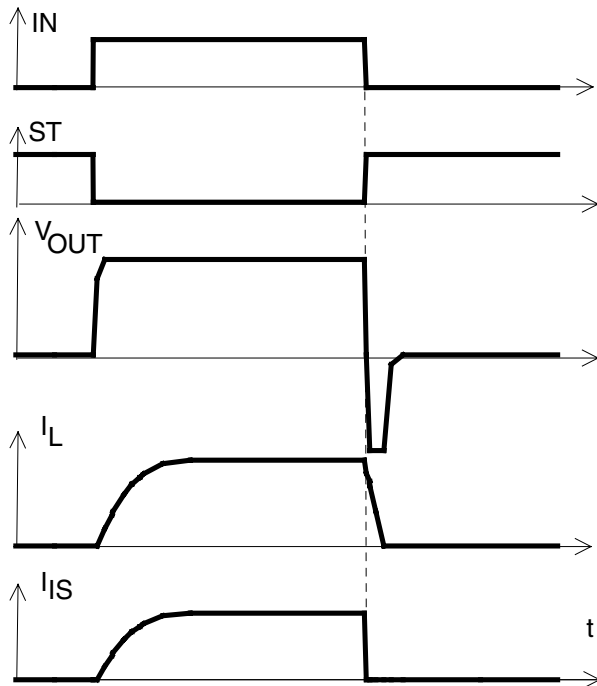
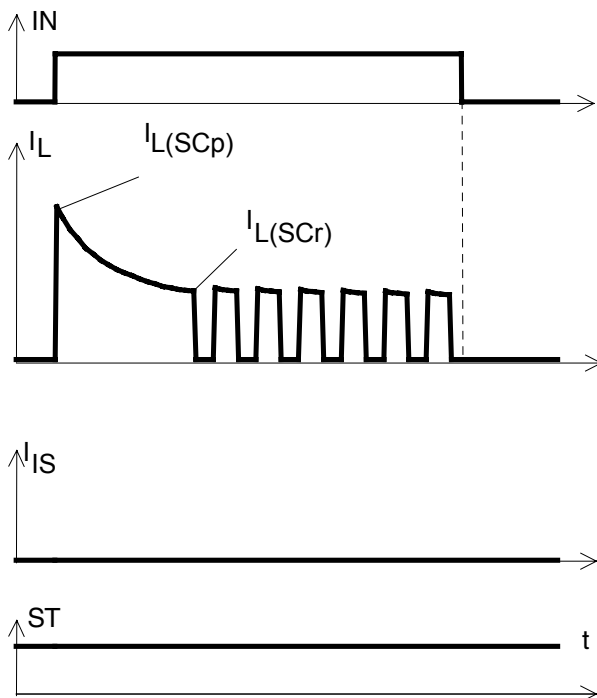

Figure 3a: Short circuit: shut down by overtemperature, reset by cooling



Heating up may require several milliseconds, depending on external conditions
 $I_{L(SCp)} = 50 \text{ A typ.}$ increases with decreasing temperature.

Figure 4a: Overtemperature: Reset if $T_j < T_{jt}$

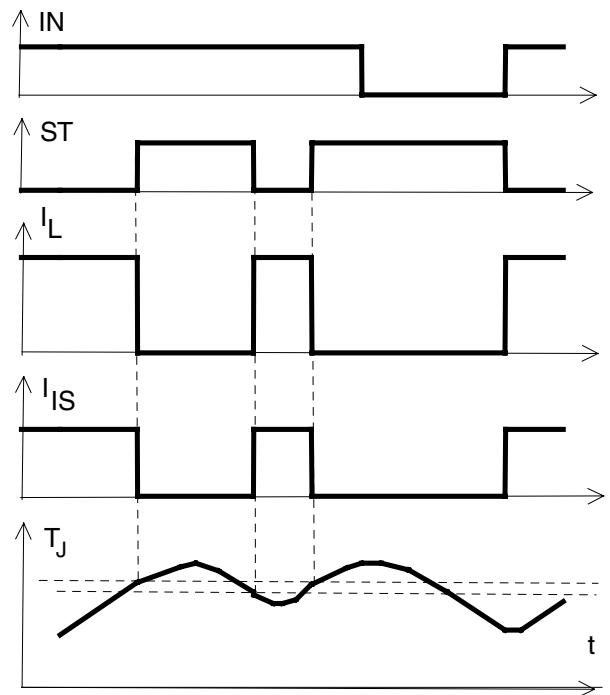

Figure 5a: Open load: detection in ON-state, open load occurs in on-state

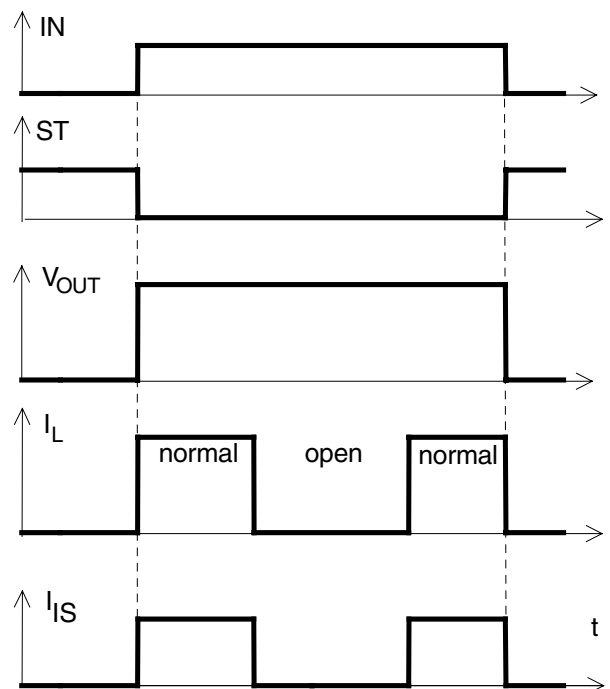

Figure 5b: Open load: detection in ON- and OFF-state (with R_{EXT}), turn on/off to open load

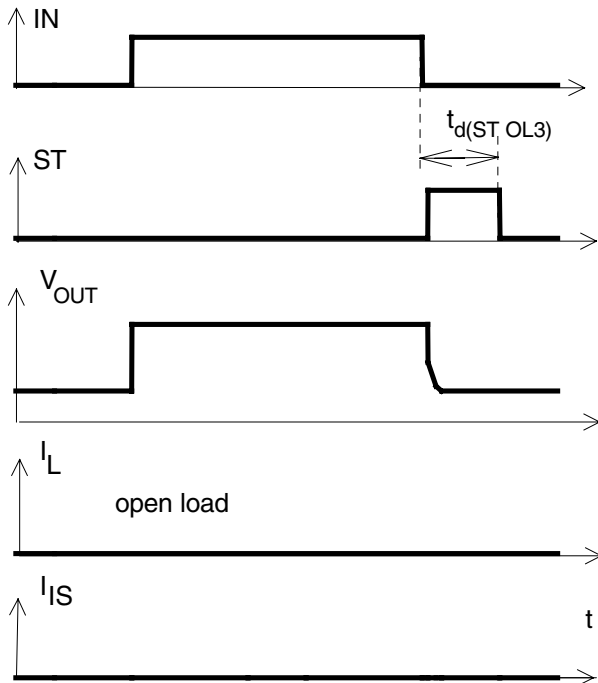

Figure 6a: Undervoltage:

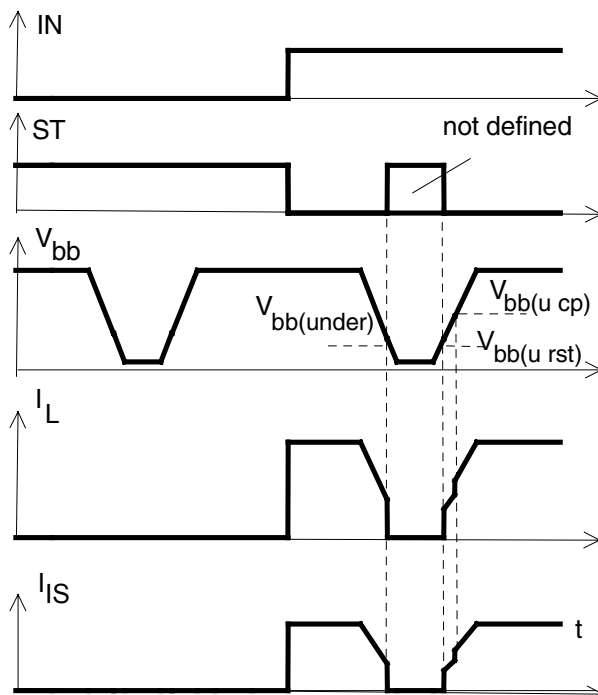

Figure 6b: Undervoltage restart of charge pump

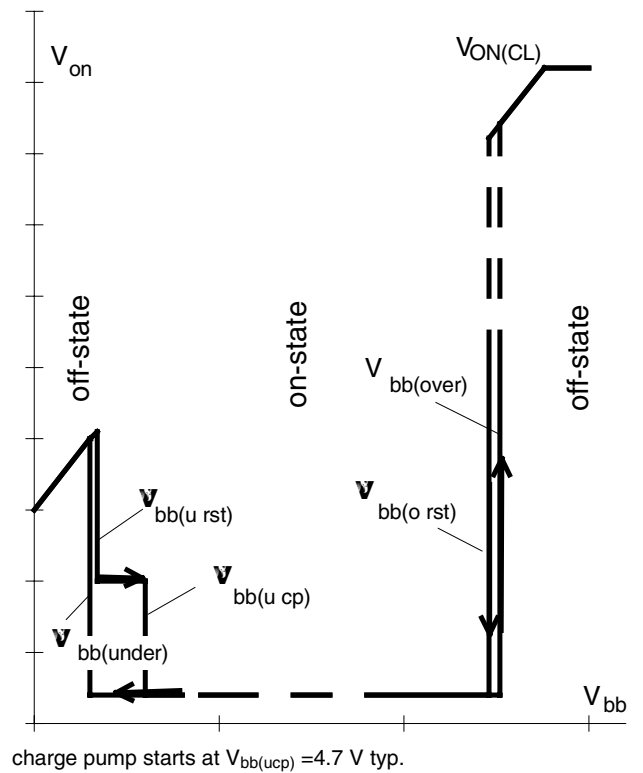

Figure 7a: Overvoltage:

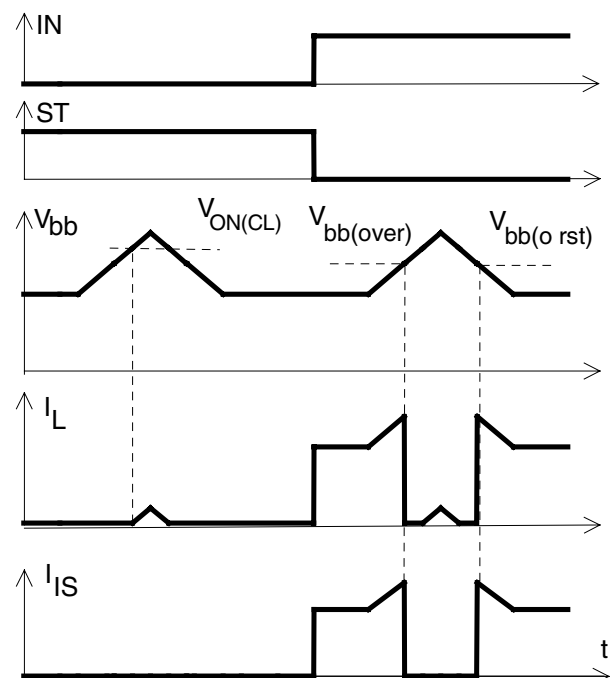

Figure 8a: Current sense versus load current:

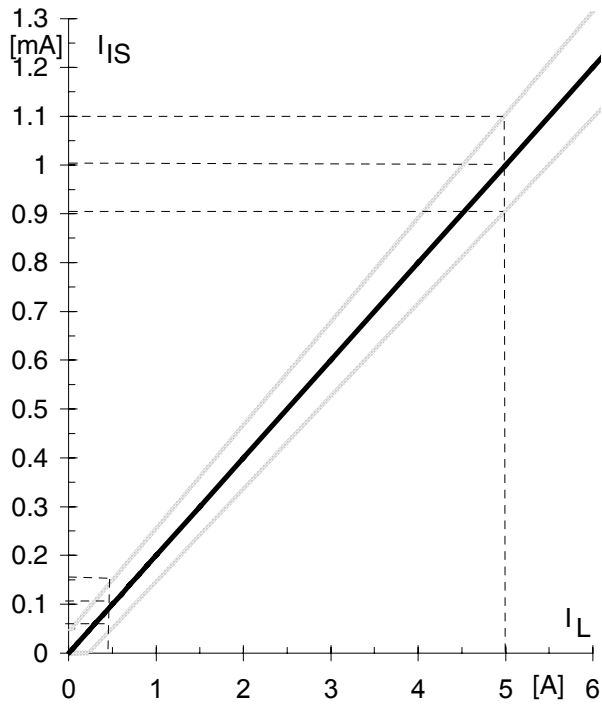

Figure 8b: Current sense ratio¹⁸:

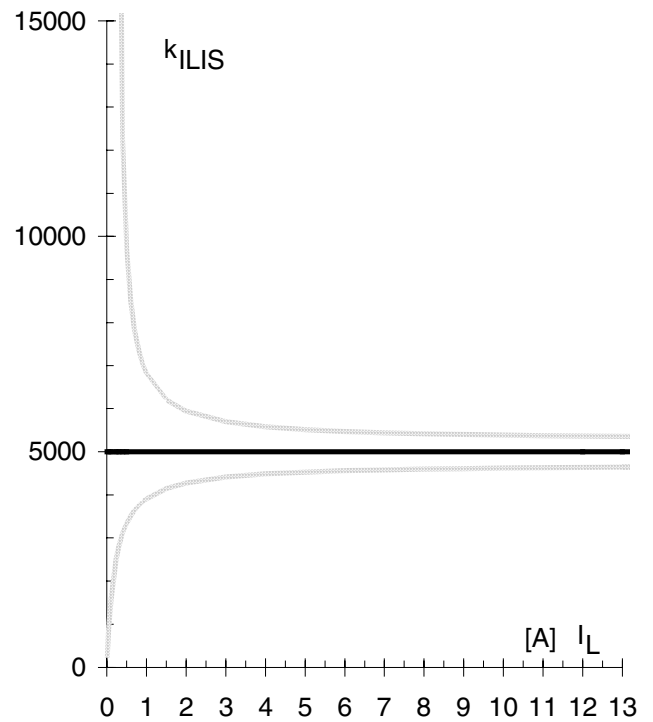
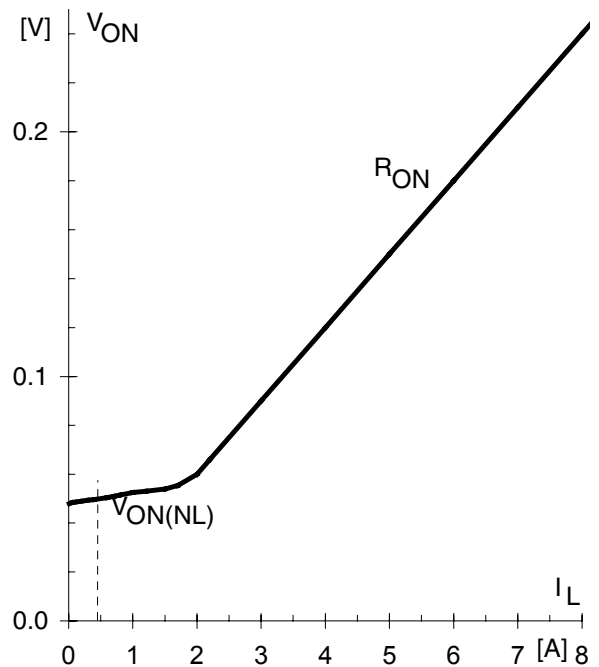

Figure 9a: Output voltage drop versus load current:



¹⁸ This range for the current sense ratio refers to all devices. The accuracy of the k_{ILIS} can be raised at least by a factor of two by matching the value of k_{ILIS} for every single device.

Package and Ordering Code

All dimensions in mm

Standard (=staggered): P-TO220-7-11

Sales code	BTS640S2
Ordering code	Q67060-S6307-A5

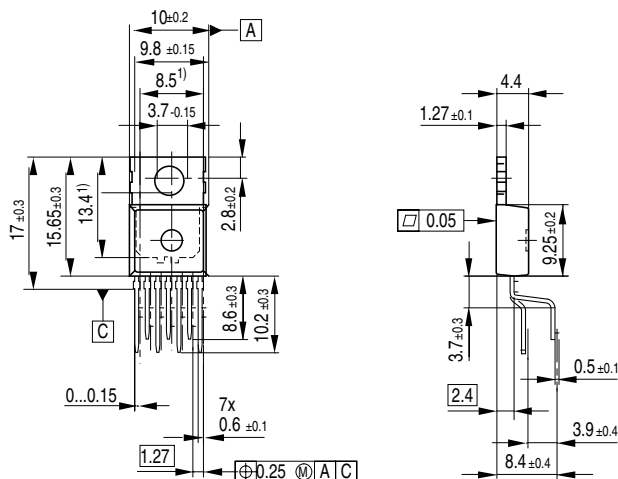

¹⁾ Typical
All metal surfaces tin plated, except area of cut.

Straight: P-TO220-7-12

Sales Code	BTS640S2 S
Ordering code	Q67060-S6307-A7

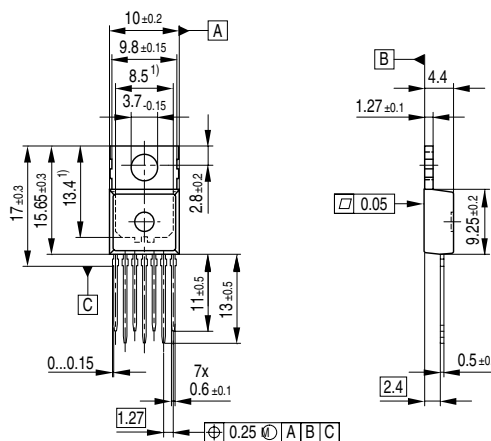

¹⁾ Typical
All metal surfaces tin plated, except area of cut.

Published by Siemens AG, Bereich Bauelemente, Vertrieb, Produkt-Information, Balanstraße 73, D-81541 München Siemens AG 2002. All Rights Reserved

As far as patents or other rights of third parties are concerned, liability is only assumed for components per se, not for applications, processes and circuits implemented within components or assemblies. The information describes a type of component and shall not be considered as warranted characteristics. The characteristics for which SIEMENS grants a warranty will only be specified in the purchase contract. Terms of delivery and rights to change design reserved. For questions on technology, delivery and prices please contact the Offices of Semiconductor Group in Germany or the Siemens Companies and Representatives worldwide (see address list). Due to technical requirements components may contain dangerous substances. For information on the type in question please contact your nearest Siemens Office, Semiconductor Group. Siemens AG is an approved CECC manufacturer.

Packing: Please use the recycling operators known to you. We can also help you - get in touch with your nearest sales office. By agreement we will take packing material back, if it is sorted. You must bear the costs of transport. For packing material that is returned to us unsorted or which we are not obliged to accept we shall have to invoice you for any costs incurred.

Components used in life-support devices or systems must be expressly authorised for such purpose! Critical components¹⁹⁾ of the Semiconductor Group of Siemens AG, may only be used in life supporting devices or systems²⁰⁾ with the express written approval of the Semiconductor Group of Siemens AG.

SMD: P-TO263-7-2

(tape&reel)

Sales code	BTS640S2 G
------------	------------

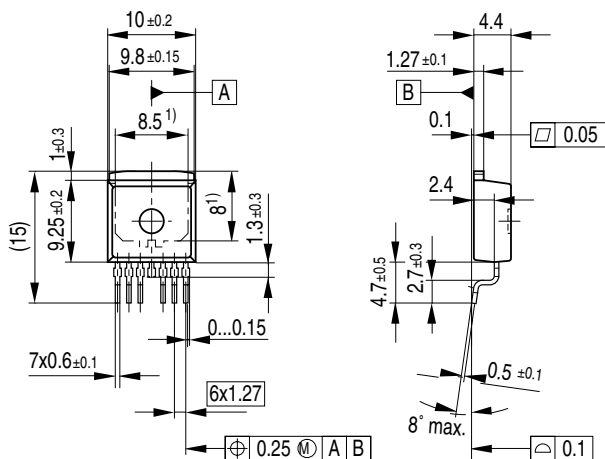

¹⁾ Typical
All metal surfaces tin plated, except area of cut.

Ordering code	Q67060-S6307-A6
---------------	-----------------

¹⁹⁾ A critical component is a component used in a life-support device or system whose failure can reasonably be expected to cause the failure of that life-support device or system, or to affect its safety or effectiveness of that device or system.

²⁰⁾ Life support devices or systems are intended (a) to be implanted in the human body or (b) support and/or maintain and sustain and/or protect human life. If they fail, it is reasonably to assume that the health of the user or other persons may be endangered.