

Temperature Compensated Crystal Oscillator CSX-532T Series (2000pcs/reel)

CITIZEN

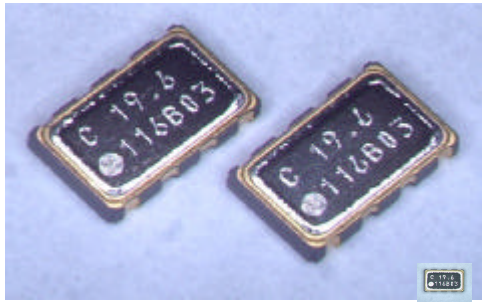

Life Size

[Features]

- Surface Mount Type.
- Tape & Reel
- Ultra Small Size and Light Weight.
- Low Power Consumption.
- Low Harmonics

[Applications]

Cellular phones

[Recommended Pad Layout (mm)]

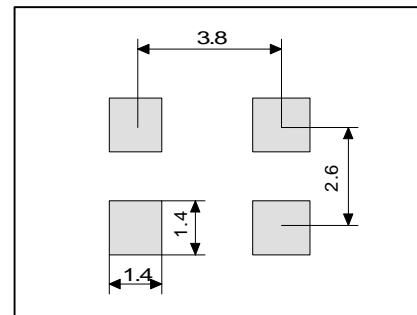

[Dimensions (mm)]

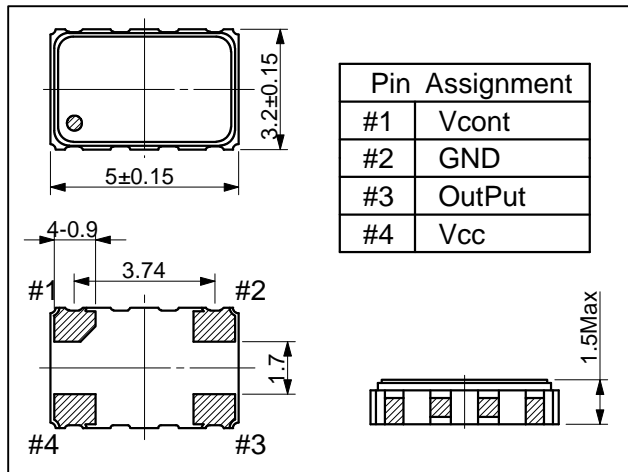

[Test Circuit]

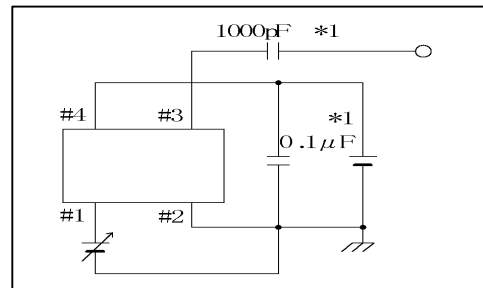

[Standard Specifications]

	CSX-532T
Standard Frequencies	13.0, 14.4, 16.8, 19.2, 19.68, 19.8, 26.0MHz
Supply Voltage	2.8V±5% , 3.0V±5%
Frequency Toleran	±1.5ppm / 25±2°C
Frequency/Temperature	±2.5ppm / -30 to +75°C
Frequency/Voltage Coefficient	±0.3ppm / Vdd±5%
Frequency/Load Coefficient	±0.2ppm / (10kohm//10pF)±10%
Aging	±1.0ppm / Year
Power Consumption	1.0mA MAX. / 13MHz
Output Level	0.8Vp-p MIN. / (10kohm//10pF)
Startup Time	3.5msec MAX.
Frequency Adjustment	±8ppm Min. / Vdd/2±1.0V

* Please consult us for non-standard specifications.

*1 Capacitors should be connected to Vcc and to Fout.