

Scale 4:1

Features

- ▶ Ultra-miniature for maximum space saving
- ▶ Ideal for Bluetooth / Wireless applications
- ▶ Metal lid can be grounded to minimise EMI
- ▶ Seam sealed for excellent long-term stability

Bluetooth Applications

Frequency	Specification	IC	Part No
16.0MHz	9pF, 9ppm/pF typ pullability	CSR	MA07246*
26.0MHz	9pF, 14ppm/pF typ pullability	CSR	MA07232*

* Designed for use with CSR chipset solutions. Golledge is a global supply partner for CSR

Specifications

Parameters	Product	Option Codes
	GSX-323	
Frequency range: 16.0 ~ 48.0MHz	■	
Calibration tolerance: ±10ppm ±15ppm ±20ppm Other values (±7.5 ~ ±100ppm)	■ □ □ □	1 P 2 specify
Temperature stability: ±10ppm ±15ppm ±20ppm ±30ppm Other values (±7.5 ~ ±100ppm)	■ □ □ □ □	1 P 2 3 specify
Operating temperature range: -10 to +60°C -20 to +70°C -30 to +80°C Other values	■ □ □ □	1 2 3 specify
Storage temperature range: -40 to +85°C	■	
Circuit condition: 8pF 9pF 12pF 16pF Series resonant Other values	□ □ □ ■ □ □	M N B D S specify
Oscillation mode: Fundamental	■	F
Equivalent series resistance: 100Ω max	■	
Ageing: ±1ppm max first year	■	
Test drive level: 10μW	■	
Soldering condition: 260°C, 10 sec x2 max	■	

■ Standard. □ Optional - Please specify required code(s) when ordering

Ordering Information

Part No, or product name + option codes + frequency

eg: **GSX-323/111NF 16.0MHz** 10/10/10/9-F

GSX-323/1P3AF 26.0MHz 10/15/30/10-F

Option code X (eg GSX-323/X) denotes a custom specification.

♦ ±10ppm temperature stability may not be available over -30+80°C. Check with our sales office before ordering.

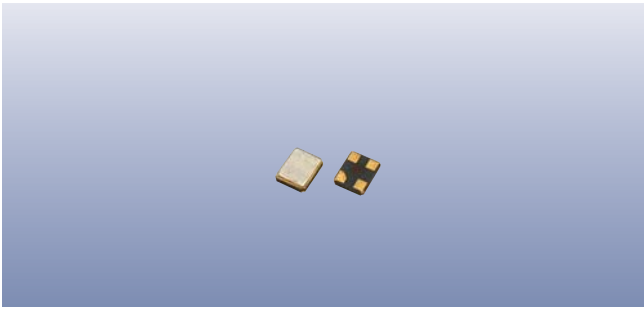

Construction

- ▮▮▮▮ **Ceramic body with gold-plated pads**
- ▮▮▮▮ **Metal lid, seam sealed**

Composition



This product is lead-free, and is fully compliant with the RoHS directive 2002/95/EC



Packaging & Handling

Production quantities supplied on T & R, 1k or 2k pcs per reel.
Small quantities may be supplied on tape (no reel), or in bulk.

Marking

FREQUENCY
T DC

Marking type: Laser
DC = Date code in YW, as shown below
Example: "xd" = 2006 week 30

Year	2001	2002	2003	2004
	2005	2006	2007	2008
Code	X	x	<u>X</u>	<u>x</u>

Week codes:
A ~ Z: weeks 1 to 26
a ~ z: weeks 27 to 52

Tape & Reel Specification

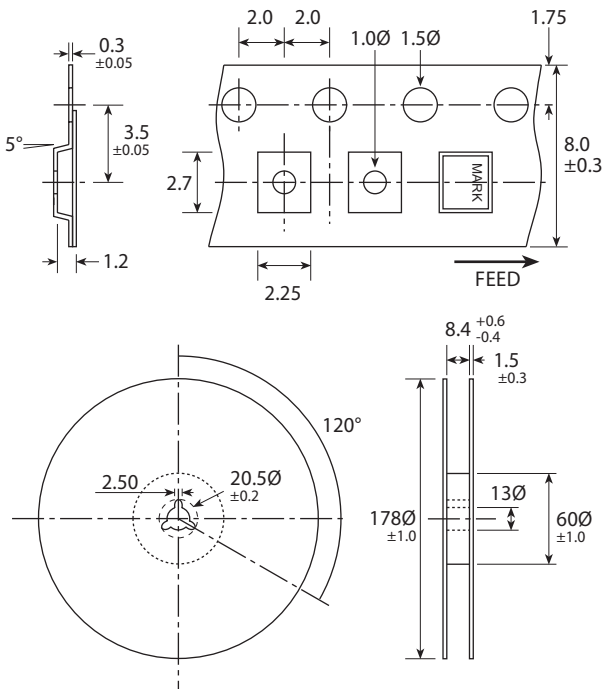

Not to scale. Dimensional tolerances ±0.1mm unless otherwise stated

Soldering Profile

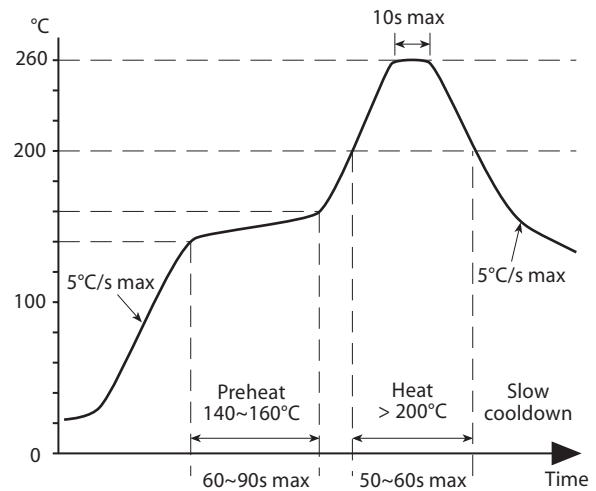

Maximum solder resistance: 260°C x 10 secs x 2.