

## MECHANICAL DATA

Dimensions in mm (inches)

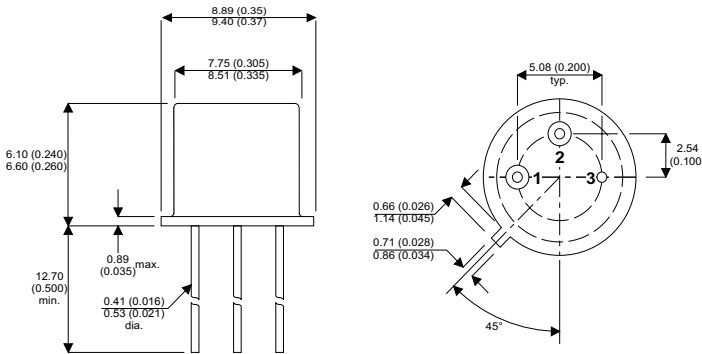

### H Package TO39

Pin 1 =  $V_{in}$     Pin 2 = ADJ.    Pin 3 =  $V_{out}$

## 0.5 AMP POSITIVE ADJUSTABLE VOLTAGE REGULATOR

### FEATURES

- Output Voltage Range Adjustable:  
1.25 to 40V For Standard Version  
1.25 to 60V For –HV Version
- 1% Output Voltage Tolerance  
(–A Versions)
- 0.3% Load Regulation
- 0.01%/V Line Regulation
- Complete Series Of Protections:
  - Current Limiting
  - Thermal Shutdown
  - SOA Control
- Also Available In Ceramic SMD1 and LCC4 Hermetic Ceramic Surface Mount Packages.

## DESCRIPTION

The IP117M Series are three terminal positive adjustable voltage regulators capable of supplying in excess of 0.5A over a 1.25V to 60V output range. These regulators are exceptionally easy to use and require only two external resistors to set the output voltage. In addition to improved line and load regulation, a major feature of the “A” series is the initial output voltage tolerance, which is guaranteed to be less than 1%.

Over full operating conditions, including load, line, and power dissipation, the reference voltage is guaranteed not to vary more than 2%. These devices exhibit current limit, thermal overload protection, and improved power device safe operating area protection, making them essentially indestructible.

## ABSOLUTE MAXIMUM RATINGS ( $T_{case} = 25^{\circ}C$ unless otherwise stated)

$V_{I-O}$	Input - Output Differential Voltage	– Standard	40V
		– HV Series	60V
$P_D$	Power Dissipation		Internally limited
$T_J$	Operating Junction Temperature Range		–55 to 150°C
$T_{STG}$	Storage Temperature		–65 to 150°C

Parameter	Test Conditions	IP117MAHV IP117MA			IP117MHV , IP117M			Units	
		Min.	Typ.	Max.	Min.	Typ.	Max.		
$V_{REF}$ Reference Voltage	$I_{OUT} = 10mA$	1.238	1.25	1.262				V	
	$I_{OUT} = 10mA$ to $I_{MAX}$ $V_{IN} - V_{OUT} = 3V$ to $V_{MAX}$ $P \leq P_{MAX}$ $T_J = -55$ to $+150^\circ C$	1.220	1.250	1.270	1.200	1.250	1.300	V	
$\frac{\Delta V_{OUT}}{\Delta V_{IN}}$ Line Regulation 1	$V_{IN} - V_{OUT} = 3V$ to $V_{MAX}$ $T_J = -55$ to $+150^\circ C$		0.005	0.010		0.010	0.020	% / V	
			0.010	0.020		0.020	0.050		
$\frac{\Delta V_{OUT}}{\Delta I_{OUT}}$ Load Regulation 1	$I_{OUT} = 10mA$ to $I_{MAX}$	$V_{OUT} \leq 5V$		5	15		5	15	mV
		$V_{OUT} \geq 5V$		0.1	0.3		0.1	0.3	%
	$I_{OUT} = 10mA$ to $I_{MAX}$ $T_J = -55$ to $+150^\circ C$	$V_{OUT} \leq 5V$		15	50		20	50	mV
		$V_{OUT} \geq 5V$		0.3	1		0.3	1	%
Thermal Regulation	$t_p = 20ms$		0.002	0.020		0.030	0.070	%/W	
Ripple Rejection	$V_{OUT} = 10V$ $f = 120Hz$ $T_J = -55$ to $+150^\circ C$	$C_{ADJ} = 0$		65			65	dB	
		$C_{ADJ} = 10\mu F$	66	80		66	80	dB	
$I_{ADJ}$ Adjust Pin Current	$T_J = -55$ to $+150^\circ C$		50	100		50	100	$\mu A$	
$\Delta I_{ADJ}$ Adjust Pin Current Change	$I_{OUT} = 10mA$ to $I_{MAX}$ $T_J = -55$ to $+150^\circ C$ $V_{IN} - V_{OUT} = 2.5V$ to $V_{MAX}$		0.2	5		0.2	5	$\mu A$	
$I_{MIN}$ Minimum Load Current	$V_{IN} - V_{OUT} = 40V$ $T_J = -55$ to $+150^\circ C$		3.5	5		3.5	5	mA	
	$V_{IN} - V_{OUT} = 60V$ (HV SERIES) $T_J = -55$ to $+150^\circ C$		3.5	7		3.5	7		
$I_{CL}$ Current Limit	$V_{IN} - V_{OUT} \leq 15V$ $T_J = -55$ to $+150^\circ C$		0.50	0.80		0.50	0.80	A	
	$V_{IN} - V_{OUT} = 40V$		0.15	0.20		0.15	0.20	A	
	$V_{IN} - V_{OUT} = 60V$ (HV SERIES)			0.30			0.30		
$\frac{\Delta V_{OUT}}{\Delta TEMP}$ Temperature Stability	$T_J = -55$ to $+150^\circ C$		1	2		1		%	
$\frac{\Delta V_{OUT}}{\Delta TIME}$ Long Term Stability	$T_A = +125^\circ C$ $t = 1000$ Hrs		0.3	1		0.3	1	%	
$e_n$ RMS Output Noise (% of $V_{OUT}$ )	$f = 10$ Hz to $10$ kHz		0.001			0.001		%	
$R_{\theta JC}$ Thermal Resistance Junction to Case	LCC4 Package		TBA			TBA		$^\circ C/W$	

1) Regulation is measured at constant junction temperature, using pulse testing at a low duty cycle. Changes in output voltage due to heating effects are covered under thermal regulation specifications. Load regulation is measured  $1/8''$  below the base of the package on the output pin.

2) Test Conditions unless otherwise stated:  $V_{IN} - V_{OUT} = 5V$ ,  $T_J = 25^\circ C$ ,  $I_{OUT} = 0.1A$ ,  $P_{MAX} = TBA$ ,  $I_{MAX} = 0.5A$   
 $V_{MAX} = 40V$  for standard series,  $60V$  for HV series.