FEATURES

- Ø 500 µm active area
- High gain at low bias voltage
- Fast rise time
- Low capacitance

DESCRIPTION

0.196 mm² High Speed, High Gain Avalanche Photodiode with N on P construction. Hermetically packaged in a TO-52-S1 with a clear borosilicate glass window cap.

APPLICATIONS

- High speed optical communications
- Laser range finder
- Medical equipment
- High speed photometry

ABSOLUTE MAXIMUM RATING

SYMBOL	PARAMETER	MIN	MAX	UNITS
T _{STG}	Storage Temp	-55	+125	°C
T _{OP}	Operating Temp	-40	+100	°C
T _{SOLDERING}	Soldering Temp 10 seconds		+260	°C
	Electrical Power Dissipation @ 22°C	-	100	mW
	Optical Peak Value, once for 1 second	-	200	mW
I _{PH} (DC)	Continuous Optical Operation	-	250	µA
I _{PH} (AC)	Pulsed Signal Input 50 µs "on" / 1 ms "off"	-	1	mA

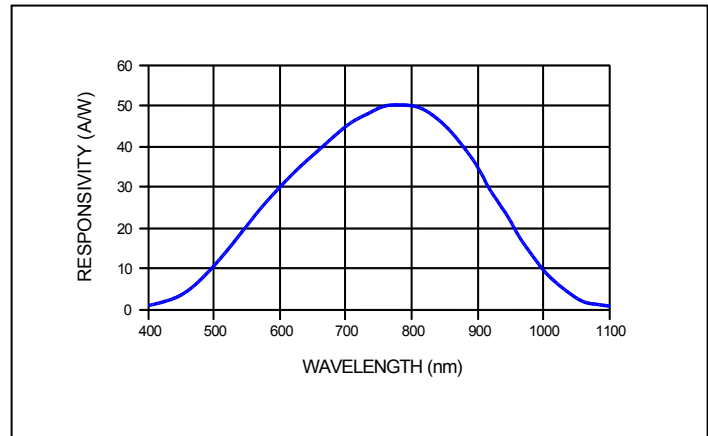
SPECTRAL RESPONSE at M = 100

ELECTRO-OPTICAL CHARACTERISTICS @ 22 °C

SYMBOL	CHARACTERISTIC	TEST CONDITIONS	MIN	TYP	MAX	UNITS
I _D	Dark Current	M = 100*	---	0.5	2.0	nA
C	Capacitance	M = 100*	---	2.2	---	pF
V _{BR}	Breakdown Voltage	I _D = 2 µA	80	200	---	V
	Temperature Coefficient of V _{BR}		0.35	0.45	0.55	V/K
	Responsivity	M = 100; = 0 V; λ = 800 nm	45	50	---	A/W
Δf _{3dB}	Bandwidth	-3dB	---	1.0	---	GHz
t _r	Rise Time		---	350	---	ps
	Optimum Gain		50	60	---	
	"Excess Noise" factor	M = 100	---	2.2	---	
	"Excess Noise" index	M = 100	---	0.2	---	
	Noise Current	M = 100	---	1.0	---	pA/Hz ^{1/2}
	Max Gain		200	---	---	
NEP	Noise Equivalent Power	M = 100; λ = 800 nm	---	2.0 X 10 ⁻¹⁴	---	W/Hz ^{1/2}

* Measurement conditions: Setup of photo current 10 nA at M = 1 and irradiated by a 680 nm, 60 nm bandwidth LED. Increase the photo current up to 1 µA, (M = 100) by internal multiplication due to an increasing bias voltage.

Disclaimer: Due to our policy of continued development, specifications are subject to change without notice.

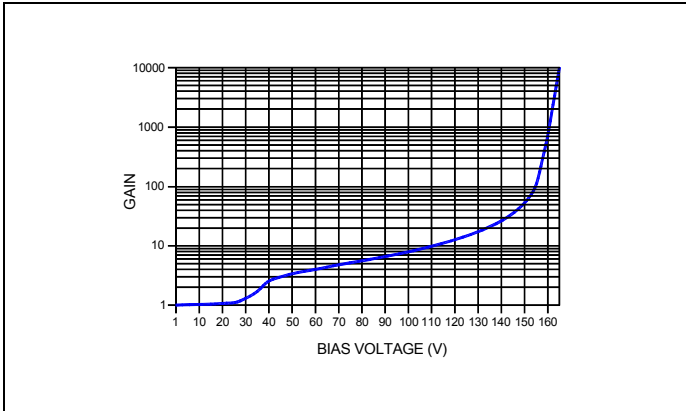
TYPICAL GAIN vs BIAS VOLTAGE



QUANTUM EFFICIENCY for M = 1

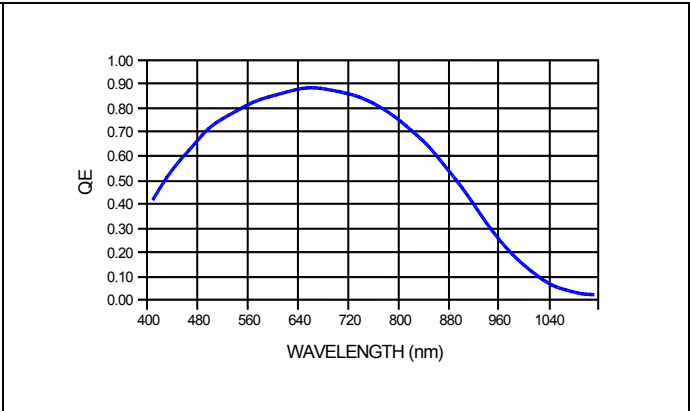

DEVICE SCHEMATIC

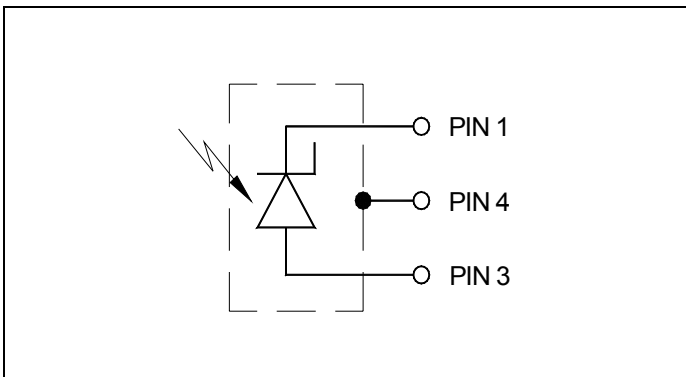

SUGGESTED CIRCUIT SCHEMATIC

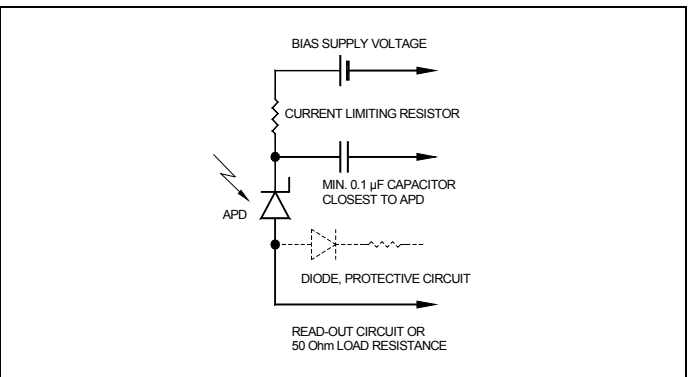

APPLICATION NOTES

- Current should be limited by a protecting resistor or current limiting IC inside the power supply.
- Use of low noise read-out IC.
- For high gain applications ($M > 50$) bias voltage should be temperature compensated.
- For low light level applications, blocking of ambient light should be used.

HANDLING PRECAUTIONS:

- Soldering temperature - 260°C for 10 seconds max. The device must be protected against solder flux vapor.
- Minimum pin length - 2 mm
- ESD protection - Standard precautionary measures are sufficient.
- Storage - Store devices in conductive foam.
- Avoid skin contact with window.
- Clean window with Ethyl alcohol if necessary.
- Do not scratch or abrade window.

USA:

Pacific Silicon Sensor, Inc.
 5700 Corsa Avenue, #105
 Westlake Village, CA 91362 USA
 Phone (818) 706-3400
 Fax (818) 889-7053
 Email: sales@pacific-sensor.com
www.pacific-sensor.com

International sales:

Silicon Sensor International AG
 Peter-Behrens-Str. 15
 D-12459 Berlin, Germany
 Phone +49 (0)30-63 99 23 10
 Fax +49 (0)30-63 99 23 33
 Email: sales@silicon-sensor.de
www.silicon-sensor.de