

4.7 mm×3.5 mm SMD Light Touch Switches

Type: **EVQP2/EVQ3P2**

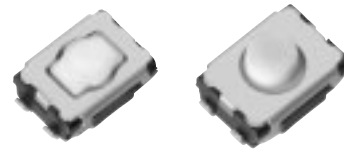

■ Features

- External dimensions : 4.7 mm×3.5 mm,
Height : Middle Push Travel 2.5 mm
Short Push Travel 2.1 mm, 2.5 mm
- High operating force and long operational life
- High mountability with J-bent (4 terminals)

www.DataSheet4U.com

■ Recommended Applications

- Keyless entry systems (automotive)
- Car audio equipment

■ Explanation of Part Numbers

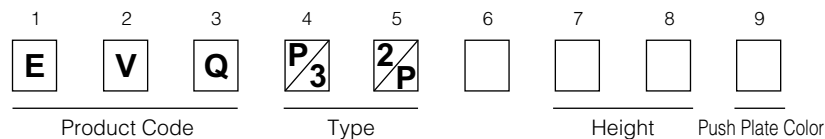

■ Specifications

Travel Type		Middle Push Travel	Short Push Travel
Type		Snap action / Push-on type SPST	
Electrical	Rating	10 μA 2 Vdc to 20 mA 15 Vdc (Resistive load)	
	Contact Resistance	100 mΩ max.	
	Insulation Resistance	100 MΩ min.	
	Dielectric Withstanding Voltage	250 Vac (1 minute)	
	Bouncing	10 ms max. (ON, OFF)	
Mechanical	Operating Force	2.5 N, 3.5 N, 5.0 N	1.0 N, 1.6 N, 2.4 N, 3.5 N
	Travel	0.70 mm±0.15 mm	0.25 mm ^{+0.05} _{-0.15} mm
Endurance	Operating Life	2.5 N: 1000000 cycles min. 3.5 N: 500000 cycles min. 5.0 N: 200000 cycles min.	1.0 N, 1.6 N: 1000000 cycles min. 2.4 N: 500000 cycles min. 3.5 N: 200000 cycles min.
Operating Temperature		-40 °C to +85 °C	
Storage Temperature		-40 °C to +85 °C (Bulk) -20 °C to +60 °C (Taping)	
Minimum Quantity/Packing Unit		4000 pcs. Embossed Taping (Reel Pack)	
Quantity/Carton		20000 pcs.	

Design and specifications are each subject to change without notice. Ask factory for the current technical specifications before purchase and/or use.
Should a safety concern arise regarding this product, please be sure to contact us immediately.

Apr. 2008

■ Dimensions in mm (not to scale)

<p>No. 1</p> <p>EVQP2 EVQ3P2</p> <p>Middle push travel With J-bent terminals (With Ground terminal)</p>	
---	--

Part Numbers	Ground Terminal	Operating Force	Height	Push Plate Color	Operating Life
EVQP2B02B	With	2.5 N	2.5 mm	Blue	1000000 cycles
EVQP2D02Q	With	3.5 N	2.5 mm	Grey	500000 cycles
EVQP2F02K	With	5.0 N	2.5 mm	Black	200000 cycles
EVQP2H02B	Without	2.5 N	2.5 mm	Blue	1000000 cycles
EVQP2K02Q	Without	3.5 N	2.5 mm	Grey	500000 cycles
EVQ3P202K	Without	5.0 N	2.5 mm	Black	200000 cycles

Design and specifications are each subject to change without notice. Ask factory for the current technical specifications before purchase and/or use.
Should a safety concern arise regarding this product, please be sure to contact us immediately.

■ Dimensions in mm (not to scale)

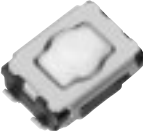
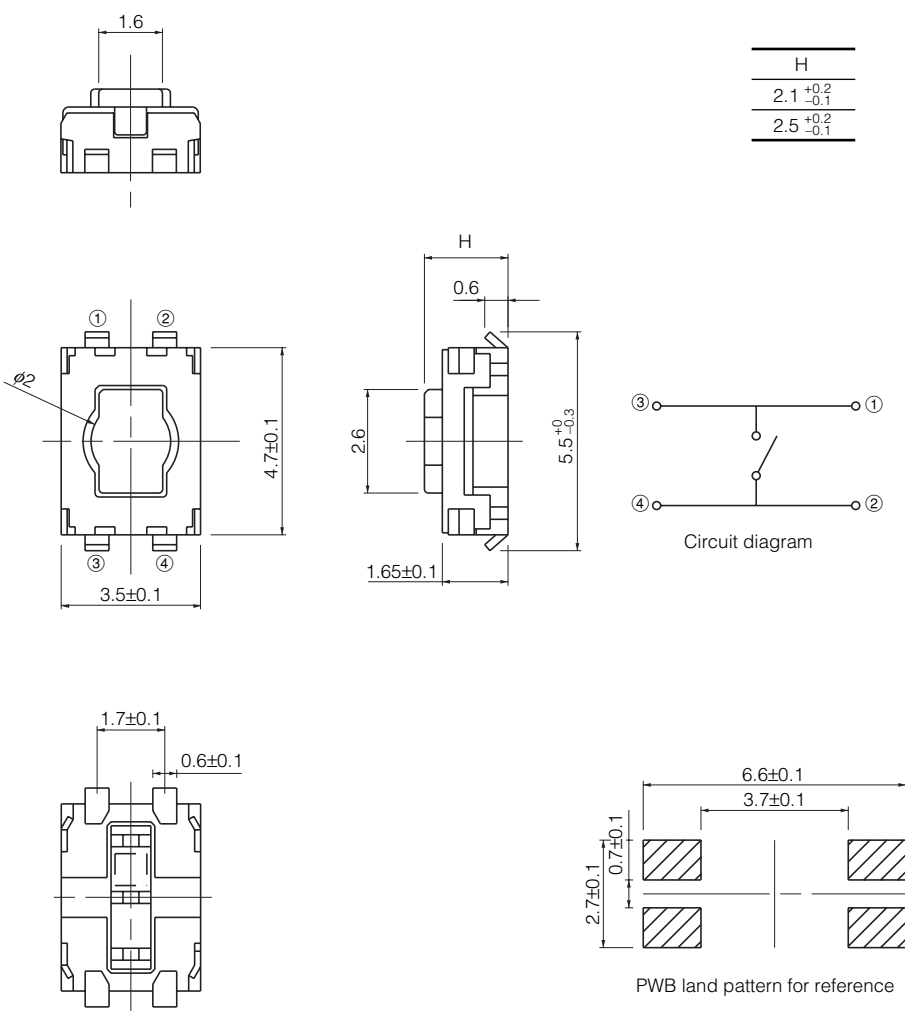
No. 2					
<p>EVQP2</p> <p>Short push travel With J-bent terminals (With Ground terminal)</p> 					
Part Numbers	Ground Terminal	Operating Force	H=Height	Push Plate Color	Operating Life
EVQP2P02M	With	1.0 N	2.1 mm	Natural	1000000 cycles
EVQP2P02W	With	1.0 N	2.5 mm	Natural	1000000 cycles
EVQP2R02M	With	1.6 N	2.1 mm	Natural	1000000 cycles
EVQP2R02W	With	1.6 N	2.5 mm	Natural	1000000 cycles
EVQP2T02M	With	2.4 N	2.1 mm	Natural	500000 cycles
EVQP2T02W	With	2.4 N	2.5 mm	Natural	500000 cycles
EVQP2V02M	With	3.5 N	2.1 mm	Natural	200000 cycles
EVQP2V02W	With	3.5 N	2.5 mm	Natural	200000 cycles
EVQP2002M	Without	1.0 N	2.1 mm	Natural	1000000 cycles
EVQP2002W	Without	1.0 N	2.5 mm	Natural	1000000 cycles
EVQP2202M	Without	1.6 N	2.1 mm	Natural	1000000 cycles
EVQP2202W	Without	1.6 N	2.5 mm	Natural	1000000 cycles
EVQP2402M	Without	2.4 N	2.1 mm	Natural	500000 cycles
EVQP2402W	Without	2.4 N	2.5 mm	Natural	500000 cycles
EVQP2602M	Without	3.5 N	2.1 mm	Natural	200000 cycles
EVQP2602W	Without	3.5 N	2.5 mm	Natural	200000 cycles

Design and specifications are each subject to change without notice. Ask factory for the current technical specifications before purchase and/or use. Should a safety concern arise regarding this product, please be sure to contact us immediately.

Recommended Reflow Soldering Conditions

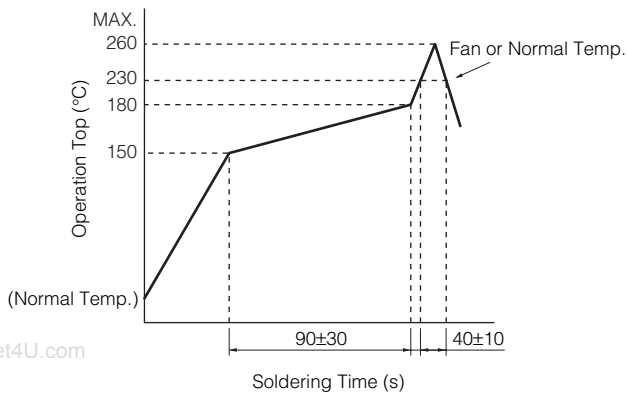

Embossed Carrier Taping

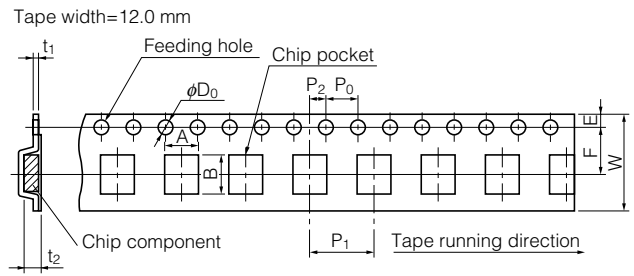

Unit: mm

Part No.	Height	A	B	W	F	E	P ₁	P ₂	P ₀	D ₀ Dia.	t ₁	t ₂
EVQP2	2.1	6.0±0.2	4.7±0.2	12.0±0.3	5.5±0.1	1.75±0.10	8.0±0.1	2.0±0.1	4.0±0.1	1.5 ^{+0.1} ₋₀	0.3±0.1	2.7±0.2
EVQ3P2	2.5											

Standard Reel Dimensions in mm (not to scale)

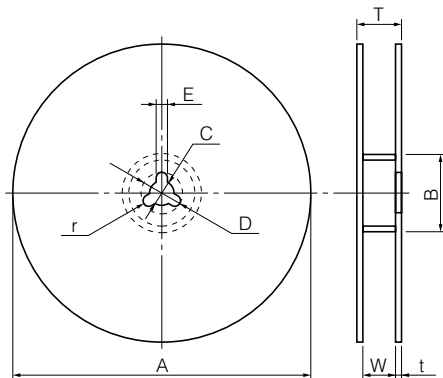

Item	A	B	C	D	E
Rate (mm)	φ370.0±2.0	φ50.0 min.	φ13.0±0.5	φ21.0±1.0	2.0±0.5

Item	W	T	t	r
Rate (mm)	14.0±1.5	—	1.0 to 3.0	1.0±0.5

Recommended Shape of Test Pole

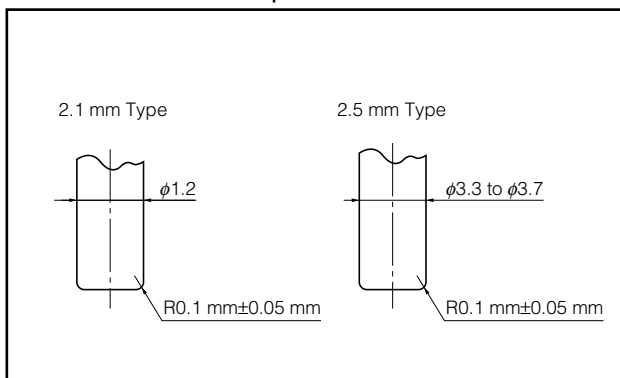

Recommended Operating Conditions

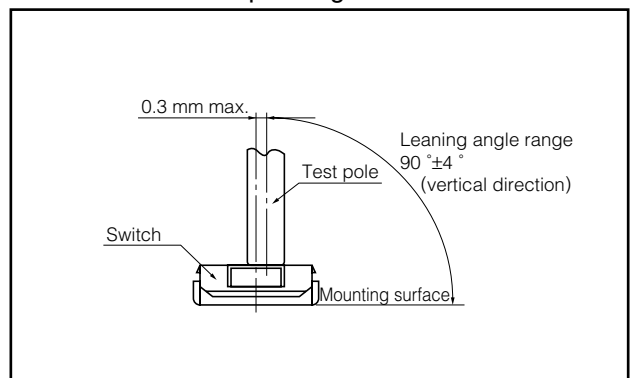

Design and specifications are each subject to change without notice. Ask factory for the current technical specifications before purchase and/or use. Should a safety concern arise regarding this product, please be sure to contact us immediately.